

## SYSTEM OVERVIEW

**Description:** The Vertiv™ NetSure™ 211NGFB DC Power System is an integrated power system containing rectifiers, intelligent control, metering, monitoring, and distribution. This power system consists of the following mounted in a 1RU or 2RU high by 19" or 23" wide shelf.

- **500W or 1000W Rectifier Modules**

The system contains rectifier modules, which provide load power, battery float current, and battery recharge current during normal operating conditions. Refer to the rectifier instructions (UM1R481000) for more information.

The 1RU high by 19" wide shelf accommodates two (2) 500W or 1000W rectifier modules.

The 1RU high by 23" wide shelf accommodates three (3) 500W or 1000W rectifier modules.

The 2RU high by 19" wide shelf accommodates four (4) 500W or 1000W rectifier modules.

The 2RU high by 23" wide shelf accommodates six (6) 500W or 1000W rectifier modules.

- **NCU (NetSure™ Control Unit) Controller**

The controller provides power system control (including optional Low Voltage Battery Disconnect (LVBD) and Low Voltage Load Disconnect (LVLD) control), rectifier control (including a charge control function), metering functions, monitoring functions, local/remote alarm functions, and connections for binary inputs and programmable relay outputs. The controller also supports rectifier temperature compensation if the system is equipped with a temperature probe(s). Temperature probe(s) may also be designated to monitor ambient temperature and/or battery temperature. The controller also provides data acquisition, system alarm management, and advanced battery and energy management. The controller contains a color TFT display and keypad for local access. The controller provides an Ethernet port and comes with comprehensive webpages for remote access. The controller has SNMP V3 capability for remote system management. The controller supports software upgrade via its USB port. Refer to the NCU controller instructions (UM1M830BNA) for more information.

- **Distribution Unit**

Various distribution unit options are available, as described in this document. The distribution unit can be equipped with an optional Low Voltage Battery Disconnect (LVBD) or Low Voltage Load Disconnect (LVLD) contactor.

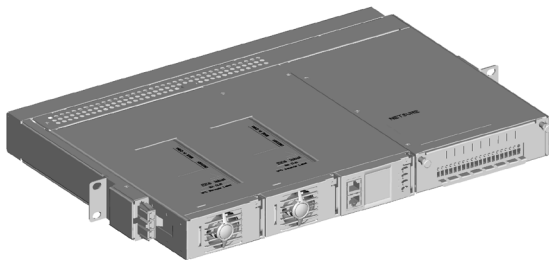

List 1 (List 2 similar)

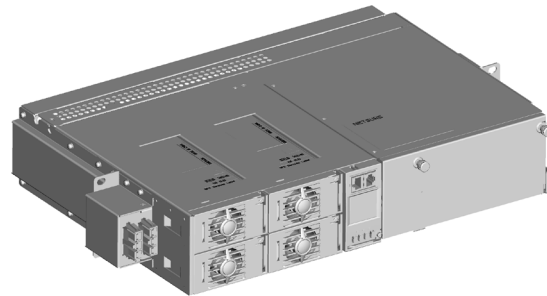

List 5 (List 6 similar)

**General Specifications**

See detailed specifications starting on page 80.

Family:	Vertiv™ NetSure™
Spec. No.:	582136600
Model:	211NGFB
Input Voltage	Nominal 120/208/240 volts AC, single phase, 3-wire, 50/60 Hz, with an operating range of 100 to 250 volts. Acceptable input frequency range is 45 to 65 Hz.
Output Voltage:	-48 Volts DC
Output Capacity:	
Rectifier Module:	500W @ Vout >48Vdc (10.5A @ -48Vdc) or 1000W @ Vout >48Vdc (20.9A @ -48Vdc)
System:	See the following table.

System DC Output Capability								
Spec. No.	208/240VAC Input				120VAC Input			
	+40°C (+104°F)		+65°C (+149°F)		+40°C (+104°F)		+65°C (+149°F)	
	500W Rect.	1000W Rect.	500W Rect.	1000W Rect.	500W Rect.	1000W Rect.	500W Rect.	1000W Rect.
<b>58213660001</b>	20.8A	41.6A	12.6A	25A	20.8A	27.4A	12.6A	16.4A
<b>58213660002</b>	31.2A	62.4A	18.9A	37.5A	31.2A	41.1A	18.9A	24.6A
<b>58213660005</b>	41.6A	83.2A	25.2A	50A	41.6A	54.8A	25.2A	32.8A
<b>58213660006</b>	62.4A	124.8A	37.8A	75A	62.4A	82.2A	37.8A	49.2A

Agency Approval:	UL 60950 Recognized, CAN/CSA 22.2
Framework Type:	Relay Rack Mounted
Mounting Width:	19" or 23", nominal
Mounting Depth:	12"
Mounting Height:	1.75" (1RU) or 3.5" (2RU)
Access:	Front for Installation, Operation, and Maintenance
Control:	Microprocessor
Color:	Front Panels are Gray; Shelf is Galvaneal
Environment:	-40°C (-40°F) to +65°C (+149°F), with deratings (see SPECIFICATIONS section starting on page 80)

**TABLE OF CONTENTS**

SYSTEM OVERVIEW ..... 1

MAIN COMPONENTS ILLUSTRATIONS..... 6

    58213660001..... 6

    58213660002 ..... 6

    58213660001 with P/N 555260 ..... 7

    58213660005 ..... 8

    58213660006 ..... 8

    Other ..... 9

LIST DESCRIPTIONS ..... 11

    List Numbers..... 11

        List 1: 1RU High by 19" Wide Shelf..... 11

        List 2: 1RU High by 23" Wide Shelf ..... 12

        List 5: 2RU High by 19" Wide Shelf ..... 13

        List 6: 2RU High by 23" Wide Shelf ..... 14

        List 60: Five (5) Load Lead Assemblies (P/N 535206) for 10A GMT Fuse Positions ..... 15

        List 61: Eight (8) Load Lead Assemblies (P/N 535206) for 10A GMT Fuse Positions..... 15

        List 62: Five (5) Load Lead Assemblies (P/N 540988) for 15A GMT Fuse Positions..... 15

        List 65: Shelf Side Battery Cables, P/N 540814 ..... 15

        List 66: Battery Side Battery Cables, P/N 540954..... 16

        List 67: Battery Cable, P/N 545709 ..... 16

        List 71: Optional External Battery Cable Assembly with Anderson Connector for (1) Battery String, P/N 545493 ..... 16

        List 72: Optional External Battery Cable Assembly with Anderson Connector for (2) Battery Strings, P/N 535124 ..... 17

        List 73: Optional External Battery Cable Assembly with Anderson Connector for (1) Battery String, P/N 555050 ..... 17

        List 89: Relay Rack Earthquake Anchor Kit, P/N P0987167 ..... 17

        List 90: Optional Temperature Probe, P/N 04118246 (shelf side half) and P/N 04118247 (probe side half, 9 ft. long)..... 18

        List 91: Optional Temperature Probe, P/N 04118246 (shelf side half) and P/N 04116740 (probe side half, 30 ft. long) ..... 18

        List 93: Battery Tray for 23" Relay Rack ..... 19

        List 94: Battery Tray for 19" Relay Rack ..... 23

    Distribution Unit..... 27

        List BF: Distribution Unit with GMT Fuse Load Distribution Positions and with Low Voltage Battery Disconnect (LVBD)..... 27

        List NF: Distribution Unit with GMT Fuse Load Distribution Positions and w/out Low Voltage Disconnect ..... 28

        List BC: Distribution Unit with GMT Fuse Load Distribution Positions, Circuit Breaker Load Distribution Positions, and with Low Voltage Battery Disconnect (LVBD)..... 29

        List NC: Distribution Unit with GMT Fuse Load Distribution Positions, Circuit Breaker Load Distribution Positions, and w/out Low Voltage Disconnect..... 30

        List BA: Distribution Unit with GMT Fuse Load Distribution Positions, Circuit Breaker Load Distribution Positions, Circuit Breaker Battery Disconnect Positions, and with Low Voltage Battery Disconnect (LVBD)..... 31

        List NA: Distribution Unit with GMT Fuse Load Distribution Positions, Circuit Breaker Load Distribution Positions, Circuit Breaker Battery Disconnect Positions, and w/out Low Voltage Disconnect..... 32

        List BG: Distribution Unit with GMT Fuse Load Distribution Positions and with Low Voltage Battery Disconnect (LVBD)..... 33

        List NG: Distribution Unit with GMT Fuse Load Distribution Positions and w/out Low Voltage Disconnect..... 34

        List KG: Distribution Panel with (20) GMT Fuse Load Distribution Positions..... 35

ACCESSORY DESCRIPTIONS ..... 36

    Relay Racks ..... 36

    Rectifier ..... 37

        Rectifier Module (500W), P/N 1R48500..... 37

        Rectifier Module (1000W), P/N 1R481000 ..... 37

    Controller ..... 38

        NCU (NetSure™ Control Unit), P/N 1M830BNA ..... 38

    Optional Temperature Probes..... 38

    Mounting and Adapter Kits..... 40

        Optional Wall Mount Bracket Kit for Lists 1 and 2, P/N 541285 ..... 40

        Optional Wall Mount Bracket Kit for Lists 1, 2, 5 and 6, P/N 553203 ..... 40

Optional 19" to 23" 1RU Rack Adapter Kit, P/N 540993.....	40
Optional 19" to 23" 2RU Rack Adapter Kit, P/N 545728.....	40
Optional 19" Rear Cover Kit, P/N 555260.....	41
Rear Battery Cable Exit Kit P/N 547645.....	41
Distribution Devices.....	<b>42</b>
GMT Load Distribution Fuses.....	42
Bullet Nose-Type Circuit Breakers.....	43
Optional Bullet Nose 6-Position GMT Fuse Module, P/N 545332.....	44
Optional Bulk Output Busbar, P/N 535015.....	44
AC Input Cables and Line Cords.....	<b>45</b>
AC Input Cable Assembly, P/N 535232.....	45
AC Input Line Cord, 208/240VAC, P/N 540946.....	45
AC Input Line Cord, 208/240VAC, P/N 559301.....	45
AC Input Line Cord, 208/240VAC, P/N 545616.....	46
AC Input Line Cord, 208/240VAC, P/N 559842.....	46
AC Input Line Cord, 208/240VAC, P/N 559302.....	46
AC Input Line Cord, 120VAC, P/N 545252.....	47
AC Input Line Cord, 120VAC, P/N 545478.....	47
AC Input Line Cord, 120VAC, P/N 545479.....	47
AC Input Line Cord, 208/240VAC, P/N 545480.....	48
AC Input Line Cord, 208/240VAC, P/N 545482.....	48
AC Input Line Cord, 120VAC, P/N 545481.....	48
AC Input Line Cord, 208/240VAC, P/N 545553.....	49
AC Input Line Cord, 120VAC, P/N 547525.....	49
AC Input Line Cord, 120VAC, P/N 548457.....	49
AC Input Line Cord, 120/208/240VAC, P/N 548196.....	50
AC Input Line Cord, 120VAC, P/N 10015356.....	50
AC Input Line Cord, 120VAC, P/N 10015358.....	51
Special Application Digital Input Cable Kit, P/N 554935.....	<b>51</b>
Vertiv™ NetSure™ 211BC Battery Cabinet (Spec. No. 541434).....	<b>52</b>
Vertiv™ NetSure™ 211BC Battery Cabinet (Spec. No. 545534).....	<b>53</b>
Vertiv™ NetSure™ 211BC Battery Cabinet (Spec. No. 545506).....	<b>54</b>
SM TEMP Temperature Concentrator (P/N 547490).....	<b>55</b>
SM Module RS-485 Interface Cable P/N 547674.....	<b>55</b>
PCU Blank Filler Panel, P/N PSK4820R-1.....	<b>55</b>
Anderson Battery Connector.....	<b>56</b>
Digital Input and Relay Output Cables.....	<b>57</b>
User Replaceable Components.....	<b>57</b>
Wiring Notes.....	<b>58</b>
Shelf Frame Grounding Stud.....	58
AC Input Branch Circuit Protection and Wiring.....	58
External Alarm and Monitoring Wiring.....	58
Load Distribution Wiring (GMT Fuses) (Lists BG and NG only).....	59
Load Distribution Wiring (GMT Fuses) (Lists BF and NF only).....	59
Load Distribution Wiring (GMT Fuses) (Lists BC, NC, BA, and NA).....	59
Load Distribution Wiring (Optional Bullet-Nose-Type 6-Position GMT Fuse Module).....	60
Load Distribution Wiring (Circuit Breakers) (Lists BC, NC, BA, and NA).....	60
Load Distribution Wiring (GMT Fuses) (List KG).....	62
CO Ground Wiring (Lists BF, NF, BC, NC, BA, and NA).....	62
Input Battery Wiring (List BG and NG).....	62
Input Battery Wiring (to Battery Disconnect Circuit Breakers) (Lists BA and NA).....	62
Input Battery Wiring (to Battery Busbars) (Lists BF, NF, BC, and NC).....	63
Wiring Illustrations.....	<b>64</b>
Shelf Frame Grounding Stud.....	64
AC Input Wiring (Lists 1 and 2).....	65
AC Input Wiring (Lists 5 and 6).....	66
External Alarm and Monitoring Wiring (Lists 1 and 2).....	67
External Alarm and Monitoring Wiring (Lists 5 and 6).....	68
Load Distribution Wiring (GMT Fuses) (Lists BG and NG installed in a List 1 or 2, List 1 shown).....	71
Load Distribution Wiring (GMT Fuses) (Lists BF and NF installed in a List 5 or 6, List 5 shown).....	72

Load Distribution Wiring (GMT Fuses) (Lists BC, NC, BA, and NA installed in a List 5 or 6, List 5 shown).....	73
Load Distribution Wiring (Optional Bullet Nose 6-Position GMT Fuse Module).....	74
Load Distribution Wiring (Circuit Breakers) and CO Ground Wiring (Lists BC, and NC installed in a List 5 or 6, List 5 shown) .....	75
Load Distribution Wiring (Circuit Breakers), Input Battery Wiring (Circuit Breakers), and CO Ground Wiring (Lists BA and NA installed in a List 5 or 6, List 5 shown) .....	76
Load Distribution Wiring (GMT Fuses) (List KG).....	77
Input Battery Wiring (Lists BG and NG installed in a List 1 or 2, List 1 shown).....	78
Input Battery Wiring (Lists BF, NF, BC, and NC installed in a List 1 or 5, List 5 shown) and CO Ground Wiring (Lists BF and NF installed in a List 1 or 5, List 5 shown).....	79
<b>SPECIFICATIONS.....</b>	<b>80</b>
1. System.....	80
1.1 Environmental Ratings.....	80
1.2 Compliance Information.....	80
1.3 Standard Features.....	81
2. Rectifier .....	82
3. Controller.....	82
<b>MECHANICAL SPECIFICATIONS .....</b>	<b>83</b>
Overall Dimensions – List 1 .....	83
Additional Dimensions – List 1 with Wall Mounting Kit (P/N 541285) .....	84
Additional Dimensions – List 1 with Optional 19” Rear Cover Kit, P/N 555260 .....	85
Overall Dimensions – List 2.....	86
Additional Dimensions – List 2 with Wall Mounting Kit (P/N 541285).....	87
Overall Dimensions – List 5.....	88
Overall Dimensions – List 6 .....	89
Additional Dimensions – Lists 1, 2, 5 and 6 with Wall Mounting Kit (P/N 553203).....	90
Overall Dimensions – List KG .....	91
Overall Dimensions – 19” Battery Tray .....	92
Overall Dimensions – 23” Battery Tray .....	93
<b>BATTERY MANUFACTURER INFORMATION.....</b>	<b>94</b>
<b>RELATED DOCUMENTATION .....</b>	<b>94</b>

**MAIN COMPONENTS ILLUSTRATIONS**

**5821366001**

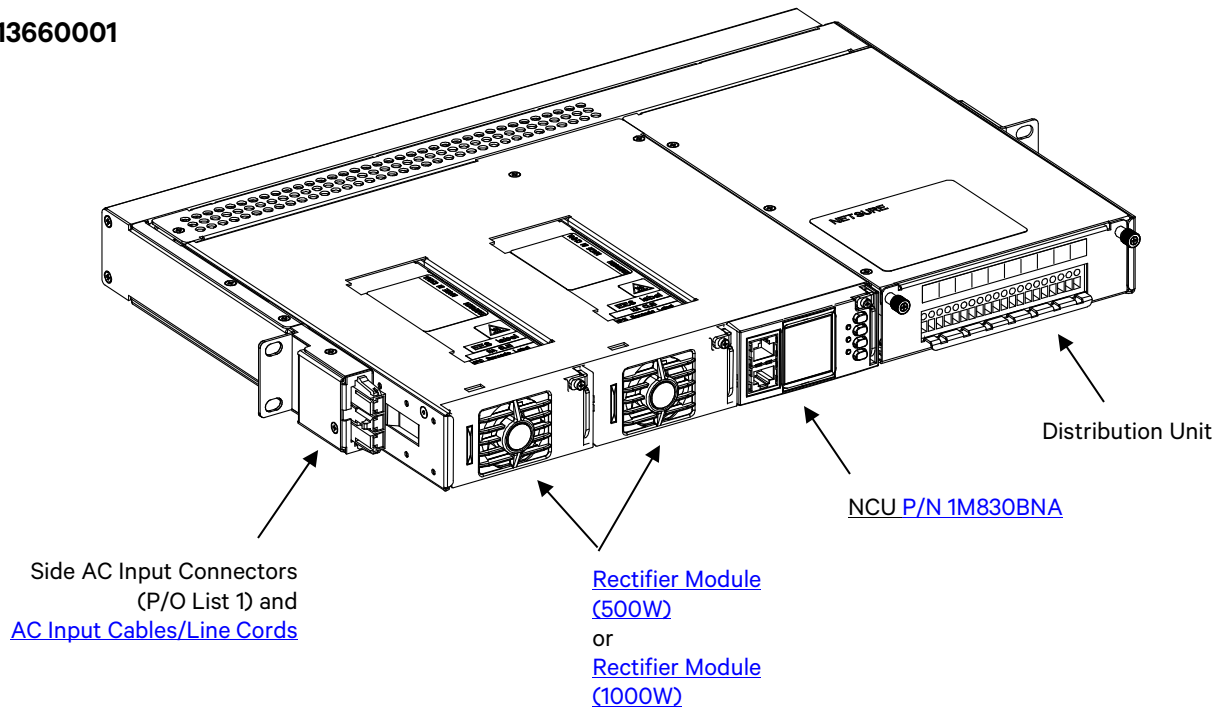

**5821366002**

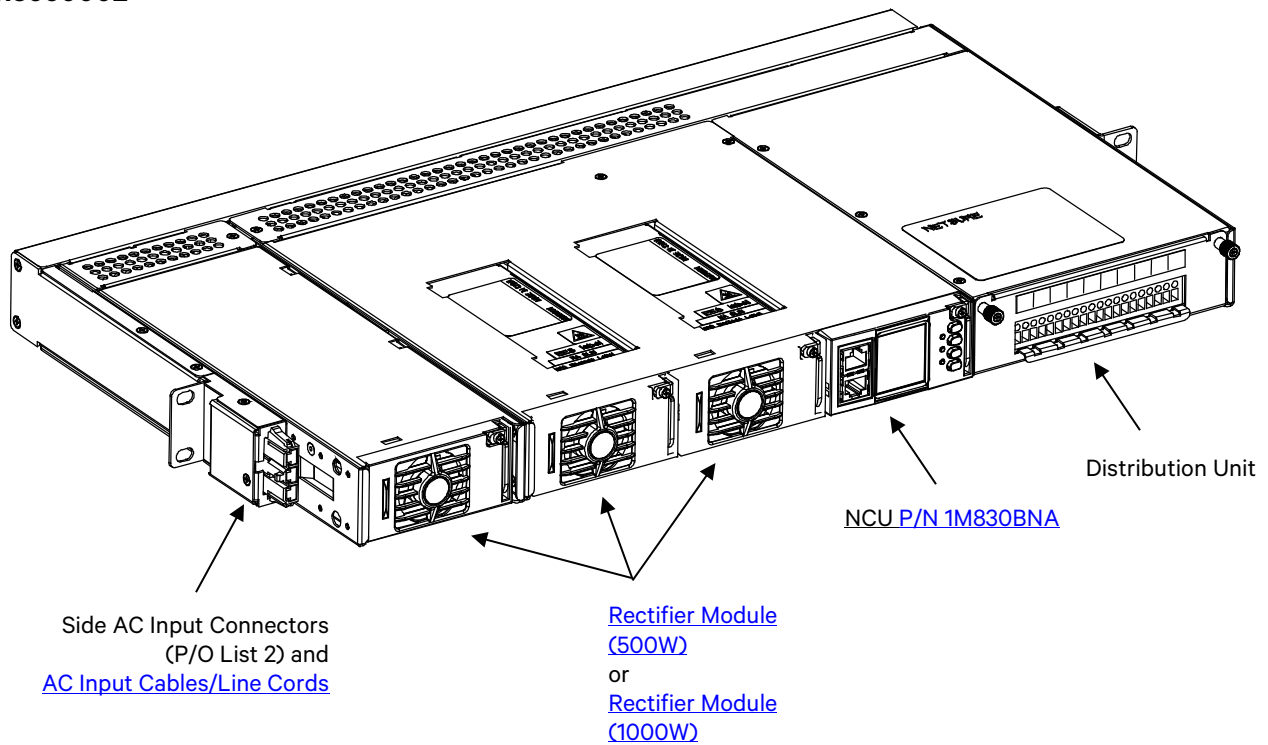

**5821366001 with P/N 555260**

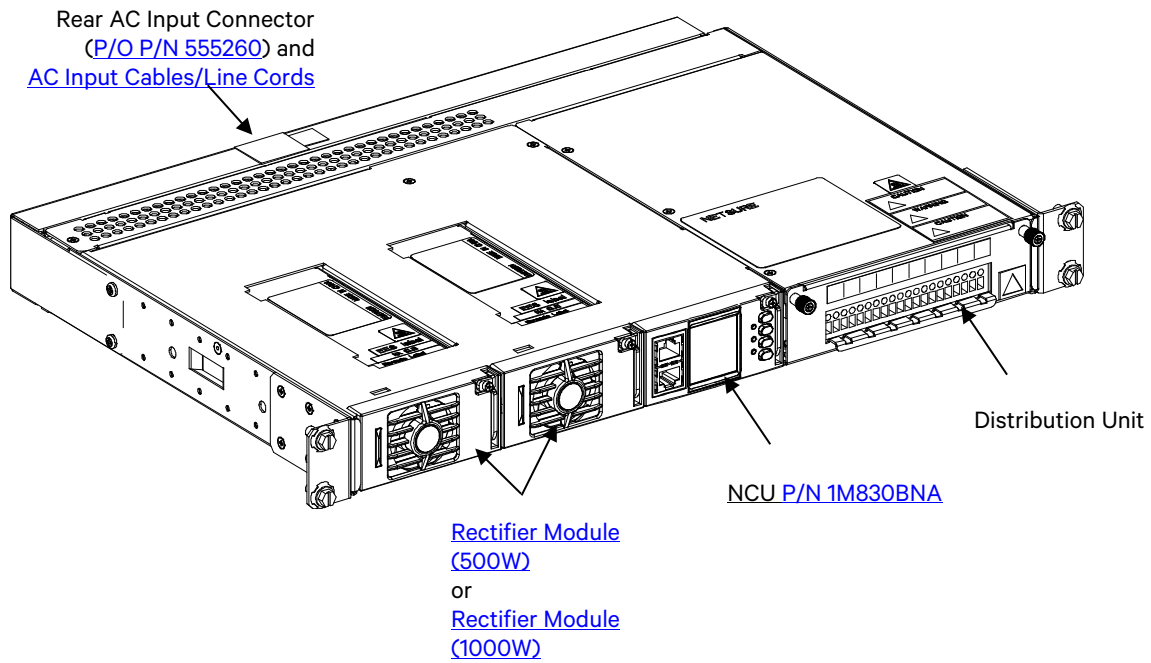

5821366005

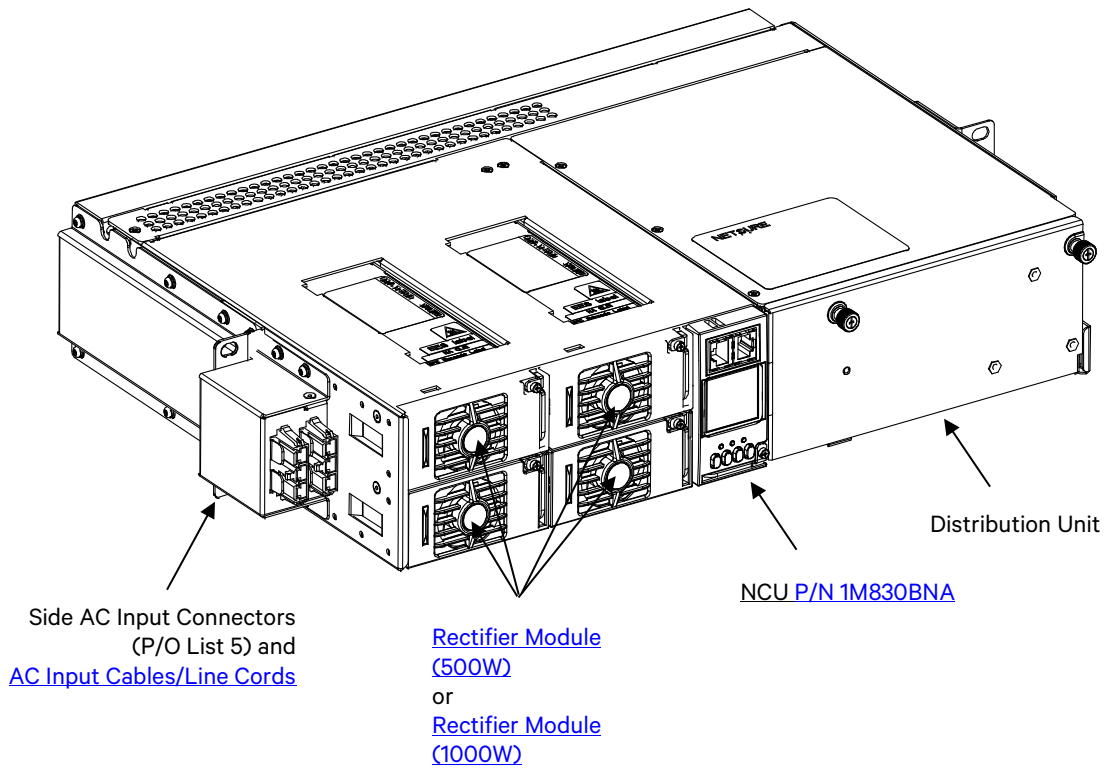

5821366006

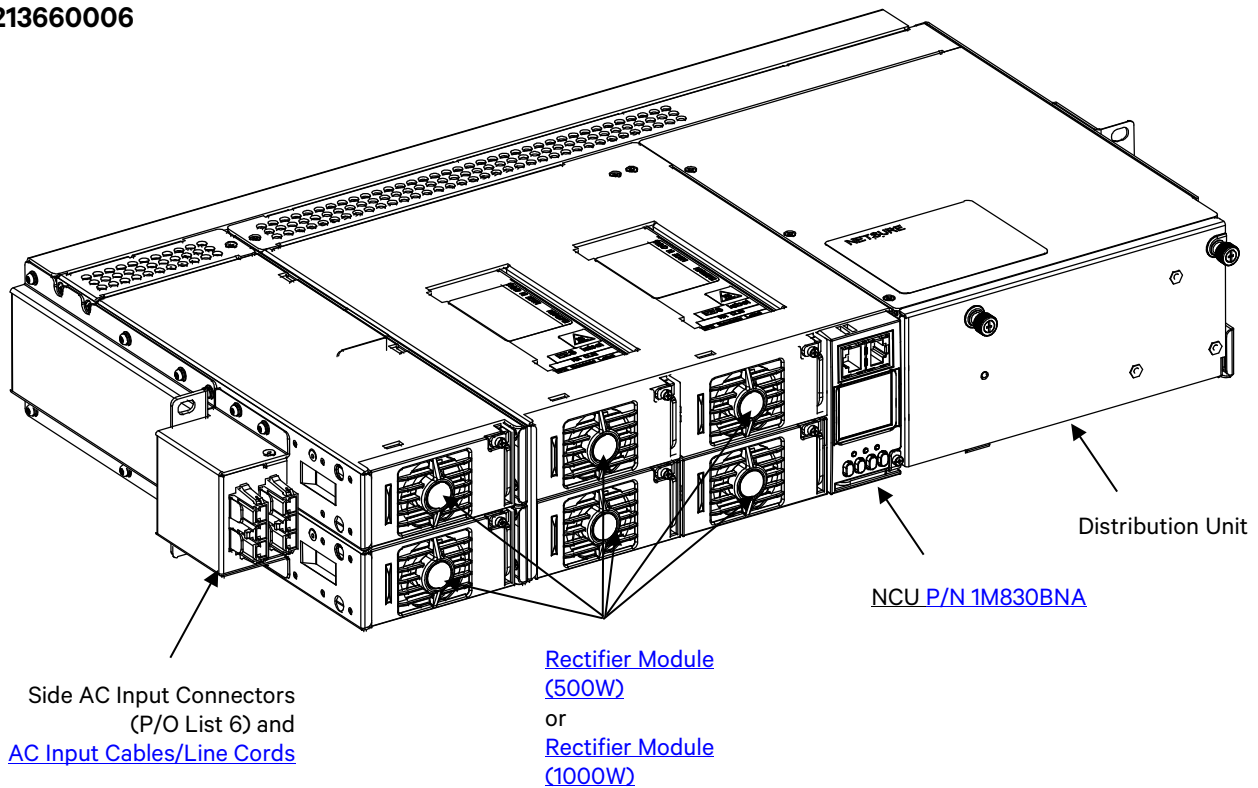



**Other**

**DISTRIBUTION UNIT (Lists 1 and 2)**

[List BG:](#) (10) GMT Fuse Load Positions  
Low Voltage Battery Disconnect (LVBD)  
(1) Set Battery Cables

[List NG:](#) (10) GMT Fuse Load Positions  
NO Low Voltage Disconnect  
(1) Set Battery Cables

**DISTRIBUTION UNIT (Lists 5 and 6)**

[List BF:](#) (13) GMT Fuse Load Positions  
Low Voltage Battery Disconnect (LVBD)  
(3) Battery Landing Points

[List NF:](#) (13) GMT Fuse Load Positions  
NO Low Voltage Disconnect  
(3) Battery Landing Points

[List BC:](#) (5) GMT Fuse Load Positions  
(4) Bullet-Nose Circuit Breaker Load Positions  
Low Voltage Battery Disconnect (LVBD)  
(3) Battery Landing Points

[List NC:](#) (5) GMT Fuse Load Positions  
(4) Bullet-Nose Circuit Breaker Load Positions  
NO Low Voltage Disconnect  
(3) Battery Landing Points

[List BA:](#) (5) GMT Fuse Load Positions  
(2) Bullet-Nose Circuit Breaker Load Positions  
(2) Bullet-Nose Circuit Breaker Battery Disconnect Positions  
Low Voltage Battery Disconnect (LVBD)

[List NA:](#) (5) GMT Fuse Load Positions  
(2) Bullet-Nose Circuit Breaker Load Positions  
(2) Bullet-Nose Circuit Breaker Battery Disconnect Positions  
NO Low Voltage Disconnect

**Other List Options**

- [List 60:](#) Five (5) Load Lead Assemblies for 10A GMT Fuse Positions  
(for use w/ Lists BC, NC, BA, and NA)
- [List 61:](#) Eight (8) Load Lead Assemblies for 10A GMT Fuse Positions  
(for use w/ Lists BF and NF)
- [List 62:](#) Five (5) Load Lead Assemblies for 15A GMT Fuse Positions  
(for use w/ Lists BF and NF)
- [List 65:](#) Shelf Side Battery Cables  
(for use w/ Lists BF, NF, BC, and NC)
- [List 66:](#) Battery Side Battery Cables  
(for use w/ Lists BF, NF, BC, and NC)
- [List 67:](#) Battery Side Battery Cables  
(For use with Lists BC, NC, BF, and NF)
- [List 71:](#) Optional External Battery Cables (8 AWG) with Anderson Connector  
for (1) Battery String (for use w/ Lists BG and NG)
- [List 72:](#) Optional External Battery Cables with Anderson Connector  
for (2) Battery Strings (for use w/ Lists BG and NG)
- [List 73:](#) Optional External Battery Cables (6 AWG) with Anderson Connector  
for (1) Battery String (for use w/ Lists BG and NG)
- [List 89:](#) Relay Rack Earthquake Anchor Kit
- [List 90:](#) Temperature Probe (12 ft. total)
- [List 91:](#) Temperature Probe (33 ft. total)
- [List 93:](#) Battery Tray (23")
- [List 94:](#) Battery Tray (19")
- [List KG:](#) GMT Fuse Load Distribution Panel

## LIST DESCRIPTIONS

### List Numbers

#### List 1: 1RU High by 19" Wide Shelf

##### Features

- ◆ Consists of a 1RU high by 19" wide shelf.
- ◆ Two (2) 8 AWG 48" long battery cables are factory connected inside the shelf. These cables are terminated at the customer end in a red SB50 Anderson battery connector. A mating Anderson battery connector is provided [Housing: Vertiv P/N 138922, Anderson Power Products P/N 992G1. Contacts (two provided): Vertiv P/N 247109602, Anderson Power Products P/N 5952].
- ◆ Mounted to the side of the shelf is an AC input housing with plug-in connector for a single AC input feed.
- ◆ The "Digital Input and Relay Outputs Cable" P/N 545494 (shelf side) is factory connected inside the shelf. A mating half is available.
- ◆ The shelf houses up to two (2) rectifier modules, one (1) controller, and one (1) distribution unit.

##### Restrictions

Each List 1 shelf holds up to two (2) rectifier modules.

##### Ordering Notes

- 1) Order List 1 as required.  
Also order the following as required.
- 2) Order one (1) NCU (P/N [1M830BNA](#)) controller per shelf. Also specify the appropriate configuration file for your site.
- 3) Order up to two (2) rectifier modules per shelf: P/N [1R48500](#) (500W) or P/N [1R481000](#) (1000W).
- 4) Order [AC Input Cables or Line Cords](#) as required. Note that each List 1 shelf requires one (1) AC input cable or line cord.
- 5) Order one (1) distribution unit (List [BG](#) or [NG](#)) per shelf.
- 6) Order optional external battery cables with Anderson connector for one (1) to two (2) battery strings per List [71](#), [72](#) or [73](#).
- 7) Order relay rack anchor kit(s) ([List 89](#)) as required.
- 8) Order up to two (2) temperature probes ([List 90](#) or [91](#)) as required. One probe is used with the battery charge temperature compensation feature, the other to monitor ambient temperature. See "Optional Temperature Probes" on page 38 for temperature probe options with a mounting tab.
- 9) Order battery trays ([List 94](#)) as required.
- 10) Order [Relay Racks](#) per ACCESSORY DESCRIPTIONS section.
- 11) Order [Distribution Devices](#) per ACCESSORY DESCRIPTIONS section.
- 12) Order [External Battery Disconnect Unit](#) per ACCESSORY DESCRIPTIONS section.
- 13) Order [Battery Cabinet](#) per ACCESSORY DESCRIPTIONS section.
- 14) Order [mating digital input/relay output cables](#) per ACCESSORY DESCRIPTIONS section.
- 15) Order [spare Anderson Battery Connector](#) per ACCESSORY DESCRIPTIONS section.
- 16) Order [Special Application Digital Input Cable Kit](#) per ACCESSORY DESCRIPTIONS section.

**List 2: 1RU High by 23" Wide Shelf**

**Features**

- ◆ Consists of a 1RU high by 23" wide shelf.
- ◆ Two (2) 8 AWG 48" long battery cables are factory connected inside the shelf. These cables are terminated at the customer end in a red SB50 Anderson battery connector. A mating Anderson battery connector is provided [Housing: Vertiv P/N 138922, Anderson Power Products P/N 992G1. Contacts (two provided): Vertiv P/N 247109602, Anderson Power Products P/N 5952].
- ◆ Mounted to the side of the shelf is an AC input housing with plug-in connector for a single AC input feed.
- ◆ The "Digital Input and Relay Outputs Cable" P/N 545494 (shelf side) is factory connected inside the shelf. A mating half is available.
- ◆ The shelf houses up to three (3) rectifier modules, one (1) controller, and one (1) distribution unit.

**Restrictions**

Each List 2 shelf holds up to three (3) rectifier modules.

**Ordering Notes**

- 1) Order List 2 as required.  
Also order the following as required.
- 2) Order one (1) NCU (P/N [1M830BNA](#)) controller per shelf. Also specify the appropriate configuration file for your site.
- 3) Order up to three (3) rectifier modules per shelf: P/N [1R48500](#) (500W) or P/N [1R481000](#) (1000W).
- 4) Order [AC Input Cables or Line Cords](#) as required. Note that each List 2 shelf requires one (1) AC input cable or line cord.
- 5) Order one (1) distribution unit (List [BG](#) or [NG](#)) per shelf.
- 6) Order optional external battery cables with Anderson connector for one (1) to two (2) battery strings per List [71](#), [72](#) or [73](#).
- 7) Order relay rack anchor kit(s) ([List 89](#)) as required.
- 8) Order up to two (2) temperature probes ([List 90](#) or [91](#)) as required. One probe is used with the battery charge temperature compensation feature, the other to monitor ambient temperature. See "Optional Temperature Probes" on page 38 for temperature probe options with a mounting tab.
- 9) Order battery trays ([List 93](#)) as required.
- 10) Order [Relay Racks](#) per ACCESSORY DESCRIPTIONS section.
- 11) Order [Distribution Devices](#) per ACCESSORY DESCRIPTIONS section.
- 12) Order [External Battery Disconnect Unit](#) per ACCESSORY DESCRIPTIONS section.
- 13) Order [Battery Cabinet](#) per ACCESSORY DESCRIPTIONS section.
- 14) Order [mating digital input/relay output cables](#) per ACCESSORY DESCRIPTIONS section.
- 15) Order [spare Anderson Battery Connector](#) per ACCESSORY DESCRIPTIONS section.
- 16) Order [Special Application Digital Input Cable Kit](#) per ACCESSORY DESCRIPTIONS section.

**List 5: 2RU High by 19" Wide Shelf**

**Features**

- ◆ Consists of a 2RU high by 19" wide shelf.
- ◆ Mounted to the side of the shelf is an AC input housing with plug-in connectors for two (2) AC input feeds.
- ◆ Includes the customer interface board that provides additional relay outputs and digital inputs.
- ◆ The "Relay Outputs Cable" P/N 541308 (shelf side) is factory connected inside the shelf. A mating half is available. A "Digital Input Cable" (shelf side and customer side) is also available.
- ◆ The shelf houses up to four (4) rectifier modules, one (1) controller, and one (1) distribution unit.

**Restrictions**

Each List 5 shelf holds up to four (4) rectifier modules.

**Ordering Notes**

- 1) Order List 5 as required.  
Also order the following as required.
- 2) Order one (1) NCU (P/N [1M830BNA](#)) controller per shelf. Also specify the appropriate configuration file for your site.
- 3) Order up to four (4) rectifier modules per shelf: P/N [1R48500](#) (500W) or P/N [1R481000](#) (1000W).
- 4) Order [AC Input Cables or Line Cords](#) as required. Note that each List 5 shelf requires two (2) AC input cables or line cords.
- 5) Order one (1) distribution unit (List [BF](#), [NF](#), [BC](#), [NC](#), [BA](#), or [NA](#)) per shelf.
- 6) Order one (1) [List 60](#) for each List BC, NC, BA, or NA ordered.  
Each List 60 provides five (5) load lead assemblies for 10A GMT fuse positions.  
Order one (1) [List 61](#) for each List BF or NF ordered.  
Each List 61 provides eight (8) load lead assemblies for 10A GMT fuse positions.  
Order one (1) [List 62](#) for each List BF or NF ordered.  
Each List 62 provides five (5) load lead assemblies for 15A GMT fuse positions.
- 7) Order one (1) [List KG](#) distribution fuse panel per shelf, as required.
- 8) Order three (3) sets of shelf side and three (3) sets of battery side battery cables ([List 65](#) and [List 66](#)) for each List BC, NC, BF, or NF ordered.
- 9) Order up to three (3) [List 67](#) for each List BC, NC, BF, and NF ordered.
- 10) Order relay rack anchor kit(s) ([List 89](#)) as required.
- 11) Order up to two (2) temperature probes ([List 90](#) or [91](#)) as required. One probe is used with the battery charge temperature compensation feature, the other to monitor ambient temperature. See "Optional Temperature Probes" on page 38 for temperature probe options with a mounting tab.
- 12) Order battery trays ([List 94](#)) as required.
- 13) Order [Relay Racks](#) per ACCESSORY DESCRIPTIONS section.
- 14) Order [Distribution Devices](#) per ACCESSORY DESCRIPTIONS section.
- 15) Order [External Battery Disconnect Unit](#) per ACCESSORY DESCRIPTIONS section.
- 16) Order [Battery Cabinet](#) per ACCESSORY DESCRIPTIONS section.
- 17) Order [digital input/relay output cables](#) per ACCESSORY DESCRIPTIONS section.
- 18) Order lugs per [Wiring Notes](#) under ACCESSORY DESCRIPTIONS section.

**List 6: 2RU High by 23” Wide Shelf**

**Features**

- ◆ Consists of a 2RU high by 23” wide shelf.
- ◆ Mounted to the side of the shelf is an AC input housing with plug-in connectors for two (2) AC input feeds.
- ◆ Includes the customer interface board that provides additional relay outputs and digital inputs.
- ◆ The “Relay Outputs Cable” P/N 541308 (shelf side) is factory connected inside the shelf. A mating half is available. A “Digital Input Cable” (shelf side and customer side) is also available.
- ◆ The shelf houses up to six (6) rectifier modules, one (1) controller, and one (1) distribution unit.

**Restrictions**

Each List 6 shelf holds up to six (6) rectifier modules.

**Ordering Notes**

- 1) Order List 6 as required.  
Also order the following as required.
- 2) Order one (1) NCU (P/N [1M830BNA](#)) controller per shelf. Also specify the appropriate configuration file for your site.
- 3) Order up to six (6) rectifier modules per shelf: P/N [1R48500](#) (500W) or P/N [1R481000](#) (1000W).
- 4) Order [AC Input Cables or Line Cords](#) as required. Note that each List 6 shelf requires two (2) AC input cables or line cords.
- 5) Order one (1) distribution unit (List [BF](#), [NF](#), [BC](#), [NC](#), [BA](#), or [NA](#)) per shelf.
- 6) Order one (1) [List 60](#) for each List BC, NC, BA, or NA ordered.  
Each List 60 provides five (5) load lead assemblies for 10A GMT fuse positions.  
Order one (1) [List 61](#) for each List BF or NF ordered.  
Each List 61 provides eight (8) load lead assemblies for 10A GMT fuse positions.  
Order one (1) [List 62](#) for each List BF or NF ordered.  
Each List 62 provides five (5) load lead assemblies for 15A GMT fuse positions.
- 7) Order one (1) [List KG](#) GMT distribution fuse panel per shelf, as required.
- 8) Order three (3) sets of shelf side and three (3) sets of battery side battery cables ([List 65](#) and [List 66](#)) for each List BC, NC, BF, or NF ordered.
- 9) Order up to three (3) [List 67](#) for each List BC, NC, BF, and NF ordered.
- 10) Order relay rack anchor kit(s) ([List 89](#)) as required.
- 11) Order up to two (2) temperature probes ([List 90](#) or [91](#)) as required. One probe is used with the battery charge temperature compensation feature, the other to monitor ambient temperature. See “Optional Temperature Probes” on page 38 for temperature probe options with a mounting tab.
- 12) Order battery trays ([List 93](#)) as required.
- 13) Order [Relay Racks](#) per ACCESSORY DESCRIPTIONS section.
- 14) Order [Distribution Devices](#) per ACCESSORY DESCRIPTIONS section.
- 15) Order [External Battery Disconnect Unit](#) per ACCESSORY DESCRIPTIONS section.
- 16) Order [Battery Cabinet](#) per ACCESSORY DESCRIPTIONS section.
- 17) Order [digital input/relay output cables](#) per ACCESSORY DESCRIPTIONS section.
- 18) Order lugs per [Wiring Notes](#) under ACCESSORY DESCRIPTIONS section.

**List 60: Five (5) Load Lead Assemblies (P/N 535206) for 10A GMT Fuse Positions**

**Features**

- ◆ Provides 12' long, 16 AWG, load and load return leads that are terminated on one end with the appropriate mating connector to plug into the system's 10A GMT fuse connector on a List BC, NC, BA, or NA Distribution Unit, and are left un-terminated at the remaining end for connection into customer loads.

**Restrictions**

For use with List BC, NC, BA, and NA Distribution units only.

**Ordering Notes**

- 1) Order one (1) List 60 for each List BC, NC, BA, or NA Distribution Unit.  
Each List 60 provides five (5) GMT fuse load lead assemblies, P/N 535206.

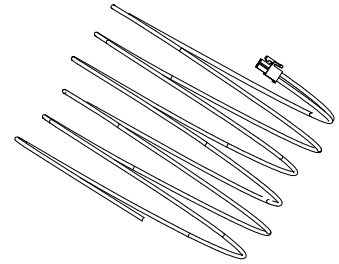

**List 61: Eight (8) Load Lead Assemblies (P/N 535206) for 10A GMT Fuse Positions**

**Features**

- ◆ Provides 12' long, 16 AWG, load and load return leads that are terminated on one end with the appropriate mating connector to plug into the system's 10A GMT fuse connector on a List BF or NF Distribution Unit, and are left un-terminated at the remaining end for connection into customer loads.

**Restrictions**

For use with List BF and NF Distribution units only.

**Ordering Notes**

- 1) Order one (1) List 61 for each List BF or NF Distribution Unit.  
Each List 61 provides eight (8) GMT fuse load lead assemblies, P/N 535206.

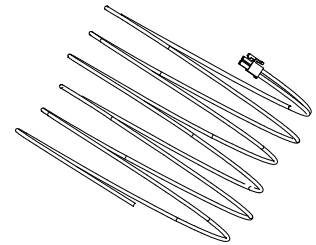

**List 62: Five (5) Load Lead Assemblies (P/N 540988) for 15A GMT Fuse Positions**

**Features**

- ◆ Provides 12' long, 14 AWG, load and load return leads that are terminated on one end with the appropriate mating connector to plug into the system's 15A GMT fuse connector on a List BF or NF Distribution Unit, and are left un-terminated at the remaining end for connection into customer loads.

**Restrictions**

For use with List BF and NF Distribution units only.

**Ordering Notes**

- 1) Order one (1) List 62 for each List BF or NF Distribution Unit.  
Each List 62 provides five (5) GMT fuse load lead assemblies, P/N 540988.

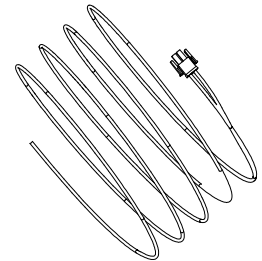

**List 65: Shelf Side Battery Cables, P/N 540814**

**Features**

- ◆ Provides two (2) 3' long, 2 AWG, battery cables terminated in a 2-position Red SB120 Anderson connector (mates with the Anderson connector on List 66). Remaining end terminated in lugs for connection to shelf.

**Restrictions**

For use with List BF, NF, BC, and NC Distribution units only.

**Ordering Notes**

- 1) Order as required. Each shelf provides landings for up to three (3) battery strings.

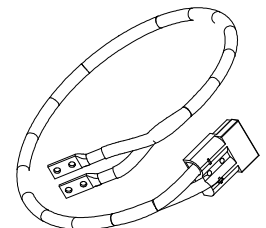

**List 66: Battery Side Battery Cables, P/N 540954**

**Features**

- ◆ Provides two (2) 12' long, 2 AWG, battery cables terminated in a 2-position Red SB120 Anderson connector (mates with the Anderson connector on List 65). Remaining end un-terminated for connection to batteries.

**Restrictions**

For use with List BF, NF, BC, and NC only.

**Ordering Notes**

- 1) Order as required. Each shelf provides landings for up to three (3) battery strings.

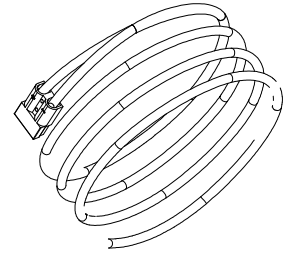

**List 67: Battery Cable, P/N 545709**

**Features**

- ◆ Provides two (2) 4' long, 8 AWG, battery cables terminated in a 2-position Anderson connector on the battery side. Remaining end terminated in lugs for connection to shelf.

**Restrictions**

For use with [P/N 541434](#), [P/N 545534](#), or [P/N 545506](#) battery cabinets only.

For use with List BF, NF, BC, and NC Distribution units only.

**Ordering Notes**

- 1) Order up to three (3) List 67 for each List BC, NC, BF, and NF ordered.
- 2) Order one (1) for each battery cabinet feed required.

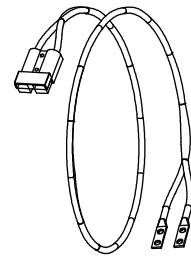

**List 71: Optional External Battery Cable Assembly  
with Anderson Connector for (1) Battery String, P/N 545493**

**Features**

- ◆ Provides two (2) 6' long, 8 AWG, battery cables terminated in a Red SB50 Anderson connector for connecting one (1) battery string to the system.
- ◆ One end of the assembly connects to the Anderson connector factory wired to the shelf's battery connection points, and the other end contains two (2) un-terminated cables for connection into a customer battery string.

**Restrictions**

For use with List BG and NG only.

**Ordering Notes**

- 1) Order if required.
- 2) Order [Spare Anderson Battery Connector](#) per ACCESSORY DESCRIPTIONS section.

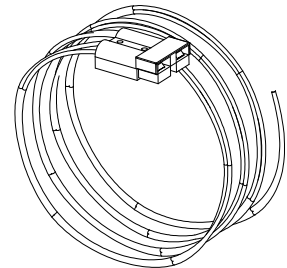



**List 72: Optional External Battery Cable Assembly  
with Anderson Connector for (2) Battery Strings, P/N 535124**

**Features**

- ◆ Provides four (4) 6' long, 10 AWG, battery cables terminated in a Red SB50 Anderson connector for connecting two (2) battery strings to the system.
- ◆ One end of the assembly connects to the Anderson connector factory wired to the shelf's battery connection points, and the other end contains four (4) un-terminated cables for connection into customer battery strings.

**Restrictions**

For use with List BG and NG Distribution units only.

**Ordering Notes**

- 1) Order if required.
- 2) Order [Spare Anderson Battery Connector](#) per ACCESSORY DESCRIPTIONS section.

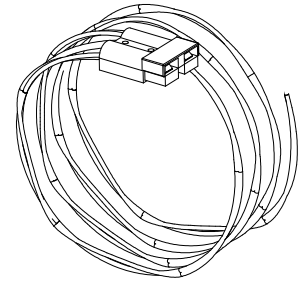

**List 73: Optional External Battery Cable Assembly  
with Anderson Connector for (1) Battery String, P/N 555050**

**Features**

- ◆ Provides two (2) 6' long, 6 AWG, battery cables terminated in a Red SB50 Anderson connector for connecting one (1) battery string to the system.
- ◆ One end of the assembly connects to the Anderson connector factory wired to the shelf's battery connection points, and the other end contains two (2) un-terminated cables for connection into a customer battery string.

**Restrictions**

For use with List BG and NG only.

**Ordering Notes**

- 1) Order if required.
- 2) Order [Spare Anderson Battery Connector](#) per ACCESSORY DESCRIPTIONS section.

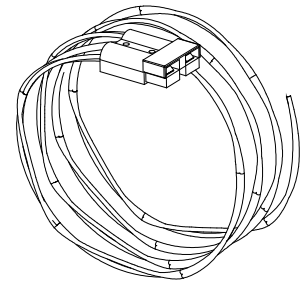

**List 89: Relay Rack Earthquake Anchor Kit, P/N P0987167**

**Features**

- ◆ Provides four (4) sets of hardware for anchoring the relay rack to the floor.

**Ordering Notes**

- 1) Order as required.

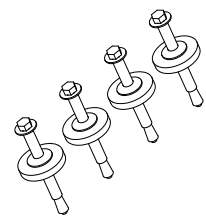

**List 90: Optional Temperature Probe,  
P/N 04118246 (shelf side half) and P/N 04118247 (probe side half, 9 ft. long)**

**Features**

- ◆ Up to two (2) temperature probes can be connected to the Customer Interface (IB2) Board. Either or both probes can be programmed to monitor ambient temperature or battery temperature.
- ◆ A temperature probe set as a battery probe can also be designated to be used for the battery charge temperature compensation feature. If the system is equipped with the ACU+ or NCU Controller, the battery charge temperature compensation feature can be programmed to use one probe or the average or highest value of all probes programmed to monitor battery temperature. The battery charge temperature compensation feature allows the controller to automatically increase or decrease the output voltage of the system to maintain battery float current as battery temperature decreases or increases, respectively. Battery life can be extended when an optimum charge voltage to the battery with respect to temperature is maintained.
- ◆ If the system is equipped with the ACU+ or NCU Controller, a temperature probe set as a battery probe can also be used for controlling against battery thermal runaway (BTRM feature).
- ◆ The Temperature Probe assembly consists of two pieces that plug together to make a complete probe. When ordered, P/N 04118246 (3 feet long) is pre-wired to the shelf and P/N 04118247 (9 feet long) is shipped loose. Total length: 12 ft.



**Restrictions**

A temperature probe programmed to monitor battery temperature should be mounted on the top or side of a battery cell to sense battery temperature. A temperature probe used for battery charge temperature compensation or BTRM (Battery Thermal Runaway Management) should also be mounted on the top or side of a battery cell. A temperature probe programmed to monitor ambient temperature should be mounted in a convenient location, away from direct sources of heat or cold.

**Ordering Notes**

- 1) Order up to two (2) Temperature Probes for each shelf, as required. Each List 90 includes one (1) P/N 04118246 and one (1) P/N 04118247.
- 2) For a Temperature Probe with a longer cable see List 91.
- 3) See “Optional Temperature Probes” on page 38 for temperature probe options with a mounting tab.

**List 91: Optional Temperature Probe,  
P/N 04118246 (shelf side half) and P/N 04116740 (probe side half, 30 ft. long)**

**Features**

- ◆ See above for description of Temperature Probes.
- ◆ The Temperature Probe assembly consists of two pieces that plug together to make a complete probe. When ordered, P/N 04118246 (3 feet long) is pre-wired to the shelf and P/N 04116740 (30 feet long) is shipped loose. Total Length: 33 ft.

**Restrictions**

See above for restrictions.

**Ordering Notes**

- 1) Order up to two (2) Temperature Probes for each shelf, as required. Each List 91 includes one (1) P/N 04118246 and one (1) P/N 04116740.
- 2) For a Temperature Probe with a shorter cable see List 90.
- 3) See “Optional Temperature Probes” on page 38 for temperature probe options with a mounting tab.

**List 93: Battery Tray for 23" Relay Rack**

**Features**

- ◆ Provides one battery tray that mounts four (4) 12V front terminal Valve Regulated Lead Acid (VRLA) batteries. Batteries are configured as one (1) 48V string.
- ◆ Accepts various VRLA batteries. See **Ordering Notes** below.
- ◆ See [Overall Dimensions - 23" Battery Tray](#) under *PHYSICAL SIZE INFORMATION* for battery tray dimensions and typical arrangement. Note that two battery trays are available to accommodate the various size batteries listed in the **Ordering Notes** tables.
- ◆ Trays can be ordered with or without battery disconnect circuit breakers. When circuit breakers are ordered, one is provided in the -48V lead of each battery string (1 circuit breaker per tray).
- ◆ Battery cables are available terminated at the power system end in an Anderson connector. Battery lugs are available for the remaining end.

**Restrictions**

For 23" relay racks only.

Maximum number of List 93's per rack is three (3).

A single List 93 must mount at bottom of rack. Multiple List 93's must mount starting at bottom of rack and working upward.

**Ordering Notes**

- 1) Order multiples of List 93 for more than one (1) battery tray. See **Restrictions** above.
- 2) Order one (1) or more P/N 362736700 Cable Bracket(s) as required.
- 3) Order batteries separately. Tables A, B, and C list the batteries recommended for use with List 93.
- 4) Specify rack spacing of 6U (10.5"), 7U (12.25"), or 8U (14") between trays and above top tray as required for battery clearance. See Tables A, B, and C.
- 5) Battery lugs are provided, as specified from Table D.
- 6) Specify with or without battery disconnect circuit breakers.

**Note:** All List 93 trays in a rack will be furnished with or without battery disconnect circuit breakers as specified for the first tray ordered.

- 7) If ordering List 93 with circuit breakers, order one (1) circuit breaker per List 93 from Table E.
- 8) If ordering List 93 with circuit breakers, specify breaker mounting on left side of tray, right side of tray, or remote mounting. Circuit breaker mounting kits shown in the Table E will be installed. Kit numbers are provided for reference only
- 9) If ordering List 93 with circuit breakers, order Alarm Jumper P/N 524384 for each system to connect the alarm terminal of up to three (3) battery disconnect circuit breakers.

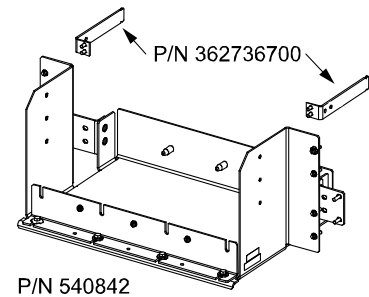
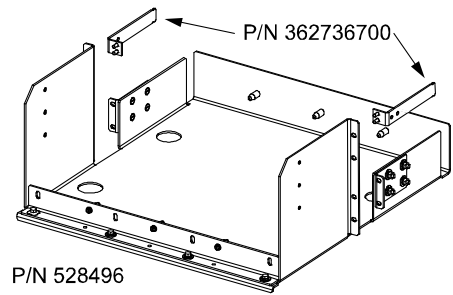
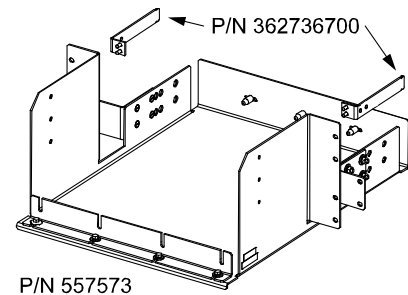

Battery Tray P/N 528496						
Manufacturer <sup>1</sup>	Model	P/N	Rated 8-Hr. Capacity (Ah)	Dimension W x L x H (Inches)	Minimum Tray Spacing	Weight (per battery) (lb)
Northstar	NSB155FT RED	--	155	4.9 x 22.0 x 11.0	7RU	101
Northstar	NSB170FT RED	126111	170	4.9 x 22.0 x 12.6	8RU	116
Northstar	NSB190FT RED	--	190	4.9 x 22.0 x 12.6	8RU	123
Northstar	NSB155FT HT	--	154	4.9 x 22.0 x 11.0	7RU	117
Northstar	NSB170FT HT	--	174	4.9 x 22.0 x 12.6	8RU	121
Northstar	NSB190FT HT	--	190	4.9 x 22.0 x 12.6	8RU	132
Deka Unigy I	12AVR-150ET	122018	150	4.90 x 22.00 x 11.75	8RU	115
Deka Unigy I	12AVR-170ET	541381	170	4.90 x 22.00 x 12.60	8RU	120
Deka Unigy I	HT170ET	--	164	4.93 x 22.17 x 12.58	8RU	118
C&D	TEL12-160F	140456	157	5.0 x 22.0 x 11.1	7RU	116.8
C&D	TEL12-180F	--	181	5.0 x 22.0 x 12.6	8RU	132.3
C&D	TEL12-210F	554579	202	5.0 x 22.0 x 12.6	8RU	132.3
Energysys	12V155FS	122010	155	4.90 x 22.10 x 11.10	7RU	106.9
Energysys	12V170FS	--	170	4.90 x 22.10 x 11.10	7RU	112
Energysys	SBS 170F	--	170	4.92 x 22.10 x 11.10	7RU	116
Energysys	SBS 190F	--	190	4.90 x 22.10 x 12.40	8RU	132
FIAMM	12FAT100	--	100	4.96 x 21.97 x 9.06	6RU	95
FIAMM	12FAT155	--	155	4.96 x 21.97 x 12.64	8RU	129
FIAMM	12FAT180	--	180	4.96 x 21.97 x 12.64	8RU	134
FIAMM	12FHT180	--	180	4.96 x 21.97 x 12.64	8RU	130
GS Yuasa	PYL12V160FT	--	160	4.9 x 21.9 x 11.0	7RU	116.2
GS Yuasa	PYL12V185FT	--	185	4.9 x 21.9 x 12.5	7RU	133.8

\* See [Battery Manufacturer Information](#) located at the end of this document.

Table A

Battery Tray P/N 540842						
Manufacturer*	Model	Vertiv P/N	Rated 8-Hr. Capacity (Ah)	Dimension W x L x H (Inches)	Required Tray Spacing	Weight (per battery) (lbs)
Northstar	NSB40FT**	--	38.1	3.80 X 9.80 X 8.20	6U	34
Northstar	NSB60FT**	--	57.9	4.20 X 11.30 X 10.40	7U	49
Energysys	12TD50F	--	48	4.2 X 10.9 X 8.7	6U	38

\* See [Battery Manufacturer Information](#) located at the end of this document.

\*\* Batteries MUST be equipped with front access terminal option. See Battery Manufacturer for ordering information.

Table B

Battery Tray P/N 557573						
Manufacturer*	Model	Vertiv P/N	Rated 8-Hr. Capacity (Ah)	Dimension W x L x H (Inches)	Required Tray Spacing	Weight (per battery) (lbs)
Enersys	12TD150F	--	143	4.3 X 21.7 X 11.3	8U	105

\* See [Battery Manufacturer Information](#) located at the end of this document.

Table C

Battery Specified	Battery Lug Kit Part Number (Kit provides two lugs for one tray.)		
	Lists 5 and 6	Lists 1 and 2	
Northstar NSB155FT RED	528234		
Northstar NSB170FT RED			
Northstar NSB190FT RED			
Northstar NSB155FT HT			
Northstar NSB170FT HT			
Northstar NSB190FT HT			
Deka Unigy I 12AVR-150ET			
Deka Unigy I 12AVR-170ET			
Deka Unigy I HT170ET	528236		
C&D TEL12-160F			
C&D TEL12-180F			
C&D TEL12-210F	528234		
Enersys 12V155FS			540989 (for use with 10 AWG wire and List 72)
Enersys 12V170FS			545581 (for use with 8 AWG wire and List 71)
Enersys SBS 170F			555069 (for use with 6 AWG wire and List 73)
Enersys SBS 190F			
FIAMM 12FAT100			
FIAMM 12FAT155			
FIAMM 12FAT180			
FIAMM 12FHT180			
GS Yuasa PYL12V160FT			
GS Yuasa PYL12V185FT			
Northstar NSB40FT			
Northstar NSB60FT			
Enersys 12TD50F			
Enersys 12TD150F			

Table D

<b>Ampere Rating</b>	<b>Part No., Circuit Breaker, Electrical/Mechanical Trip<sup>1</sup> (Black Handle)</b>	<b>Part No., Left-Side Breaker Mtg. Kit (For Reference Only)</b>	<b>Part No., Right-Side Breaker Mtg. Kit (For Reference Only)</b>
1	256690300	528501	528500
3	256690700		
5	256691100		
10	256691500		
15	256691900		
20	256692300		
25	256692700		
30	256693100		
35	256693500		
40	256693900		
50	256694300		
60	256694700		
70	256695100		
75	256695500		
100	256695900		

<sup>1</sup> Provides an alarm during an electrical or manual trip condition.

Table E

**List 94: Battery Tray for 19" Relay Rack**

**Features**

- ◆ Provides one battery tray that mounts four (4) 12V front terminal Valve Regulated Lead Acid (VRLA) batteries. Batteries are configured as one (1) 48V string.
- ◆ Accepts various VRLA batteries. See **Ordering Notes** below.
- ◆ See [Overall Dimensions - 19" Battery Tray](#) under *PHYSICAL SIZE INFORMATION* for battery tray dimensions and typical arrangement. Note that three battery trays are available to accommodate the various size batteries listed in the **Ordering Notes** tables.
- ◆ Trays can be ordered with or without battery disconnect circuit breakers. When circuit breakers are ordered, one is provided in the -48V lead of each battery string (1 circuit breaker per tray).
- ◆ Battery cables are available terminated at the power system end in an Anderson connector. Battery lugs are available for the remaining end.

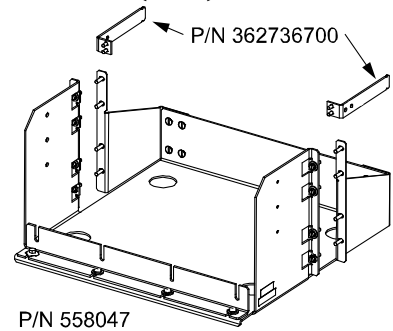

**Restrictions**

For 19" relay racks only.

Maximum number of List 94's per rack is three (3).

A single List 94 must mount at bottom of rack. Multiple List 94's must mount starting at bottom of rack and working upward.

**Ordering Notes**

- 1) Order multiples of List 94 for more than one (1) battery tray. See **Restrictions** above.
- 2) Order one (1) or more P/N 362736700 Cable Bracket(s) as required.
- 3) Order batteries separately. Tables F, G, H and I list batteries recommended for use with List 94.
- 4) Specify rack spacing of 6U (10.5"), 7U (12.25"), or 8U (14") between trays and above top tray as required for battery clearance. See Tables F, G, H and I.
- 5) Battery lugs are provided, as specified from Table J.
- 6) Specify with or without battery disconnect circuit breakers.

**Note:** All List 94 trays in a rack will be furnished with or without battery disconnect circuit breakers as specified for the first tray ordered.

- 7) If ordering List 94 with circuit breakers, order one (1) circuit breaker per List 94 from Table K.
- 8) If ordering List 94 with circuit breakers, specify breaker mounting on left side of tray, right side of tray, or remote mounting. Circuit breaker mounting kits shown in the Table K will be installed. Kit numbers are provided for reference only.
- 9) If ordering List 94 with circuit breakers, order Alarm Jumper P/N 524384 for each system to connect the alarm terminal of up to three (3) battery disconnect circuit breakers.

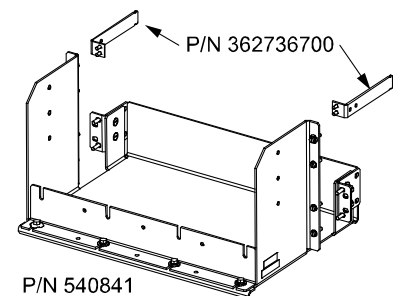
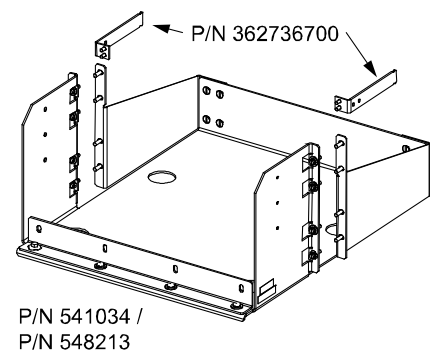

Battery Tray P/N 558047						
Manufacturer*	Model	Vertiv P/N	Rated 8-Hr. Capacity (Ah)	Dimension W x L x H (Inches)	Required Tray Spacing	Weight (per battery) (lbs)
Northstar	NSB90FT	--	90	4.25 X 15.59 X 10.04	7U	71
Northstar	NSB100FT	--	100	4.25 X 15.59 X 11.03	7U	78
Energys	12TD100F4	--	96	4.3 X 15.5 X 11.3	8U	71

\* See [Battery Manufacturer Information](#) located at the end of this document.

Table F

Battery Tray P/N 541034						
Manufacturer*	Model	Vertiv P/N	Rated 8-Hr. Capacity (Ah)	Dimension W x L x H (Inches)	Required Tray Spacing	Weight (per battery) (lbs)
Energys	12TD100F6	--	97	4.3 X 20.0 X 9.4	7U	73

\* See [Battery Manufacturer Information](#) located at the end of this document.

Table G

Battery Tray P/N 540841						
Manufacturer*	Model	Vertiv P/N	Rated 8-Hr. Capacity (Ah)	Dimension W x L x H (Inches)	Required Tray Spacing	Weight (per battery) (lbs)
Northstar	NSB40FT**	--	38.1	3.80 X 9.80 X 8.20	6U	34
Northstar	NSB60FT**	--	57.9	4.20 X 11.30 X 10.40	7U	49
Energys	12TD50F	--	48	4.2 X 10.9 X 8.7	6U	38

\* See [Battery Manufacturer Information](#) located at the end of this document.

\*\* Batteries MUST be equipped with front access terminal option. See Battery Manufacturer for ordering information.

Table H





Battery Tray P/N 548213						
Manufacturer*	Model	Vertiv P/N	Rated 8-Hr. Capacity (Ah)	Dimension W x L x H (Inches)	Required Tray Spacing	Weight (per battery) (lbs)
Enersys	12V125F	122009	125	4.10 X 22.10 X 12.40	8U	124
Enersys	12TD150F	--	143	4.3 X 21.7 X 11.3	8U	105

\* See [Battery Manufacturer Information](#) located at the end of this document.

Table I

Battery Specified	Battery Lug Kit Part Number (Kit provides two lugs for one tray.)	
	Lists 5 and 6	Lists 1 and 2
Northstar NSB90FT	528234	540989 (for use with 10 AWG wire and List 72)
Northstar NSB100FT		
Northstar NSB40FT		
Northstar NSB60FT		545581 (for use with 8 AWG wire and List 71)
Enersys 12V125F		
Enersys 12TD50F		
Enersys 12TD100F4		555069 (for use with 6 AWG wire and List 73)
Enersys 12TD100F6		
Enersys 12TD150F		

Table J

<b>Ampere Rating</b>	<b>Part No., Circuit Breaker, Electrical/Mechanical Trip<sup>1</sup> (Black Handle)</b>	<b>Part No., Left-Side Breaker Mtg. Kit (For Reference Only)</b>	<b>Part No., Right-Side Breaker Mtg. Kit (For Reference Only)</b>
1	256690300	528501	528500
3	256690700		
5	256691100		
10	256691500		
15	256691900		
20	256692300		
25	256692700		
30	256693100		
35	256693500		
40	256693900		
50	256694300		
60	256694700		
70	256695100		
75	256695500		
100	256695900		

<sup>1</sup> Provides an alarm during an electrical or manual trip condition.

Table K

## Distribution Unit

### List BF: Distribution Unit with GMT Fuse Load Distribution Positions and with Low Voltage Battery Disconnect (LVBD)

#### Features

- ◆ Provides a Distribution Unit with Low Voltage Battery Disconnect (LVBD), a battery shunt, (3) battery connection points, and thirteen (13) GMT fuse load distribution positions.
- ◆ Five (5) 0A to 15A GMT fuse load distribution positions.
- ◆ Eight (8) 0A to 10A GMT fuse load distribution positions.

#### Restrictions

For use with List 5 and 6 only.

The (13) Position GMT Fuse Printed Wiring Board is rated 100A at +40°C (+104°F) and 59.5A at 65°C (+149°F).

Unless otherwise specified fuses are mounted from bottom to top, starting with the highest capacity and working to the lowest capacity.

In an ambient of 40°C (+104°F):

- Fuseholders F1-F8 are rated for a 10A fuse maximum. An empty space **is not** required between fuses of any value.
- Fuseholders F9-F13 are rated for a 15A fuse maximum. An empty space **is not** required between fuses of any value. However, 15A fuses **cannot** be placed in adjacent fuseholders. 15A fuses must be separated by a smaller fuse or a space.

In an ambient of 65°C (+149°F):

- Fuseholders F1-F8 are rated for a 10A fuse maximum. An empty space **is** required between 10A fuses. A fuse greater than 3A **cannot** be placed in a fuseholder adjacent to a 10A fuse.
- Fuseholders F9-F13 are rated for a 15A fuse maximum. An empty space **is** required between 15A fuses. 10A fuses **cannot** be placed in adjacent fuseholders. A fuse greater than 3A **cannot** be placed in a fuseholder adjacent to a 10A fuse.

See also the **Restrictions** under “[GMT Load Distribution Fuses](#)” in the ACCESSORY DESCRIPTIONS section.

#### Ordering Notes

- 1) Order one (1) Distribution Unit (List BF, NF, BC, NC, BA, or NA) for each List 5 or 6 shelf. Also order the following as required.
- 2) Order [Distribution Devices](#) per ACCESSORY DESCRIPTIONS section.
- 3) Order one (1) [List 61](#) for each List BF. Each List 61 provides eight (8) GMT fuse load lead assemblies for the 10A fuse blocks.
- 4) Order one (1) [List 62](#) for each List BF. Each List 62 provides five (5) GMT fuse load lead assemblies for the 15A fuse blocks.
- 5) Order Shelf Side, Battery Side Battery Cables or Output Cables ([List 65](#), [List 66](#) or [List 67](#)) as required. List 65 and List 67 are factory installed.
- 6) The controller remains powered when the LVBD contactor opens. Specify if you require List BF to be factory configured for the controller not to be powered when the LVBD contactor opens.

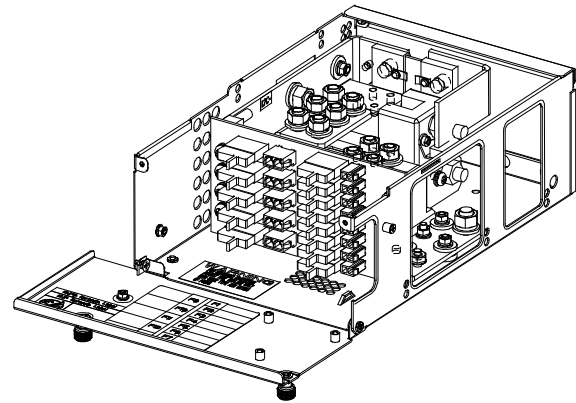

**List NF: Distribution Unit with GMT Fuse Load Distribution Positions  
and w/out Low Voltage Disconnect**

**Features**

- ◆ Provides a Distribution Unit w/out low voltage disconnect, a battery shunt, (3) battery connection points, and thirteen (13) GMT fuse load distribution positions.
- ◆ Five (5) 0A to 15A GMT fuse load distribution positions.
- ◆ Eight (8) 0A to 10A GMT fuse load distribution positions.

**Restrictions**

For use with List 5 and 6 only.

The (13) Position GMT Fuse Printed Wiring Board is rated 100A at +40°C (+104°F) and 59.5A at 65°C (+149°F).

Unless otherwise specified fuses are mounted from bottom to top, starting with the highest capacity and working to the lowest capacity.

In an ambient of 40°C (+104°F):

- Fuseholders F1-F8 are rated for a 10A fuse maximum. An empty space **is not** required between fuses of any value.
- Fuseholders F9-F13 are rated for a 15A fuse maximum. An empty space **is not** required between fuses of any value. However, 15A fuses **cannot** be placed in adjacent fuseholders. 15A fuses must be separated by a smaller fuse or a space.

In an ambient of 65°C (+149°F):

- Fuseholders F1-F8 are rated for a 10A fuse maximum. An empty space **is** required between 10A fuses. A fuse greater than 3A **cannot** be placed in a fuseholder adjacent to a 10A fuse.
- Fuseholders F9-F13 are rated for a 15A fuse maximum. An empty space **is** required between 15A fuses. 10A fuses **cannot** be placed in adjacent fuseholders. A fuse greater than 3A **cannot** be placed in a fuseholder adjacent to a 10A fuse.

See also the **Restrictions** under “[GMT Load Distribution Fuses](#)” in the ACCESSORY DESCRIPTIONS section.

**Ordering Notes**

- 1) Order one (1) Distribution Unit (List BF, NF, BC, NC, BA, or NA) for each List 5 or 6 shelf. Also order the following as required.
- 2) Order [Distribution Devices](#) per ACCESSORY DESCRIPTIONS section.
- 3) Order one (1) [List 61](#) for each List NF. Each List 61 provides eight (8) GMT fuse load lead assemblies for the 10A fuse blocks.
- 4) Order one (1) [List 62](#) for each List NF. Each List 62 provides five (5) GMT fuse load lead assemblies for the 15A fuse blocks.
- 5) Order Shelf Side, Battery Side Battery Cables or Output Cables ([List 65](#), [List 66](#) or [List 67](#)) as required. List 65 and List 67 are factory installed.

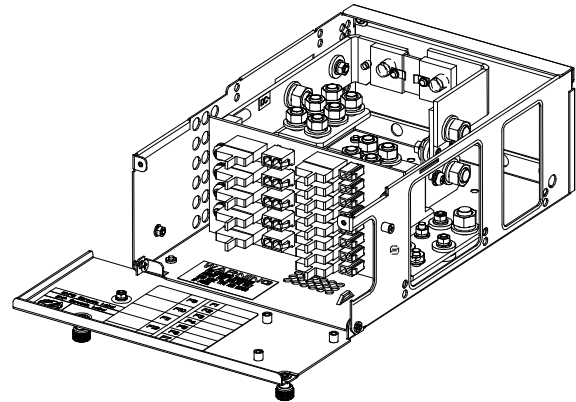

**List BC: Distribution Unit with GMT Fuse Load Distribution Positions, Circuit Breaker Load Distribution Positions, and with Low Voltage Battery Disconnect (LVBD)**

**Features**

- ◆ Provides a Distribution Unit with Low Voltage Battery Disconnect (LVBD), a battery shunt, three (3) battery connection points, four (4) bullet nose-type circuit breaker load distribution positions, five (5) GMT fuse load distribution positions.
- ◆ Five (5) 0A to 10A GMT fuse load distribution positions.

**Restrictions**

For use with List 5 and 6 only.

Maximum distribution current is 72A @ +65°C (+149°F) and 100A @ +40°C (+104°F).

The GMT fuse block has a 35A @ +40°C (+104°F) and a 21A @ +65°C (+149°F) maximum capacity. Maximum GMT fuse size is 10A. At +65°C (+149°F), a space is required between GMT fuses greater than 5A.

Maximum load distribution circuit breaker size is 75A @ +65°C (+149°F).

**Caution:** *In an ambient of +65°C, 50A overcurrent protective devices can be used without a space provided the continuous current in each device does not exceed 36A. Overcurrent protective devices greater than 50A shall have an empty mounting position between it and any other overcurrent protective device. The maximum size overcurrent device used shall be 75A. There are no restrictions for overcurrent devices in an ambient of +40°C.*

See also the **Restrictions** under “[GMT Load Distribution Fuses](#)” and “[Bullet Nose-Type Circuit Breakers](#)” in the ACCESSORY DESCRIPTIONS section.

**Ordering Notes**

- 1) Order one (1) Distribution Unit (List BF, NF, BC, NC, BA, or NA) for each List 5 or 6 shelf. Also order the following as required.
- 2) Order [Distribution Devices](#) per ACCESSORY DESCRIPTIONS section.
- 3) Order one (1) [List 60](#) for each List BC. Each List 60 provides five (5) GMT fuse load lead assemblies for the 10A fuse blocks.
- 4) Order Shelf Side, Battery Side Battery Cables or Output Cables ([List 65](#), [List 66](#) or [List 67](#)) as required. List 65 and List 67 are factory installed.
- 5) Order circuit breaker load lugs per [Wiring Notes](#) under ACCESSORY DESCRIPTIONS section.
- 6) The controller remains powered when the LVBD contactor opens. Specify if you require List BC to be factory configured for the controller not to be powered when the LVBD contactor opens.

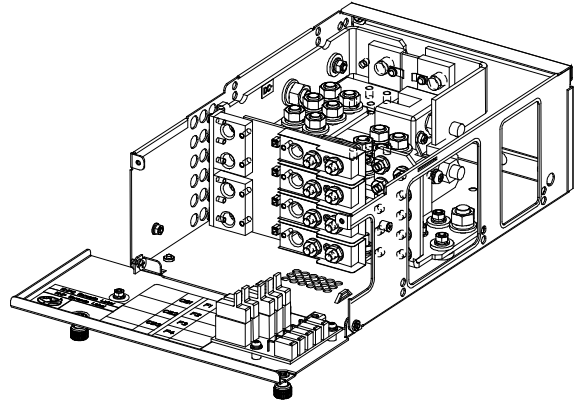

**List NC: Distribution Unit with GMT Fuse Load Distribution Positions, Circuit Breaker Load Distribution Positions, and w/out Low Voltage Disconnect**

**Features**

- ◆ Provides a Distribution Unit w/out low voltage disconnect, a battery shunt, three (3) battery connection points, four (4) bullet nose-type circuit breaker load distribution positions, five (5) GMT fuse load distribution positions.
- ◆ Five (5) 0A to 10A GMT fuse load distribution positions.

**Restrictions**

For use with List 5 and 6 only.

Maximum distribution current is 72A at @ +65°C (+149°F) and 100A @ +40°C (+104°F).

The GMT fuse block has a 35A @ +40°C (+104°F) and a 21A @ +65°C (+149°F) maximum capacity. Maximum GMT fuse size is 10A. At +65°C (+149°F), a space is required between GMT fuses greater than 5A.

Maximum load distribution circuit breaker size is 75A @ +65°C (+149°F).

**Caution:** *In an ambient of +65°C, 50A overcurrent protective devices can be used without a space provided the continuous current in each device does not exceed 36A. Overcurrent protective devices greater than 50A shall have an empty mounting position between it and any other overcurrent protective device. The maximum size overcurrent device used shall be 75A. There are no restrictions for overcurrent devices in an ambient of +40°C.*

See also the **Restrictions** under “[GMT Load Distribution Fuses](#)” and “[Bullet Nose-Type Circuit Breakers](#)” in the ACCESSORY DESCRIPTIONS section.

**Ordering Notes**

- 1) Order one (1) Distribution Unit (List BF, NF, BC, NC, BA, or NA) for each List 5 or 6 shelf. Also order the following as required.
- 2) Order [Distribution Devices](#) per ACCESSORY DESCRIPTIONS section.
- 3) Order one (1) [List 60](#) for each List NC. Each List 60 provides five (5) GMT fuse load lead assemblies for the 10A fuse blocks.
- 4) Order Shelf Side, Battery Side Battery Cables or Output Cables ([List 65](#), [List 66](#) or [List 67](#)) as required. List 65 and List 67 are factory installed.
- 5) Order circuit breaker load lugs per [Wiring Notes](#) under ACCESSORY DESCRIPTIONS section.

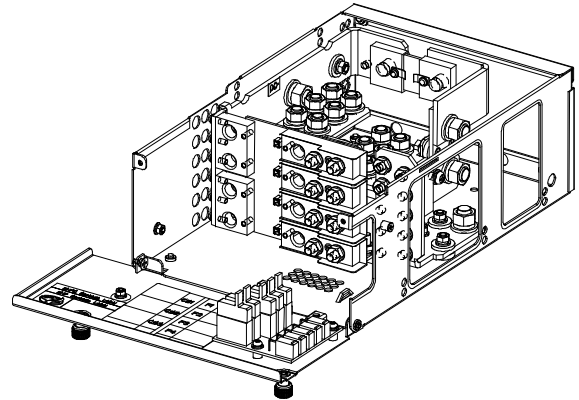

**List BA: Distribution Unit with GMT Fuse Load Distribution Positions,  
Circuit Breaker Load Distribution Positions, Circuit Breaker Battery Disconnect Positions,  
and with Low Voltage Battery Disconnect (LVBD)**

**Features**

- ◆ Provides a Distribution Unit with Low Voltage Battery Disconnect (LVBD), a battery shunt, two (2) bullet nose-type circuit breaker load distribution positions, two (2) bullet nose-type circuit breaker battery disconnect positions, five (5) GMT fuse load distribution positions.
- ◆ Five (5) 0A to 10A GMT fuse load distribution positions.

**Restrictions**

For use with List 5 and 6 only.

Maximum distribution current is 72A at @ +65°C (+149°F) and 100A @ +40°C (+104°F).

The GMT fuse block has a 35A @ +40°C (+104°F) and a 21A @ +65°C (+149°F) maximum capacity. Maximum GMT fuse size is 10A.

At +65°C (+149°F), a space is required between GMT fuses greater than 5A.

Maximum load distribution or battery circuit breaker size is 75A @ +65°C (+149°F).

**Caution:** *In an ambient of +65°C, 50A overcurrent protective devices can be used without a space provided the continuous current in each device does not exceed 36A. Overcurrent protective devices greater than 50A shall have an empty mounting position between it and any other overcurrent protective device. The maximum size overcurrent device used shall be 75A. There are no restrictions for overcurrent devices in an ambient of +40°C.*

See also the **Restrictions** under “[GMT Load Distribution Fuses](#)” and “[Bullet Nose-Type Circuit Breakers](#)” in the ACCESSORY DESCRIPTIONS section.

**Ordering Notes**

- 1) Order one (1) Distribution Unit (List BF, NF, BC, NC, BA, or NA) for each List 5 or 6 shelf. Also order the following as required.
- 2) Order [Distribution Devices](#) per ACCESSORY DESCRIPTIONS section.
- 3) Order one (1) [List 60](#) for each List BA. Each List 60 provides five (5) GMT fuse load lead assemblies for the 10A fuse blocks.
- 4) Order circuit breaker load lugs and battery input lugs per [Wiring Notes](#) under ACCESSORY DESCRIPTIONS section.
- 5) The controller remains powered when the LVBD contactor opens. Specify if you require List BA to be factory configured for the controller not to be powered when the LVBD contactor opens.

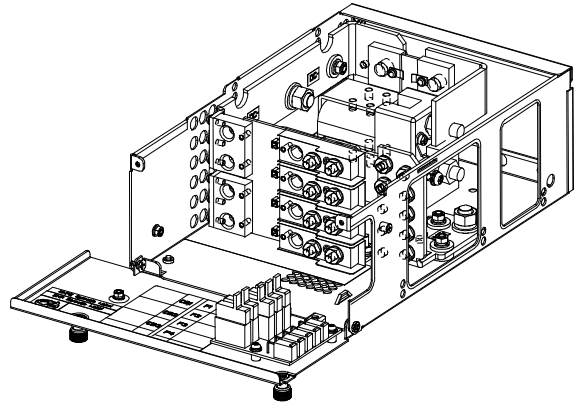

**List NA: Distribution Unit with GMT Fuse Load Distribution Positions,  
Circuit Breaker Load Distribution Positions, Circuit Breaker Battery Disconnect Positions,  
and w/out Low Voltage Disconnect**

**Features**

- ◆ Provides a Distribution Unit w/out low voltage disconnect, a battery shunt, two (2) bullet nose-type circuit breaker load distribution positions, two (2) bullet nose-type circuit breaker battery disconnect positions, five (5) GMT fuse load distribution positions.
- ◆ Five (5) 0A to 10A GMT fuse load distribution positions.

**Restrictions**

For use with List 5 and 6 only.

Maximum distribution current is 72A at @ +65°C (+149°F) and 100A @ +40°C (+104°F).

The GMT fuse block has a 35A @ +40°C (+104°F) and a 21A @ +65°C (+149°F) maximum capacity. Maximum GMT fuse size is 10A. At +65°C (+149°F), a space is required between GMT fuses greater than 5A.

Maximum load distribution or battery circuit breaker size is 75A @ +65°C (+149°F).

**Caution:** *In an ambient of +65°C, 50A overcurrent protective devices can be used without a space provided the continuous current in each device does not exceed 36A. Overcurrent protective devices greater than 50A shall have an empty mounting position between it and any other overcurrent protective device. The maximum size overcurrent device used shall be 75A. There are no restrictions for overcurrent devices in an ambient of +40°C.*

See also the **Restrictions** under “[GMT Load Distribution Fuses](#)” and “[Bullet Nose-Type Circuit Breakers](#)” in the ACCESSORY DESCRIPTIONS section.

**Ordering Notes**

- 1) Order one (1) Distribution Unit (List BF, NF, BC, NC, BA, or NA) for each List 5 or 6 shelf. Also order the following as required.
- 2) Order [Distribution Devices](#) per ACCESSORY DESCRIPTIONS section.
- 3) Order one (1) [List 60](#) for each List NA. Each List 60 provides five (5) GMT fuse load lead assemblies for the 10A fuse blocks.
- 4) Order circuit breaker load lugs and battery input lugs per [Wiring Notes](#) under ACCESSORY DESCRIPTIONS section.

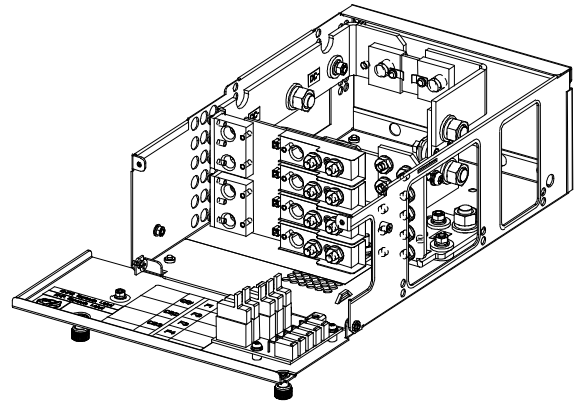



**List BG: Distribution Unit with GMT Fuse Load Distribution Positions  
and with Low Voltage Battery Disconnect (LVBD)**

**Features**

- ◆ Provides a Distribution Unit with Low Voltage Battery Disconnect (LVBD), battery cables, and ten (10) GMT fuse load distribution positions (15A maximum).
- ◆ Two (2) 8 AWG 48" long battery cables are factory connected inside the shelf. These cables are terminated at the customer end in a Red SB50 Anderson battery connector. A mating Anderson battery connector is provided [Housing: Vertiv P/N 138922, Anderson Power Products P/N 992G1. Contacts (two provided): Vertiv P/N 247109602, Anderson Power Products P/N 5952].
- ◆ Ten (10) 0A to 15A GMT fuse load distribution positions.

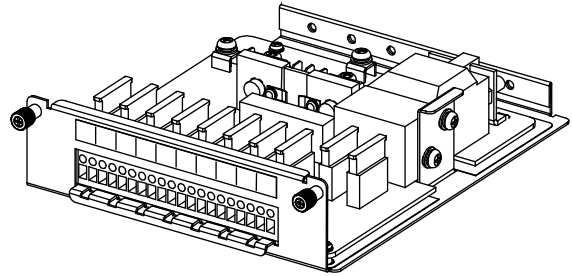

**Restrictions**

For use with List 1 and 2 only.

The Distribution Unit has a 50A @ +40°C (+104°F) and 40A @ +65°C (+149°F) maximum capacity. Maximum GMT fuse size is 15A. In an ambient of +65°C (+149°F), an empty space is required between 15A fuses.

See also the **Restrictions** under "[GMT Load Distribution Fuses](#)" in the ACCESSORY DESCRIPTIONS section.

**Ordering Notes**

- 1) Order one (1) Distribution Unit (List BG or NG) for each List 1 or 2 shelf. Also order the following as required.
- 2) Order [Distribution Devices](#) per ACCESSORY DESCRIPTIONS section.
- 3) Order Optional External Battery Cables with Anderson Connector for one (1) to two (2) Battery Strings per List [71](#), [72](#) or [73](#).
- 4) Order [Spare Anderson Battery Connector](#) per ACCESSORY DESCRIPTIONS section.

**List NG: Distribution Unit with GMT Fuse Load Distribution Positions  
and w/out Low Voltage Disconnect**

**Features**

- ◆ Provides a Distribution Unit w/out low voltage disconnect, a battery shunt, battery cables, and ten (10) GMT fuse load distribution positions (15A maximum).
- ◆ Two (2) 8 AWG 48" long battery cables are factory connected inside the shelf. These cables are terminated at the customer end in a Red SB50 Anderson battery connector. A mating Anderson battery connector is provided [Housing: Vertiv P/N 138922, Anderson Power Products P/N 992G1. Contacts (two provided): Vertiv P/N 247109602, Anderson Power Products P/N 5952].
- ◆ Ten (10) 0A to 15A GMT fuse load distribution positions.

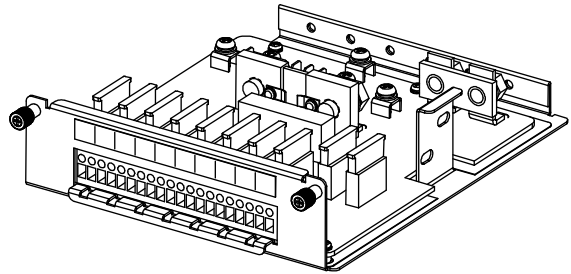

**Restrictions**

For use with List 1 and 2 only.

The Distribution Unit has a 50A @ +40°C (+104°F) and 40A @ +65°C (+149°F) maximum capacity. Maximum GMT fuse size is 15A. In an ambient of +65°C (+149°F), an empty space is required between 15A fuses.

See also the **Restrictions** under "[GMT Load Distribution Fuses](#)" in the ACCESSORY DESCRIPTIONS section.

**Ordering Notes**

- 1) Order one (1) Distribution Unit (List BG or NG) for each List 1 or 2 shelf. Also order the following as required.
- 2) Order [Distribution Devices](#) per ACCESSORY DESCRIPTIONS section.
- 3) Order Optional External Battery Cables with Anderson Connector for one (1) to two (2) Battery Strings per List [71](#), [72](#) or [73](#).
- 4) Order [Spare Anderson Battery Connector](#) per ACCESSORY DESCRIPTIONS section.

**List KG: Distribution Panel with (20) GMT Fuse Load Distribution Positions**

**Features**

- ◆ 1U-high GMT fuse panel that provides Single Load Distribution (-48V)
- ◆ Provides twenty (20) 0A to 15A GMT fuse load distribution positions.

**Caution:** *At +40°C and +65°C ambient, a fuse with a rating of greater than 10 amperes SHALL HAVE an empty mounting position between it and any other fuse.*

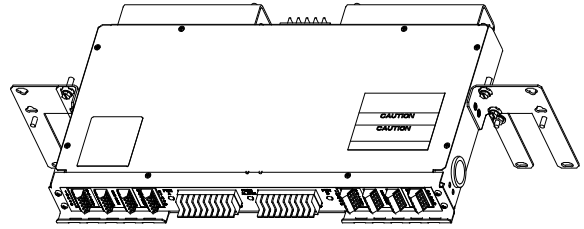

- ◆ Maximum Capacity: 80A @ +40°C and 80A @ +65°C
- ◆ Factory mounted and connected to List 5 or 6 shelf.
- ◆ If the Distribution Unit in the system is equipped with Low Voltage Load Disconnect (LVLD), all List KG loads are disconnected.
- ◆ If one or more distribution fuses opens, one set of Form-C relay contacts changes state, and resistive battery is provided to an alarm terminal. Alarm circuit is factory connected to activate the Power System Controller fuse alarm

**Restrictions**

For use with List 5 and 6 only.

Mounts only immediately above List 5 or 6 shelf.

Maximum distribution current is 80A.

See also the **Restrictions** under "[GMT Load Distribution Fuses](#)" in the ACCESSORY DESCRIPTIONS section.

**Ordering Notes**

- 1) Order one (1) List KG GMT Distribution Fuse Panel Assembly for each List 5 or 6 shelf as required. Also order the following as required.
- 2) Order [GMT Load Distribution Fuses](#) per ACCESSORY DESCRIPTIONS section.

## ACCESSORY DESCRIPTIONS

### Relay Racks

#### Features

- ◆ The following relay racks are available.

#### Restrictions

Customer must mount Power/Distribution Shelf in relay rack. If battery trays are ordered, they are factory mounted in the relay rack.

#### Ordering Notes

- 1) Order from relay racks listed in Table 1.

Part Number	Size	Available Mounting Positions (1RU = 1-3/4")	Notes
<b>23" Relay Racks</b>			
559817	51-3/8" H x 23" W	28RU	Welded
559818	6'0" H x 23" W	37RU	Welded
559819	7'0" H x 23" W	45RU	Seismic (Note 1)
559820	7'0" H x 23" W	45RU	Welded
559821	7'6" H x 23" W	48RU	Welded
559822	8'0" H x 23" W	51RU	Welded
<b>19" Relay Racks</b>			
559823	7'0" H x 19" W	45RU	Seismic (Note 1)
559824	7'0" H x 19"W	45RU	Welded

**Note 1:** Complies with Bellcore Seismic Zone 4 requirements.

Table 1  
Available Relay Racks

## Rectifier

### **Rectifier Module (500W), P/N 1R48500**

#### **Features**

- ◆ Provides one (1) Model R48-500, Spec. No. 1R48500, 500 watt / 48 volt rectifier module.

#### **Restrictions**

Each List 1 Shelf holds up to two (2) rectifier modules.  
Each List 2 Shelf holds up to three (3) rectifier modules.  
Each List 5 Shelf holds up to four (4) rectifier modules.  
Each List 6 Shelf holds up to six (6) rectifier modules.  
DO NOT install different wattage rectifier modules in same shelf.

#### **Ordering Notes**

- 1) Order by P/N (1R48500) as required.

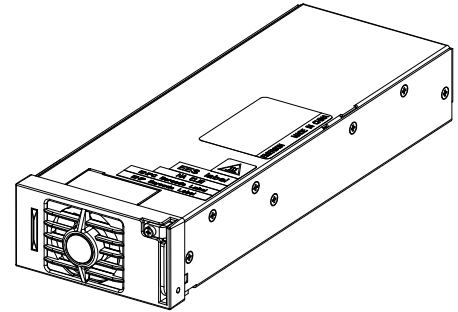

### **Rectifier Module (1000W), P/N 1R481000**

#### **Features**

- ◆ Provides one (1) Model R48-1000, Spec. No. 1R481000, 1000 watt / 48 volt rectifier module.

#### **Restrictions**

Each List 1 Shelf holds up to two (2) rectifier modules.  
Each List 2 Shelf holds up to three (3) rectifier modules.  
Each List 5 Shelf holds up to four (4) rectifier modules.  
Each List 6 Shelf holds up to six (6) rectifier modules.  
DO NOT install different wattage rectifier modules in same shelf.

#### **Ordering Notes**

- 1) Order by P/N (1R481000) as required.

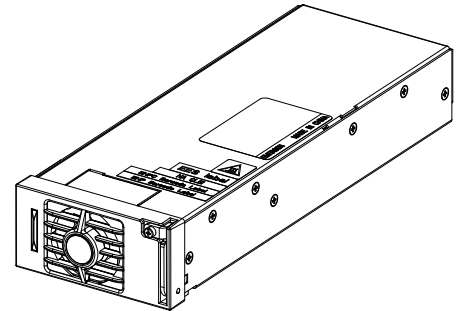

## Controller

### NCU (NetSure™ Control Unit), P/N 1M830BNA

#### Features

- ◆ Provides the NCU Controller.
- ◆ Factory programmed with the configuration file specified when ordered.

#### Restrictions

Each shelf must contain one (1) controller.

#### Ordering Notes

- 1) Order one (1) controller for each shelf.

**Note:** The controller is provided with the factory default configuration unless otherwise specified.

- 2) Ordering an NCU for replacing an NCU or as a spare NCU.

If the NCU is to be used as a replacement in a specific system it should be ordered with the same configuration file as the original NCU controller. This is identified by a six digit number. If the controller part number ends with a six digit number, for example, 1M830BNA559242, the configuration file number is the last six characters. If the part number does not have these characters, the configuration file number can be found on the controller nameplate – “Programmed with Configuration File #####”. The user manual provided with the controller provides instructions for replacing and programming the controller. It is important to follow these instructions carefully. The user manual also provides instructions for saving certain controller files that are created when changes are made to the system after leaving the factory. These files can be programmed into the replacement controller so it can match the latest saved state of the original controller.

If the NCU is being ordered as a spare part for any of a group of power plants, the same procedure can be followed. If the replacement controller’s configuration does not match that of the original controller, contact the factory or technical assistance center to obtain a copy of the original configuration file (all package) so it can be programmed into the new controller.

The NCU programming files are unique to the NCU. Files from an SCU+ or ACU+ are not compatible with the NCU and MUST NOT BE loaded into an NCU.

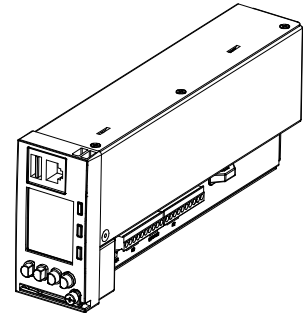

## Optional Temperature Probes

#### Features

- ◆ Up to two (2) temperature probes can be connected to the Customer Interface (IB2) Board. Either or both probes can be programmed to monitor ambient temperature or battery temperature.
- ◆ A temperature probe set as a battery probe can also be designated to be used for the battery charge temperature compensation feature. If the system is equipped with the ACU+ or NCU Controller, the battery charge temperature compensation feature can be programmed to use one probe or the average or highest value of all probes programmed to monitor battery temperature. The battery charge temperature compensation feature allows the controller to automatically increase or decrease the output voltage of the system to maintain battery float current as battery temperature decreases or increases, respectively. Battery life can be extended when an optimum charge voltage to the battery with respect to temperature is maintained.
- ◆ If the system is equipped with the ACU+ or NCU Controller, a temperature probe set as a battery probe can also be used for controlling against battery thermal runaway (BTRM feature).
- ◆ The temperature sensor end of the probe contains a tab with a 5/16” clearance hole for mounting.
- ◆ The Temperature Probe assembly consists of two pieces that plug together to make a complete probe.

#### Restrictions

A temperature probe programmed to monitor battery temperature should be mounted on the top or side of a battery cell to sense battery temperature. A temperature probe used for battery charge temperature compensation or BTRM (Battery Thermal Runaway Management) should also be mounted on the top or side of a battery cell. A temperature probe programmed to monitor ambient temperature should be mounted in a convenient location, away from direct sources of heat or cold.

#### Ordering Notes

- 1) Order temperature probes as required. Note that each temperature probe consists of two pieces, which plug together to make a complete probe (see the following illustration). For a complete temperature probe, order one (1) P/N 552992 (10.3 meters) or one (1) P/N 556155 (3.3 meters).
- 2) See “[List 90](#)” on page 18 and “[List 91](#)” on page 18 for additional temperature probe options.

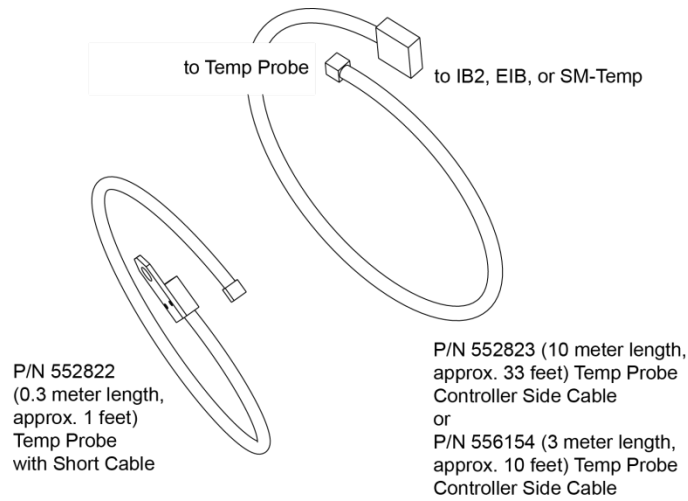

Temp Probe Kits

P/N 552992 (includes P/Ns 552822 and 552823)

P/N 556155 (includes P/Ns 552822 and 556154)

## Mounting and Adapter Kits

### Optional Wall Mount Bracket Kit for Lists 1 and 2, P/N 541285

#### **Features**

- ◆ Allows for horizontal or vertical wall mounting.
- ◆ See [Physical Size Information](#) for mounting dimensions.

#### **Restrictions**

For use with List 1 or 2 only.

Customer must supply mounting fasteners for securing the Wall Mount Bracket to the wall.

This Kit will not support wall mounting when the 58213660001 and 58213660002 shelves are flush mounted.

#### **Ordering Notes**

- 1) Order P/N 541285, which consists of two (2) P/N 545701 horizontal wall mounting brackets and two (2) P/N 541284 vertical wall mounting brackets, and eight (8) 12-24 x ½” screws for attaching the brackets to the shelf.

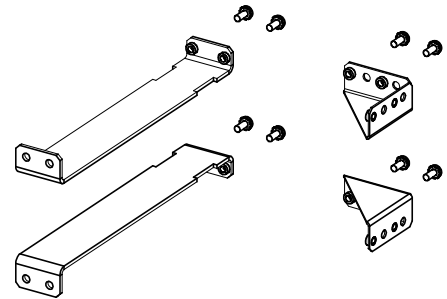

### Optional Wall Mount Bracket Kit for Lists 1, 2, 5 and 6, P/N 553203

#### **Features**

- ◆ Allows for vertical wall mounting.
- ◆ See [Physical Size Information](#) for mounting dimensions.

#### **Restrictions**

Customer must supply mounting fasteners for securing the Wall Mount Brackets to the wall.

#### **Ordering Notes**

- 1) Order P/N 553203, which consists of two (2) wall brackets (P/N 553058 and 553059) and eight (8) 12-24 x ¾” screws with four (4) ground washers for attaching the brackets to the shelf.

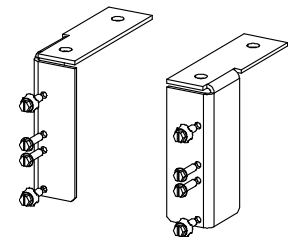

### Optional 19” to 23” 1RU Rack Adapter Kit, P/N 540993

#### **Features**

- ◆ Allows for 23” 1RU relay rack mounting

#### **Restrictions**

For use with List 1 only.

#### **Ordering Notes**

- 1) Order P/N 540993, which consists of two (2) P/N 540994 adapters and four (4) 12-24 x 1/”2 thread forming screws.

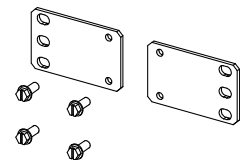

### Optional 19” to 23” 2RU Rack Adapter Kit, P/N 545728

#### **Features**

- ◆ Allows for 23” 2RU relay rack mounting

#### **Restrictions**

For use with List 5 only.

#### **Ordering Notes**

- 1) Order P/N 545728, which consists of two (2) P/N 545727 adapters and four (4) 12-24 x 1/”2 thread forming screws.

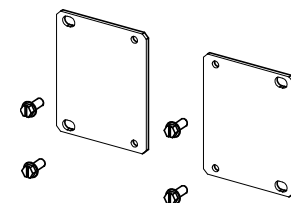



**Optional 19" Rear Cover Kit, P/N 555260**

**Features**

- ◆ Allows for 19" 1RU flush rack mount configuration
- ◆ AC input unit is moved to the rear panel

**Restrictions**

For use with List 1 only.

**Ordering Notes**

- 1) Order P/N 555260, which consists of one (1) P/N 553271 19" rear cover assembly, one (1) P/N 29041838 caution label and one (1) P/N PSK04118562 AC input jumper.

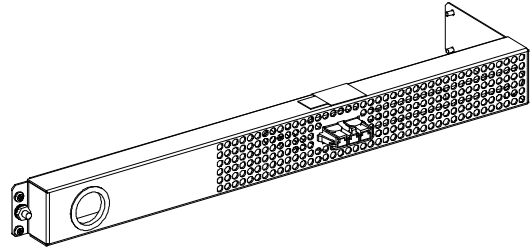

**Rear Battery Cable Exit Kit P/N 547645**

**Features**

- ◆ Provides 12" battery cables exiting rear of shelf

**Restrictions**

For use with List 5 only.

**Ordering Notes**

- 1) For use with [Battery Cabinets](#) only.

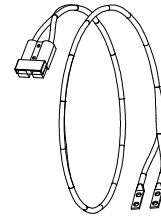

## Distribution Devices

### GMT Load Distribution Fuses

#### Features

- ◆ Each List BF and NF Distribution Unit holds up to five (5) 0-15A GMT load distribution fuses and eight (8) 0-10A GMT load distribution fuses.
- ◆ Each List BC, NC, BA, NA Distribution Unit holds up to five (5) 0-10A GMT load distribution fuses.
- ◆ Each List BG and NG Distribution Unit holds up to ten (10) 0-15A GMT load distribution fuses.
- ◆ Each List KG Distribution Panel holds up to twenty (20) 0-15A GMT load distribution fuses.

#### Restrictions

When used for power distribution, load should not exceed 80% of device rating, except 10 and 15 ampere fuses, for which load should not exceed 70% of device rating.

See also the **Restrictions** for each Distribution Unit in the LIST DESCRIPTIONS section.

See also [Load Distribution Wiring \(GMT Fuses\) \(Lists BG and NG only\)](#), [Load Distribution Wiring \(GMT Fuses\) \(Lists BF and NF only\)](#), and [Load Distribution Wiring \(GMT Fuses\) \(Lists BC, NC, BA, and NA\)](#) under [Wiring Notes](#) for additional wiring restrictions.

#### Ordering Notes

- 1) Order GMT fuses per Table 2.

Ampere Rating		P/N	Fuse Color
18/100 GMT-A		248610301	--
1/4		248610200	Violet
1/2		248610300	Red
3/4		248610500	Brown
1-1/3		248610700	White
2		248610800	Orange
3		248610900	Blue
5		248611000	Green
7-1/2		248611300	Black-White
10		248611200	Red-White
15		248611500	Red-Blue
Replacement Dummy Fuse		248872600	---
Replacement Safety Fuse Cover	Lists BF, NF, BC, NC, BA, NA and KG	102774	--
	Lists BG and NG	248898700	

Table 2  
GMT Fuses

**Bullet Nose-Type Circuit Breakers**

**Features**

- ◆ Each List BC, and NC Distribution Unit holds up to four (4) bullet nose-type load distribution circuit breakers.
- ◆ Each List BA and NA Distribution Unit holds up to two (2) bullet nose-type battery disconnect circuit breakers and up to two (2) bullet nose-type load distribution circuit breakers.

**Restrictions**

See also the **Restrictions** for each Distribution Unit in the LIST DESCRIPTIONS section.

See also [Load Distribution Wiring \(Circuit Breakers\) \(Lists BC, NC, BA, and NA\)](#) and [Input Battery Wiring \(to Battery Disconnect Circuit Breakers\) \(Lists BA and NA\)](#) under WIRING NOTES for additional wiring restrictions.

**Ordering Notes**

- 1) Order circuit breakers per Table 3.

Ampere Rating	P/N	
	Electrical Trip <sup>1</sup> (White Handle)	Electrical/ Mechanical Trip <sup>2</sup> (Black Handle)
1	102272	101596
3	102273	101597
5	102274	101598
10	102275	101599
15	102276	101600
20	102277	101601
25	102278	101602
30	102279	101603
35	102280	101604
40	102281	101605
45	121998	121997
50	102282	101606
60	102283	101607
70	102284	101608
75	102285	101609
80	121996	121995
90	138887	138888
100	102286	101610
See Table 5 for recommended wire sizes and lugs.		

Circuit Breaker Alarm Operation:

- <sup>1</sup> Provides an alarm during an electrical trip condition only.
- <sup>2</sup> Provides an alarm during an electrical or manual trip condition.

Note that Electrical Trip only circuit breakers are not typically used for battery disconnect circuit breakers.

Table 3  
Bullet Nose-Type Circuit Breakers

### Optional Bullet Nose 6-Position GMT Fuse Module, P/N 545332

#### Features

- ◆ Factory installed in a List BC, NC, BA, and NA Distribution Unit.
- ◆ Provides six (6) 0A to 15A GMT fuse load distribution positions.
- ◆ Screw clamp type load and load return terminals provided.
- ◆ Includes six (6) dummy fuses equipped with safety fuse covers.

#### Restrictions

For use with Lists BC, NC, BA, and NA.

Terminal block wire size capacity: 24 to 14 AWG.

Requires two (2) bullet device mounting positions.

Fuse Module has a 30A @ +40°C (+104°F) and +65°C

(+149°F) maximum capacity. Maximum GMT fuse size is 15A. Fuses are to be loaded from bottom to top with highest value in the lowest position.

**Caution:** *A fuse with a rating greater than 10 amperes SHALL HAVE an empty mounting position between it and any other overcurrent protective device.*

See also the **Restrictions** under “[GMT Load Distribution Fuses](#)” in the ACCESSORY DESCRIPTIONS section.

Factory installed only.

#### Ordering Notes

- 1) Order optional Bullet Nose-Type 6-Position GMT Fuse Module (P/N 545332) as required.
- 2) Order GMT fuses as required per Table 2.

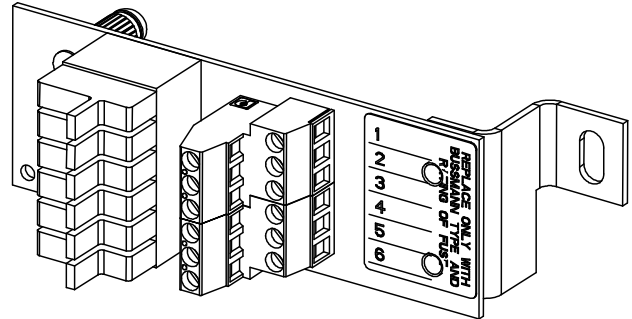

### Optional Bulk Output Busbar, P/N 535015

#### Features

- ◆ Each Bulk Output Busbar installs in a single circuit breaker position in a List BC, NC, BA, and NA Distribution Unit.

#### Restrictions

For use with Lists BC, NC, BA, and NA.

#### Ordering Notes

- 1) Order by P/N 535015 as required.

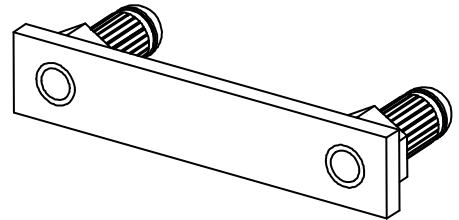

## AC Input Cables and Line Cords

### AC Input Cable Assembly, P/N 535232

#### **Features**

- ◆ Provides one (1) 30" long, 8 AWG, AC Input Cable Assembly;
  - ◆ terminated on one end with a Molex plug, which mates with AC input receptacle on the Power/Distribution Shelf,
  - ◆ and the remaining end un-terminated.

#### **Restrictions**

Rated for 30A.

For use with List 1, 2, 5, and 6.

Each List 1 and 2 requires one (1) AC Input Cable Assembly/Line Cord.

Each List 5 and 6 requires two (2) AC Input Cable Assemblies/Line Cords.

#### **Ordering Notes**

- 1) Order one (1) AC Input Cable Assembly/Line Cord as required for each List 1 and 2 ordered.
- 2) Order two (2) AC Input Cable Assemblies/Line Cords as required for each List 5 and 6 ordered.

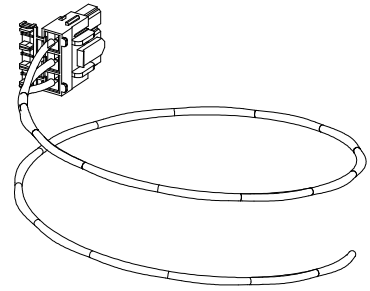

### AC Input Line Cord, 208/240VAC, P/N 540946

#### **Features**

- ◆ Provides one (1) 14' long, 8 AWG, AC Input Line Cord;
  - ◆ terminated on one end with a Molex plug, which mates with AC input receptacle on the Power/Distribution Shelf,
  - ◆ and on the remaining end with a NEMA L6-30P twist-lock plug.

#### **Restrictions**

For 208/240 VAC only (rated for 30A at 208/240VAC).

For use with List 1, 2, 5, and 6.

Each List 1 and 2 requires one (1) AC Input Cable Assembly/Line Cord.

Each List 5 and 6 requires two (2) AC Input Cable Assemblies/Line Cords.

#### **Ordering Notes**

- 1) Order one (1) AC Input Cable Assembly/Line Cord as required for each List 1 and 2 ordered.
- 2) Order two (2) AC Input Cable Assemblies/Line Cords as required for each List 5 and 6 ordered.

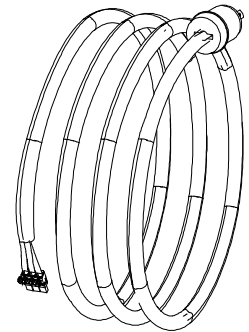

### AC Input Line Cord, 208/240VAC, P/N 559301

#### **Features**

- ◆ Provides one (1) 14' long, 8 AWG, AC Input Line Cord;
  - ◆ terminated on one end with a Molex plug at a 90 degree angle bend, which mates with AC input receptacle on the Power/Distribution Shelf,
  - ◆ and on the remaining end with a NEMA L6-30P twist-lock plug.

#### **Restrictions**

For 208/240 VAC only (rated for 30A at 208/240VAC).

For use with List 1, 2, 5, and 6.

Each List 1 and 2 requires one (1) AC Input Cable Assembly/Line Cord.

Each List 5 and 6 requires two (2) AC Input Cable Assemblies/Line Cords.

#### **Ordering Notes**

- 1) Order one (1) AC Input Cable Assembly/Line Cord as required for each List 1 and 2 ordered.
- 2) Order two (2) AC Input Cable Assemblies/Line Cords as required for each List 5 and 6 ordered.

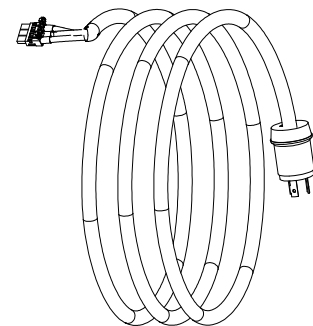

**AC Input Line Cord, 208/240VAC, P/N 545616**

**Features**

- ◆ Provides one (1) 6' long, 8 AWG, AC Input Line Cord;
  - ◆ terminated on one end with a Molex plug, which mates with AC input receptacle on the Power/Distribution Shelf,
  - ◆ and on the remaining end with a NEMA L6-30P twist-lock plug.

**Restrictions**

For 208/240 VAC only (rated for 30A at 208/240VAC).

For use with List 1, 2, 5, and 6.

Each List 1 and 2 requires one (1) AC Input Cable Assembly/Line Cord.

Each List 5 and 6 requires two (2) AC Input Cable Assemblies/Line Cords.

**Ordering Notes**

- 1) Order one (1) AC Input Cable Assembly/Line Cord as required for each List 1 and 2 ordered.
- 2) Order two (2) AC Input Cable Assemblies/Line Cords as required for each List 5 and 6 ordered.

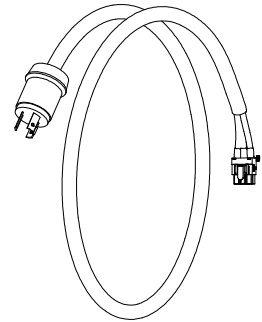

**AC Input Line Cord, 208/240VAC, P/N 559842**

**Features**

- ◆ Provides one (1) 6' long, 8 AWG, AC Input Line Cord;
  - ◆ terminated on one end with a Molex plug (wires molded 180° from plug orientation), which mates with AC input receptacle on the Power/Distribution Shelf,
  - ◆ and on the remaining end with a NEMA L6-30P twist-lock plug.

**Restrictions**

For 208/240 VAC only (rated for 30A at 208/240VAC).

For use with List 1, 2, 5, and 6.

Each List 1 and 2 requires one (1) AC Input Cable Assembly/Line Cord.

Each List 5 and 6 requires two (2) AC Input Cable Assemblies/Line Cords.

**Ordering Notes**

- 1) Order one (1) AC Input Cable Assembly/Line Cord as required for each List 1 and 2 ordered.
- 2) Order two (2) AC Input Cable Assemblies/Line Cords as required for each List 5 and 6 ordered.

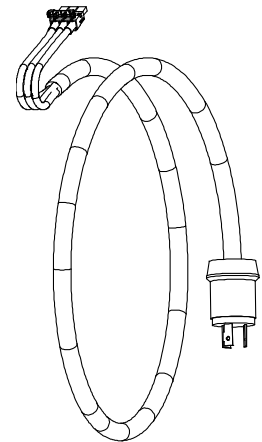

**AC Input Line Cord, 208/240VAC, P/N 559302**

**Features**

- ◆ Provides one (1) 6' long, 8 AWG, AC Input Line Cord;
  - ◆ terminated on one end with a Molex plug at a 90 degree angle bend, which mates with AC input receptacle on the Power/Distribution Shelf,
  - ◆ and on the remaining end with a NEMA L6-30P twist-lock plug.

**Restrictions**

For 208/240 VAC only (rated for 30A at 208/240VAC).

For use with List 1, 2, 5, and 6.

Each List 1 and 2 requires one (1) AC Input Cable Assembly/Line Cord.

Each List 5 and 6 requires two (2) AC Input Cable Assemblies/Line Cords.

**Ordering Notes**

- 1) Order one (1) AC Input Cable Assembly/Line Cord as required for each List 1 and 2 ordered.
- 2) Order two (2) AC Input Cable Assemblies/Line Cords as required for each List 5 and 6 ordered.

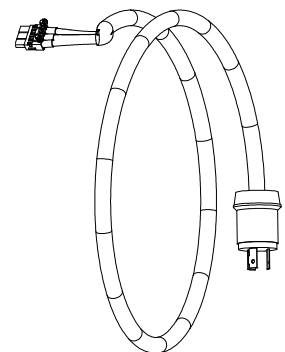

**AC Input Line Cord, 120VAC, P/N 545252**

**Features**

- ◆ Provides one (1) 14' long, 8 AWG, AC Input Line Cord;
  - ◆ terminated on one end with a Molex plug, which mates with AC input receptacle on the Power/Distribution Shelf,
  - ◆ and on the remaining end with a NEMA L5-30P twist-lock plug.

**Restrictions**

For 120 VAC only (rated for 30A at 120VAC).

For use with List 1, 2, 5, and 6.

Each List 1 and 2 requires one (1) AC Input Cable Assembly/Line Cord.

Each List 5 and 6 requires two (2) AC Input Cable Assemblies/Line Cords.

**Ordering Notes**

- 1) Order one (1) AC Input Cable Assembly/Line Cord as required for each List 1 and 2 ordered.
- 2) Order two (2) AC Input Cable Assemblies/Line Cords as required for each List 5 and 6 ordered.

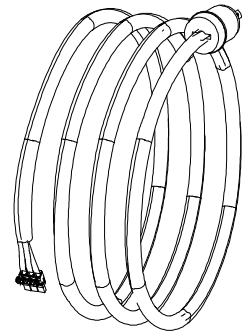

**AC Input Line Cord, 120VAC, P/N 545478**

**Features**

- ◆ Provides one (1) 14' long, 14/3 AWG, AC Input Line Cord;
  - ◆ terminated on one end with a Molex plug, which mates with AC input receptacle on the Power/Distribution Shelf,
  - ◆ and on the remaining end with a NEMA 5-15P plug.

**Restrictions**

For 120 VAC only (rated for 15A at 120VAC).

For use with List 1 and 5 equipped with R48-500 rectifier modules.

Each List 1 requires one (1) AC Input Cable Assembly/Line Cord.

Each List 5 requires two (2) AC Input Cable Assemblies/Line Cords.

**Ordering Notes**

- 1) Order one (1) AC Input Cable Assembly/Line Cord as required for each List 1 ordered.
- 2) Order two (2) AC Input Cable Assemblies/Line Cords as required for each List 5 ordered.

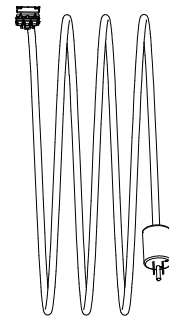

**AC Input Line Cord, 120VAC, P/N 545479**

**Features**

- ◆ Provides one (1) 14' long, 14/3 AWG, AC Input Line Cord;
  - ◆ terminated on one end with a Molex plug, which mates with AC input receptacle on the Power/Distribution Shelf,
  - ◆ and on the remaining end with a NEMA L5-15P twist-lock plug.

**Restrictions**

For 120 VAC only (rated for 15A at 120VAC).

For use with List 1 and 5 equipped with R48-500 rectifier modules.

Each List 1 requires one (1) AC Input Cable Assembly/Line Cord.

Each List 5 requires two (2) AC Input Cable Assemblies/Line Cords.

**Ordering Notes**

- 1) Order one (1) AC Input Cable Assembly/Line Cord as required for each List 1 ordered.
- 2) Order two (2) AC Input Cable Assemblies/Line Cords as required for each List 5 ordered.

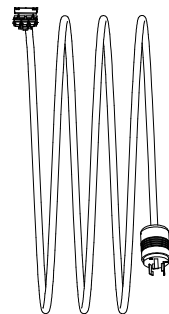

**AC Input Line Cord, 208/240VAC, P/N 545480**

**Features**

- ◆ Provides one (1) 14' long, 14/3 AWG, AC Input Line Cord;
  - ◆ terminated on one end with a Molex plug, which mates with AC input receptacle on the Power/Distribution Shelf,
  - ◆ and on the remaining end with a NEMA L6-15P twist-lock plug.

**Restrictions**

For 240 VAC only (rated for 15A at 208/240VAC).

For use with List 1 and 5.

For use with List 2 and 6 with R48-500 Rectifiers.

Each List 1 and 2 requires one (1) AC Input Cable Assembly/Line Cord.

Each List 5 and 6 requires two (2) AC Input Cable Assemblies/Line Cords.

**Ordering Notes**

- 1) Order one (1) AC Input Cable Assembly/Line Cord as required for each List 1 ordered.
- 2) Order two (2) AC Input Cable Assemblies/Line Cords as required for each List 5 ordered.

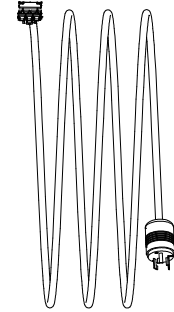

**AC Input Line Cord, 208/240VAC, P/N 545482**

**Features**

- ◆ Provides one (1) 14' long, 14/3 AWG, AC Input Line Cord;
  - ◆ terminated on one end with a Molex plug, which mates with AC input receptacle on the Power/Distribution Shelf,
  - ◆ and on the remaining end with a NEMA 6-15P plug.

**Restrictions**

For 240 VAC only (rated for 15A at 208/240VAC).

For use with List 1 and 5.

For use with List 2 and 6 with R48-500 Rectifiers.

Each List 1 and 2 requires one (1) AC Input Cable Assembly/Line Cord.

Each List 5 and 6 requires two (2) AC Input Cable Assemblies/Line Cords.

**Ordering Notes**

- 1) Order one (1) AC Input Cable Assembly/Line Cord as required for each List 1 ordered.
- 2) Order two (2) AC Input Cable Assemblies/Line Cords as required for each List 5 ordered.

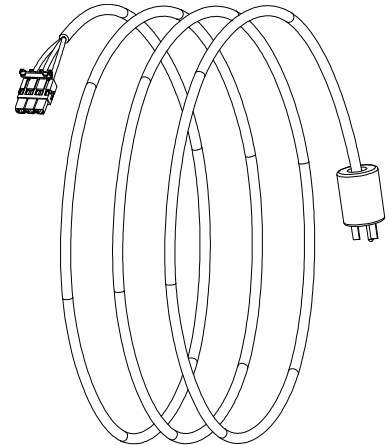

**AC Input Line Cord, 120VAC, P/N 545481**

**Features**

- ◆ Provides one (1) 14' long, 12/3 AWG, AC Input Line Cord;
  - ◆ terminated on one end with a Molex plug, which mates with AC input receptacle on the Power/Distribution Shelf,
  - ◆ and on the remaining end with a NEMA L5-20P twist-lock plug.

**Restrictions**

For 120 VAC only (rated for 20A at 120VAC).

For use with List 1 and 5.

For use with List 2 and 6 with R48-500 Rectifiers.

Each List 1 and 2 requires one (1) AC Input Cable Assembly/Line Cord.

Each List 5 and 6 requires two (2) AC Input Cable Assemblies/Line Cords.

**Ordering Notes**

- 1) Order one (1) AC Input Cable Assembly/Line Cord as required for each List 1 ordered.
- 2) Order two (2) AC Input Cable Assemblies/Line Cords as required for each List 5 ordered.

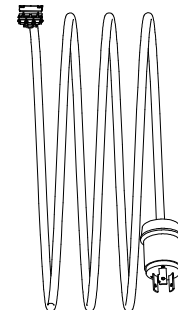



**AC Input Line Cord, 208/240VAC, P/N 545553**

**Features**

- ◆ Provides one (1) 14' long, 12/3 AWG, AC Input Line Cord;
  - ◆ terminated on one end with a Molex plug, which mates with AC input receptacle on the Power/Distribution Shelf,
  - ◆ and on the remaining end with a NEMA L6-20P twist-lock plug.

**Restrictions**

For 240 VAC only (rated for 20A at 208/240VAC).

For use with List 1, 2, 5, and 6.

Each List 1 and 2 requires one (1) AC Input Cable Assembly/Line Cord.

Each List 5 and 6 requires two (2) AC Input Cable Assemblies/Line Cords.

**Ordering Notes**

- 1) Order one (1) AC Input Cable Assembly/Line Cord as required for each List 1 and 2 ordered.
- 2) Order two (2) AC Input Cable Assemblies/Line Cords as required for each List 5 and 6 ordered.

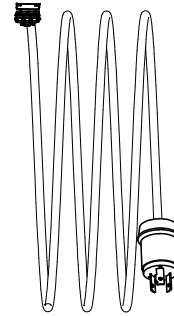

**AC Input Line Cord, 120VAC, P/N 547525**

**Features**

- ◆ Provides one (1) 14' long, 12/3 AWG, AC Input Line Cord;
  - ◆ terminated on one end with a Molex plug, which mates with AC input receptacle on the Power/Distribution Shelf,
  - ◆ and on the remaining end with a NEMA L5-30P twist-lock plug.

**Restrictions**

For 120 VAC only (rated for 30A at 120VAC).

For use with List 1, 2, 5, and 6.

Each List 1 and 2 requires one (1) AC Input Cable Assembly/Line Cord.

Each List 5 and 6 requires two (2) AC Input Cable Assemblies/Line Cords.

**Ordering Notes**

- 1) Order one (1) AC Input Cable Assembly/Line Cord as required for each List 1 and 2 ordered.
- 2) Order two (2) AC Input Cable Assemblies/Line Cords as required for each List 5 and 6 ordered.

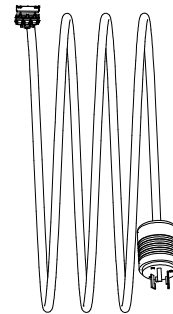

**AC Input Line Cord, 120VAC, P/N 548457**

**Features**

- ◆ Provides one (1) 6' long, 14/3 AWG, AC Input Line Cord;
  - ◆ terminated on one end with a Molex plug, which mates with AC input receptacle on the Power/Distribution Shelf,
  - ◆ and on the remaining end with a NEMA 5-15P plug.

**Restrictions**

For 120 VAC only (rated for 15A at 120VAC).

For use with List 1 and 5 with R48-500 Rectifiers.

Each List 1 requires one (1) AC Input Cable Assembly/Line Cord.

Each List 5 requires two (2) AC Input Cable Assemblies/Line Cords.

**Ordering Notes**

- 1) Order one (1) AC Input Cable Assembly/Line Cord as required for each List 1 ordered.
- 2) Order two (2) AC Input Cable Assemblies/Line Cords as required for each List 5 ordered.

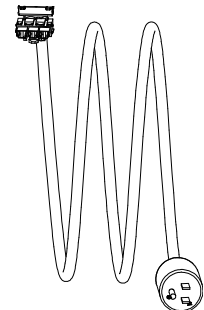

**AC Input Line Cord, 120/208/240VAC, P/N 548196**

**Features**

- ◆ Provides one (1) 6' long, 12/3 AWG, AC Input Line Cord;
  - ◆ terminated on one end with a Molex plug, which mates with AC input receptacle on the Power/Distribution Shelf,
  - ◆ and on the remaining end with an IEC320 C20 plug.

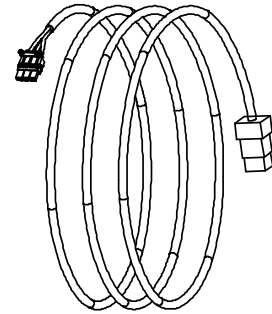

**Restrictions**

For 120/208/240 VAC (rated for 20A at 120/208/240VAC).

For 208/240V use with List 1, 2, 5, and 6 and all rectifier modules.

For 120V use with List 1 and 5 and all rectifier modules.

For 120V use with List 2 and 6 with 500W rectifier module only.

Each List 1 and 2 requires one (1) AC Input Cable Assembly/Line Cord.

Each List 5 and 6 requires two (2) AC Input Cable Assemblies/Line Cords.

Per UL 60950-1, 2nd Edition, when this cord is used with this power system, the following restrictions apply:

- The power system must be used in a location having equipotential bonding (such as a telecommunications centre, a dedicated computer room or a restricted access location).
- The building installation shall provide a means for connection to protective earth; and
- The equipment is to be connected to that means; and
- A service person shall check whether or not the socket-outlet from which the equipment is to be powered provides a connection to the building protective earth. If not, the service person shall arrange for the installation of a protective earthing conductor from the separated protective earthing terminal to the protective earth wire in the building.

**Ordering Notes**

- 1) Order one (1) AC Input Cable Assembly/Line Cord as required for each List 1 and 2 ordered.
- 2) Order two (2) AC Input Cable Assemblies/Line Cords as required for each List 5 and 6 ordered.

**AC Input Line Cord, 120VAC, P/N 10015356**

**Features**

- ◆ Provides one (1) 6' long, 12/3 AWG, AC Input Line Cord;
  - ◆ terminated on one end with a Molex plug, which mates with AC input receptacle on the Power/Distribution Shelf,
  - ◆ and on the remaining end with a NEMA 5-20P plug.

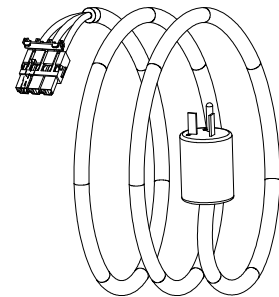

**Restrictions**

For 120 VAC only (rated for 20A at 120VAC).

For use with List 1 and 5 with R48-1000 Rectifiers.

Each List 1 requires one (1) AC Input Cable Assembly/Line Cord.

Each List 5 requires two (2) AC Input Cable Assemblies/Line Cords.

**Ordering Notes**

- 1) Order one (1) AC Input Cable Assembly/Line Cord as required for each List 1 ordered.
- 2) Order two (2) AC Input Cable Assemblies/Line Cords as required for each List 5 ordered.

### **AC Input Line Cord, 120VAC, P/N 10015358**

#### **Features**

- ◆ Provides one (1) 6' long, 12/3 AWG, AC Input Line Cord;
  - ◆ terminated on one end with a Molex plug, which mates with AC input receptacle on the Power/Distribution Shelf,
  - ◆ and on the remaining end with a NEMA L5-30P twist-lock plug.

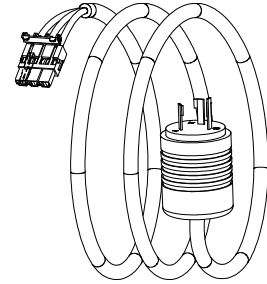

#### **Restrictions**

For 120 VAC only (rated for 30A at 120VAC).

For use with List 1, 2, 5, and 6.

Each List 1 and 2 requires one (1) AC Input Cable Assembly/Line Cord.

Each List 5 and 6 requires two (2) AC Input Cable Assemblies/Line Cords.

#### **Ordering Notes**

- 1) Order one (1) AC Input Cable Assembly/Line Cord as required for each List 1 and 2 ordered.
- 2) Order two (2) AC Input Cable Assemblies/Line Cords as required for each List 5 and 6 ordered.

### **Special Application Digital Input Cable Kit, P/N 554935**

#### **Features**

- ◆ Provides an alarm cable kit to add -48VDC to digital input #2.
- ◆ The kit consists of two pieces that plug together to make a complete connection. One part is pre-wired to the shelf and the other part is shipped loose.

#### **Restrictions**

For use with List 1 and 2.

#### **Ordering Notes**

- 1) Order one (1) Special Application Digital Input Cable Kit as required for each List 1 and 2 ordered.

### Vertiv™ NetSure™ 211bc Battery Cabinet (Spec. No. 541434)

#### Features

- ◆ The Vertiv™ NetSure™ 211bc Battery Cabinet is rated at 30 amperes, and can be mounted in a 19" or 23" nominal relay rack, or mounted to a suitable wall.
- ◆ The Battery Cabinet contains one (1) 40 ampere battery disconnect circuit breaker.
- ◆ Battery circuit breaker alarm leads are provided to tie into the power system's alarm circuit.
- ◆ The Battery Cabinet is equipped with a battery cable terminated in an Anderson connector.
- ◆ Cables to connect the batteries (as specified in the table under *Order Notes*) into the Battery Cabinet provided.
- ◆ Battery Cabinets can be paralleled to provide greater reserve time. Battery cabinets contain a second Anderson battery connector for plugging one cabinet into another.

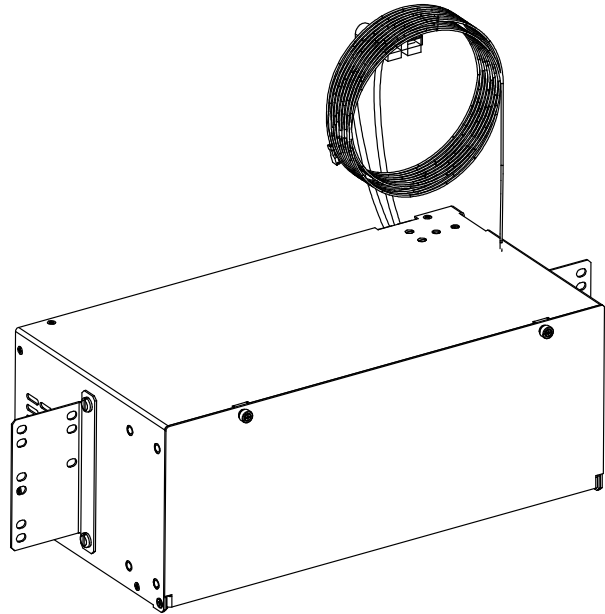

#### Ordering Notes

- 1) Order by Spec. No. 541434 as required.
- 2) Also order four (4) batteries per Battery Cabinet per the following table.

Battery Manufacturer	Manufacturer P/N	Vertiv P/N	Capacity Amp-Hours (8Hr rate)	Weight (lb) per Battery
Hawker	SBS 15	139091	14	12.50
Fiamm	12SLA12	139092	12	12.35
Energys	NP18-12FR	139774	16 *	13.60

\* 10Hr rate

- 3) When ordering 139774 batteries, also order 545427 Battery Connection kit.
- 4) When wall mounted, also order a battery cabinet frame grounding landing point adapter P/N 556872. This adapter installs in the relay rack mounting bracket holes located on either side of the cabinet.

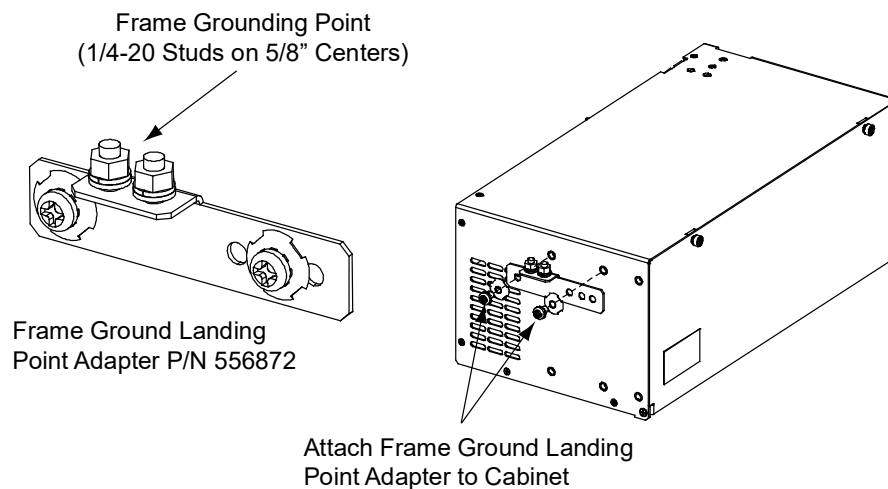

**Vertiv™ NetSure™ 211bc Battery Cabinet (Spec. No. 545534)**

**Features**

- ◆ The Vertiv™ NetSure™ 211bc Battery Cabinet is rated at 30 amperes, and can be mounted in a 19" or 23" nominal relay rack, or mounted to a suitable wall.
- ◆ The Battery Cabinet contains one (1) 40 ampere battery disconnect circuit breaker.
- ◆ Battery circuit breaker alarm leads are provided to tie into the power system's alarm circuit.
- ◆ The Battery Cabinet is equipped with a battery cable terminated in an Anderson connector.
- ◆ Cables to connect the batteries (as specified in the table under *Ordering Notes*) into the Battery Cabinet provided.
- ◆ Battery Cabinets can be paralleled to provide greater reserve time. Battery cabinets contain a second Anderson battery connector for plugging one cabinet into another.

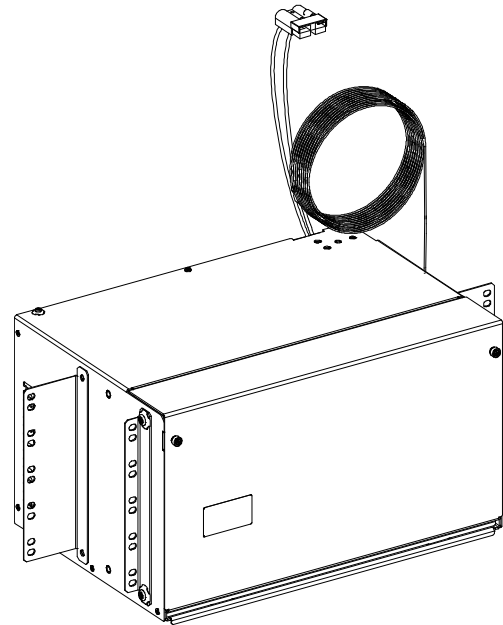

**Ordering Notes**

- 1) Order by Spec. No. 545534 as required.
- 2) Also order four (4) batteries per Battery Cabinet per the following table.

Battery Manufacturer	Manufacturer P/N	Vertiv P/N	Capacity Amp-Hours (8Hr rate)	Weight (lb) per Battery
Energys	SBS B10	140553	38	28.20
C&D / Dynasty	TEL12-30	140455	30.5	26.70
Energys	SBS30	-	26	20.9
Energys	SBS40	140581	38	28

- 3) When wall mounted, also order a battery cabinet frame grounding landing point adapter P/N 556872. This adapter installs in the relay rack mounting bracket holes located on either side of the cabinet.

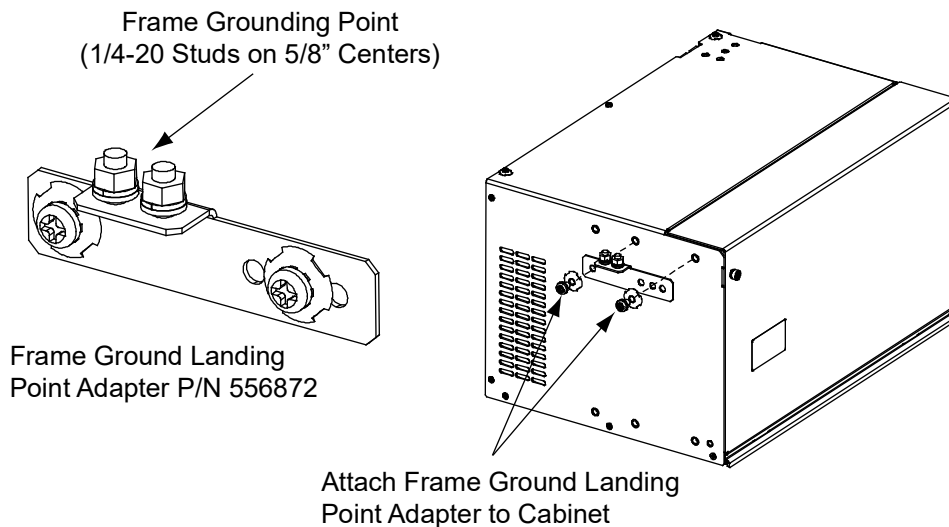

### Vertiv™ NetSure™ 211bc Battery Cabinet (Spec. No. 545506)

#### Features

- ◆ The Vertiv™ NetSure™ 211bc Battery Cabinet is rated at 30 amperes, and can be mounted in a 23" nominal relay rack, or mounted to a suitable wall.
- ◆ The Battery Cabinet contains one (1) 40 ampere battery disconnect circuit breaker.
- ◆ Battery circuit breaker alarm leads are provided to tie into the power system's alarm circuit.
- ◆ The Battery Cabinet is equipped with a battery cable terminated in an Anderson connector.
- ◆ Cables to connect the batteries (as specified in the table under *Ordering Notes*) into the Battery Cabinet provided.
- ◆ Battery Cabinets can be paralleled to provide greater reserve time. Battery cabinets contain a second Anderson battery connector for plugging one cabinet into another.

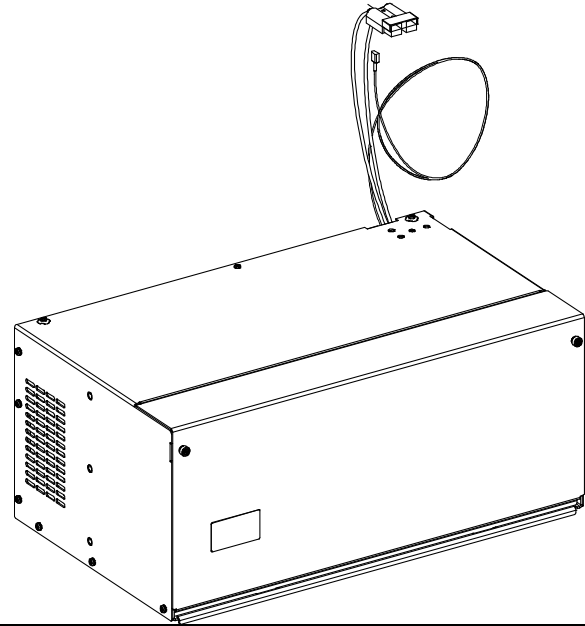

#### Ordering Notes

- 1) Order by Spec. No. 545506 as required.
- 2) Also order four (4) batteries per Battery Cabinet per the following table.

Battery Manufacturer	Manufacturer P/N	Vertiv P/N	Capacity Amp-Hours (8Hr rate)	Weight (lb) per Battery
Energys	SBS B10	140553	38	28.20
Energys	SBS 40	140581	38	28.00
C&D/ Dynasty	TEL12-30	140455	30.5	26.70
C&D/ Dynasty	TEL12-45	140454	46	26.70

- 3) When wall mounted, also order a battery cabinet frame grounding landing point adapter P/N 556872. This adapter installs in the relay rack mounting bracket holes located on either side of the cabinet.

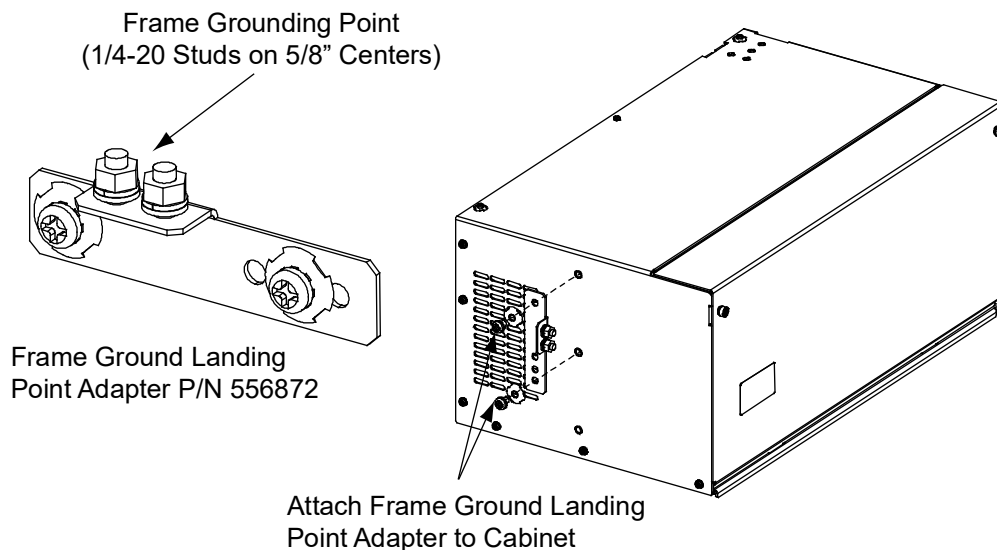

## SM TEMP Temperature Concentrator (P/N 547490)

### Features

- ◆ Allows for multiple temperature probes to be used for temperature compensation. Compensation can be based on highest probe temperature or average probe temperature.
- ◆ Provides (8) temperature probe inputs per SM TEMP.
- ◆ Can be cascaded up to (8) SM TEMP modules, connecting up to 64 temperature probes.
- ◆ Provides analog output for all controllers.

### Restrictions

Concentrator needs to plug into analog temp input on IB2 board.

### Ordering Notes

- 1) Order P/N 547490.
- 2) Order up to (8) 3 meter (P/N 556155) or 10 meter (P/N 552992) temperature probes for each concentrator.

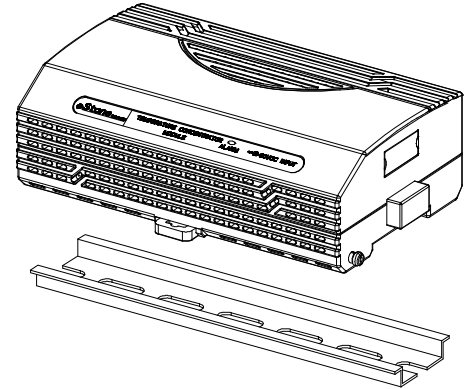

## SM Module RS-485 Interface Cable P/N 547674

### Features

- ◆ Provides 4' cable for connecting SM supervisory modules to the system RS-485 SB interface connector.
- ◆ For interface with SM AC, SM BAT, SM BRC, or SM IO modules.

### Restrictions

One (1) RS-485 connector is available in the system.

### Ordering Notes

- 1) Order P/N 547674 as required.

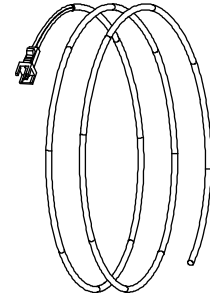

## PCU Blank Filler Panel, P/N PSK4820R-1

### Features

- ◆ Provides 1x2U blank filler panel for rectifier module.

### Ordering Notes

- 1) Order P/N PSK4820R-1 as required.

## Anderson Battery Connector

### Features

- ◆ Includes the components necessary to assemble an Anderson connector onto a battery cable.

### Restrictions

Appropriate battery post mating lugs must be ordered separately.

### Ordering Notes

Order Anderson connector housings and lugs per the following table.

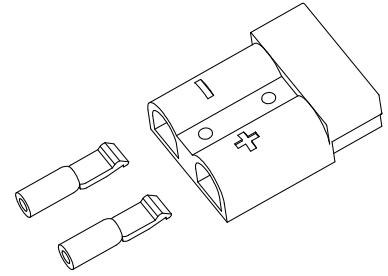

Single Part Number for a Housing and Lugs		
Description	Vertiv P/N	Anderson P/N
<p>For a single string (spare for List 71). Consists of two (2) lugs (Anderson P/N 5952) and one (1) Red Connector (Anderson P/N 992G1). Lugs accept 8 AWG wire. Allows for the connection of one (1) battery string (both polarities) (one wire per lug).</p> <p>For a single string (spare for List 73). Consists of two (2) lugs (Anderson P/N 5900) and one (1) Red Connector (Anderson P/N 992G1). Lugs accept 6 AWG wire. Allows for the connection of one (1) battery string (both polarities) (one wire per lug).</p>	(not available in kit form, order components individually per the second half of this table)	(not available in kit form, order components individually per the second half of this table)
<p>For a double string (spare for List 72). Consists of two (2) lugs (Anderson P/N 5900) and one (1) Red Connector (Anderson P/N 992G1). Lugs accept 6 AWG wires. Allows for the connection of two (2) battery strings (both polarities) (two [10 AWG] wires per lug).</p>	133196	6331G1
Individual Housing and Lugs Part Numbers (spare for List 1, 2, 71, and 73)		
Description	Vertiv P/N	Anderson P/N
Housing	138922	992G1
Lug (accepts 8 AWG wire) (2 required per housing)	247109602	5952
Lug (accepts 6 AWG wire) (2 required per housing)	111691	5900



## Digital Input and Relay Output Cables

### Features

- ◆ **Lists 1 and 2:** Two sets of customer wiring cables are available. One set is for Digital Inputs and Relay outputs. The other set is for an additional -48V digital input. One half of the Digital Inputs and Relay Outputs cable is provided and factory connected in the shelf. The other half (includes mating connector on one end and un-terminated on the other end) must be ordered separately. The additional -48V digital input cable must be ordered separately. When ordered, one half of the -48V digital input cable is factory connected in the shelf. The other half has a mating connector on one end and is un-terminated on the other end.
- ◆ **Lists 5 and 6:** Two sets of customer wiring cables are available. One set is for the Digital Inputs and another set, for the Relay Outputs. One half of the Relay Outputs Cable is provided and factory connected in the shelf. The other half (includes mating connector on one end and un-terminated on the other end) must be ordered separately. Both halves of the Digital Inputs Cable must be ordered separately. When ordered, one half of the Digital Inputs Cable is factory connected in the shelf. The other half has a mating connector on one end and is un-terminated on the other end.

### Ordering Notes

- 1) **Lists 1 and 2:** For the Digital Inputs and Relay Outputs Cable, P/N 545494 (2 ft.) is provided and factory connected in the List 1 and 2 shelves. The mating cable, P/N 545495 (10 ft.) must be ordered separately.  
For additional -48V Digital Input Cable Kit, order P/N 554935.
- 2) **Lists 5 and 6:** For the Relay Outputs Cable, P/N 541308 (3 ft.) is provided and factory connected in the List 5 and 6 shelves. A mating cable, P/N 541309 (10 ft.) or P/N 545644 (50 ft.), must be ordered separately.  
For the Digital Inputs Cable, order P/N 541310 (shelf side, 3 ft.) and P/N 541311 (customer side, 10 ft.).

**Note:** A custom digital input cable and internal wiring kit is available, P/N 545594. This kit is factory installed only.

## User Replaceable Components

### Ordering Notes

- 1) Refer to Table 4.

Item	Part Number
500W Rectifier Module	1R48500
1000W Rectifier Module	1R481000
Rectifier Blank Panel	PSK4820R-1
Rectifier Module Fan	32010093
NCU Controller Module	1M830BNA* * Also specify the appropriate NCU configuration file. Refer to the configuration file label on your existing NCU Controller.
Temperature Probe	Order per List 90 (9 ft. long) or List 91 (30 ft. long) (or if only one piece of the two piece probe is needed, see the List 90 or 91 description for part numbers). See "Optional Temperature Probes" on page 38 for temperature probe options with a mounting tab.

Table 4  
Replacement Module Part Numbers

## Wiring Notes

Refer also to the next section, [Wiring Illustrations](#).

### Shelf Frame Grounding Stud

#### Features

- ◆ An M5 frame grounding stud with hardware is provided on the rear of the shelf.

#### Restrictions

Recommended frame ground wire size is 6 AWG.

### AC Input Branch Circuit Protection and Wiring

#### Features

- ◆ Each shelf contains one (1) or two (2) side mounted plug-in AC input connector(s).
- ◆ AC Input Cable Assemblies/Line Cords are available that plug into the shelf's AC input connector.

#### Restrictions

Lists 1 and 2 require one (1) AC input branch circuit.

The AC input branch circuit feeds two (2) (List 1) or three (3) (List 2) rectifiers.

Refer to the following table for recommended branch circuit protection.

Lists 5 and 6 require two (2) AC input branch circuits.

Each AC input branch circuit feeds two (2) (List 5) or three (3) (List 6) rectifiers.

Refer to the following table for recommended branch circuit protection.

AC Input Branch Circuit Protection*				
System	208/240VAC Input		120VAC Input	
	500W Rect.	1000W Rect.	500W Rect.	1000W Rect.
58213660001 58213660005 (2-Rectifiers per AC Feed)	15A	15A	15A	20A
58213660002 58213660006 (3-Rectifiers per AC Feed)	15A	20A	20A	25A / 30A

\* Protective devices should be of the time-delay or high inrush type.

For correct AC input wire size, use the appropriate AC Input Cable Assembly/Line Cord for each AC input branch circuit. Refer to *AC Input Cables and Line Cords* in the ACCESSORY DESCRIPTIONS section of this document.

### External Alarm and Monitoring Wiring

#### Features

- ◆ **List 5 and 6:** Relay output and digital input leads are connected to screw-type terminal blocks located on the Customer Interface Board mounted inside the shelf. One half of a Relay Outputs Cable is factory connected to these terminals. The other half (includes mating connector on one end and un-terminated on the other end) is ordered separately. If ordered, one half of a Digital Input Cable is factory connected to these terminals. The other half includes a mating connector on one end and is un-terminated on the other end.
- ◆ **List 1 and 2:** Relay output and digital input leads are connected to screw-type terminals located on the SCU+ or NCU Controller Module mounted inside the shelf. One half of a Digital Input/Relay Output Cable is factory connected to these terminals. The other half (includes mating connector on one end and un-terminated on the other end) is ordered separately.

If an additional -48V Digital Input cable is ordered, one half of the cable is factory connected in the shelf. The other half includes mating connector on one end and is un-terminated on the other end. The additional -48V digital input cable must be ordered separately.

#### Restrictions

Recommended Wire Size: 22 AWG for Loop Lengths Up to 200 ft.  
18-20 AWG for Loop Lengths Over 200 ft.

### **Load Distribution Wiring (GMT Fuses) (Lists BG and NG only)**

#### **Features**

- ◆ Load and load return leads are connected to a screw-type terminal block located on the front of the Distribution Unit.

#### **Restrictions**

The rating of the distribution device determines the wire size requirements. Refer to the American National Standards Institute (ANSI) approved National Fire Protection Association's (NFPA), National Electrical Code (NEC) and applicable local codes.

Terminal block wire size capacity is 20 to 12 AWG.

### **Load Distribution Wiring (GMT Fuses) (Lists BF and NF only)**

#### **Features**

- ◆ Load distribution (GMT fuses) and load return leads are connected to receptacles located inside the Distribution Unit. Load leads are brought into the right side (as viewed from the front) of the shelf and are accessible from the front of the shelf. Note that the GMT distribution fuse block accepts two ranges of fuse amperage sizes, and that two different types of receptacles are provided.

#### **Restrictions**

The rating of the distribution device determines the wire size requirements. Refer to the American National Standards Institute (ANSI) approved National Fire Protection Association's (NFPA), National Electrical Code (NEC) and applicable local codes.

#### **Ordering Notes**

- 1) Lists 61 provides 12' long, 16 AWG, load and load return leads that are terminated on one end with the appropriate mating connector\* to plug into the system's lower amperage rating GMT fuse connector, and are left un-terminated at the remaining end for connection into customer loads.
  - \* Consists of housing Molex P/N 39-01-2025 and terminals P/N 44476-3112 [loose] or 44476-3111 [reel].
- 2) Lists 62 provides 12' long, 14 AWG, load and load return leads that are terminated on one end with the appropriate mating connector\* to plug into the system's higher amperage rating GMT fuse connector, and are left un-terminated at the remaining end for connection into customer loads.
  - \* Consists of housing Tyco P/N 350777-1 and terminals Tyco P/N 350551-3 [loose] or Tyco 350537-3 [reel].

### **Load Distribution Wiring (GMT Fuses) (Lists BC, NC, BA, and NA)**

#### **Features**

- ◆ Load distribution (GMT fuses) and load return leads are connected to receptacles located inside the Distribution Unit. Load leads are brought into the right side (as viewed from the front) of the shelf and are accessible from the front of the shelf.

#### **Restrictions**

The rating of the distribution device determines the wire size requirements. Refer to the American National Standards Institute (ANSI) approved National Fire Protection Association's (NFPA), National Electrical Code (NEC) and applicable local codes.

#### **Ordering Notes**

- 1) List 60 provides 12' long, 16 AWG, load and load return leads that are terminated on one end with the appropriate mating connector\* to plug into the system's GMT fuse connector, and are left un-terminated at the remaining end for connection into customer loads.
  - \* Consists of housing Molex P/N 39-01-2025 and terminals P/N 44476-3112 [loose] or 44476-3111 [reel].

### **Load Distribution Wiring (Optional Bullet-Nose-Type 6-Position GMT Fuse Module)**

#### **Features**

- ◆ Load and load return leads are connected to a screw-type terminal block located on the front of the Fuse Module.

#### **Restrictions**

The rating of the distribution device determines the wire size requirements. Refer to the American National Standards Institute (ANSI) approved National Fire Protection Association's (NFPA), National Electrical Code (NEC) and applicable local codes.

Terminal block wire size capacity is 24 to 14 AWG.

### **Load Distribution Wiring (Circuit Breakers) (Lists BC, NC, BA, and NA)**

#### **Features**

- ◆ Load distribution (circuit breakers) and load return leads terminated in two-hole lugs are connected to threaded studs located inside the Distribution Unit. Load leads are brought into the right side (as viewed from the front) of the shelf and are accessible from the front of the shelf.

#### **Restrictions**

The rating of the distribution device determines the wire size requirements. Refer to the American National Standards Institute (ANSI) approved National Fire Protection Association's (NFPA), National Electrical Code (NEC) and applicable local codes.

All lugs for customer connections must be ordered separately. Mounting hardware is factory supplied.

Maximum wire size is 6 AWG when all four (4) circuit breaker positions are used. 4 AWG or 2 AWG can be used, but the number of breaker positions will be reduced as follows;

- **4 AWG:** Three (3) breakers max. (2 load/1 battery or 1 load/2 battery on lists BA and NA; 3 load on lists BC and NC). Use 6 AWG for CO Ground.
- **2 AWG:** Two (2) breakers max. (1 load/1 battery on lists BA and NA; 2 load on lists BC and NC). Use 6 AWG for CO Ground.

For 4 AWG and 2 AWG wire, install a customer supplied flat washer between the lug and the nut supplied on the termination.

#### **Ordering Notes**

- 1) The rating of the distribution device determines the wire size requirements. For wire size and lug selection, refer to Table 5.
- 2) Lugs should be crimped per lug manufacturer's specifications.

Circuit Breaker Amperage	Recm 90°C Wire Size <sup>(1)</sup>						
	14 AWG	12 AWG	10 AWG	8 AWG	6 AWG	4 AWG	2 AWG
	Loop Length (feet) <sup>(2)</sup>						
1, 3, 5, 10A	37 <sup>(3, 4, 5)</sup>	58 <sup>(3, 4, 5)</sup>	93 <sup>(3, 4, 5)</sup>	148 <sup>(3, 4, 5)</sup>	236 <sup>(3, 4, 5)</sup>	--	--
15A	24 <sup>(3, 4)</sup>	39 <sup>(3, 4, 5)</sup>	62 <sup>(3, 4, 5)</sup>	99 <sup>(3, 4, 5)</sup>	157 <sup>(3, 4, 5)</sup>	--	--
20A	--	29 <sup>(3, 4)</sup>	46 <sup>(3, 4, 5)</sup>	74 <sup>(3, 4, 5)</sup>	118 <sup>(3, 4, 5)</sup>	--	--
25A	--	--	37 <sup>(3, 4)</sup>	59 <sup>(3, 4, 5)</sup>	94 <sup>(3, 4, 5)</sup>	--	--
30A	--	--	31 <sup>(3, 4)</sup>	49 <sup>(3, 4, 5)</sup>	78 <sup>(3, 4, 5)</sup>	--	--
35A	--	--	--	42 <sup>(3, 4)</sup>	67 <sup>(3, 4, 5)</sup>	107 <sup>(3, 4)</sup>	--
40A	--	--	--	37 <sup>(3, 4)</sup>	59 <sup>(3, 4, 5)</sup>	94 <sup>(3, 4)</sup>	--
45A	--	--	--	33 <sup>(3, 4)</sup>	52 <sup>(3, 4)</sup>	83 <sup>(3, 4)</sup>	--
50A	--	--	--	29 <sup>(3)</sup>	47 <sup>(3, 4)</sup>	75 <sup>(3, 4)</sup>	--
60A	--	--	--	--	39 <sup>(3, 4)</sup>	62 <sup>(3, 4)</sup>	99 <sup>(3, 4)</sup>
70A						53 <sup>(3, 4)</sup>	85 <sup>(3, 4)</sup>
75A						50 <sup>(3, 4)</sup>	79 <sup>(3, 4)</sup>
80A						47 <sup>(3, 4)</sup>	74 <sup>(3, 4)</sup>
90A						41 <sup>(3)</sup>	66 <sup>(3, 4)</sup>
100A						--	59 <sup>(3, 4)</sup>
Recommended Crimp Lug <sup>(6)</sup>							
2-hole	245390100	245390100	245390100	245346600	245346500	245346800	245346900

- <sup>1</sup> Wire sizes are based on recommendations of the American National Standards Institute (ANSI) approved National Fire Protection Association's (NFPA) National Electrical Code (NEC). **Table 310-16** for wire rated at 90°C conductor temperature operating in ambient temperatures of 40°C, 50°C, and 65°C was used. For other operating ambient temperatures, refer to the NEC. For operation in countries where the NEC is not recognized, follow applicable codes.
- <sup>2</sup> Recommended wire sizes are sufficient to restrict voltage drop to 1.0 volt or less at listed branch current for the loop lengths shown. Loop length is the sum of the lengths of the positive and negative leads.
- <sup>3</sup> Wire Size / Loop Length Combination Calculated using 40°C Ambient Operating Temperature.
- <sup>4</sup> Wire Size / Loop Length Combination Calculated using 50°C Ambient Operating Temperature.
- <sup>5</sup> Wire Size / Loop Length Combination Calculated using 65°C Ambient Operating Temperature.
- <sup>6</sup> Two-hole lugs are 10-32 bolt clearance on 5/8" centers. Lugs should be crimped per lug manufacturer's specifications.

Table 5  
Recommended Battery and Load Distribution Wire Size and Lug Selection  
(Bullet Nose-Type Circuit Breaker)

### **Load Distribution Wiring (GMT Fuses) (List KG)**

#### **Features**

- ◆ Load distribution (GMT fuses) and load return leads are connected to terminal blocks located on the front of the assembly.

#### **Restrictions**

The rating of the distribution device determines the wire size requirements. Refer to the American National Standards Institute (ANSI) approved National Fire Protection Association's (NFPA), National Electrical Code (NEC) and applicable local codes.

Terminal block wire size capacity is 26 to 14 AWG.

### **CO Ground Wiring (Lists BF, NF, BC, NC, BA, and NA)**

#### **Features**

- ◆ Two 10-32 studs on 5/8" centers with hardware are provided on the Return Bus for CO Ground wiring.

#### **Restrictions**

Recommended CO ground wire size is 6 AWG.

Recommended lug is 245346500 (2-hole, 10-32 clearance holes, 5/8" centers).

### **Input Battery Wiring (List BG and NG)**

#### **Features**

- ◆ Two (2) 8 AWG 48" long battery cables are factory connected inside the shelf. These cables are terminated at the customer end in a Red SB50 Anderson battery connector. A mating Anderson battery connector is provided [Housing: Vertiv P/N 138922, Anderson Power Products P/N 992G1. Contacts (two provided): Vertiv P/N 247109602, Anderson Power Products P/N 5952].
- ◆ Additional strings of battery may be connected to the system using the available battery cable kits (see List 71 and List 72).

#### **Restrictions**

Battery leads are NOT internally fused.

### **Input Battery Wiring (to Battery Disconnect Circuit Breakers) (Lists BA and NA)**

#### **Features**

- ◆ Battery and battery return leads terminated in two-hole lugs are connected to threaded studs located inside the Distribution Unit. Battery leads are brought into the right side (as viewed from the front) of the shelf and are accessible from the front of the shelf.

#### **Restrictions**

The rating of the distribution device determines the wire size requirements. Refer to the American National Standards Institute (ANSI) approved National Fire Protection Association's (NFPA) National Electrical Code (NEC) and applicable local codes.

All lugs for customer connections must be ordered separately. Mounting hardware is factory supplied.

Maximum wire size is 6 AWG when all four (4) circuit breaker positions are used. 4 AWG or 2 AWG can be used, but the number of breaker positions will be reduced as follows;

- **4 AWG:** Three (3) breakers max. (2 load/1 battery or 1 load/2 battery on lists BA and NA; 3 load on lists BC and NC). Use 6 AWG for CO Ground.
- **2 AWG:** Two (2) breakers max. (1 load/1 battery on lists BA and NA; 2 load on lists BC and NC). Use 6 AWG for CO Ground.

For 4 AWG and 2 AWG wire, install a customer supplied flat washer between the lug and the nut supplied on the termination.

#### **Ordering Notes**

- 1) The rating of the distribution device determines the wire size requirements. For wire size and lug selection, refer to Table 5.
- 2) Lugs should be crimped per lug manufacturer's specifications.

**Input Battery Wiring (to Battery Busbars) (Lists BF, NF, BC, and NC)**

**Features**

- ◆ Battery and battery return leads terminated in two-hole lugs are connected to threaded studs located inside the Distribution Unit. Battery leads are brought into the right side (as viewed from the front) of the shelf and are accessible from the front of the shelf.

**Restrictions**

All lugs for customer connections must be ordered separately. Mounting hardware is factory supplied.

Maximum size of wire to be connected to a single lug position is 2 AWG.

Maximum lug width, 0.61".

**Ordering Notes**

- 1) Battery wire size varies depending on load, therefore no specific information is provided for wire size. When making connections, observe correct polarity.
- 2) List 65 and List 66 provide 2 AWG “shelf side” and “battery side” (respectively) battery cables.

## Wiring Illustrations

### Shelf Frame Grounding Stud

List 1  
(List 2 Similar)

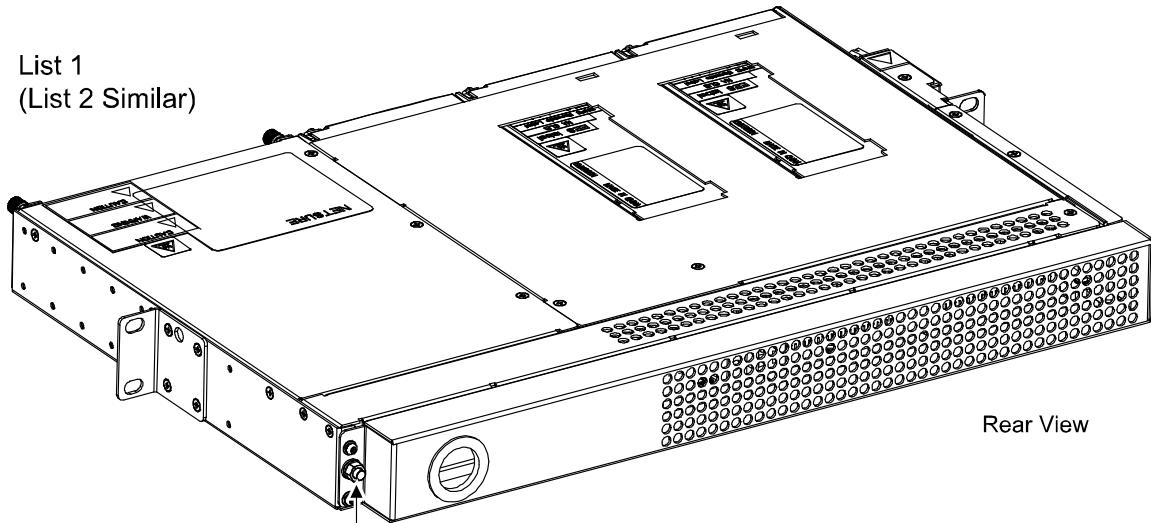

Rear View

For List 1 with Rear AC  
Input Connection (not shown),  
a 10-32 stud is used.

Connect a frame grounding  
lead to this stud, if required.

Stud is a size M5 for all Lists with  
Side AC Input Connection.

List 5  
(List 6 Similar)

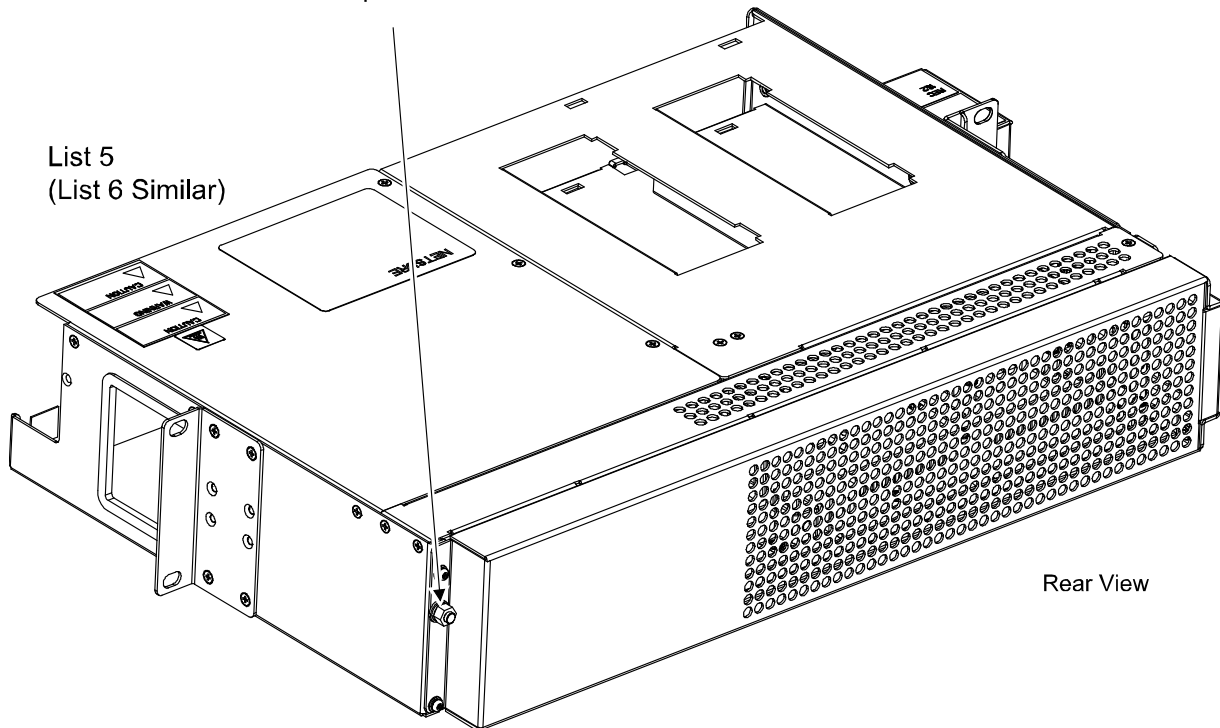

Rear View



**AC Input Wiring (Lists 1 and 2)**

List 1 and List 2 with Side AC Input Connectors  
(List 1 shown)

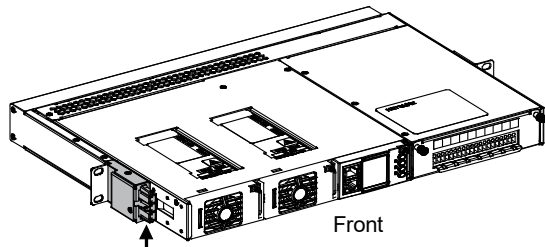

AC input connections are made using the supplied AC input cable assemblies/line cords connected here.

List 1 with Rear AC Input Connectors

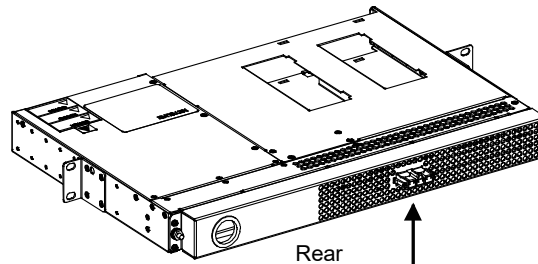

AC input connections are made using the supplied AC input cable assemblies/line cords connected here.

\* Rectifiers are numbered left to right as viewed from the front.

Front View

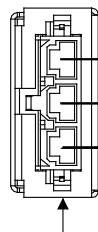

Nominal 120/208/240V  
AC Input for Rectifier Module:  
List 1 (19" Shelf): #1 and #2  
List 2 (23" Shelf): #1, #2, and #3

**AC Input Cable Assembly      AC Input Line Cord**

L2-N — Blue\* — White\*  
Ground — Green/Yellow\* — Green\*  
L1 — Brown\* — Black\*

\* color of AC Input Cable Assembly/Line Cord lead.

Rear View

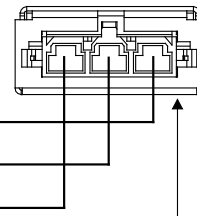

Nominal 120/208/240V  
AC Input for Rectifier Module:  
List 1 (19" Shelf): #1 and #2

ENSURE THE PROPER VOLTAGE AC BRANCH CIRCUIT AND LINE CORDS WITH THE APPROPRIATE PLUG ARE USED FOR YOUR APPLICATION.

500W Rectifier: 120/208/240 VAC Input  
1000W Rectifier: 120/208/240 VAC Input

**“WARNING - HIGH LEAKAGE CURRENT.”**  
An industrial style plug is required when providing power to three (3) or more Rectifier Modules with a flexible cord. Plug and outlet types 1-15, 2-15, 2-20, 5-15, and 5-20 as specified in IEC 60083 are considered to be NON-INDUSTRIAL within the meaning of this standard.

**\* AC Input Cable Assembly / Line Cords**

Part Number	Customer End	
535232	unterminated	(List 1 & 2)
540946	L6-30P	(List 1 & 2)
545252	L5-30P	(List 1 & 2)
545478	5-15P	(List 1 w/ R48-500)
545479	L5-15P	(List 1 w/ R48-500)
545480	L6-15P	(List 1; List 2 w/ R48-500)
545482	6-15P	(List 1; List 2 w/ R48-500)
545481	L5-20P	(List 1; List 2 w/ R48-500)
545553	L6-20P	(List 1 & 2)
545616	L6-30P	(List 1 & 2)
547525	L5-30P	(List 1 & 2)
548457	5-15P	(List 1 w/ R48-500)
548196	IEC320 C20	(List 1 120/208/240V & List 2 208/240 w/ R48-500 or R48-1000; List 2 120V w/ R48-500 only.)
559301	L6-30P	(List 1 & 2)
559302	L6-30P	(List 1 & 2)
559842	L6-30P	(List 1 & 2)
10015356	5-20P	(List 1 w/ R48-1000)
10015358	L5-30P	(List 1 & 2)

**AC Input Wiring (Lists 5 and 6)**

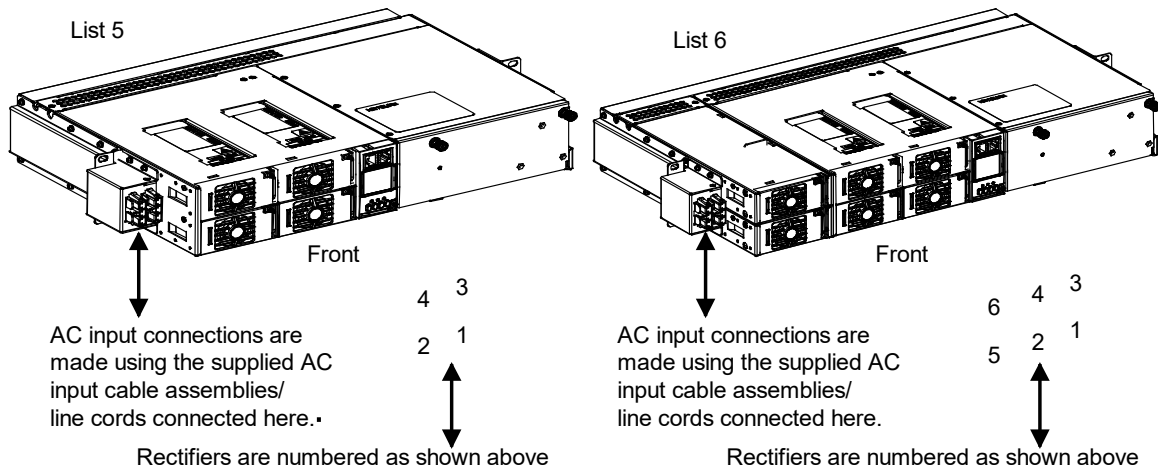

ENSURE THE PROPER VOLTAGE AC BRANCH CIRCUIT AND LINE CORDS WITH THE APPROPRIATE PLUG ARE USED FOR YOUR APPLICATION.

500W Rectifier: 120/208/240 VAC Input  
1000W Rectifier: 120/208/240 VAC Input

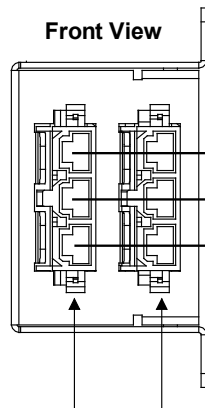

AC Input Cable Assembly	AC Input Line Cord
-------------------------	--------------------

L2-N	Blue*	White*
Ground	Green/Yellow*	Green*
L1	Brown*	Black*

\* color of AC Input Cable Assembly/Line Cord lead.

Nominal 120/208/240V  
AC Input for Rectifier Module:  
List 5 (19" Shelf): #1 and #2  
List 6 (23" Shelf): #1, #2, and #5

Nominal 120/208/240V  
AC Input for Rectifier Module:  
List 5 (19" Shelf): #3 and #4  
List 6 (23" Shelf): #3, #4, and #6

**\* AC Input Cable Assembly / Line Cords**

Part Number	Customer End	
535232	unterminated	(List 5 & 6)
540946	L6-30P	(List 5 & 6)
545252	L5-30P	(List 5 & 6)
545478	5-15P	(List 5 w/ R48-500)
545479	L5-15P	(List 5 w/ R48-500)
545480	L6-15P	(List 5; List 6 w/ R48-500)
545482	6-15P	(List 5; List 6 w/ R48-500)
545481	L5-20P	(List 5; List 6 w/ R48-500)
545553	L6-20P	(List 5 & 6)
545616	L6-30P	(List 5 & 6)
547525	L5-30P	(List 5 & 6)
548457	5-15P	(List 5 w/ R48-500)
548196	IEC320 C20	(List 5 120/208/240V & List 6 208/240 w/ R48-500 or R48-1000; List 6 120V w/ R48-500 only.)
559301	L6-30P	(List 5 & 6)
559302	L6-30P	(List 5 & 6)
559842	L6-30P	(List 5 & 6)
10015356	5-20P	(List 5 w/ R48-1000)
10015358	L5-30P	(List 5 & 6)

**“WARNING - HIGH LEAKAGE CURRENT.”**  
An industrial style plug is required when providing power to three (3) or more Rectifier Modules with a flexible cord. Plug and outlet types 1-15, 2-15, 2-20, 5-15, and 5-20 as specified in IEC 60083 are considered to be **NON-INDUSTRIAL** within the meaning of this standard.

**External Alarm and Monitoring Wiring (Lists 1 and 2)**

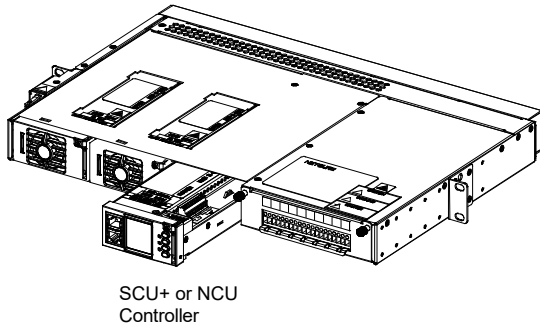

Notes

Relay Output/Digital Input Cable P/N 545494 is factory connected to terminals. Mating half (w/ unterminated ends) available, P/N 545495.

When an additional -48V Digital Input Cable Kit P/N 554935 is ordered, one half of the kit is factory connected in the shelf. The other half has a mating connector on one end and is un-terminated on the other end.

Digital Input 1 is factory wired to Load Breaker / Fuse Alarm.

Digital Input 2 default is External Battery Disconnect Circuit Breaker Alarm.

A factory-connected jumper supplies +BAT (Battery Return) to the positive side of Digital Input #2.

When ordered, Temperature Probe leads are factory connected to NCU Connector Board located in the Distribution Unit. These are labeled T1 and T2.

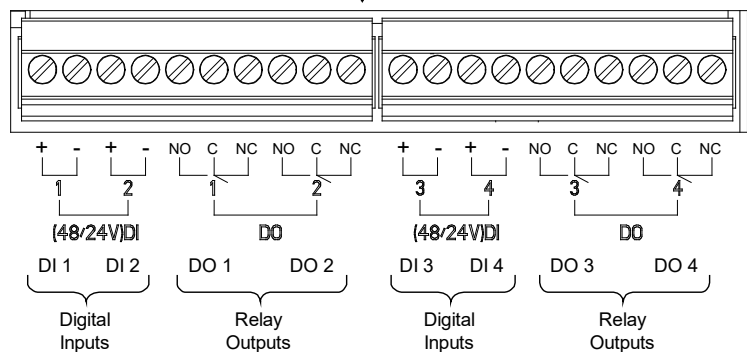
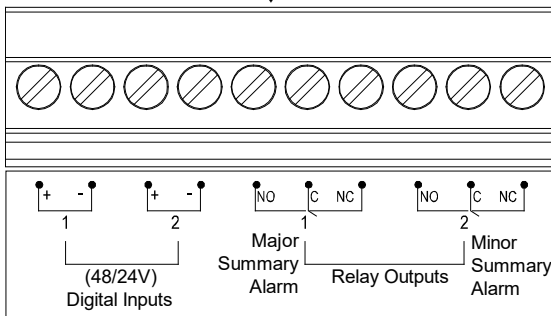
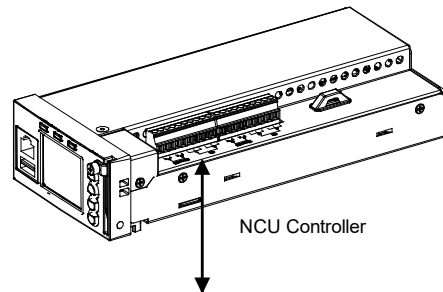
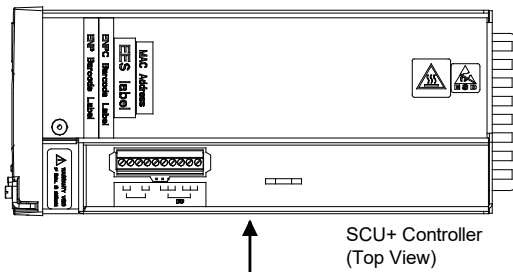

NC = Normally Closed  
COM = Common  
NO = Normally Open

All relay contacts are shown with the relay deenergized.

In the local display and Web pages, digital inputs are referred to as DI9 through DI12 and relay outputs are referred to as Relay 14 through Relay 17.

**External Alarm and Monitoring Wiring (Lists 5 and 6)**

**Note:** A custom digital input cable and internal wiring kit is available, P/N 545594. This kit is factory installed only.

Notes

Relay Output Cable P/N 541308 is factory connected to Relay Output terminals.  
Mating half (w/ unterminated ends) available, P/N 541309.

If ordered, Digital Input Cable P/N 541310 is factory connected to Digital Input terminals.  
Mating half (w/ unterminated ends) available, P/N 541311.

Digital Input 1 is factory wired to Load Breaker / Fuse Alarm.  
Digital Input 2 is reserved for External Battery Breaker Alarm.  
A factory connected jumper supplies +BAT (Battery Return) to the positive side of Digital Input 2.

Digital Inputs 3 through 7 are User defined.  
Digital Input 8 is reserved for Emergency Stop.  
Digital Input 9 is not available in this system.

When ordered, Temperature Probe leads are factory connected to J11 and J12. These are labeled 1 and 2.

NC = Normally Closed  
COM = Common  
NO = Normally Open

All relay contacts are shown with the relay deenergized.

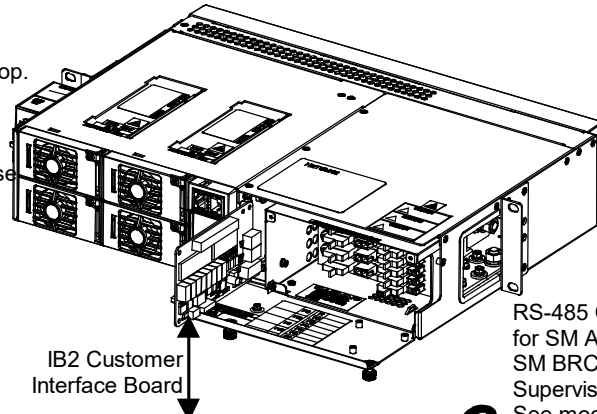

RS-485 Connection for SM AC, SM BAT, SM BRC, or SM IO Supervisory Modules. See module data sheets. (Functional with NCU only.)

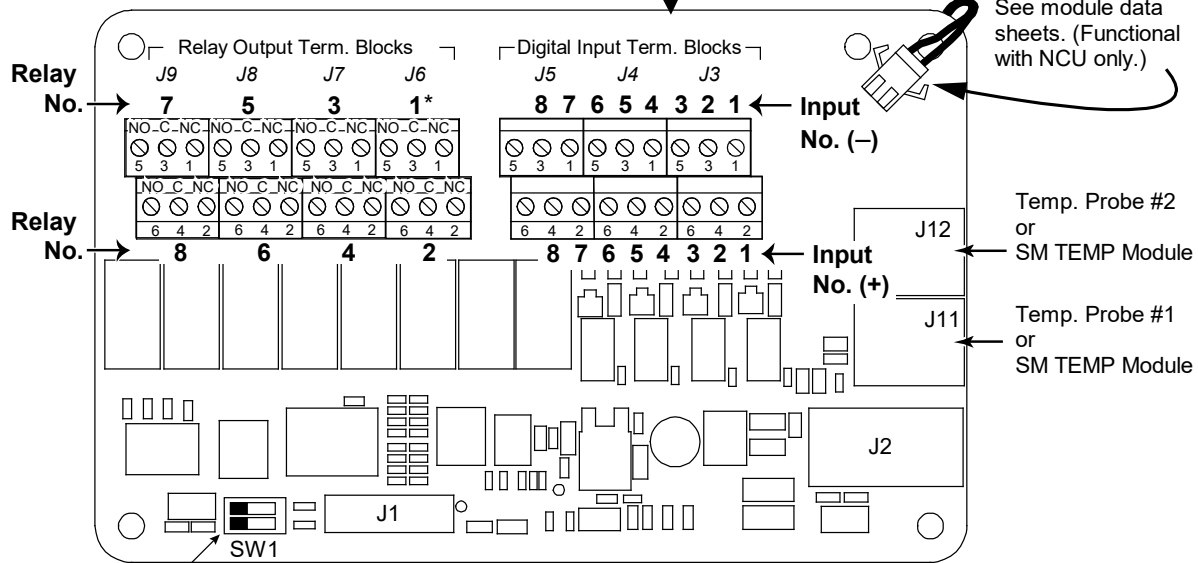

Switch sections must be set to this position to interface with SCU+/ACU+/NCU controller.

- ★ The relay assigned by the Controller to be the "Major Summary" (SCU+) or "Critical Summary" (ACU+ and NCU) alarm (relay 1 by default) will operate in the "Fail Safe Mode". "Fail Safe Mode" means Relay 1 is de-energized during an alarm condition, opening the contacts between the C and NO terminals, and closing the contacts between the C and NC terminals.

The remaining seven (7) alarm relays energize during an alarm condition, closing the contacts between the C and NO terminals, and opening the contacts between the C and NC terminals.

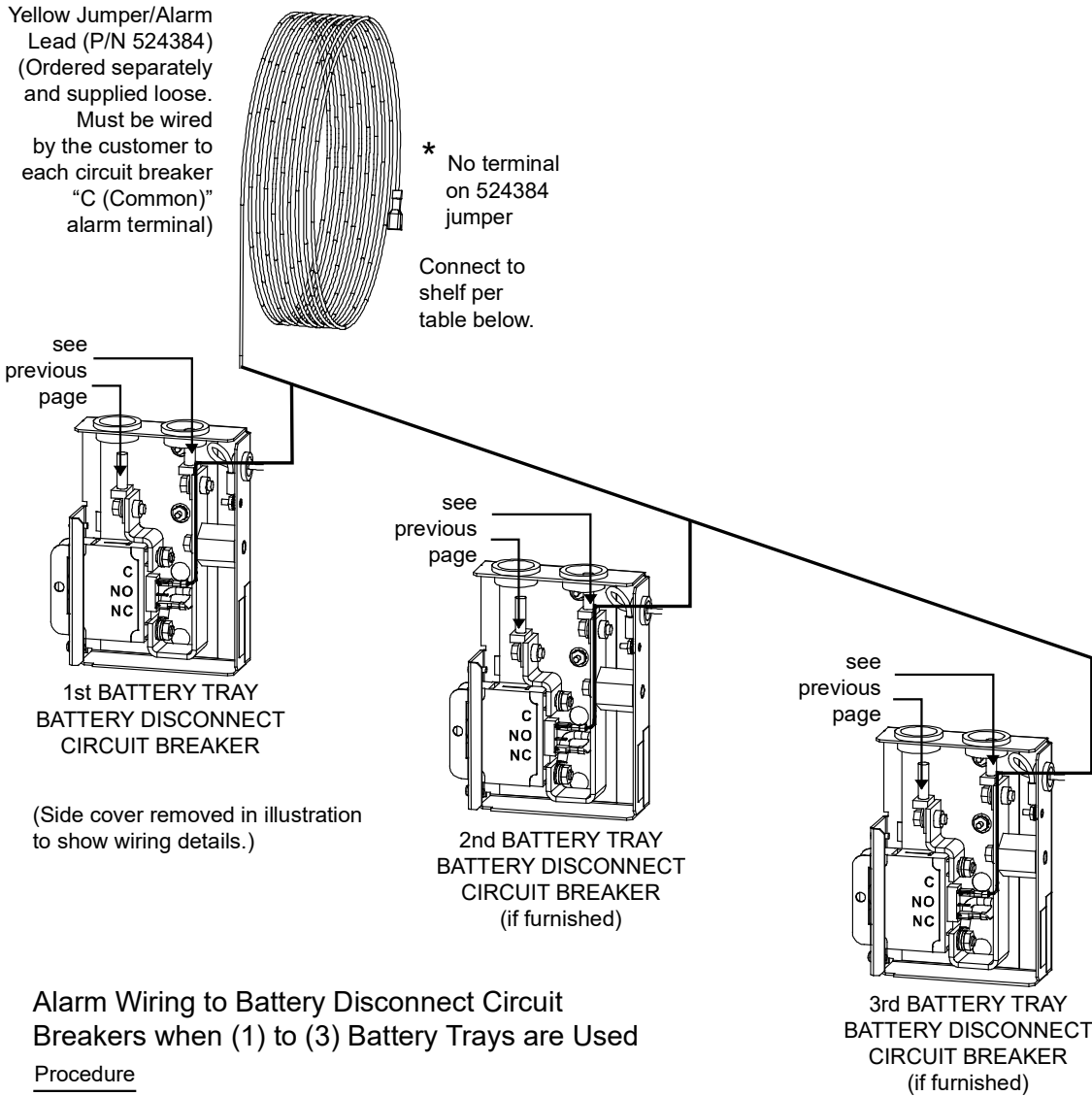

### Alarm Wiring to Battery Disconnect Circuit Breakers when (1) to (3) Battery Trays are Used

#### Procedure

1. Connect kit-supplied YELLOW jumper/alarm lead (P/N 524384) to circuit breaker "C (Common)" alarm terminals on ALL Battery Disconnect Circuit Breakers. Connect remaining per table below.
2. There is NO connection to the circuit breaker "NO (Normally Open)" alarm terminal.
3. On ALL Battery Disconnect circuit breakers, there should be a factory connected Jumper connected from the bottom terminal on the circuit breaker to the circuit breaker "NC (Normally Closed)" alarm terminal.

**External Battery Disconnect Circuit Breaker Alarm Input:**  
A battery disconnect circuit breaker alarm is activated when the circuit breaker is in the OFF position, and provides -48VDC to Digital Input # 2.

BREAKER ALARM CONNECTION		
Shelf List	Alarm Cable on shelf	CONNECT YELLOW WIRE TO:
1 or 2	545495 NO YES	Must order Cable 545495 R-BK Lead of 545495. Splice and heat shrink tubing included with 545495
5 or 6	541311 NO YES	Pin 3 of J3 on customer interface BD (negative side of Digital Input # 2) O-R Lead of 541311. Splice and heat shrink tubing included with 541311

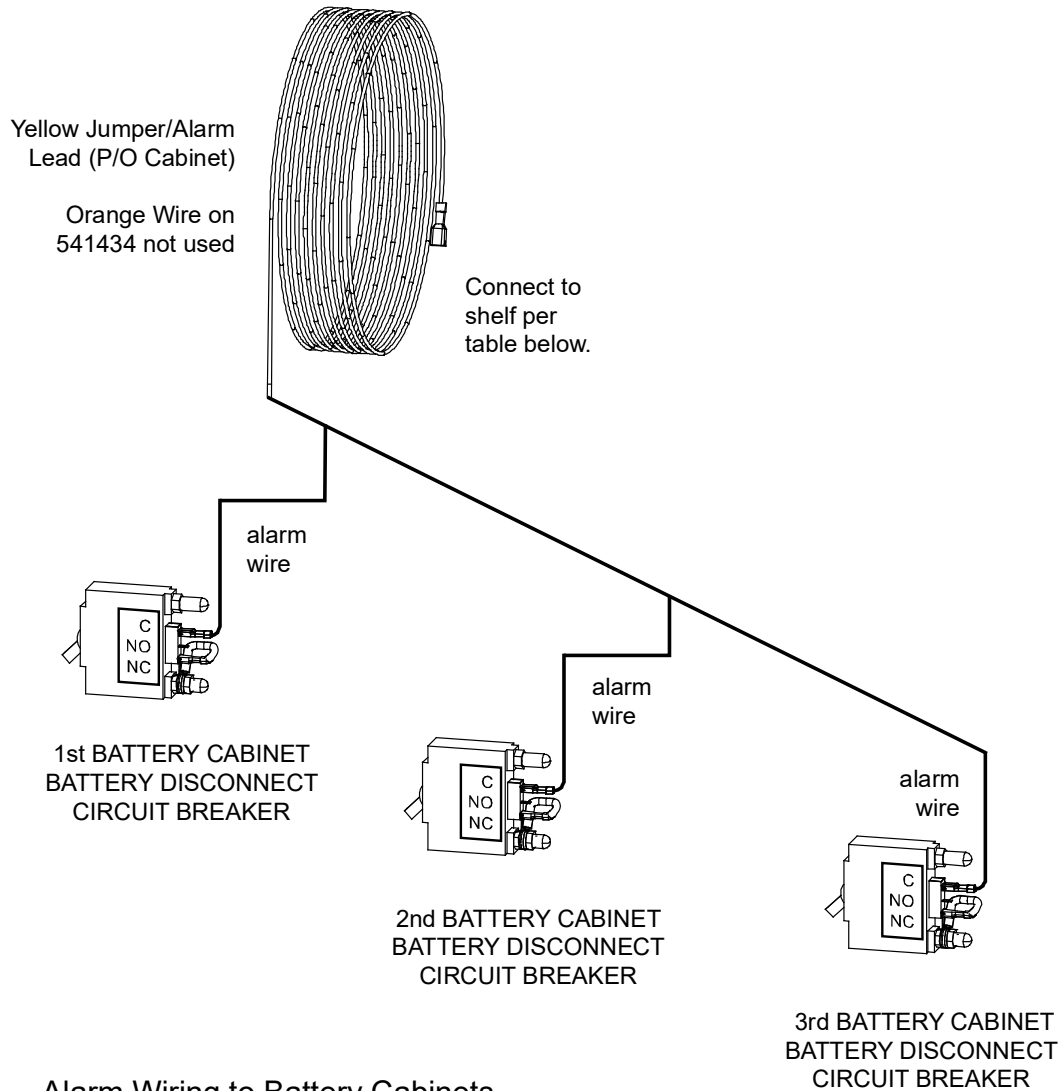

## Alarm Wiring to Battery Cabinets

### Procedure

1. Remove quick connect terminal from YELLOW battery cabinet alarm lead.
2. Wire per table below.

External Battery Disconnect Circuit Breaker Alarm Input:  
A battery disconnect circuit breaker alarm is activated when the circuit breaker is in the OFF position, and provides -48VDC to Digital Input # 2.

BREAKER ALARM CONNECTION		
Shelf List	Alarm Cable on shelf	CONNECT YELLOW WIRE TO:
1 or 2	545495 NO YES	Must order Cable 545495 R-BK Lead of 545495. Splice and heat shrink tubing included with 545495
5 or 6	541311 NO YES	Pin 3 of J3 on customer interface BD (negative side of Digital Input # 2) O-R Lead of 541311. Splice and heat shrink tubing included with 541311

**Load Distribution Wiring (GMT Fuses) (Lists BG and NG installed in a List 1 or 2, List 1 shown)**

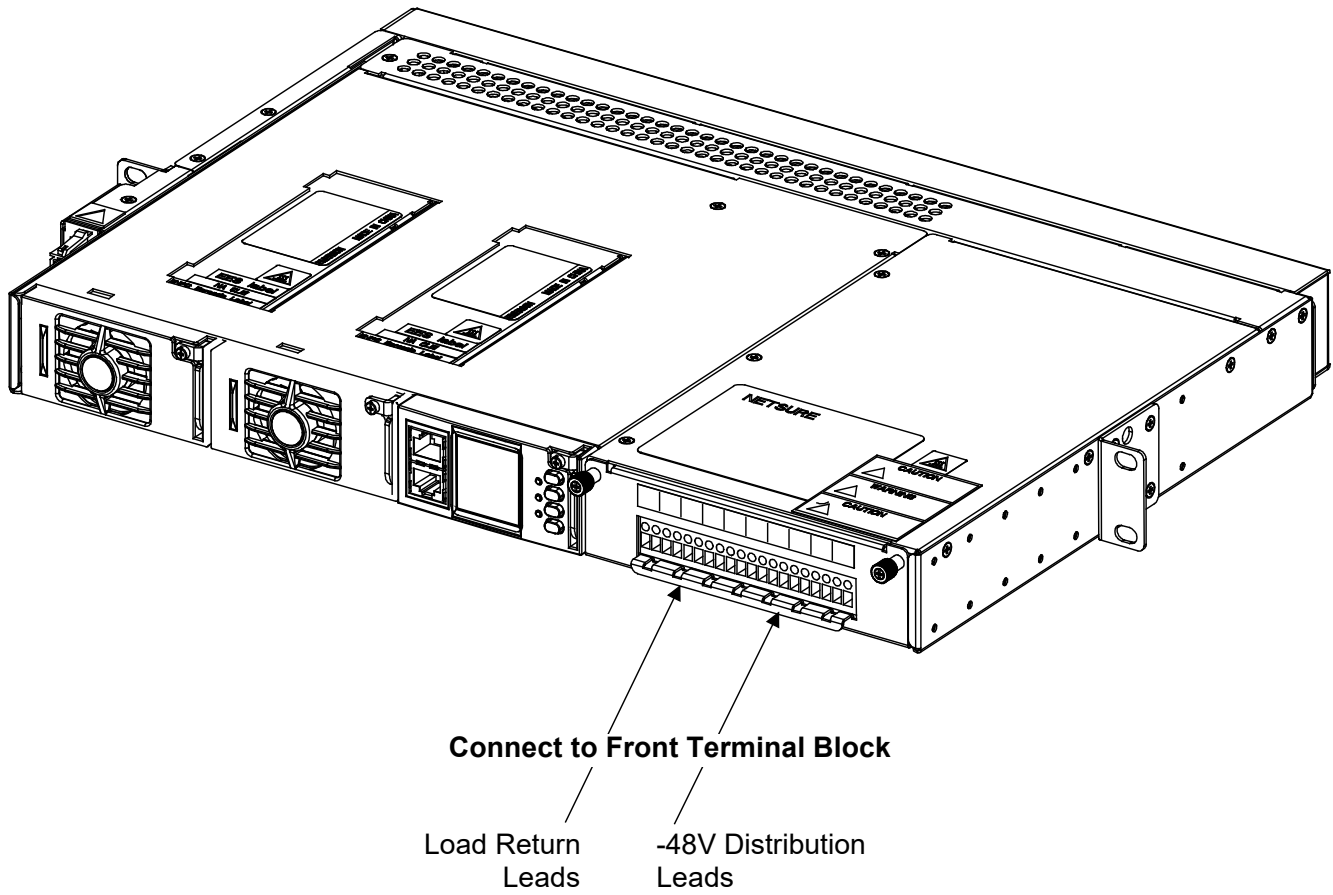

Fuse Position	Terminal	
	Load Return	Load (-48V)
1	1	2
2	3	4
3	5	6
4	7	8
5	9	10
6	11	12
7	13	14
8	15	16
9	17	18
10	19	20

**Load Distribution Wiring (GMT Fuses) (Lists BF and NF installed in a List 5 or 6, List 5 shown)**

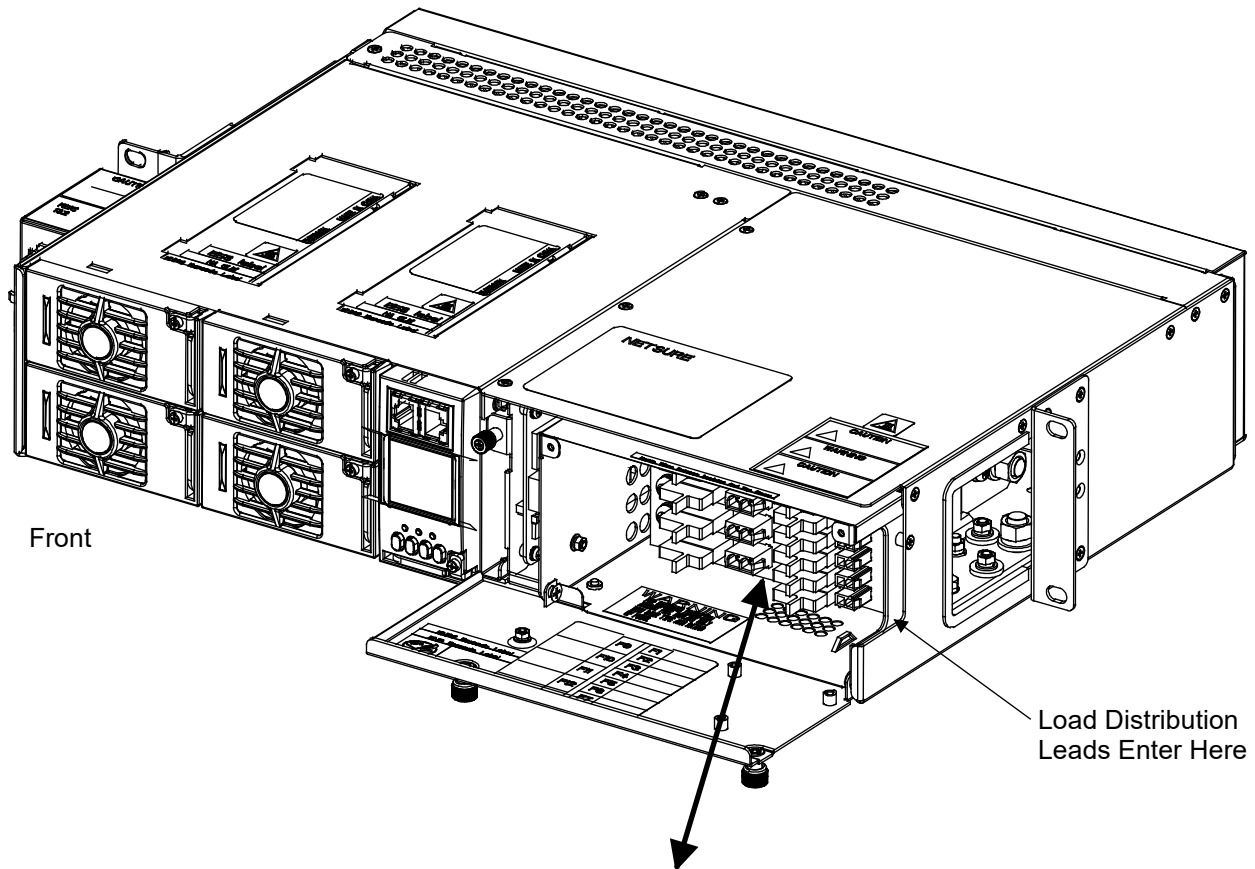

Front

Load Distribution Leads Enter Here

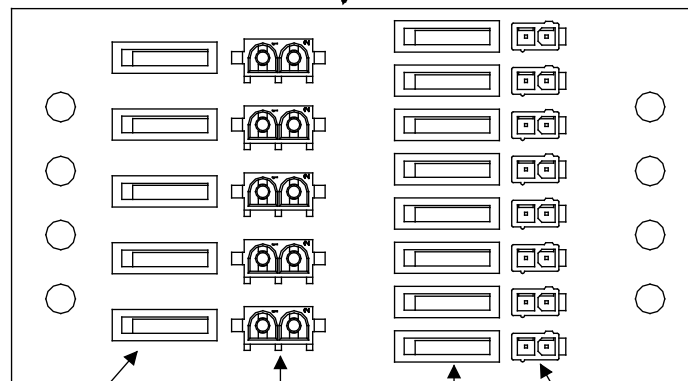

GMT Fuse Positions (Max. 15A)

GMT Fuse Load Distribution Leads Connect Here

GMT Fuse Positions (Max. 10A)

GMT Fuse Load Distribution Leads Connect Here

Mating Connectors and 12' Leads provided with List 62.

Mating Connectors and 12' Leads provided with List 61.

-48V on Left (Black Lead), Return on Right (White Lead)

-48V on Left (Black Lead), Return on Right (White Lead)



**Load Distribution Wiring (GMT Fuses) (Lists BC, NC, BA, and NA installed in a List 5 or 6, List 5 shown)**

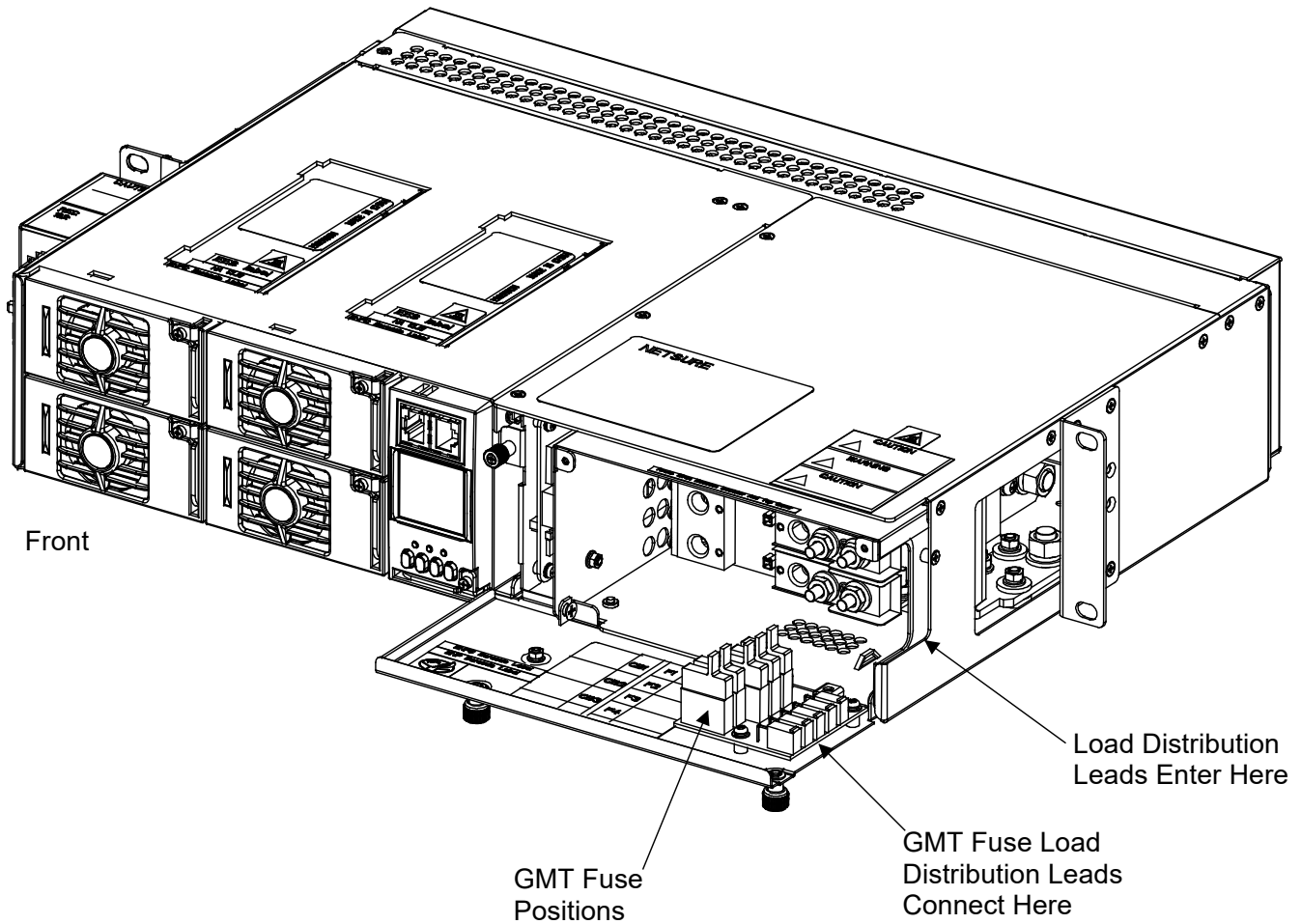

Mating Connectors and 12' Leads provided with List 60.

-48V on Left (Black Lead),  
Return on Right (White Lead);  
as viewed from side with door  
closed.

**Load Distribution Wiring (Optional Bullet Nose 6-Position GMT Fuse Module)**

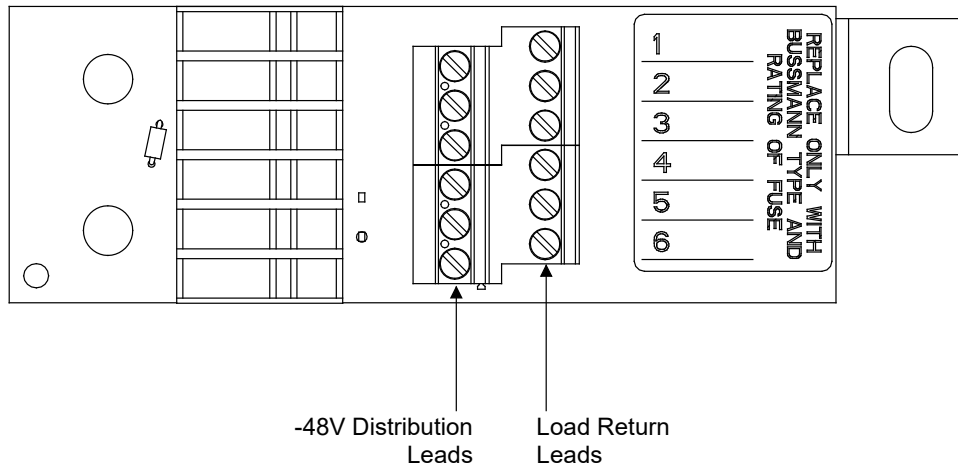

**Load Distribution Wiring (Circuit Breakers) and CO Ground Wiring (Lists BC, and NC installed in a List 5 or 6, List 5 shown)**

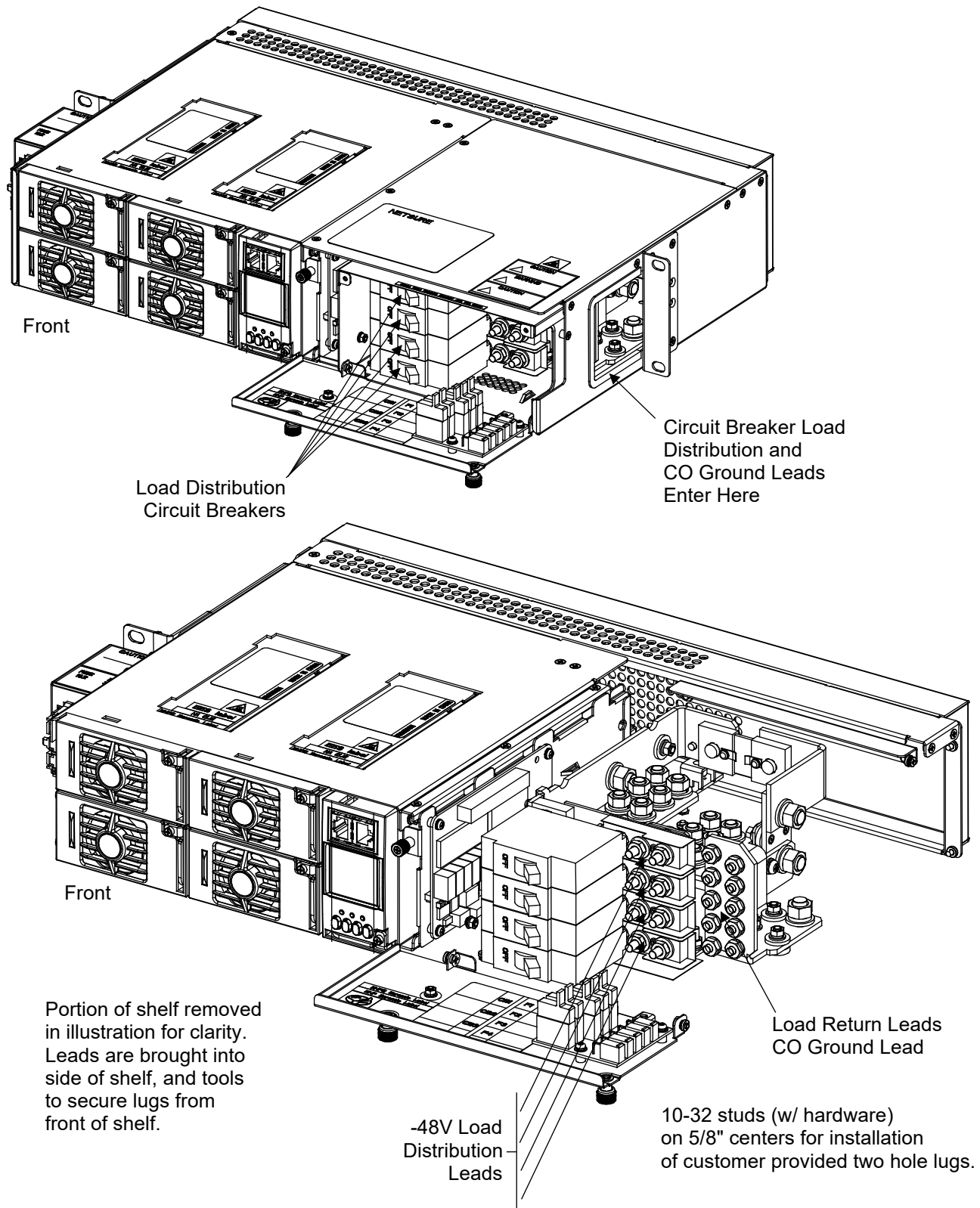

**Load Distribution Wiring (Circuit Breakers), Input Battery Wiring (Circuit Breakers),  
and CO Ground Wiring (Lists BA and NA installed in a List 5 or 6, List 5 shown)**

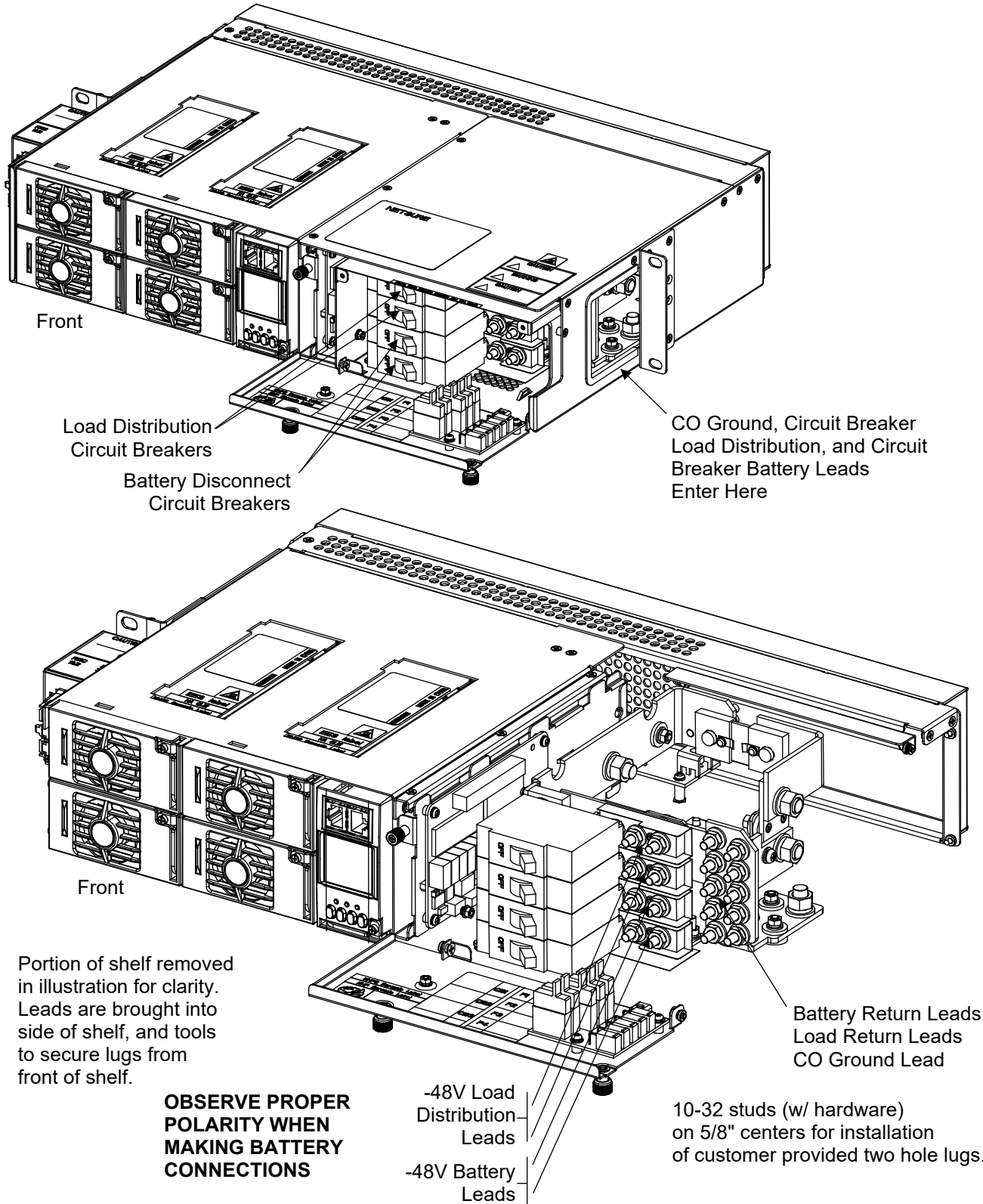

**Load Distribution Wiring (GMT Fuses) (List KG)**

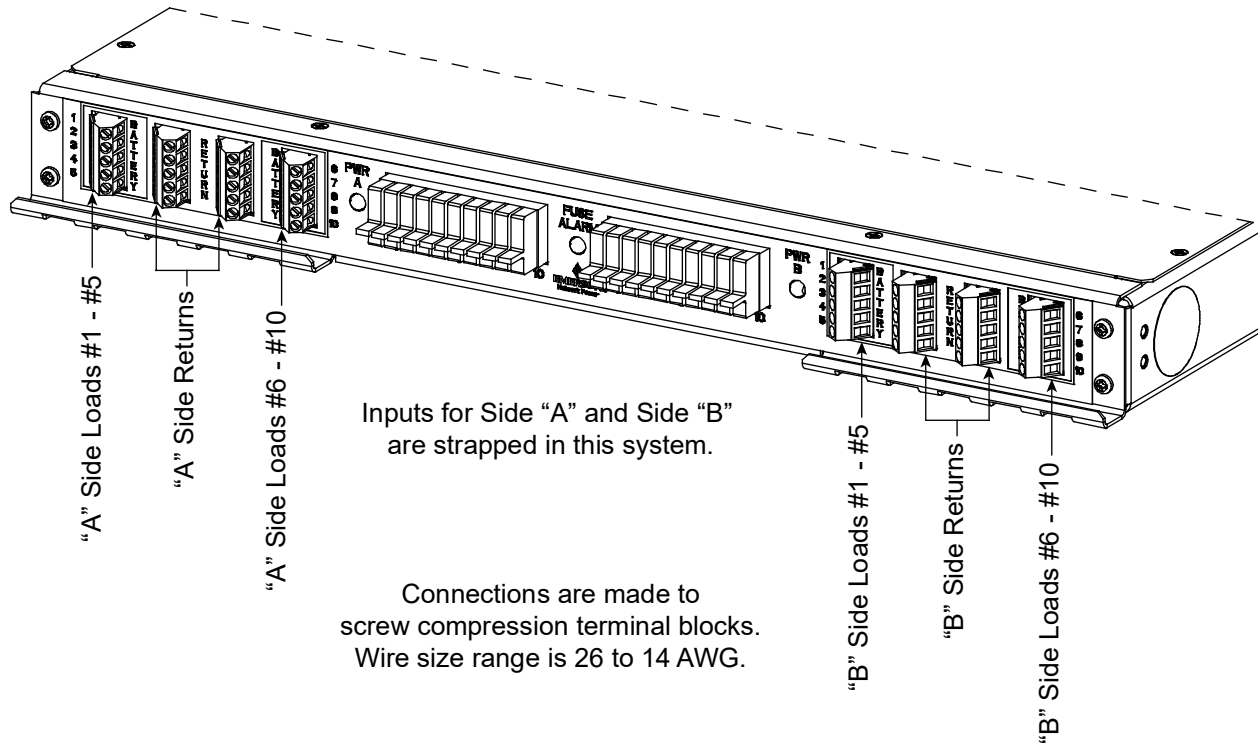

**Input Battery Wiring (Lists BG and NG installed in a List 1 or 2, List 1 shown)**

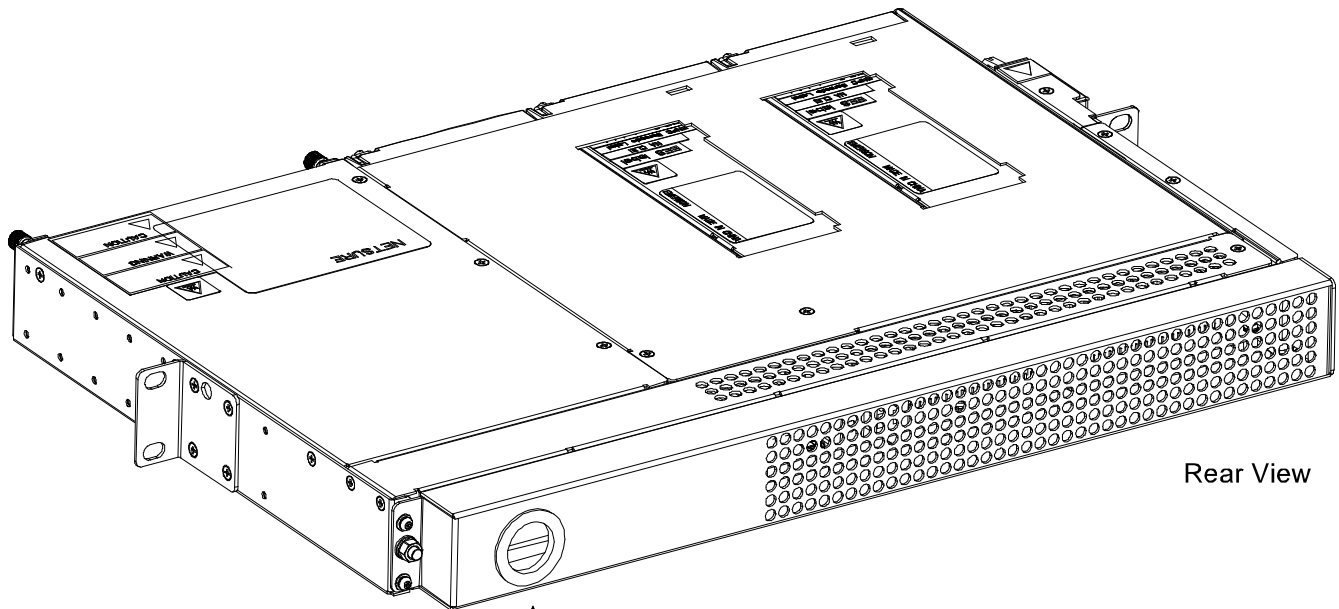

Rear View

Connect battery leads to factory installed leads exiting the shelf here. These leads are factory terminated in an Anderson connector. A mating half to this connector is provided for connection to customer battery leads. External battery cables are also available to connect 1 (List 71 and 73) or 2 (List 72) strings of batteries to the system.

OBSERVE PROPER POLARITY.  
LEADS AND CONNECTORS ARE  
MARKED WITH A PLUS AND MINUS  
SYMBOL OR TEXT.

Minus (-48V Battery)  
Plus (Battery Return)

**Input Battery Wiring (Lists BF, NF, BC, and NC installed in a List 1 or 5, List 5 shown)  
and CO Ground Wiring (Lists BF and NF installed in a List 1 or 5, List 5 shown)**

List NF Distribution Unit shown. List BF, BC, and NC similar.

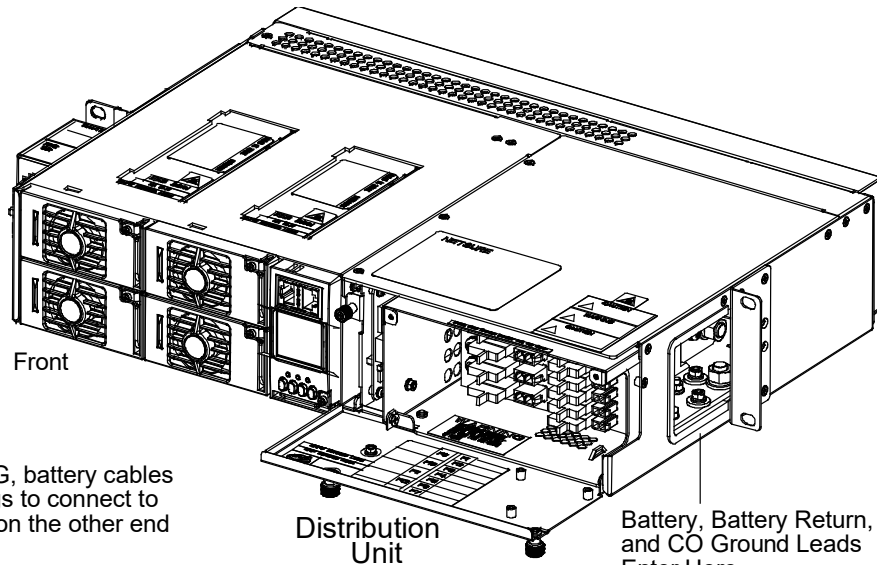

List 65 provides 3' long, 2 AWG, battery cables terminated on one end with lugs to connect to the input battery landings and on the other end with an Anderson connector.

List 66 provides 12' long, 2 AWG, battery cables terminated on one end in an Anderson connector and left unterminated at the remaining end for connection of battery lugs.

Battery: 1/4-20 studs (w/hardware) on 5/8" centers for installation of customer provided two hole lugs.

CO Ground: 10-32 studs (w/hardware) on 5/8" centers for installation of customer provided two hole lugs.

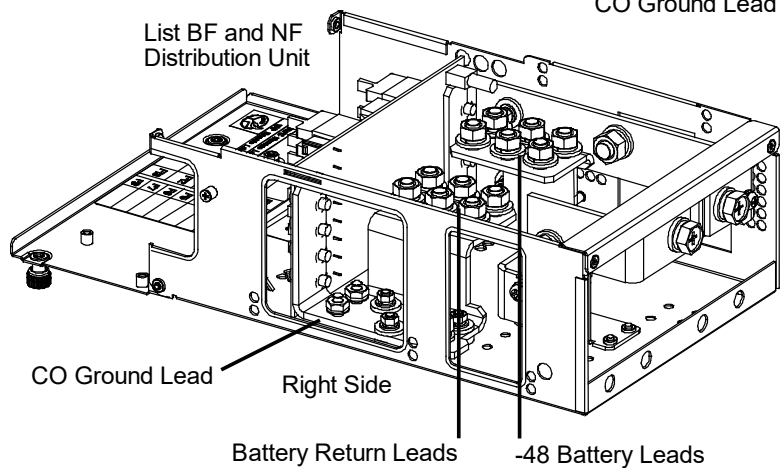
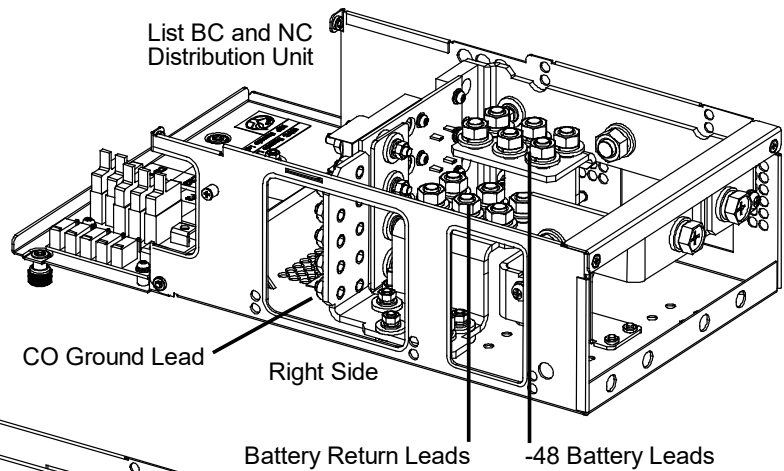

**OBSERVE PROPER POLARITY WHEN MAKING BATTERY CONNECTIONS**

## SPECIFICATIONS

### 1. SYSTEM

#### 1.1 Environmental Ratings

##### 1.1.1 Operating Ambient Temperature Range (Specification Compliant):

(A) -40°C (-40°F) to +65°C (+149°F) with derating output.

(B) -40°C (-40°F) to +40°C (+104°F) with full power performance.

##### 1.1.2 Storage Ambient Temperature Range: -40°C (-40°F) to +75°C (+167°F).

##### 1.1.3 Humidity: This Power System is capable of operating in an ambient relative humidity range of 0% to 90%, non-condensing.

##### 1.1.4 Altitude: 2000 m (6560 ft) at full power (power limited for heights above 2000 m).

##### 1.1.5 Mounting: This product is intended only for installation in a Restricted Access Location on or above a non-combustible surface.

This product must be located in a Controlled Environment with access to Craftspersons only.

This product is intended for installation in Network Telecommunication Facilities (CO, vault, hut, or other environmentally controlled electronic equipment enclosure).

This product is intended to be connected to the common bonding network in a Network Telecommunication Facility (CO, vault, hut, or other environmentally controlled electronic equipment enclosure).

Typical industry standards recommend minimum aisle space clearance of 2'6" for the front of the relay rack and 2' for the rear of the relay rack.

Separate shelves are available for mounting in either a 19" or 23" wide relay rack (1" or 1-3/4" multiple drillings for the 2U shelf and 1-3/4" multiple drillings for the 1U shelf).

Mounting angles are positioned for a 5-inch front projection mounting only.

Flush mounting is done using optional kits.

##### 1.1.6 Ventilation Requirements: Rectifier and mounting shelf ventilating openings must not be blocked and temperature of air entering rectifiers must not exceed rated Operating Ambient Temperature Range stated above.

#### 1.2 Compliance Information

##### 1.2.1 Surge Protection: See UM1R481000.

**Note:** *This level of protection is a widely used standard for telecommunications power equipment. As with all such equipment, it is the end user's responsibility to provide an adequately sized Surge Suppression Device at the commercial power service entrance of the building that reduces all incoming surges to levels below the classes/categories stated for the equipment.*

##### 1.2.2 Safety Compliance:

(A) This unit meets the requirements of UL 60950, Standard for Information Technology Equipment, and is UL Recognized as a power supply for use in Telephone, Electronic Data Processing, or Information Processing Equipment.

(B) This unit meets the requirements of CAN/CSA 22.2, No. 60950-00 and is tested and Certified by UL ("c UR") as a Component Type Power Supply.



1.2.3 EMC and Safety: Complies with the Low-Voltage Directive, 73/23/EEC. Complies with Emissions and Immunity requirements as specified in GR-1089-Core Issue 4.

<b>EMC</b>		
<b>Emissions</b>		<b>Test Level</b>
EN 55022: 1998 CFR 47 – Part 15 GR-1089 Issue 4	Conducted	Class B
	Radiated	Class B
<b>Immunity</b>		
GR-1089 Issue 4	EN 61000-4-2 Electrostatic Discharge	8kV / 15kV
	EN 61000-4-4 Electric Fast Transients	0.25kV / 0.5kV
	Radiated Immunity	8.5V/m
	Conducted Immunity	89dBuA
	Surge IEEE C62.41	2kV / 6kV
<b>SAFETY</b>		
EN 60950-1: 2001	Safety of Information Technology Equipment, including Electrical Business Equipment	

1.2.4 NEBS Compliance: Compliance verified by a Nationally Recognized Testing Laboratory (NRTL) per GR-1089-CORE and GR-63-CORE. Contact Vertiv for NEBS compliance reports.

For Vertiv™ NetSure™ 211NGFB to remain compliant during a fan failure condition, the backup battery connection must be utilized to provide sufficient power to the loads for up to eight (8) hours when the system is operated at greater than 50% output power. If no backup battery connection is used, the system must operate with a redundant module installed.

### 1.3 Standard Features

1.3.1 AC Input Connections: AC input cable assemblies and line cords are available.

- (A) List 1 and 2: Mounted to the side of the shelf is an AC input housing with one (1) plug-in connector for one (1) AC input feed.
- (B) List 5 and 6: Mounted to the side of the shelf is an AC input housing with two (2) plug-in connectors for two (2) AC input feeds.

1.3.2 Battery Connections: Battery cables are available.

- (A) List 1 and 2: Battery leads are connected to an Anderson connector exiting the rear of the unit.
- (B) Lists 5 and 6: Battery and battery return leads terminated in two-hole lugs are connected to threaded studs located inside the Distribution Unit. Battery leads are brought into the right side (as viewed from the front) of the shelf.

1.3.3 Load Connections:

- (A) List 1 and 2: Load and load return leads are connected to a screw-type terminal block located on the front of the shelf.
- (B) Lists 5 and 6: Load distribution (circuit breakers, if furnished) and load return leads terminated in two-hole lugs are connected to threaded studs located inside the Distribution Unit. Load leads are brought into the right side (as viewed from the front) of the shelf and are accessible from the front of the shelf.  
Load distribution (GMT fuses) and load return leads are connected to receptacles located inside the Distribution Unit. Load leads are brought into the right side (as viewed from the front) of the shelf and are accessible from the front of the shelf.

1.3.4 Alarm and Monitoring Connections: Customer wiring cables are available.

- (A) List 1 and 2: Relay output and digital input leads are connected to screw-type terminal blocks located on the SCU+ or NCU located inside the shelf. These leads enter the rear of the shelf.
- (B) Lists 5 and 6: Relay output and digital input leads are connected to screw-type terminal blocks located on the Customer Interface Board located inside the shelf. These leads enter the right side (as viewed from the front) of the shelf and are accessible from the front of the shelf.

1.3.5 Dimensions and Weights: Refer to the PHYSICAL SIZE INFORMATION section of this document.

2. RECTIFIER

Refer to the Rectifier Instructions (UM1R481000).

3. CONTROLLER

Refer to the Controller Instructions (UM1M830BNA).

For controller factory settings, refer to the Controller Configuration Drawing (C-drawing).

**MECHANICAL SPECIFICATIONS**

**Overall Dimensions – List 1**

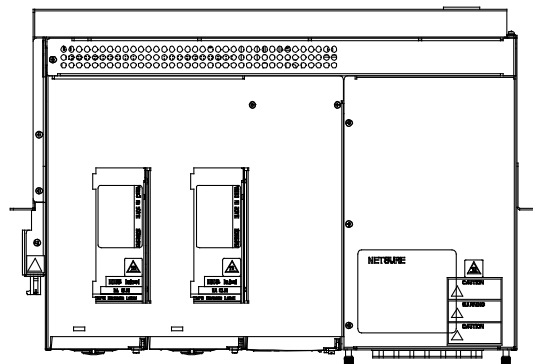

Top View

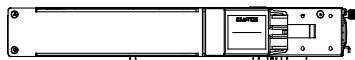

Left Side View

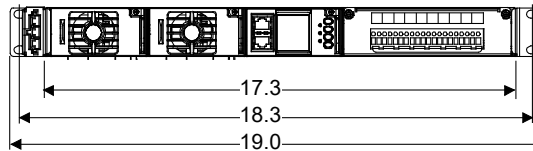

Front View

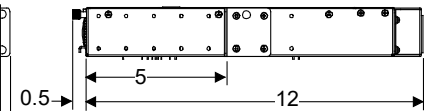

Right Side View

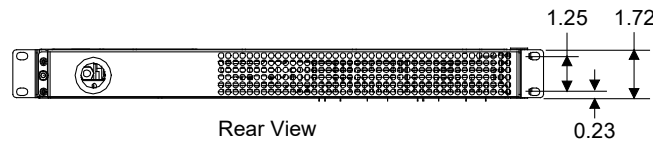

Rear View

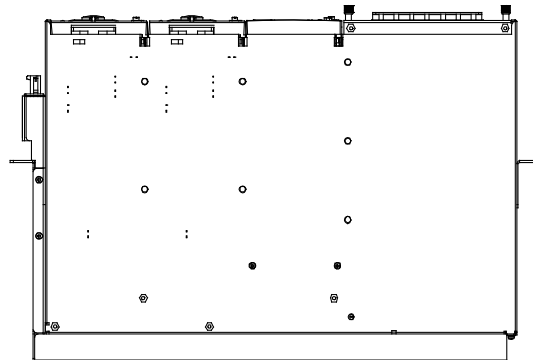

Bottom View

Notes:

1. All dimensions are in inches, unless otherwise specified.
2. Weight in LBS.  
Net: 16  
Shipping:
3. Finish: Front Panels are Gray  
Shelf is Galvaneal.

**Additional Dimensions – List 1 with Wall Mounting Kit (P/N 541285)**

**Horizontal Wall Mounting**

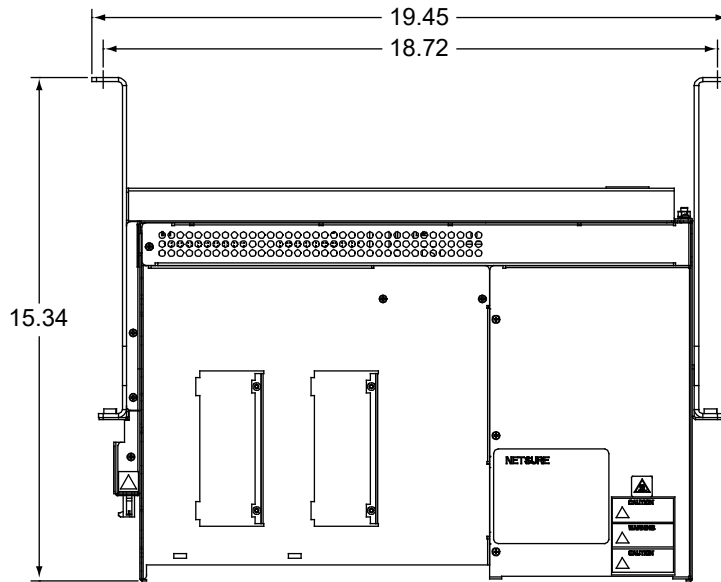

Top View

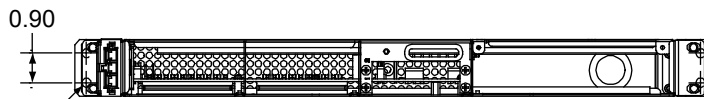

Rear View

0.277 Dia. Clearance  
Hole in Bracket  
for Wall Fastener  
(2 per bracket)

Note: All dimensions are in inches.

**Vertical Wall Mounting**

0.277 Dia. Clearance  
Hole in Bracket  
for Wall Fastener  
(2 per bracket)

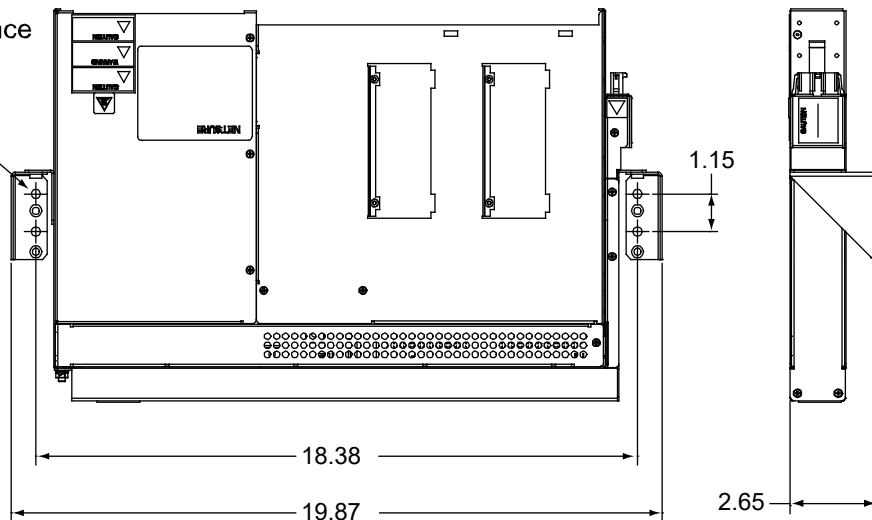

Top View

Right Side  
View

**Additional Dimensions – List 1 with Optional 19” Rear Cover Kit, P/N 555260**

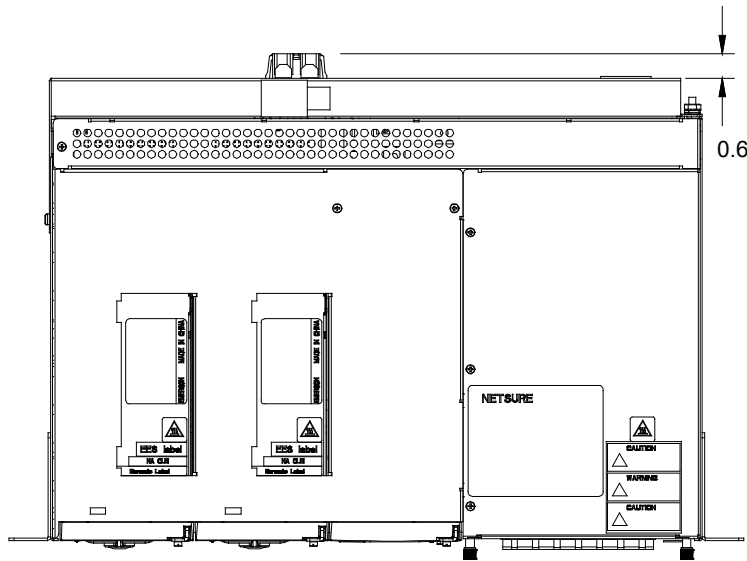

Top View

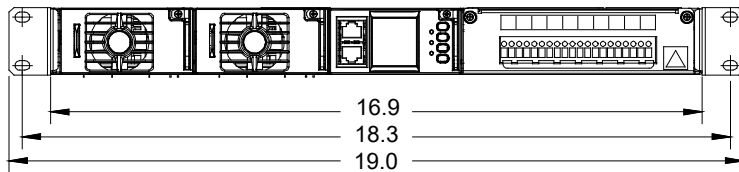

Front View

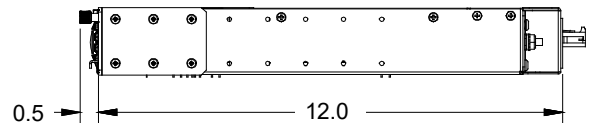

Right Side View

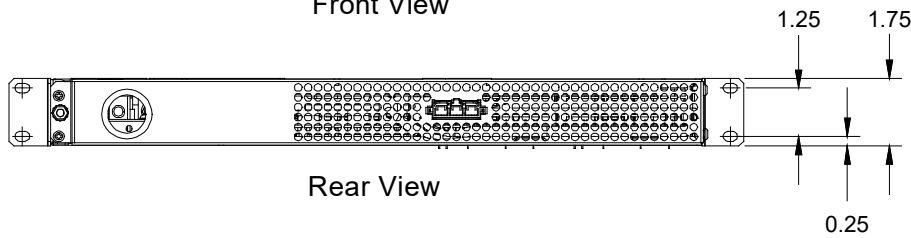

Rear View

**Overall Dimensions – List 2**

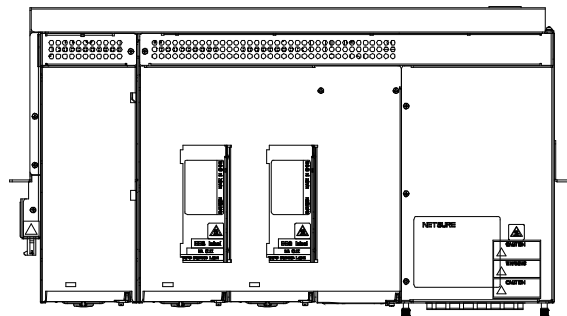

Top View



Left Side View

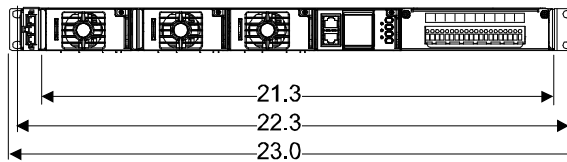

Front View

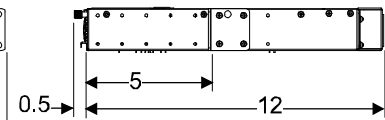

Right Side View

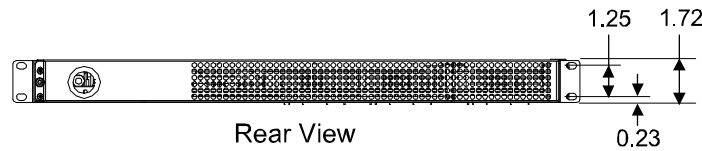

Rear View

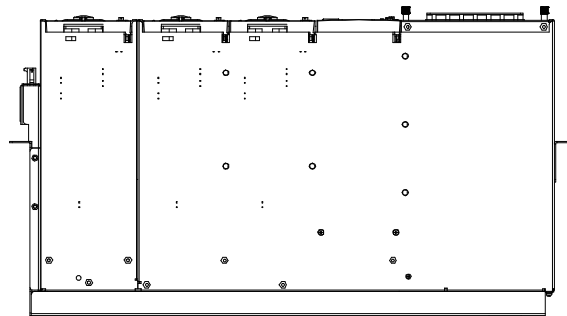

Bottom View

Notes:

1. All dimensions are in inches, unless otherwise specified.
2. Weight in LBS.  
Net: 20.5  
Shipping:
3. Finish Front Panels are Gray  
Shelf is Galvaneal.

**Additional Dimensions – List 2 with Wall Mounting Kit (P/N 541285)**

**Horizontal Wall Mounting**

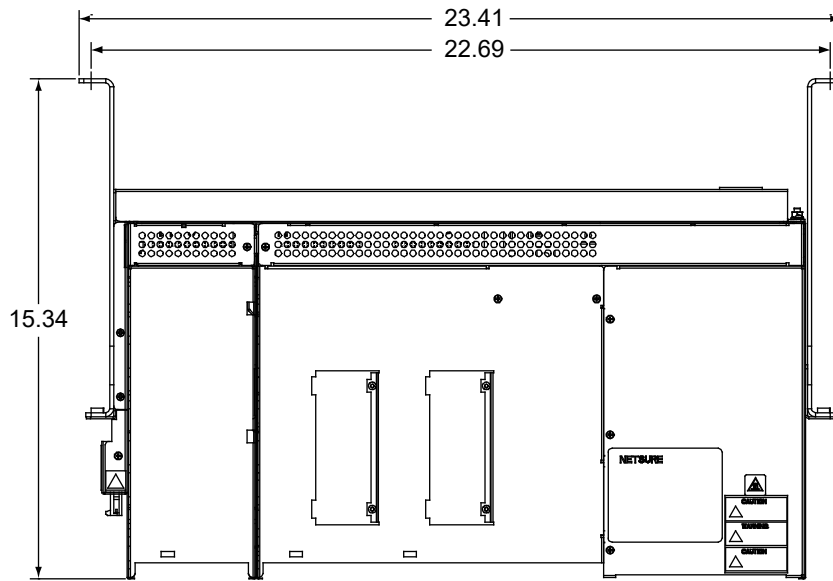

Top View

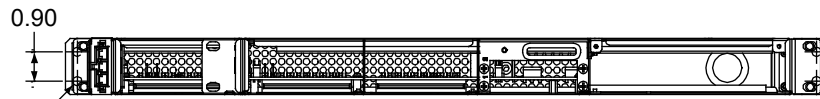

Rear View

0.277 Dia. Clearance  
Hole in Bracket  
for Wall Fastener  
(2 per bracket)

Note: All dimensions are in inches.

**Vertical Wall Mounting**

0.277 Dia. Clearance  
Hole in Bracket  
for Wall Fastener  
(2 per bracket)

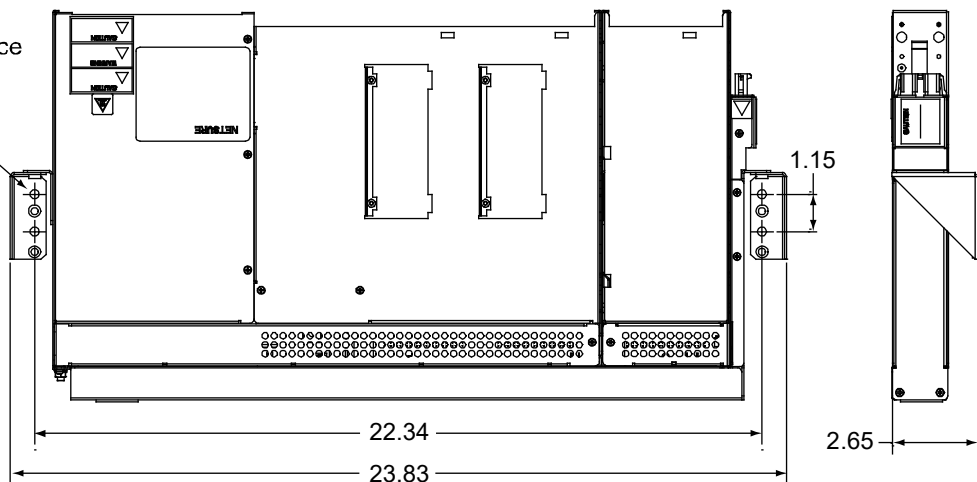

Top View

Right Side  
View

**Overall Dimensions – List 5**

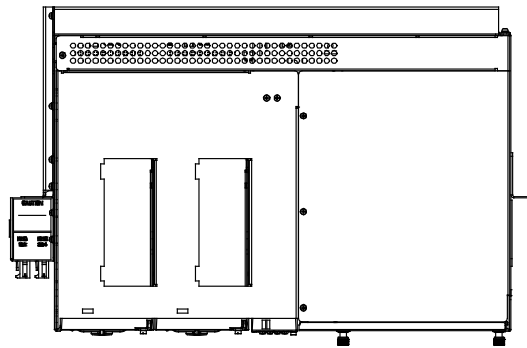

Top View

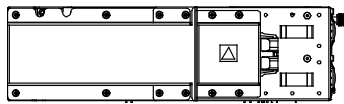

Left Side View

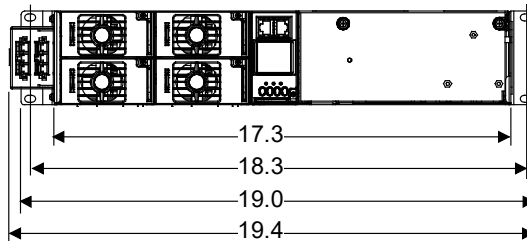

Front View

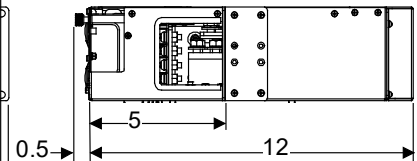

Right Side View

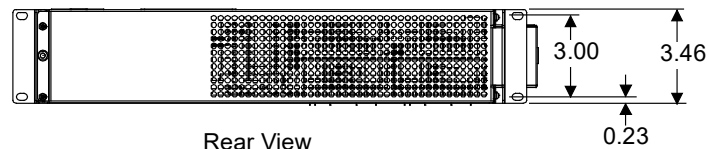

Rear View

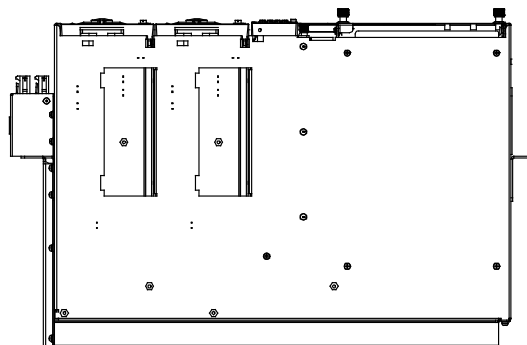

Bottom View

Notes:

1. All dimensions are in inches, unless otherwise specified.
2. Weight in LBS.  
Net: 30  
Shipping:
3. Finish: Front Panels are Gray  
Shelf is Galvaneal.



**Overall Dimensions – List 6**

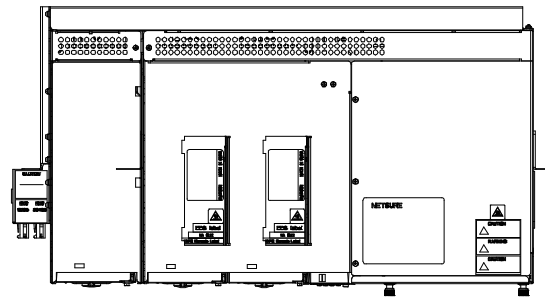

Top View

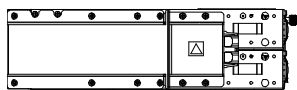

Left Side View

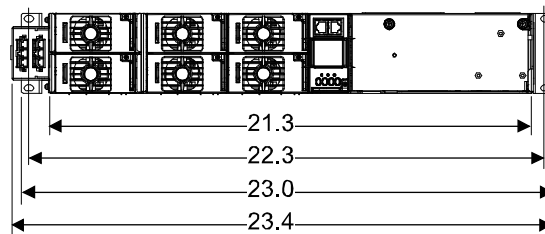

Front View

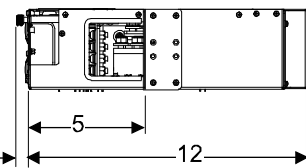

Right Side View

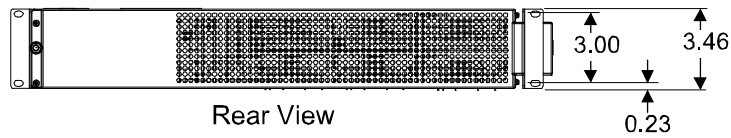

Rear View

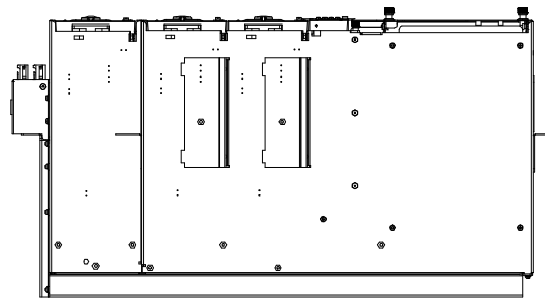

Bottom View

Notes:

1. All dimensions are in inches, unless otherwise specified.
2. Weight in LBS.  
Net: 39  
Shipping:
3. Finish: Front Panels are Gray  
Shelf is Galvaneal.

**Additional Dimensions – Lists 1, 2, 5 and 6 with Wall Mounting Kit (P/N 553203)**

**Lists 1 and 2**

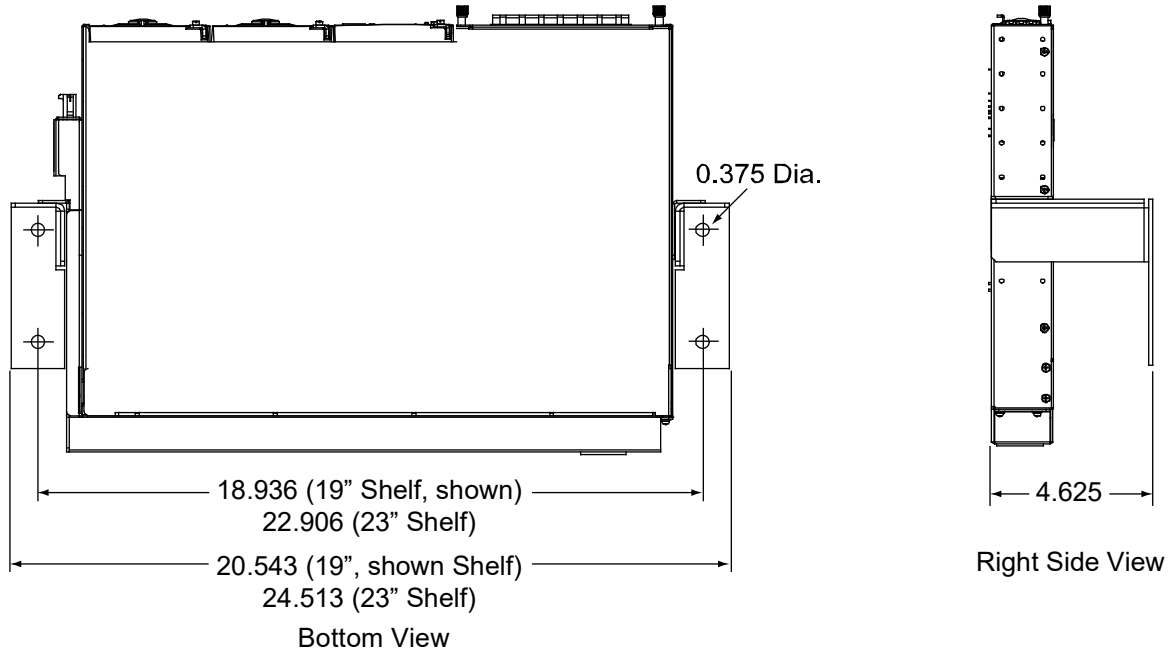

Note: All dimensions are in inches.

**Lists 5 and 6**

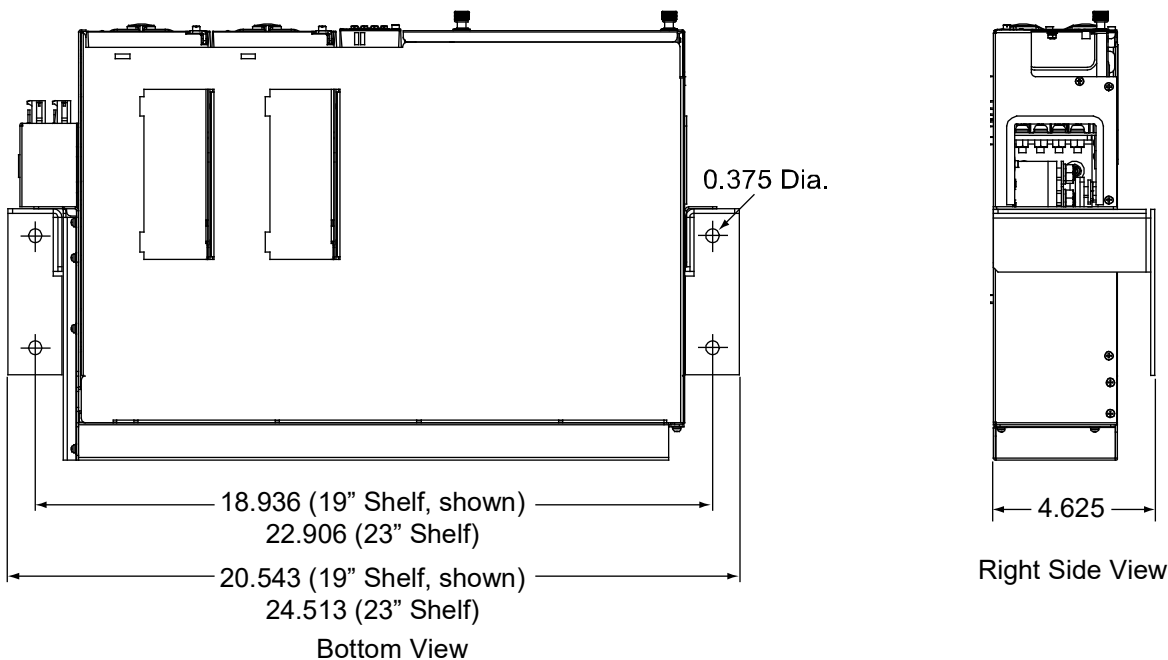

**Overall Dimensions – List KG**

Notes:

1. Dimensions in inches unless otherwise specified.
2. Finish: Gray
3. Weight:  
Net:  
Shipping:

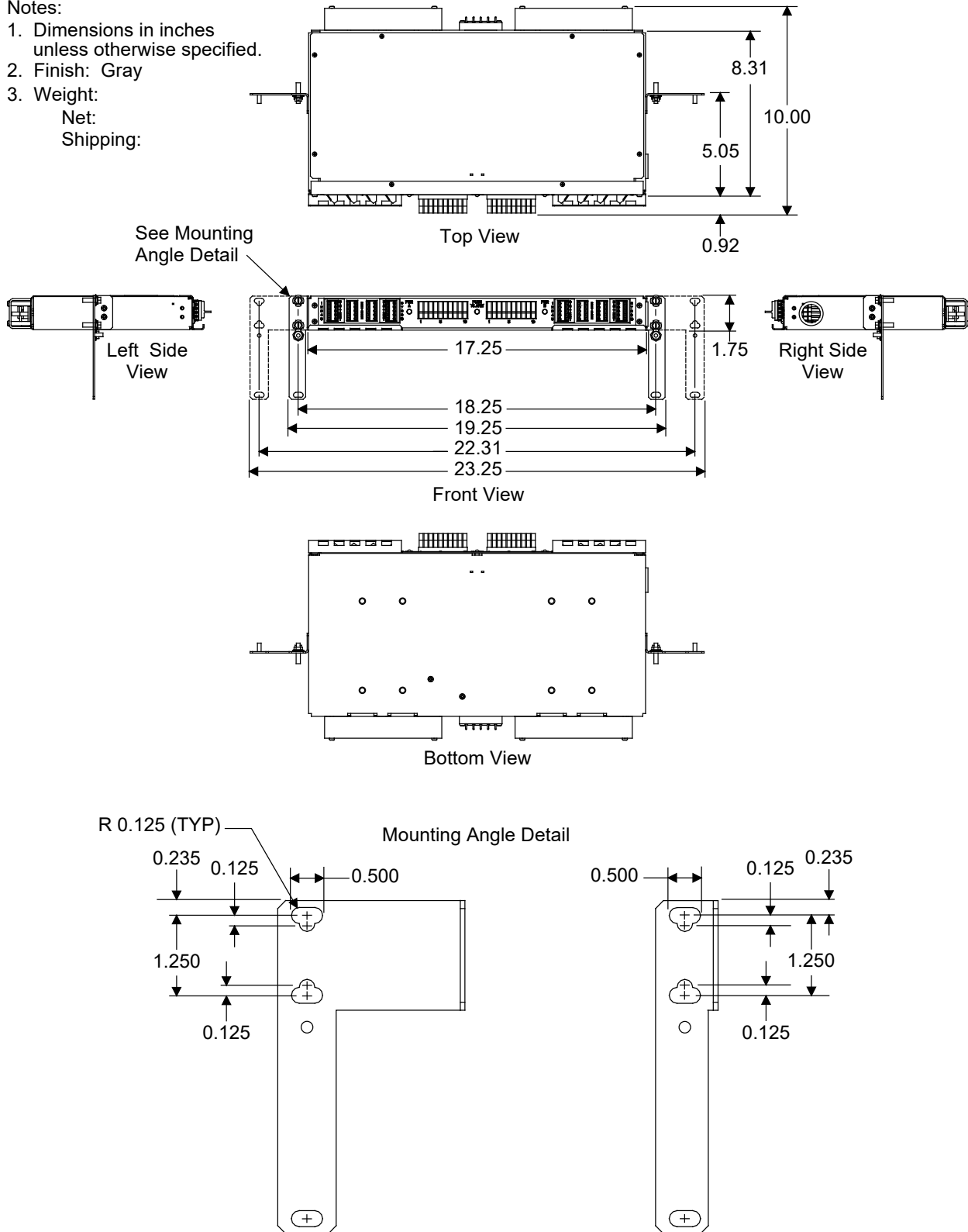

### Overall Dimensions – 19” Battery Tray

Optional Battery Disconnect Circuit Breakers  
(Shown on Right Side, Available on Either Side)

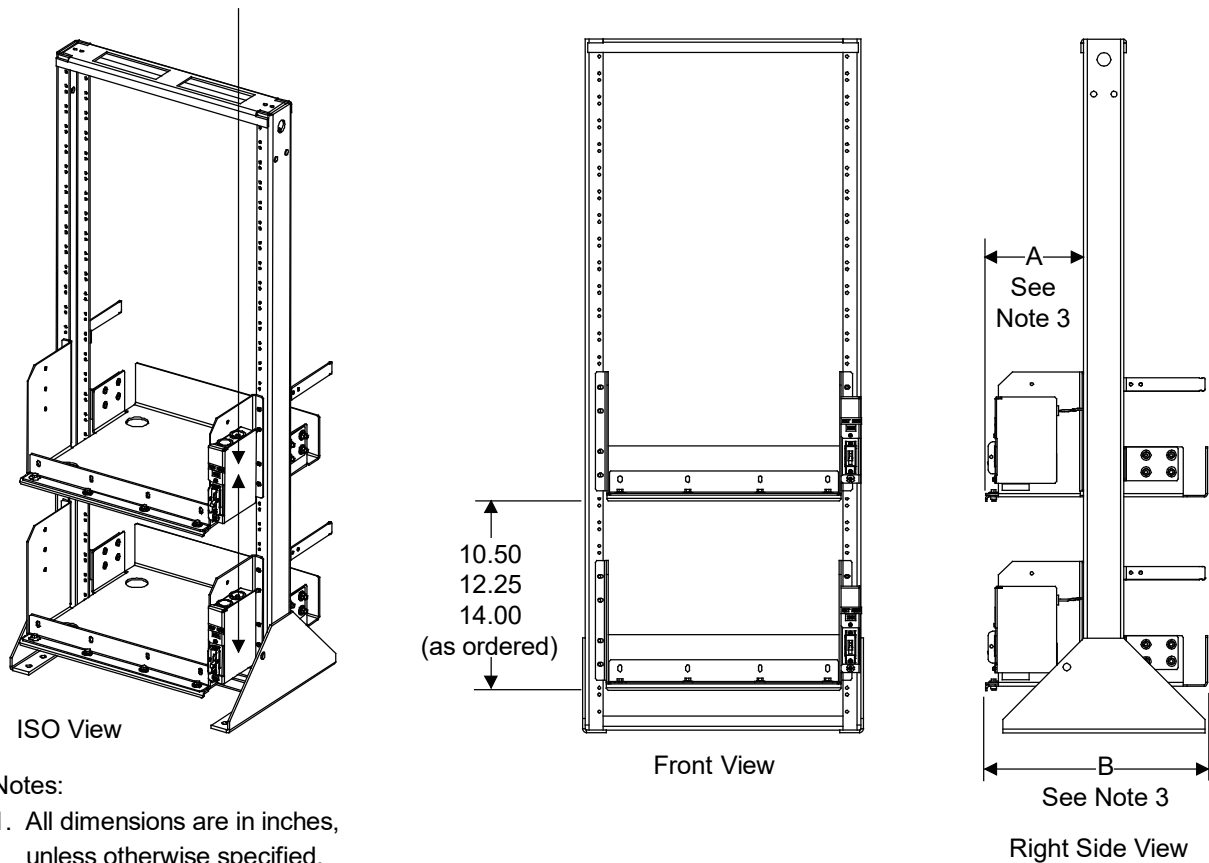

**Notes:**

1. All dimensions are in inches, unless otherwise specified.
2. P/N 558047 tray shown.  
P/Ns 541034, 540841 and 548213 similar.

3.

Tray P/Ns	Dimension A	Dimension B
558047	7.78	17.60
541034	7.03	20.95
540841	6.90	12.50
548213	7.28	22.35

4. Weight in LBS.  
(per tray, less batteries).

Tray P/Ns	With Circuit Breaker Option	Without Circuit Breaker Option
558047	25.0 lbs	23.0 lbs
541034	25.3 lbs	23.3 lbs
540841	18.5 lbs	16.5 lbs
548213	26.0 lbs	24.0 lbs

5. Finish: Gray
6. Maximum trays available per rack is three (3).

### Overall Dimensions – 23” Battery Tray

Optional Battery Disconnect Circuit Breakers  
(Shown on Right Side, Available on Either Side)

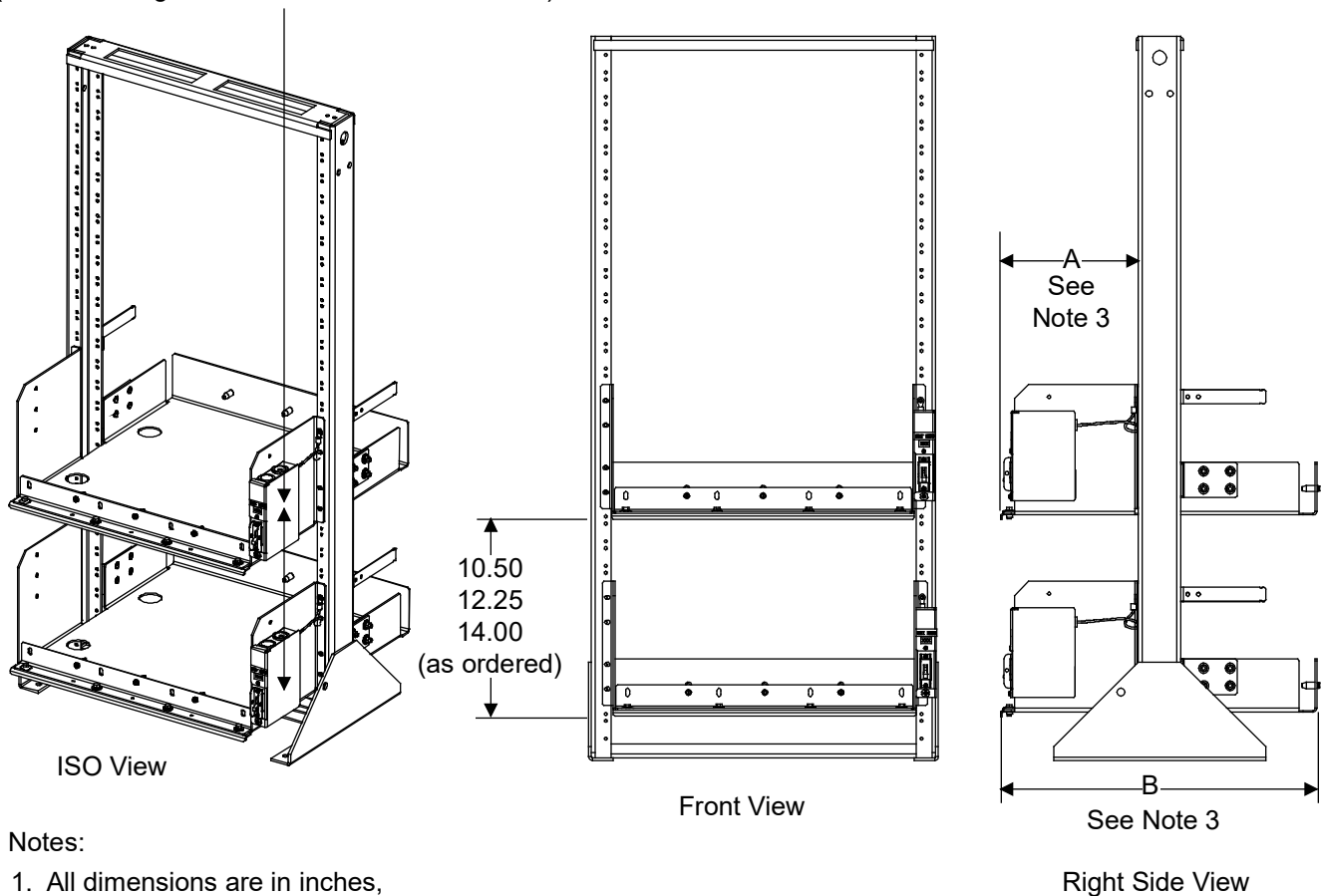

**Notes:**

1. All dimensions are in inches, unless otherwise specified.
2. P/N 528496 tray shown. P/N 540842 and 557573 similar.
- 3.

Tray P/N	Dimension A	Dimension B
528496	9.781	22.44
540842	6.90	12.50
557573	10.48	23.14

4. Weight in LBS. (per tray, less batteries).

Part No.	With Circuit Breaker Option	Without Circuit Breaker Option
528496	33 lbs	29 lbs
540842	20 lbs	18 lbs
557573	25 lbs	23 lbs

5. Finish: Gray
6. Maximum trays available per rack is three (3).

## BATTERY MANUFACTURER INFORMATION

Some equipment described in this System Application Guide is designed to accommodate batteries from various manufacturers. The following are referenced in this document.

**C&D:** C&D Technologies, Inc., Powercom Div., 1400 Union Meeting Road, Blue Bell, PA 19422-0858

**Deka:** East Penn Mfg. Co., Inc., Lyon Station, PA 19536-0147

**Douglas:** Douglas Battery Mfg. Co., 500 Battery Dr., Winston-Salem, NC 27117-2159

**Northstar:** NorthStar Battery Co. LLC, 4000 Continental Way, Springfield, MO 65803

**PowerSafe EnerSys™:** EnerSys Inc., Reading, PA, 196212-4145

## RELATED DOCUMENTATION

<b>Installation Instructions:</b>	Section 6031
<b>User Instructions:</b>	Section 6032
<b>Battery Cabinet Spec. No. 541434 Installation and User Instructions:</b>	Section 6023
<b>Battery Cabinet Spec. No. 545534 Installation and User Instructions:</b>	Section 6033
<b>Battery Cabinet Spec. No. 545506 Installation and User Instructions:</b>	Section 6036
<b>Rectifier User Instructions:</b>	UM1R481000
<b>NCU Controller User Instructions:</b>	UM1M830BNA
<b>ACU+ Controller User Instructions:</b>	UM1M820BNA
<b>SCU+ Controller User Instructions:</b>	UM1M521BNA

**Vertiv.com | Vertiv Headquarters, 1050 Dearborn Drive, Columbus, OH, 43085, USA**

© 2022 Vertiv Group Corp. All rights reserved. Vertiv™ and the Vertiv logo are trademarks or registered trademarks of Vertiv Group Corp. All other names and logos referred to are trade names, trademarks or registered trademarks of their respective owners. While every precaution has been taken to ensure accuracy and completeness here, Vertiv Group Corp. assumes no responsibility, and disclaims all liability, for damages resulting from use of this information or for any errors or omissions. Specifications, rebates and other promotional offers are subject to change at Vertiv's sole discretion upon notice.