



# NetSure™

-48 VDC Power System

Quick Start Guide (QS582137000), Revision K

Specification Number: 582137000

Model Number: 512NGBB

This document may contain confidential and/or proprietary information of Vertiv Group Corp., and its receipt or possession does not convey any right to reproduce, disclose its contents, or to manufacture or sell anything that it may describe. Reproduction, disclosure, or use without specific authorization from Vertiv Group Corp. is strictly prohibited.

© 2020 Vertiv Group Corp. All rights reserved. Vertiv™ and the Vertiv logo are trademarks or registered trademarks of Vertiv Group Corp. All other names and logos referred to are trade names, trademarks or registered trademarks of their respective owners. While every precaution has been taken to ensure accuracy and completeness herein, Vertiv Group Corp. assumes no responsibility, and disclaims all liability, for damages resulting from use of this information or for any errors or omissions. Specifications are subject to change without notice.

# TABLE OF CONTENTS

<b>Admonishments Used in this Document.....</b>	<b>5</b>
<b>Important Safety Instructions .....</b>	<b>6</b>
General Safety .....	6
Voltages .....	6
AC Input Voltages.....	6
DC Output and Battery Voltages .....	6
Battery .....	7
Personal Protective Equipment (PPE).....	8
Hazardous Voltage.....	8
Handling Equipment Containing Static Sensitive Components.....	8
Maintenance and Replacement Procedures.....	8
<b>Static Warning.....</b>	<b>9</b>
<b>Customer Documentation Package.....</b>	<b>11</b>
<b>Physical Installation.....</b>	<b>11</b>
<b>Installing Circuit Breakers and Fuses.....</b>	<b>12</b>
<b>Install and Wire Transient Voltage Surge Suppressor (TVSS) Devices .....</b>	<b>15</b>
<b>Electrical Connections .....</b>	<b>16</b>
Important Safety Instructions .....	16
Relay Rack / Cabinet Frame Grounding Connection.....	16
Central Office Ground Connection .....	16
Ground Connection to a Transient Voltage Surge Suppressor (TVSS) Devices .....	16
AC Input and AC Input Equipment Grounding Connections to 588705300 Module Mounting Shelf(s).....	16
External Alarm, Reference, Monitoring, and Control Connections .....	18
Circuit Card and Connector Locations.....	18
System Interface Circuit Card Connections (if required) (List 27 Distribution Cabinet Only).....	20
IB2 (Controller Interface Board) Connections (if required).....	21
EIB (Controller Extended Interface Board) Connections (if required).....	26
Controller Ethernet Connection (if required).....	32
Connecting a Device or System to the Controller’s CAN Bus (List 27 Distribution Cabinet Only).....	33
Load Connections to a List 27 Distribution Cabinet .....	34
Load Connections to a List 7 Distribution Cabinet .....	41
Battery Connections to a List 27 Distribution Cabinet .....	43
Battery Connections to a List 7 Distribution Cabinet .....	44
<b>Installing Rectifier and Converter Modules .....</b>	<b>45</b>
General.....	45
System with List 7 Distribution Cabinet .....	45
System with List 27 Distribution Cabinet .....	45

Installing Rectifier and Converter Modules.....	45
<b>Initially Starting, Configuring, and Checking System Operation.....</b>	<b>48</b>
Important Safety Instructions .....	48
Initial Startup Preparation.....	48
Initially Starting the System.....	48
NCU Controller Procedure.....	48
ACU+ Controller Procedure.....	55

## ADMONISHMENTS USED IN THIS DOCUMENT



**DANGER!** Warns of a hazard the reader *will* be exposed to that will *likely* result in death or serious injury if not avoided. (ANSI, OSHA)



**WARNING!** Warns of a potential hazard the reader *may* be exposed to that *could* result in death or serious injury if not avoided. This admonition is not used for situations that pose a risk only to equipment, software, data, or service. (ANSI)



**CAUTION!** Warns of a potential hazard the reader *may* be exposed to that *could* result in minor or moderate injury if not avoided. (ANSI, OSHA) This admonition is not used for situations that pose a risk only to equipment, data, or service, even if such use appears to be permitted in some of the applicable standards. (OSHA)



**ALERT!** Alerts the reader to an action that *must be avoided* in order to protect equipment, software, data, or service. (ISO)



**ALERT!** Alerts the reader to an action that *must be performed* in order to prevent equipment damage, software corruption, data loss, or service interruption. (ISO)



**FIRE SAFETY!** Informs the reader of fire safety information, reminders, precautions, or policies, or of the locations of fire-fighting and fire-safety equipment. (ISO)



**SAFETY!** Informs the reader of general safety information, reminders, precautions, or policies not related to a particular source of hazard or to fire safety. (ISO, ANSI, OSHA)

# IMPORTANT SAFETY INSTRUCTIONS

## General Safety



**DANGER!** YOU MUST FOLLOW APPROVED SAFETY PROCEDURES.

Performing the following procedures may expose you to hazards. These procedures should be performed by qualified technicians familiar with the hazards associated with this type of equipment. These hazards may include shock, energy, and/or burns. To avoid these hazards:

- a) The tasks should be performed in the order indicated.
- b) Remove watches, rings, and other metal objects.
- c) Prior to contacting any uninsulated surface or termination, use a voltmeter to verify that no voltage or the expected voltage is present. Check for voltage with both AC and DC voltmeters prior to making contact.
- d) Wear eye protection.
- e) Use certified and well maintained insulated tools. Use double insulated tools appropriately rated for the work to be performed.

## Voltages

### AC Input Voltages



**DANGER!** This system operates from AC input voltage capable of producing fatal electrical shock. AC input power must be completely disconnected from the branch circuits wiring used to provide power to the system before any AC electrical connections are made. Follow local lockout/tagout procedures to ensure upstream branch circuit breakers remain de-energized during installation. DO NOT apply AC input power to the system until all electrical connections have been completed and checked.

### DC Output and Battery Voltages



**DANGER!** This system produces DC power and may have a battery source connected to it. Although the DC voltage is not hazardously high, the rectifiers and/or battery can deliver large amounts of current. Exercise extreme caution not to inadvertently contact or have any tool inadvertently contact an output terminal or battery terminal or exposed wire connected to an output terminal or battery terminal. NEVER allow a metal object, such as a tool, to contact more than one termination or battery terminal at a time, or to simultaneously contact a termination or battery terminal and a grounded object. Even a momentary short circuit can cause sparking, explosion, and injury.



**DANGER!** Follow local lockout/tagout procedures to ensure DC branch circuit protection devices remain de-energized during installation at loads, as required.

## Battery

Refer to the battery manufacturer documentation for specific battery safety instructions. The following are general guidelines.



**WARNING!** Correct polarity must be observed when connecting battery leads.



**WARNING!** Special safety precautions are required for procedures involving handling, installing, and servicing batteries. Observe all battery safety precautions in this manual and in the battery instruction manual. These precautions should be followed implicitly at all times.



**WARNING!** A battery can present a risk of electrical shock and high short circuit current. Servicing of batteries should be performed or supervised only by properly trained and qualified personnel knowledgeable about batteries and the required precautions.

The following precautions should be observed when working on batteries:

- Remove watches, rings, and other metal objects.
- Eye protection should be worn to prevent injury from accidental electrical arcs.
- Use certified and well maintained insulated tools. Use double insulated tools appropriately rated for the work to be performed. Ensure that wrenches with more than one working end have only one end exposed.
- Do not lay tools or metal parts on top of batteries.
- Disconnect charging source prior to connecting or disconnecting battery terminals.
- Risk of explosion if battery is replaced with an incorrect type or if polarity is reversed. Recommended to replace batteries with the same manufacturer and type, or equivalent.
- Dispose of used batteries according to the instructions provided with the batteries. Do not dispose of batteries in a fire. They may explode.
- ALWAYS FOLLOW THE BATTERY MANUFACTURER'S RECOMMENDATIONS AND SAFETY INSTRUCTIONS.



**DANGER!** This equipment may be used in conjunction with lead-acid batteries. Working near lead-acid batteries is dangerous!

In addition to the hazard of electric shock, gas produced by batteries can be explosive and sulfuric acid can cause severe burns.

- Do not open or mutilate batteries. Released electrolyte is harmful to the skin and eyes, and is toxic.
- Batteries contain sulfuric acid.
- Batteries generate explosive gases during normal operation. Systems containing batteries should never be installed in an airtight room or space. Only install in a ventilated environment.
- Batteries are an energy source that can produce high amounts of electrical current.

FOR THESE REASONS, IT IS OF CRITICAL IMPORTANCE THAT YOU READ THESE INSTRUCTIONS AND FOLLOW THEM EXACTLY.

WHEN WORKING WITH LEAD-ACID BATTERIES:

- Follow the recommended PPE requirements per the SDS for the battery to be used.
- If battery acid enters your eye, immediately flush your eye with running cold water for at least 15 minutes. Get medical attention immediately.
- If battery acid contacts skin or clothing, wash immediately with soap and water.



**ALERT!** Performing maintenance and/or troubleshooting procedures may interrupt power to the loads, if battery reserve is not sufficient.

### Personal Protective Equipment (PPE)



**DANGER!** ARC FLASH AND SHOCK HAZARD.

Appropriate PPE and tools required when working on this equipment. An appropriate flash protection boundary analysis should be done determine the “hazard/risk” category, and to select proper PPE.



This product is intended only for installation in a Restricted Access Location.

Only authorized and properly trained personnel should be allowed to install, inspect, operate, or maintain the equipment.

Do not work on LIVE parts. If required to work or operate live parts, obtain appropriate Energized Work Permits as required by the local authority, per NFPA 70E “Standard for Electrical Safety in the Workplace”.

### Hazardous Voltage



**DANGER!** HAZARD OF ELECTRICAL SHOCK.

More than one disconnect may be required to de-energize the system before servicing.

### Handling Equipment Containing Static Sensitive Components



**ALERT!** Installation or removal of equipment containing static sensitive components requires careful handling. Before handling any equipment containing static sensitive components, read and follow the instructions contained on the Static Warning Page.

### Maintenance and Replacement Procedures



**CAUTION!** When performing any step in procedures that requires removal or installation of hardware, use caution to ensure no hardware is dropped and left inside the unit; otherwise service interruption or equipment damage may occur.



**NOTE!** When performing any step in procedures that requires removal of existing hardware, retain all hardware for use in subsequent steps, unless otherwise directed.



## STATIC WARNING



This equipment contains static sensitive components. The warnings listed below must be observed to prevent damage to these components. Disregarding any of these warnings may result in personal injury or damage to the equipment.

1. Strictly adhere to the procedures provided in this document.
2. Before touching any equipment containing static sensitive components, discharge all static electricity from yourself by wearing a wrist strap grounded through a one megohm resistor. Some wrist straps have a built-in one megohm resistor; no external resistor is necessary. Read and follow wrist strap manufacturer's instructions outlining use of a specific wrist strap.
3. Do not touch traces or components on equipment containing static sensitive components. Handle equipment containing static sensitive components only by the edges that do not have connector pads.
4. After removing equipment containing static sensitive components, place the equipment only on static dissipative surfaces such as conductive foam or ESD bag. Do not use ordinary Styrofoam or ordinary plastic.
5. Store and ship equipment containing static sensitive components only in static shielding containers.
6. If necessary to repair equipment containing static sensitive components, wear an appropriately grounded wrist strap, work on a conductive surface, use a grounded soldering iron, and use grounded test equipment.

This page is intentionally blank.

# CUSTOMER DOCUMENTATION PACKAGE

This document (QS582137000) provides *Quick Start Instructions* for NetSure™ -48 VDC Power System Model 512NGBB, Spec. No. 582137000.

The complete Customer Documentation Package consists of...

## **NetSure™ -48 VDC Power System Installation Manual**

- Power System Installation Instructions: IM582137000
- Power System Quick Start Guide: QS582137000

## **NetSure™ NCU Controller User Manual**

- NCU Controller User Instructions: UM1M830BNA

## **NetSure™ ACU+ Controller User Manual**

- ACU+ Controller User Instructions: UM1M820BNA

## **USB Drive with All Customer Documentation**

- Power System Quick Start Guide: QS582137000
- Power System Installation Instructions: IM582137000
- Power System User Instructions: UM582137000
- NCU Controller User Instructions: UM1M830BNA
- ACU+ Controller User Instructions: UM1M820BNA
- Rectifier Instructions: UM1R482000E3
- Converter Instructions: UM1C48241500
- Power System “System Application Guide”: SAG582137000
- Module Mounting Shelf Power Data Sheet: PD588705300
- Engineering Drawings
- Also provided on the USB drive is a controller configuration drawing and the controller configuration files loaded into the controller as shipped.

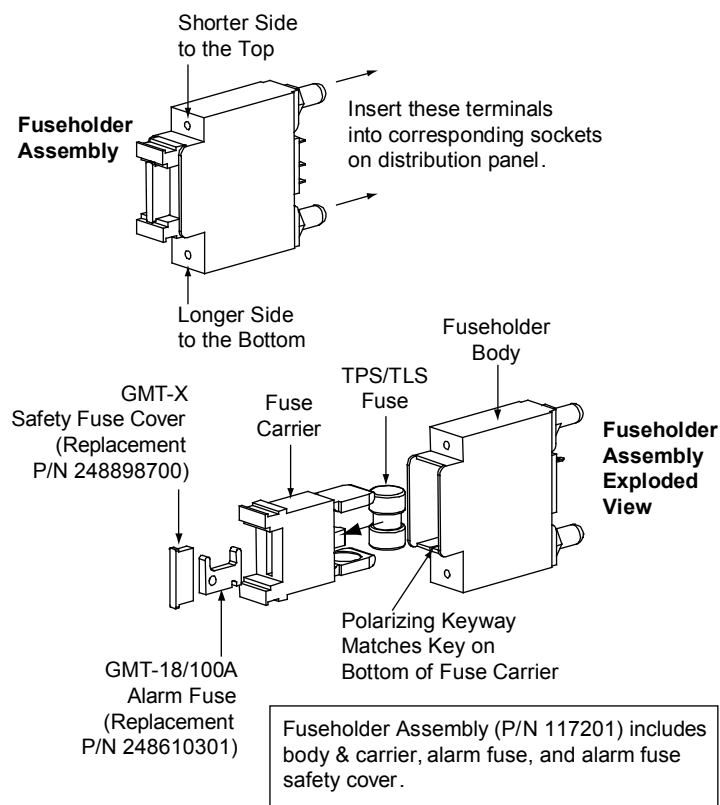
# PHYSICAL INSTALLATION

To do this...	See this in the <i>Installation Instructions</i> (IM582137000)
<b>Choose a mounting location</b>	<i>General Requirements</i> in the INSTALLING THE SYSTEM section.
<b>Mount the Power System</b>	<i>Mounting the System in an Equipment Rack</i> in the INSTALLING THE SYSTEM section.
<b>Install optional lug adapter busbar kits</b>	<i>Installing Optional Lug Adapter Busbar Kits</i> in the INSTALLING THE SYSTEM section.

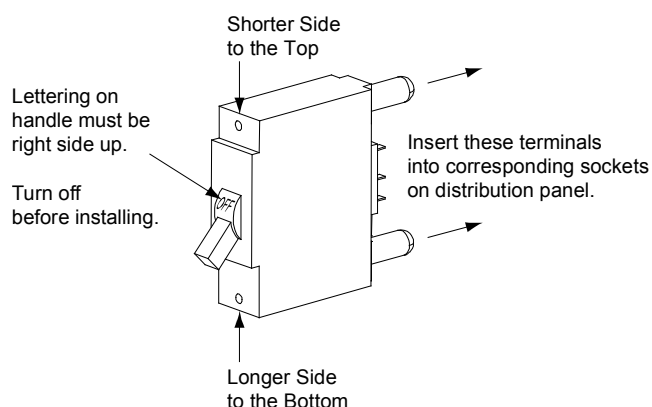
# INSTALLING CIRCUIT BREAKERS AND FUSES

Load and battery distribution devices were factory-installed if ordered with the power system. If additional installation is required, refer to **Figure 1** through **Figure 4**. For detailed procedures, refer to *Installing Circuit Breakers and Fuses* in the INSTALLING THE SYSTEM section of the Installation Instructions (IM582137000).

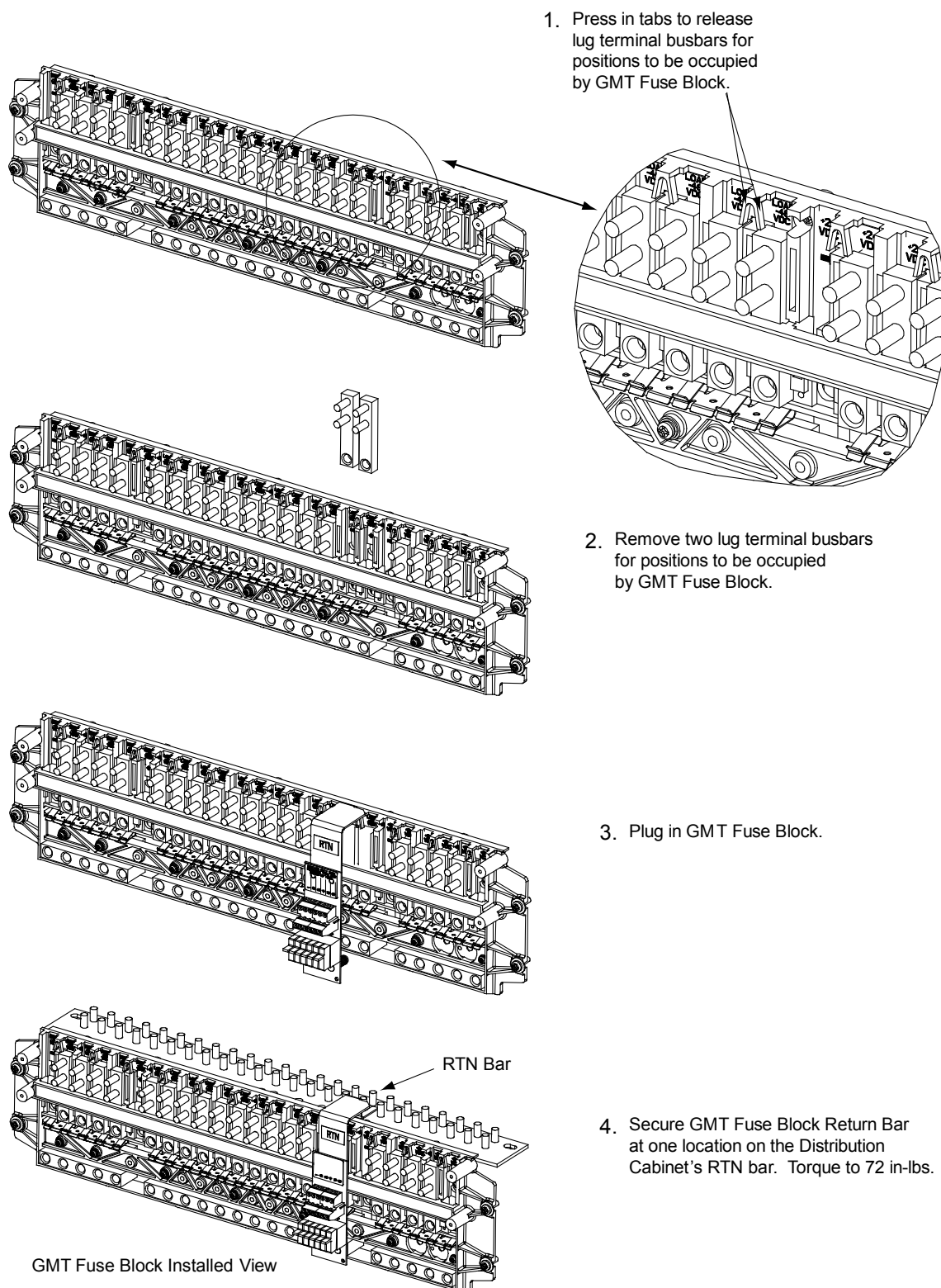
**Figure 1:** Installing a Bullet Nose Type Fuseholder and TPS/TLS Fuse



**Figure 2:** Installing a Bullet Nose Type Circuit Breaker

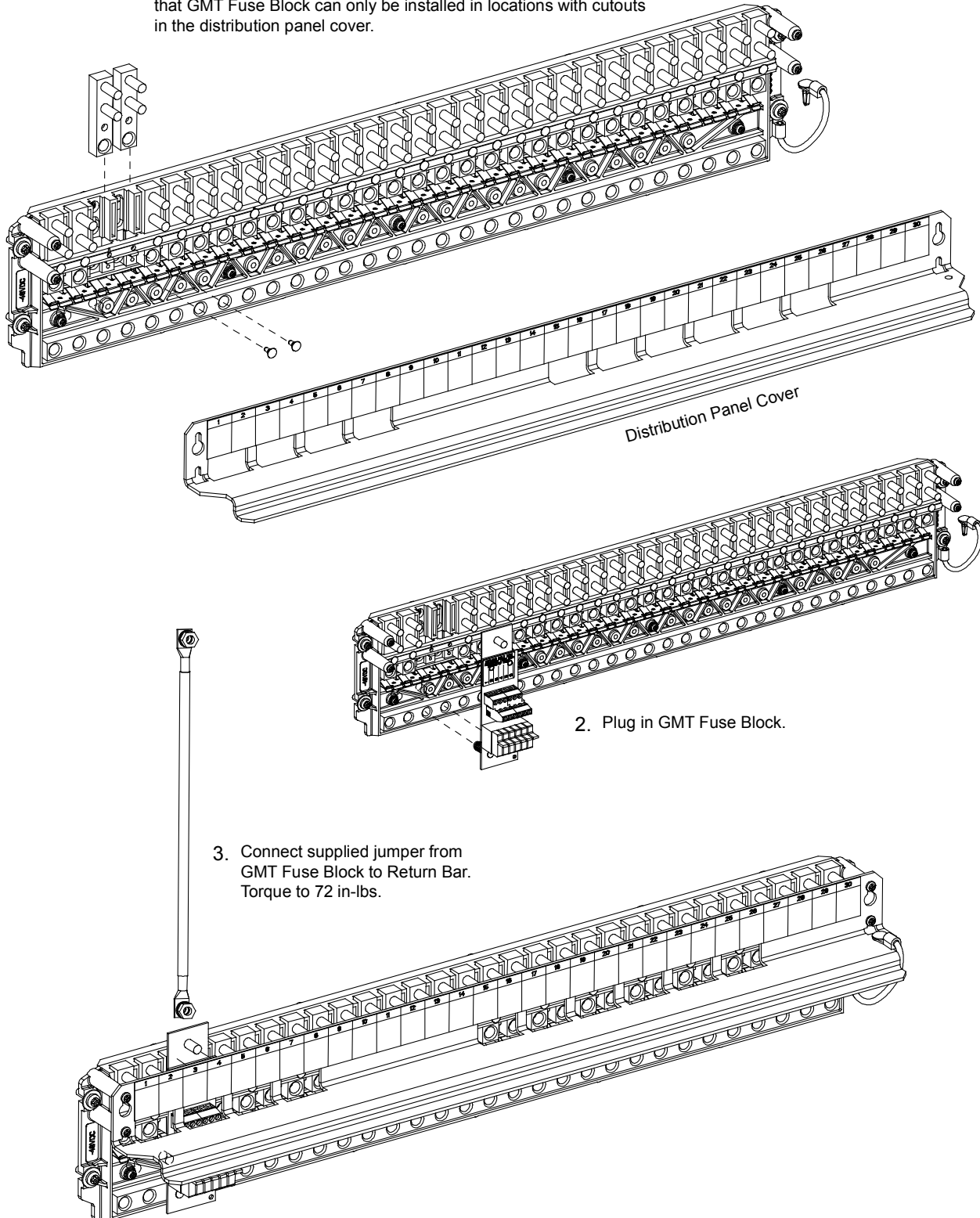


**Figure 3:** Installing an Optional Bullet Nose Type 6-Position GMT Distribution Fuse Block (P/N 545333) in a List 7 Distribution Cabinet



**Figure 4:** Installing an Optional Bullet Nose Type 6-Position GMT Distribution Fuse Block (P/N 549017) in a List 27 Distribution Cabinet

1. Remove two lug terminal busbars for positions to be occupied by GMT Fuse Block. Remove plastic busbar plugs first. Note that GMT Fuse Block can only be installed in locations with cutouts in the distribution panel cover.

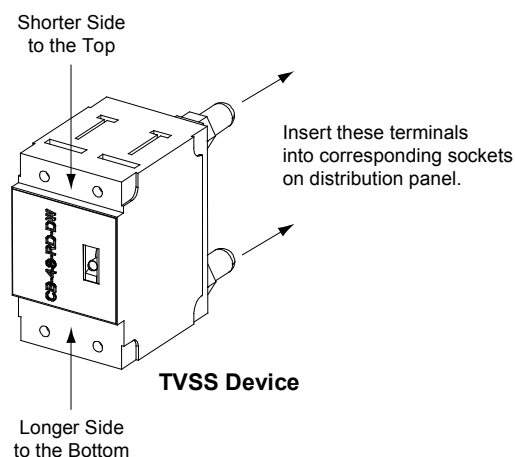


# INSTALL AND WIRE TRANSIENT VOLTAGE SURGE SUPPRESSOR (TVSS) DEVICES

Transient Voltage Surge Suppressor (TVSS) devices were factory-installed if ordered with the power system. If additional installation is required, refer to **Figure 5**. For detailed procedures, refer to *Installation and Wiring of a Transient Voltage Surge Suppressor (TVSS) Device* in the INSTALLING THE SYSTEM section of the Installation Instructions (IM582137000).

**NOTE!** The Transient Voltage Surge Suppressor (TVSS) device is to be installed on the -48V distribution bus only.

**Figure 5:** Installation and Wiring of Transient Voltage Surge Suppressor (TVSS) Devices

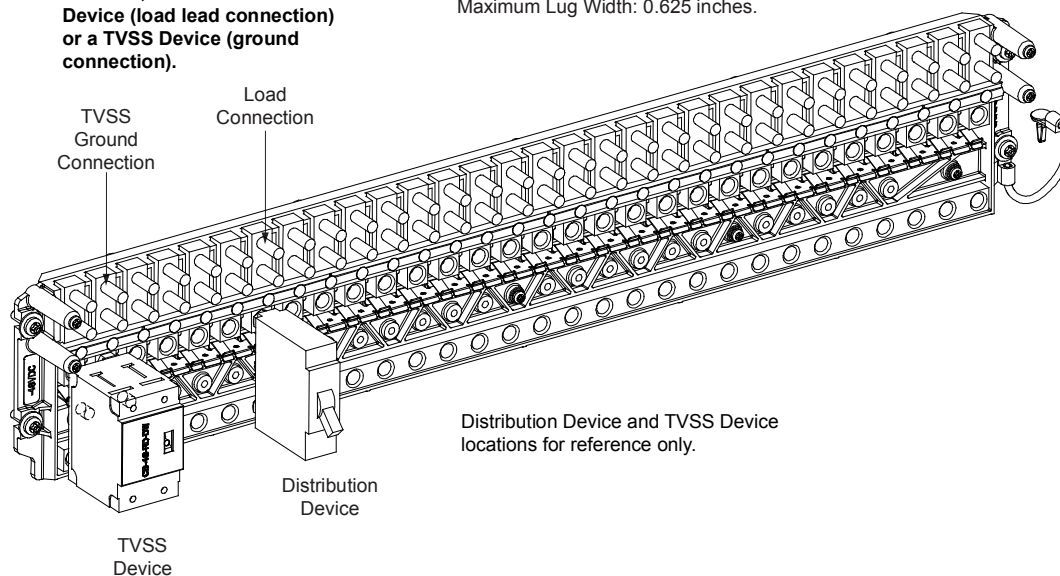


**DANGER**

Ensure leads are connected to proper polarity for the device installed, either a Distribution Device (load lead connection) or a TVSS Device (ground connection).

1/4-20 Studs on 5/8" Centers  
(Customer must supply or order hardware)

Maximum Lug Width: 0.625 inches.



# ELECTRICAL CONNECTIONS

## Important Safety Instructions



**DANGER!** Adhere to the “Important Safety Instructions” presented at the front of this document.

## Relay Rack / Cabinet Frame Grounding Connection

For relay rack / cabinet grounding requirements, refer to the current edition of the American National Standards Institute (ANSI) approved National Fire Protection Association's (NFPA) National Electrical Code (NEC), applicable local codes, and your specific site requirements.

## Central Office Ground Connection

Landing points are provided on the battery return bus for a central office ground lead (see **Figure 25** or **Figure 26**). For central office grounding requirements, refer to the current edition of the American National Standards Institute (ANSI) approved National Fire Protection Association's (NFPA) National Electrical Code (NEC), applicable local codes, and your specific site requirements.

## Ground Connection to a Transient Voltage Surge Suppressor (TVSS) Devices

Refer to the procedure in “Install and Wire Transient Voltage Surge Suppressor (TVSS) Devices” on page 15.

## AC Input and AC Input Equipment Grounding Connections to 588705300 Module Mounting Shelf(s)

Refer to *AC Input and AC Input Equipment Grounding Connections to 588705300 Module Mounting Shelf(s)* in MAKING ELECTRICAL CONNECTIONS section of the Installation Instructions (IM582137000) for a complete procedure.



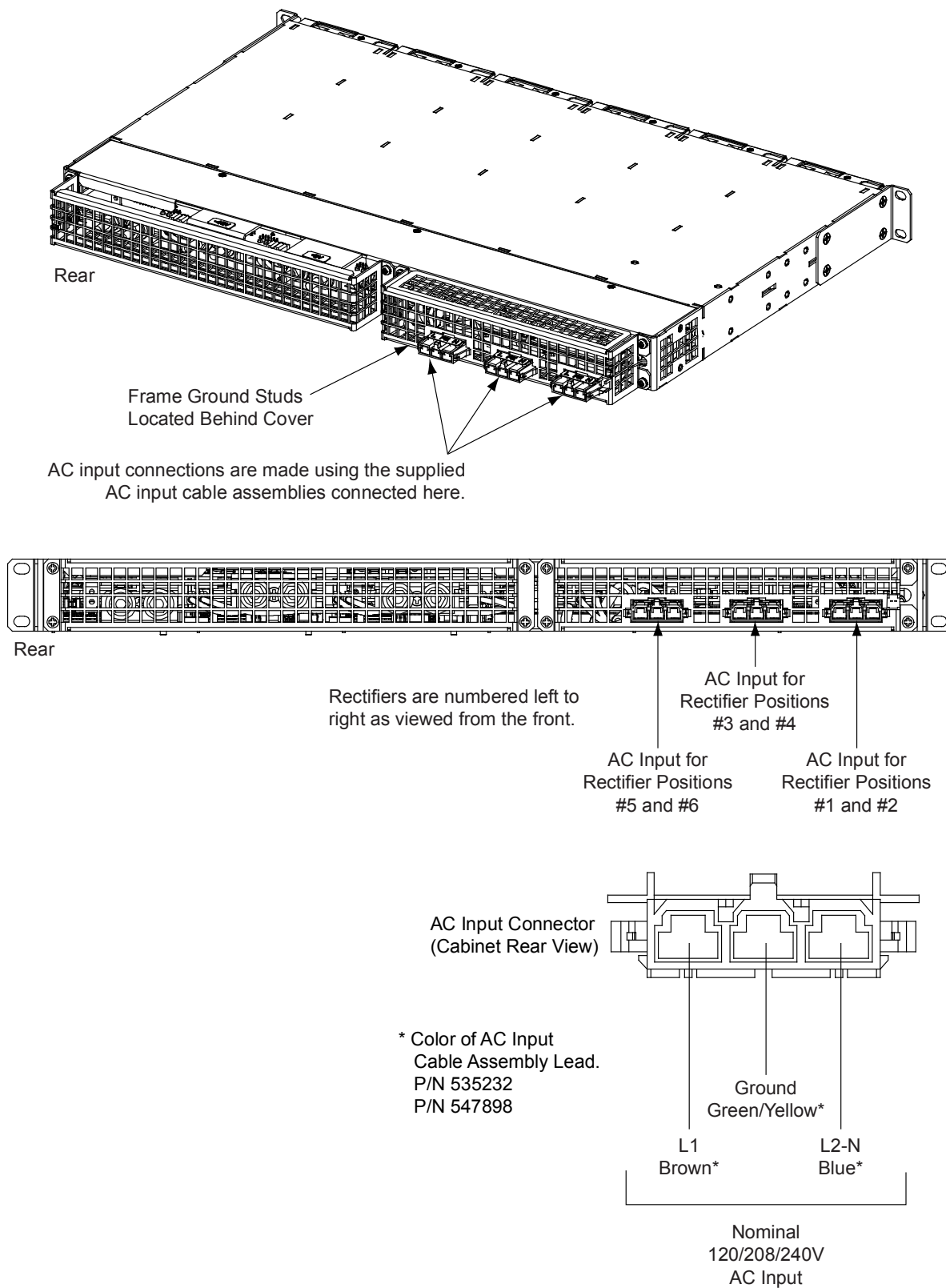
**DANGER!** Adhere to the “Important Safety Instructions” presented at the front of this document.

There are several options to provide AC inputs to the 588705300 module mounting shelf. See PD588705300.

1. For factory installed module mounting shelves without plug-in AC input connectors, AC input leads are factory connected from the module mounting shelf AC input terminals to an AC input termination assembly provided in the system/cabinet. Refer to the system/cabinet documentation for connection details to the AC input termination assembly. Refer to the system/cabinet documentation for recommended AC input branch circuit protection.
2. For a field installed module mounting shelf in a system with a List 27 distribution cabinet or if a List 7 distribution cabinet system is used in a relay rack and not a system cabinet, the module mounting shelf is equipped with plug-in AC input connectors located on the rear of the shelf. AC input cable assemblies with mating connectors are available (see Power Data Sheet PD588705300). Refer to Power Data Sheet PD588705300 for recommended AC input branch circuit protection. See PD588705300 and **Figure 6**.



**Figure 6:** AC Input Connections to Module Mounting Shelf with Plug-In AC Input Connectors



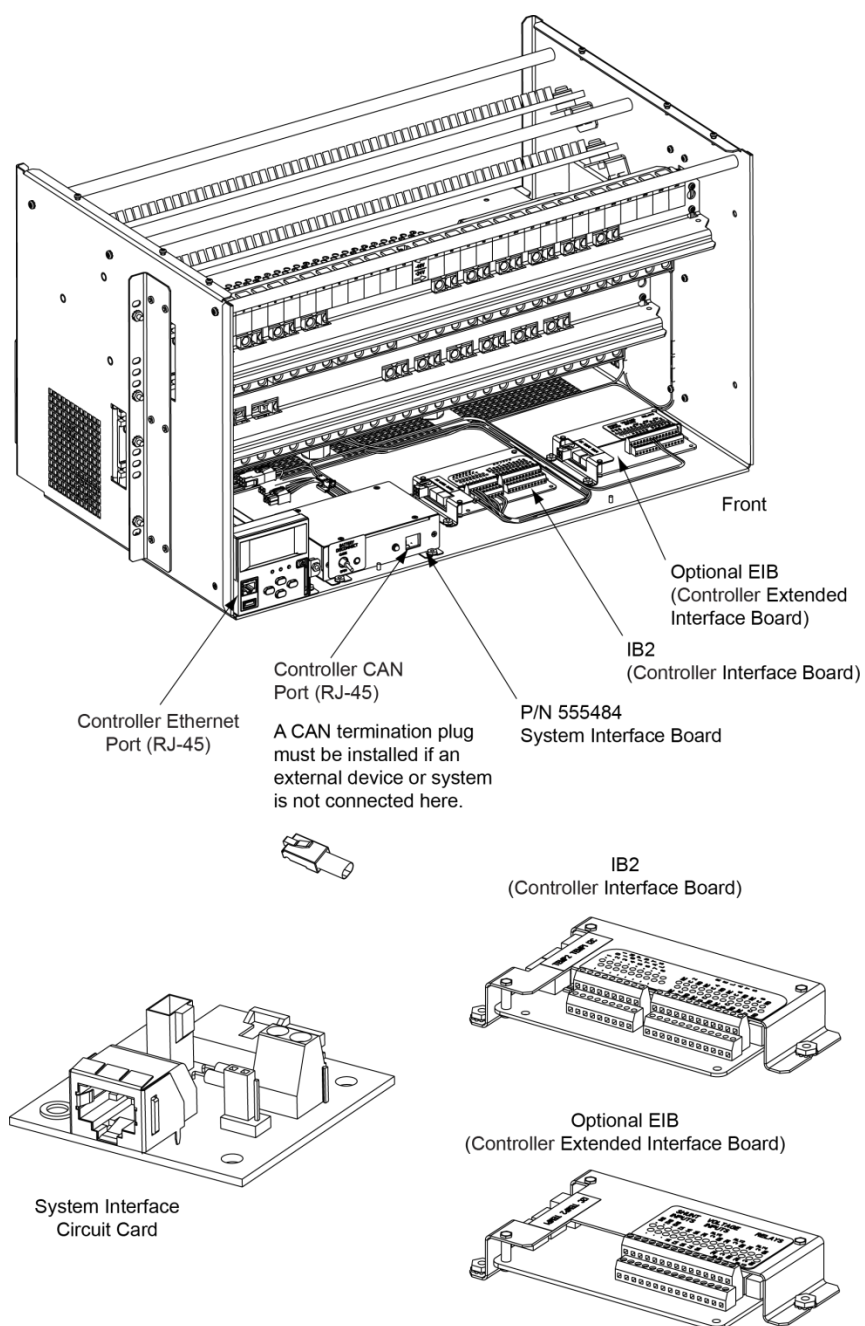
## External Alarm, Reference, Monitoring, and Control Connections

Refer to *External Alarm, Reference, Monitoring, and Control Connections* in MAKING ELECTRICAL CONNECTIONS section of the Installation Instructions (IM582137000) for complete procedures.

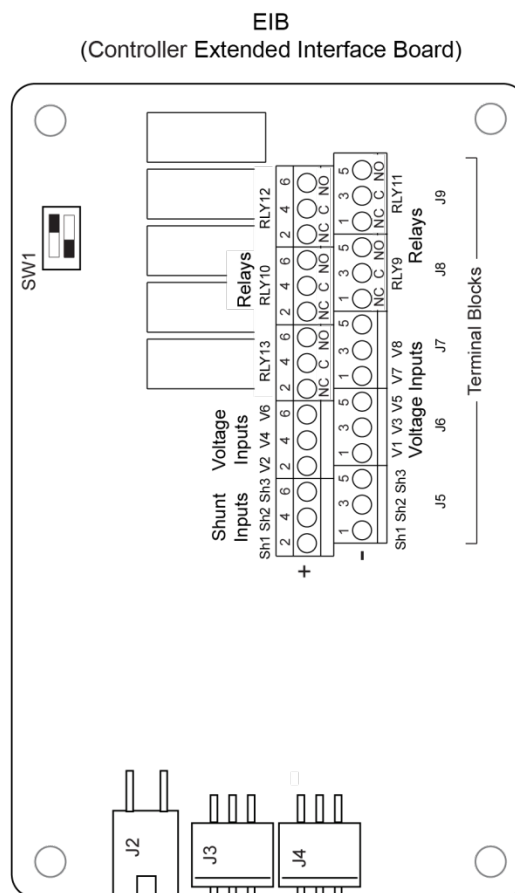
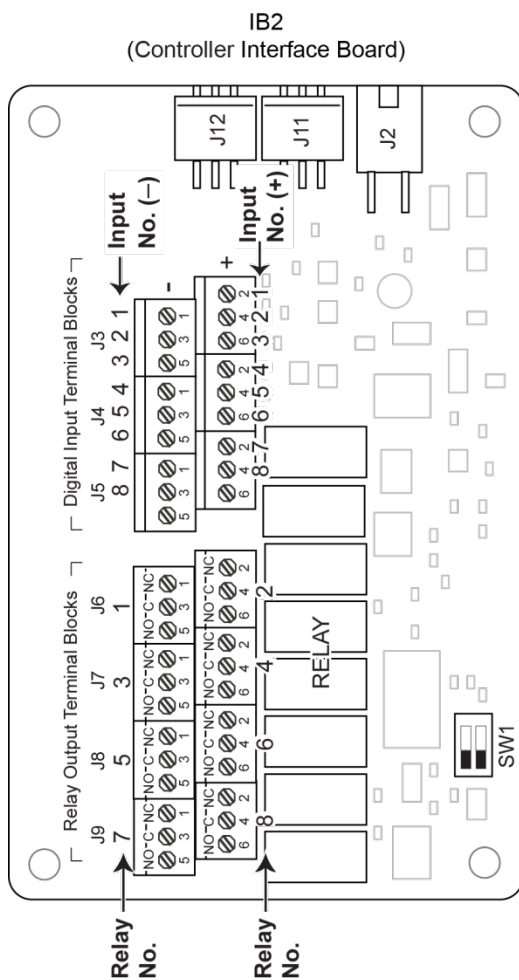
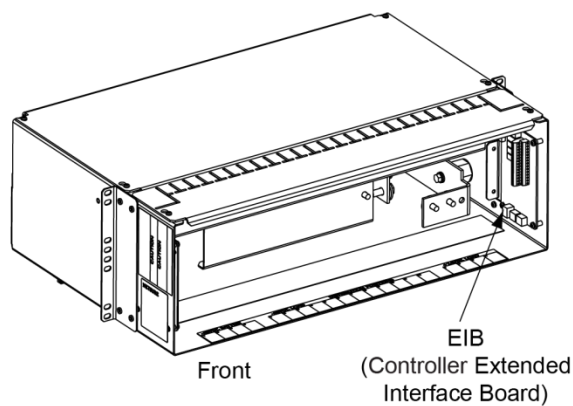
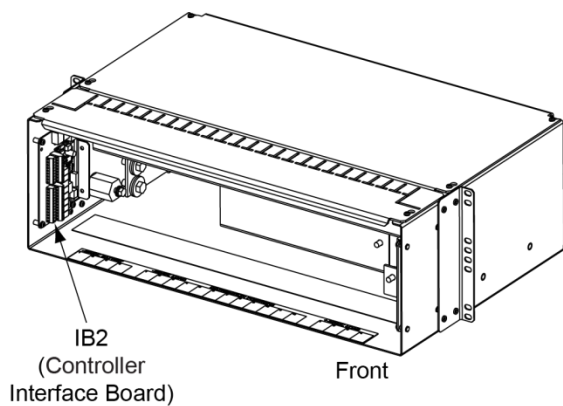
### Circuit Card and Connector Locations

Refer to **Figure 7** or **Figure 8**.

**Figure 7:** Circuit Card and Connector Locations - List 27 Distribution Cabinet



**Figure 8:** Circuit Card and Connector Locations - List 7 Distribution Cabinet

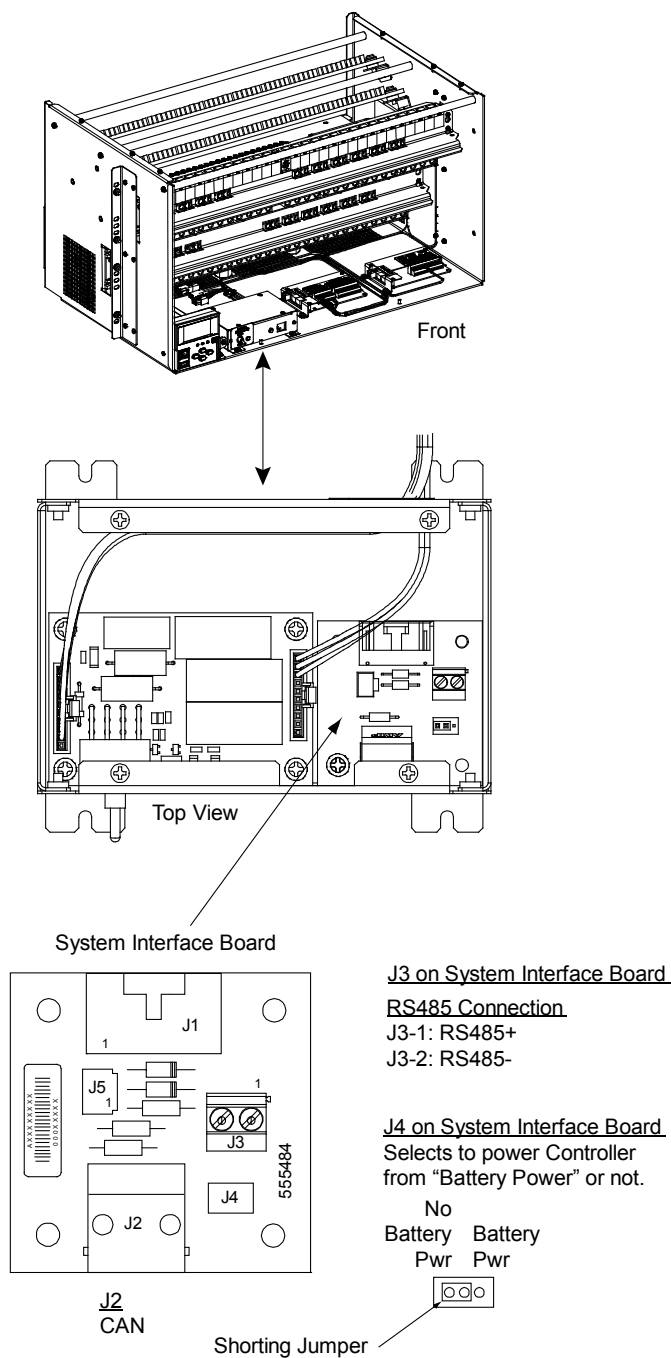


### System Interface Circuit Card Connections (if required) (List 27 Distribution Cabinet Only)

The System Interface Circuit Card provides connections for the following. Refer to **Figure 7** for circuit card location. Refer to **Figure 9** for connections location.

- RS-485 (used for communication with SM modules)

**Figure 9:** System Interface Circuit Card Connections



## **IB2 (Controller Interface Board) Connections (if required)**

The IB2 (Controller Interface Board) provides connection points for digital inputs, programmable relay outputs, and temperature probes. The IB2 interface board is mounted inside the distribution cabinet. Refer to **Figure 7** or **Figure 8**.

### **Digital Inputs and Programmable Relay Outputs**

Digital input and relay output leads are connected to screw-type terminal blocks located on the IB2. Recommended torque for these connections is 2.2 in-lbs. Refer to **Figure 10** for terminal locations. Refer to **Table 1** and **Table 2** for pin-out information.

#### **Digital Inputs**

Connect up to eight (8) digital inputs to the IB2. Note that you must supply both paths for the digital input (either a positive or negative signal and the opposite polarity return path). Observe proper polarity. Refer to **Figure 10** for terminal locations and **Table 1** for pin-out information.

The digital inputs can be programmed to provide an alarm when the signal is applied (HIGH) or removed (LOW). Refer to the Controller Instructions (UM1M820BNA or UM1M830BNA) for programming information.

Digital Input Ratings: Refer to the following.

- a) Maximum Voltage Rating: 60 VDC.
- b) Active High: > 19 VDC.
- c) Active Low: < 1 VDC.


The digital inputs may be preprogrammed for specific functions. Refer to the configuration drawing (C-drawing) supplied with your system for your system's specific configuration.

#### **ESTOP Function**

If an ESTOP switch is wired to the IB2-1 Controller Interface Board, customer-furnished system ground applied to terminal DI8+ activates the ESTOP function. The ESTOP function shuts down and locks out the rectifiers, shuts down and locks out the optional -48 VDC to +24 VDC converters, and opens the optional low voltage disconnect (LVD) contactors (battery and load type). If the system has battery connected and does not contain a battery LVD or the controller power option is set to Battery Pwr (jumper J4 on the system interface board is set to Battery Pwr), the controller will remain operational. If the system does not contain battery or load LVD(s) and has battery connected, the loads will be sustained by the battery voltage.

For Systems NOT Containing a Battery LVD: When the ESTOP signal is removed, LVD contactors (battery and load type) will close after the "LVD Reconnect Delay" has elapse (customer configurable via the controller) if battery voltage is present on the bus. Rectifiers and -48 VDC to +24 VDC converters will remain off. The rectifiers will restart when the input power is removed and restored after 30 seconds or more (until the LEDs on the modules extinguish). To restart the -48 VDC to +24 VDC converters: remove the converter, wait 30 seconds or more (until the LEDs on the converter extinguish), then re-insert the converter.

For Systems Containing a Battery LVD: When the ESTOP signal is removed, LVD contactors (battery and load type) will remain open. Rectifiers and -48 VDC to +24 VDC converters will remain off. The rectifiers will restart when the input power is removed and restored after 30 seconds or more (until the LEDs on the modules extinguish). When the rectifiers restart, LVD contactors (battery and load type) will close after the "LVD Reconnect Delay" has elapse (customer configurable via the controller) and the -48 VDC to +24 VDC converters will restart.

 **NOTE!** If a customer-furnished method to disconnect the input power to the system is not provided, the rectifiers will stay locked OFF until the input power is recycled. If the ESTOP signal is removed without recycling the input power, the rectifiers will remain off and have a local alarm visible on the module. The ESTOP alarm from the controller will extinguish. The controller will not issue an alarm for this condition.

### **Programmable Relay Outputs**

The IB2 provides eight (8) programmable alarm relays with dry Form-C contacts. Connect up to eight (8) relay outputs to the IB2. Refer to **Figure 10** for terminal locations and **Table 2** for pin-out information.


Refer to the Controller Instructions (UM1M820BNA or UM1M830BNA) for programming information.

Relay Ratings: Refer to the following.

- a) Steady State: 0.5 A @ 60 VDC; 1.0 A @ 30 VDC.
- b) Peak: 3 A @ 30 VDC.

The relays may be preprogrammed for specific functions. Refer to the configuration drawing (C-drawing) supplied with your system for your system's specific configuration.

### **Temperature Probes**

 **NOTE!** Each temperature probe consists of two or three pieces that plug together to make a complete probe. See SAG582137000 for part numbers and descriptions.

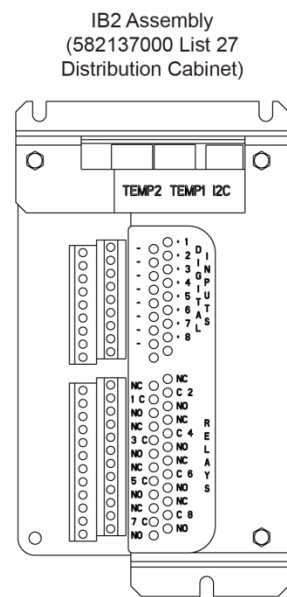
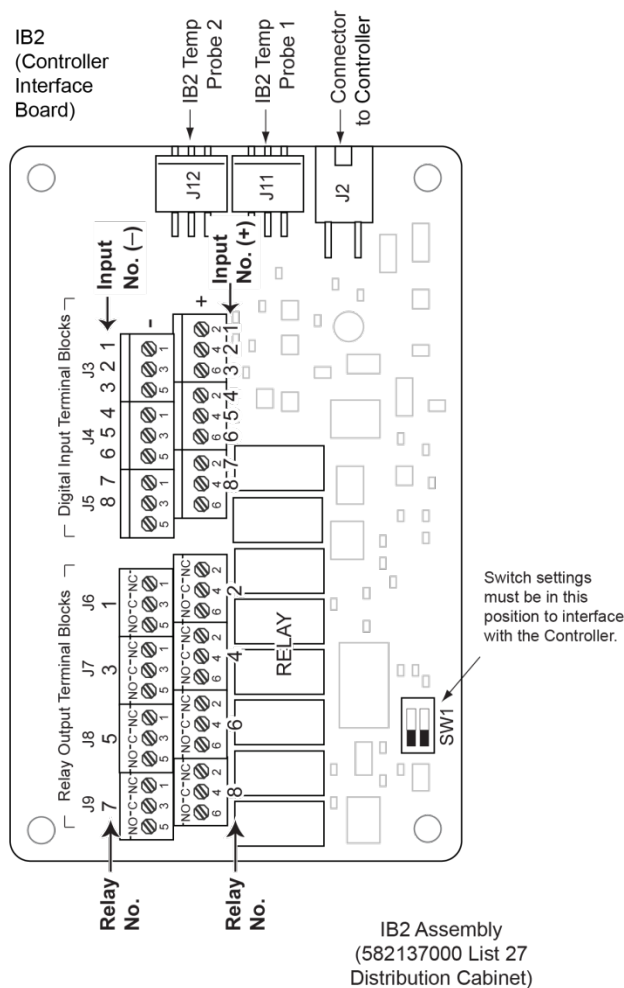
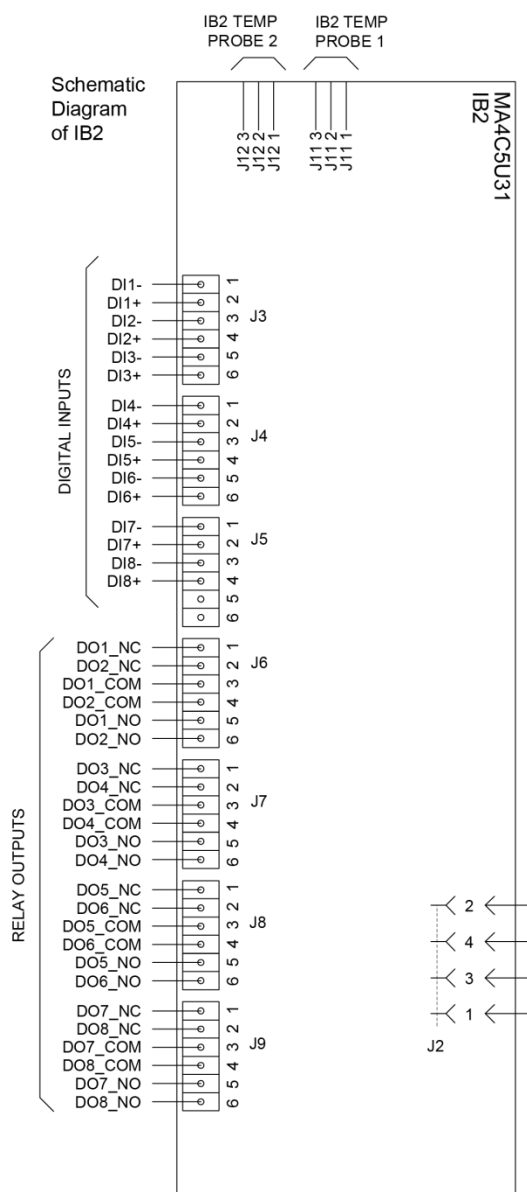
Temperature probes are connected to the IB2 (Controller Interface Board) and/or EIB (Controller Extended Interface Board) mounted inside the distribution cabinet.

Up to two (2) temperature probes can be connected to the IB2. Up to two (2) additional temperature probes can be connected to the EIB. Any combination of the four (4) temperature probes can be programmed to monitor ambient temperature and/or battery temperature. A temperature probe set to monitor battery temperature can also be used for the rectifier battery charge temperature compensation feature, or the battery charge temperature compensation feature can be programmed to use the average or highest value of all battery temperature probes. The battery charge temperature compensation feature allows the controller to automatically increase or decrease the output voltage of the system to maintain battery float current as battery temperature decreases or increases, respectively. Battery life can be extended when an optimum charge voltage to the battery with respect to temperature is maintained. A temperature probe set to monitor battery temperature can also be used for the BTRM (Battery Thermal Runaway Management) feature. The BTRM feature lowers output voltage when a high temperature condition exists to control against battery thermal runaway.

The temperature sensor end of the probe contains a tab with a 5/16" clearance hole for mounting.

A temperature probe programmed to monitor battery temperature should be mounted on the negative post of a battery cell to sense battery temperature. A temperature probe used for battery charge temperature compensation and/or BTRM (Battery Thermal Runaway Management) should also be mounted on the negative post of a battery cell. A temperature probe programmed to monitor ambient temperature should be mounted in a convenient location, away from direct sources of heat or cold.

**Figure 10: IB2 (Interface Board) Connections**



\* The controller's relay assigned to "Critical Summary" alarm (relay 1 by default) will operate in the "Fail Safe Mode". "Fail Safe Mode" means Relay 1 is de-energized during an alarm condition, opening the contacts between the C and NO terminals, and closing the contacts between the C and NC terminals.

The controller's remaining seven (7) relays energize during an alarm condition, closing the contacts between the C and NO terminals, and opening the contacts between the C and NC terminals.

Not all I/O points are available for customer connection (some are used for factory system connections).


**J3-J9:**

Wire Size Capacity: 16-26 AWG.

Recommended Torque: 2.2 in-lbs.

**Table 1:** Programmable Digital Inputs – IB2


Programmable Digital Input	IB2 Pin No.		Factory Wiring	Default Digital Input Function	Customer Defined Digital Input Function
1	J3-2	+	The digital inputs may be preprogrammed for specific functions and have factory wiring connected. Refer to the configuration drawing (C-drawing) supplied with your system for your system's specific configuration.	The digital inputs may be preprogrammed for specific functions. Refer to the configuration drawing (C-drawing) supplied with your system for your system's specific configuration.	
	J3-1	-			
2	J3-4	+			
	J3-3	-			
3	J3-6	+			
	J3-5	-			
4	J4-2	+			
	J4-1	-			
5	J4-4	+			
	J4-3	-			
6	J4-6	+			
	J4-5	-			
7	J5-2	+			
	J5-1	-			
8	J5-4	+	(to customer ESTOP switch)	ESTOP	
	J5-3	-	-48 VDC		
--	J5-5		not used	not used	not used
--	J5-6				

 **NOTE!** -48V is factory wired to the Digital Input #8 (-) terminal for your convenience and function predefined for ESTOP. Customer-furnished system ground applied to terminal Digital Input #8 (+) activates the ESTOP function. See “ESTOP Function” on page 21.



**Table 2:** Programmable Relay Outputs – IB2

Programmable Relay Output		IB2 Pin No.	Alarms Assigned to this Relay (Default)	Alarms Assigned to this Relay (Custom)							
1	NO	J6-5	The relays may be preprogrammed for specific functions. Refer to the configuration drawing (C-drawing) supplied with your system for your system's specific configuration.								
	COM	J6-3									
	NC	J6-1									
2	NO	J6-6		The relays may be preprogrammed for specific functions. Refer to the configuration drawing (C-drawing) supplied with your system for your system's specific configuration.							
	COM	J6-4									
	NC	J6-2									
3	NO	J7-5			The relays may be preprogrammed for specific functions. Refer to the configuration drawing (C-drawing) supplied with your system for your system's specific configuration.						
	COM	J7-3									
	NC	J7-1									
4	NO	J7-6				The relays may be preprogrammed for specific functions. Refer to the configuration drawing (C-drawing) supplied with your system for your system's specific configuration.					
	COM	J7-4									
	NC	J7-2									
5	NO	J8-5					The relays may be preprogrammed for specific functions. Refer to the configuration drawing (C-drawing) supplied with your system for your system's specific configuration.				
	COM	J8-3									
	NC	J8-1									
6	NO	J8-6						The relays may be preprogrammed for specific functions. Refer to the configuration drawing (C-drawing) supplied with your system for your system's specific configuration.			
	COM	J8-4									
	NC	J8-2									
7	NO	J9-5							The relays may be preprogrammed for specific functions. Refer to the configuration drawing (C-drawing) supplied with your system for your system's specific configuration.		
	COM	J9-3									
	NC	J9-1									
8	NO	J9-6								The relays may be preprogrammed for specific functions. Refer to the configuration drawing (C-drawing) supplied with your system for your system's specific configuration.	
	COM	J9-4									
	NC	J9-2									

 **NOTE!** The controller's relay assigned to "Critical Summary" alarm (relay 1 by default) will operate in the "Fail Safe Mode". "Fail Safe Mode" means Relay 1 is de-energized during an alarm condition, opening the contacts between the C and NO terminals, and closing the contacts between the C and NC terminals.

The controller's remaining 7 relays energize during an alarm condition, closing the contacts between the C and NO terminals, and opening the contacts between the C and NC terminals.

## EIB (Controller Extended Interface Board) Connections (if required)

The EIB (Controller Extended Interface Board) provides additional connection points for current and voltage inputs, programmable relay outputs, and temperature probes. The EIB extended interface board is mounted inside the distribution cabinet. Refer to **Figure 7** or **Figure 8**.

### Current Inputs, Voltage Inputs, and Programmable Relay Outputs

Current input, voltage input, and relay output leads are connected to screw-type terminal blocks located on the EIB. Recommended torque for these connections is 2.2 in-lbs. Refer to **Figure 12** for terminal locations. Refer to **Table 3**, **Table 4**, and **Table 5** for pin-out information.

#### Current Inputs

Connect up to three (3) shunt inputs to the EIB. Observe proper polarity. Refer to **Figure 12** for terminal locations and **Table 3** for pin-out information.

Refer to the Controller Instructions (UM1M820BNA or UM1M830BNA) and program the shunt input parameters found in the EIB menu.



**NOTE!** The shunt needs to be installed in the hot (-48V) bus. Connect the plus side of the shunt to the positive shunt input on the EIB. Connect the negative side of the shunt to the negative shunt input on the EIB.

### Voltage Inputs for Battery Block and Battery Midpoint Monitoring

The controller can monitor battery blocks (12V blocks) or midpoint battery voltage of battery strings connected to the EIB. The EIB provides a total of eight (8) DC voltage inputs for these connections. An alarm is issued when either battery block voltage or battery midpoint voltage is abnormal. Refer to **Figure 12** for terminal locations and **Table 4** for pin-out information.

Refer to **Figure 11** for connection details. Refer to the Controller Instructions (UM1M820BNA or UM1M830BNA) and program the following parameters.



**NOTE!** When using Battery Block Monitoring, you must make connections to all blocks.

- **Battery Block Monitoring**

Voltage Type: Set to “48 (Block 4)”. This selects the EIB to monitor up to two (2) 48V battery strings with four (4) 12V blocks per string.

BlockVDiff(12V): This menu item appears if “48 (Block 4)” is selected above. Set to the alarm threshold for battery block monitoring per site requirements. The controller issues an alarm when any block voltage of any battery string has an abnormal value. The alarm is issued when the difference between any block voltage and a reference voltage is greater than the value of the block voltage difference setting.

Block In-Use: Set to the number of 12V battery blocks being used.

- **Midpoint Monitoring**

Voltage Type: Set to “Midpoint”. This selects the EIB to monitor the midpoint voltage of up to eight (8) battery strings.

BlockVDiff(Mid): This menu item appears if “Midpoint” is selected above. Set to the alarm threshold for battery midpoint monitoring per site requirements. The controller issues an alarm when any battery

midpoint voltage of any battery string has an abnormal value. The alarm is issued when the difference between any battery midpoint voltage and a reference voltage is greater than the value of the block voltage difference setting.

Block In-Use: Set to number of 12V battery blocks being used.

### **Programmable Relay Outputs**

The EIB provides five (5) programmable alarm relays with dry Form-C contacts. Connect up to five (5) relay outputs to the IB2. Refer to **Figure 12** for terminal locations and **Table 4** for pin-out information.

Refer to the Controller Instructions (UM1M820BNA or UM1M830BNA) for programming information.

Relay Ratings: Refer to the following.

- a) Steady State: 0.5 A @ 60 VDC; 1.0 A @ 30 VDC.
- b) Peak: 3 A @ 30 VDC.

The relays may be preprogrammed for specific functions. Refer to the configuration drawing (C-drawing) supplied with your system for your system's specific configuration.

### **Temperature Probes**

Temperature probes can be connected to the EIB (Controller Extended Interface Board) mounted inside the distribution cabinet. Refer to "Temperature Probes" on page 22.

**Figure 11:** Sample Battery Block or Battery Midpoint Monitoring Connections

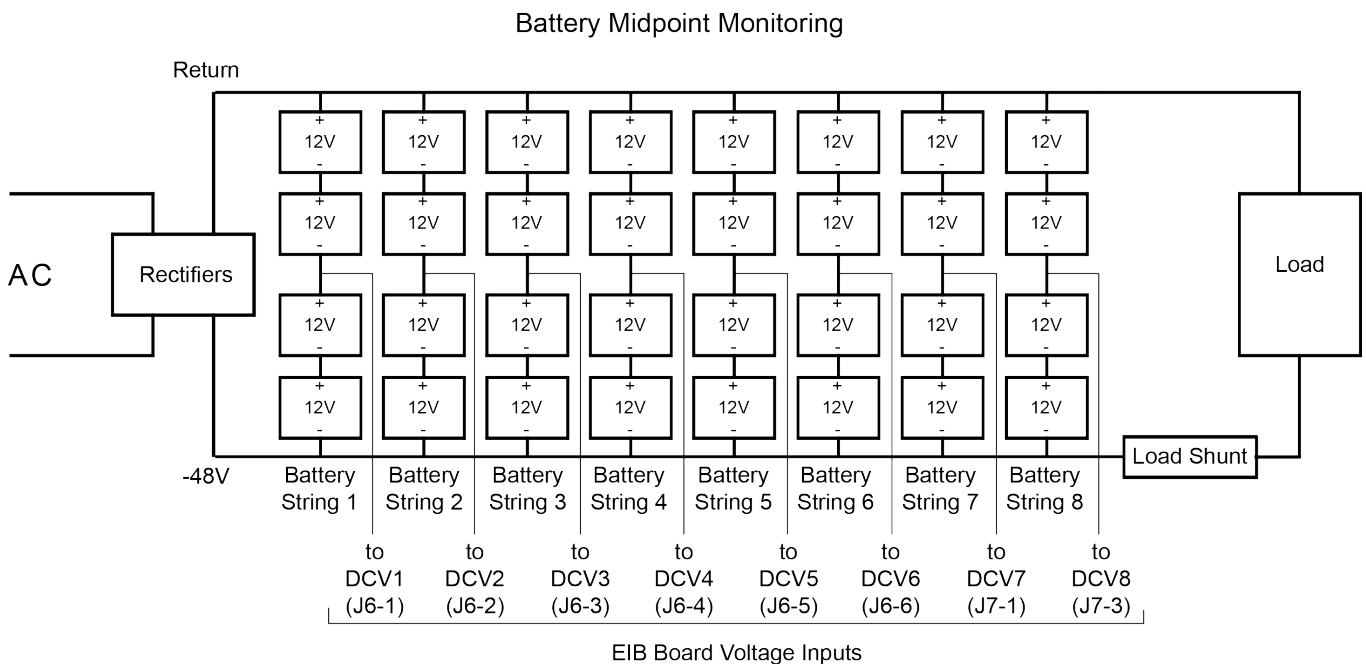
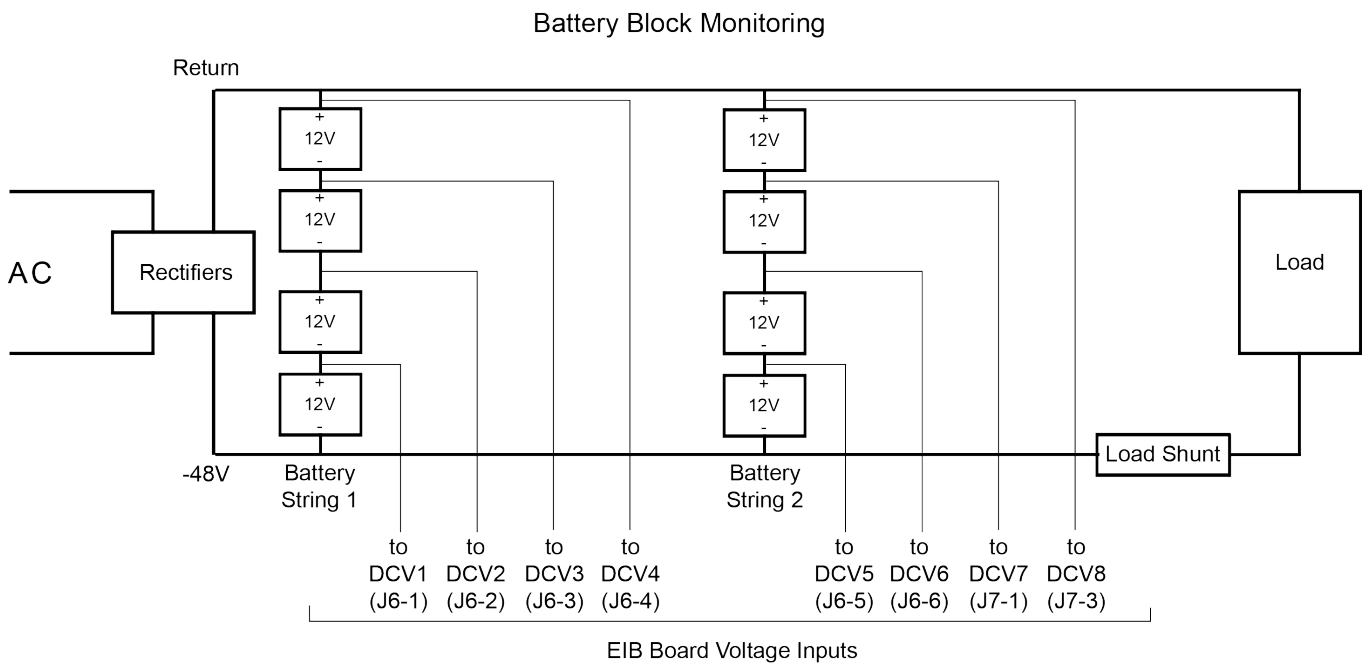
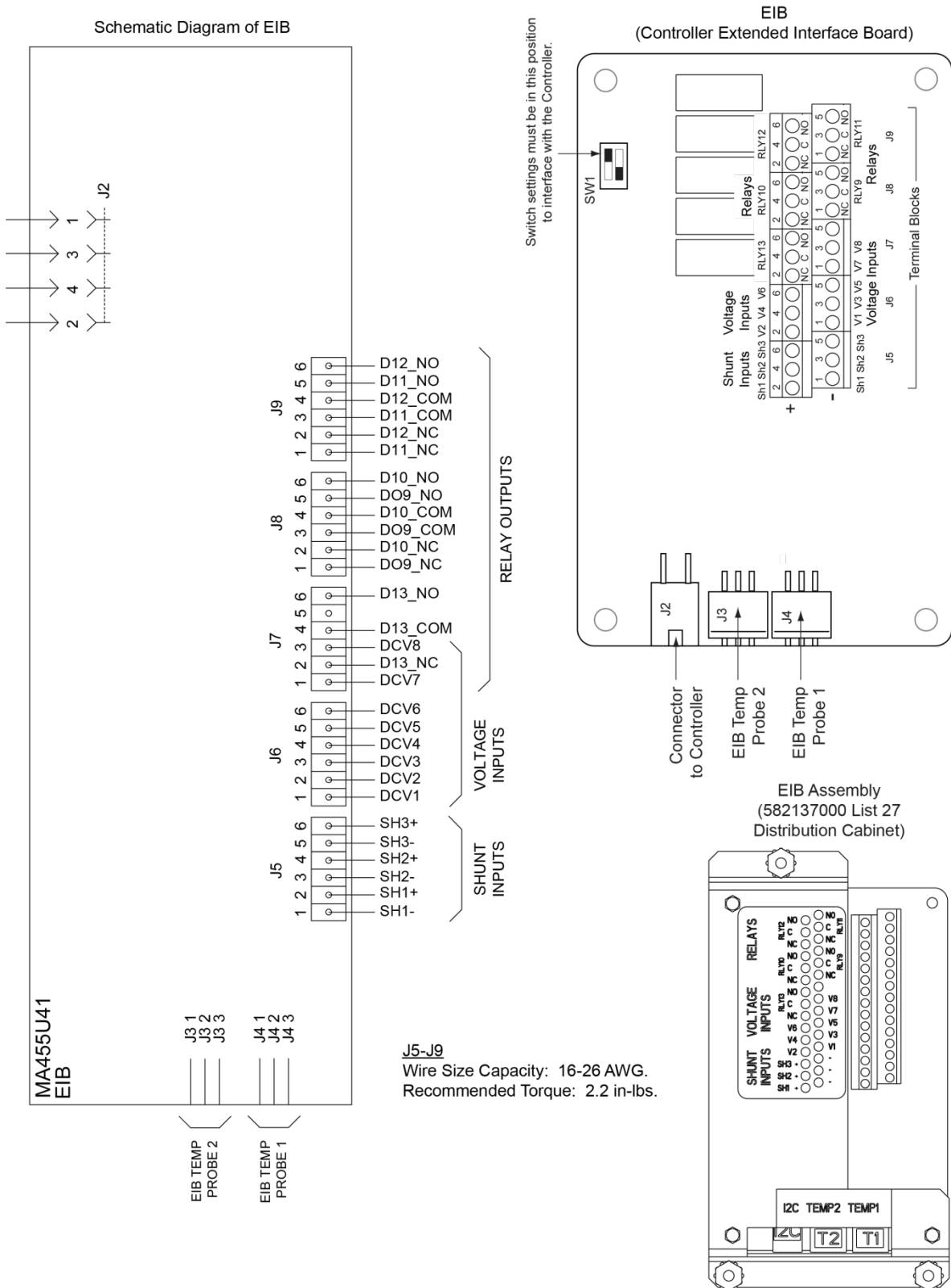


Figure 12: EIB (Extended Interface Board) Connections



**Table 3:** Shunt Inputs – EIB

Shunt Input	EIB Pin No.		Factory Wiring	Default Function	Customer Defined Function
Sh1	J5-2	+	--	none	
	J5-1	-	--		
Sh2	J5-4	+	--	none	
	J5-3	-	--		
Sh3	J5-6	+	--	none	
	J5-5	-	--		

**Table 4:** Voltage Inputs – EIB

Voltage Input	EIB Pin No.	Default Function
1	J6-1	Battery Block Monitoring
2	J6-2	
3	J6-3	
4	J6-4	
5	J6-5	
6	J6-6	
7	J7-1	
8	J7-3	

**Table 5:** Programmable Relay Outputs – EIB

Programmable Relay Output		EIB Pin No.	Alarms Assigned to this Relay (Default)	Alarms Assigned to this Relay (Custom)
9	NO	J8-5	The relays may be preprogrammed for specific functions. Refer to the configuration drawing (C-drawing) supplied with your system for your system's specific configuration.	
	COM	J8-3		
	NC	J8-1		
10	NO	J8-6		
	COM	J8-4		
	NC	J8-2		
11	NO	J9-5		
	COM	J9-3		
	NC	J9-1		
12	NO	J9-6		
	COM	J9-4		
	NC	J9-2		
13	NO	J7-6		
	COM	J7-4		
	NC	J7-2		



**NOTE!** The relays energize during an alarm condition, closing the contacts between the C and NO terminals, and opening the contacts between the C and NC terminals.

## Controller Ethernet Connection (if required)

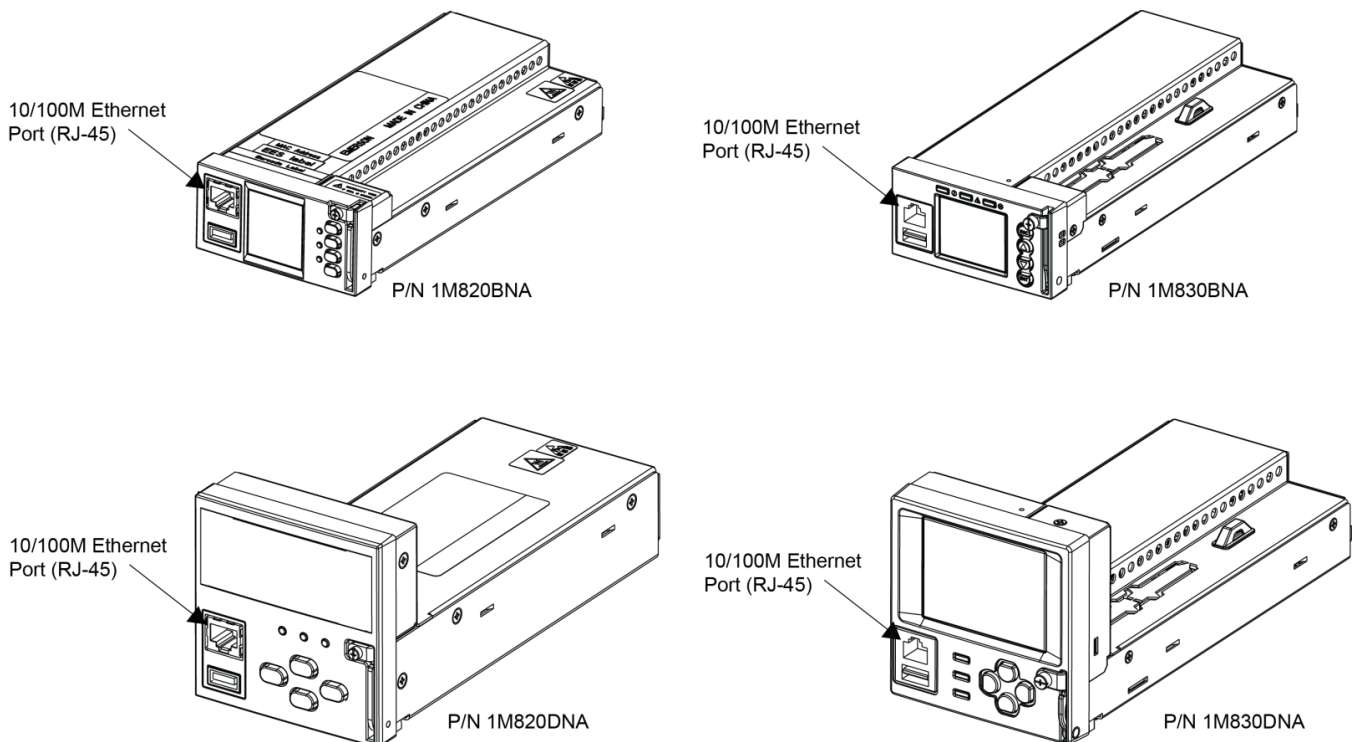
The controller provides a Web Interface via an Ethernet connection to a TCP/IP network. This interface can be accessed locally on a computer or remotely through a network. An RJ-45 10BaseT jack is provided on the front of the controller for connection into a customer's network. This jack has a standard Ethernet pin configuration scheme, twisted pair. Refer to **Figure 13** for location and **Table 6** for pin outs. Use shielded Ethernet cable (grounded at both ends). Note that the controller's RJ-45 jack is connected to chassis ground. Refer to the Controller Instructions (UM1M820BNA or UM1M830BNA) for operational details.

**NOTE!** You can access the Web pages of the power system locally by using a "crossover" or "straight" cable connected directly between your PC and the controller.

**WARNING!** The intra-building port(s) of the equipment or subassembly is suitable for connection to intra-building or unexposed wiring or cabling only. The intra-building port(s) of the equipment or subassembly **MUST NOT** be metallicly connected to the interfaces that connect to the OSP or its wiring. These interfaces are designed for use as intra-building interfaces only (Type 2 or Type 4 ports as described in GR-1089-CORE, Issue 4) and require isolation from the exposed OSP cabling. The addition of Primary Protectors is not sufficient protection in order to connect these interfaces metallicly to OSP wiring.

The intra-building port (RJ-45) of the equipment or subassembly must use shielded intra-building cabling/wiring that is grounded at both ends.

**Figure 13:** Controller Ethernet Port





**Table 6:** Controller RJ-45 Ethernet Port Pin Configuration

Port Pin Number	Name	Definition
1	Tx+	Write Signal +
2	Tx-	Write Signal -
3	Rx+	Read Signal +
4	--	no connection
5	--	no connection
6	Rx-	Read Signal -
7	--	no connection
8	--	no connection

### Connecting a Device or System to the Controller's CAN Bus (List 27 Distribution Cabinet Only)

A supporting device or system may be connected to the Controller's CAN Port located inside a List 27 Distribution Cabinet. Refer to **Figure 7** for location. Refer to **Table 7** for pin-outs. Refer also to the external device's or system's instruction manual.

#### General Procedure

1. Remove the CAN termination plug from the CAN Port connector (see **Figure 7** for location). Connect the device or system to the Controller's CAN port. Refer to **Table 7** for pin-outs. Ensure that the last device on the controller's CAN bus has a CAN termination plug. Refer also to the external device's or system's instruction manual.

#### Optional SM-Temp Module

The analog output of the SM-Temp Module may be connected to a controller temperature port input. In lieu of connecting the analog output of the SM-TEMP module to a controller temperature port input, the SM-TEMP module can simply be connected at the end of the Controller's CAN bus (for system's equipped with an ACU+, requires ACU+ version 3.02 or later). Refer to the SM-Temp Module Instructions (UM547490) for details.

#### CAN Bus Procedure

1. Remove the CAN termination plug from the CAN Port connector (see **Figure 7** for location). Connect the SM-Temp Module CAN bus to the CAN Port connector. Refer to **Table 7** for pin-outs. Ensure the last SM-Temp Module (or if only one) has a CAN termination strap as shown in the SM-Temp Module Instructions (UM547490).

**Table 7:** CAN Port Connections

Controller CAN Port (RJ-45)		SM-Temp Module CAN Port
Pin Number	Function	Pin Number
1	CAN L	TB1-5 (CAN L)
2	CAN H	TB1-3 (CAN H)
3	--	--
4	--	--
5	--	--
6	--	--
7	--	--
8	--	--

### Load Connections to a List 27 Distribution Cabinet

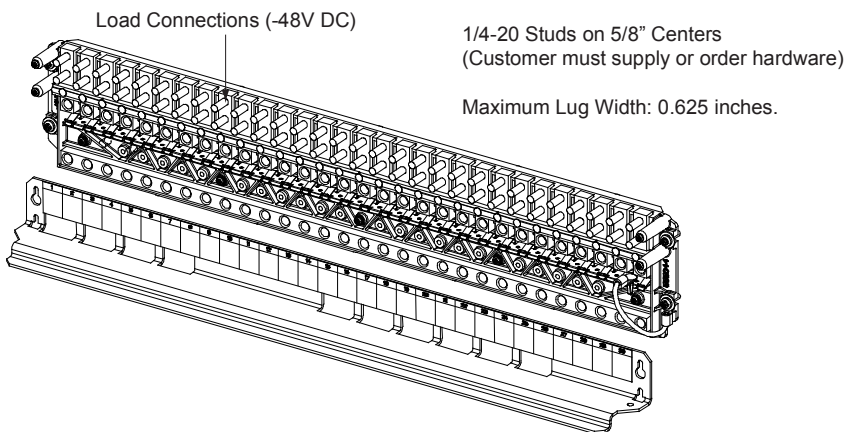
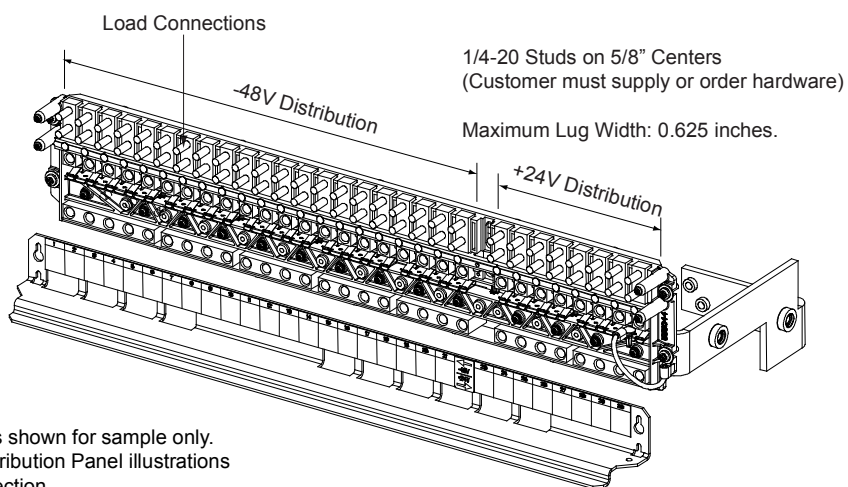
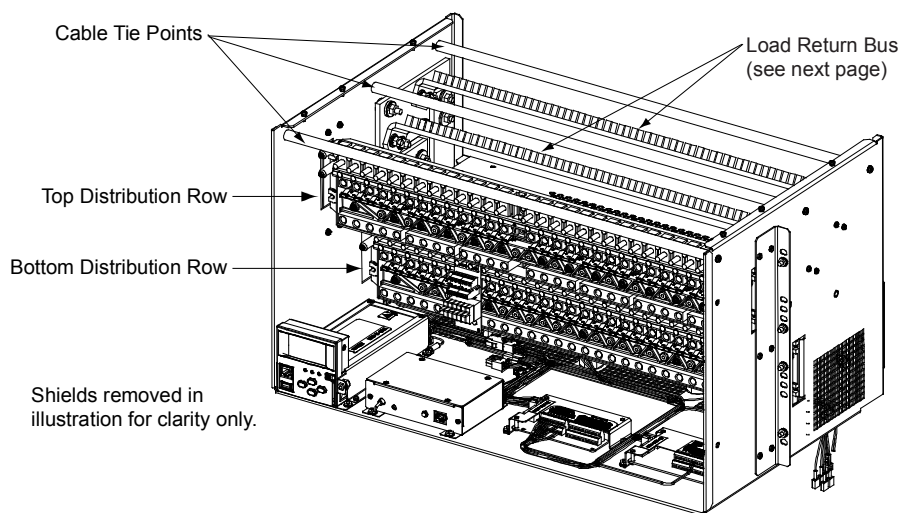
Load leads are connected to the individual load busbars located on the distribution panels (refer to **Figure 14**). Load return leads are connected to separate return busbars located at the top of the distribution cabinet (refer to **Figure 15**). Refer to **Figure 17** through **Figure 22** for illustrations of the available distribution panels.

Refer to **Figure 16** if an optional “Bullet Nose Type 6-Position GMT Distribution Fuse Block” is furnished.

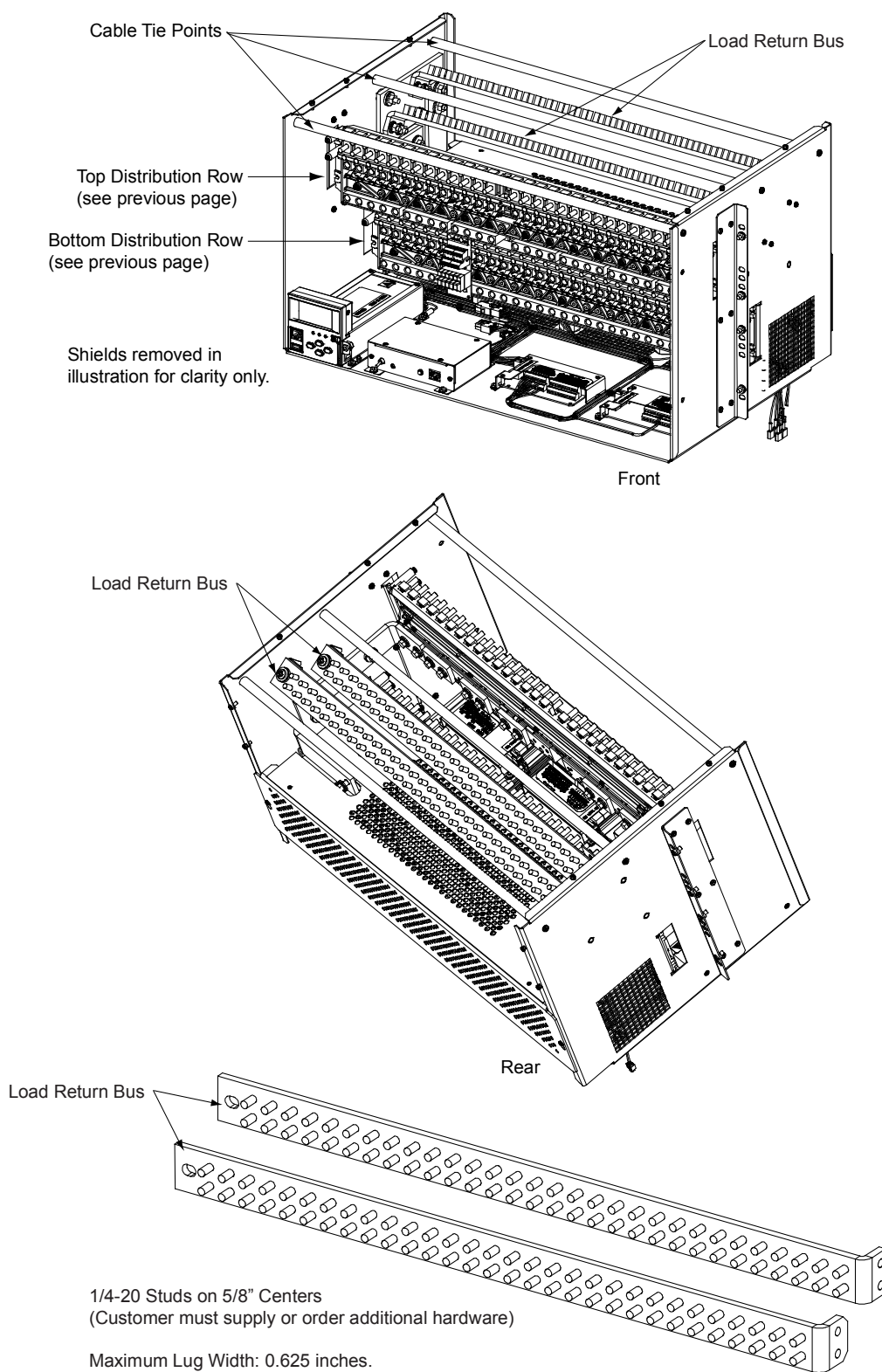
#### **Recommended Torque**

- 72 in-lbs for 1/4-inch hardware (when using standard flat and lock washer).

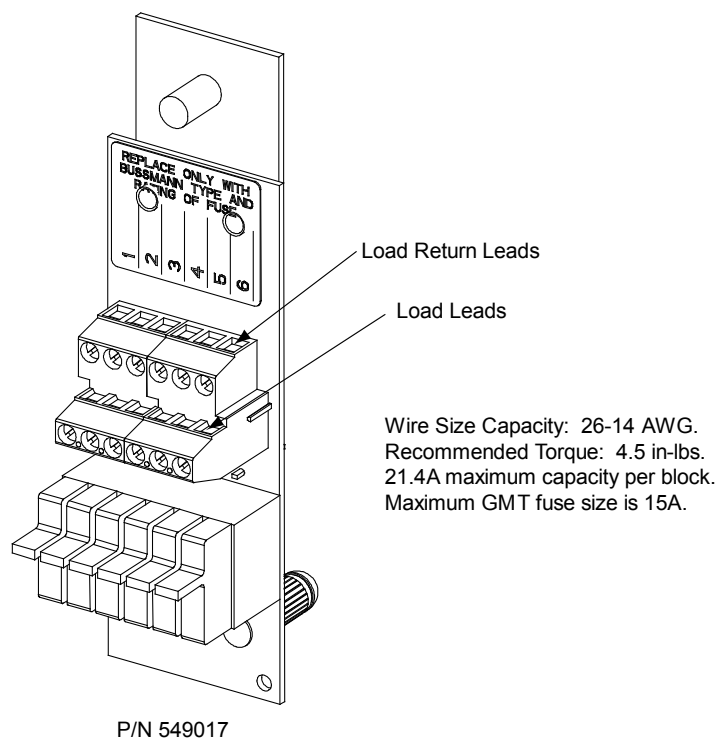
**Figure 14:** Load Side Connections in a List 27 Distribution Cabinet



**Figure 15:** Load Return Side Connections in a List 27 Distribution Cabinet

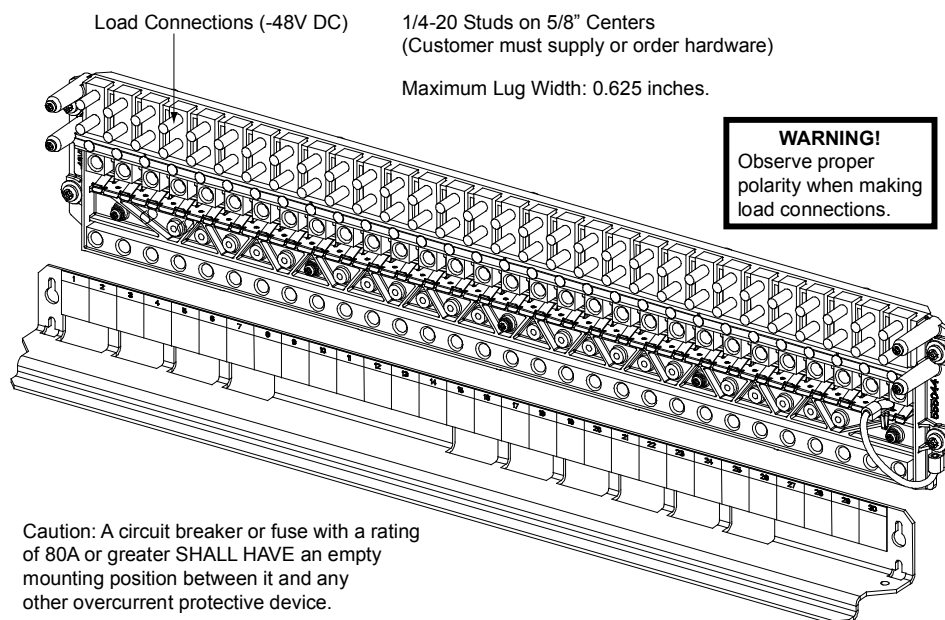


**Figure 16:** Load Connections to GMT Fuse Block (P/N 549017) in a List 27 Distribution Cabinet



**Load Connections to Single Voltage Distribution Panels in a List 27 Distribution Cabinet**

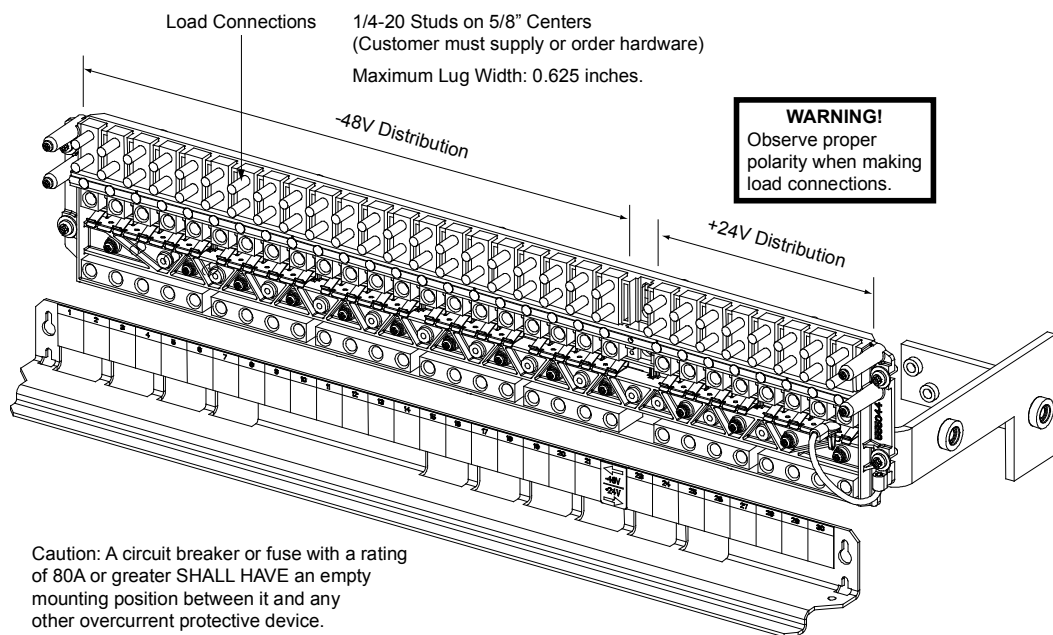
**Figure 17:** List AC Load Connections  
(30) -48 VDC Bullet/TPS/TLS Circuit Breaker/Fuse Positions



## Load Connections to Dual Voltage Distribution Panels in a List 27 Distribution Cabinet

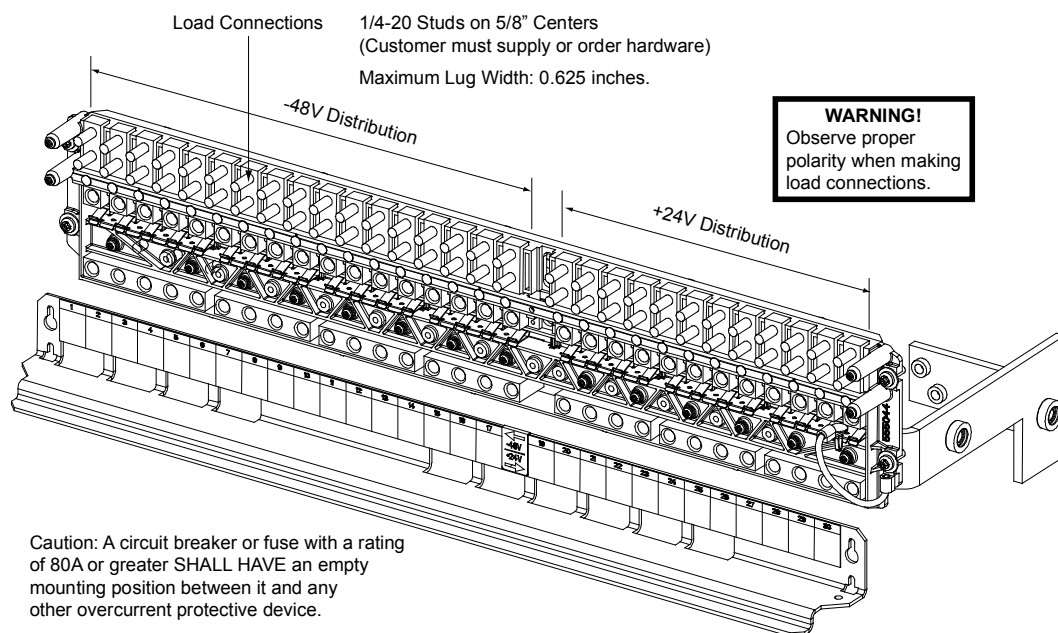
**Figure 18:** List DH Load Connections

(21) -48 VDC Bullet/TPS/TLS Circuit Breaker/Fuse Positions and  
(8) +24 VDC Bullet/TPS/TLS Circuit Breaker/Fuse Positions



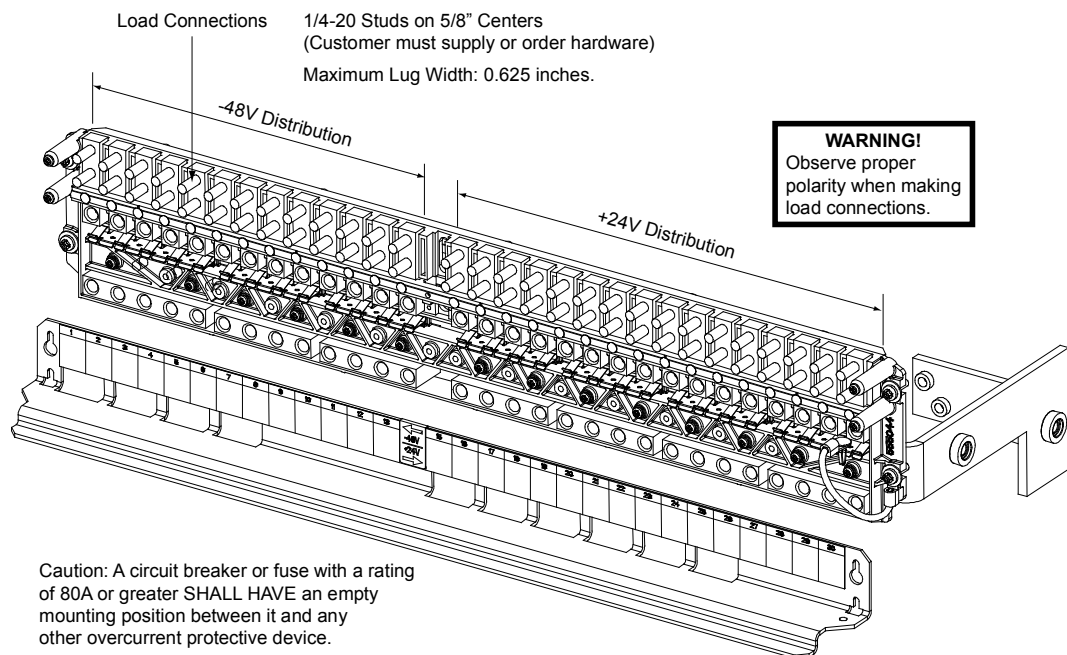
**Figure 19:** List DI Load Connections

(17) -48 VDC Bullet/TPS/TLS Circuit Breaker/Fuse Positions and  
(12) +24 VDC Bullet/TPS/TLS Circuit Breaker/Fuse Positions



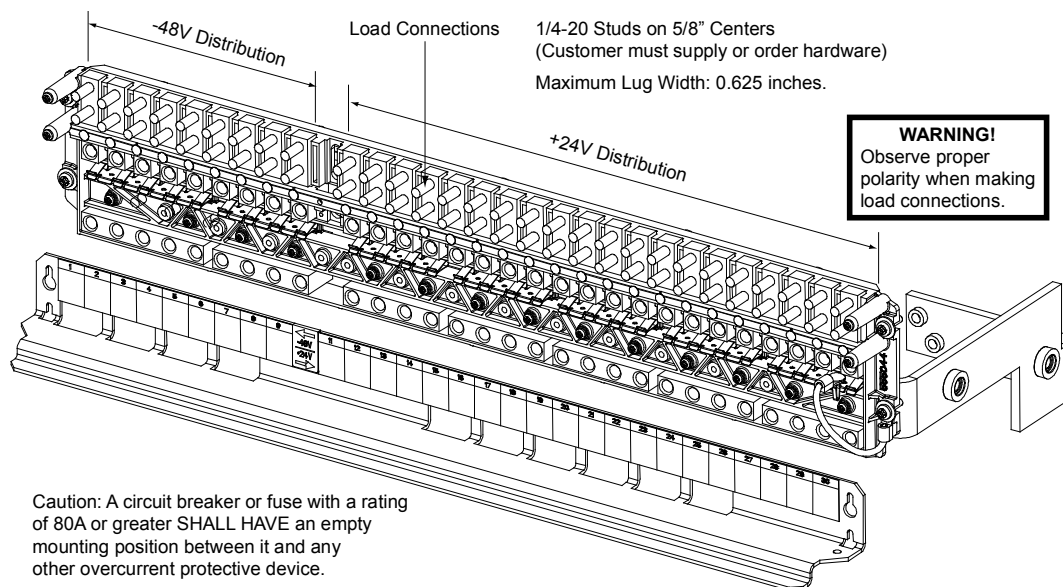
**Figure 20:** List DJ Load Connections

(13) -48 VDC Bullet/TPS/TLS Circuit Breaker/Fuse Positions and  
 (16) +24 VDC Bullet/TPS/TLS Circuit Breaker/Fuse Positions



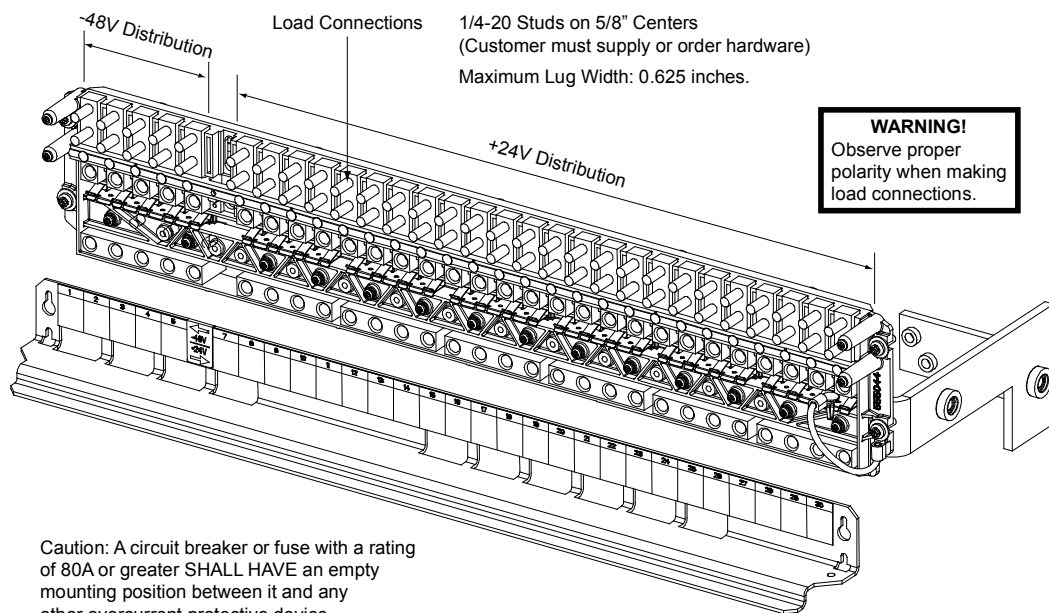
**Figure 21:** List DK Load Connections

(9) -48 VDC Bullet/TPS/TLS Circuit Breaker/Fuse Positions and  
 (20) +24 VDC Bullet/TPS/TLS Circuit Breaker/Fuse Positions



**Figure 22:** List DL Load Connections

(5) -48 VDC Bullet/TPS/TLS Circuit Breaker/Fuse Positions and  
 (24) +24 VDC Bullet/TPS/TLS Circuit Breaker/Fuse Positions





## Load Connections to a List 7 Distribution Cabinet

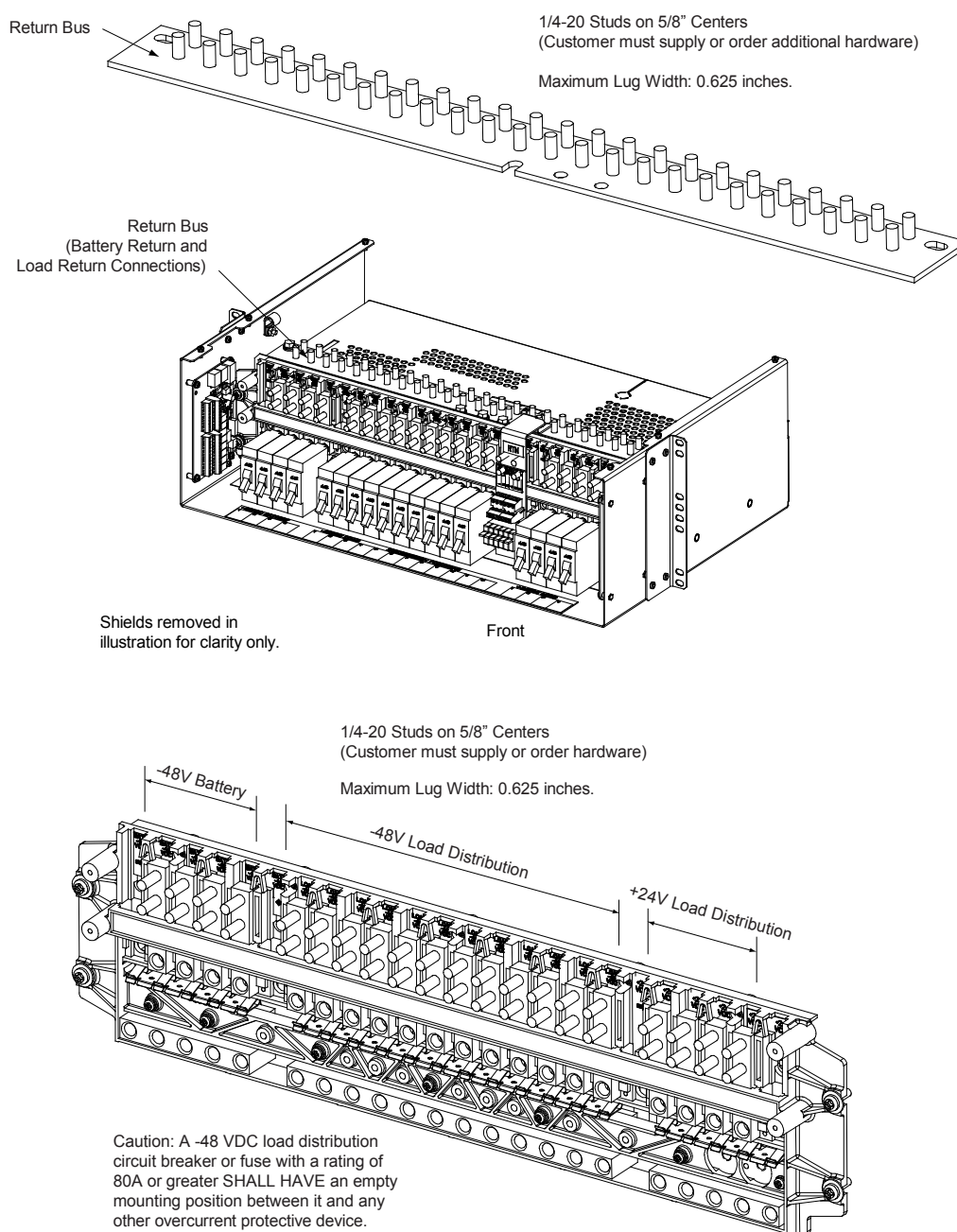
Load leads are connected to the individual load busbars located on the distribution panel (refer to **Figure 23**). Load return leads are connected to the return busbar located at the top of the distribution cabinet (refer to **Figure 23**).

Refer to **Figure 24** if an optional “Bullet Nose Type 6-Position GMT Distribution Fuse Block” is furnished.

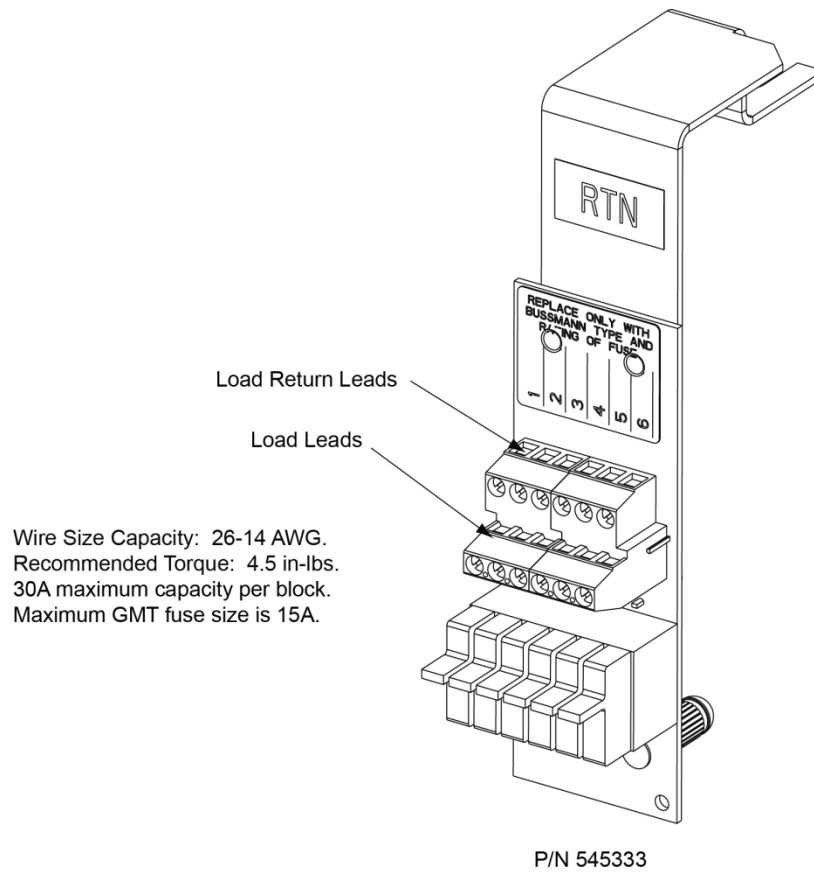
### Recommended Torque

- 72 in-lbs for 1/4-inch hardware (when using standard flat and lock washer).

**Figure 23:** Load and Load Return Connections in a List 7 Distribution Cabinet



**Figure 24:** Load Connections to GMT Fuse Block (P/N 545333) in a List 7 Distribution Cabinet



## Battery Connections to a List 27 Distribution Cabinet

Input battery leads are connected to the battery busbar and battery return busbar. Customer must supply lug mounting hardware. Refer to **Figure 25**.

### Important Safety Instructions



**DANGER!** Adhere to the “Important Safety Instructions” presented at the front of this document.

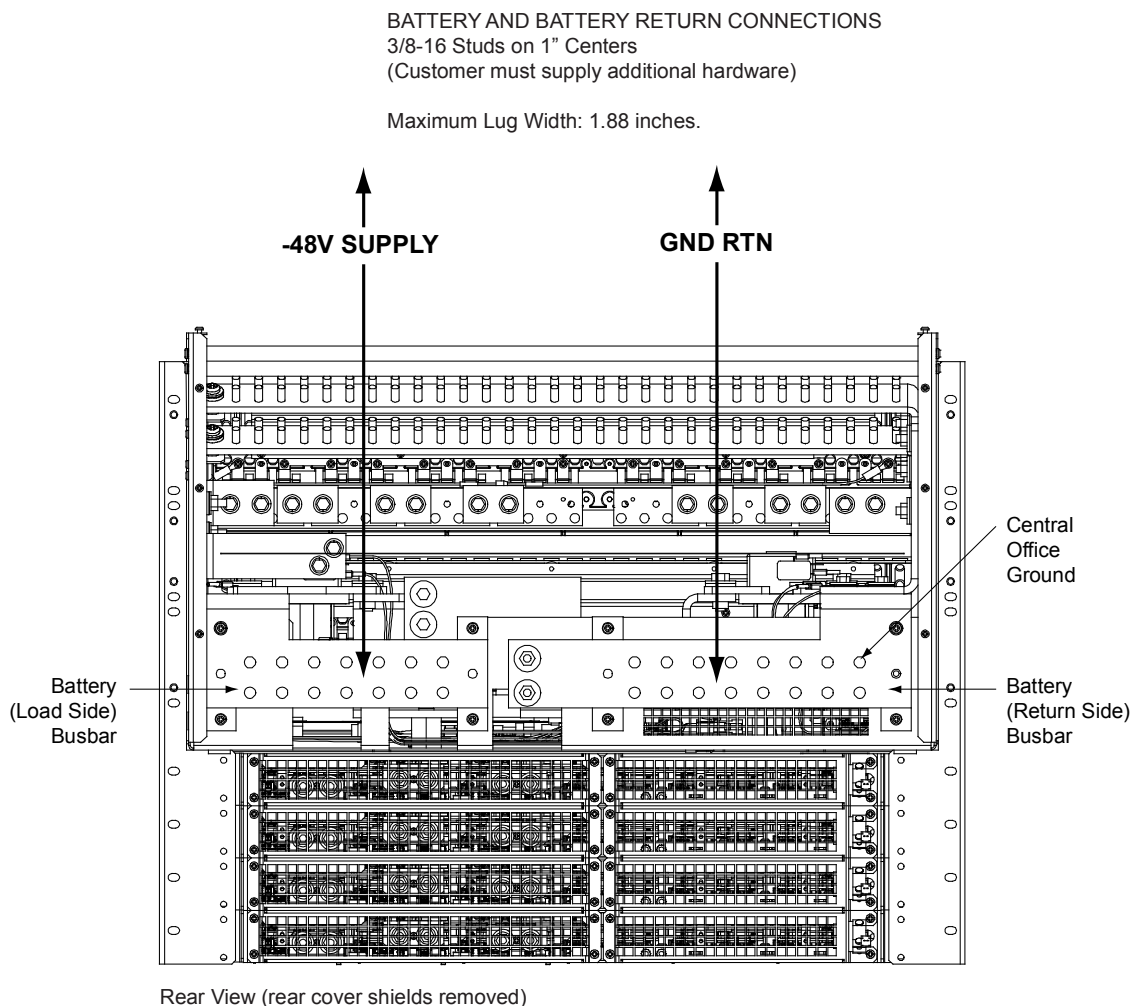


**WARNING!** Observe proper polarity when making battery connections.

### Recommended Torques

- 300 in-lbs for 3/8-inch hardware (when using standard flat and lock washer).
- 180 in-lbs for 3/8-inch hardware (when using a Belleville lock washer).

**Figure 25:** Battery and Central Office Ground Connections in a List 7 Distribution Cabinet



## Battery Connections to a List 7 Distribution Cabinet

Input battery leads are connected to the individual battery busbars located on the distribution panel. Battery return leads are connected to the return busbar located at the top of the distribution cabinet. Customer must provide (or order) lug mounting hardware. Refer to **Figure 26**.

### Important Safety Instructions



**DANGER!** Adhere to the “Important Safety Instructions” presented at the front of this document.

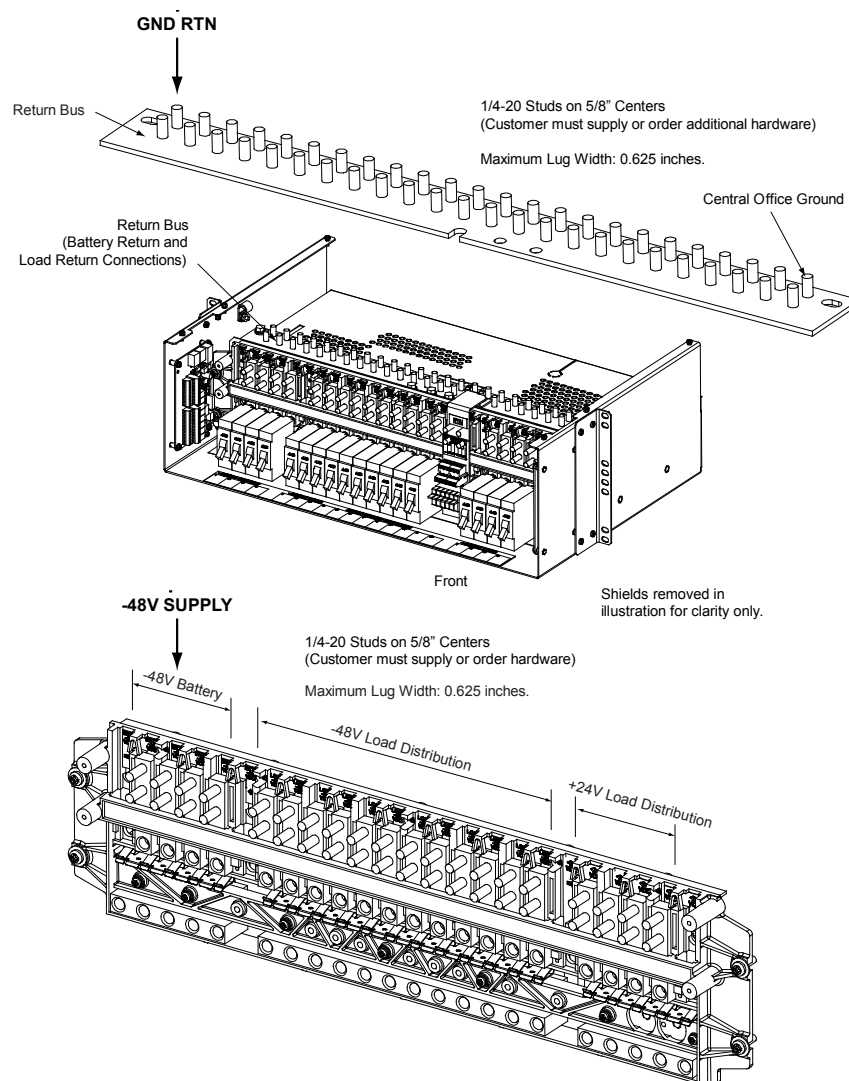


**WARNING!** Observe proper polarity when making battery connections.

### Recommended Torques

- 72 in-lbs for 1/4-inch hardware (when using standard flat and lock washer).

**Figure 26:** Battery and Central Office Ground Connections in a List 7 Distribution Cabinet



# INSTALLING RECTIFIER AND CONVERTER MODULES

## General

Rectifier and converter modules can be inserted or removed with power applied (hot swappable).

### System with List 7 Distribution Cabinet

In the top module mounting shelf, rectifier modules can be installed in any mounting position except the far left. Converter modules CANNOT be installed in the top shelf. See **Figure 27**.

In the bottom module mounting shelf, rectifier modules can be installed in any mounting position. Converter modules can be installed in any of the three far right mounting positions (as viewed from the front). See **Figure 27**.

### System with List 27 Distribution Cabinet

Rectifier modules can be installed in any mounting position of each module mounting shelf. Converter modules can be installed in any of the three far right mounting positions of each module mounting shelf (as viewed from the front). See **Figure 28**.

## Installing Rectifier and Converter Modules



**NOTE!** Each rectifier and converter module locks into the module mounting shelf by means of a latch located on the bottom of the module. The latch and module handle are interactive. Pushing the handle up into the module's front panel causes the latch to extend to the locking position; pulling the handle down out from the module's front panel causes the latch to retract. See **Figure 27** or **Figure 28**.

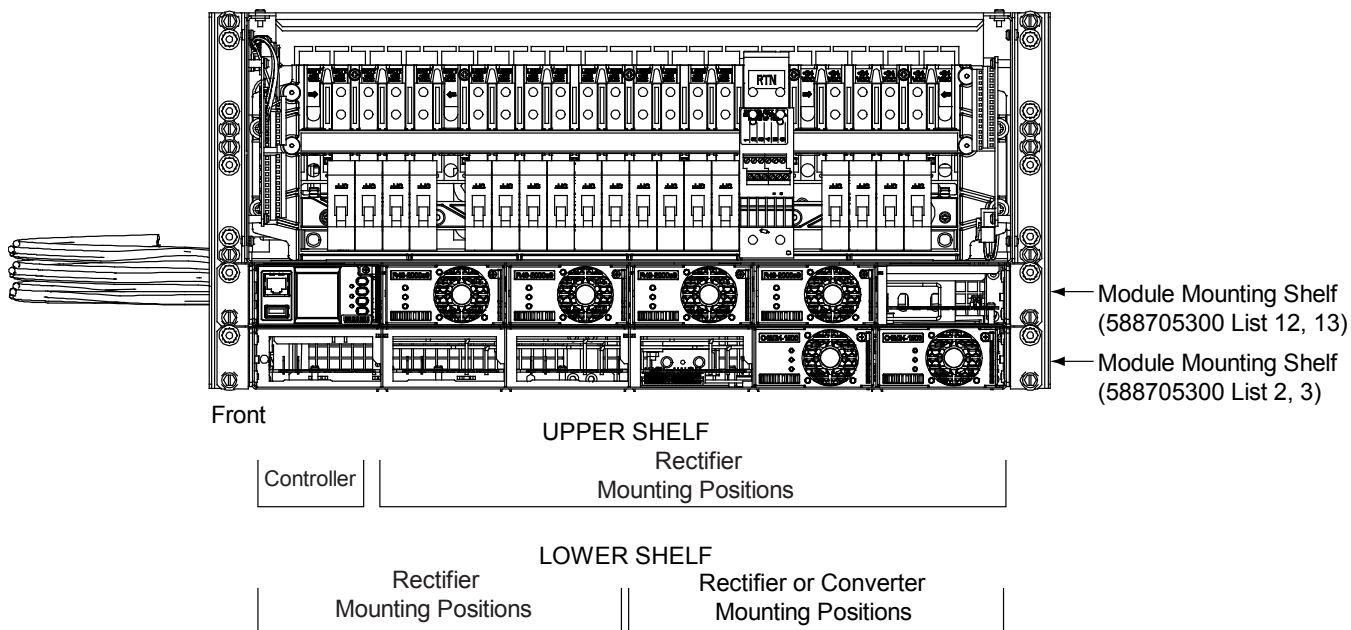


**WARNING!** To prevent damage to the latching mechanism, ensure the handle is in the open position when installing or removing a module. NEVER hold the handle in the closed position when installing a module into a shelf.

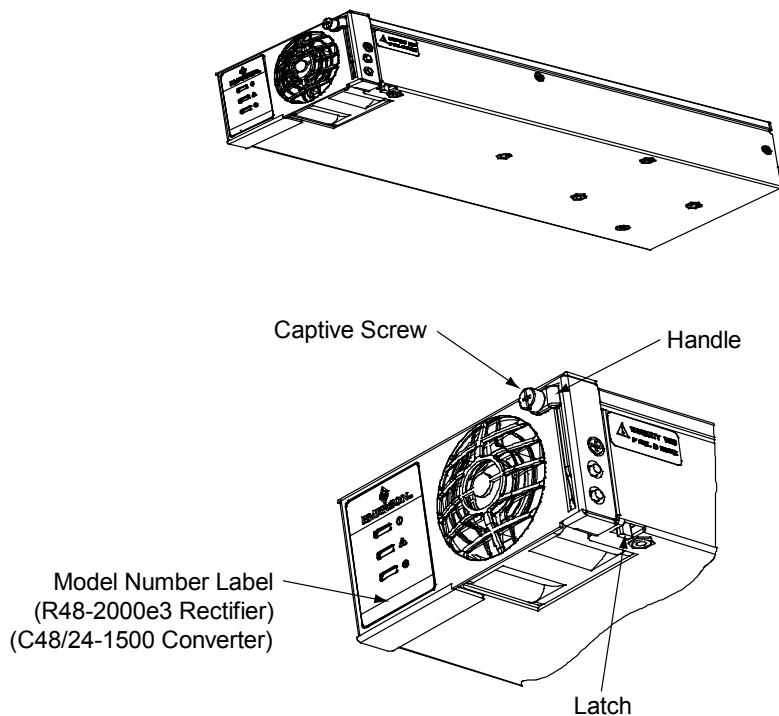
### Procedure

1. Unpack the modules.
2. Note the model number located on the front of each module. Model numbers starting with the letter "R" are rectifier modules. Model numbers starting with the letter "C" are converter modules.
3. Place the module into an unoccupied mounting position without sliding it in completely. See **Figure 27** or **Figure 28** for acceptable positions.
4. Loosen the captive screw on the module's handle. Pull the handle down out from the module's front panel (this will also retract the latch mechanism). See **Figure 27** or **Figure 28**.
5. Push the module completely into the shelf.
6. Push the handle up into the module's front panel. This will lock the module securely to the shelf. Tighten the captive screw on the handle.
7. Repeat the above steps for each module being installed in the system.
8. After the modules are physically installed in the mounting shelf(s), they are ready for operation immediately after power is supplied to them.

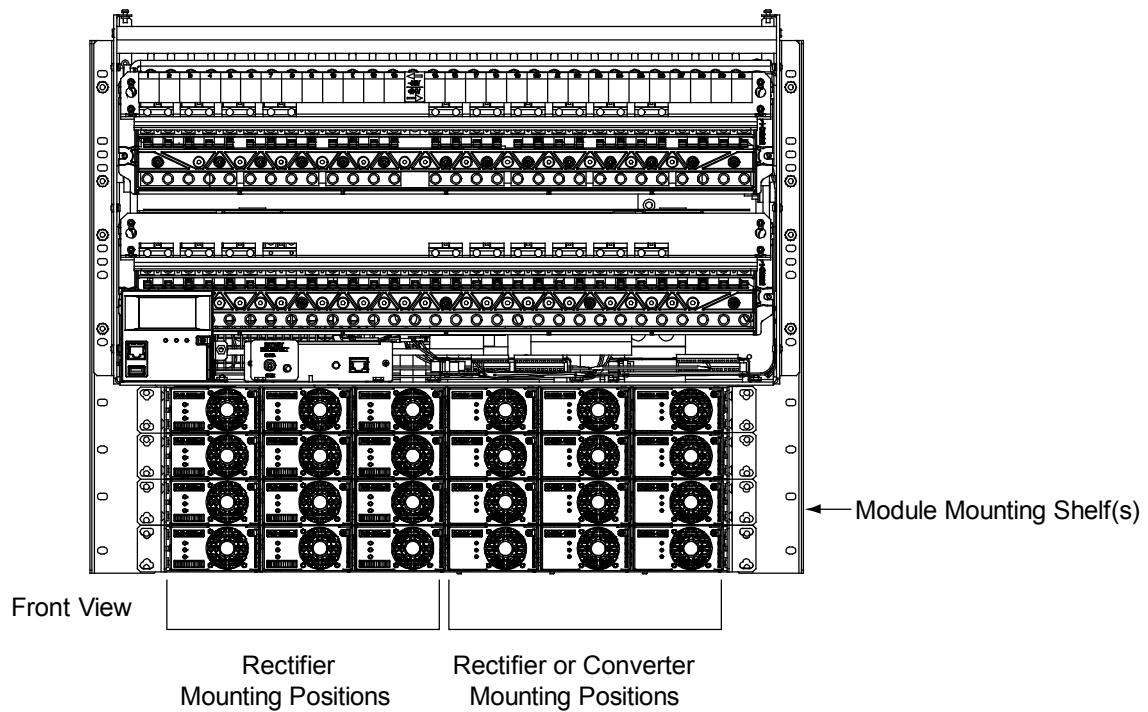
**Figure 27:** Installing Rectifier and Converter Modules, System with List 7 Distribution Cabinet



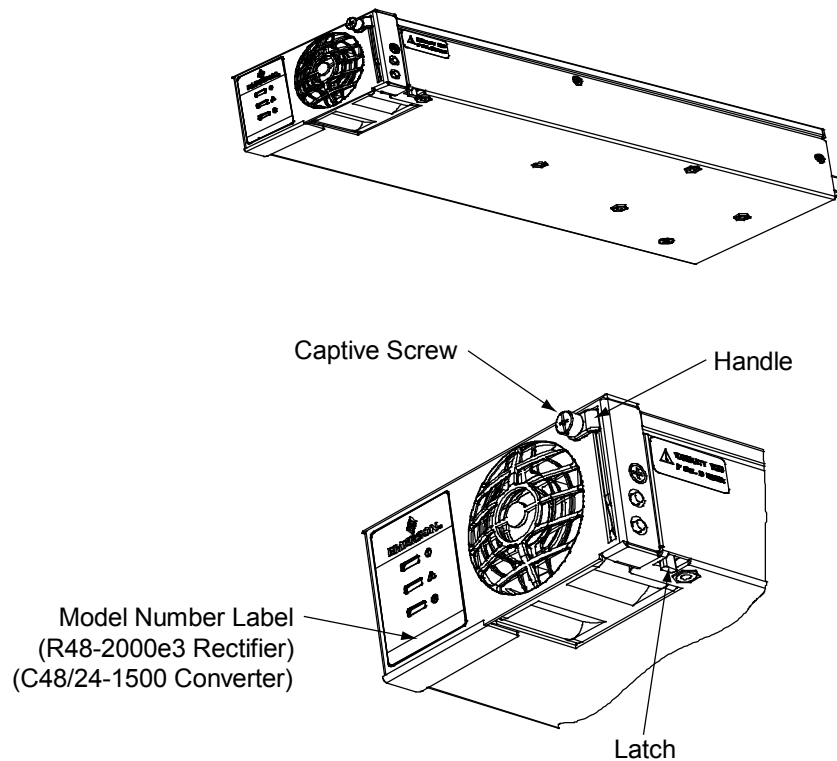
Rectifier or Converter Module



**Figure 28:** Installing Rectifier and Converter Modules, System with List 27 Distribution Cabinet



Rectifier or Converter Module



# INITIALLY STARTING, CONFIGURING, AND CHECKING SYSTEM OPERATION

## Important Safety Instructions



**CAUTION!** Performing various steps in the following procedures may cause a service interruption and/or result in the extension of alarms. Notify any appropriate personnel before starting these procedures. Also, notify personnel when these procedures are completed.

## Initial Startup Preparation

- Ensure that module mounting positions are filled by a rectifier module or converter module as desired. It is acceptable for positions to be left vacant.
- Refer to the configuration drawing (C-drawing) supplied with your power system documentation for factory settings of adjustable parameters.

## Initially Starting the System

### Procedure

1. Apply DC input power to the system by closing the external DC disconnect(s) or protective device(s) that supplies battery power to the system, if furnished.
2. Apply AC input power to the system by closing ALL external AC disconnects or protective devices that supply AC power to the module mounting shelves. Rectifiers and converters (if furnished) automatically start.
3. Place each distribution circuit breaker (if furnished) to the ON position.

## NCU Controller Procedure

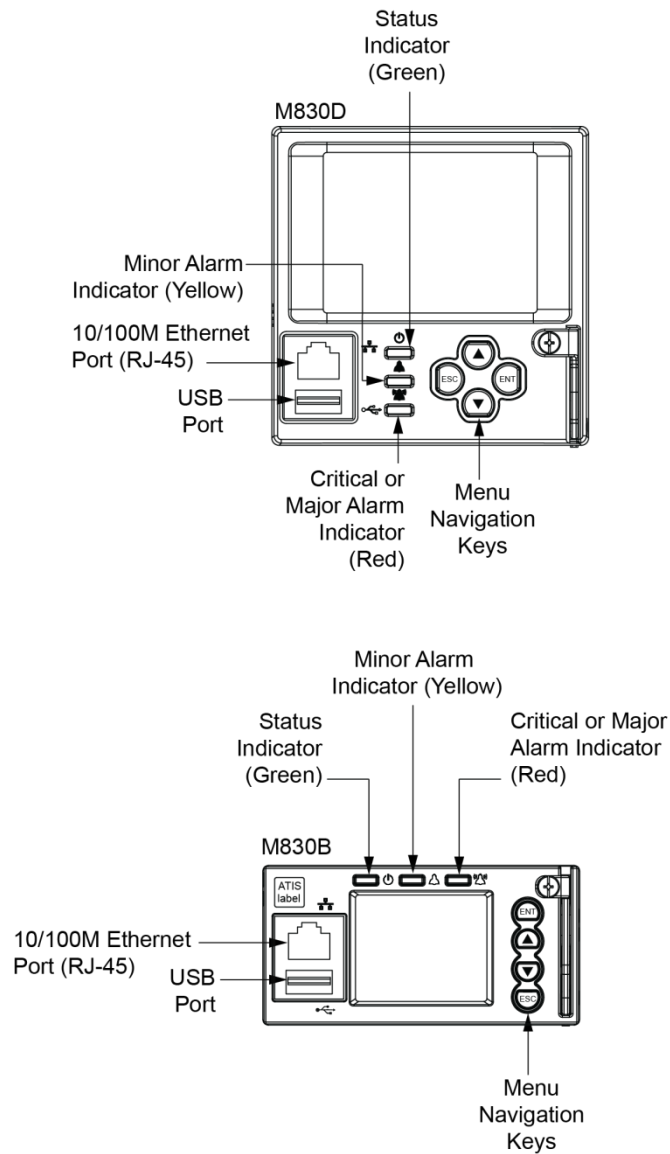
Refer to the NCU Instructions (UM1M830BNA) for detailed instructions.

### NCU Controller Initialization

Refer to **Figure 29** for locations of the NCU local indicators and navigation keys.



**Figure 29:** NCU Local Indicators and Navigation Keys

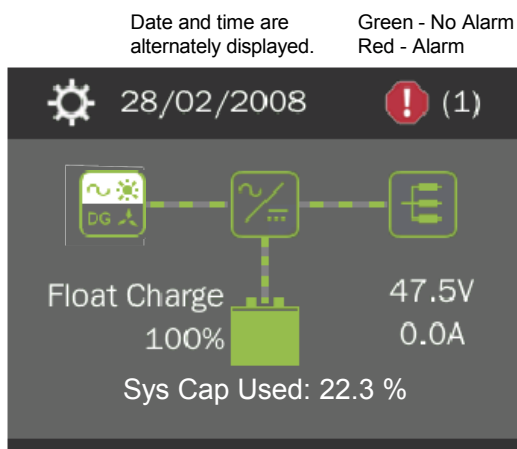


## Procedure

**NOTE!** The initialization routine takes several minutes. During that time various alarm indicators may illuminate on the NCU front panel and an audible alarm may sound. Disregard all alarms. An audible alarm can be silenced at any time by momentarily depressing the **ENT** key on the NCU Controller.

1. After the NCU is powered on, the display shows the “Logo” screen. The controller is initializing.
2. When initialization is complete, the language screen appears. Press the up or down arrow key to select the desired language. Press the **ENT** key to confirm the selection.
3. The Main Menu displays.

## Main Menu



Date and time are alternately displayed.

Green - No Alarm  
Red - Alarm

The number in ( ) indicates the total number of alarms.

Graphics	Menu Name	Description
	Alarm (Green - No Alarm) (Red - Alarm)	View active alarms and alarm history.
	Settings	Gain access to the NCU Controller's settings menus.
	Input Power	View AC, Solar, DG, and Wind related information.
	Module	View rectifier, solar converter, and converter module related information.
	DC	View DC equipments related information.
	Battery	View battery related information.

Press the UP and DOWN keys to highlight the desired Menu graphic in the Main Menu.

Press the ENT key to enter the selected menu.

To reboot the Controller, from the Main Menu press the ENT and ESC keys at the same time. Release both keys. Press ENT to confirm.

4. System information is displayed in multiple screens. Press the ESC key to view other system information. Press the down arrow key to view the next screen. Press the ESC key to return to the Main Menu.
5. From the Main Menu, press the UP and DOWN keys to highlight the desired Menu graphic in the Main Menu. Press the ENT key to enter the selected menu.

**NOTE!** Repeatedly press the “ESC” key to return in reverse order level by level from any submenu until the Main Menu appears.

6. Verify and set the NCU controller as required for your application. Refer to the NCU Instructions (UM1M830BNA) for procedures. Note that you will have to program the NCU for any temperature probes and external inputs/outputs connected to the IB2 Interface Board and EIB Extended Interface Board. Refer also to “NCU Start Wizard” on page 51.



**NOTE!** When setting total rectifier current limit, the set point to each unit is the total set point divided by the number of units. For example, if the system contains five rectifiers and the current limit is set to 150 amps then each rectifier has a current limit set point of 30 amps. If one or more rectifiers are removed or fail it will take several seconds for the individual set points to the remaining rectifiers to be reset. In the example given, if one rectifier is removed the current limit set point will drop to 120 amps (30 amps times four remaining rectifiers) until the controller can send updated set points to the remaining rectifiers. This takes a couple communication cycles (several seconds) after which each rectifier would have a new set point of 37.5 amps for a total of 150 amps. The total current limit of the rectifiers should not be set such that the loss of the redundant rectifiers will cause this temporary set point to drop below the actual maximum expected load. If batteries are used on the rectifier output, the batteries should support the load until the current limit set points can be re-established due to loss of a rectifier.

### **NCU Start Wizard**

For initial startup, you can perform the Start Wizard from the local keypad and display to enter basic programmable parameters in one session. Refer to the “Start Wizard” section in the NCU Instructions (UM1M830BNA).

### **Verifying the Configuration File**

Your NCU was programmed with a configuration file that sets all adjustable parameters. The version number of the configuration file can be found on the configuration drawing (C-drawing) that is supplied with your power system documentation, and on a label located on the NCU. You can verify that the correct configuration file has been loaded into your NCU by performing the following procedure.

#### **Procedure**

1. With the Main Menu displayed, press **ESC**. A screen displays the NCU name, serial number, IP number, software version, and hardware version.
2. Press the **DOWN** key. A screen displays the configuration version number, NCU file system, and MAC address.
3. Press **ESC** to return to the Main Menu.

### **Checking Basic System Settings**

Navigate through the controller menus and submenus to check system settings. You can adjust any parameter as required. Note that these settings can also be checked (and changed if required) via the WEB Interface. Refer also to “NCU Start Wizard” on page 51.



**NOTE!** Repeatedly press the “ESC” key to return in reverse order level by level from any submenu until the Main Menu appears.

#### **Procedure**

1. **To Select a Sub-Menu:**  
Press the UP and DOWN keys to highlight the desired sub-menu. Press the ENT key to enter the selected sub-menu.
2. **To Select a User:**  
To select a User, use the UP and DOWN keys to move the cursor to the Select User field. Press ENT. Use the UP and DOWN keys to select a User previously programmed into the NCU. Press ENT to select the User. Note that only Users programmed into the NCU are shown. Users are programmed via the Web Interface. The default User is admin.

3. **To Enter a Password:**

If a password screen opens, a password must be entered to allow the User to make adjustments. To enter a password, use the UP and DOWN keys to move the cursor to the Enter Password field. Press ENT. Use the UP and DOWN keys to choose a character. Press ENT to accept and move to the next character. Continue this process until all characters are entered. Press ENT again to accept the password. The default password is 640275.

4. **To Change a Parameter:**

Press the UP and DOWN keys to move up and down the list of parameters. Press ENT to select the parameter. Press the UP and DOWN keys to change the parameter. Press ENT to make the change. Press ESC to cancel the change.

5. **Table 8** shows the menu navigation for some basic settings. Refer to the separate NCU Manual (UM1M830BNA) supplied with your power system for complete Local Display menus.

**Table 8:** NCU Basic Settings Menu Navigation

Parameter	Menu Navigation
Date	Main Menu / Settings Icon / Sys Settings / Date.
Time	Main Menu / Settings Icon / Sys Settings / Time.
IP Communications Parameters (IP address, subnet mask address, gateway address)	Main Menu / Settings Icon / Comm Settings / enter parameters.
Float Voltage	Main Menu / Settings Icon / Batt Settings / Charge / Float Voltage.
Equalize Voltage	Main Menu / Settings Icon / Batt Settings / Charge / EQ Voltage.
Battery Current Limit	Main Menu / Settings Icon / Batt Settings / Charge / Curr Limit Mode and Batt Curr Limit.
Battery Capacity	Main Menu / Settings Icon / Batt Settings / Batt1 Settings or Batt2 Settings / Rated Capacity.
Reset Battery Capacity	Main Menu / Settings Icon / Batt Settings / Basic Settings / Reset Batt Cap
BTRM Feature	<b>Web Menu Navigation Only:</b> Settings Menu / Battery Tab.
Battery Charge Temperature Compensation	Main Menu / Settings Icon / Batt Settings / Temp Comp (enter parameters).
HVSD Limit	<b>Web Menu Navigation Only:</b> Settings Menu / Rectifiers Tab / HVSD (set to enabled) then set HVSD Limit.
Rectifier Current Limit	Main Menu / Settings Icon / Rect Settings / Current Limit (set to enabled) then set Curr Limit Pt.
Over Voltage Alarm 1	Main Menu / Settings Icon / Other Settings / Over Voltage 1.
Over Voltage Alarm 2	Main Menu / Settings Icon / Other Settings / Over Voltage 2.
Under Voltage Alarm 1	Main Menu / Settings Icon / Other Settings / Under Voltage 1.
Under Voltage Alarm 2	Main Menu / Settings Icon / Other Settings / Under Voltage 2.

### **Changing Battery Capacity Rating in the NCU**

Change the battery capacity setting of the NCU to match the battery connected to the power system.

#### **Local Menu Navigation:**

Main Menu / Settings Icon / Batt Settings / Batt1 Settings or Batt2 Settings / Rated Capacity.

#### **Web Menu Navigation:**

Settings Menu / Battery Tab / Batt1 Rated Capacity and Batt2 Rated Capacity.

Refer to the NCU Instructions (UM1M830BNA) for detailed instructions.

### **Configuring the NCU Identification of Rectifiers and Assigning which Input Feed is Connected to the Rectifiers**

When rectifiers are all installed prior to applying power and starting the system, the order in which the NCU identifies the rectifiers is by serial number (lowest serial number is Rect 1, next lowest is Rect 2, etc.). If you prefer the NCU to identify the rectifiers by position in the system, perform the following procedure.

Upon power up, the NCU arbitrarily assigns Feed AC1, AC2, or AC3 to each rectifier. This assignment is used to display rectifier AC input feed voltage(s). The User may reassign the feed to each rectifier per your specific installation by following the procedure below.

#### **Local Menu Navigation:**

None.

#### **Web Menu Navigation:**

Refer to the NCU Instructions (UM1M830BNA) for detailed instructions.

### **Configuring the NCU Identification of -48 VDC to +24 VDC Converters**

When -48 VDC to +24 VDC converters are all installed prior to applying power and starting the system, the order in which the NCU identifies the -48 VDC to +24 VDC converters is by serial number (lowest serial number is Conv 1, next lowest is Conv 2, etc.). If you prefer the NCU to identify the -48 VDC to +24 VDC converters by position in the system, perform the following procedure.

#### **Local Menu Navigation:**

None.

#### **Web Menu Navigation:**

Refer to the NCU Instructions (UM1M830BNA) for detailed instructions.

### **NCU Alarm Relay Check**

To verify operation of the external alarm relays, use the NCU alarm relay test feature. Refer to the NCU Instructions (UM1M830BNA) for instructions in using this feature.



**NOTE!** *The relays may be preprogrammed for specific functions. Refer to the configuration drawing (C-drawing) supplied with your system for your system's specific configuration.*

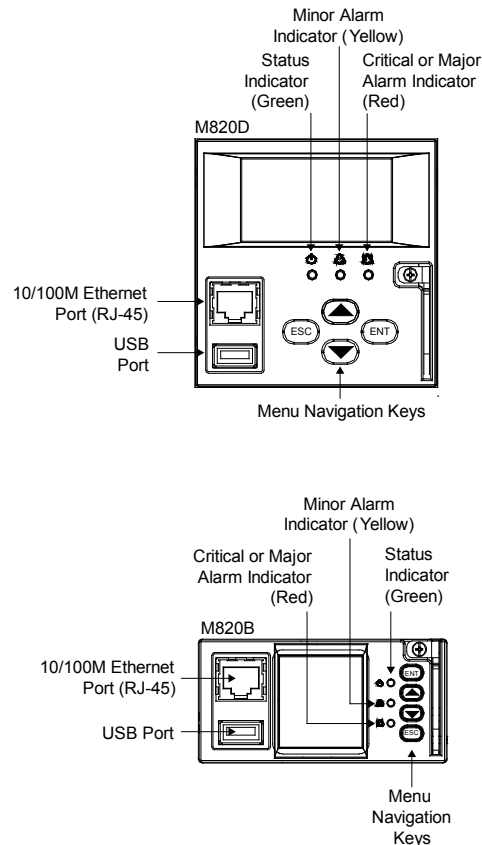
## ACU+ Controller Procedure

Refer to the ACU+ Instructions (UM1M820BNA) for detailed instructions.

### ACU+ Controller Initialization

Refer to **Figure 30** for locations of the ACU+ local indicators and navigation keys.

**Figure 30:** ACU+ Local Indicators and Navigation Keys



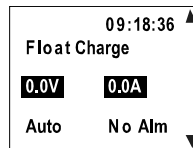
### Procedure

**NOTE!** The initialization routine takes several minutes. During that time various alarm indicators may illuminate on the ACU+ front panel and an audible alarm may sound. Disregard all alarms. An audible alarm can be silenced at any time by momentarily depressing the **ENT** key on the ACU+ Controller.

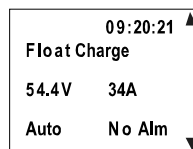
1. After the ACU+ is powered on, the display alternates between the “Logo” screen and a screen displaying “Advanced Control Unit Plus Version \*\*\*\*\* Starting...”
2. Next, the language screen appears. Press the up or down arrow key to select the desired language. Press the **ENT** key to confirm the selection. If no key is pressed within 10 seconds, the ACU+ selects the displayed language automatically.



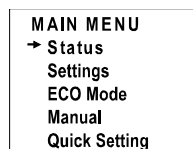
- As initialization continues, the Main screen is displayed, but with zero volts. Initialization is not complete.



- When initialization is complete, the Main screen displays voltage and current normally, and no alarms are active.



- System information is displayed in multiple screens. Repetitively press the up or down arrow key to view other system information screens one by one.
- From the Main screen, press **ENT** to go to the “Main Menu” screen.



- From the Main Menu, select a submenu by repetitively pressing the up or down arrow key. The selected submenu will be indicated by the cursor. Press **ENT** to open the submenu.



**NOTE!** Repeatedly press the “ESC” key to return in reverse order level by level from any submenu until the Main screen appears.

- Verify and set the ACU+ controller as required for your application. Refer to the ACU+ Instructions (UM1M820BNA) for procedures. Note that you will have to program the ACU+ for any temperature probes and external inputs/outputs connected to the IB2 Interface Board and EIB Extended Interface Board.




**NOTE!** When setting total rectifier current limit, the set point to each unit is the total set point divided by the number of units. For example, if the system contains five rectifiers and the current limit is set to 150 amps then each rectifier has a current limit set point of 30 amps. If one or more rectifiers are removed or fail it will take several seconds for the individual set points to the remaining rectifiers to be reset. In the example given, if one rectifier is removed the current limit set point will drop to 120 amps (30 amps times four remaining rectifiers) until the controller can send updated set points to the remaining rectifiers. This takes a couple communication cycles (several seconds) after which each rectifier would have a new set point of 37.5 amps for a total of 150 amps. The total current limit of the rectifiers should not be set such that the loss of the redundant rectifiers will cause this temporary set point to drop below the actual maximum expected load. If batteries are used on the rectifier output, the batteries should support the load until the current limit set points can be re-established due to loss of a rectifier.



## **Verifying the Configuration File**

Your ACU+ was programmed with a configuration file that sets all adjustable parameters. The version number of the configuration file can be found on the configuration drawing (C-drawing) that is supplied with your power system documentation, and on a label located on the ACU+. You can verify that the correct configuration file has been loaded into your ACU+ by performing the following procedure.


### **Procedure**

 **NOTE!** When viewing any of the following screens, if a key is not depressed within approximately 10 seconds, the ACU+ will automatically return to the Main screen.

1. With the Main screen displayed, press **ESC**. A screen displays the serial number and software version.
2. Press **ENT**. A screen displays the hardware version and MAC address.
3. Press **ENT**. A screen displays the configuration version number.
4. Press **ESC**, or wait approximately 10 seconds, to return to the Main screen.

## **Checking Basic System Settings**

Navigate through the controller menus and submenus to check system settings. You can adjust any parameter as required. Note that these settings can also be checked (and changed if required) via the WEB Interface.

 **NOTE!** Repeatedly press the “ESC” key to return in reverse order level by level from any submenu until the Main screen appears.

### **Procedure**

1. **To Select a Sub-Menu:**  
Press the UP or DOWN arrow keys to move the cursor up and down the list of sub-menus in the menu screen (selects the sub-menu), then press ENT to enter the selected sub-menu.
2. **To Select a User:**  
To select a User, use the UP or DOWN arrow keys to move the cursor to the Select User field. Press ENT. Use the UP and DOWN keys to select a User previously programmed into the ACU+. Press ENT to select the User. Note that only Users programmed into the ACU+ are shown. Users are programmed via the Web Interface. The default User is admin.
3. **To Enter a Password:**  
If a password screen opens, a password must be entered to allow the User to make adjustments. To enter a password, use the UP and DOWN keys to move the cursor to the Enter Password field. Press ENT. Use the UP and DOWN keys to choose a character. Press ENT to accept and move to the next character. Continue this process until all characters are entered. Press ENT again to accept the password. The default password is 1.
4. **To Change a Parameter:**  
Press the up or down arrow keys to move the cursor up and down the list of parameters in the menu screen (selects the parameter to change), then press ENT to change the selected parameter. The parameter field highlights. Press the up or down arrow keys to change the parameter value. Press ENT to confirm the change.

**Table 9** shows the menu navigation for some basic settings. Refer to the separate ACU+ Manual (UM1M820BNA) supplied with your power system for details and additional settings.

**Table 9:** ACU+ Basic Settings Menu Navigation

Parameter	Menu Navigation
Date	Main Menu / Settings / Controller / Date
Time	Main Menu / Settings / Controller / Time
IP Communications Parameters (IP address, subnet mask address, gateway address)	Main Menu / Settings / Communication
Float Voltage	Main Menu / Settings / Battery / Charge / Float Voltage
Equalize Voltage	Main Menu / Settings / Battery / Charge / EQ Voltage
Battery Capacity	Main Menu / Settings / Battery / Battery 1 / Rated Capacity
BTRM Feature	Main Menu / Settings / Battery / Basic / BTRM Action Main Menu / Settings / Battery / Basic / BTRM Voltage
Temperature Compensation Center Temperature	Main Menu / Settings / Battery / Temp Comp / Temp CompCenter
Temperature Compensation Slope	Main Menu / Settings / Battery / Temp Comp / Temp Comp Coeff
Temperature Compensation Sensor	Main Menu / Settings / Battery / Temp Comp / TempComp Sensor
Temperature Compensation Maximum Voltage	Main Menu / Settings / Battery / Temp Comp / Temp Comp Max V
Temperature Compensation Minimum Voltage	Main Menu / Settings / Battery / Temp Comp / Temp Comp Min V
HVSD Limit	Main Menu / Settings / Rectifier / All Rect Set / HVSD Limit
Rectifier Current Limit	Main Menu / Settings / Rectifier / All Rect Set / Curr Limit Pt
Over Voltage Alarm 1	Main Menu / Settings / Power System / General / Over Voltage 1
Over Voltage Alarm 2	Main Menu / Settings / Power System / General / Over Voltage 2
Under Voltage Alarm 1	Main Menu / Settings / Power System / General / Under Voltage 1
Under Voltage Alarm 2	Main Menu / Settings / Power System / General / Under Voltage 2

### **Changing Battery Capacity Rating in the ACU+**

Change the battery capacity setting of the ACU+ to match the battery connected to the power system.

#### **Local Menu Navigation:**

Main Menu / Settings / Battery / Battery # / Rated Capacity.

#### **WEB Menu Navigation:**

Device Information / Battery Group / Battery # / select the Settings Tab and enter the Battery Rating parameter.

Refer to the ACU+ Instructions (UM1M820BNA) for detailed instructions.

### **Configuring the ACU+ Identification of Rectifier Modules and Assigning which Input Phase is Connected to the Rectifiers**

When rectifiers are all installed prior to applying power and starting the system, the order in which the ACU+ identifies the rectifiers is by serial number (lowest serial number is Rect 1, next lowest is Rect 2, etc.). If you prefer the ACU+ to identify the rectifiers by position in the system, perform the following procedure.

Upon power up, the ACU+ arbitrarily assigns Phase A, B, or C to each rectifier. This assignment is used to display rectifier AC input phase voltage(s). The User may reassign the phase to each rectifier per your specific installation by following the procedure below.

#### **Local Menu Navigation:**

Main Menu / Settings / Rectifier / Rect #1 / Rectifier ID and Rect Phase.  
(repeat for every rectifier)  
then  
Main Menu / Manual / Rectifier / All Rect Ctrl / Confirm ID/PH.

#### **WEB Menu Navigation:**

Device Information / Rectifier Group / Rectifier #1 / Settings Tab / Rectifier ID and Rectifier Phase.  
(repeat for every rectifier)  
then  
Device Information / Rectifier Group / Control Tab / Confirm Rectifier "ID/Phase".

Refer to the ACU+ Instructions (UM1M820BNA) for detailed instructions.

### **Configuring the ACU+ Identification of -48 VDC to +24 VDC Converters**

When converters are all installed prior to applying power and starting the system, the order in which the ACU+ identifies the converters is by serial number (lowest serial number is Conv 1, next lowest is Conv 2, etc.).

If you prefer the ACU+ to identify the converters by position in the system, perform the following procedure.

#### **Local Menu Navigation:**

Main Menu / Settings / Converter / Conv #1 / Set Conv ID.  
(repeat for every converter)  
then  
Main Menu / Manual / Converter / All Conv Ctrl / Confirm ID.

#### **WEB Menu Navigation:**

Device Information / Converter Group / Converter #1 / Settings Tab / Set Converter ID.  
(repeat for every converter)  
then  
Device Information / Converter Group / Control Tab / Confirm Converters ID.

Refer to the ACU+ Instructions (UM1M820BNA) for detailed instructions.

### **ACU+ Alarm Relay Check**

To verify operation of the external alarm relays, use the ACU+ alarm relay test feature. Refer to the ACU+ Instructions (UM1M820BNA) for instructions in using this feature.















**NOTE!** The relays may be preprogrammed for specific functions. Refer to the configuration drawing (C-drawing) supplied with your system for your system's specific configuration.

## Checking System Status

### Procedure

1. Observe the status of the indicators located on the controller, rectifiers, and converters (if furnished). If the system is operating normally, the status of these is as shown in **Table 10**.

**Table 10:** Status and Alarm Indicators

Component	Indicator		Normal State
NCU		Status (Green)	On
		Minor (Yellow)	Off
		Critical or Major Alarm (Red)	Off
ACU+		Status (Green)	On
		Minor (Yellow)	Off
		Critical or Major Alarm (Red)	Off
Rectifier Modules		Power (Green)	On
		Protection (Yellow)	Off
		Alarm (Red)	Off
Converter Modules		Power (Green)	On
		Protection (Yellow)	Off
		Alarm (Red)	Off

## **Final Steps**

1. If any controller configuration settings were changed, refer to the Controller Instructions (UM1M820BNA or UM1M830BNA) and save a copy of the configuration file. This file can be used to restore the controller settings, if required, at a later date.
  - Note that provided on a USB drive furnished with the system is a controller configuration drawing (C-drawing) and the controller configuration files loaded into the controller as shipped.
2. Verify all rectifier and converter modules and the controller are fully seated, latched, and the latch handle screws secured.
3. Verify there are no external alarms and the local indicators are as shown in **Table 10**.

