



XDU070 Coolant Distribution Unit (Liquid to Air)

Installation and Commissioning Guide

The information contained in this document is subject to change without notice and may not be suitable for all applications. While every precaution has been taken to ensure the accuracy and completeness of this document, Vertiv assumes no responsibility and disclaims all liability for damages resulting from use of this information or for any errors or omissions.

Vertiv recommends installing a monitored fluid detection system that is wired to activate the automatic closure of field installed coolant fluid supply and return shut off valves, where applicable, to reduce the amount of coolant fluid leakage and consequential equipment and building damage. Refer to local regulations and building codes relating to the application installation, and operation of this product. The consulting engineer, installer and/or end user is responsible for compliance with all applicable laws and regulations relating to the application, installation, and operation of this product.

The products covered by this instruction manual are manufactured and/or sold by Vertiv. This document is the property of Vertiv and contains confidential and proprietary information owned by Vertiv. Any copying, use, or disclosure of it without the written permission of Vertiv is strictly prohibited.

Names of companies and products are trademarks or registered trademarks of the respective companies. Any questions regarding usage of trademark names should be directed to the original manufacturer.

Technical Support Site

If you encounter any installation or operational issues with your product, check the pertinent section of this manual to see if the issue can be resolved by following outlined procedures.

Visit <https://www.vertiv.com/en-us/support/> for additional assistance.

TABLE OF CONTENTS

1 Important Safety Instructions	1
1.1 General	4
1.2 Installation and Handling	4
1.3 Application	4
1.4 Warranty	5
1.5 Electrical Connection	5
1.6 Replacement Parts	5
1.7 Waste Disposal	5
1.8 Documentation	5
2 Agency	7
2.1 Product Standards and Approvals	7
2.2 RoHS 3 Compliance	7
3 Product Description	9
3.1 General	9
3.2 Vertiv™ XDU070 Model Number Nomenclature	10
3.3 Product Views	11
4 Technical Data	15
4.1 Weights and Dimensions	15
4.2 Pipe Connections	15
4.3 Fluid Circuit	15
4.4 Fluid Circuit Volume	17
4.5 Electrical Data	17
4.6 Noise	17
5 Installation	19
5.1 Unloading and Positioning	19
5.2 Preparing the XDU070 for Operation	23
5.3 Pipe Connections	26
5.4 Electrical	29
5.4.1 Power Wiring	29
5.4.2 EMC Wiring	32
5.5 Communications	32
5.5.1 Ethernet Connections	32
5.6 Pre-Commissioning Checks	32
5.6.1 Site Check	32
5.6.2 Mechanical Installation Check	33
5.6.3 Electrical Installation Check	33
5.6.4 Secondary Fluid Specification	34

6 Commissioning	35
6.1 Unit Configuration	35
6.1.1 Fluid Circuit	35
6.1.2 Pipework Connections	35
6.1.3 Circuit Filling	35
6.1.4 Expansion Vessel Venting	38
6.2 Fluid Circulation	39
6.2.1 Low Speed Circulation	39
6.2.2 Normal Circulation	40
6.3 Fan Operation	40
6.4 Subsequent Filling	40
Appendices	41
Appendix A: Technical Support and Contacts	41
Appendix B: Piping Schematic	43
Appendix C: Warranty Details	45
Appendix D: Notes	47
Appendix E: Disposal Information	49

1 Important Safety Instructions

Save These Instructions

This manual contains important instructions that should be followed during operation and maintenance of the Vertiv™ XDU070.



WARNING! Risk of improper wiring, piping, moving, lifting, and handling. Can cause serious injury or death. Building and equipment damage may also result. Installation and service of this equipment should be done only by qualified personnel who have been specially trained in the installation of air conditioning equipment and who are wearing appropriate, OSHA approved PPE.



WARNING! Risk of improper moving. Can cause serious injury or death. Building and equipment damage may also result. Use only lifting equipment that is rated for the unit weight by an OSHA certified rating organization. Shipping weights and unit weights are listed in [Weights and Dimensions](#) on page 15.



WARNING! Risk of top-heavy unit falling over when improperly lifted or moved. Can cause serious injury or death. Building and equipment damage may also result. Read all of the following instructions and verify that all lifting and moving equipment is rated for the weight of the unit before attempting to move, lift, remove packaging from or prepare the unit for installation. Unit weights are specified in [Weights and Dimensions](#) on page 15.



WARNING! Risk of unsecured unit rolling off pallet. Can cause serious injury or death. Building and equipment damage may also result. The unit is on casters. Ensure that the unit and pallet are located on a flat surface before loosening the hardware securing the unit to its shipping pallet.

See [Unloading and Positioning](#) on page 19.



WARNING! This product is supplied with a 21.7 psi (1.5 bar) nitrogen holding charge in the fluid circuit, which will need to vented during the installation process, see [Fluid Circuit](#) on page 15 for more information.

See [Preparing the XDU070 for Operation](#) on page 23.



WARNING! This unit is powered by high voltage. Serious injury or death can occur. All electrical work must only be carried out by a suitably qualified electrician. Installation should include a locally mounted isolator/switch disconnect to enable safe maintenance of the unit (to be supplied by others).



WARNING! Arc flash and electric shock hazard. Can cause serious injury or death. Building and equipment damage may also result. Disconnect all local and remote electric power supplies and wear appropriate, OSHA approved personal protective equipment (PPE) per NFPA 70E before working within the electric control enclosure. Customer must provide earth ground to unit, per NEC, CEC, and local codes, as applicable.

Verify with a voltmeter that power is Off. The controller does not isolate power from the unit, even in the Unit Off mode. Some internal components still require and receive power even during the unit off mode of the controller. The factory supplied, optional disconnect switch is inside the unit. The line side of this switch contains live high voltage. The only way to ensure that there is NO voltage inside the unit is to install and open a remote disconnect switch. Refer to unit electrical schematic.

Before proceeding with installation, read all instructions, verify that all the parts are included and check the nameplate to be sure the voltage matches available utility power. Follow all local codes.



WARNING! Risk of electric shock. Can cause serious injury or death. Building and equipment damage may also result. Open all local and remote electric power supply disconnect switches and verify that power is off with a voltmeter before working within any electric connection enclosures. The controller does not isolate power from the unit, even in the unit off mode. Some internal components require and receive power even during the unit off mode of the controller.

Installation, service, and maintenance work must be performed only by properly trained and qualified personnel and in accordance with applicable regulations and manufacturers' specifications. Opening or removing the covers to any equipment may expose personnel to lethal voltages within the unit even when it is apparently not operating and the input wiring is disconnected from the electrical source.



WARNING! Risk of short circuits and electric shock. Can cause serious injury or death. Building and equipment damage can result from cut insulation or damaged wires. Can cause overheated wiring, smoke, fire, activation of fire suppression systems and EMS personnel, and loss of power to fans. Verify that all wiring connections are tight and that all wiring is contained within the junction box prior to closing and securing the cover.

Insert CSA certified or UL listed bushings into holes and/or knockouts used to route wiring through metal panels to protect the wire insulation from contact with sheet metal edges.



WARNING! Risk of improper wire sizing/rating and loose electrical connections causing overheated wire and electrical connection terminals resulting in smoke or fire. Can cause serious injury or death. Building and equipment damage may also result. Use correctly sized copper wire only and verify that all electrical connections are tight before turning power On. Check all electrical connections periodically and tighten as necessary.

See [Power Wiring](#) on page 29.



CAUTION: Risk of improper handling heavy and lengthy parts. Can cause injury. Building and equipment damage may also result. Cabinet panels can exceed 5 ft. (1.5 m) in length and weigh more than 35 lb. (15.9 kg). Follow relevant OSHA lifting recommendations and consider using a two-person lift for safe and comfortable removal and installation of cabinet panels. Only properly trained and qualified personnel wearing appropriate, OSHA-approved PPE should attempt to remove or install cabinet panels.



CAUTION: Risk of contact with sharp edges, splinters, and exposed fasteners. Can cause injury. Only properly trained and qualified personnel wearing appropriate, OSHA approved PPE should attempt to move, lift, remove packaging from or prepare the unit for installation.



CAUTION: The Vertiv™ XDU070 is a heavy piece of equipment and a minimum of two operatives will be required to carry out the unloading task safely. If positioned on a raised floor, adequate under floor supports should be installed to bear the weight of the unit. A minimum free area of 6.6 ft. x 19.7 ft. (2 m x 6 m) should be allowed when unloading this product from the crate.

See [Unloading and Positioning](#) on page 19.

NOTICE

Risk of passageway interference. Can cause unit and/or structure damage. The unit may be too large to fit through a passageway while on or off the skid. Measure the unit and passageway dimensions and refer to the installation plans prior to moving the unit to verify clearances.

NOTICE

Risk of damage from forklift. Can cause unit damage. Keep tines of the forklift level and at a height suitable to fit below the skid and/or unit to prevent exterior and/or underside damage.

NOTICE

Risk of improper storage can cause unit damage. Keep the unit upright, indoors and protected from dampness, freezing temperatures and contact damage.

NOTICE

Ensure all drain valves have been closed after venting nitrogen.

NOTICE

Risk of improper power supply connection. Can cause equipment damage and loss of warranty coverage.

Prior to connecting any equipment to a main or alternate power source (for example backup generator systems) for startup, commissioning, testing, or normal operation, ensure that these sources are correctly adjusted to the nameplate voltage and frequency of all equipment to be connected. In general, power source voltages should be stabilized and regulated to within $\pm 5\%$ of the load nameplate nominal voltage. Also, ensure that no three phase sources are single phased at any time.

See transformer label for primary tap connections. Installer will need to change transformer primary taps if applied unit voltage is other than pre-wired tap voltage.

NOTICE

Risk of improper electrical connection of three phase input power. Can cause backward pump rotation and unit damage. Service technicians should use a gauge set on the system during the initial startup to verify that the three phase power is connected properly. Three phase power must be connected to the unit line voltage terminals in the proper sequence so that the pump rotates in the proper direction. Incoming power must be properly phased to prevent pump from running backward. We recommend checking the unit's phasing with proper instrumentation to ensure that the power connections were made correctly. We also recommend verifying discharge and suction pressures during startup to ensure that the pumps are running in the correct direction.

NOTICE

This equipment is required to be installed only in locations not accessible to the general public. Installation, service, and maintenance work must be performed only by properly trained and qualified personnel and in accordance with applicable regulations and manufacturer's specifications.

1.1 General

Mechanical and electrical equipment such as Coolant Distribution Units (CDUs) present potential mechanical and electrical hazards. All safety, installation, operation and maintenance instructions must be adhered. Any work on or use of the equipment must only be carried out by technically competent personnel who are fully trained. This product is designed to minimize all potential hazards by restricting access through unit casings, doors and covers while equipment is operational.

Before any maintenance work being carried out, ensure:

1. Equipment is switched OFF.
2. Equipment and controls are disconnected from the electrical supply.
3. All rotating parts such as pumps and fans have come to rest.

If in any doubt over anything regarding safety, installation, operation or maintenance instructions, it is essential that the manufacturer, their agent or appointed representative is consulted for clarification and advice.

1.2 Installation and Handling

Installation and operation must be conducted in accordance with local and national regulations and normal codes of good practice. When moving or lifting the product, caution must be observed to ensure the safety of personnel. Only the appropriate lifting equipment must be used.



WARNING! This product is supplied with a 21.7 psi (1.5 bar) nitrogen holding charge in the fluid circuit, which will need to vented during the installation process. Refer to Fluid Circuit on page 15 for more information.

1.3 Application

This product is to be used indoors only and must be only used for the application it was designed for. This product must not be used in a hazardous environment.

1.4 Warranty

Failure to comply with Vertiv's installation, maintenance and operation instructions may affect the reliability and performance of the unit and invalidate any warranty.

1.5 Electrical Connection



WARNING! This unit is powered by high voltage. Serious injury or death can occur. Power supplied to this product must be provided with an external means of isolation.

Electrical connections should be carried out in accordance with local and national regulations by a qualified electrician. Never make any electrical connections inside, or to the unit unless the electricity supply has been switched OFF at the disconnect (isolator).

1.6 Replacement Parts

Any parts replaced during maintenance or servicing must be the same specification as those being replaced and should only be obtained from Vertiv.

The use of incorrect replacement parts may affect the operation or reliability of the unit and invalidate any warranty.

1.7 Waste Disposal

Any waste or single use materials must be disposed of in a responsible manner and in strict adherence to local and national environmental regulations. For details, consult local environmental agencies.

1.8 Documentation

Operation and maintenance documentation together with commissioning, maintenance or service records must always remain with the unit.

This page intentionally left blank

2 Agency

2.1 Product Standards and Approvals

Vertiv products installed and operated in compliance with this document, the operation and maintenance guide and installation and commissioning guide, conform to the Low Voltage directive 2014/35/EU, the EMC directive 2014/30/EU and the Pressure Equipment directive 2014/68/EU. As manufactured, Vertiv products are designed to comply with an IP21 rating. This product is cULus listed for the appropriate voltage models and certificates will be made available on request (cULus certificate pending).



2.2 RoHS 3 Compliance

Vertiv certifies that all products manufactured and supplied by Vertiv are fully RoHS compliant in accordance with EU RoHS Directives EU 2015/863.



This page intentionally left blank

3 Product Description

3.1 General

This document describes the physical and electrical characteristics of the Vertiv™ XDU070 for installation and commissioning purposes.

The XDU070 contains a secondary closed loop circuit that provides a supply of cooling fluid to IT equipment for direct cooling (such as cold plates at chip level).

The fluid circuit is a low pressure sealed system with the heat removed from the high heat density areas of IT equipment rejected to ambient air via a low pressure drop cooling coil heat exchanger, arranged in a V-format with fan assistance provided by 7 x axial fans.

The fluid circuit ensures that the cooling fluid in a data center environment can be kept to a minimum volume, is closely controlled for flow, pressure and temperature and can be accurately maintained for fluid quality (with included filtration).

The primary cooling source will be the ambient air of the data center, and final heat transfer will depend on the air temperature and flow rate.

- Maximum secondary fluid flow rate is 32 gpm (120 l/m)
- 60 kW to 100 kW capacity dependent on ambient operating conditions (approach temperature difference), fan speed, and fluid type
- 1.5 in. hygienic outlet and inlet connections, compatible with PG-25 or water working fluid
- Expansion tank and integrated air vents within fluid circuit
- Approved wetted materials for direct to chip applications
- Fan redundancy (N+1), pump redundancy and field replaceable
- Designed to ASHRAE Liquid Cooling Class W4
- Designed to ASHRAE Air Cooling Class A2 upper limits
- Integrated 50 micron filters (with hot swap function)
- Max airflow approaching 6,533 CFM (11,100 CMH)
- Top and bottom fluid connection, 10 liter stainless steel fluid reservoir and integrated fill pump
- Ability to implement liquid cooling solutions without the need for a primary water supply or other related infrastructure
- Easy installation, maintenance, and retrofit of pipework parts
- Small footprint: 2300 mm x 600 mm x 1200 mm (91 in. x 24 in. x 48 in.)
- Black textured finish to blend in with computer room environment
- International service team to provide professional and all in one services from installation to maintenance and troubleshooting

3.2 Vertiv™ XDU070 Model Number Nomenclature

The XDU070 can be configured for voltage options to suit:

- Any global location
- Secondary filtration
- Secondary top/bottom connections

Table 3.1 below is an example of the XDU070 model number, fully configured. **Table 3.2** below describes each digit of the model number.

Table 3.1 XDU070 Model Number

Digit	1	2	3	4	5	6	7	8	9	10	11	12	13	14	15
Model #	X	D	U	0	7	0	A	0	K	3	1	0	2	0	A

Table 3.2 XDU070 Nomenclature Detail

Digit	Feature	Value	Description
1 - 3	Family Name	XDU	Product family
4 - 6	Unit Model	070	Model
7	Cooling Type	A	Liquid to air
8	Place Holder	0	None
9	Voltage Selection	K	120 V - 1 PH - 60 Hz
		S	220 V - 1 PH - 50 Hz
10	PRV	3	3 bar
		4	4 bar
11	Monitoring	1	Standard
12	Connection Adapter	0	None
13	Secondary Filtration	1	Factory Fitted (25 micron)
		2	Factory Fitted (50 micron)
14	Placeholder	0	None
15	Configuration	A - Z	Standard Configuration
		S	Special feature authorization

3.3 Product Views

Figure 3.1 Front View of Vertiv™ XDU070 (Doors and Side Panels Removed)

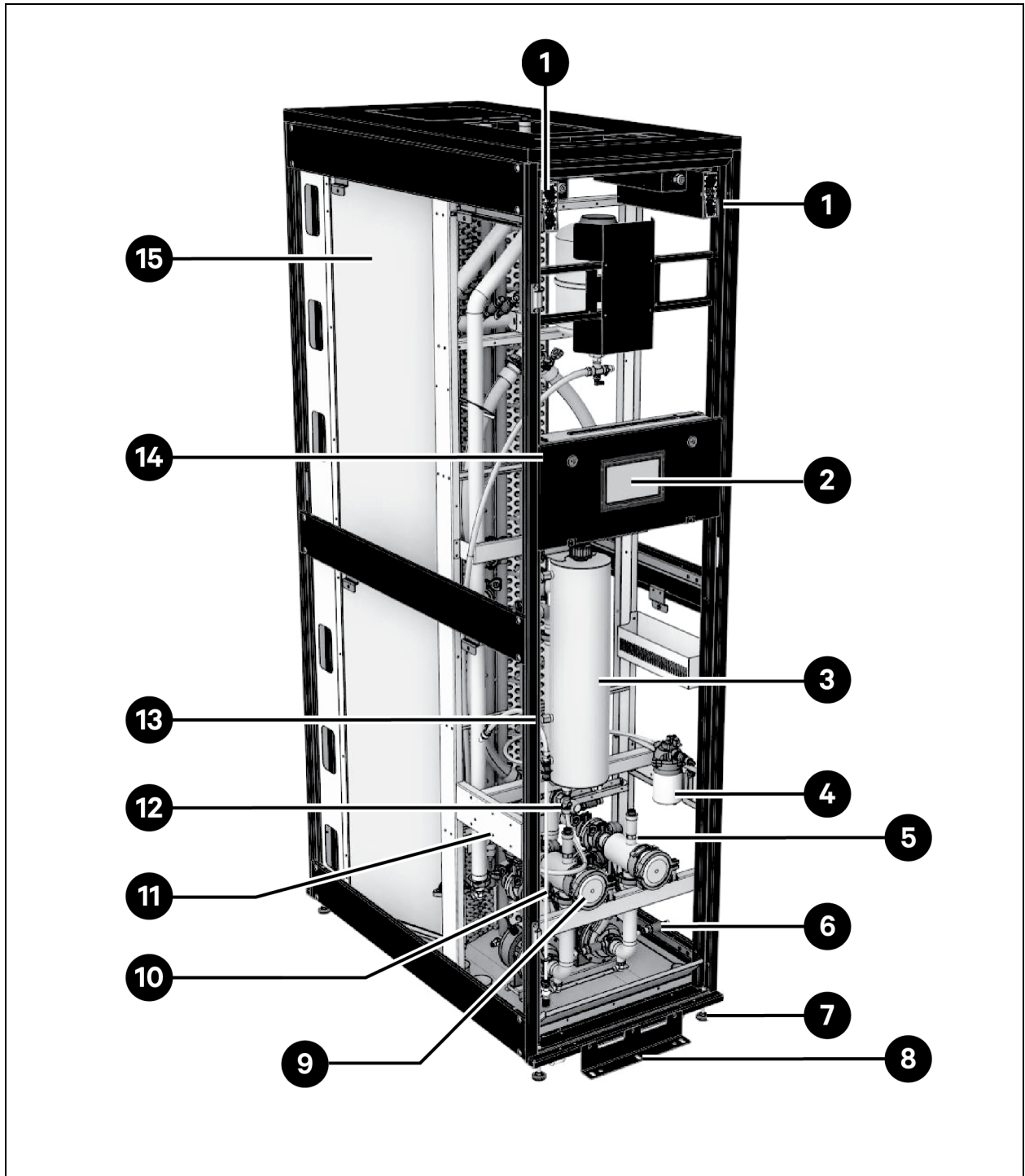

Item	Description
1	Redundant 48 VDC power supply (A and B)
2	Touchscreen display
3	Reservoir tank (2.16 gal/10 liters)
4	Fill pump P4 (reservoir tank)
5	Automatic air vents on filter
6	Pressure sensors (quantity is 7)
7	Wheels and adjustable feet
8	Tie down bracket (front and back)
9	Secondary fluid circuit filters 50 micron
10	Filling wand
11	Fill pump P3 (System)
12	Pressure relief valve 43.5 psi (3 bar)
13	Level sensors (3 Sensors in reservoir tank) (1Sensor in pipework)
14	Control panel
15	Cooling coil

Figure 3.2 Rear View of Vertiv™ XDU070 Coolant Distribution Unit (Liquid to Air) (Doors and Side Panels Removed)

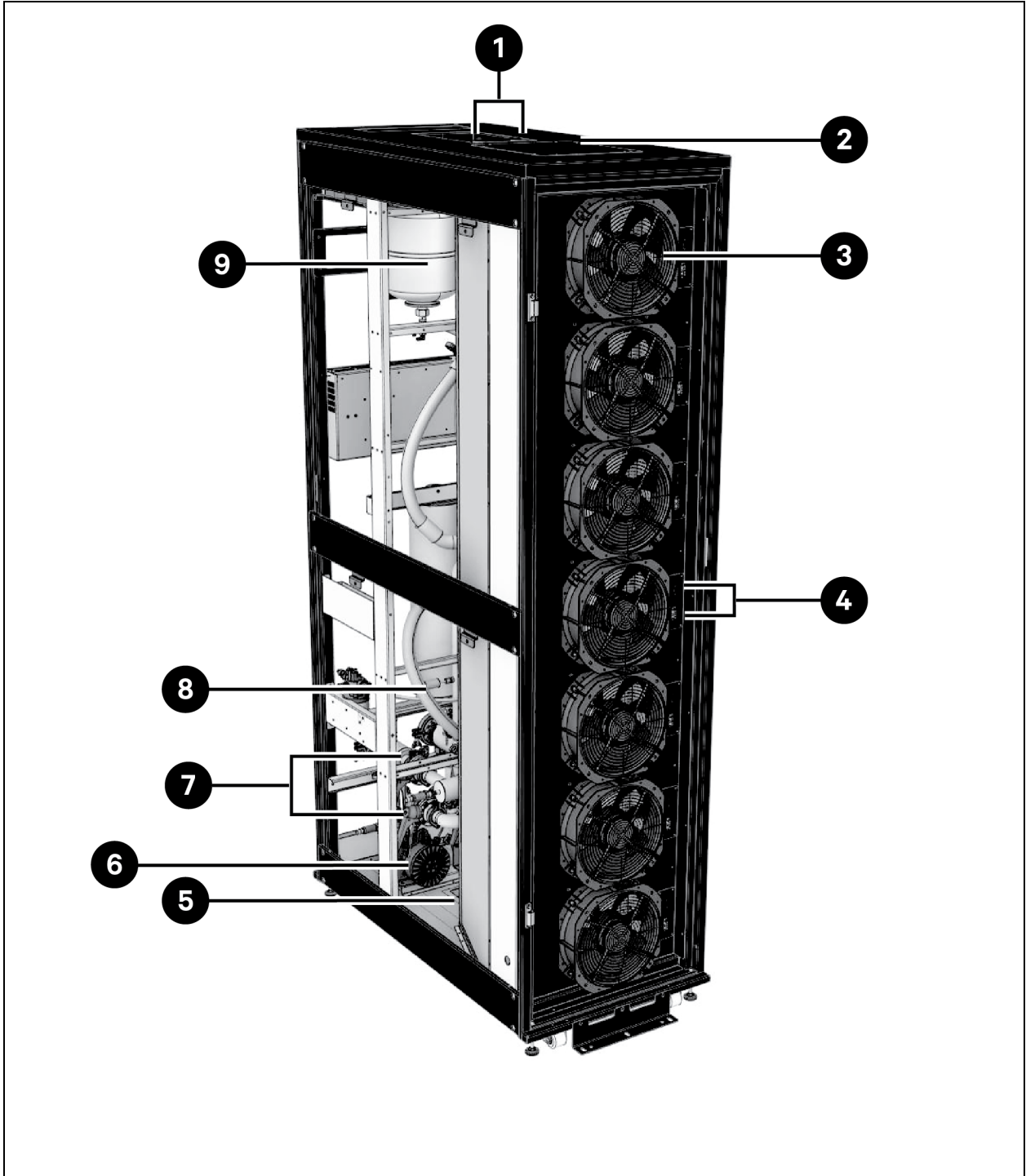

Item	Description
1	Automatic air vents (on coil headers)
2	Access panel to 48 VDC distribution busbar and fuses
3	Axial fans 48 VDC (quantity is 7)
4	Fan fuse and connector
5	Dip tray with float switch
6	Secondary fluid circuit pumps P1 and P2 (with built in speed control)
7	Filter/pump isolation valves
8	Flow sensor
9	Expansion vessel

4 Technical Data

4.1 Weights and Dimensions

Dimensions	Width		Height		Depth	
Unit	in.	mm	in.	mm	in.	mm
Standard Cabinet	23.6	600	90.6	2,300	47.2	1,200
Shipping	39.4	1,000	94.5	2,400	55.1	1,400
Weight	Dry		Operating		Shipping	
Unit	lbs.	kg	lbs.	kg	lbs.	kg
Standard Cabinets	899	408	1,007	457	1,234	560
Fluid Circuit Data	Gallons			Liters		
Base Unit	10.3			39		
Reservoir Tank Capacity	2.6			10		
Piping Connection Top or Bottom	1.5 in. Sanitary flange					
Water Filtration	50 micron (Standard)					
Fan Data	CFM			CMH		
Max airflow 6 Fan Operation (N + 1)	5,945			10,100		
Max airflow 7 Fan Operation (N)	6,533			11,100		
Noise Level at 3 m (10 ft.)	<72 dBA (Sound Pressure)					

4.2 Pipe Connections

Pipe connections for the secondary fluid circuit are made on either the top or bottom of the cabinet and is field fitted.

Fluid IT circuit is 1.5 in. (38.1 mm) sanitary flanges.

4.3 Fluid Circuit

Figure 4.1 on the next page shows the pressure/flow differential available at the fluid supply and return connections of the Vertiv™ XDU070 based on water for both single and twin pump operation.

Figure 4.1 Available Fluid External Pressure/Flow

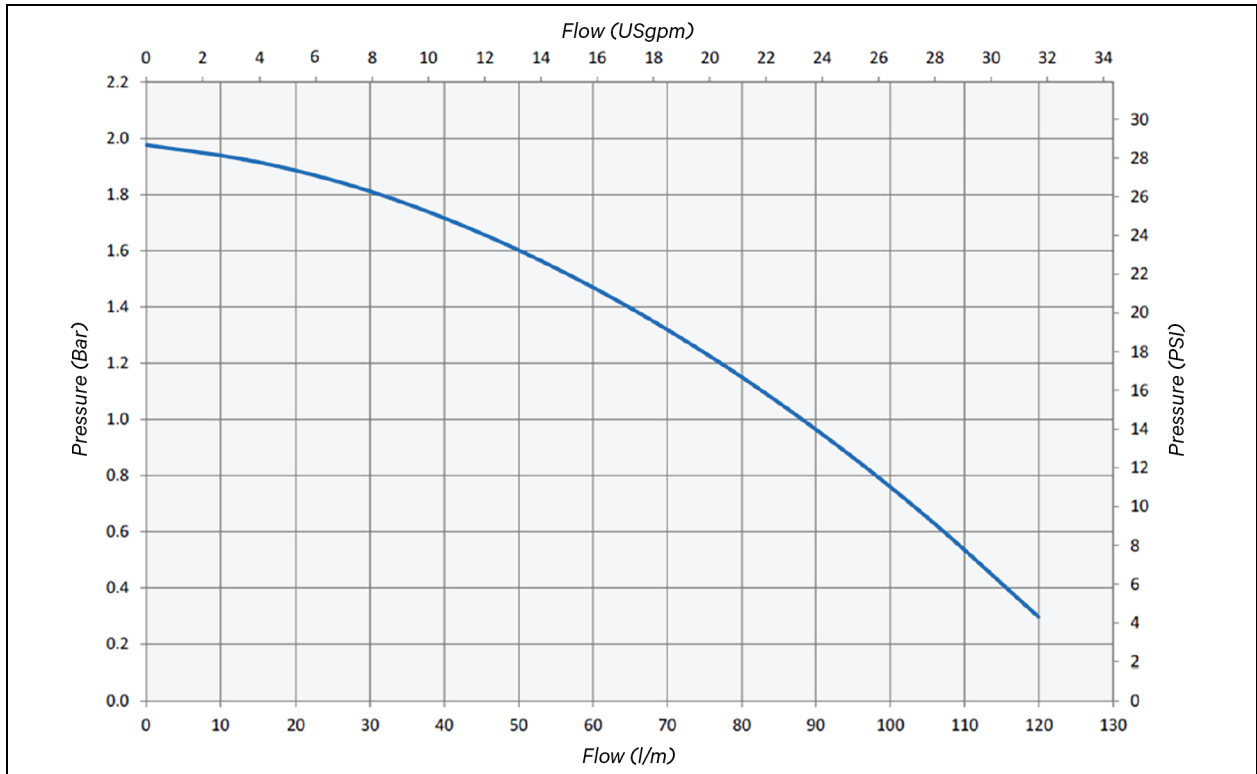
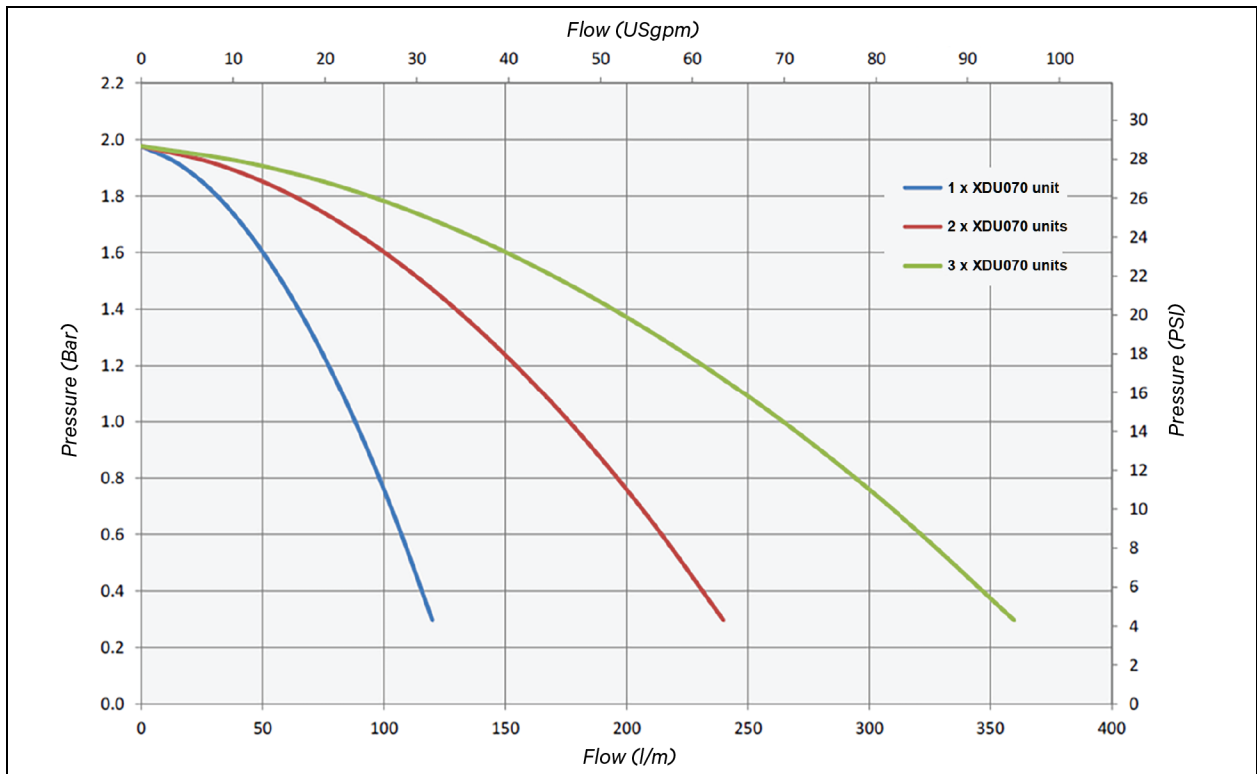

Figure 4.2 Pressure/Flow Graph for Multiple Units in Parallel



NOTE: If the Vertiv™ XDU070 unit count is greater than eight, contact the factory for performance data.

4.4 Fluid Circuit Volume

The fluid IT circuit has a capacity of 2.6 gallons (49 liters), including a 10 liter reservoir tank.

4.5 Electrical Data

Table 4.1 Supported Electrical Supplies

Single/Dual Pump Operation						
	FLA	MCA	OPD	Full Load Current (FLC)	Minimum Circuit Ampacity (MCA)	Maximum Overcurrent Protection (MOP)
230 V - 1 ph - 50 Hz	8	20	32	8 A	20 A	30 A
115 V - 1 ph - 60 Hz	16	24	40	16 A	24 A	40 A
Dual Power Feeds (ATS)	Standard Feature					
Max. Installed Load	3.91 kVA					
Agency Approvals and Certification	CE, cULus, RoHS					
Operating Conditions	0 °F to 104 °F (0 °C to 40 °C) ambient 10% to 90% RH (non-condensing)					
Storage Conditions	-40 °F to 158 °F (-40 °C to 70 °C) 5% to 93% RH (non-condensing)					

4.6 Noise

Maximum sound power level is 72 dBA

This page intentionally left blank

5 Installation

5.1 Unloading and Positioning



WARNING! Risk of improper wiring, piping, moving, lifting, and handling. Can cause serious injury or death. Building and equipment damage may also result. Installation and service of this equipment should be done only by qualified personnel who have been specially trained in the installation of air conditioning equipment and who are wearing appropriate, OSHA approved PPE.



WARNING! Risk of improper moving. Can cause serious injury or death. Building and equipment damage may also result. Use only lifting equipment that is rated for the unit weight by an OSHA certified rating organization. Shipping weights and unit weights are listed in [Weights and Dimensions](#) on page 15.



WARNING! Risk of top heavy unit falling over when improperly lifted or moved. Can cause serious injury or death. Building and equipment damage may also result. Read all of the following instructions and verify that all lifting and moving equipment is rated for the weight of the unit before attempting to move, lift, remove packaging from or prepare the unit for installation. Unit weights are specified in [Weights and Dimensions](#) on page 15.



WARNING! Risk of unsecured unit rolling off pallet. Can cause serious injury or death. Building and equipment damage may also result. The unit is on casters. Ensure that the unit and pallet are located on a flat surface before loosening the hardware securing the unit to its shipping pallet.



CAUTION: Risk of improper handling heavy and lengthy parts. Can cause injury. Building and equipment damage may also result. Cabinet panels can exceed 5 ft. (1.5 m) in length and weigh more than 35 lb. (15.9 kg). Follow relevant OSHA lifting recommendations and consider using a two person lift for safe and comfortable removal and installation of cabinet panels. Only properly trained and qualified personnel wearing appropriate, OSHA approved PPE should attempt to remove or install cabinet panels.



CAUTION: Risk of contact with sharp edges, splinters, and exposed fasteners. Can cause injury. Only properly trained and qualified personnel wearing appropriate, OSHA approved PPE should attempt to move, lift, remove packaging from or prepare the unit for installation.

NOTICE

Risk of passageway interference. Can cause unit and/or structure damage. The unit may be too large to fit through a passageway while on or off the skid. Measure the unit and passageway dimensions and refer to the installation plans prior to moving the unit to verify clearances.

NOTICE

Risk of damage from forklift. Can cause unit damage. Keep tines of the forklift level and at a height suitable to fit below the skid and/or unit to prevent exterior and/or underside damage.

NOTICE

Risk of improper storage can cause unit damage. Keep the unit upright, indoors and protected from dampness, freezing temperatures and contact damage.

On arrival at the site, the Vertiv™ XDU070 crate should be placed on a level solid surface to safely unload the unit from the crate.

Check the crate for any signs of transit damage and ensure that the tilt labels have not been activated (any serious damage must be reported to the manufacturer and shipper immediately, prior to unpacking).

The crate has been designed with a hinge down the front panel to allow the XDU070 to be easily wheeled off the pallet to floor level.



CAUTION: The XDU070 is a heavy piece of equipment and a minimum of two operatives will be required to carry out the unloading task safely. If positioned on a raised floor, adequate under floor supports should be installed to bear the weight of the unit. A minimum free area of 6.6 ft. x 19.7 ft. (2 m x 6 m) should be allowed when unloading this product from the crate.

To remove the XDU070 from the crate, follow the steps below and see **Figure 5.2** on page 22.

1. Unscrew and lower the front door of the crate to ground level.
2. Remove the three large battens from inside the crate and position them under the crate door for support.
3. Take out the smaller batten from inside the crate and insert it into the gap between the crate floor and the hinged down corner.
4. Unscrew and detach the crate roof panel.
5. Remove the front cross batten by unscrewing it.
6. Unscrew the front tie down bracket from the crate floor and detach the bracket from XDU070.

Figure 5.1 Preparing to Unload the Vertiv™ XDU070 Unit from the Crate

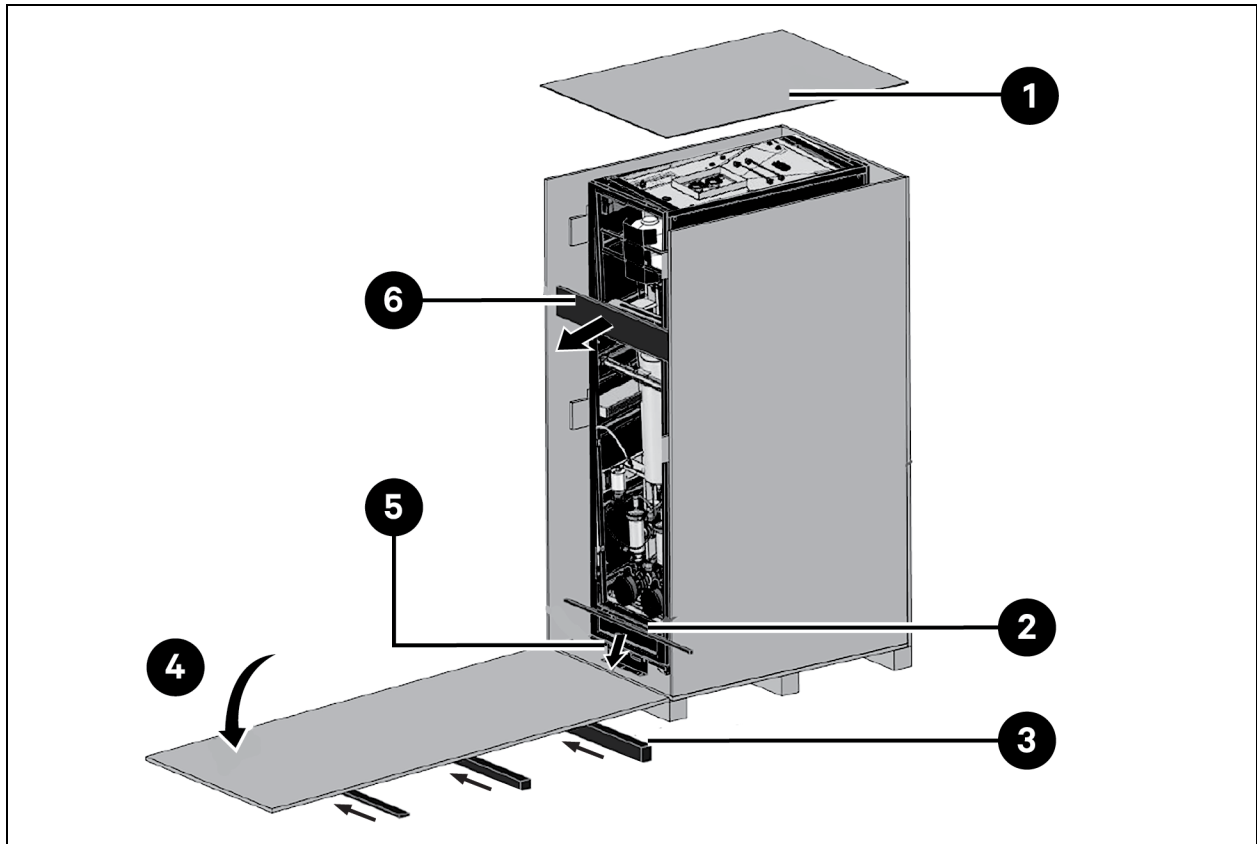

Item	Description
1	Crate roof panel
2	Small batten
3	Large batten
4	Crate Front Door
5	Front tie down bracket
6	Cross batten

NOTE: Panels do not come attached, as shown in Figure 5.1 above.

Three wooden support blocks are provided inside the crate, which should be removed and placed under the lower down panel to provide necessary support prior to wheeling the XDU070 out, along with an infill strip to fill in the gap between door and pallet. The top of the crate will also need to be removed prior to wheeling the unit out. Slowly wheel out the unit on level floor. Remove protective bubble wrap from the unit. Inspect the unit for any transit damage. Damage found must be reported to the manufacturer immediately and prior to installation.

The XDU070 can be maneuvered into position on the supplied load bearing wheels and once in its final location, may be secured, raised and leveled using the built-in jacking feet. The keys for the front and rear doors are supplied in a bag tied to the inside of the front door.

The XDU070 is intended to be positioned on a smooth, level solid or raised floor.

Space should be allowed at the front and rear of the unit in excess of 24 in. (600 mm) to allow the access doors to be fully opened.

Figure 5.2 Unloading the XDU070 Unit from the Crate

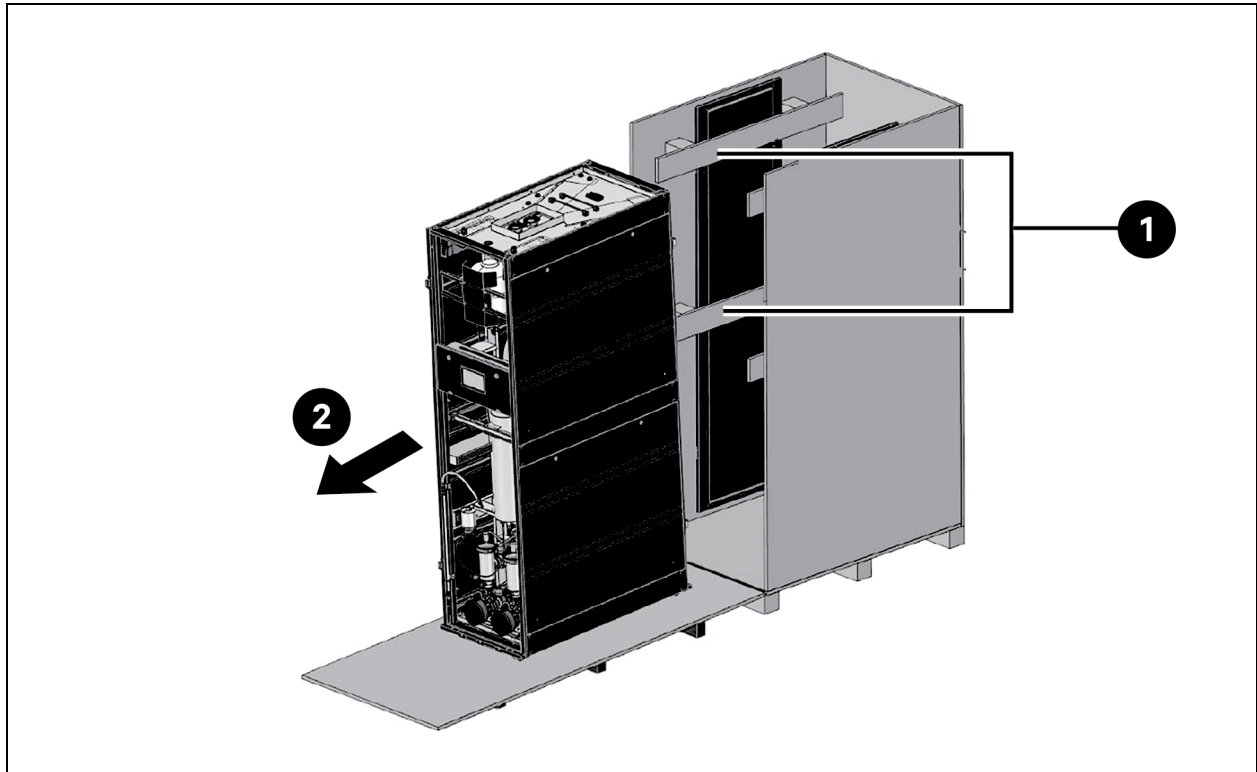

Item	Description
1	Unscrew and remove internal wooden braces on both sides to release Vertiv™ XDU070 bubble wrapped front and rear doors on one side and the roof panel on the other
2	Roll the XDU070 unit slowly and cautiously out of crate and down the ramp provided by the crate door, to ground level. Position the XDU070 away from crate ready for reassembly later

Remove the internal bracings shown in **Figure 5.2** above to access the front and rear doors for assembly.

After removing the unit from crate, see **Figure 5.3** on the facing page to assemble the unit.

Follow the below procedure to assemble the door of XDU070:

1. Position the unit at its final location and level it using the jacking feet.
2. Re-attach and bolt down the front and rear tie-down brackets to the floor if needed (optional).
3. Align the roof panel on top of the frame as shown, and secure it with the four M5 x 10 screws provided.
4. Align and position the front and rear doors with the door hinges. Attach each door using two hinge pins by inserting them into the door hinges.

NOTE: Front and rear doors are identical, so position is not defined.

Figure 5.3 Assembly of the Vertiv™ XDU070 Unit

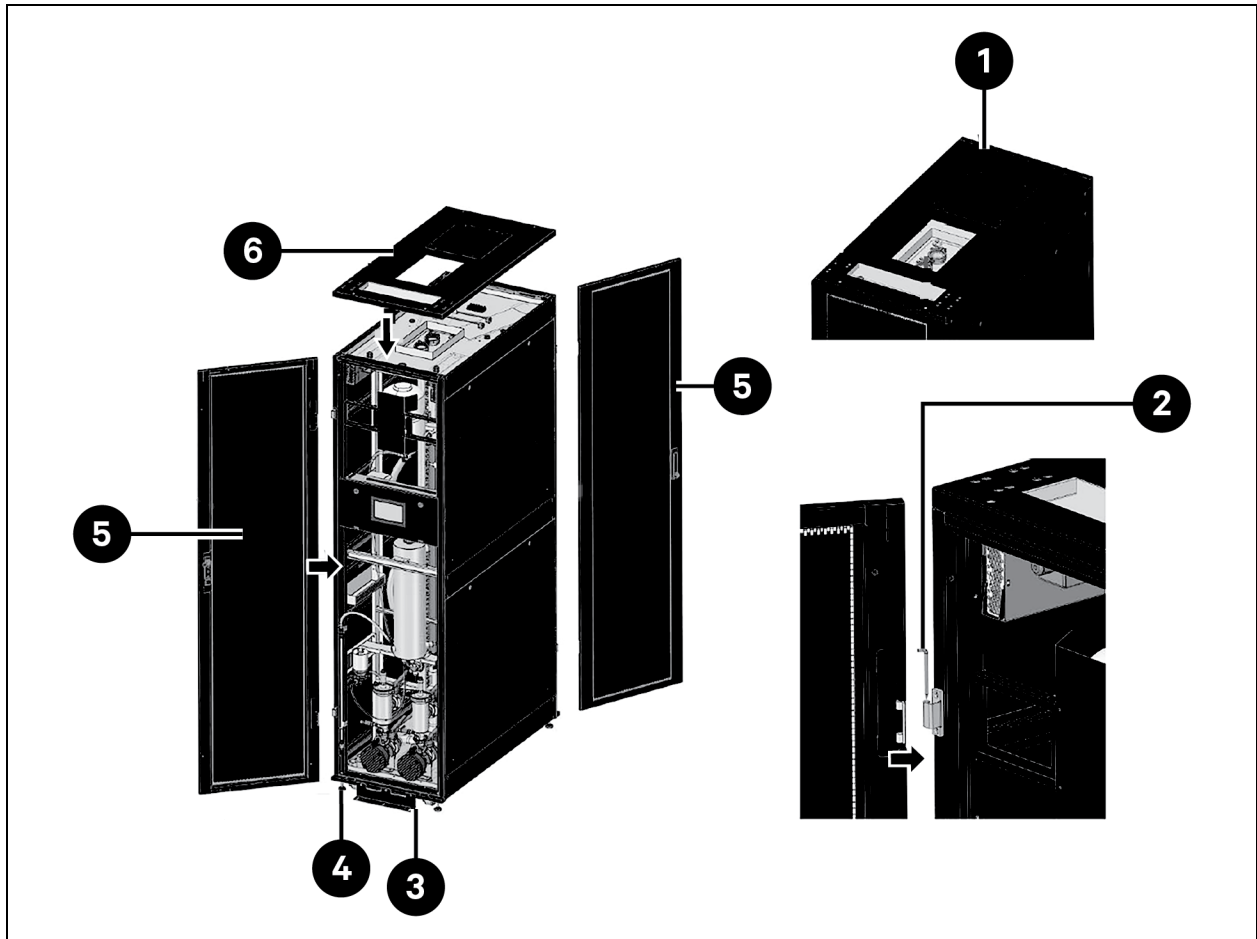

Item	Description
1	Roof panel fixing screw locations
2	Hinge pins
3	Front tie down brackets
4	Jacking feet
5	Front and rear door
6	Roof panel

5.2 Preparing the XDU070 for Operation

The XDU070 unit is shipped with a nitrogen gas holding charge in the fluid circuit to ensure the integrity of this circuit is not compromised during transit and remains free of contamination. This holding charge (set at 21.7 psi (1.5 bar) prior to shipping) should be released before any other work is carried out on the unit, as shown in **Figure 5.4** on the next page. Contact manufacturer if no gas can be heard escaping.



WARNING! This product is supplied with a 21.7 psi (1.5 bar) nitrogen holding charge in the fluid circuit, which will need to be vented during the installation process. Refer to **Fluid Circuit** on page 15 in this document for more information.

To release the nitrogen holding charge in three drain valve locations as shown in **Figure 5.4** below.

Figure 5.4 Release of Nitrogen Gas from Vertiv™ XDU070

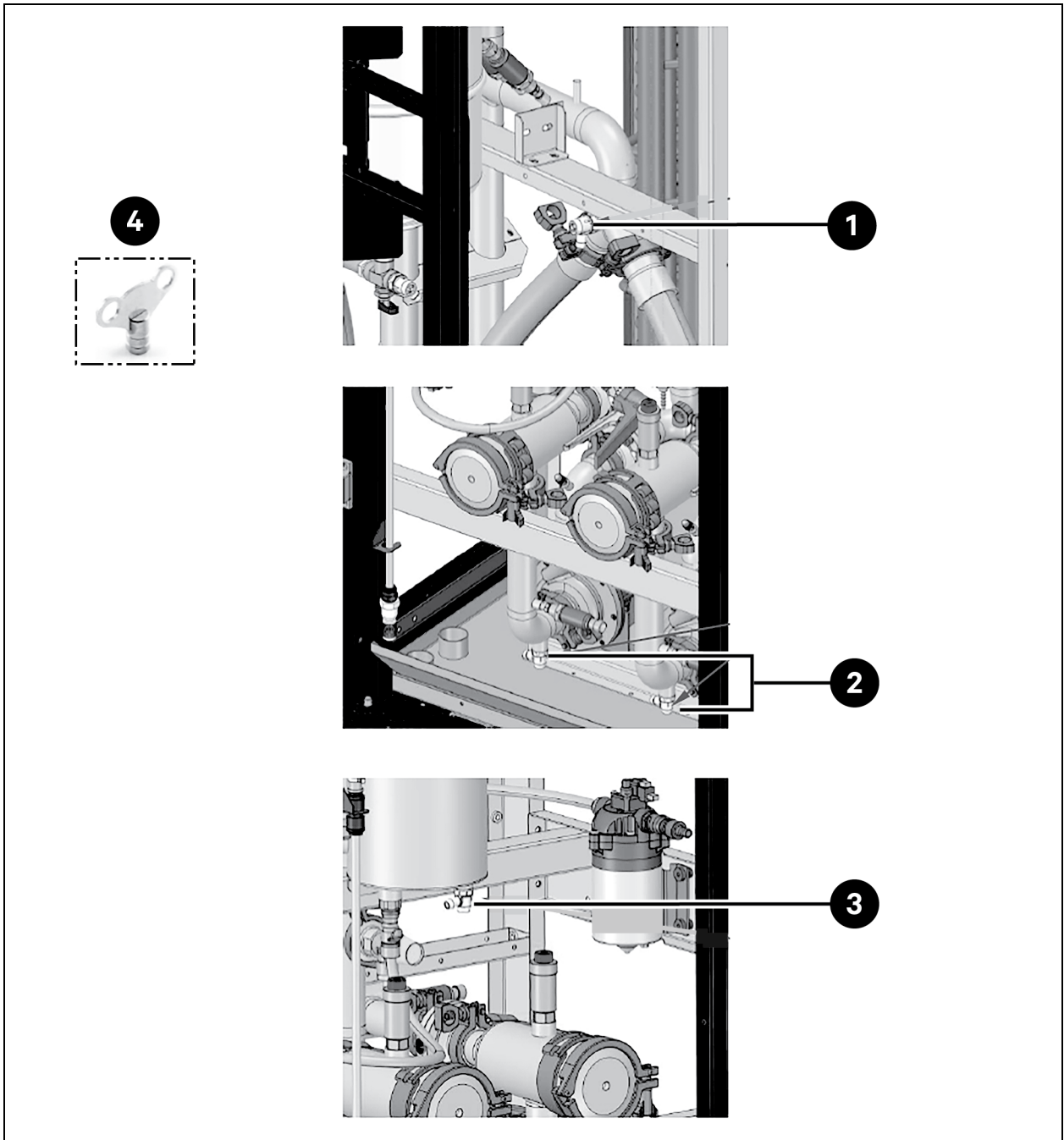

Item	Description
1	Vent nitrogen gas from return pipework, coils and pumps using drain valve on upper pipework Y piece.
2	Vent nitrogen gas from supply pipework and filters using either filter drain valve (it is not necessary to do both).
3	Vent nitrogen gas from reservoir tank using drain valve at the base of the tank.
4	Use the key provided to open/close all drain valves necessary for venting nitrogen gas.

NOTICE

Ensure all drain valves have been closed after venting nitrogen.

Figure 5.5 Preparing Vertiv™ XDU070 Unit for Operation

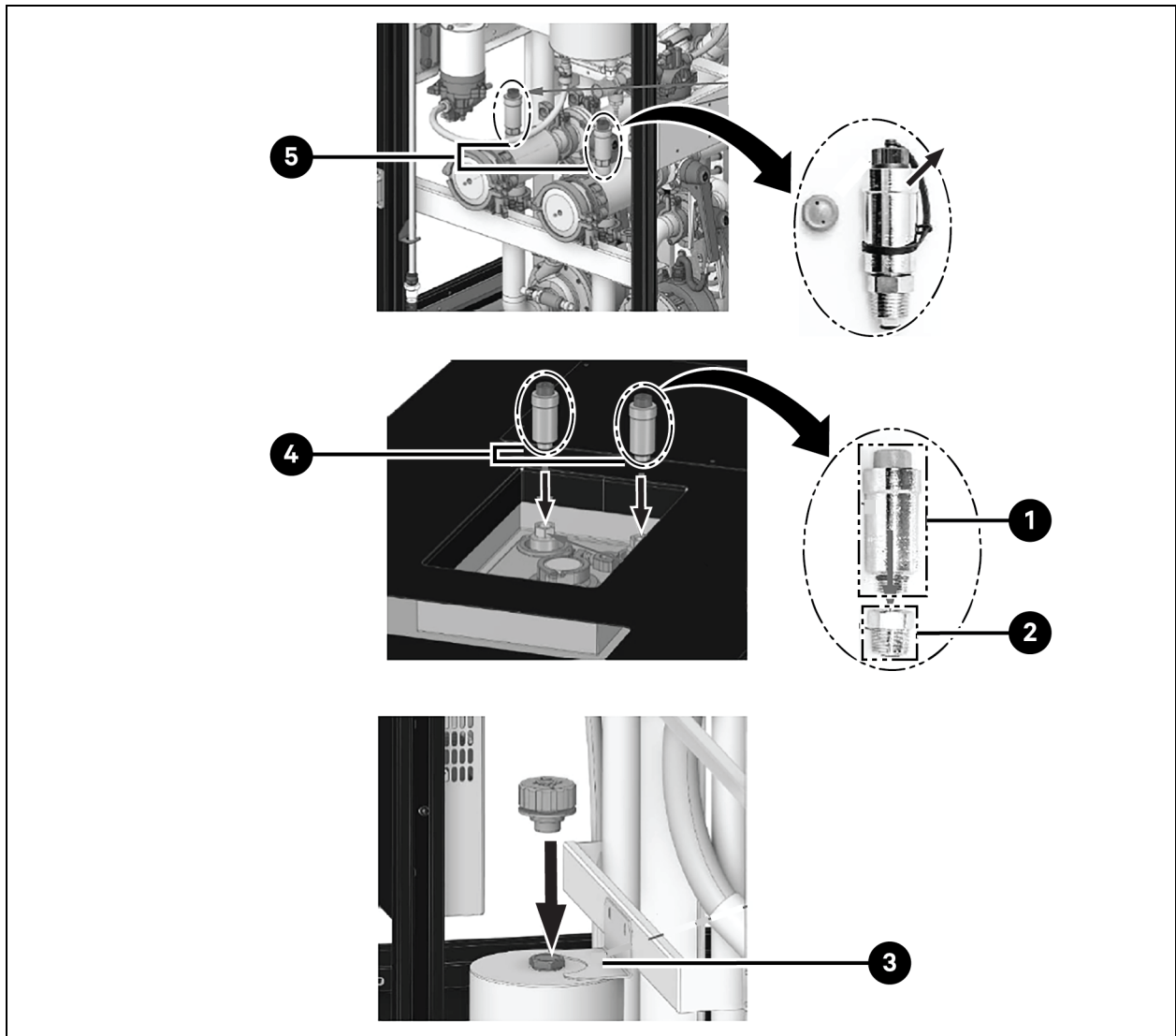

Item	Description
1	Auto air vent, supplied loose
2	Service valve, pre-fitted to coil header
3	Make sure that the nitrogen charge is removed. Remove the blanking cap and then install the breather cap.
4	Remove the dust caps from the air vent service valves and screw in auto air vents
5	Remove the black caps on filter auto air vents (fitted for nitrogen charge retention) and replace with the red ones supplied

5.3 Pipe Connections

The Vertiv™ XDU070 pipe connections are 1.5 in. (DN40) sanitary flanges (to BS4825 Pt.3) located on the top and bottom of the unit, see **Figure 5.6** on the facing page and **Figure 5.7** on page 28 for locations). The flanges are fitted with stainless steel blanking caps to ensure pipework remains contaminant free during transit and for retention of the nitrogen holding charge during transit, which will need to be removed during installation.

The bottom connection blanking caps are fitted with drain valves, which can be left in place if top exit pipe connections are to be made or removed and fitted to the top connections (to be used as air vents) if bottom exit pipe connections are to be made.

The flange seals supplied with the blanking caps can be reused when connecting site pipework, however it is recommended that seals are first inspected for any signs of damage.

External supply and return pipework are the responsibility of the end customer and care should be taken that all pipework is adequately supported.

Figure 5.6 Fluid Circuit Connections

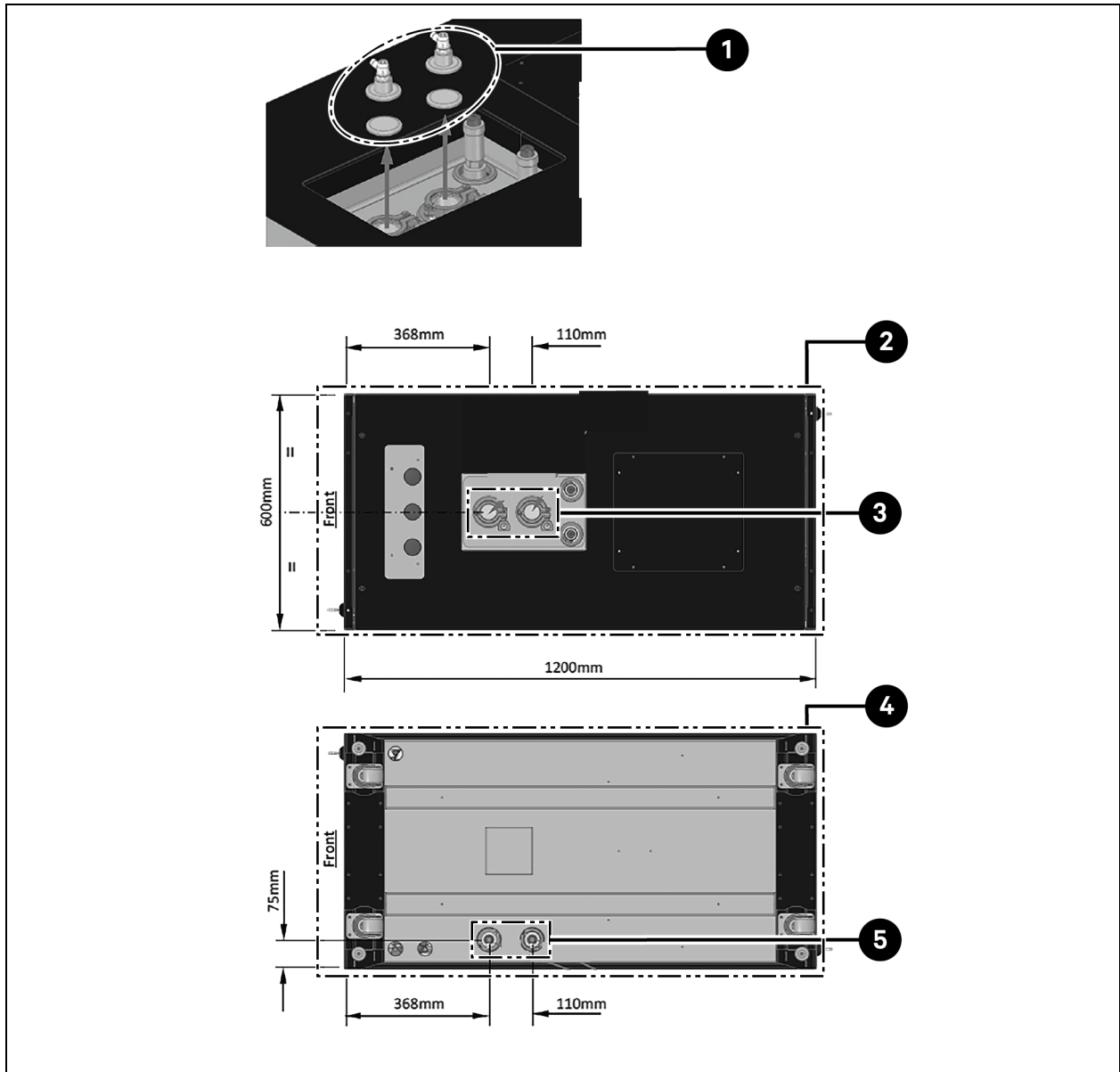

Item	Description
1	Remove blanking caps for top exit connections, or fit vents if bottom exit (only remove after nitrogen charge has been vented)
2	Plan view
3	1.5 in. (38.1 mm) sanitary flange top exit pipe connection
4	Underside view
5	1.5 in. (38.1 mm) sanitary flange bottom exit pipe connection

Figure 5.7 Fluid Circuit Connections (Side Elevation)

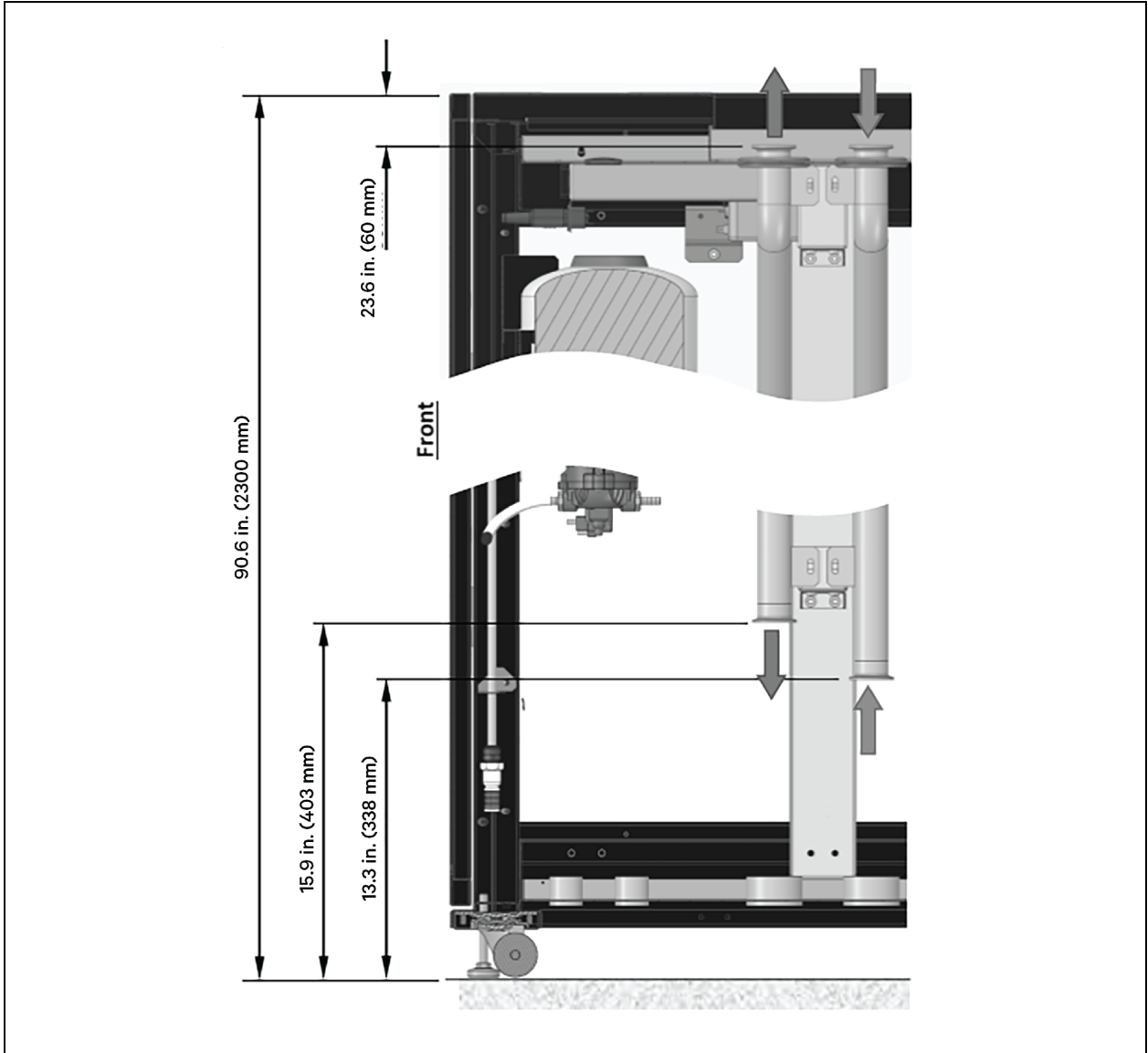

5.4 Electrical

5.4.1 Power Wiring



WARNING! This unit is powered by HIGH VOLTAGE. Serious injury or death can occur. All electrical work must only be carried out by a suitably qualified electrician. Installation should include a locally mounted isolator/switch disconnect to enable safe maintenance of the unit (to be supplied by others).



WARNING! Arc flash and electric shock hazard. Can cause serious injury or death. Building and equipment damage may also result. Disconnect all local and remote electric power supplies and wear appropriate, OSHA approved personal protective equipment (PPE) per NFPA 70E before working within the electric control enclosure. Customer must provide earth ground to unit, per NEC, CEC, and local codes, as applicable.

Verify with a voltmeter that power is off. The controller does not isolate power from the unit, even in the unit off mode. Some internal components still require and receive power even during the unit off mode of the controller. The factory supplied, optional disconnect switch is inside the unit. The line side of this switch contains live high voltage. The only way to ensure that there is NO voltage inside the unit is to install and open a remote disconnect switch. Refer to unit electrical schematic.

Before proceeding with installation, read all instructions, verify that all the parts are included and check the nameplate to be sure the voltage matches available utility power. Follow all local codes.



WARNING! Risk of electric shock. Can cause serious injury or death. Building and equipment damage may also result. Open all local and remote electric power supply disconnect switches and verify that power is off with a voltmeter before working within any electric connection enclosures. The controller does not isolate power from the unit, even in the unit off mode. Some internal components require and receive power even during the unit off mode of the controller.

Installation, service, and maintenance work must be performed only by properly trained and qualified personnel and in accordance with applicable regulations and manufacturer's specifications. Opening or removing the covers to any equipment may expose personnel to lethal voltages within the unit even when it is apparently not operating and the input wiring is disconnected from the electrical source.



WARNING! Risk of short circuits and electric shock. Can cause serious injury or death. Building and equipment damage can result from cut insulation or damaged wires. Can cause overheated wiring, smoke, fire, activation of fire suppression systems and EMS personnel, and loss of power to fans. Verify that all wiring connections are tight and that all wiring is contained within the junction box prior to closing and securing the cover.

Insert CSA certified or UL listed bushings into holes and/or knockouts used to route wiring through metal panels to protect the wire insulation from contact with sheet metal edges.



WARNING! Risk of improper wire sizing/rating and loose electrical connections causing overheated wire and electrical connection terminals resulting in smoke or fire. Can cause serious injury or death. Building and equipment damage may also result. Use correctly sized copper wire only and verify that all electrical connections are tight before turning power on. Check all electrical connections periodically and tighten as necessary.



WARNING! Risk of improper wiring, piping, moving, lifting, and handling. Can cause serious injury or death. Building and equipment damage may also result. Installation and service of this equipment should be done only by qualified personnel who have been specially trained in the installation of air conditioning equipment and who are wearing appropriate, OSHA approved PPE.

NOTICE

Risk of improper power supply connection. Can cause equipment damage and loss of warranty coverage.

Prior to connecting any equipment to a main or alternate power source (for example backup generator systems) for startup, commissioning, testing, or normal operation, ensure that these sources are correctly adjusted to the nameplate voltage and frequency of all equipment to be connected. In general, power source voltages should be stabilized and regulated to within $\pm 5\%$ of the load nameplate nominal voltage. Also, ensure that no three phase sources are single phased at any time.

See transformer label for primary tap connections. Installer will need to change transformer primary taps if applied unit voltage is other than prewired tap voltage.

NOTICE

Risk of improper electrical connection of three phase input power. Can cause backward pump rotation and unit damage. Service technicians should use a gauge set on the system during the initial start up to verify that the three phase power is connected properly. Three phase power must be connected to the unit line voltage terminals in the proper sequence so that the pump rotates in the proper direction. Incoming power must be properly phased to prevent pump from running backward. We recommend checking the unit's phasing with proper instrumentation to ensure that the power connections were made correctly. We also recommend verifying discharge and suction pressures during startup to ensure that the pumps are running in the correct direction.

The incoming A and B power cables can be routed into the unit via the roof panel or through the base of the cabinet. The roof panel is provided with crosscut blind grommets for top cable entry and transition tubes are provided through the drip tray in the base of the unit for bottom cable entry. Bottom entry cables may be secured up the internal channels of the rack frame.

Figure 5.8 Power Cable Top/Bottom Entry and Connections (Power Supply A Connection Only Shown)

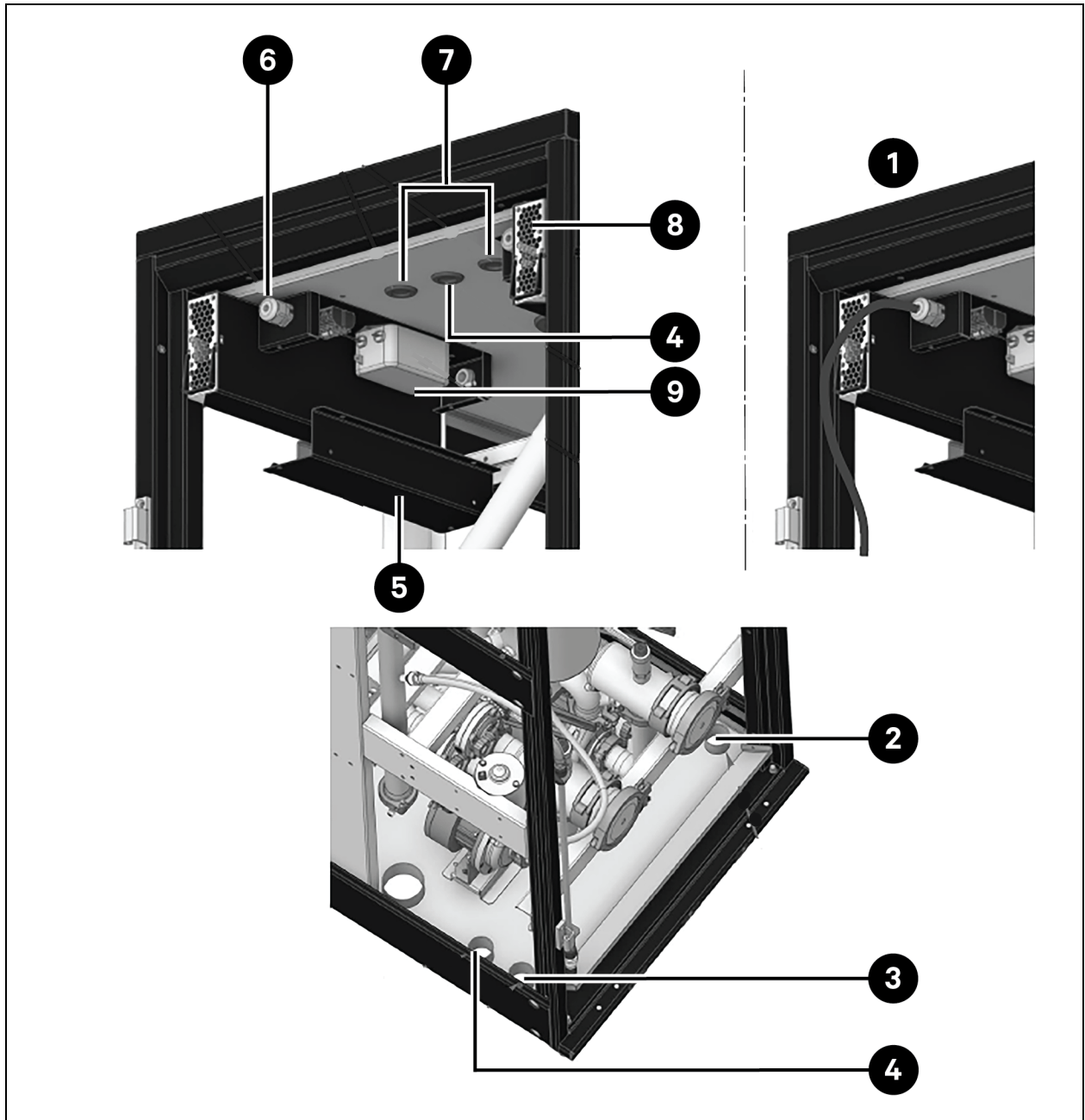

Item	Description
1	Bottom entry cable route
2	Power cable B entry point
3	Power cable A entry point
4	Entry point for comms cable

Item	Description
5	Removable cover
6	Cable gland A entry to terminate block
7	Blind grommets in roof panel for A and B power cable entry
8	Cable gland B entry to terminal block
9	RFI Filter

5.4.2 EMC Wiring

RF Earth Connection—For EMC compliance, two M6 earth studs are provided at the rear of the cabinet (one at the top and one at the bottom) for connection of a braided EMC earth strap at either point.

5.5 Communications

5.5.1 Ethernet Connections

Two Ethernet redundant communication ports (RJ45) are provided on the back of the unit control panel, labeled ETHA and ETHB. Cat5e shielded cable should be used when wiring to these ports.

Figure 5.9 Ethernet Communications

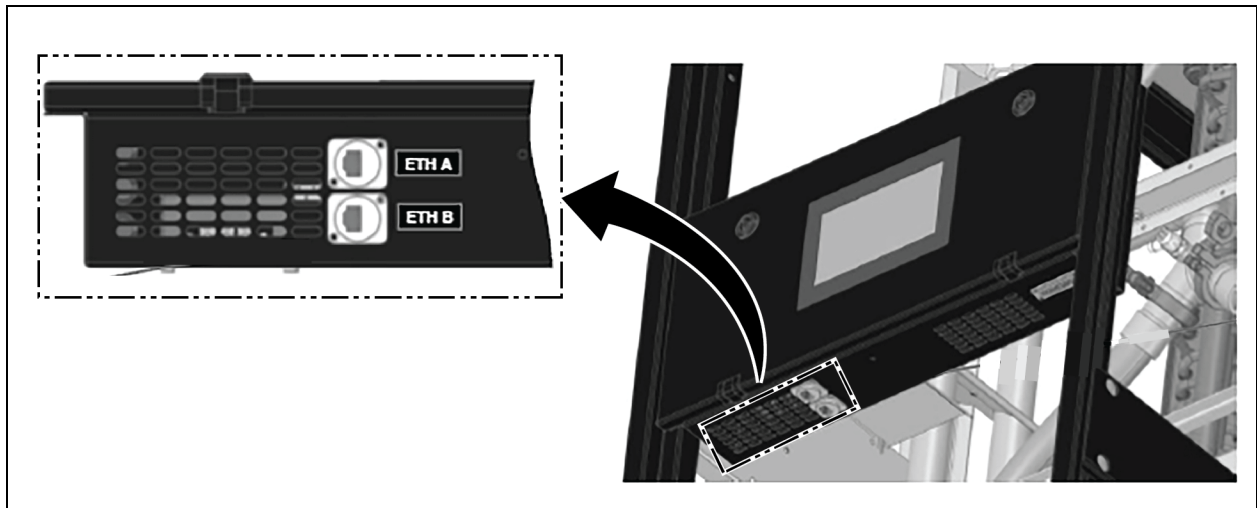

5.6 Pre-Commissioning Checks

5.6.1 Site Check

1. Check if the site requires protective equipment such as safety boots.
2. Check that PG-25 fluid has been delivered to site.
3. Ensure that the site contact is aware of the location of the Vertiv™ XDU070 power supplies A and B.

5.6.2 Mechanical Installation Check

1. Confirm that the Vertiv™ XDU070 has been successfully unloaded from its crate and thoroughly inspected for damage, paying particular attention to external cabinet panels and water circuit pipe work.
2. Verify that the XDU070 has been positioned and secured in the correct location.
3. If the unit has bottom power and communications cable entry, confirm that floor tiles have been cut away as required, ideally fitted with brush strip grommets to allow cables to run neatly from the under floor void.
4. Check that cable baskets, cable trays, drip trays, etc. have been installed to provide adequate support for the hoses routed above the unit.
5. Confirm sufficient space has been allowed at the front and rear of the unit to fully open the access doors.
6. Ensure the unit has been raised and leveled with the jacking feet into its final permanent position and tie down brackets have been secured to the floor front and back (if required).

5.6.3 Electrical Installation Check



WARNING! Arc flash and electric shock hazard. Open all local and remote electric power supply disconnect switches, verify with a voltmeter that power is off and wear appropriate, OSHA approved personal protective equipment (PPE) per NFPA 70E before working within the electric control enclosure. Failure to comply can cause serious injury or death. Customer must provide earth ground to unit, per NEC, CEC and local codes, as applicable. Before proceeding with installation, read all instructions, verify that all the parts are included and check the nameplate to be sure the voltage matches available utility power. The controller does not isolate power from the unit, even in the unit off mode. Some internal components require and receive power even during the unit off mode of the controller. The only way to ensure that there is NO voltage inside the unit is to install and open a remote disconnect switch. Refer to unit electrical schematic. Follow all local codes.

Installation, service, and maintenance work must be performed only by properly trained and qualified personnel and in accordance with applicable regulations and manufacturer's specifications. Opening or removing the covers to any equipment may expose personnel to lethal voltages within the unit even when it is apparently not operating and the input wiring is disconnected from the electrical source.



WARNING! Risk of electric shock. Can cause equipment damage, injury or death. Open all local and remote electric power supply disconnect switches and verify with a voltmeter that power is off before working within any electric connection enclosures. Service and maintenance work must be performed only by properly trained and qualified personnel and in accordance with applicable regulations and manufacturer's specifications. Opening or removing the covers to any equipment may expose personnel to lethal voltages within the unit even when it is apparently not operating and the input wiring is disconnected from the electrical source.



WARNING! This unit is powered by HIGH VOLTAGE. Serious injury or death can occur. All electrical work must only be carried out by a suitably qualified electrician.

1. Check that the voltage available at the connection points to the Vertiv™ XDU070 unit meet the power requirements for both supply A and B.
2. Ensure power cables are adequately supported and clipped into position.
3. Confirm that all electrical connections are tight.

4. Confirm any required external peripheral alarms/sensors are correctly fitted.

5.6.4 Secondary Fluid Specification

The fluid used in the secondary circuit should be water or PG 25 coolant with inhibitors heat transfer fluid for the cooling application. If you have questions regarding which coolant to use, contact Vertiv Support.

Failure to use proper water treatment can result in decreased system performance and reliability due to corrosion, scaling, fouling and microbiological growth.

Suitable secondary circuit heat transfer fluid can be provided by the CDU supplier on request.

6 Commissioning

6.1 Unit Configuration

Prior to running the Vertiv™ XDU070, check the controller configuration to ensure the unit is set up according to the site requirements. Most settings are pre-configured however, some may need to be adjusted as below. Turn power ON to the unit in order to make adjustments.

- **Set Date and Time**—Go to Setup screen > Date. Adjust the date as required, followed by the date format using Date Format (P021), if required. Go to Setup screen > Time to set the time to the current local time. Daylight Saving (P022) and Network Time Protocol (P023 and P024) which can also be set if required. Setting the Date and Time is important as it helps in future the analyzing log files.
- **Communications**—See Setup menu for group control CANbus communication. Refer to the Communications section in the *XDU070 Coolant Distribution Unit Application and Planning Guide SL-71111*.

6.1.1 Fluid Circuit

6.1.2 Pipework Connections

1. Check the external manifold pipework has been correctly flushed (especially if any hot works have been carried out).
2. Verify that newly fitted external pipework and connections, including any hoses have been tested for leaks using an appropriate pressure testing method and ensure certification can be provided.
3. Check that all external pipes have been correctly and neatly routed from the XDU070 to the system.
4. Confirm that external pipework has been adequately supported and all fixings are tight.

6.1.3 Circuit Filling

NOTICE

When filling and running the fluid circuit, the operator should be fully conversant with the operation of the XDU070. Refer to *XDU070 Coolant Distribution Unit Operating and Maintenance Guide SL-71112* for more information.

1. Position the container of cooling fluid in front of the XDU070.
2. Ensure the automatic air vents located on each filter housing and the coil headers are fitted with red plastic caps, finger tight (not temporary black caps fitted for transit nitrogen charge).
3. Ensure all drain valves are closed.
4. Ensure that any external valves between the XDU070 and the system are open.
5. Remove the term is fill wand and insert into the container of cooling, then connect the filling wand hose to the fill pump P4 quick release coupling. See **Figure 6.1** on the next page for storage location

Figure 6.1 Fill Pump Operation

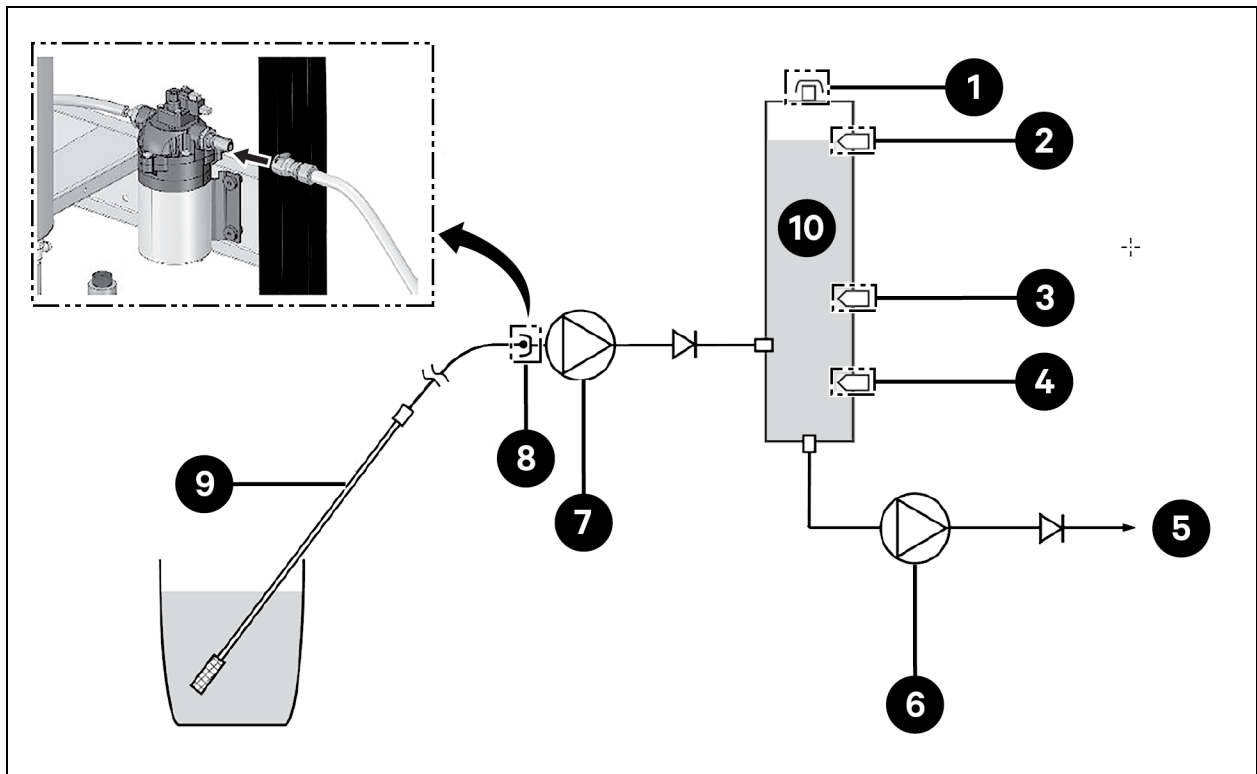

Item	Description
1	Breather
2	High level (full)—Fill pump P4 disabled when wet and enabled when dry
3	Low level (water required)—Alarm A14 (reservoir tank fluid required)
4	Very low level (empty)—Alarm A15 reservoir tank empty and fill pump P3 disabled
5	Vertiv™ XDU070 circuit
6	Fill pump P3 (automatic start/stop to maintain system pressure setpoint)
7	Fill pump P4 (manual start/stop and automatic stop when reservoir tank full)
8	Self sealing quick connect
9	Filling wand connected to fill pump P4 when reservoir tank needs to be replenished
10	2.6 gal. (10 liters) reservoir tank

NOTE: Fill pumps P3 and P4 interlocked to prevent both running at the same time.

- Log on to the controller with the service access code—5669. Go to the Service screen and select Fill Pump Control.
- Select Fill Pump P4 followed by ON. The fill pump will then start pumping the cooling fluid into the unit reservoir tank at the rate of approx. 1.1 gpm (4 l/m.).

8. The reservoir level sensors can be monitored during the filling process while in the Fill Pump Control screen. The sensor condition will change from white to green as fluid reaches each sensor level. Reservoir capacity is 2.6 gals. (10 liters).
9. Ensure the fluid container with the filling wand does not run dry during this process. Fill pump P4 will switch OFF automatically when the reservoir tank is full or can be manually switched OFF at any time using the OFF command shown in **Figure 6.2** below.

NOTICE

Fill pumps P3 and P4 are interlocked, so they cannot run at the same time, that is when pump P4 is running P3 displays as Disabled and when pump P3 is running P4 displays as Disabled.

Figure 6.2 Fill Pump Control Screen (for Fill Pumps P4 and P3)

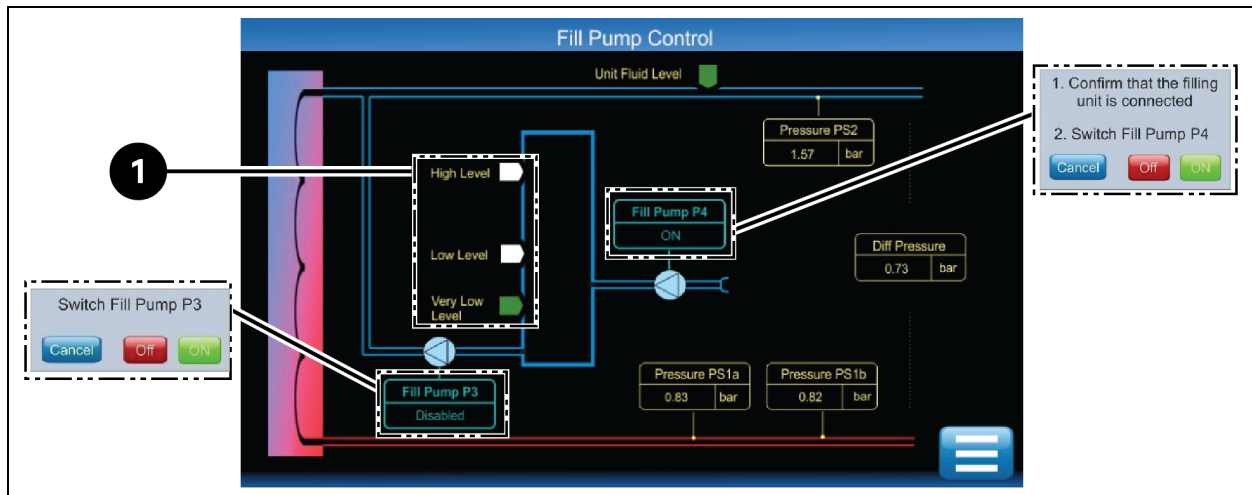

Item	Description
1	Level indicators change from white to green when wet

10. After reservoir tank is full, it can be emptied into the Vertiv™ XDU070 system using fill pump P3. Select fill Pump P3 followed by ON.

NOTICE

While the system is filling, open the vent on the expansion vessel valve as shown in [Expansion Vessel Venting](#) on the next page.

11. Fill pump P3 will switch OFF automatically when the reservoir tank reaches the very low level sensor or can be manually switched OFF at any time using the OFF command.
12. Repeat the process of filling the reservoir tank with pump P4 then pumping reservoir contents into the system with pump P3 until fill pump P3 stops automatically when system static fill pressure is greater than or equal to 14.5 psi (1.0 bar). The system pressure (PS1a and PS1b) can be monitored on the Fill Pump Control screen shown in **Figure 6.2** above, or on the Home screen.
13. Once the system is at the required static fill pressure, go back to fill pump P4 and ensure that the reservoir tank is fully topped up.
14. Leave the filling wand connected and in the container as more fluid will be required as air is expelled from the system during the initial operation.

6.1.4 Expansion Vessel Venting

1. While the system is filling, the hose leading to the expansion vessel should be manually vented. Set the handle on the 3-way valve located on the underside of the expansion vessel to the middle position as shown in **Figure 6.3** below.

Figure 6.3 Valve Handle

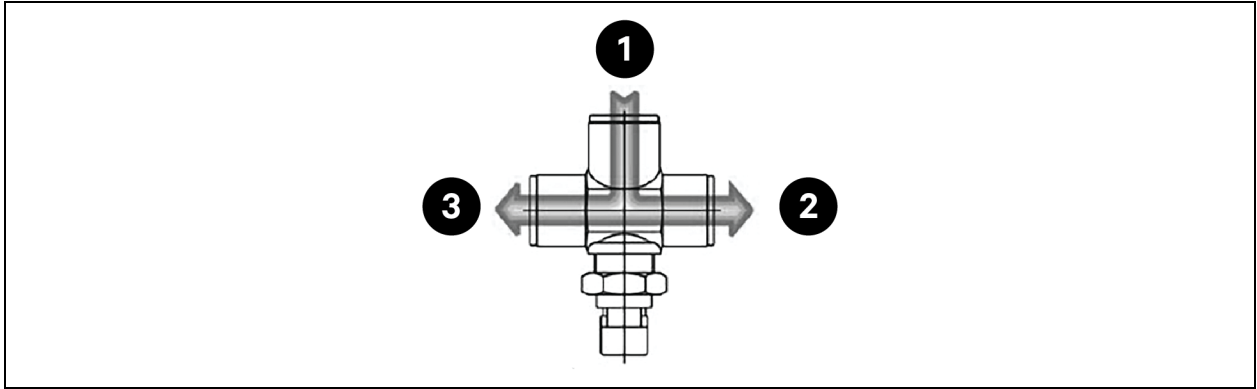

Item	Description
1	Expansion vessel
2	Drain valve
3	System

Commissioning position—Valve handle set to connect expansion vessel to both system and drain valve, allowing trapped air in system to be vented out through drain valve during the filling process.

2. Crack open the drain valve (using the key provided) to allow trapped air to vent. Close the drain valve as soon as fluid starts to emerge (the hose provided may be used to avoid fluid spillage in the unit).
3. Once the drain valve is closed, set the valve handle as shown in **Figure 6.3** above for normal system operation.

Figure 6.4 Valve Handle Set in Normal Operating Position

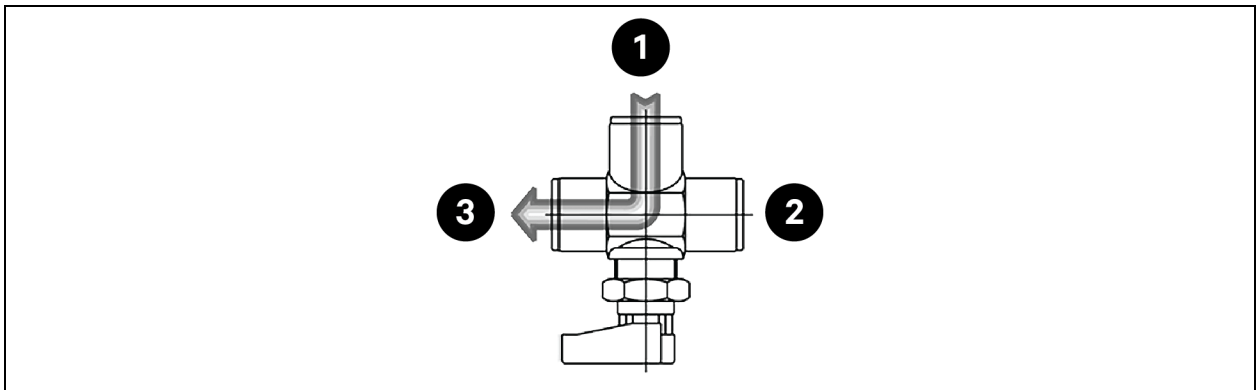

Item	Description
1	Expansion vessel
2	Drain valve
3	System

Normal operating position—Valve handle set to connect expansion vessel to system pressure.

6.2 Fluid Circulation

6.2.1 Low Speed Circulation

After the initial fill process, the fluid should be circulated at a low flow rate initially to enable trapped air in the system to vent via the automatic air vents.

Set the unit up for Flow Control by going to the Configuration screen / Pump Control / Control Type (P201), select flow (see **Vertiv™ XDU070 Coolant Distribution Unit Operating and Maintenance Guide SL-71112** for more information). Start the unit by pressing the green start icon on the Home screen of the display. Pump P1 will start and ramp up to deliver a reduced default flow rate of 6.6 gpm (25 l/m). During this operation, the fans at the rear of the unit will also be running at a minimum 15% fan speed.

The unit should run for approximately 30 minutes at this reduced pump speed to gently circulate the fluid.

NOTICE

The minimum pump speed is 15%, and the default flow may not be achieved if it requires the pump to operate below this speed depending on system impedance.

Once the period of reduced flow circulation has been completed, it is recommended that each pump is ramped up to full speed for a few minutes to check maximum flow operation, which can be carried out by using the overrides function.

To adjust the pump speed with the Overrides function:

Go to the Logon screen and enter the service access code, then go to the Service menu and select Overrides. Select Pump P1 (S101) and set to 100% speed operation, followed by the OK button.

NOTICE



The display will show the following icon  on the Home screen while the override function is active. If there is no touchscreen interaction for 15 minutes (default) or more, the controller will revert to full automatic mode.

Check the unit and the system for leaks. Check the pump for any abnormal noise.

NOTICE

When the pump is running at increased speed, the fill pressure at PS1 may drop and the fill pump P3 may automatically re-activate again.

Set pump P1 speed back to 0% and repeat for operation pump P2 by selecting pump P2 (S102) and set to 100% speed operation, followed by the OK button.

Check pump for any abnormal noise.

NOTICE

Pumps P1 and P2 are interlocked, so it is not possible to run both pumps together in overrides.

Once operation of both pumps has been deemed satisfactory, the override setting may be set back to 0% for automatic control.

Stop the unit using the Start/Stop icon on the Home screen.

6.2.2 Normal Circulation

The unit should now be set back to DP control by going to the Configuration screen > Pump control > Control type (P201) and selecting DP.

Start the unit again and check that the operational pump ramps up to the pre-set DP setpoint 12.3 psi (0.85 bar) default.

Check that the flow delivered at this DP is the required 18.5 gpm (70 l/m) \pm 0.79 gpm (3 l/m). If not, then go to the Configuration screen > Differential Setpoint (P203) and adjust the DP setpoint up or down until the correct flow rate is achieved.

6.3 Fan Operation

During the fluid flow checks carried out in see section [Fluid Circulation](#) on the previous page and while there is no thermal load on the unit, the fans will be running at a minimum 15% of full fan speed.

It is recommended that the fans are checked for full speed operation by using the Overrides function as before.

To adjust the fan speed with the Overrides function:

1. Go to the Service menu and select Overrides. Select the fan speed (S105) and enter a speed of 50%, followed by the OK button.
2. Allow fans to ramp up to speed and check that all fans are running with no abnormal noise.
3. Adjust speed to 100% and check again that all fans are running with no abnormal noise.
4. Set override fan speed back to 0% for automatic control.

6.4 Subsequent Filling

Once the unit is commissioned, check that the reservoir tank is full before disconnecting the filling wand and placing it back in its storage location. If the reservoir tank is not full, repeat the filling process see in section [Circuit Filling](#) on page 35.

During normal operation, if the system requires topping up with fluid, then this will happen automatically with fill pump P3 taking fluid from the 2.6 gal. (10 liters) reservoir tank. When level drops in the reservoir there is a two stage A14 - reservoir tank fluid required and A15 - reservoir tank empty alarm process.

Appendices

Appendix A: Technical Support and Contacts

A.1 Technical Support/Service in the United States

Vertiv Group Corporation

24x7 dispatch of technicians for all products.

1-800-543-2378

Thermal Management Products

1-800-543-2378

Channel Products

1-800-222-5877

AC and DC Power Products

1-800-543-2378

A.2 Locations

United States

Vertiv Headquarters

505 N. Cleveland Ave.

Westerville, OH 43082, USA

Europe

Via Leonardo Da Vinci 8 Zona Industriale Tognana

35028 Piove Di Sacco (PD) Italy

Asia

7/F, Dah Sing Financial Centre

3108 Gloucester Road

Wanchai, Hong Kong

This page intentionally left blank

Appendix B: Piping Schematic

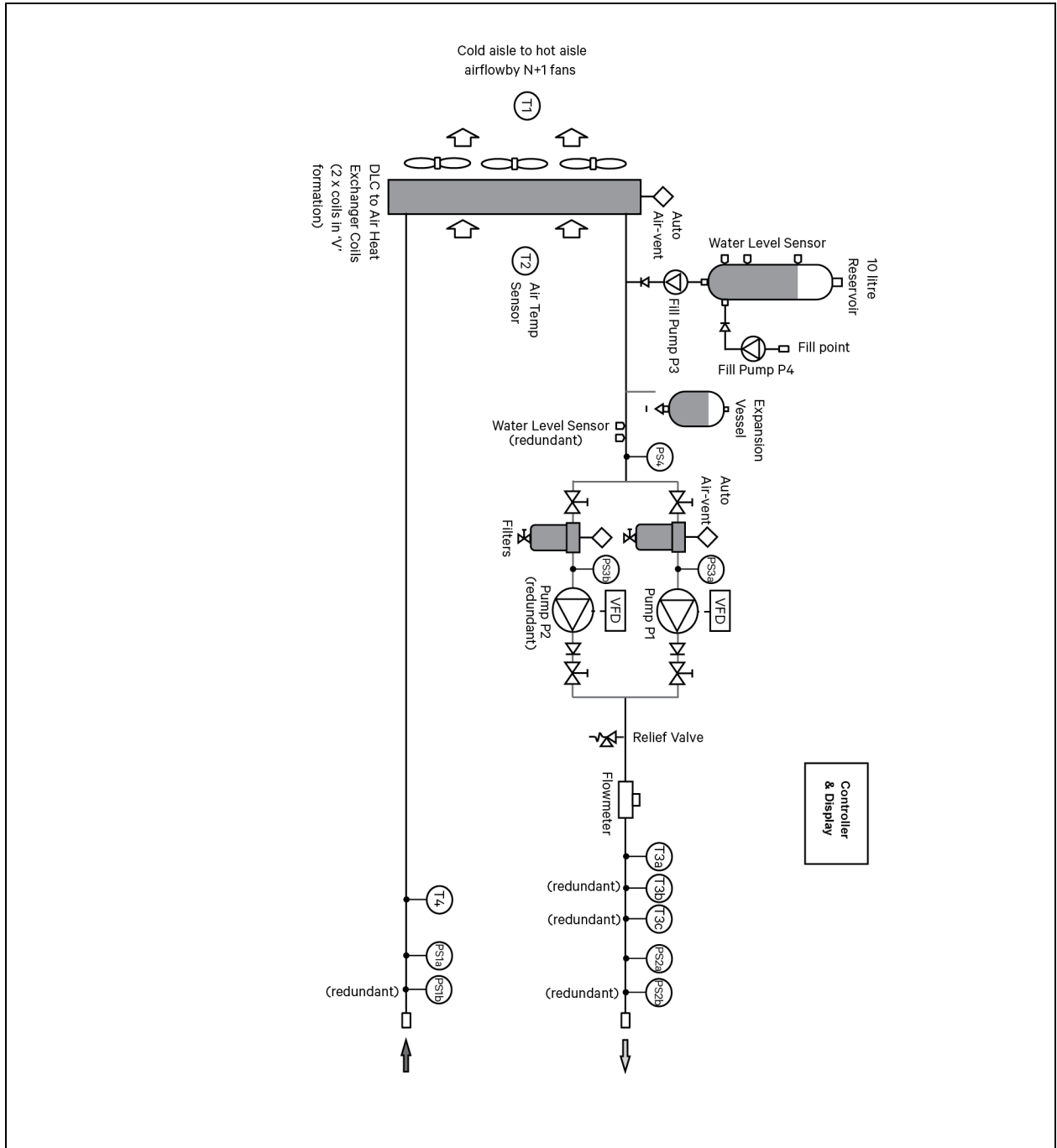

This page intentionally left blank

Appendix C: Warranty Details

C.1 Limited Product and Service Warranty

Extended warranties, service and maintenance programs are available in most locations, details available upon request. To obtain further details of limited warranty, also after sales service offerings, contact your local sales representative or technical support if you have any questions or problems during unit installation.

This page intentionally left blank

This page intentionally left blank

Appendix E: Disposal Information

NOTE: Waste materials must be disposed of in a responsible manner in line with environmental regulations.

The de-commissioning and disposal of this product should be undertaken by qualified personnel in adherence to local and national safety regulations, particularly for protection of lungs, eyes and skin from chemicals, dust, etc. Approved lifting gear and power tools should be used and access to the work area must be restricted to authorized personnel.

The following steps are a guide only and should be adjusted to take into account local site conditions:

1. Disconnect unit from electrical supply.
2. Drain and dispose of any heat transfer fluid through an approved recycling facility.
3. Remove unit to approved recycling facilities only.

This page intentionally left blank

Connect with Vertiv on Social Media



<https://www.facebook.com/vertiv/>



<https://www.instagram.com/vertiv/>



<https://www.linkedin.com/company/vertiv/>



<https://www.twitter.com/Vertiv/>



Vertiv.com | Vertiv Headquarters, 505 N. Cleveland Ave., Westerville, OH 43082, USA

© 2024 Vertiv Group Corp. All rights reserved. Vertiv™ and the Vertiv logo are trademarks or registered trademarks of Vertiv Group Corp. All other names and logos referred to are trade names, trademarks or registered trademarks of their respective owners. While every precaution has been taken to ensure accuracy and completeness here, Vertiv Group Corp. assumes no responsibility, and disclaims all liability, for damages resulting from use of this information or for any errors or omissions.

SL-71110_REVC_09-24