



NetSure™ -48 VDC Distribution Unit

Installation and User Manual

Specification Number: 562579

The information contained in this document is subject to change without notice and may not be suitable for all applications. While every precaution has been taken to ensure the accuracy and completeness of this document, Vertiv assumes no responsibility and disclaims all liability for damages resulting from use of this information or for any errors or omissions. Refer to other local practices or building codes as applicable for the correct methods, tools, and materials to be used in performing procedures not specifically described in this document.

The products covered by this instruction manual are manufactured and/or sold by Vertiv. This document is the property of Vertiv and contains confidential and proprietary information owned by Vertiv. Any copying, use or disclosure of it without the written permission of Vertiv is strictly prohibited.

Names of companies and products are trademarks or registered trademarks of the respective companies. Any questions regarding usage of trademark names should be directed to the original manufacturer.

Technical Support Site

If you encounter any installation or operational issues with your product, check the pertinent section of this manual to see if the issue can be resolved by following outlined procedures.

Visit <https://www.vertiv.com/en-us/support/> for additional assistance.

TABLE OF CONTENTS

Admonishments Used in this Document	iv
Important Safety Instructions	v
Safety Admonishments Definitions.....	v
Safety and Regulatory Statements.....	v
Déclarations de Sécurité et de Réglementation.....	v
1 Description	1
2 Specifications	1
2.1 Electrical.....	1
2.2 Environmental.....	2
2.3 Compliance Information.....	2
2.4 Dimensions and Weight.....	2
3 Accessories	3
3.1 23" Mounting Bracket Adapter Plates, P/N 563148.....	3
3.2 Bullet Nose Type Load Distribution Circuit Breakers.....	3
3.3 Bullet Nose Bypass Busbar with Handle, P/N 563020.....	3
3.4 GMT Load Distribution Fuses.....	3
3.5 Lugs.....	5
4 Installing the Distribution Unit	6
4.1 General.....	6
4.2 Securing the Distribution Unit to a Relay Rack or a Cabinet Equipment Rack (if required).....	6
4.3 Installing Circuit Breakers and Fuses.....	8
5 Making Electrical Connections	10
5.1 Important Safety Instructions.....	10
5.2 Wiring Considerations.....	10
5.3 Relay Rack / Cabinet Frame Grounding Connection.....	10
5.4 Distribution Unit Frame Grounding Connection.....	10
5.5 External Circuit Breaker / Fuse Alarm Connections.....	11
5.6 Load Distribution Wiring to GMT Fuse Blocks.....	13
5.7 Load Distribution Wiring to Distribution Circuit Breakers.....	13
5.8 Input Wiring.....	17
6 Initial Startup	17
7 Troubleshooting and Repair	17
7.1 Contact Information.....	17
7.2 Replacement Procedures.....	18
7.2.1 Replacing a Distribution Device.....	18

Admonishments Used in this Document



DANGER! Warns of a hazard the reader *will* be exposed to that will *likely* result in death or serious injury if not avoided. (ANSI, OSHA)



WARNING! Warns of a potential hazard the reader *may* be exposed to that *could* result in death or serious injury if not avoided. This admonition is not used for situations that pose a risk only to equipment, software, data, or service. (ANSI)



CAUTION! Warns of a potential hazard the reader *may* be exposed to that *could* result in minor or moderate injury if not avoided. (ANSI, OSHA) This admonition is not used for situations that pose a risk only to equipment, data, or service, even if such use appears to be permitted in some of the applicable standards. (OSHA)



ALERT! Alerts the reader to an action that *must be avoided* in order to protect equipment, software, data, or service. (ISO)



ALERT! Alerts the reader to an action that *must be performed* in order to prevent equipment damage, software corruption, data loss, or service interruption. (ISO)



FIRE SAFETY! Informs the reader of fire safety information, reminders, precautions, or policies, or of the locations of fire-fighting and fire-safety equipment. (ISO)



SAFETY! Informs the reader of general safety information, reminders, precautions, or policies not related to a particular source of hazard or to fire safety. (ISO, ANSI, OSHA)

Important Safety Instructions

Safety Admonishments Definitions

Definitions of the safety admonishments used in this document are listed under “Admonishments Used in this Document” on page iv.

Safety and Regulatory Statements

Refer to Section 4154 (provided with your customer documentation) for Safety and Regulatory Statements.

Déclarations de Sécurité et de Réglementation

Reportez-vous à la Section 4154 (fourni avec les documents de votre client) pour les déclarations de sécurité et de réglementation.

This page intentionally left blank.

1 Description

A 1RU high by 19" wide distribution unit with (12) GMT fuse load positions and (4) bullet nose-type circuit breaker load positions.

Provides...

- (12) GMT fuse load distribution positions (0 A to 15 A).
- (4) bullet nose-type circuit breaker load distribution positions (1 A to 150 A).
- Three (3) input connection points.
- CBA/FA alarm relay contacts and resistive battery for connection to external alarms.

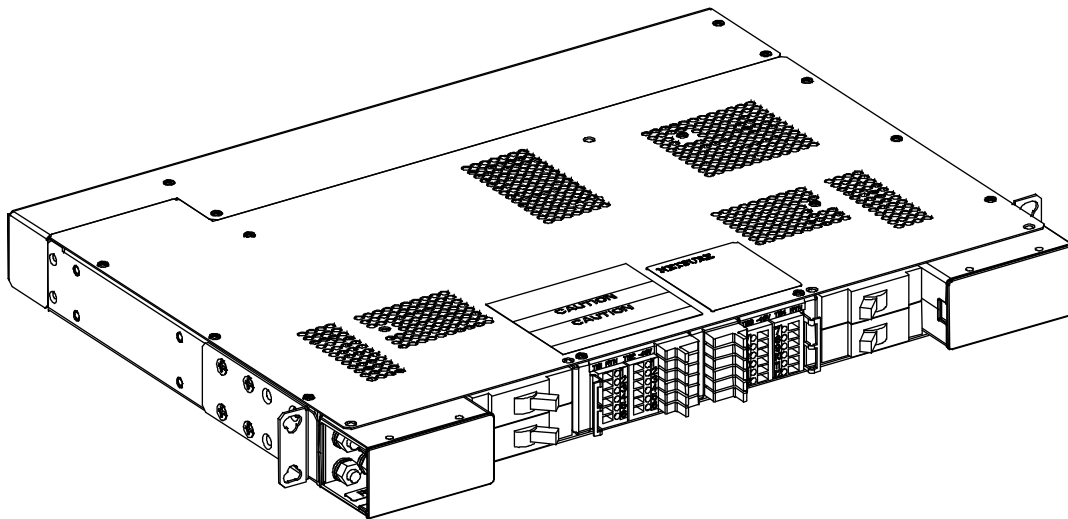

2 Specifications

2.1 Electrical

1. Input / Output Voltage: Nominal -48 VDC.
2. Maximum Input Current: 150 A.
3. Maximum Load Distribution Current: 150 A @ +40 °C (+104 °F) and 80 A @ +65 °C (+149 °F).
4. Maximum GMT Fuse Block Capacity: 35 A @ +40 °C (+104 °F) and 30 A @ +65 °C (+149 °F).
5. Maximum GMT Fuse Size: 15 A.
6. Maximum Load Distribution Circuit Breaker Size: 150 A @ +40 °C (+104 °F) or +65 °C (+149 °F).
7. Circuit Breaker / Fuse Alarm Circuit: A set of Form-C alarm relay contacts and resistive battery are provided for connection to external CBA/FA alarms. Relay contacts rated for 2 A @ 30 VDC, 0.6 A @ 110 VDC, and 0.6A @ 125 VAC.

2.2 Environmental

1. Operating Ambient Temperature Range: -40 °C to +65 °C (-40 °F to +149 °F).
2. Storage Ambient Temperature Range: -40 °C to +70 °C (-40 °F to +158 °F).
3. Relative Humidity: Capable of operating in an ambient relative humidity range of 0% to 95%, non-condensing.
4. Altitude: Capable of operating in an altitude range of -200 feet to 10,000 feet. The maximum operating ambient temperature should be de-rated by 3 °C per 1000 feet above 6562 feet.

2.3 Compliance Information

1. Safety Compliance: This panel is UL Recognized for use in DC Power Distribution Centers for Communications Equipment.
2. NEBS Compliance: Compliance verified by a Nationally Recognized Testing Laboratory (NRTL) per GR-1089-CORE and GR-63-CORE. Contact Vertiv for NEBS compliance reports.
3. GR-3108: GR-3108 Class 2 Compliant.

2.4 Dimensions and Weight

See **Figure 2.1**.

Figure 2.1 Dimensions and Weight

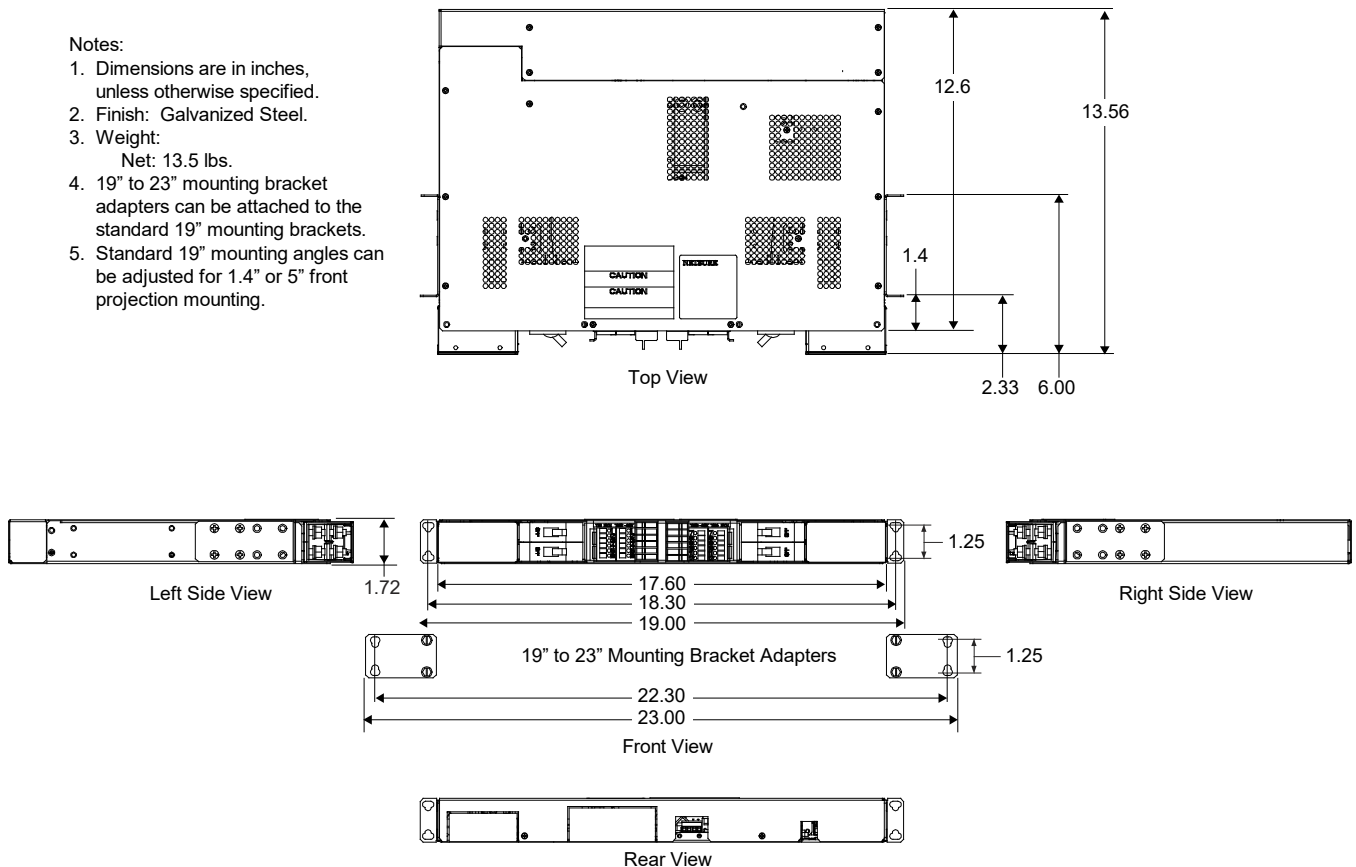

3 Accessories

Order the following by part number as required.

3.1 23” Mounting Bracket Adapter Plates, P/N 563148

Provides two (2) mounting bracket adapters to install the shelf in a 23” relay rack or cabinet rack. Attaches to the 19” standard brackets to allow 23” mounting.

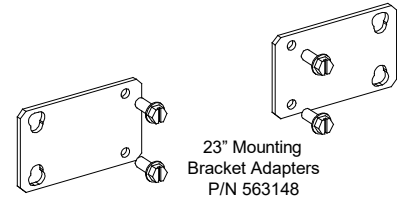

3.2 Bullet Nose Type Load Distribution Circuit Breakers

The distribution unit holds up to four (4) single-pole or up to two (2) double-pole bullet nose-type load distribution circuit breakers.

Order circuit breakers as required per **Table 3.1**. When ordering 2-pole devices, a “Special Application Crimp Lug / Strap Combination” must be ordered per device. See “Special Application Crimp Lug / Strap Combination” on page 6. See **Table 5.2** for recommended load distribution wire sizes and lugs. Load should not exceed 80% of device rating.

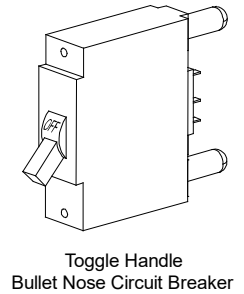

3.3 Bullet Nose Bypass Busbar with Handle, P/N 563020

Replaces a bullet nose circuit breaker when a protective or disconnect device is not required.



NOTE! The distribution unit holds up to four (4) bypass busbars.

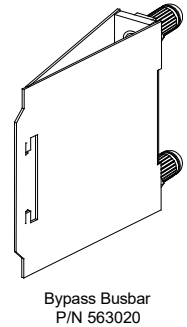

3.4 GMT Load Distribution Fuses

The distribution unit holds up to twelve (12) GMT load distribution fuses.

Order GMT fuses as required per **Table 3.2**.

When used for power distribution, load should not exceed 80% of device rating, except 10 A and 15 A fuses, for which load should not exceed 70% of device rating.

Table 3.1 Toggle Handle Bullet Nose Type Circuit Breakers

Ampere Rating	Number of Poles	Number of Mounting Positions Required	Part Number	
			Electrical Trip ¹ (White Handle)	Electrical / Mechanical Trip ² (Black Handle)
1	1	1	102272	101596
3	1	1	102273	101597
5	1	1	102274	101598
10	1	1	102275	101599
15	1	1	102276	101600
20	1	1	102277	101601
25	1	1	102278	101602
30	1	1	102279	101603
35	1	1	102280	101604
40	1	1	102281	101605
45	1	1	121998	121997
50	1	1	102282	101606
60	1	1	102283	101607
70	1	1	102284	101608
75	1	1	102285	101609
80	1	1	121996	121995
90	1	1	138887	138888
100	1	1	102286	101610
125	2	2	516991	516838
150	2	2	516993	516839

Circuit Breaker Alarm Operation:

- ¹ Provides an alarm during an electrical trip condition only.
- ² Provides an alarm during an electrical or manual trip condition.

Table 3.2 GMT Fuses

Ampere Rating	Part Number	Fuse Color
18/100 (GMT-A)	248610301	--
1/4	248610200	Violet
1/2	248610300	Red
3/4	248610500	Brown
1-1/3	248610700	White
2	248610800	Orange
3	248610900	Blue
5	248611000	Green
7-1/2	248611300	Black-White
10	248611200	Red-White
15	248611500	Red-Blue
Replacement Safety Fuse Cover (GMT-Y)	102774	--
Replacement Dummy Fuse	248872600	--

3.5 Lugs

Standard Crimp Lugs

For use on the front circuit breaker load busbars and rear input busbars.

Specify part number from **Table 3.3** for desired lead size.

Maximum single lug size for front breaker connections is 2 AWG narrow tongue lug P/N 140541.

Maximum lug size for rear input landing point connections is 1/0 AWG flex wire lug P/N 112902.

Table 3.3 Crimp Lug, Two-Hole, 1/4" Bolt Clearance Hole, 5/8" Centers

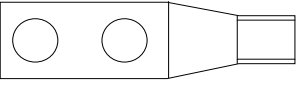
Lead Size	Part Number	
14-10 AWG	245342300	
8 AWG	245390200	
6 AWG	245346700	
4 AWG	245346800	
2 AWG	245346900	
2 AWG	140541 (Narrow Tongue)	
1/0 AWG	112902 (Narrow Tongue) (Flex Wire)	

Note: Lugs should be crimped per lug manufacturer's specifications.

Special Application Crimp Lug / Strap Combination

Straps two circuit breaker wiring positions together, and provides a crimp-type lug which allows distribution wiring up to 4/0 AWG. Designed for use with 125 A and larger bullet nose-type circuit breakers, which require two mounting positions.

Specify part number from **Table 3.4** for desired lead size.

Maximum double lug size for front breaker connections is 4/0 AWG lug P/N 245393800.

Table 3.4 Special Application Crimp Lug / Strap Combination (Two-Hole Lug, 1/4" Bolt Clearance Hole, 5/8" Centers)

Lead Size	Part Number
1/0 AWG	245393500
2/0 AWG	245393600
3/0 AWG	245393700
4/0 AWG	245393800

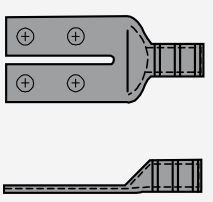

4 Installing the Distribution Unit

4.1 General

This product is intended for installation in network telecommunication facilities (CO, vault, hut, or other environmentally controlled electronic equipment enclosure).

This product is intended to be connected to the common bonding network in a network telecommunication facility (CO, vault, hut, or other environmentally controlled electronic equipment enclosure).

4.2 Securing the Distribution Unit to a Relay Rack or a Cabinet Equipment Rack (if required)



DANGER! If the distribution unit is mounted in a relay rack, the relay rack must be securely anchored to the floor before the distribution unit is installed.

The distribution unit is designed to mount in a standard 19" relay rack or equipment rack having 1" or 1-3/4" multiple drillings. 23" mounting bracket adapter plates are available. Refer to **Figure 2.1** on page 2 for overall dimensions.

Procedure

1. For 23" mounting, attach the 23" mounting bracket adapter plates to the standard 19" mounting brackets.
2. Position the distribution unit in the relay rack or cabinet equipment rack.
3. Secure the distribution unit to the relay rack or cabinet equipment rack using hardware as shown in **Figure 4.1** (see **Figure 4.1** for recommended torque). Use grounding washers as indicated in **Figure 4.1**.



NOTE! Install (orient) the ground washers so the teeth dig into the mounting angles for a secure ground connection.



NOTE! Compliance with Telcordia GR-1089-CORE requires that prior to mounting the system to the equipment rack: All paint must be removed from the front surface of each equipment rack rail where it mates with a shelf-mounting bracket, so that good metal-to-metal contact can be established between the shelf and rack.

- The shelf-to-rack mating surfaces must be cleaned.
- Electrical anti-oxidizing compound must be applied to the shelf-to-rack mating surfaces.

Figure 4.1 Mounting the Distribution Unit in a Relay Rack or a Cabinet Equipment Rack

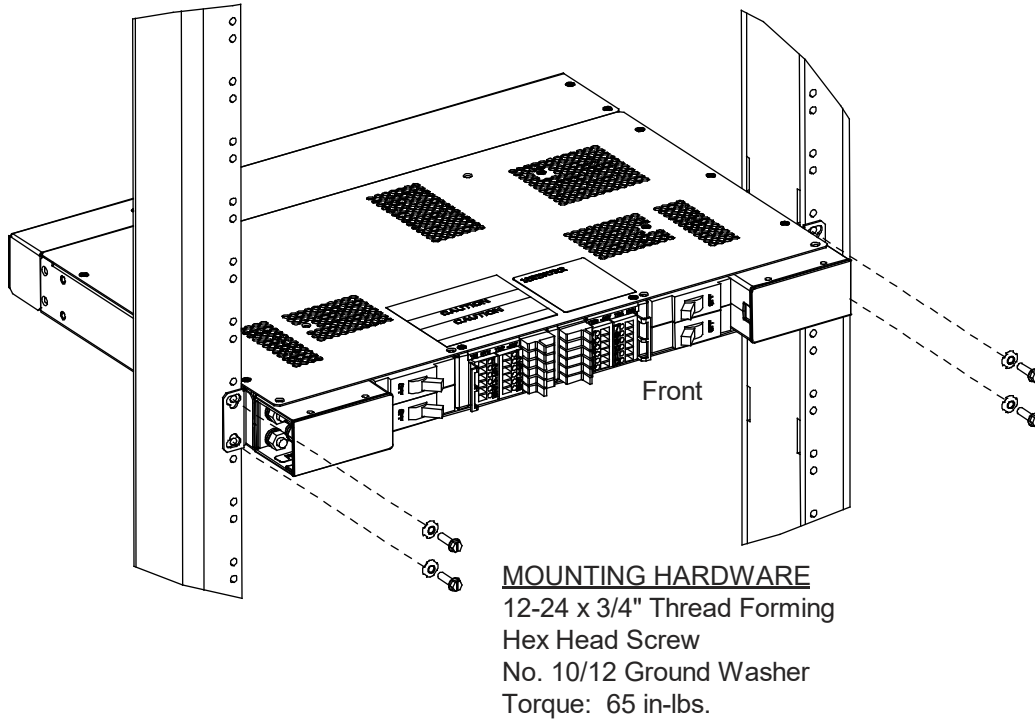

4.3 Installing Circuit Breakers and Fuses

Refer to “Specifications” on page 1 for any temperature, sizing, and spacing restrictions.

GMT Load Distribution Fuses

Procedure

1. Install correctly sized GMT fuses into the fuseholders located on the front of the distribution unit, as required. If a dummy fuse is installed, first remove the dummy fuse. Install a safety fuse cover over each GMT fuse. Install a dummy fuse in all unused fuse positions. See **Figure 4.2**.

Figure 4.2 Installing GMT Load Distribution Fuses

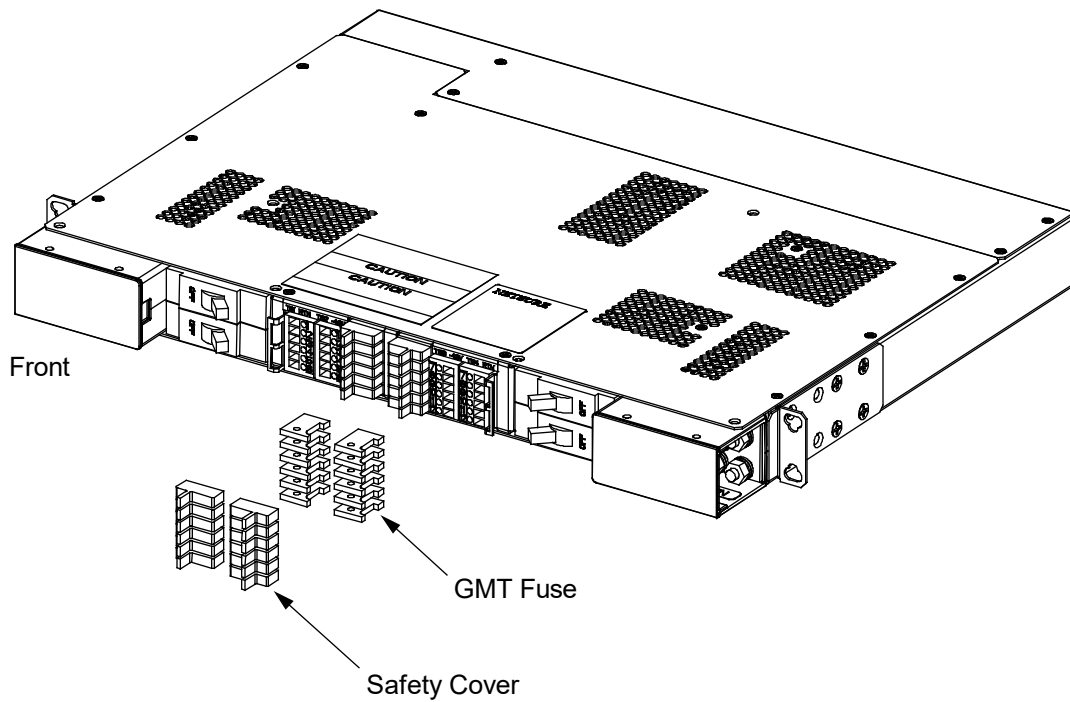

Installing Bullet Nose Type Circuit Breakers

Procedure

1. Ensure that the circuit breaker is in the OFF position and is of the correct rating. Orient the circuit breaker as shown in **Figure 4.3**. Insert the terminals on the rear of the circuit breaker into their corresponding sockets on the distribution unit. Ensure the alarm contact on the back of the circuit breaker makes contact with the alarm terminal on the distribution unit. Push distribution device in firmly until fully seated in the distribution unit.

Figure 4.3 Installing Bullet-Nose-Type Load Distribution Circuit Breakers

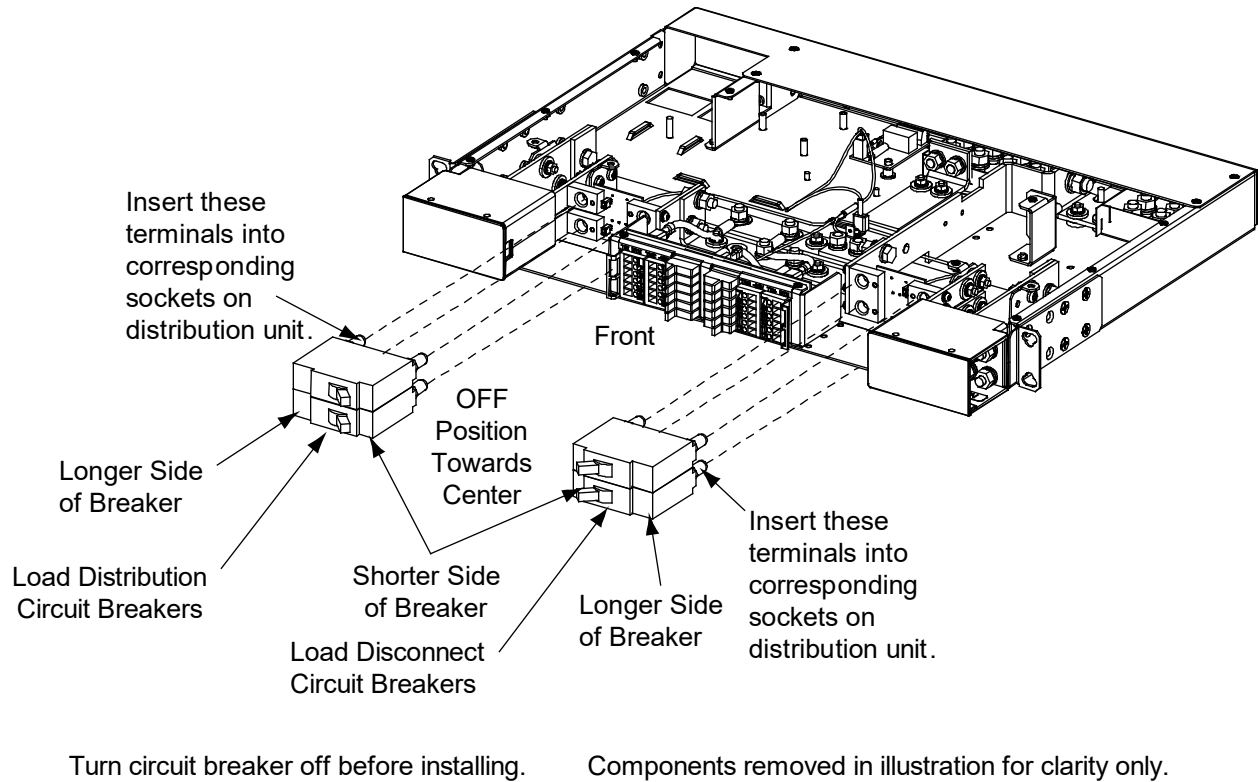

5 Making Electrical Connections

5.1 Important Safety Instructions



DANGER! Adhere to the “Important Safety Instructions” presented at the front of this document.



WARNING! When this panel is used in non-factory integrated systems, external branch circuit protection is required for all input feeds.

5.2 Wiring Considerations

All wiring, branch circuit protection, and grounding should follow the current edition of the American National Standards Institute (ANSI) approved National Fire Protection Association's (NFPA) National Electrical Code (NEC), and applicable local codes. For operation in countries where the NEC is not recognized, follow applicable codes.

Refer to **Table 5.1** for supplemental lug crimping information when using the special application crimp lug / strap combination.

Table 5.1 Supplemental Lug Crimping Information when Using the Special Application Crimp Lug / Strap Combination

Crimp Lug Part No.		Crimp Tool Required ¹ , T&B Model TBM12 or TBM15 Hydraulic Heads		
		Color Key	Die Index/ Code No.	Die Cat. Number
245393500	Burndy: YA25L-4TCG1	Pink	42H	15508
245393600	Burndy: YA26L-4TCG1	Black	45	15526
245393700	Burndy: YA27L-4TCG1	Orange	50	15530
245393800	Burndy: YA28L-4TCG1	Purple	54H	15511

¹ The lugs should be crimped to the specifications given in the manufacturer's instructions furnished with the crimp tool or lug.

5.3 Relay Rack / Cabinet Frame Grounding Connection



NOTE! This applies to the relay rack or cabinet equipment rack the distribution unit is installed in.

For relay rack / cabinet frame grounding requirements, refer to the current edition of the American National Standards Institute (ANSI) approved National Fire Protection Association's (NFPA) National Electrical Code (NEC), applicable local codes, and your specific site requirements.

5.4 Distribution Unit Frame Grounding Connection

For distribution unit frame grounding requirements, refer to the current edition of the American National Standards Institute (ANSI) approved National Fire Protection Association's (NFPA) National Electrical Code (NEC), applicable local codes, and your specific site requirements.

Procedure

1. The frame grounding connection to the distribution unit is made by using grounding washers with the mounting hardware used to secure the distribution unit to the relay rack or cabinet. Refer to “Securing the Distribution Unit to a Relay Rack or a Cabinet Equipment Rack” on page 6. Ensure that the relay rack or cabinet is properly grounded.



NOTE! An M4 frame ground stud is located on the rear of the distribution unit. Provide a grounding lead to this connection point, if required. Refer to **Figure 5.1** for location.

Figure 5.1 Distribution Unit Frame Grounding Connection Points

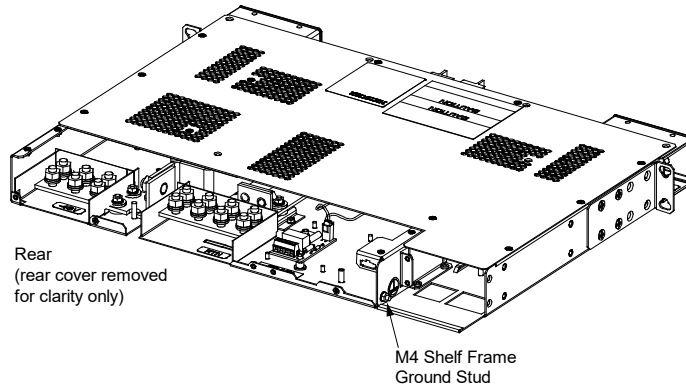

5.5 External Circuit Breaker / Fuse Alarm Connections

External circuit breaker alarm / fuse alarm wiring is made to terminal block J3 located on alarm circuit card P/N 541183. Refer to **Figure 5.2** for location. Terminal block J3 accepts a wire size in the range of 26 AWG to 14 AWG. Recommended torque is 0.5 Nm to 0.6 Nm.

- If a circuit breaker or fuse in the distribution unit opens, relay contacts open between terminals 2 and 3 of J3 and relay contacts close between terminals 3 and 4 of J3. Normal operation provides close relay contacts between terminals 2 and 3 of J3 and open relay contacts between terminals 3 and 4 of J3.
- If a circuit breaker or fuse in the distribution unit opens, -48 VDC is provided at terminal 1 of J3.

Figure 5.2 External Circuit Breaker / Fuse Alarm Connections

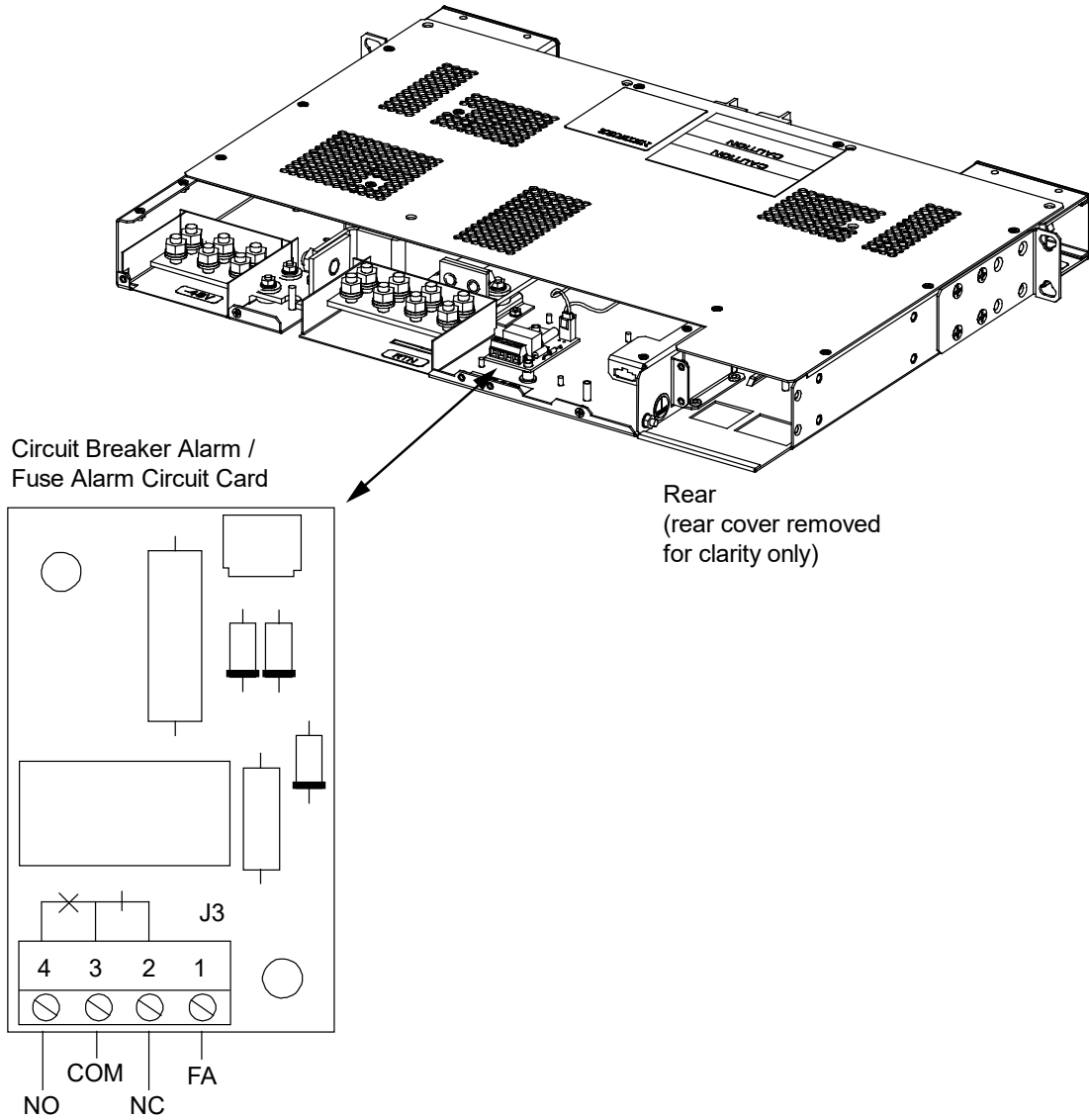

Relay shown in the deenergized state.
Relay is normally deenergized and energizes during an alarm condition.

5.6 Load Distribution Wiring to GMT Fuse Blocks



WARNING! Observe proper polarity when making load connections.



NOTE! When used for power distribution, load should not exceed 80% of device rating, except 10 A and 15 A fuses, for which load should not exceed 70% of device rating.

Load and load return leads are connected to screw-type terminal blocks located on the front of the distribution unit (refer to **Figure 5.3**). Refer to **Figure 5.3** also for terminal block wire size capacity and recommended torque.

The rating of the distribution device determines the wire size requirements. Refer to the American National Standards Institute (ANSI) approved National Fire Protection Association's (NFPA) National Electrical Code (NEC) and applicable local codes.

5.7 Load Distribution Wiring to Distribution Circuit Breakers



WARNING! Observe proper polarity when making load connections.



NOTE! Load should not exceed 80% of device rating.

Load and load return leads terminated in two-hole lugs are connected to threaded studs located on the front sides of the distribution unit (refer to **Figure 5.3**). Refer to **Figure 5.3** also for stud size/spacing and recommended torque.

The rating of the distribution device determines the wire size and lug requirements. Refer to the American National Standards Institute (ANSI) approved National Fire Protection Association's (NFPA) National Electrical Code (NEC) and applicable local codes. All lugs for customer connections must be ordered separately. See **Table 3.3** and **Table 3.4** for available lugs.

For wire size and lug selection, refer to **Table 5.2**.

**Table 5.2 Recommended Load Distribution Wire Size and Lug Selection for Bullet Nose-Type Circuit Breaker
(Load and Load Return) (cont'd on next page)**

Circuit Breaker Amperage	Recm 90 °C Wire Size ⁽¹⁾						
	14 AWG	12 AWG	10 AWG	8 AWG	6 AWG	4 AWG	2 AWG
	Loop Length (feet) ⁽²⁾						
1, 3, 5, 10 A	37 ^(3, 4, 5)	58 ^(3, 4, 5)	93 ^(3, 4, 5)	148 ^(3, 4, 5)	236 ^(3, 4, 5)	376 ^(3, 4, 5)	597 ^(3, 4, 5)
15 A	24 ^(3, 4)	39 ^(3, 4, 5)	62 ^(3, 4, 5)	99 ^(3, 4, 5)	157 ^(3, 4, 5)	250 ^(3, 4, 5)	398 ^(3, 4, 5)
20 A	--	29 ^(3, 4)	46 ^(3, 4, 5)	74 ^(3, 4, 5)	118 ^(3, 4, 5)	188 ^(3, 4, 5)	298 ^(3, 4, 5)
25 A	--	--	37 ^(3, 4)	59 ^(3, 4, 5)	94 ^(3, 4, 5)	150 ^(3, 4, 5)	239 ^(3, 4, 5)
30 A	--	--	31 ^(3, 4)	49 ^(3, 4, 5)	78 ^(3, 4, 5)	125 ^(3, 4, 5)	199 ^(3, 4, 5)
35 A	--	--	--	42 ^(3, 4)	67 ^(3, 4, 5)	107 ^(3, 4, 5)	170 ^(3, 4, 5)
40 A	--	--	--	37 ^(3, 4)	59 ^(3, 4, 5)	94 ^(3, 4, 5)	149 ^(3, 4, 5)
45 A	--	--	--	33 ^(3, 4)	52 ^(3, 4)	83 ^(3, 4)	132 ^(3, 4)
50 A	--	--	--	29 ⁽³⁾	47 ^(3, 4)	75 ^(3, 4)	119 ^(3, 4)
60 A	--	--	--	--	39 ^(3, 4)	62 ^(3, 4)	99 ^(3, 4)
Recommended Crimp Lug							
Lug	245342300 ⁽⁶⁾	245342300 ⁽⁶⁾	245342300 ⁽⁶⁾	245390200 ⁽⁶⁾	245346700 ⁽⁶⁾	245346800 ⁽⁶⁾	140541 ⁽⁶⁾

Table 5.2 Recommended Load Distribution Wire Size and Lug Selection for Bullet Nose-Type Circuit Breaker (Load and Load Return) (cont'd from previous page)

Circuit Breaker Amperage	Recm 90 °C Wire Size ⁽¹⁾				
	4 AWG	2 AWG	1/0 AWG	2/0 AWG	3/0 AWG
	Loop Length (feet) ⁽²⁾				
70 A	53 ^(3,4)	85 ^(3,4)	135 ⁽³⁾	--	--
75 A	50 ^(3,4)	79 ^(3,4)	126 ⁽³⁾	--	--
80 A	47 ⁽³⁾	74 ^(3,4)	118 ⁽³⁾	--	--
90 A	--	66 ^(3,4)	105 ⁽³⁾	133 ⁽³⁾	--
100 A	--	59 ^(3,4)	95 ⁽³⁾	119 ⁽³⁾	--
125 A	--	--	76 ⁽³⁾	95 ⁽³⁾	120 ⁽³⁾
150 A	--	--	63 ⁽³⁾	79 ⁽³⁾	100 ⁽³⁾
Recommended Crimp Lug					
Lug	245346800 ⁽⁶⁾	140541 ⁽⁶⁾	245393500 ⁽⁷⁾	245393600 ⁽⁷⁾	245393700 ⁽⁷⁾

Notes to Table 5.2:

- ¹ Wire sizes based on recommendations of the American National Standards Institute (ANSI) approved National Fire Protection Association's (NFPA) National Electrical Code (NEC). Table 310.15 (B) (16) for copper wire at 90 °C conductor temperature. For operation in countries where the NEC is not recognized, follow applicable codes.
- ² Recommended wire sizes are sufficient to restrict voltage drop to 1.0 volt or less at listed branch current for the loop lengths shown. Loop length is the sum of the lengths of the positive and negative leads.
- ³ Wire Size / Loop Length Combination Calculated using 40 °C Ambient Operating Temperature.
- ⁴ Wire Size / Loop Length Combination Calculated using 50 °C Ambient Operating Temperature.
- ⁵ Wire Size / Loop Length Combination Calculated using 65 °C Ambient Operating Temperature.
- ⁶ These lugs are two-hole for 1/4" bolt clearance on 5/8" centers.
- ⁷ Special application crimp lug / strap combination (restrictions apply, see "Special Application Crimp Lug / Strap Combination" on page 6).

Figure 5.3 Load Distribution Wiring and Input Wiring

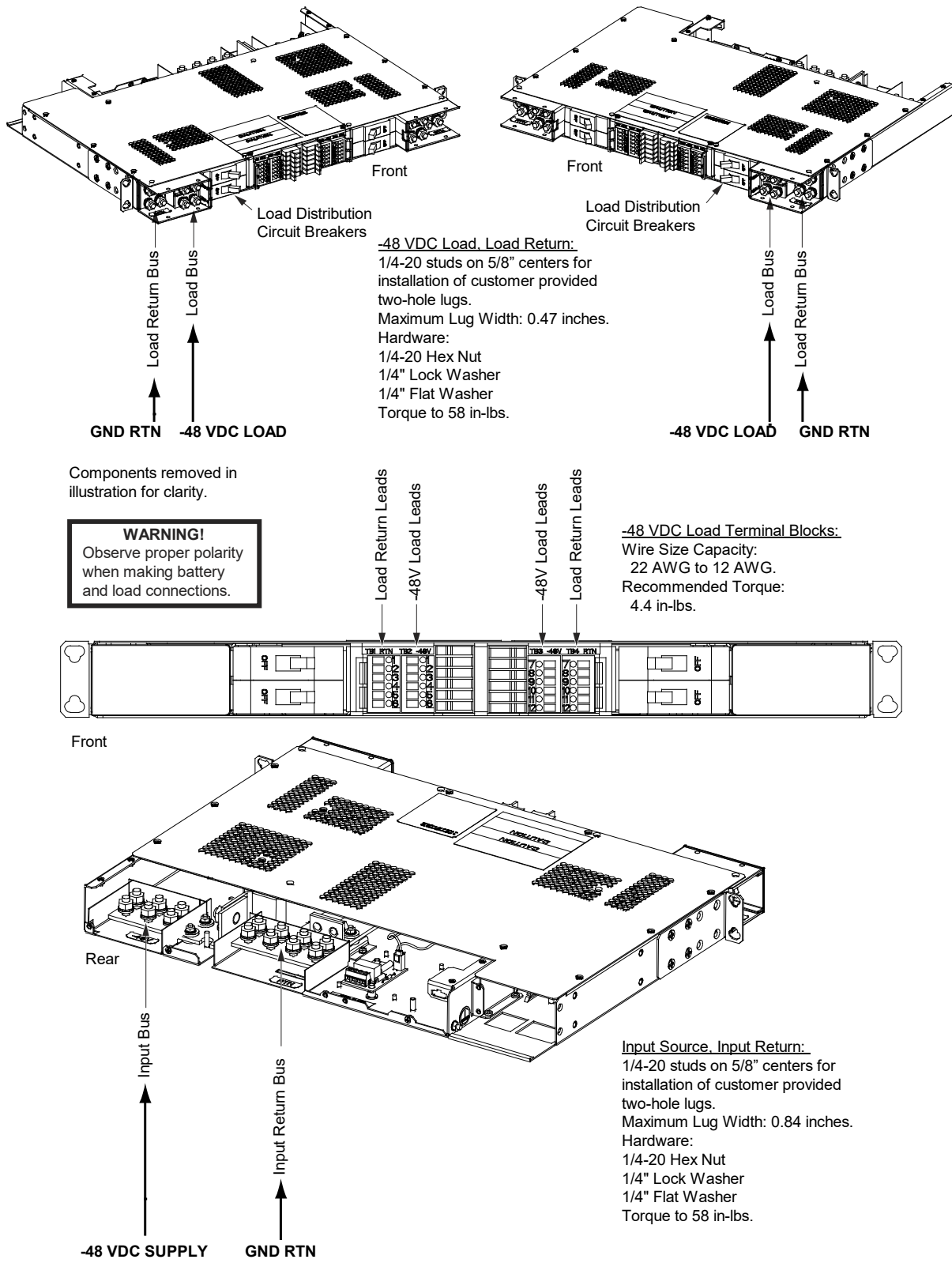

5.8 Input Wiring



WARNING! Observe proper polarity when making input connections.

Input source and input return leads terminated in two-hole lugs are connected to threaded studs located on the rear inside of the distribution unit (refer to **Figure 5.3**). Refer to **Figure 5.3** also for stud size/spacing and recommended torque.

Input wire size and lug requirements vary depending on power requirements, therefore no specific information is provided for wire size. Refer to **Table 5.3** for recommended wire sizes and lugs at rated maximum assembly load and other various loads. Note that loads typically should not exceed 80% of capacity; therefore, input wires have been sized for an overcurrent protection device rated at 125% of the expected load. All lugs for customer connections must be ordered separately. See **Table 5.3** for available lugs.



NOTE! The DC return connection to this system can remain isolated from system frame and chassis (DC-I).

Table 5.3 Recommended Input External Branch Circuit Protection, Wire Sizes, and Lug

External Overcurrent Protection Device Rating	Ambient Operating Temperature ⁽¹⁾	Loop Length (Ft) 1.0 Voltage Drop ⁽²⁾	Recm 90°C Wire Size (AWG) ⁽¹⁾	Recommended Crimp Lug ⁽³⁾
150 A	40°C	63	1/0	112902
125 A	40°C	76	1/0	112902
100 A	40°C	59	2	245346900

- ¹ Wire sizes based on recommendations of the American National Standards Institute (ANSI) approved National Fire Protection Association's (NFPA) National Electrical Code (NEC). Table 310.15 (B) (16) for copper wire at 90 °C conductor temperature. For operation in countries where the NEC is not recognized, follow applicable codes.
- ² Recommended wire sizes are sufficient to restrict maximum voltage drop to 1.0 volt at rated full load output current of the shelf for the loop lengths shown in this column. Loop length is the sum of the lengths of the positive and negative leads.
- ³ These lugs are two-hole for 1/4" bolt clearance on 5/8" centers. Lugs should be crimped per lug manufacturer's specifications.

6 Initial Startup

Procedure

1. Apply input power to the distribution unit.
2. Place each distribution circuit breaker to the ON position.

7 Troubleshooting and Repair

7.1 Contact Information

Refer to Section 4154 (provided with your customer documentation) for support contact information.

7.2 Replacement Procedures



DANGER! Adhere to the “Important Safety Instructions” presented at the front of this document.

7.2.1 Replacing a Distribution Device

Replace distribution devices with the same type and rating.

Replacing a GMT Distribution Fuse

Procedure

1. Refer to **Figure 4.2** and replace the fuse. Ensure a safety fuse cover is installed on the replacement fuse, as shown in **Figure 7.1**.
2. Verify no alarms are active.

Figure 7.1 Installation of Safety Fuse Covers

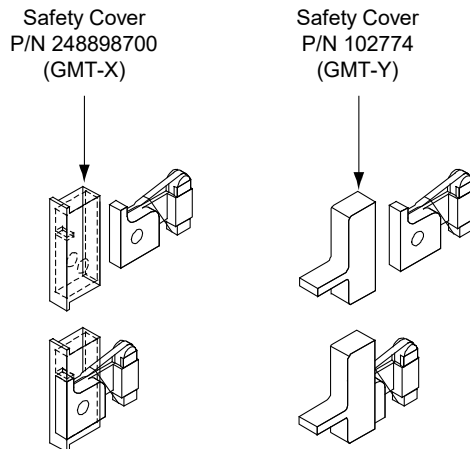

Replacing a Bullet Nose Circuit Breaker

Procedure

1. Operate the defective circuit breaker to the OFF position.
2. Gently rock the defective circuit breaker back and forth while pulling firmly outward until the breaker is free from the distribution unit.
3. Ensure that the replacement circuit breaker is in the OFF position, and is of the correct rating.
4. Orient the replacement circuit breaker as shown in **Figure 4.3**. Insert the terminals on the rear of the circuit breaker into their corresponding sockets on the distribution unit. Ensure the alarm contact on the back of the circuit breaker makes contact with the alarm terminal on the distribution unit. Push distribution device in firmly until fully seated in the distribution unit.
5. Operate the replacement circuit breaker to the ON position.
6. Verify no alarms are active.

Connect with Vertiv on Social Media



<https://www.facebook.com/vertiv/>



<https://www.instagram.com/vertiv/>



<https://www.linkedin.com/company/vertiv/>



<https://www.twitter.com/vertiv/>



Vertiv.com | Vertiv Headquarters, 1050 Dearborn Drive, Columbus, OH, 43085, USA

© 2022 Vertiv Group Corp. All rights reserved. Vertiv™ and the Vertiv logo are trademarks or registered trademarks of Vertiv Group Corp. All other names and logos referred to are trade names, trademarks or registered trademarks of their respective owners. While every precaution has been taken to ensure accuracy and completeness here, Vertiv Group Corp. assumes no responsibility, and disclaims all liability, for damages resulting from use of this information or for any errors or omissions. Specifications, rebates and other promotional offers are subject to change at Vertiv's sole discretion upon notice.