



High PowerBar (HPB) UL 857

Installer/User Guide

The information contained in this document is subject to change without notice and may not be suitable for all applications. While every precaution has been taken to ensure the accuracy and completeness of this document, Vertiv assumes no responsibility and disclaims all liability for damages result from use of this information or for any errors or omissions.

Refer to local regulations and building codes relating to the application, installation, and operation of this product. The consulting engineer, installer, and/or end user is responsible for compliance with all applicable laws and regulations relation to the application, installation, and operation of this product.

The products covered by this instruction manual are manufactured and/or sold by Vertiv. This document is the property of Vertiv and contains confidential and proprietary information owned by Vertiv. Any copying, use, or disclosure of it without the written permission of Vertiv is strictly prohibited.

Names of companies and products are trademarks or registered trademarks of the respective companies. Any questions regarding usage of trademark names should be directed to the original manufacturer.

Technical Support Site

If you encounter any installation or operational issues with your product, check the pertinent section of this manual to see if the issue can be resolved by following outlined procedures.

Visit <https://www.vertiv.com/en-us/support/> for additional assistance.

TABLE OF CONTENTS

1 Important Safety Instruction	1
2 Introduction	3
3 Handling	5
3.1 Manual Lifting	5
3.2 Mechanical Lifting	5
3.3 Receiving and Inspection	5
3.4 Storage Instructions	5
4 Preparing for Installation	7
4.1 Required Tools	8
5 Busway Information	11
5.1 Common Terms	11
5.2 Identification	12
5.3 Phase Sequence	13
5.4 Mounting Orientation	14
5.5 Clearances and Obstructions	14
5.5.1 Busway Clearances	15
5.5.2 Busplug Clearances	16
5.6 Wall Penetrations and Fire Barriers	16
5.6.1 Wall Penetrations	16
5.6.2 Fire Barriers	17
5.7 Mounting Methods	20
5.7.1 Horizontal Orientation	20
6 Installation	23
6.1 Hanging Busway	23
6.1.1 Horizontal Hanging	23
6.1.2 Vertical Hanging	24
6.2 Joining Busway Sections	26
6.2.1 End to End Installation (Method A)	26
6.2.2 Side Installation (Method B)	35
6.3 End Cap	41
6.4 Cable End Box	42
6.5 Expansion Units	45
6.6 Busplug Slot Cover	47
6.7 Busplug	48
7 Pre-Energization	55
7.1 Pre-Energization Testing	55
8 Energizing	57

9 Maintenance of Busplug Module	59
Appendices	61
Appendix A: Technical Support and Contacts	61

1 Important Safety Instruction

All information provided in this instruction manual and additional referenced documentation must be reviewed and acknowledged by all personnel responsible for the use of the equipment. All models represented in this manual are for illustrative purposes only, due to the individual specifications associated with each customer. Vertiv will not assume responsibility for actual use established by the models.

Proper installation, operation, and maintenance are critical to the performance of the equipment. Correct operating conditions in terms of input voltage, current, and the fault capacities must be ensured at the time of installing the Vertiv™ High PowerBar (HPB) UL 857. Refer **ANSI C37.20.1** for abnormal operational conditions.



WARNING! Risk of electrical shock or burn. Turn off power to busway before installing, removing, or working on this equipment.

General instructions

- Read all the instructions included in this IUG before working with the equipment.
- Store and keep this IUG to ensure proper commissioning and maintenance to ensure the prolong use of the equipment.
- Install based on the design limitations as given in this IUG. The design limitations are presented on the main nameplate and must never be installed in applications that exceed the limits presented by the nameplate.
- Always follow standard safety protocols set forth by your company.
- Turn off all the power sources and de-energized the equipment before removing the covers and opening of doors of the equipment. All components must be locked out and tagged in line with standard protocol and ANSI Standard Z244.1 Control of Hazardous Energy – Lockout/Tagout.
- Wear PPEs while working on the switchboard.
- Only Vertiv qualified personnel must work.
- If additional information is needed, contact Vertiv representative.



WARNING! Failure to follow the provided guidelines. Can cause product damage, electrical failure of the busway, serious injury or death.



WARNING! Risk of improper use. Can cause product damage, serious injury or death. Use this equipment carefully as it operates at a maximum 600 V phase.



WARNING! Ensure complete electrical isolation (the busbar is disconnected from the supply of electrical energy), verification and lock out of supply devices in accordance with isolation procedures for the particular installation prior to carrying out any installation, inspection, or maintenance.



WARNING! Only Vertiv approved installation personnel may install this product. If training is required, contact Vertiv [Technical Support and Contacts](#) on page 61. Training is provided on site or at our manufacturing facility.



CAUTION: Do not use impact or power tools on any HPB hardware.

2 Introduction

The Vertiv™ High PowerBar (HPB) UL 857 installation manual is designed to assist in the safe handling and installation of the High Powerbar (HPB) UL system. These instructions are in addition to normal safe working practices as required by the local health and safety regulations. These instructions do not in any way advocate a departure from these requirements.

Vertiv supplies all busway sections tested in accordance with type test requirements as detailed in UL 857 and are subject to a full quality check before packaging.

To ensure that the busway remains in this condition as mentioned in UL 857 during transport, unpacking, and installation on site, it is important to study this document.

This page intentionally left blank

3 Handling

This chapter describes how to handle the unit or its modules during shipping, moving to storehouse, or moving to the installation site.



WARNING! Risk of improper moving, lifting, and handling. Can cause equipment damage, injury, or death. Verify that all lifting and moving equipment is rated for the weight of the unit before attempting to move, lift, remove packaging from the unit, or prepare the unit for installation. Refer to the local safety regulations about lifting and handling heavy loads.

3.1 Manual Lifting



WARNING! To reduce the risk of injury to personnel and equipment damage during transport and installation of busway section comply with local manual lifting regulation.



CAUTION: Personal protection equipment must be worn in accordance with health and safety regulations and specific site requirements. When lifting busway sections, care must be taken to lift each section along its center and not by the end sections or conductors.

3.2 Mechanical Lifting

Certain sections of the busway may require mechanical lifting due to their weight. Options for mechanical lifting include the use of genie lifts, forklifts, scissor lifts, and platform lifts. Prior to commencing any work, the installer is advised to perform a full risk assessment. It is imperative that the busway be securely fastened to the designated lifting apparatus before initiating the lifting process.

Maintaining strict adherence to the safe working load limits of the lifting apparatus is crucial during all phases of the operation. Also, it is essential to ensure that all equipment is used in strict accordance with the manufacturer's guidelines.

3.3 Receiving and Inspection

When the material is received, carefully inspect each box/crate for damage, including concealed issues. If any damage is detected, immediately inform the carrier and initiate the required claims process. In the absence of visible or concealed damage, the product is deemed suitable for storage or installation.

3.4 Storage Instructions

The Vertiv™ High PowerBar (HPB) UL 857 must be stored in a covered, clean, dry space which is climate controlled to prevent condensation. Prevent the busway from coming into contact with corrosive fumes, liquids, salts, or any other substances that can cause corrosion. Corrosion degrades the material and affect the performance of the busway.

NOTE: The busway will be delivered to the customer neatly stacked on a wooden pallet for ease of removal. The maximum recommended weight for pallets is 3000 kg (6600 lb). See BU1.1 for storage requirements.

NOTE: The busway is protected from minor water ingress by means of an overall outer polythene wrap. The stretch wrap must be left in position until the bar is mounted, and joint pack fitted.



CAUTION: Neglecting proper storage and protection of the busway may result in damage and void the warranty.

4 Preparing for Installation

Transport the busway to the installation site before unpacking. Each pallet will have a packing slip with a list of the parts. Unpack the pallet and check for any damage to the Vertiv™ PowerBar Busway. Each busway component is identifiable by a part number on the nameplate, corresponding to the part number on the busway installation drawings.

Inspect each busway component thoroughly for potential damage. If any damage is identified, promptly consult the factory. Ensure that contact surfaces are undamaged, clean, and dry. Avoid using abrasives on these electroplated surfaces. Check joint insulators for any cracks or signs of damage.

NOTE: If wiping down the busway, do not use any cleaners or solvents on the product or it may damage the nameplate data and plastic parts.

Conduct an insulation resistance test (Megger test) on each busway component at 1000 V, phase to phase (including neutral) and phase to ground. This test aids in detecting shipping and handling damage resulting in deterioration to the insulation integrity. Disconnect the busway from any line or load devices before performing the megger test.

Minimum megger test readings must not be less than 10 Mega Ohms for each component.



CAUTION: If megger test readings fall below 10 Mega Ohms, do not assemble the busway or apply power. Instead, contact Vertiv service team for further guidance.



CAUTION: Megger test must only be carried out by experienced personnel.

NOTE: Experienced personnel are skilled professionals with expertise in electrical systems, safety protocols, and analytical abilities to interpret test results accurately.

4.1 Required Tools

Figure 4.1 Tools Needed

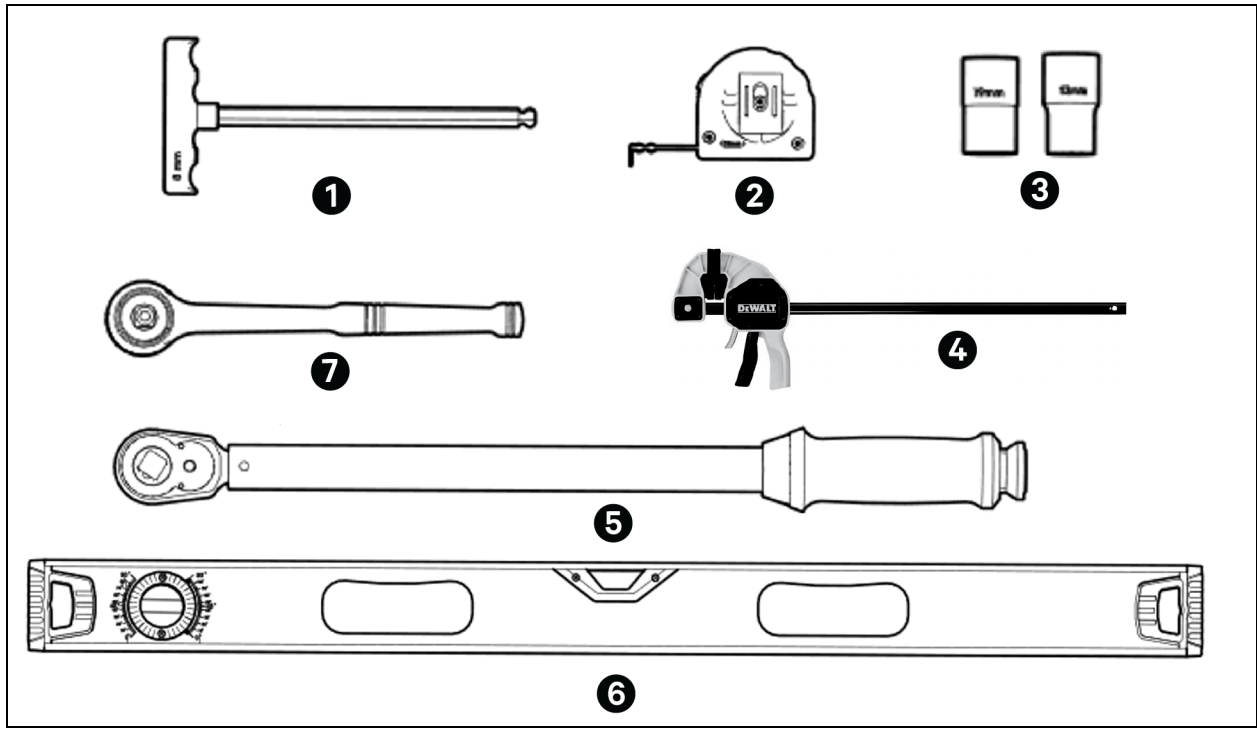

NOTE: Ensure all tools are on site a week prior to installation training.

Item	Description
1	T-handle 8 mm ball end hex
2	Metric Machinist Ruler (300mm) or measuring tape
3	19 mm deepwell socket and 13 mm socket
4	Dewalt (or equivalent) 600lb Clamps/Spreaders (Use 24" for 800 A to 2500 A, 36" for 3000 A, 52" for 4000 A to 5000A)
5	Socket wrench
6	Alignment laser or bubble level
7	Torque wrenches (with ranges from 10 Nm [7 ft-lbs] to 90 Nm [66 ft-lbs])

Table 4.1 Tool Kit List

Description	Quantity
HPB-GUIDE-COMB	4
HPB-JPJ-001 (HPB Joint Pack Jig 14.567" Long) -- Joint positioner	2
HPB-00000-00568 (Joint Pack Pusher Plate)	1
HPB-00000-00569 (Joint Pack Pusher Plate)	1
HPB-CAB-002 (Conductor Alignment Block)	1

Installation tool kit is comprised of the following installation tools for Vertiv™ PowerBar Busway installation.

NOTE: To order additional tool kit for installation use Part No. HPB-JP-INST-KIT.

NOTE: Ensure that personnel adhere to safety protocols by wearing the designated PPE during the busway installation process.

This page intentionally left blank

5 Busway Information

NOTE: Apply a plumb line or laser level from the start of the run to the end of the run as a guide for the installation of the busway run.

5.1 Common Terms

Table 5.1 Common Terms

Terms	Description
Qualified person	One who has skills and knowledge related to the construction and operation of electrical busway and installations and has received safety training to recognize and avoid the hazards involved.
Joint Pack (JP)	Bridge, splice and joint stack
Joint Splice Plate (JSP)	Outer earth plate of the joint pack
Joint Cover (JC)	Joint inspection cover
Joint Block (JB)	Cast earth mounting block for joint cover
Busbar or bar	Conductor (aluminum or copper)
Housing	Outer aluminum casing of the busway
Earth Splice Plate (ESP)	Busway housing earth splice plate
Busplug outlet	Distribution busway plug-in location
Busplug	Busplug Fitting tap off box (TOB)
Cable End Box (CEB)	Cable end feed or tap box
RMS	Root mean square
IP Rating	Ingress protection rating (for example: IP55)
SCCR	Short circuit current rating
Isolated ground	Epoxy-coated ground bar, separated from housing
Bare Earth (BE)	Non-epoxy coated ground bar, bonded to housing ground.

5.2 Identification

Figure 5.1 Typical Part Code Layout

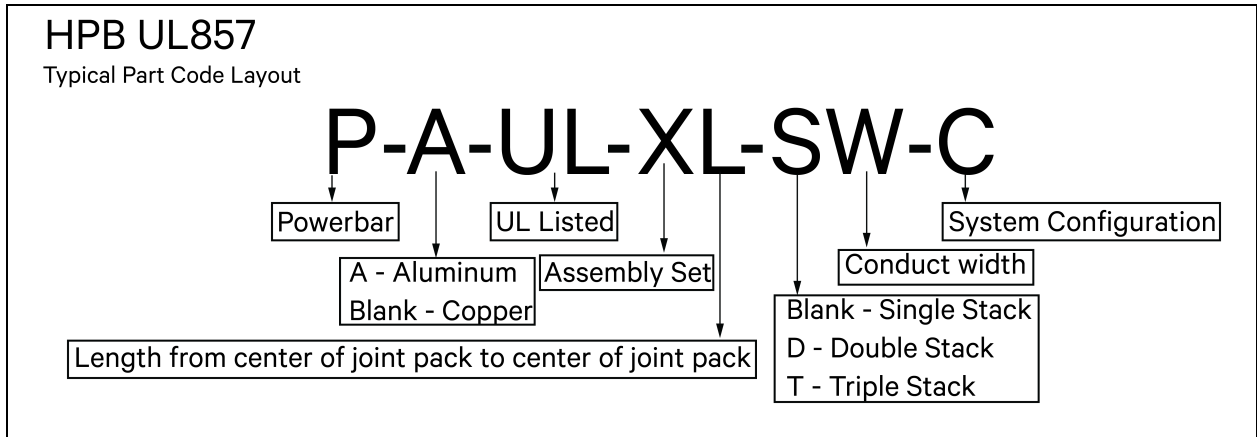

Table 5.2 Model Description

1	2	3	4	5 and 6	7
P	A	UL	XL	SW	C

Table 5.3 Model Number Digit Description

Digit	Description
1	Product line <ul style="list-style-type: none"> P - PowerBar
2	Conductor material <ul style="list-style-type: none"> A - Aluminum, copper, if not present Blank - Copper
3	UL- UL listed, UL13 - UL13 applications
4	XL- Assembly set (such as panel flange (PF), feeder length (FL), distribution length (DL) with tap off outlets). Numbers = length of conductors in inches.
5 and 6	PowerBar configuration <ul style="list-style-type: none"> Blank - Single D - Double stack T - Triple stack W - Conductor width in mm
7	C - Busbar conductor system configurations (such as TP, TPNE)

5.3 Phase Sequence

There are six different types of system configurations:

Figure 5.2 Three-phase (TP) Configuration

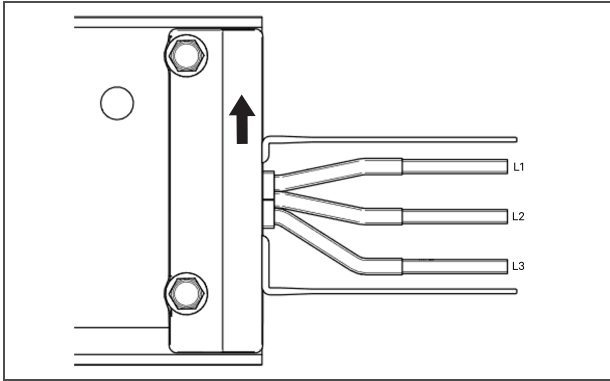

Figure 5.3 Three-phase with Isolated Ground (TPE) Configuration

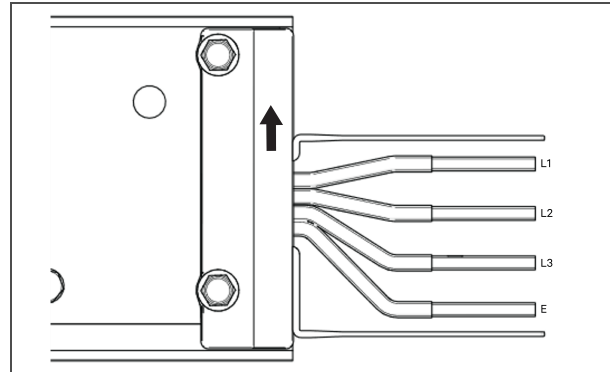

Figure 5.4 Three-phase with Bare Ground (TPBE) Configuration

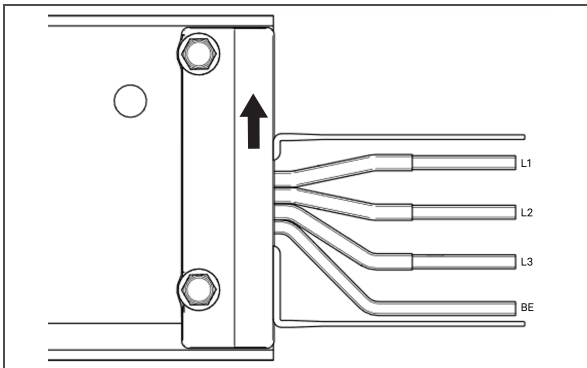

Figure 5.5 Three-phase with Neutral (TPN) Configuration

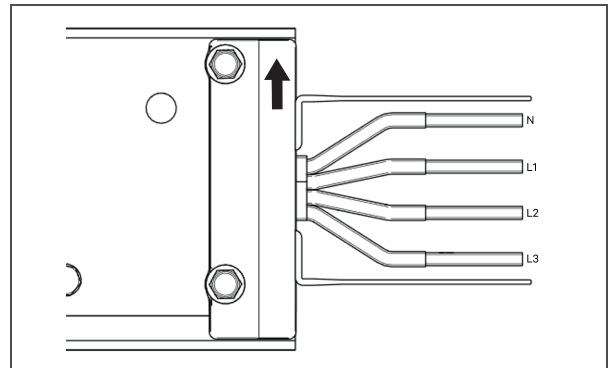

Figure 5.6 Three-phase with Neutral and Isolated Ground (TPNE) Configuration

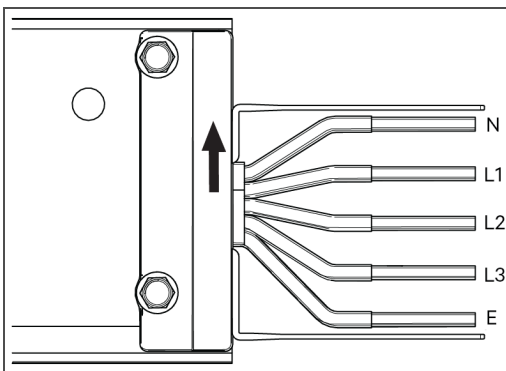
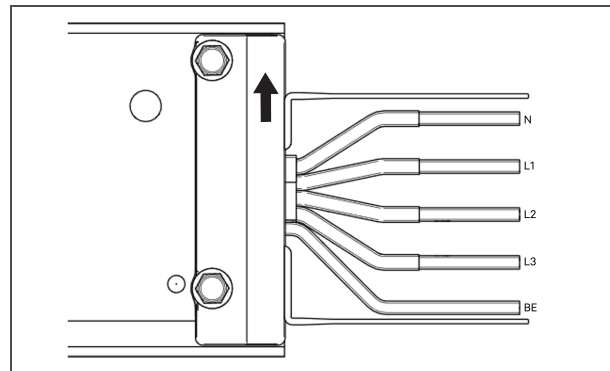

Figure 5.7 Three-phase with Neutral and Bare Ground (TPNBE) Configuration



Isolated ground configurations utilize a ground (earth) conductor that is epoxy coated and separated for the entire busbar run. Uninsulated ground (bare earth, BE) configurations utilize a bare ground conductor in contact with the busway and joint pack housings.

Configurations without a ground (earth) conductor utilize the busway housing as the ground conductor. Typical busway phase sequence is NABCG from top to bottom. The arrow is always pointing towards phase A. Unless otherwise noted, the joint block arrow points to the bolt nuts.

NOTE: When phase transpositions are requested, this sequence may change.

5.4 Mounting Orientation

The following figures give the orientation of horizontal edgewise, flatwise, and vertical (riser).

Figure 5.8 Flat and Edge

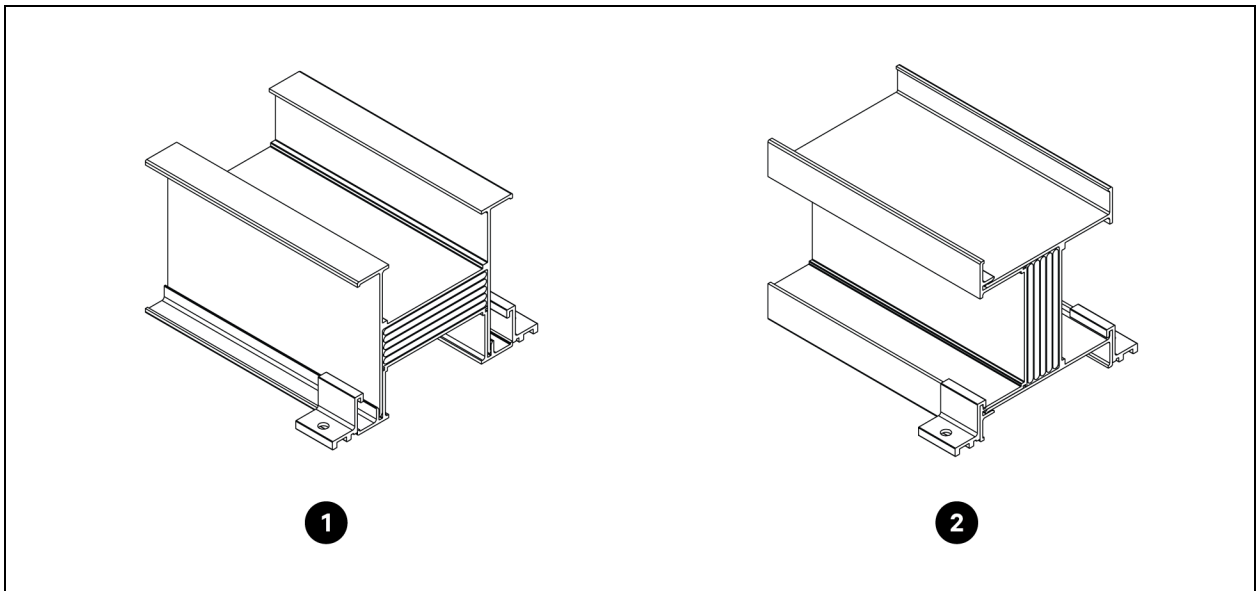

Item	Description
1	Flat
2	Edge

5.5 Clearances and Obstructions

Minimum distances for feeder busways are:

- 6 in. (152.4 mm) from a ceiling.
- 4 in. (101.6 mm) from a wall.
- 6 in. (152.4 mm) between busway sections.

Typical clearances shown. For clearances for specific busway/busplug arrangements, contact Vertiv.

5.5.1 Busway Clearances

NOTE: Other obstructions (conduits, water pipes, HVAC, building structures and facilities, other electrical equipment) shall be located using the same clearances. Otherwise follow local rules for clearances (NEMA BU 1.1-2010).

NOTE: Before installing the busway under sprinklers or HVAC ducts that might drip water onto the busway, contact Vertiv representative.

Figure 5.9 Busway Clearances

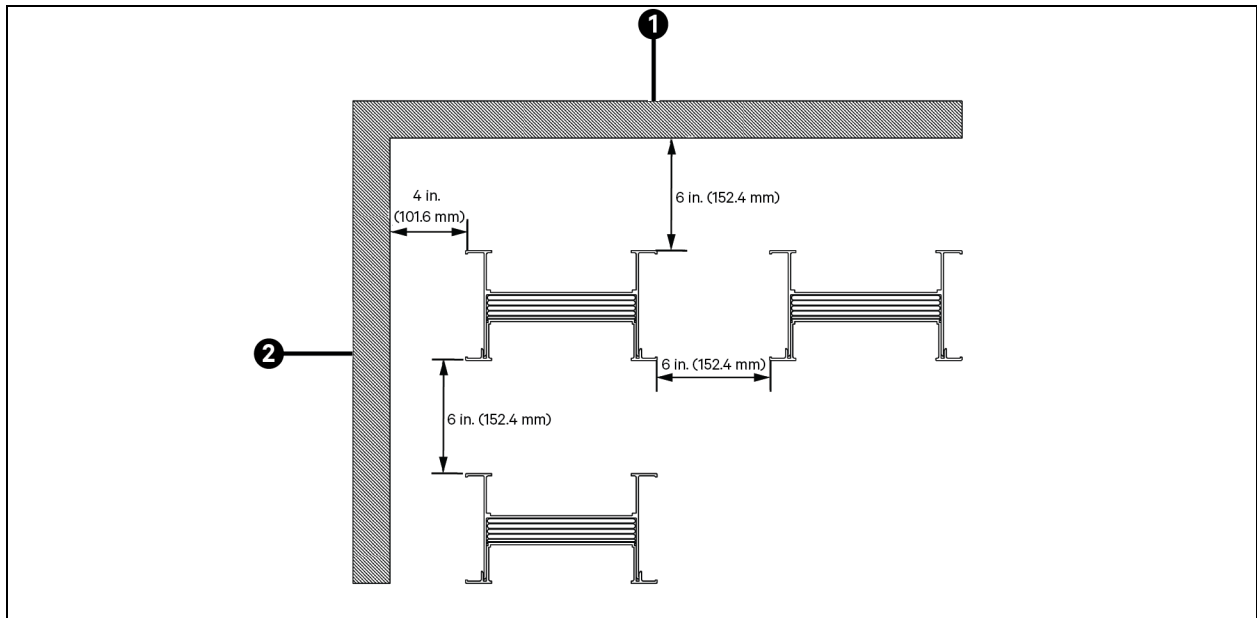

Item	Description
1	Ceiling
2	Wall

Following are the obstructions:

- Show different conditions.
- Busway next to each other.
- Other building conflicts or facilities near the busway (conduits).
- Pedestrian or safety concerns.
- Busway clearances.

NOTE: Other obstructions (conduits, water pipes, HVAC, building structures, and other electrical equipment) to be located using the same clearances. Otherwise follow local rules for clearances (NEMA BU 1.1-2010). Avoid installing busway in proximity to sprinkler/water piping runs.

5.5.2 Busplug Clearances

Figure 5.10 Top View of Horizontal Flat Mounted Distribution Busway

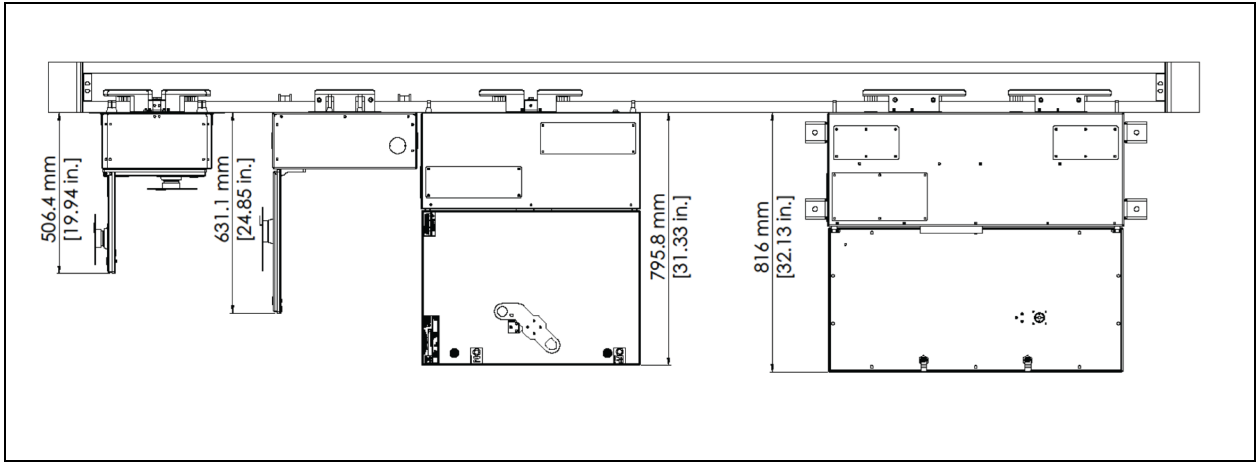

Typical Busplug door swing dimensions shown, installer must ensure their product (which may differ from these standard dimensions) has sufficient clearance for the door to open 90 degrees, per NEC requirements.

5.6 Wall Penetrations and Fire Barriers

5.6.1 Wall Penetrations

Ensure wall penetration clearances of 2 in. (51 mm) on all sides of the busway. See Figure 5.11 below.

Figure 5.11 Minimum Wall Penetration Clearances

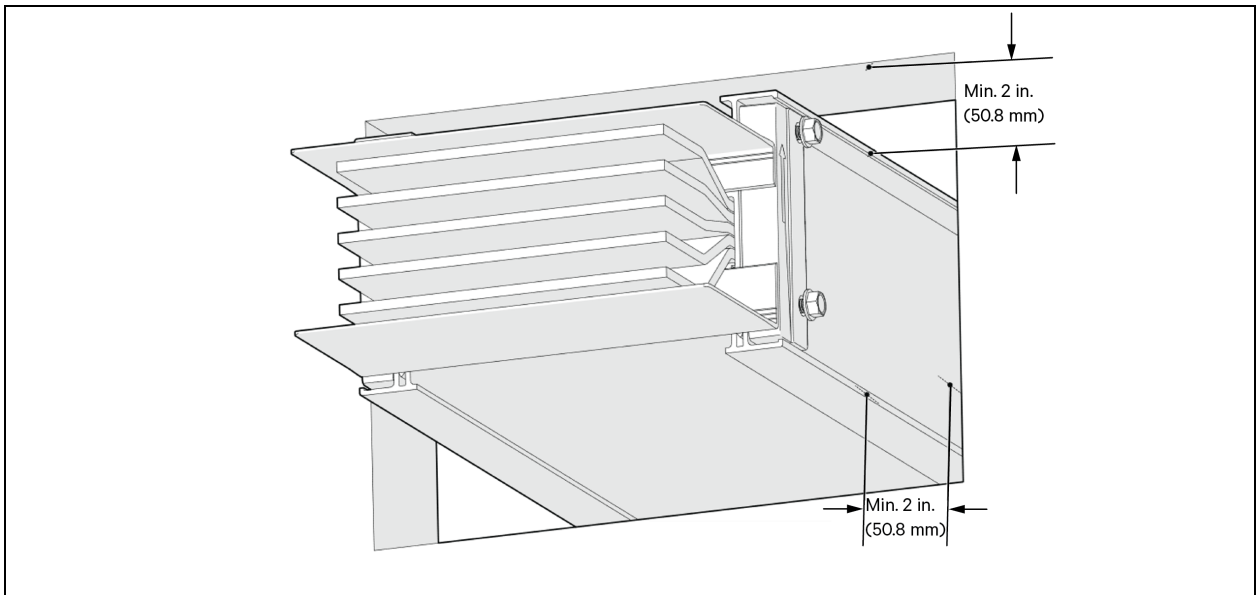

A minimum of 2 in. of clearance is required on all sides of the busway for wall penetrations.

5.6.2 Fire Barriers

When installing a busway section with a fire barrier, ensure that the fire barrier protrudes 2 in. (50 mm) to 4 in. (100 mm) from both sides of the wall. The final sealing between a fire barrier and a wall is to be completed by site builder, NEC and local regulations are followed.

Figure 5.12 Fire Barriers

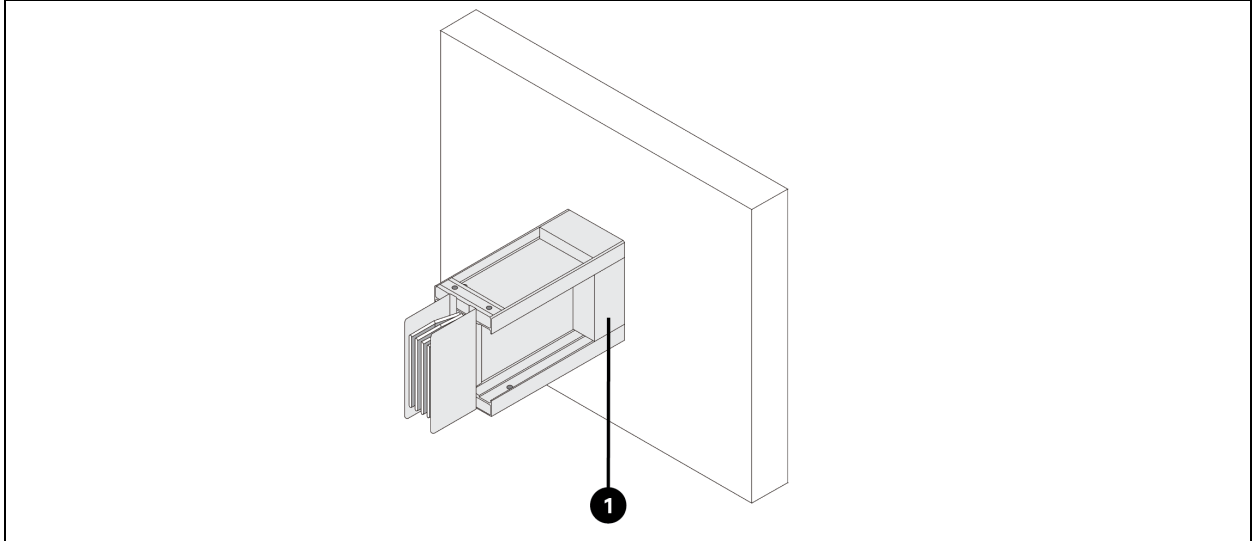

Item	Description
1	Fire barrier

Fire barrier must protrude at least 2 in. and no more than 4 in. Fire barrier is factory installed to the busway section designed to penetrate a fire wall. Adherence to installation plans is paramount to ensure busway fire barrier aligns with the penetration extending a minimum of 2 in. from the surface of firewall. Additional fire barrier to enclose the wall penetration is responsibility of others.

Figure 5.13 Fire Barrier Orientation

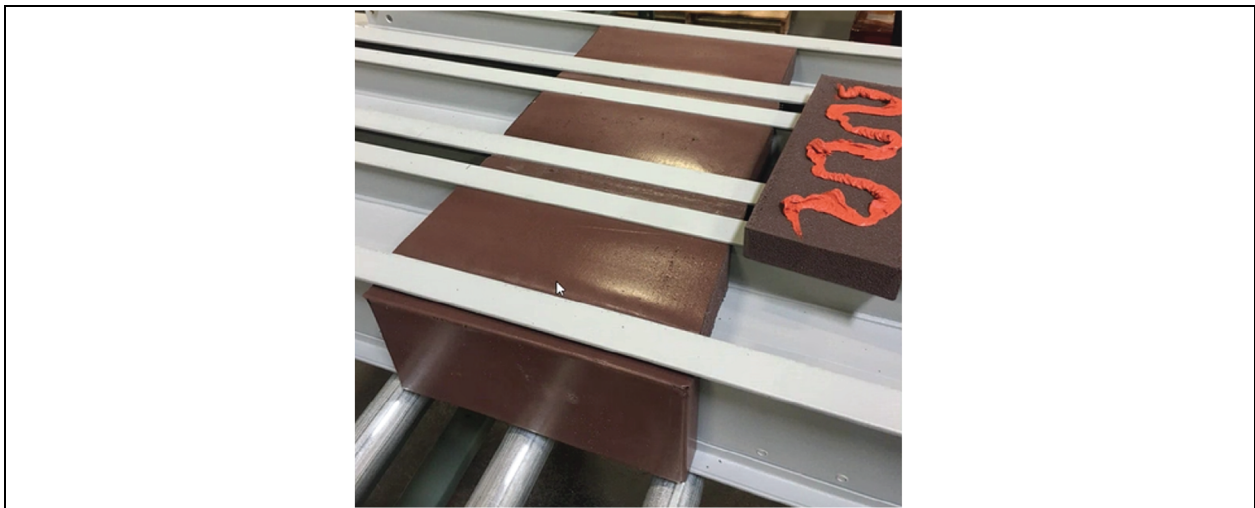

Figure 5.14 Fire Block



Indoor settings require minimum 8 in. (203 mm) of clearance from joint pack to wall. See **Figure 5.15** below.

Figure 5.15 Minimum Clearance of Joint Pack Cover

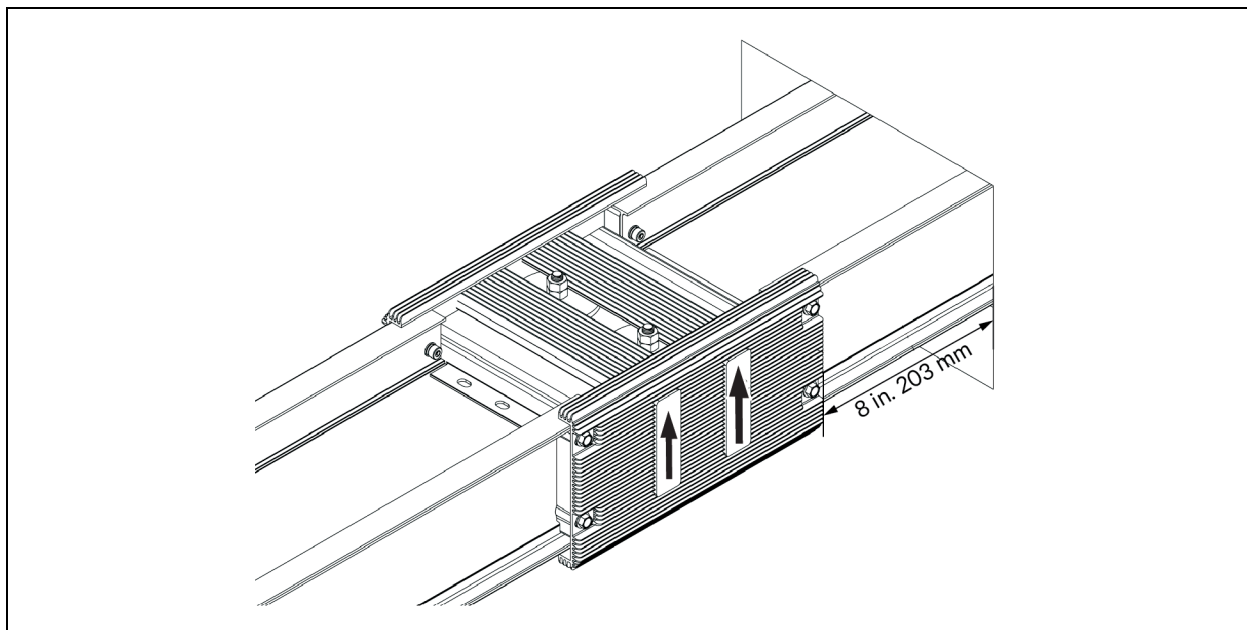
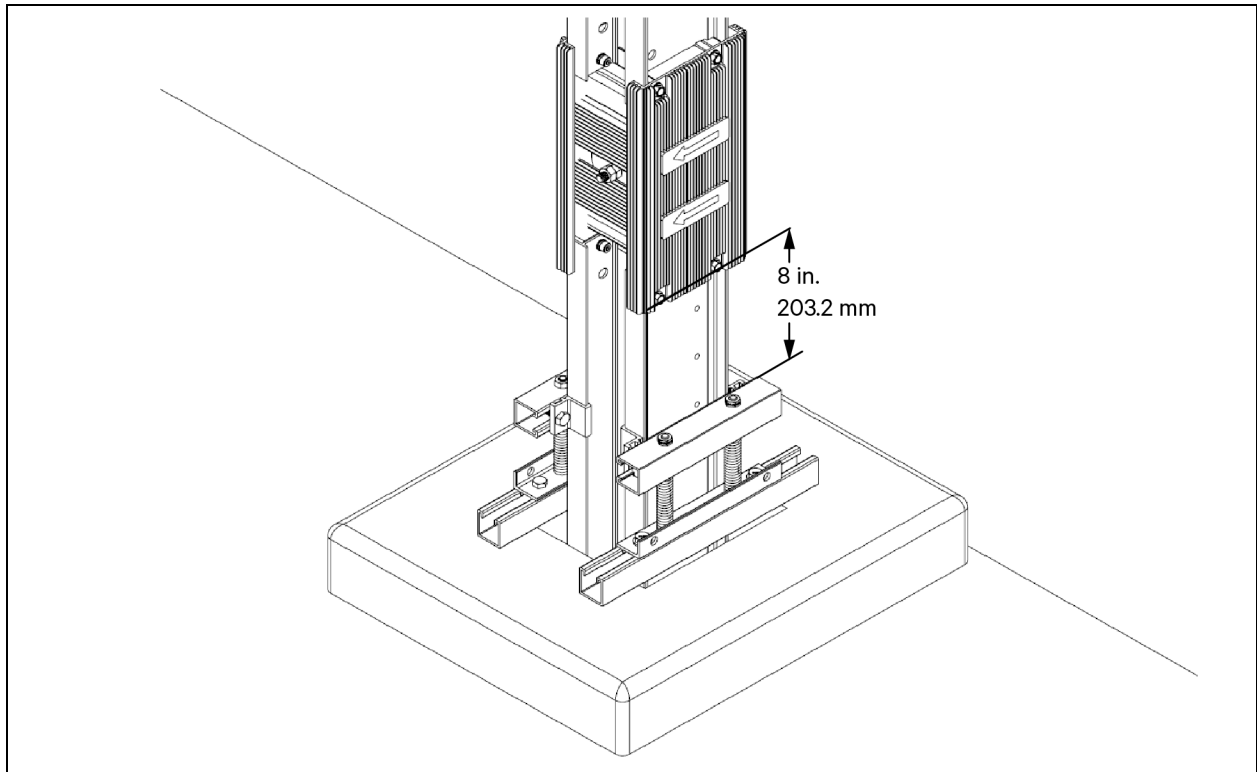

Figure 5.16 Minimum Clearance of Joint Pack Cover in Floor Penetrations

Minimum 8 in. (203.2 mm) from spring hanger bracket to bottom of joint pack in vertical mounting/floor penetrations.
Minimum 12 in. (304.8 mm) to concrete from bottom of joint pack cover.

5.7 Mounting Methods

5.7.1 Horizontal Orientation

The busway sections are secured to a framing system, such as strut channel, using the fixing brackets. The bar can be secured both on its flat and on its edge. When installed in flatwise orientation the busway must always have neutral on top.

Figure 5.17 Horizontal Flatwise

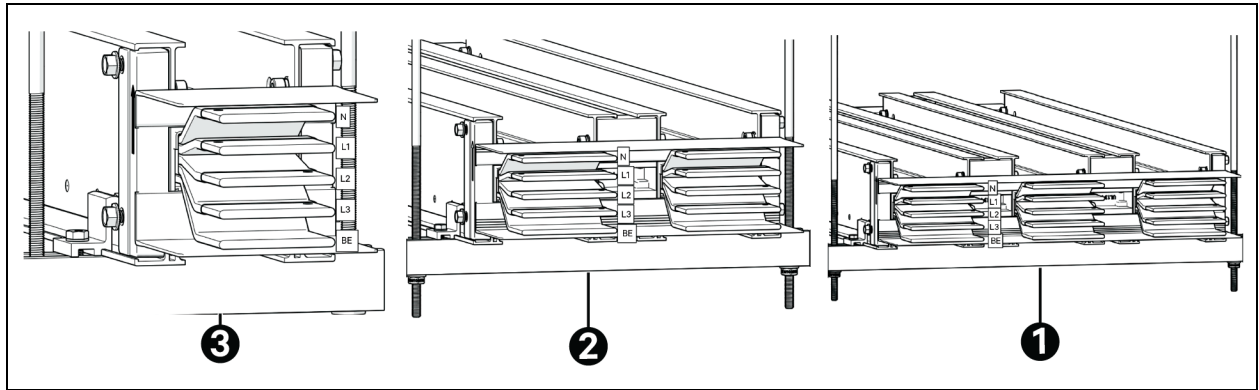

Item	Description
1	Triple body
2	Double body
3	Single body

Figure 5.18 Horizontal Edgewise

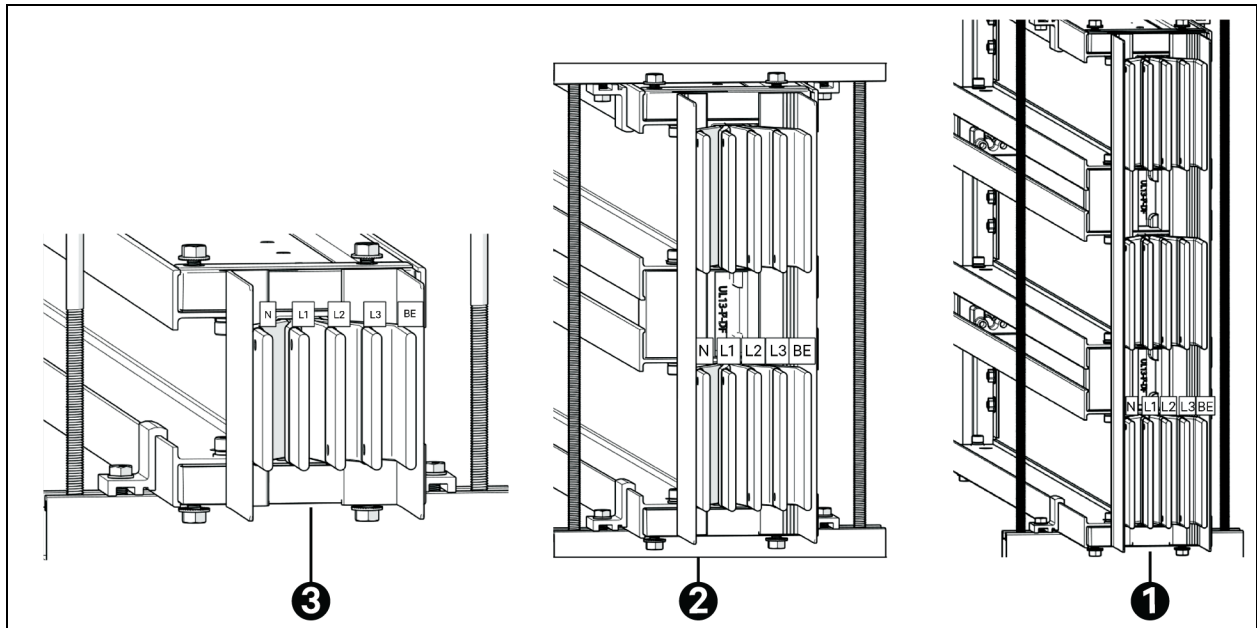

Item	Description
1	Triple body
2	Double body
3	Single body

Components: Hanging brackets/strut channel and drop rods (provided by others).

NOTE: Vertiv does not provide hardware for installation.

This page intentionally left blank

6 Installation

6.1 Hanging Busway

6.1.1 Horizontal Hanging

Vertiv recommends that the fixing brackets for the Vertiv™ High PowerBar (HPB) UL 857 must be mounted with support no more than 2.5 ft (762 mm) from the center of each bus joint and with no more than 5 ft (1524 mm) between supports. Tighten the fixing brackets to 10 Nm (7.4 ft-lbs). Additional hangers may be used depending on site specific requirements.

Vertiv™ High PowerBar (HPB) UL 857 must be supported by fixing brackets and supports:

1. Within 2.5 ft (762 mm) from the center of each bus joint.
2. Separation between busway supports does not exceed 5 ft (1524 mm).

Figure 6.1 Maximum Distance of Busway Supports from Center of Joint Pack

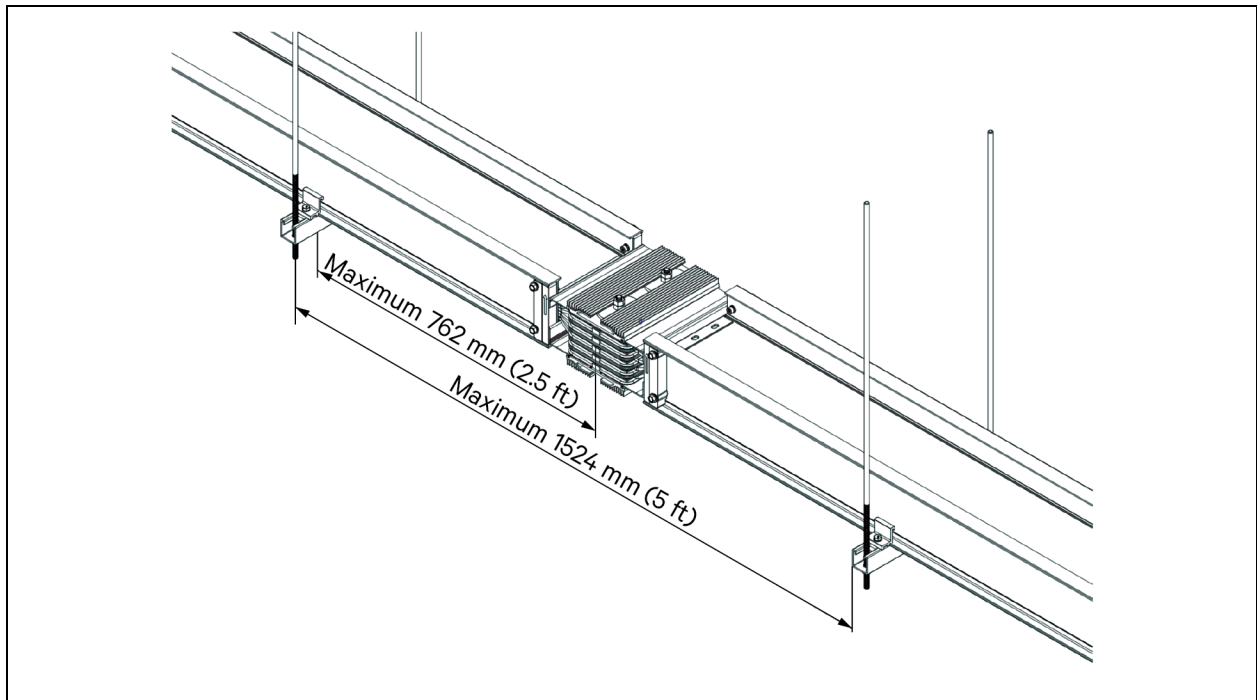

Maximum distance of busway supports from center of joint pack is 762 mm (2.5 ft). Maximum distance between busway supports on either side of joint is 1524 mm (5 ft).

Figure 6.2 Maximum Distance between Busway Supports

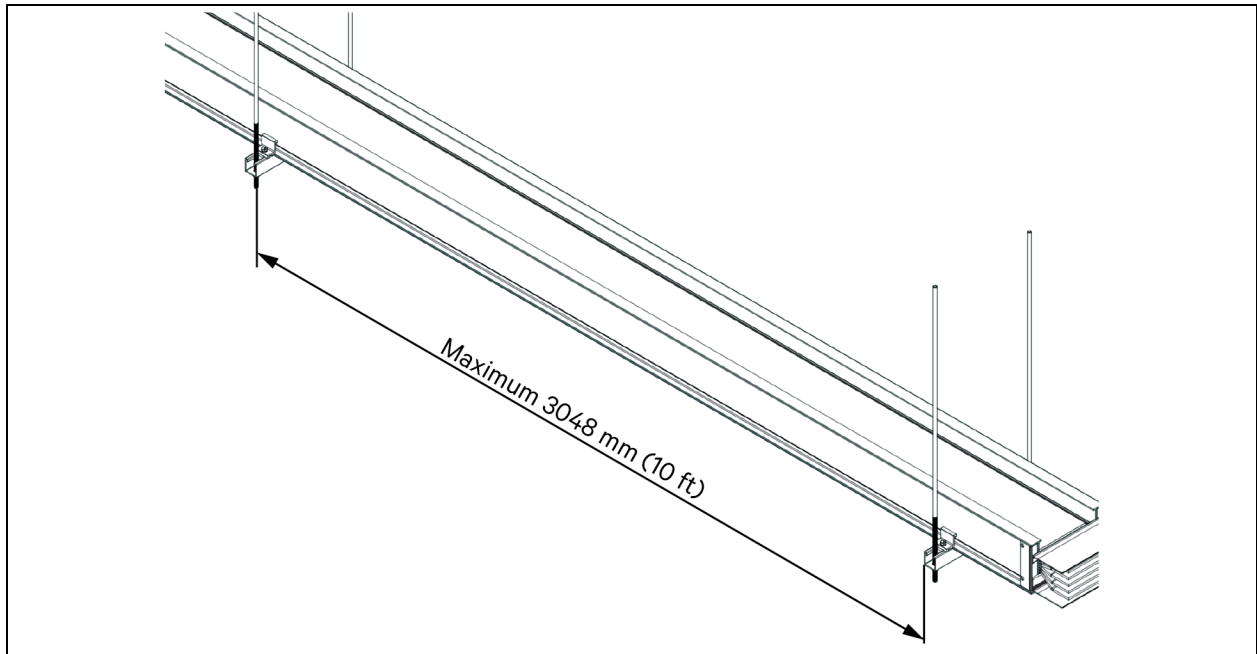

Maximum spacing of fixing brackets and supports is 3048 mm (10 ft).

NOTE: It is the responsibility of the support system supplier to ensure their system can safely support the weight of our product.



CAUTION: Vertiv™ High PowerBar (HPB) UL 857 fixing brackets must be used. Drilling or cutting the busway on site is prohibited. If threaded rod length exceeds more than 8.2 ft. (2500 mm), there must be a rigid support every 20 ft (6096 mm).

6.1.2 Vertical Hanging

On a vertical riser the fixing brackets should be no more than 5 ft (1524 mm) apart, each bar is required to be fixed at two positions, and the torque value of the fixing bracket must be increased to 25 Nm (19 ft-lbs).

1. Fix solid strut channel of size 1 5/8 in. x 1 5/8 in. (41 mm x 41 mm) on floor or wall as per layout drawing.
2. Lower busway into place and connect to joint pack. Ensure the weight of the busway is supported throughout. Only hand tighten joint pack at this stage.
3. Attach spring hanger brackets to strut channel with M10 hex bolt and lock nut, tighten the bolts to 47.5 Nm \pm 4 Nm (35 ft-lbs \pm 3 ft-lbs).
4. Attach spring hanger brackets to busway using fixing brackets.

Figure 6.3 Spring Hanger Alternate Installation After Busway is Installed

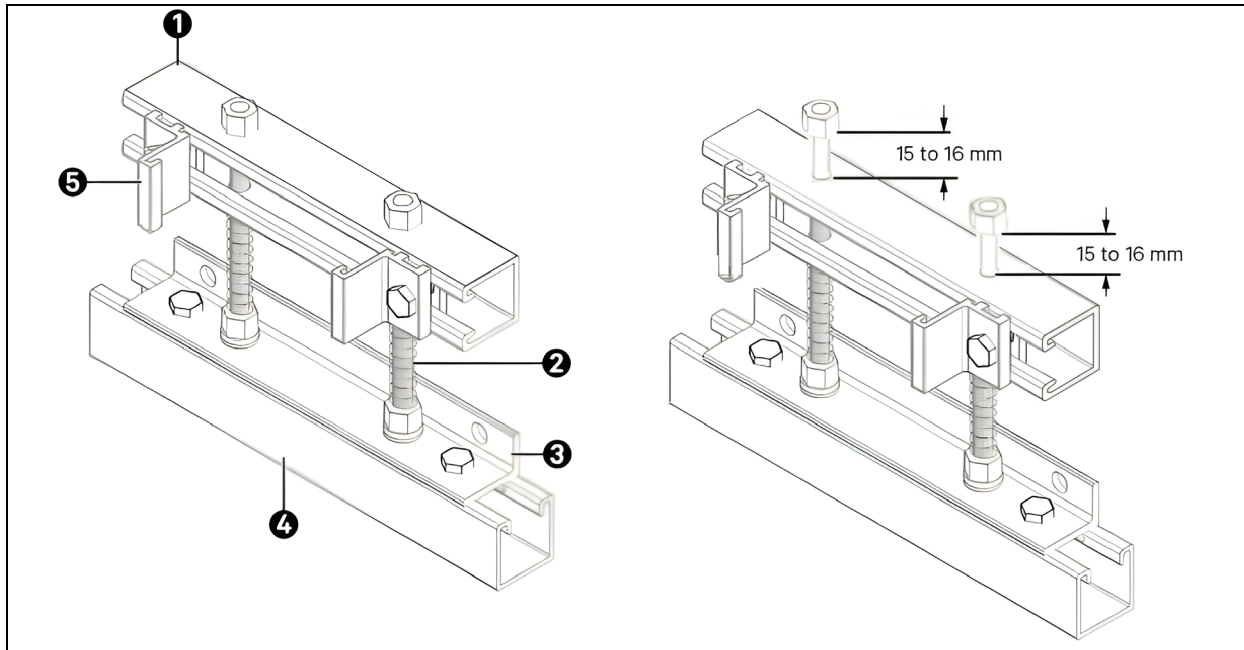

Item	Description
1	Unistrut
2	M10 x 150 mm bolt (fully threaded)
3	Support bar
4	Unistrut (not in PBG scope)
5	HPB fixing bracket

Spring Hanger Alternate Installation After Busway is Installed:

- Loosen 2 no. fixer brackets on one spring hanger.
- Tighten 2 no. M10 nylock nuts 15 mm to 16 mm from tail of M10 screw.
- Tighten 2 no. fixer brackets to 25 Nm.
- Loosen 2 no. nylock nuts so 3 threads of the M10 screw are showing (since this nut is not under load, no need to torque mark).

6.2 Joining Busway Sections

NOTE: Tolerances will vary according to the standards used (UL Standard or UL13).

6.2.1 End to End Installation (Method A)

1. Ensure all components are properly and consistently oriented, with the joint block arrows pointing in the same direction on adjoining busway segments. (Refer to busway submittal drawing.)

Figure 6.4 Busway Orientation

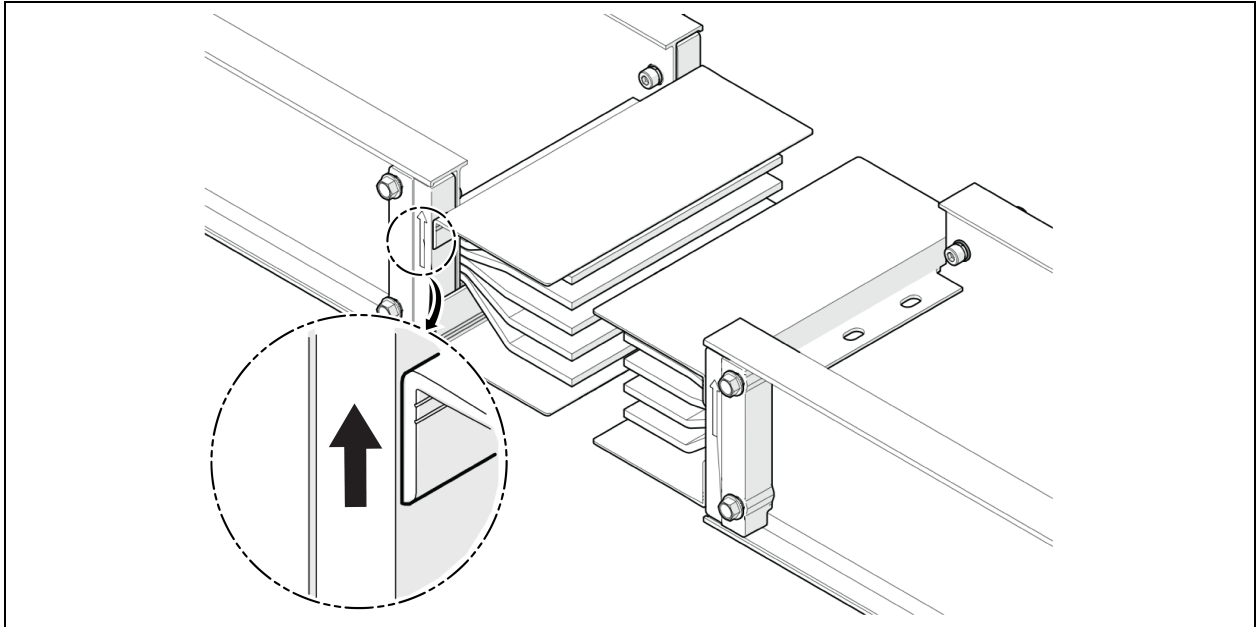

2. Mount Busway A firmly to the strut channel framing.
3. Ensure the busway is in alignment left to right and top to bottom. Busway needs to be leveled, straight, and plumb using proper tools, (string line, laser level, and so on) to the point that a joint pack can be installed without undue force.



CAUTION: Unlevel busway can increase the difficulty of joint installation.

4. Inspect the joint pack to ensure that all contacts are free of contaminants, unblemished, undamaged, and correctly aligned.
5. Loosen the joint pack nuts sufficiently to splay the joint pack but not so much that it disengages the assembled parts. See **Figure 6.5** on the facing page.



CAUTION: Clamping nut and jam nut should never be removed from the clamping bolt. Nuts should always be fully engaged with the bolt threads.

Figure 6.5 Splaying Joint Pack

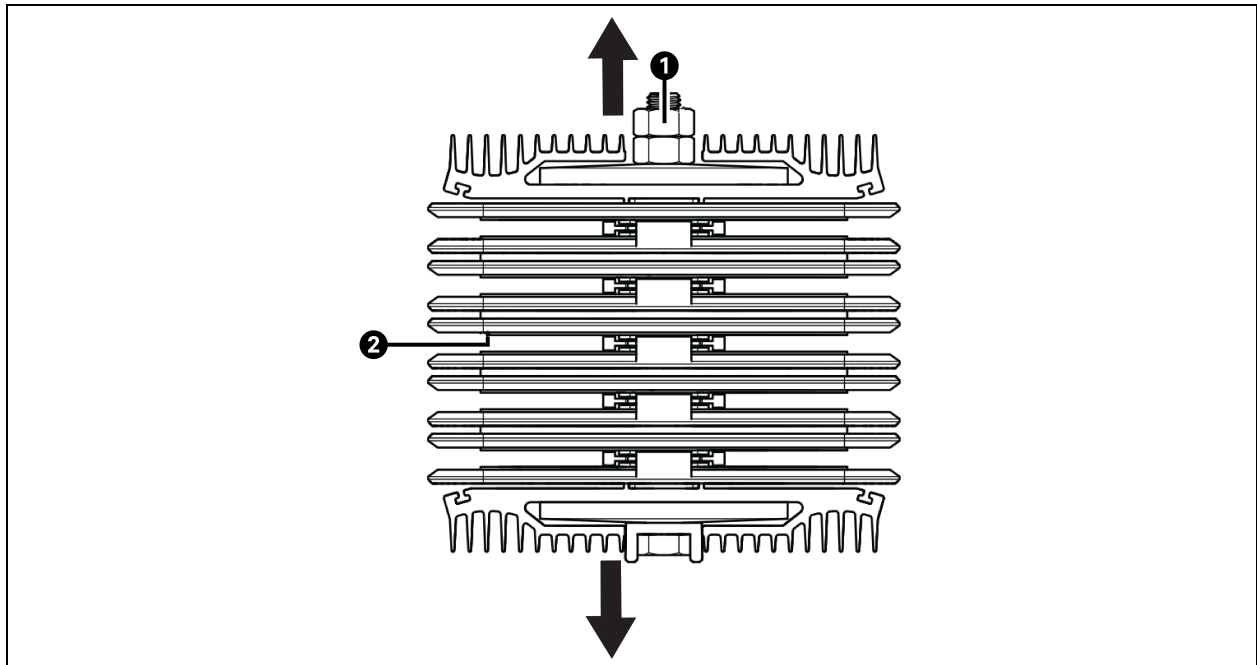

Item	Description
1	Loosen NOTE: Do not remove.
2	Spread plates to facilitate installation

6. Insert plastic combs into the Busway side of the joint pack, the fingers of the comb must be inserted between the joint pack connector plates. See **Figure 6.6** below and **Figure 6.7** on the next page.

Figure 6.6 Inserting Joint Pack Guide Comb

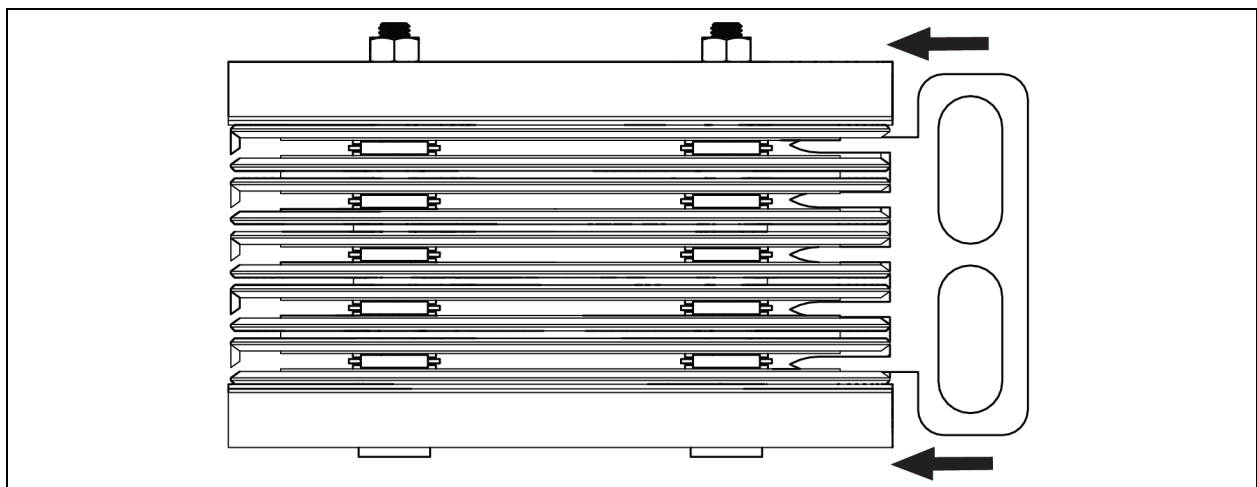
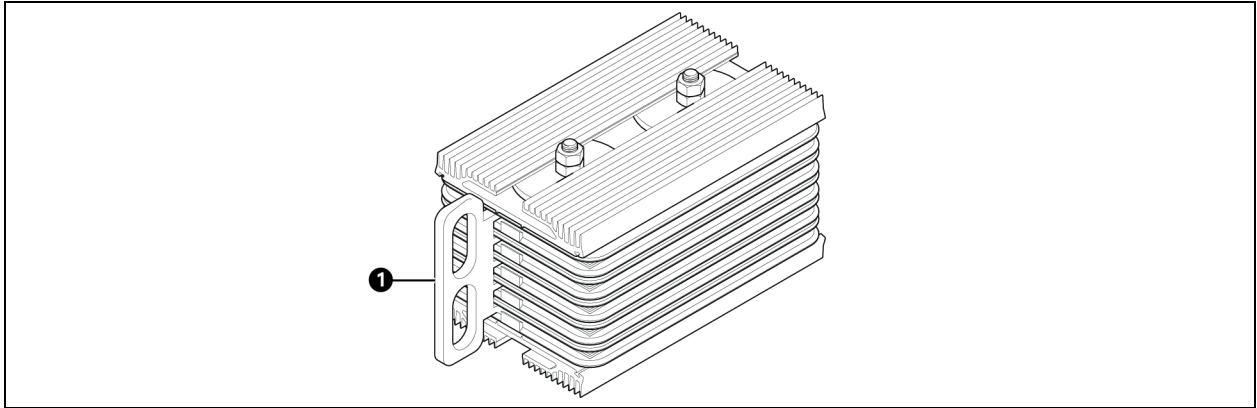

Figure 6.7 Inserting Joint Pack Guide Comb



Item	Description
1	Plastic comb

NOTE: Plastic combs are provided with 5 fingers, fingers can be removed to match busway configuration, see **Figure 6.8** below.

Figure 6.8 Modifying Guide Comb Based on Busway Configuration

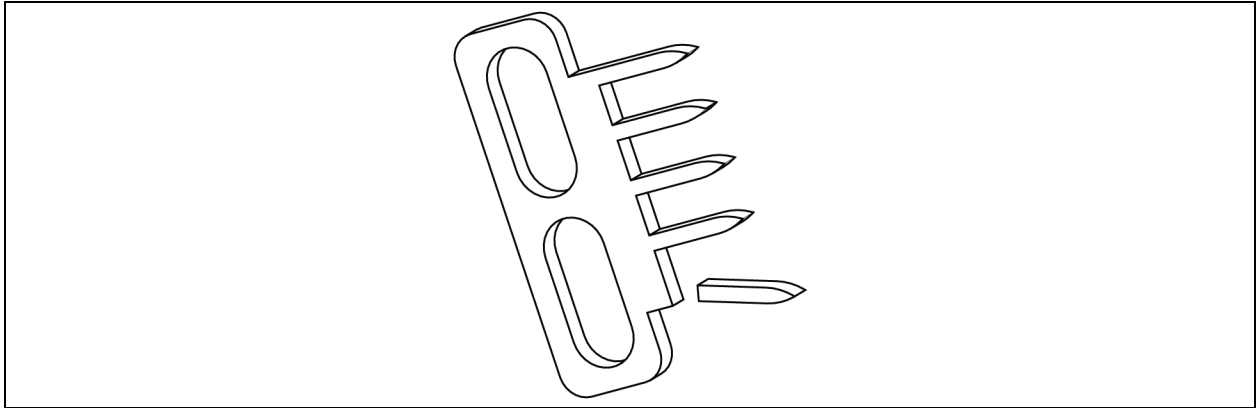

7. Place the Spacer Block onto Busway A as shown in **Figure 6.9** on the facing page. Ensure orientation is as shown to provide proper spacing.

NOTE: Ensure Spacer Blocks are oriented correctly as shown to give proper joint spacing.

Figure 6.9 Placing Joint Spacer Block on Busway A

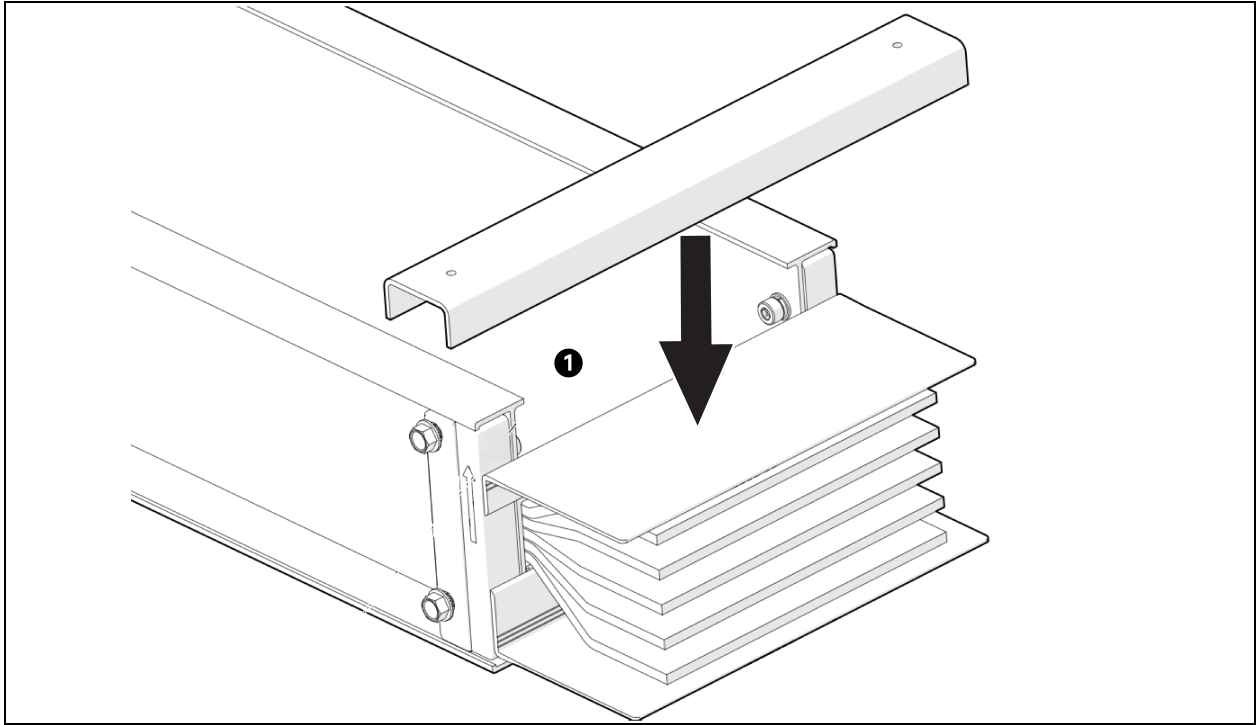

Item	Description
1	Spacer block

8. Insert joint pack into Busway A up to the spacer block. Ensure all busbars and ground flanges are correctly aligned with the joint pack connector plates. Complete insertion to the spacer block is not required at this time.

NOTE: The Joint Pack includes gaskets. Care must be taken when installing to avoid damaging or dislodging of the gaskets. Example of partially dislodged gasket can be seen in Figure 6.10 below.

Figure 6.10 Example of Partially Dislodged Gasket



NOTE: Start joint pack on one corner on the side where the comb is located. Ensure all bus bars are aligned in the correct segments of the joint pack. Once the bus bars are aligned with the joint pack, remove the comb tool, and rotate and press the joint pack into place.

9. Align the busway and joint pack using straight edge, level on all sides.
10. Insert plastic combs into the joint pack from the Busway B side, inserting fingers of the comb between the joint pack connector plates. See **Figure 6.6** on page 27 and **Figure 6.7** on page 28.
11. Insert the aligned Busway B partially into the joint pack. Once bus bars are started into joint plates, remove spacer comb tools from joint pack.
12. Position the Installer Provided compression clamps on each side of the busway housing at the joint blocks.

NOTE: Be careful with overcompressing the joint, the spacer blocks will be removed afterwards.

13. Align and place the spacer block on busway B **Figure 6.11** below.

NOTE: Ensure spacer blocks are oriented correctly with proper alignment.

Figure 6.11 Placing Spacer Block onto Busway B

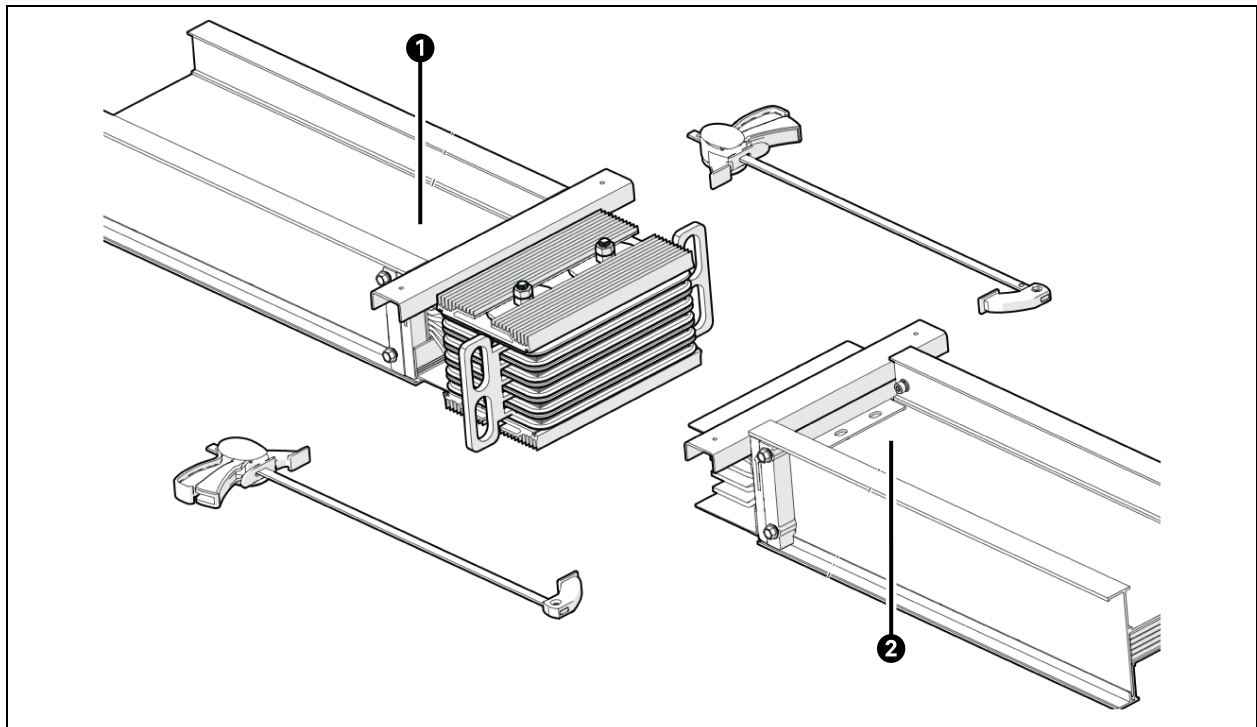

Item	Description
1	Busway A
2	Busway B

14. Ensure all spacer comb tools are removed. Ensure bus sections are level and aligned, then apply compression tools. Tighten the compression clamps uniformly (one on each side of the busway joint) to bring Busway A and B together until the outer plate of the joint pack makes contact with the spacer blocks.

Figure 6.12 Applying Clamps to Pull Busways into Joint Pack

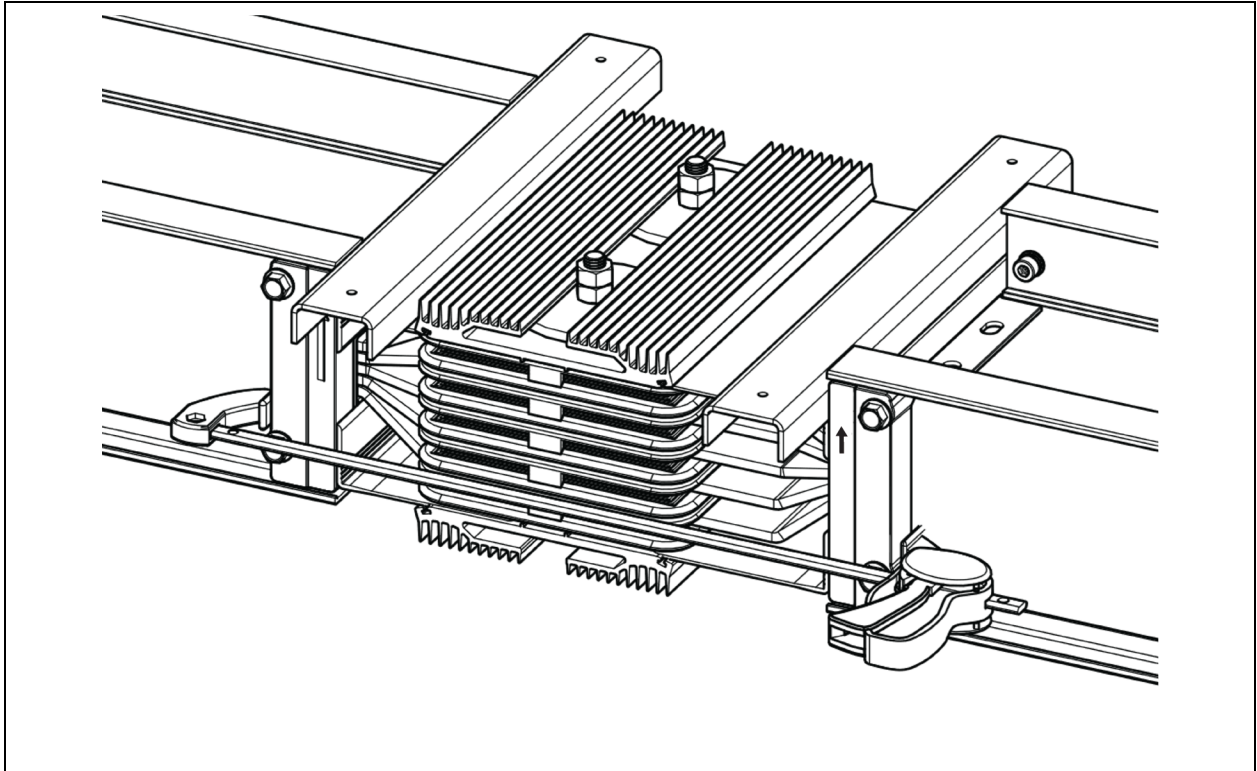

15. Inspect Joint Pack and busway sections for proper alignment of all components. Ensure plastic tabs on sides of Joint Pack are not broken due to shipping or mishandling

NOTE: The installer can initially tighten the joint pack primary nut 10 NM (14.8 ft-lbs) allowing for adjustment and alignment of the joint. Do not fully tighten joint pack at this time.

16. Verify the distance from Busway A to Busway B as shown in **Figure 6.13** on the next page.

NOTE: Tolerances vary based on UL Standard or UL13 components.

Figure 6.13 UL Standard and UL13 Busway to Busway Distance

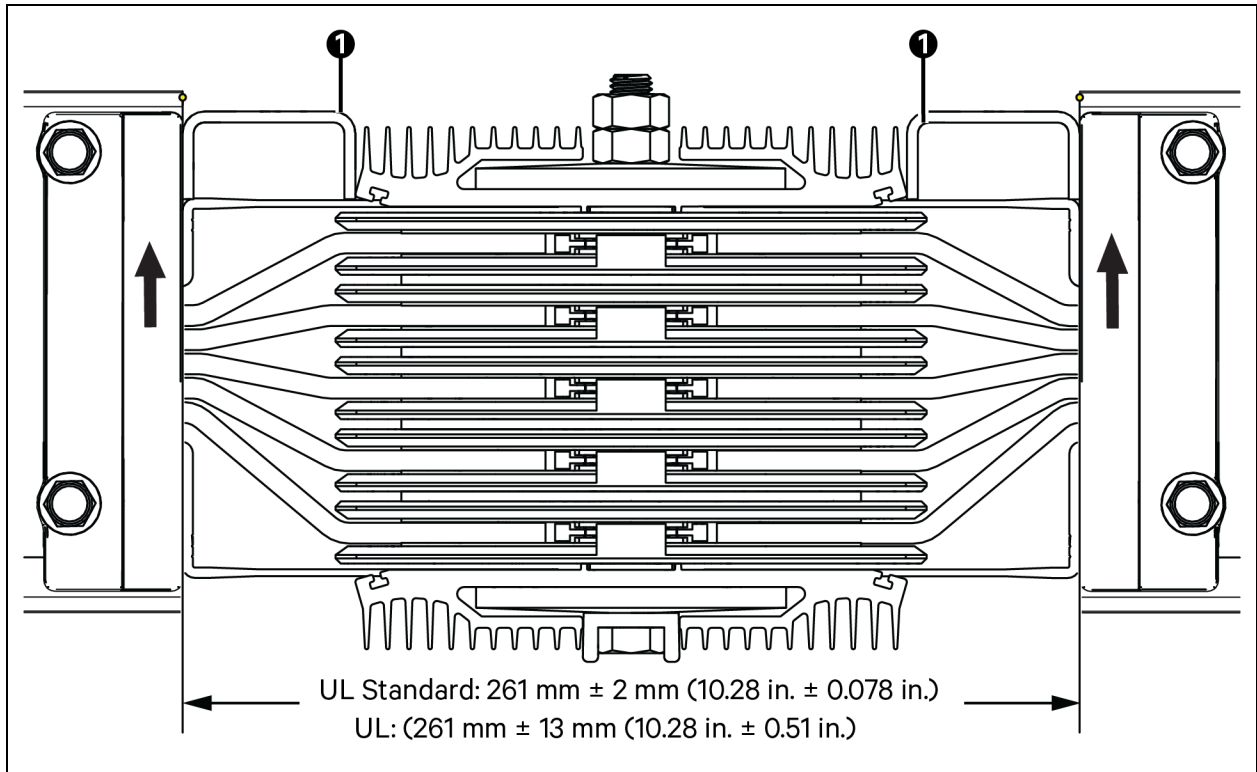

Item	Description
1	HPB-JPJ-0001

NOTE: For UL13 joints, ensure the space for the spacer blocks does not vary by more than 3mm and the ESP fins do not ride up under the JSP nibs.

NOTE: HPB busway joints require a minimum of 12 mm electrical contact between each busbar and the joint connectors.

17. Make sure busway and joint pack is aligned using straight edge level on all sides. Remove joint spacer blocks.



CAUTION: To avoid damage to the Joint Pack, do not apply pressure to the plastic insulators. Ensure plastic tabs on side of joint pack are undamaged, shown in **Figure 6.15** on the facing page.

18. Ensure that the ESP plates do not pass the JSP plate nibs when inserted as shown in **Figure 6.14** on the facing page.

Figure 6.14 ESP plate JSP plate



Item	Description
1	Location of ESP plate and JSP plate

Figure 6.15 Ensure Plastic Tabs on Joint Pack are not Broken

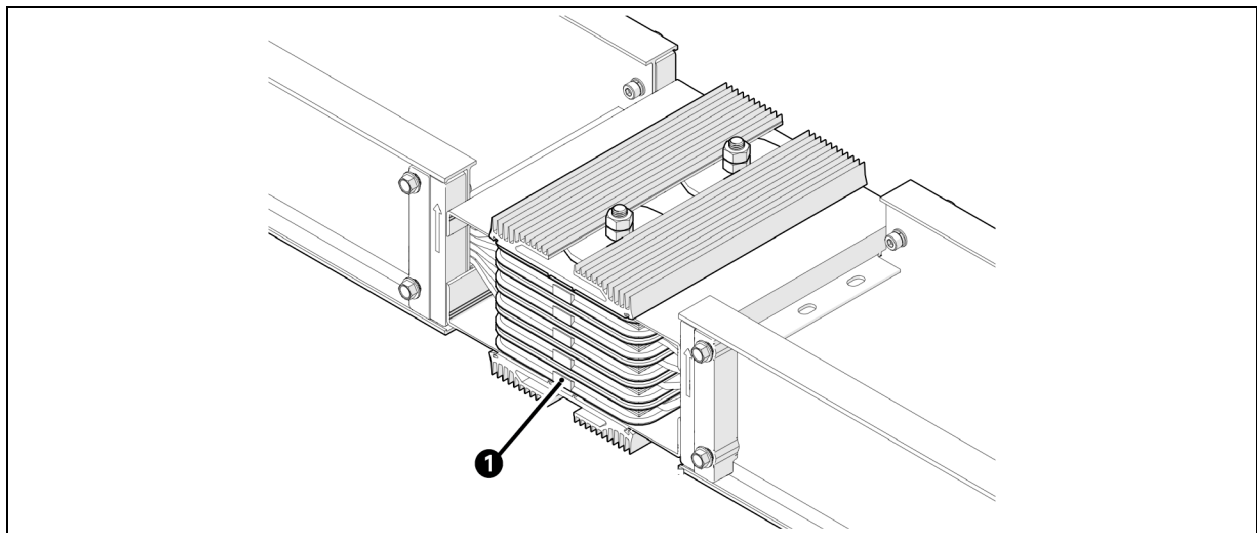

Item	Description
1	Ensure plastic tabs on sides are not broken

19. Fit the joint covers to each side of the joint pack. Alternate tightening of the M8 fasteners to ensure joint cover is pulled into bus sections evenly and ensure the joint cover gaskets are flush with the joint blocks. Tighten the M8 fasteners to a seated torque of 10 Nm (7.4 ft-lbs).

NOTE: DO NOT exceed 15 Nm (11 ft-lbs) of driving torque.

NOTE: A M8 T handle ball end hex wrench can be used to assist alignment and fit of the joint cover to the busway before fastening.

NOTE: It is important that the M12 joint bolts are sufficiently tightened (not torqued at this step) to ensure the joint pack does not move out of alignment prior to tightening joint cover bolts.



CAUTION: To avoid stripping Joint Block threaded inserts, hand start the joint cover screws before using a hand driver or torque wrench.

NOTE: Installation tools can be provided to ease alignment and installation of busway.

20. Tighten the first M12 nuts to $90 \text{ Nm} \pm 4 \text{ Nm}$ ($67 \text{ ft-lbs} \pm 3 \text{ ft-lbs}$) using a calibrated torque wrench with a 19 mm deep-well socket. Tighten the second lock nut over the first to $70 \text{ Nm} \pm 4 \text{ Nm}$ ($52 \text{ ft-lbs} \pm 3 \text{ ft-lbs}$).

NOTE: If joint pack contains multiple joint bolts, tighten using an alternating pattern to avoid distortion of the joint pack and busway.

NOTE: The primary and secondary nuts can be driven at the same time, ensuring there is a two thread separation between nuts. Once the primary bottoms out and is torqued to 90 Nm, then the secondary nut can be tightened to 70 Nm.



CAUTION: Prior to energization, perform a visual inspection of the joint connection to ensure all components are aligned and to recheck spacing between busways 10.28 in. (261 mm) **Figure 6.16** on the facing page.

Figure 6.16 Assembled Joint Pack

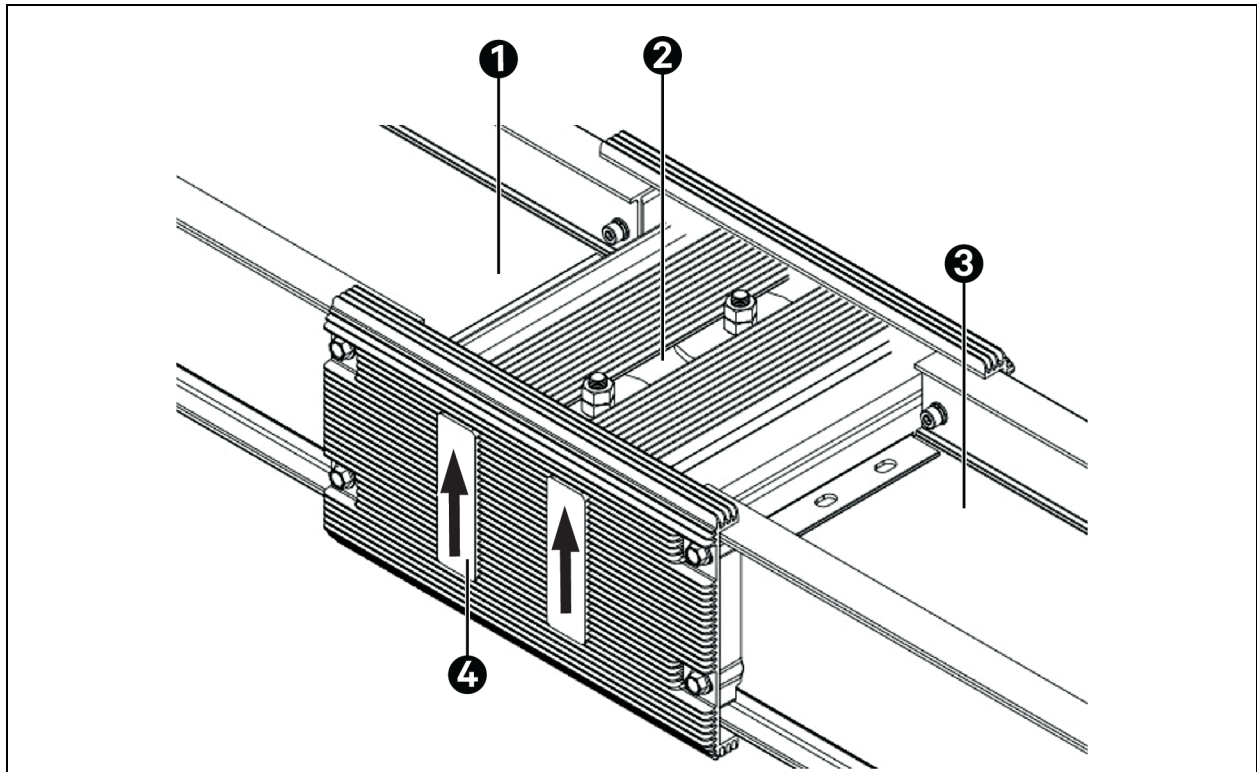

Item	Description
1	Busbar A
2	Joint
3	Busbar B
4	Joint cover

6.2.2 Side Installation (Method B)

1. Repeat [step 1](#) through [step 5](#) from [End to End Installation \(Method A\)](#) on page 26.
2. Use the Joint Pack pusher plate HPB-00000-00569 on the opposite side of the joint pack. The Pusher Plate sets proper alignment and spacing between busway sections. See [Figure 6.17](#) on the next page.

Figure 6.17 HPB-00000-00569 Plate Applied to Busways

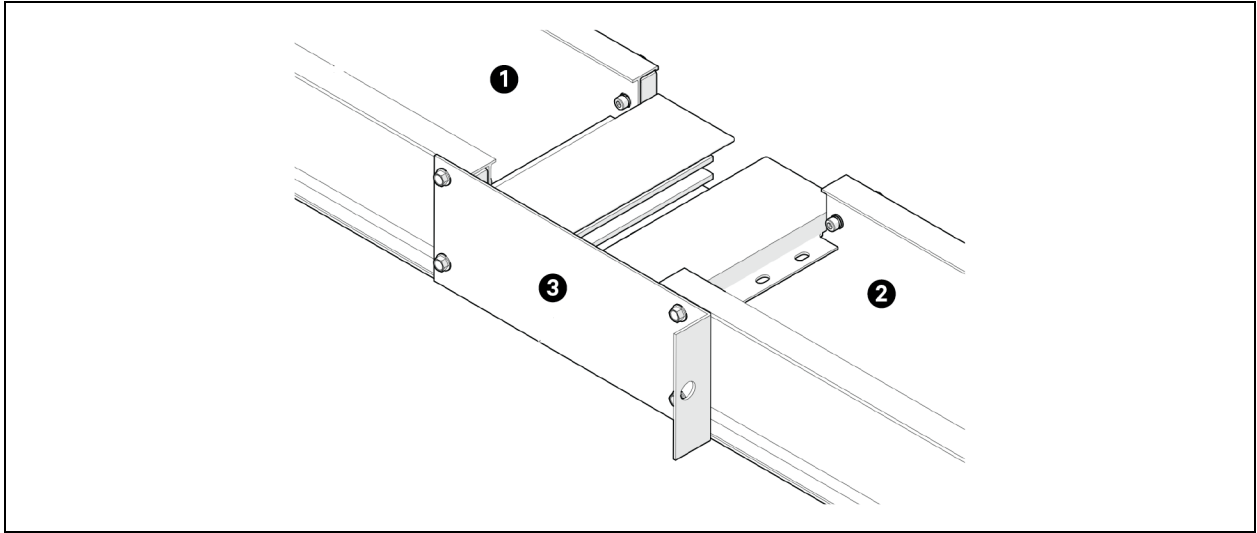

Item	Description
1	Busway B
2	Busway A
3	Joint pack pusher plate 1 (HPB-00000-00569)

3. Verify the spacing between busway A and B as shown in Figure 6.18 below.

NOTE: Varying tolerances based on UL Standard or UL13 components.

Figure 6.18 UL Standard and UL13 Busway to Busway Distance

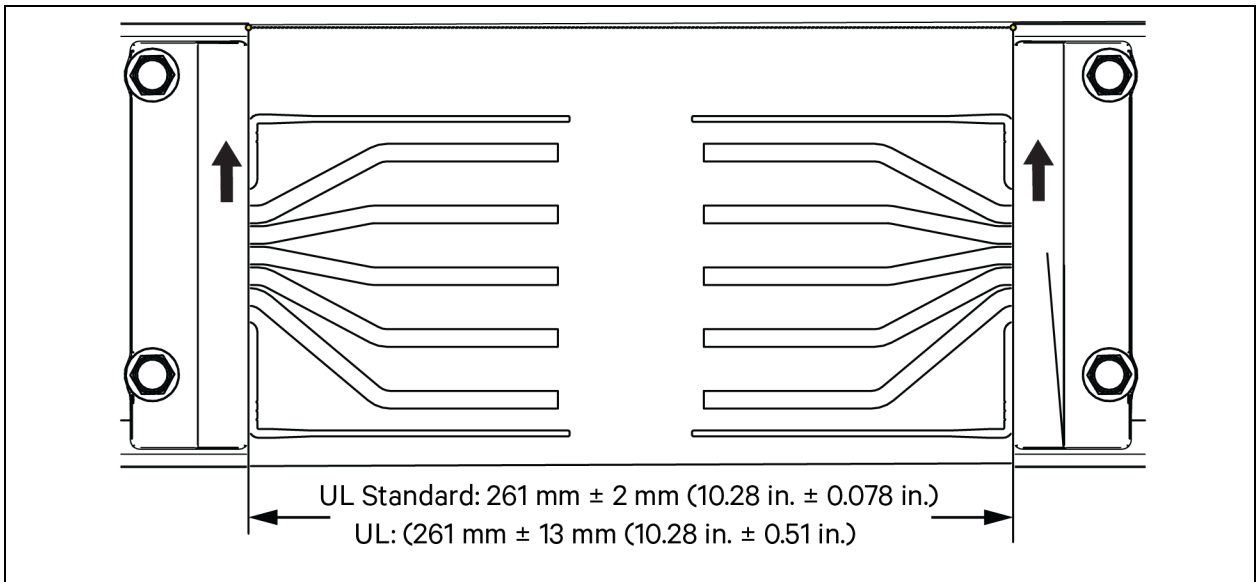

4. Place the spacer blocks on busway A and B as shown in Figure 6.19 on the facing page.

Figure 6.19 Placing Spacer Blocks on Busways

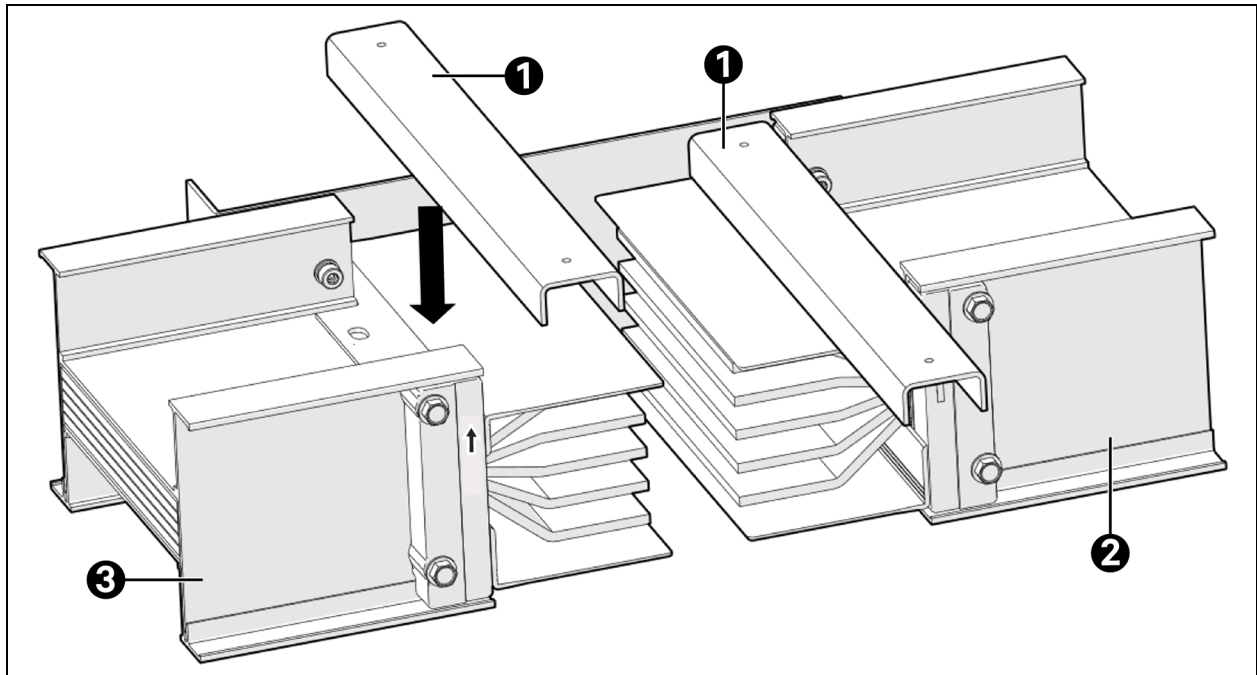

Item	Description
1	Spacer block (HPB-JPJ-0001)
2	Busway B
3	Busway A

5. Insert guide combs into joint pack, align Joint Pack between spacer blocks, and insert into the space between the Busway Sections, ensuring busway conductors fit between joint pack conductor plates. See **Figure 6.20** on the next page.

Figure 6.20 Orienting Joint Pack to Busway

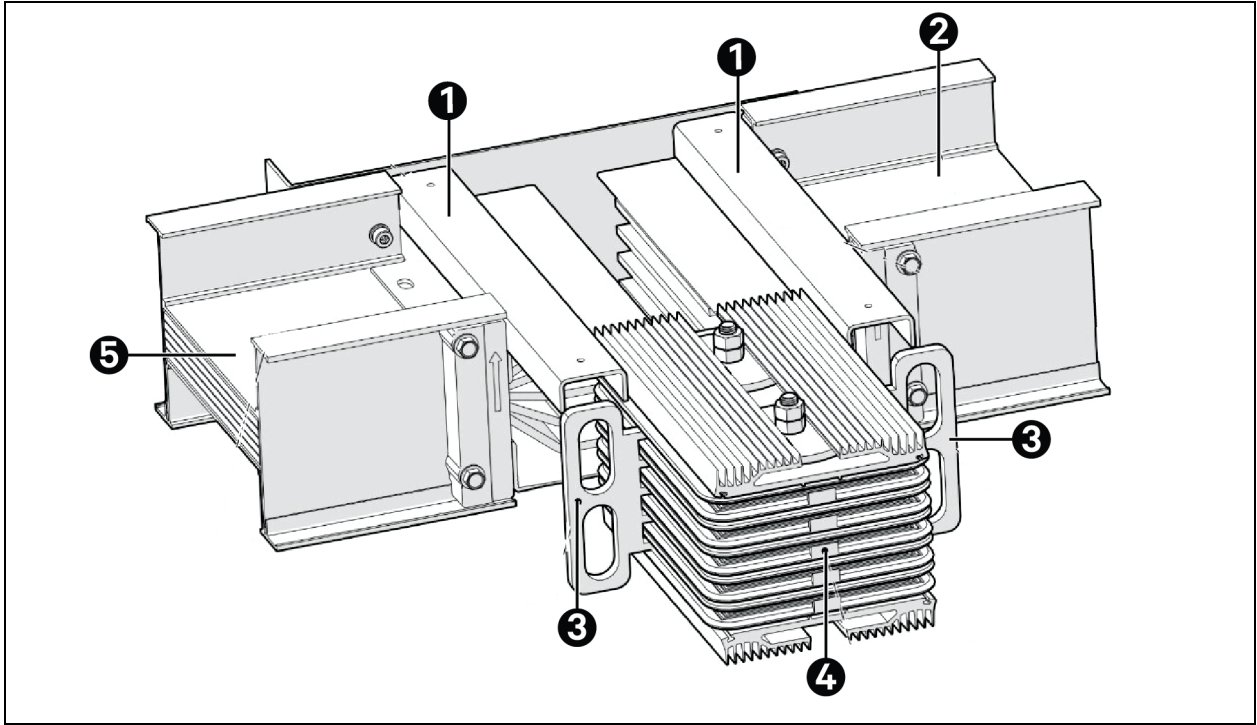

Item	Description
1	Spacer block (HPB-JPJ-0001)
2	Busway B
3	Guide comb
4	Joint pack
5	Busway A

- Securely place HPB-00000-00568 pusher plate over the outer end of the joint pack. See **Figure 6.21** on the facing page.

Figure 6.21 Placing HPB-00000-00568 Pusher Plate and Applying Clamps

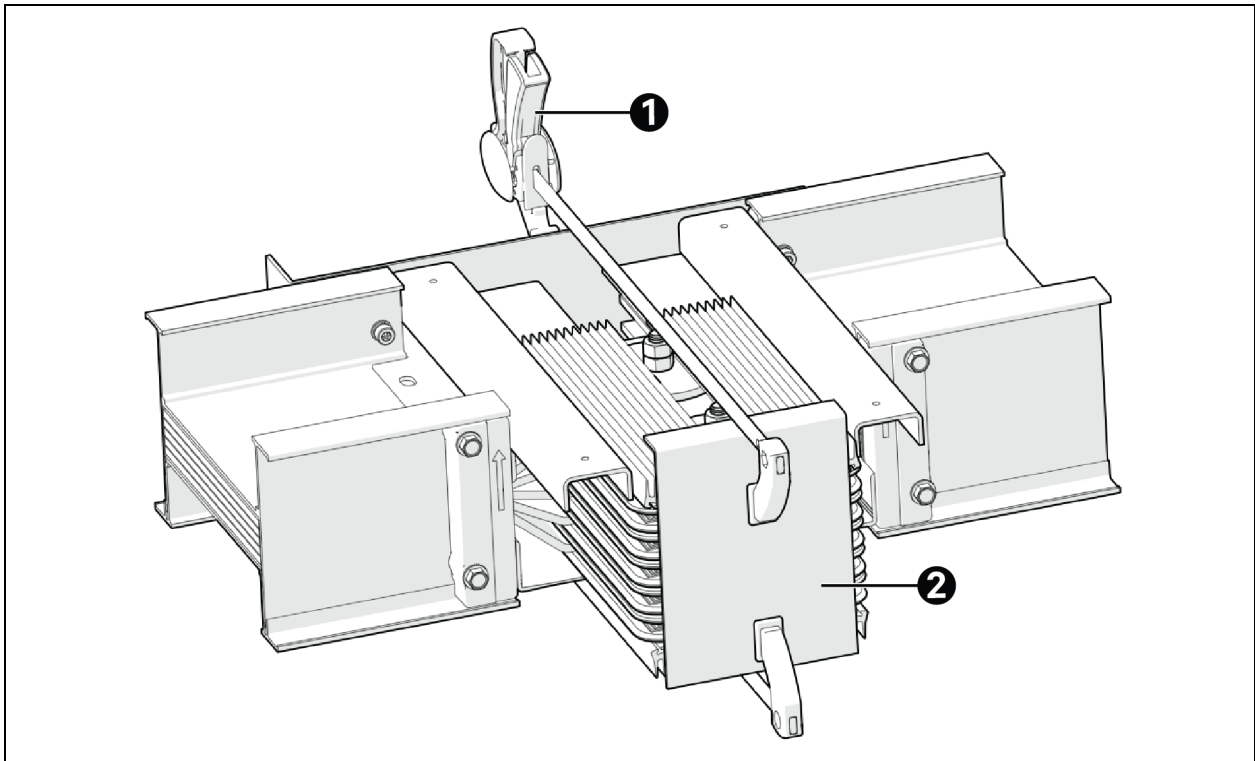

Item	Description
1	600 lb Clamp (Length depends on busway width)
2	Pusher plate 2 (HPB-00000-00568)

7. Position the installer provided compression clamps as shown **Figure 6.22** on the next page.

Figure 6.22 Applying Clamps to Both Pusher Plates

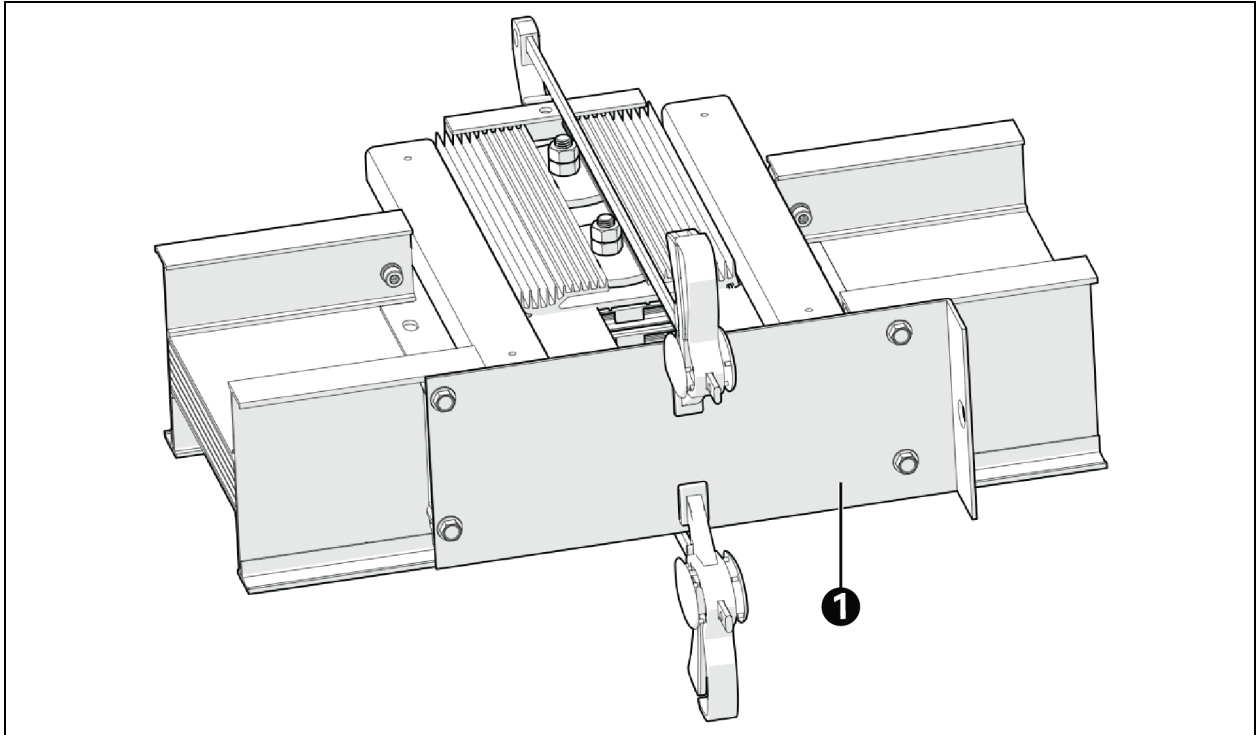

Item	Description
1	Pusher plate 1 (HPB-00000-00569)

8. Tighten the compression clamps uniformly to bring the Joint Pack fully installed between Busway A and B.

NOTE: Spacer blocks guides and center the joint pack between busway A and B.

9. Check and inspect joint pack for correct alignment of components.
10. Make sure busway and Joint Pack are aligned using straight edge level on all sides.



CAUTION: Do not apply pressure to the plastic insulators to avoid damage to the joint pack.

NOTE: Installation tools can be provided to ease alignment and installation of busway.



CAUTION: To avoid stripping joint block threaded inserts, hand start the joint cover screws before using a hand driver or torque wrench. Do not use impact wrench on any HPB hardware.

11. Fit the joint covers to each side of the joint pack. Alternate tightening of the M8 fasteners to ensure joint cover is pulled into bus sections evenly and ensure the joint cover gaskets are flush with the joint blocks. Tighten the M8 fasteners to a seated torque of 10 Nm (7.4 ft-lbs).

NOTE: DO NOT exceed 15 Nm (11 ft-lbs) of driving torque.

NOTE: A M8 T handle ball end hex wrench can be used to assist alignment and fit of the joint cover to the busway before fastening.

NOTE: It is important that the M12 joint bolts are sufficiently tightened (not torqued at this step) to ensure the joint pack does not move out of alignment prior to tightening joint cover bolts.

12. First tighten the M12 nuts with a torque of $90 \text{ Nm} \pm 4 \text{ Nm}$ ($67 \text{ ft-lbs} \pm 3 \text{ ft-lbs}$) using a calibrated torque wrench and 0.74 in. (19 mm) socket. Tighten the second lock nut over the first to $70 \text{ Nm} \pm 4 \text{ Nm}$ ($52 \text{ ft-lbs} \pm 3 \text{ ft-lbs}$).

NOTE: If joint pack contains multiple joint bolts, tighten using an alternating pattern to avoid distortion of the joint pack and busway.

NOTE: The primary and secondary nuts can be driven at the same time, ensuring there is a two thread separation between nuts. Once the primary bottoms out and is torqued to 90 Nm, then the secondary nut can be tightened to 70 Nm.



CAUTION: Prior to energization, perform an inspection of the assembled joint connection to ensure all components are aligned and to recheck spacing between busways 10.28 in. (261 mm).

6.3 End Cap

1. Install plastic spacers over each phase bar, as shown in **Figure 6.23** below.



WARNING! Failure to install plastic spacers properly over phase bars may result in a failure resulting in extensive damage to the product and possible injury or death to workers.

Figure 6.23 Installation of Plastic Spacers

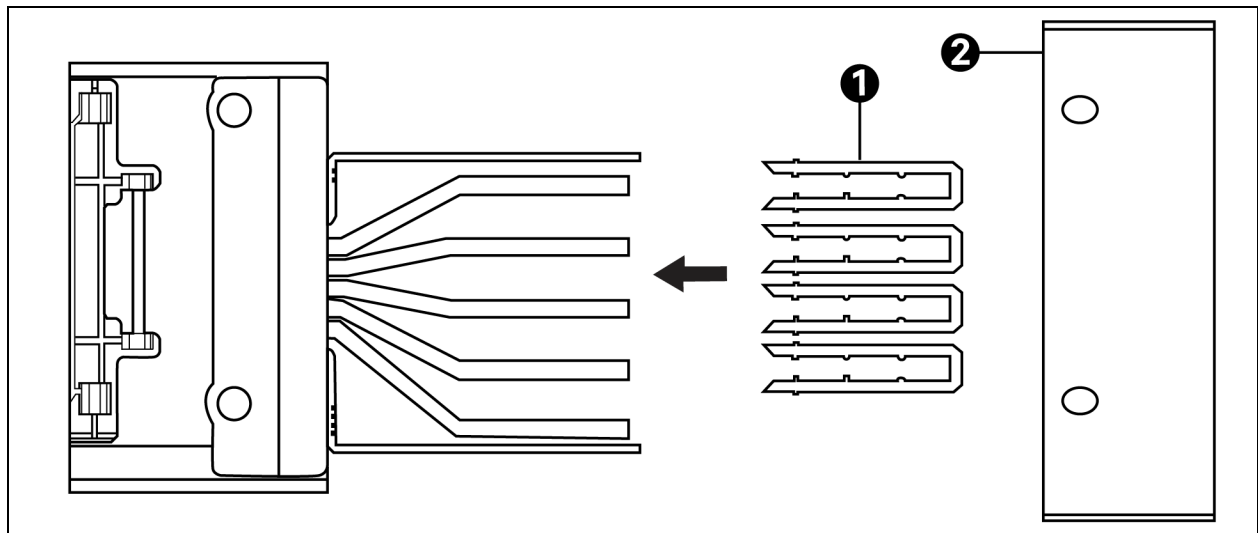

Item	Description
1	Plastic spacer
2	End cap

2. Flare open aluminum cover approximately ½ in. and affix onto end of busway as shown **Figure 6.24** below.

NOTE: Take care not to damage the gasket.

NOTE: Compression clamps can also be used to fit the end cap to the busway before fastening.

Figure 6.24 End Cap Installation

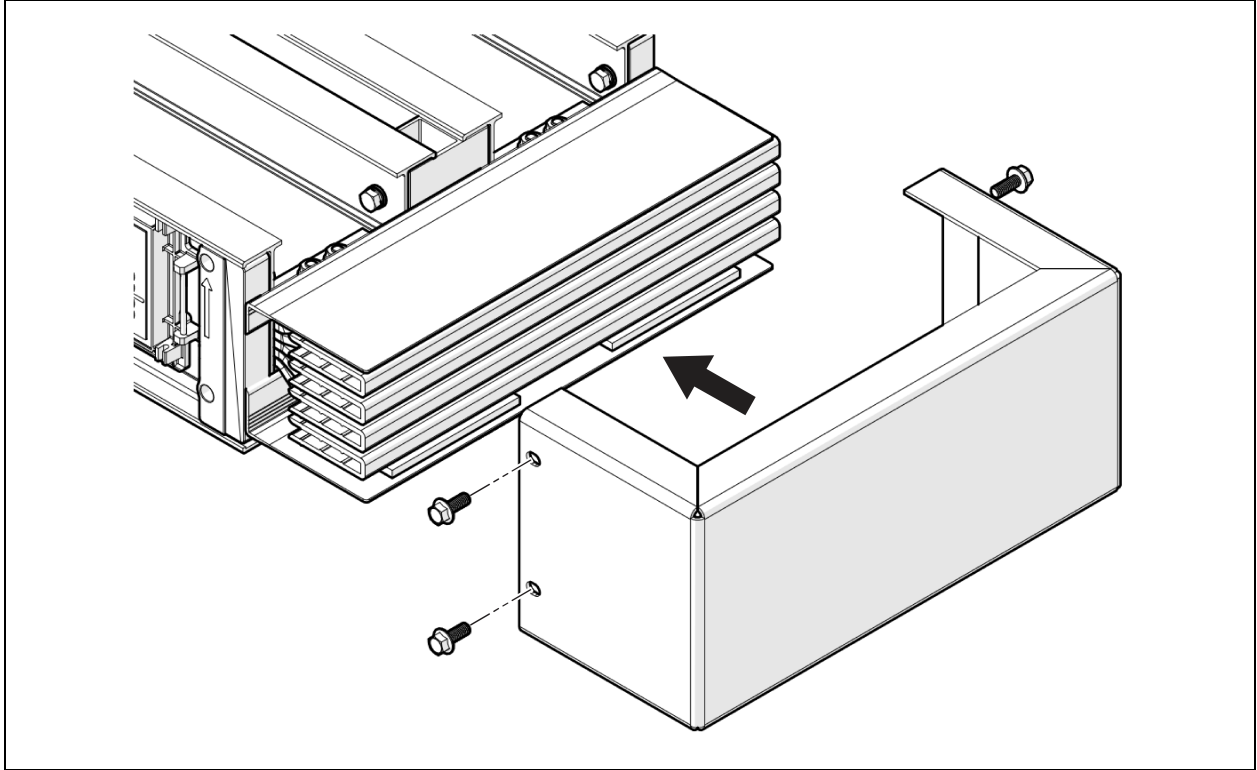

3. Compress cover onto the joint blocks on each side of the busway.
4. Alternate tightening of M8 fasteners to ensure the end cap housing is centered and aligned to the bus section. Torque the end cap housing to the joint block to 10 Nm (7.4 ft-lbs).

NOTE: Compression clamps can also be used to fit the end cap to the busway before fastening.



CAUTION: To avoid stripping joint block threaded inserts, hand start the joint cover screws before using a driver or torque wrench.

6.4 Cable End Box

NOTE: Inspect the entire route for any obstructions before installation.

1. Install/hang the box at the correct height in accordance with the approved drawings. Hanging brackets are provided based on the box orientation, see **Figure 6.25** on the facing page.

Figure 6.25 Cable End Box

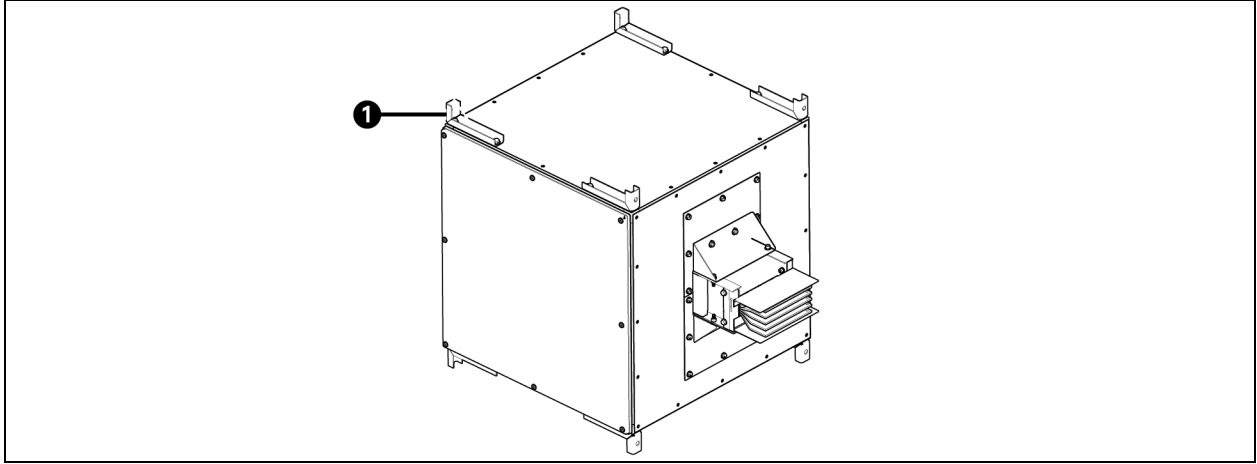

Item	Description
1	Hanging brackets (specific to application)

2. Apply a plumb line or laser level from the start of the run to the end of the run as a guide for the installation of the busway run.
3. Open cable end box door to perform a visual inspection and identify connection points.
4. Identify grounding connection point. See **Figure 6.26** below.

Figure 6.26 Grounding Point

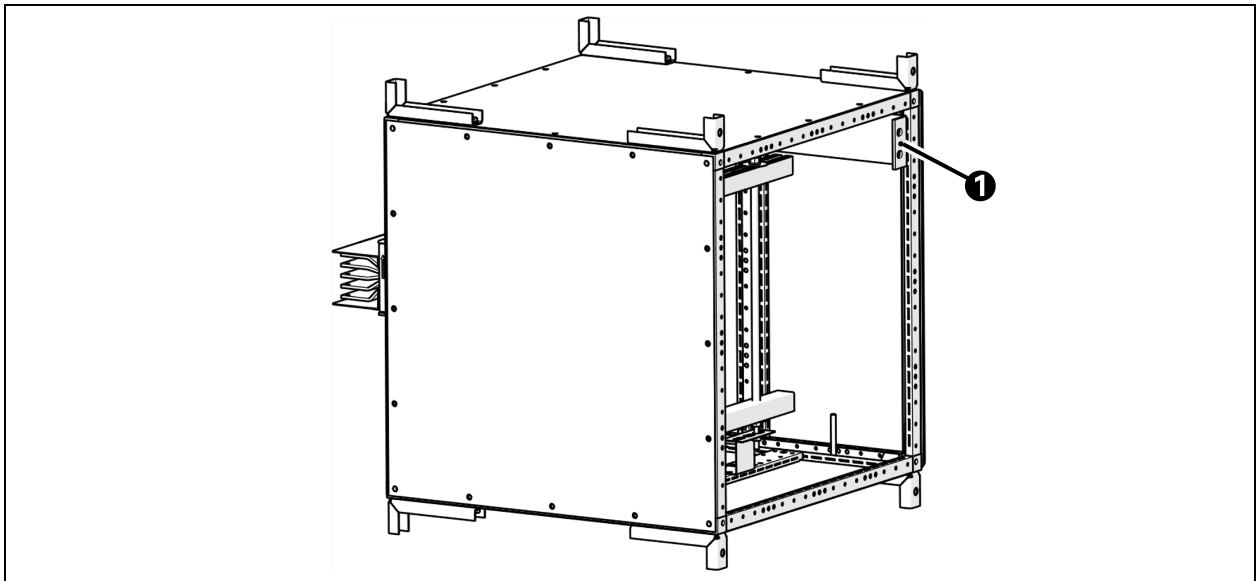

Item	Description
1	Grounding connection point (specific to application)

5. Identify cable sequence and color code.
6. Identify gland plates available for cable exit.

7. Punch out (remove) the appropriate Cable Conduit fitting holes.
8. Add the necessary conduit glands to the gland plates.
9. Identify lug landing points and NEMA hole pattern for compression or mechanical lugs. See **Figure 6.27** below.

Figure 6.27 Cable Landing Connection

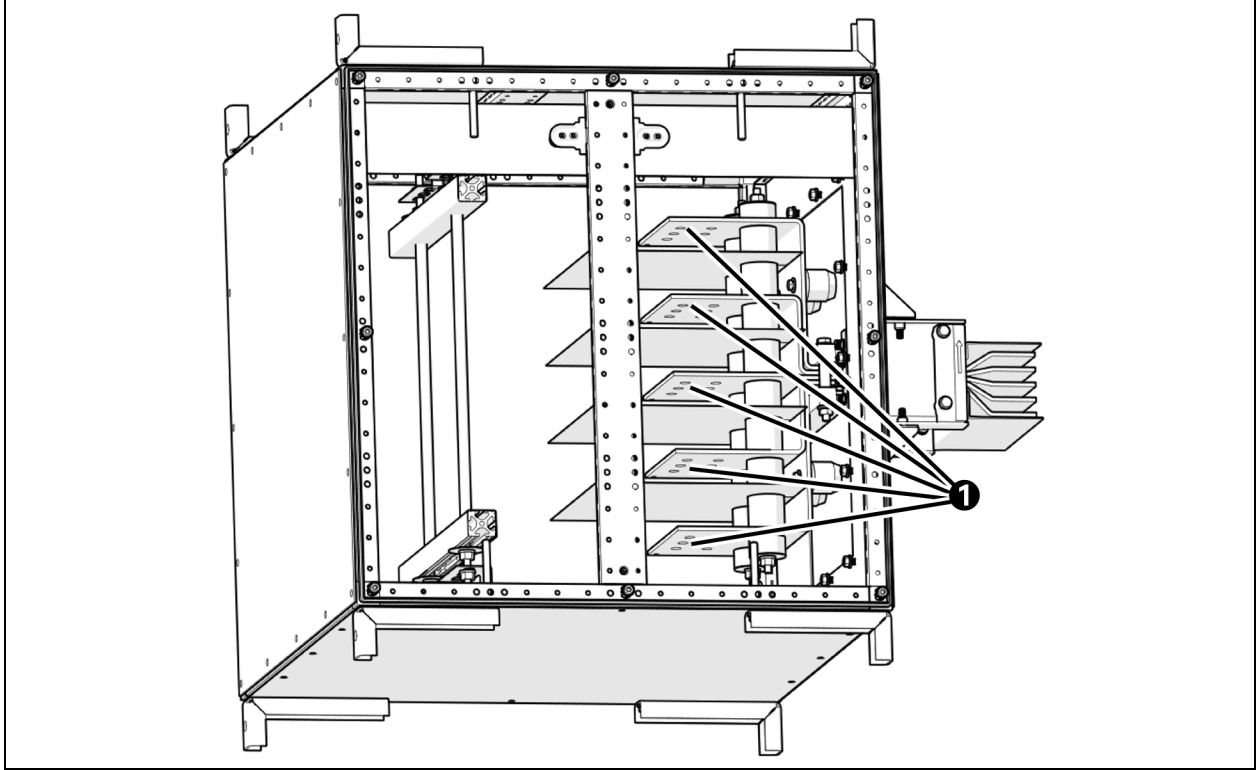

Item	Description
1	Cable landing connections.

10. Prepare field cables for termination.
11. Install and route conductors into termination box. Use appropriate hardware/lugs and makeup/torque all connections as dictated by the specific requirements of your installation. Ensure necessary clearances are maintained. See **Figure 6.28** on the facing page.
12. Torque the bolts on the lug connections to the appropriate NEMA standard torque values based on Hardware size. (Such as 54 Nm [39.83 ft-lbs] for ½" hardware.)

Figure 6.28 Properly Torque All Hardware

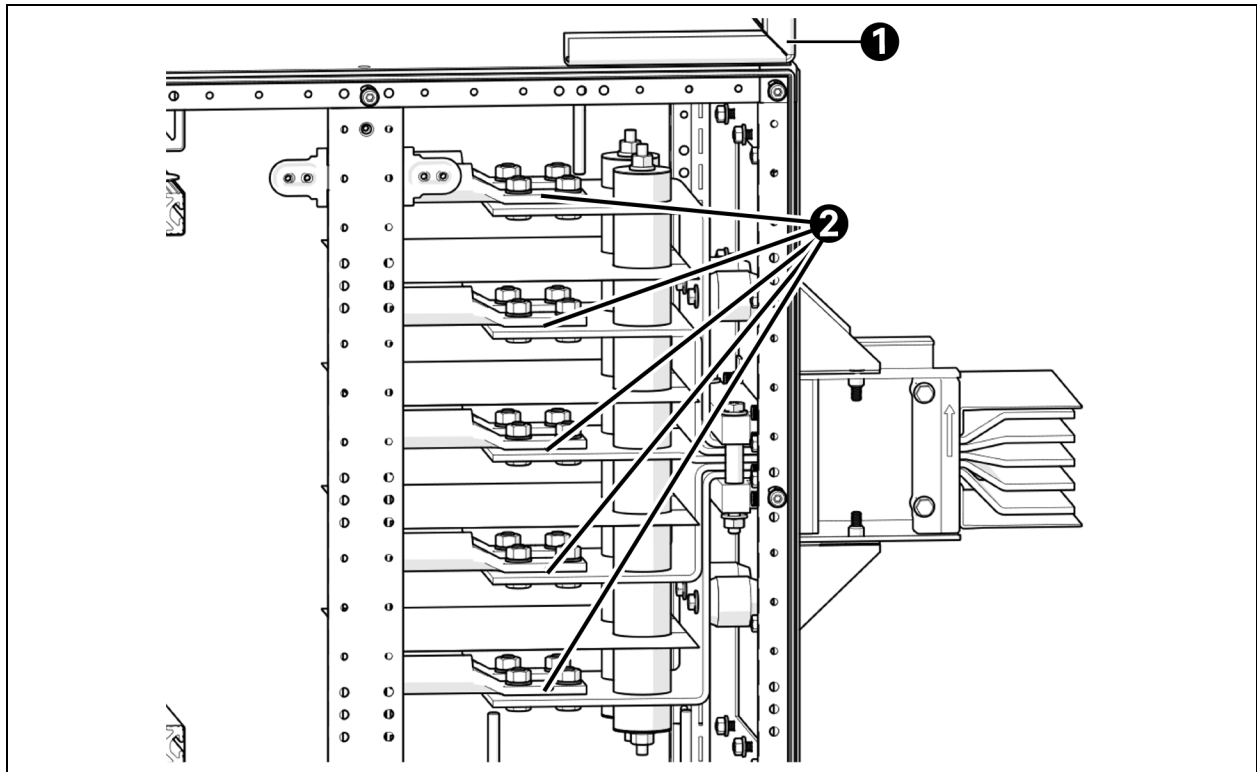

Item	Description
1	Hanging brackets (Orientations differ based on application)
2	Properly torque all hardware and ensure clearances are maintained

13. Support the cables according to the engineering drawings provided inside the door label.
14. Before closing the door, inspect for foreign object debris, tools, loose hardware, and so on.
15. Close the door and tighten Allen screws to 5 Nm (3.7 ft-lbs).
16. Connect the End Box to the adjacent busway section using a joint pack and appropriate installation method (End to End or Insertion Method) as dictated by the installation.

6.5 Expansion Units

1. Review the engineered design for supporting, securing, and anchoring the expansion unit.
2. Install the framing structure (channel strut) according to the engineering drawing.



CAUTION: Fixing points are to be agreed upon with the Vertiv Engineering team to ensure effective operation of the expansion unit.

3. Inspect the expansion unit for any damage.



CAUTION: Expansion units are fitted with transport brackets needed for shipping and installation. Remove these transport brackets only after the entire bus run is installed and all components have been secured in place. Removing this bracket before all components are fixed in place will render the expansion unit ineffective.

NOTE: The expansion unit has a fixed and a floating section. Ensure that the fixed section is the section that is secured and the floating section is permitted to move. The plan drawings must note the fixed and floating end.

4. Lift the expansion unit using a lift assist onto the supporting structure. Maintain lift support until the expansion is fully installed.
5. Vertically and horizontally align the expansion unit to the busway segments.
6. Secure the hardware on the fixed end of the expansion unit according to the engineering drawing.
7. Secure the fixer brackets to the busway housing and to the strut channel, then apply torque to 10 Nm.
8. Install the Joint Packs. Refer to the sections above regarding Joining Busway Sections using End to End or Side Installation methods.
9. After the bus run has been fully installed and secured in place, remove the transport bracket.

Figure 6.29 Expansion Module

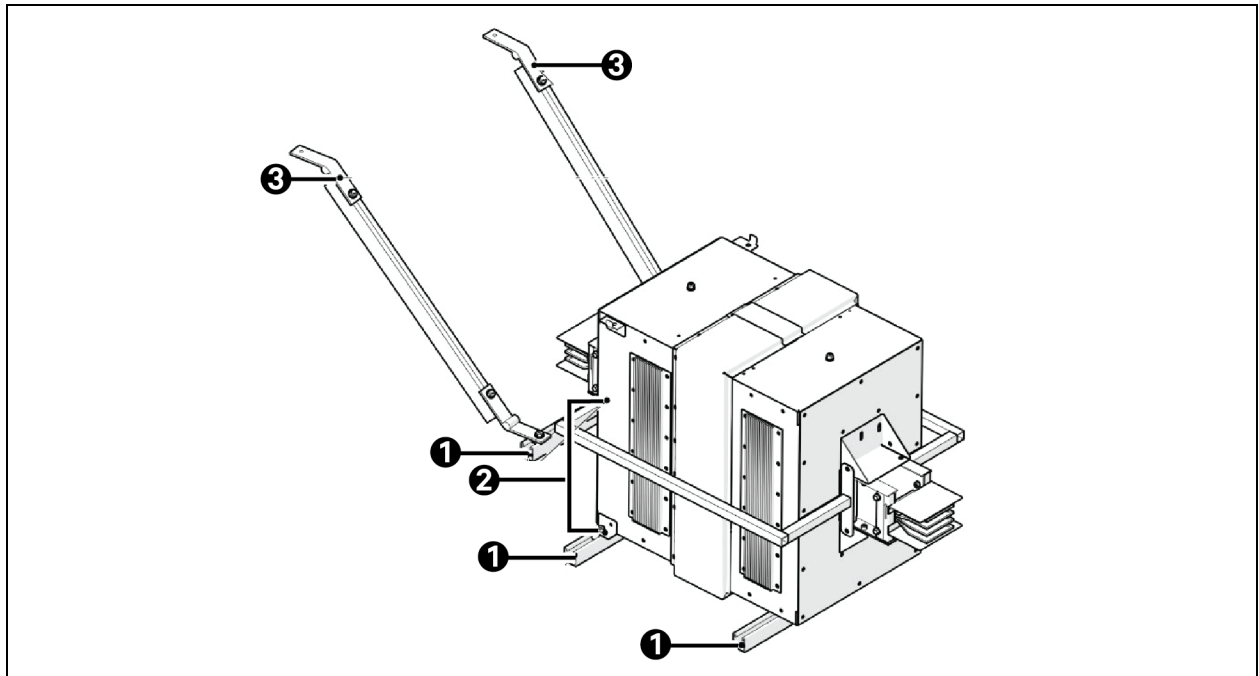

Item	Description
1	Strut Support
2	Fixing Brackets
3	Gusset anchoring to building structure

Figure 6.30 Typical Expansion Module Brace

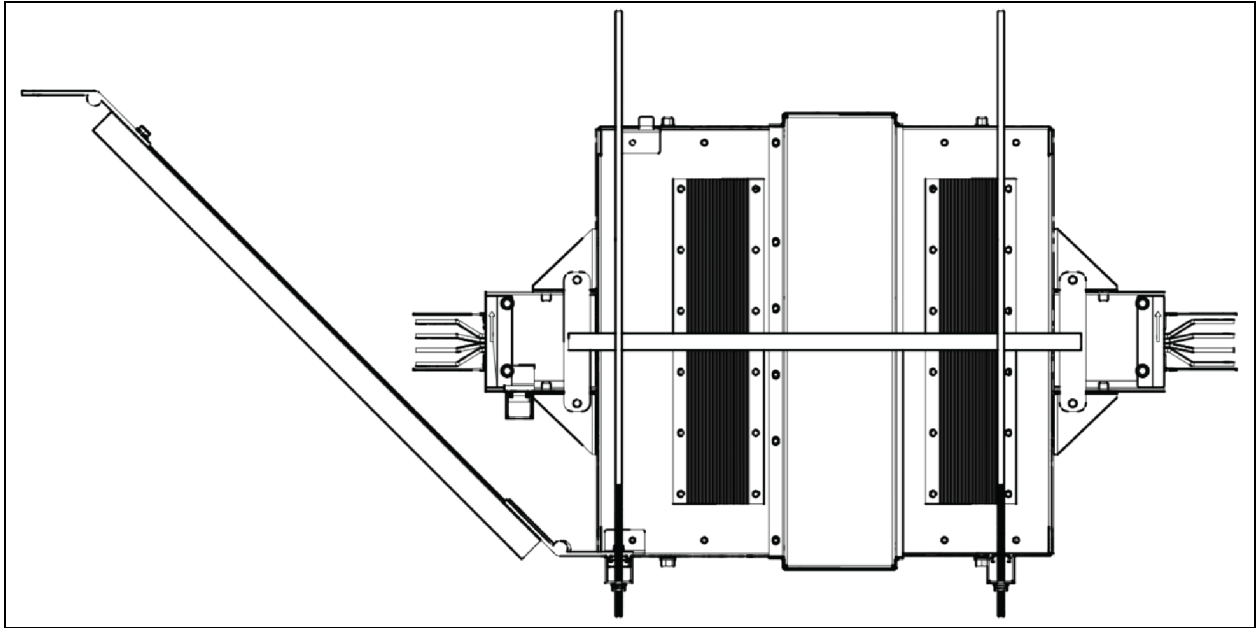

6.6 Busplug Slot Cover

1. A cover is required over unused busplug positions to increase the ingress protection level to the required standard.

NOTE: Screw is torqued only to finger-tight, ensuring slight compression of the gasket.

2. When fitting a busplug, the cover is removed.

NOTE: Store for future use. If a new cover lid is needed, order part number UL-Base-Lid.

3. When reinstalling the cover lid, insert the hinge side first at a 90 degree angle to snap in place, then swing closed.
4. The **Figure 6.31** on the next page shows the removal of the cover.

Figure 6.31 Busplug Slot Cover

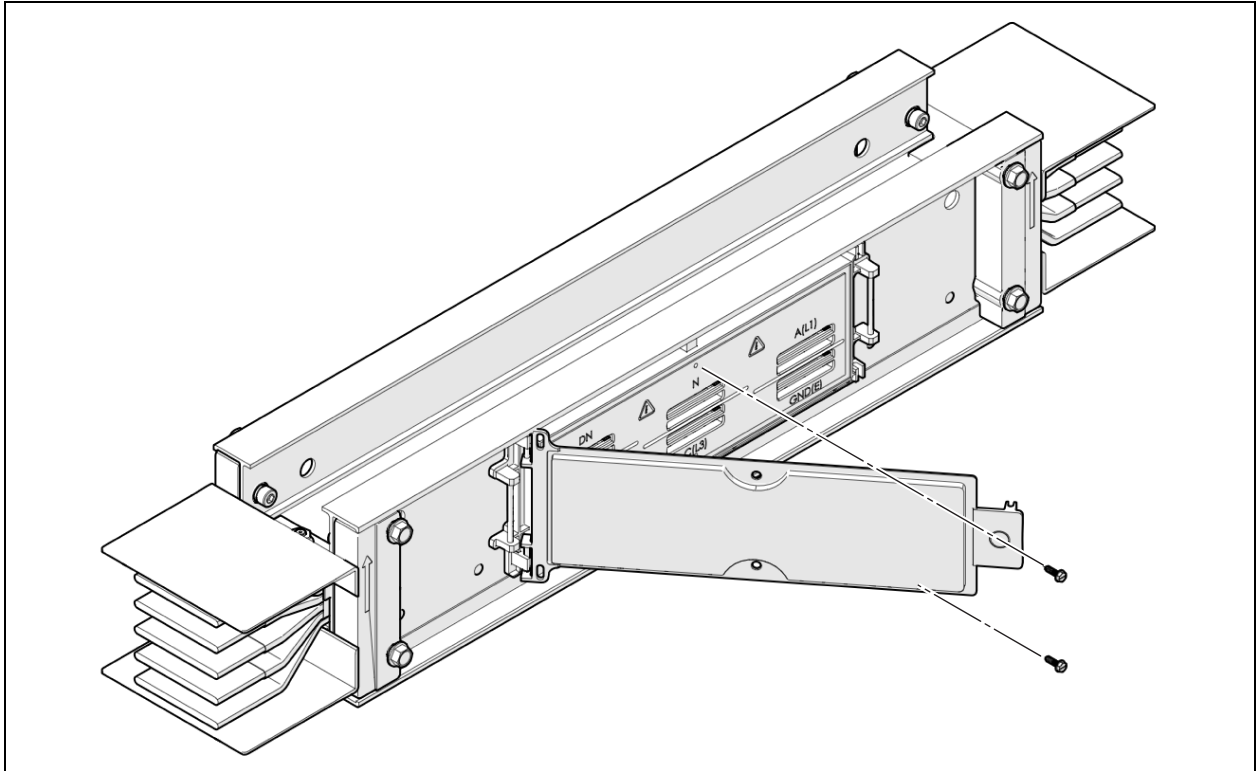

6.7 Busplug

NOTE: For specific instruction, refer to the busplug installation instructions provided inside the busplug.

1. In accordance with isolation procedures and risk assessments to be carried out by the installer. The installer must isolate the electric busway and ensure that it is not energized.



WARNING! Busplugs shall not be inserted into busplug slots while the busway is energized.

2. Remove the two screws affixing the lid to the busway. Rotate off the slot lid and store lid and screws for future use.
3. Inspect tap off slot in the busway for foreign objects, debris, or crack damage in the plastics.
4. Remove the packaging of busplug unit and check for any damage and the busplug contacts are visually in line.



WARNING! Hazardous voltage and exposed energized electrical conductors will cause explosion, death or serious injury. Switch OFF this busplug before installing on or removing from busduct.

Figure 6.32 Busplug C-Clamps

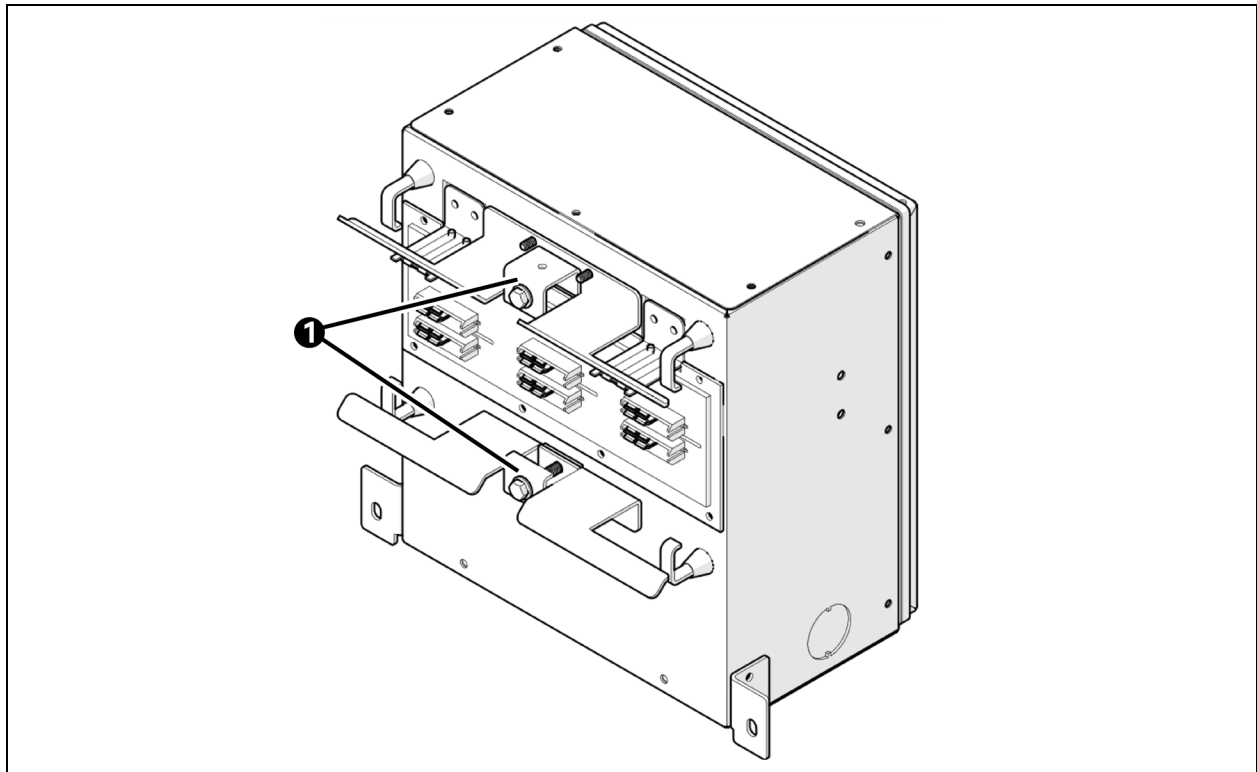

Item	Description
1	C-Clamps

5. Unscrew both C-Clamps as shown in **Figure 6.32** above.
6. To open the door rotate the latch 90 degrees in counter clockwise direction with a flat screwdriver.
7. Open the door and loosen the interlock hook screws enough to rotate the hooks to clear the busway housing (but not enough for them to come out), to allow the busplug to mount onto the busway.
8. Move the Busplug to the busway housing such that both earth contacts line up with the earth slots in the busway housing, shown in **Figure 6.33** on the next page.

Figure 6.33 Busplug Earth Contacts and Busway Earth Slots

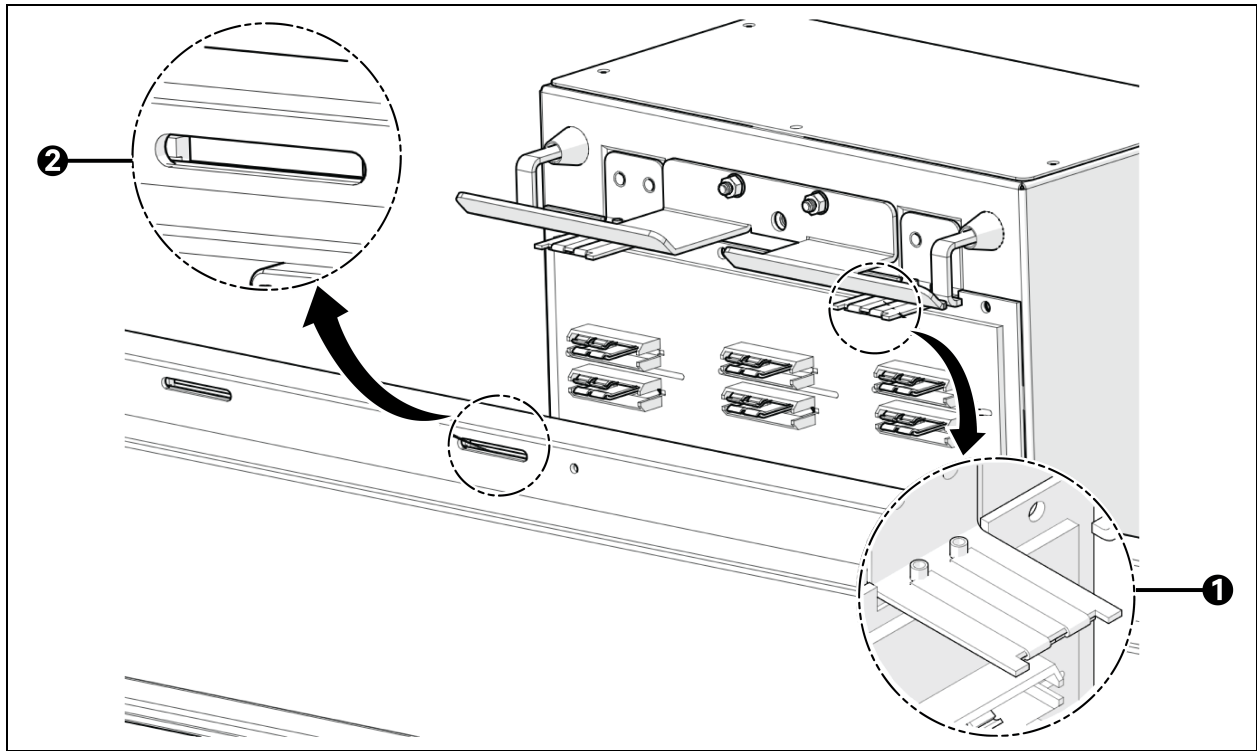

Item	Description
1	Earth contact
2	Busway earth slot for busplug

NOTE: The Earth contact is the first feature to make contact with the busway housing.

9. Orienting the busplug parallel to the busway, carefully insert the busplug into the busway plug-in opening.



CAUTION: The box cannot be inserted upside down as the ground stabs (Earth Contacts) prevent this. Install the busplug level to the busway. Tilting the busplug could damage the busway plug-in opening.

10. Insert the busplug into the busplug slot until the Busplug is fully flush to the face of the slot.
11. Affix top and bottom interlock hooks to the busway housing flanges, see **Figure 6.34** on the facing page.

NOTE: Verify that the J-hooks are still engaged to the clamping mechanism before continuing.

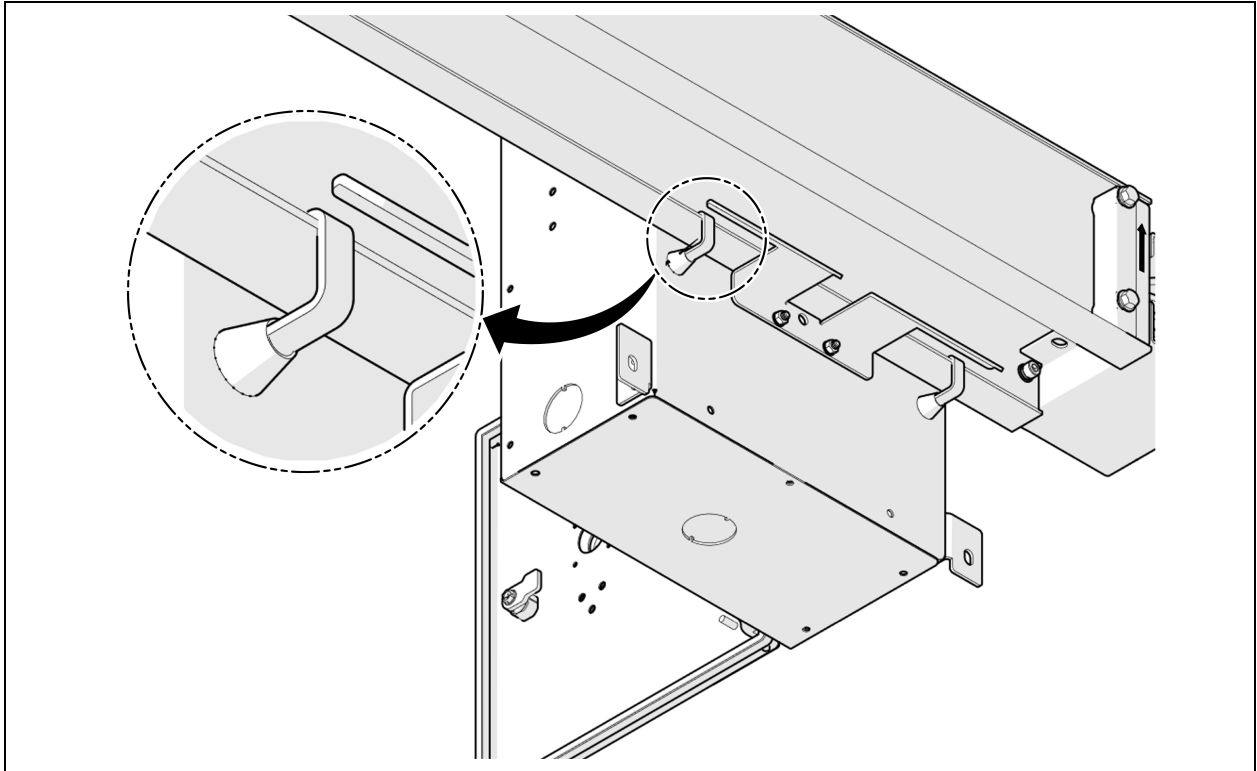
Figure 6.34 Busplug J-hooks

12. Using a T-bar or 6 mm hex Allen wrench and calibrated torque wrench, torque the interlock screws to 4 Nm. See **Figure 6.35** on the next page.

Figure 6.35 Busplug Clamping Mechanism Interlock Screws

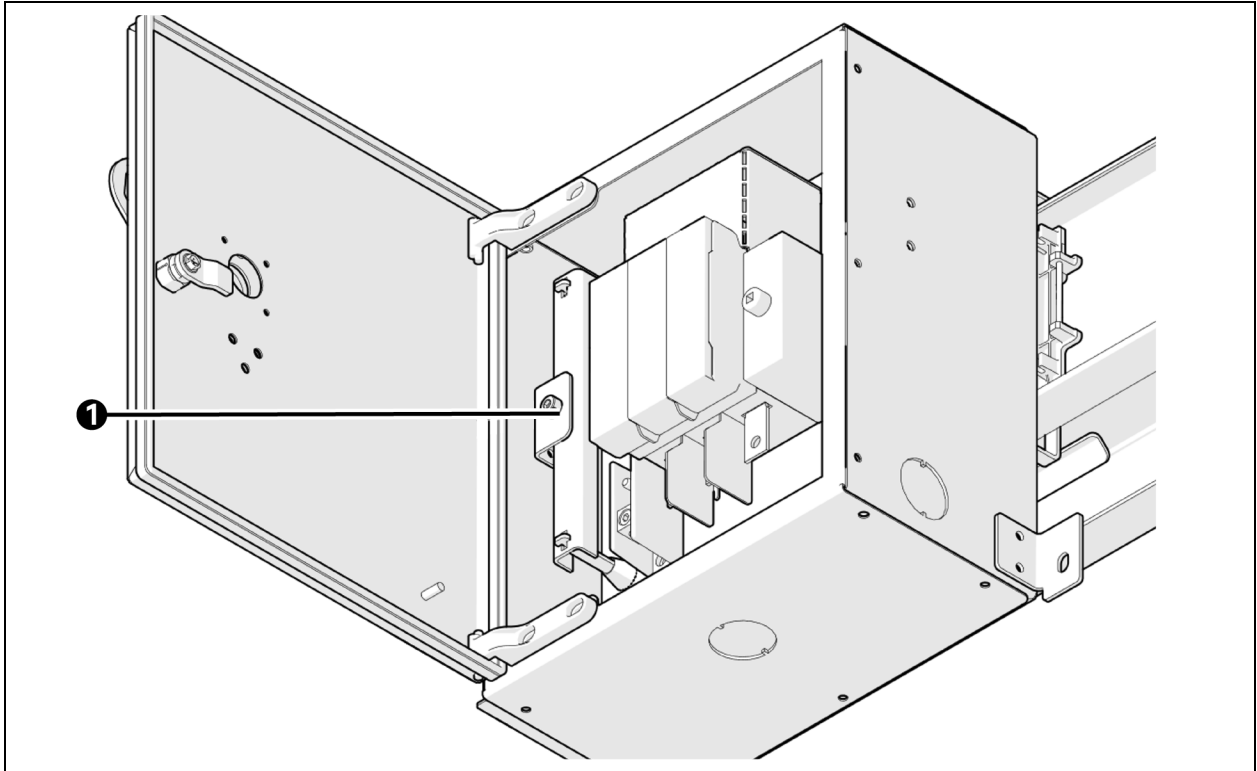

Item	Description
1	Interlock screw

13. Close the door and tighten the latch ¼ turn Clockwise.
14. Re-affix the C-Clamps to the back of the busplug and tighten hardware to 15 Nm (11 ft-lbs).

Figure 6.36 Reattach C-Clamp Installation

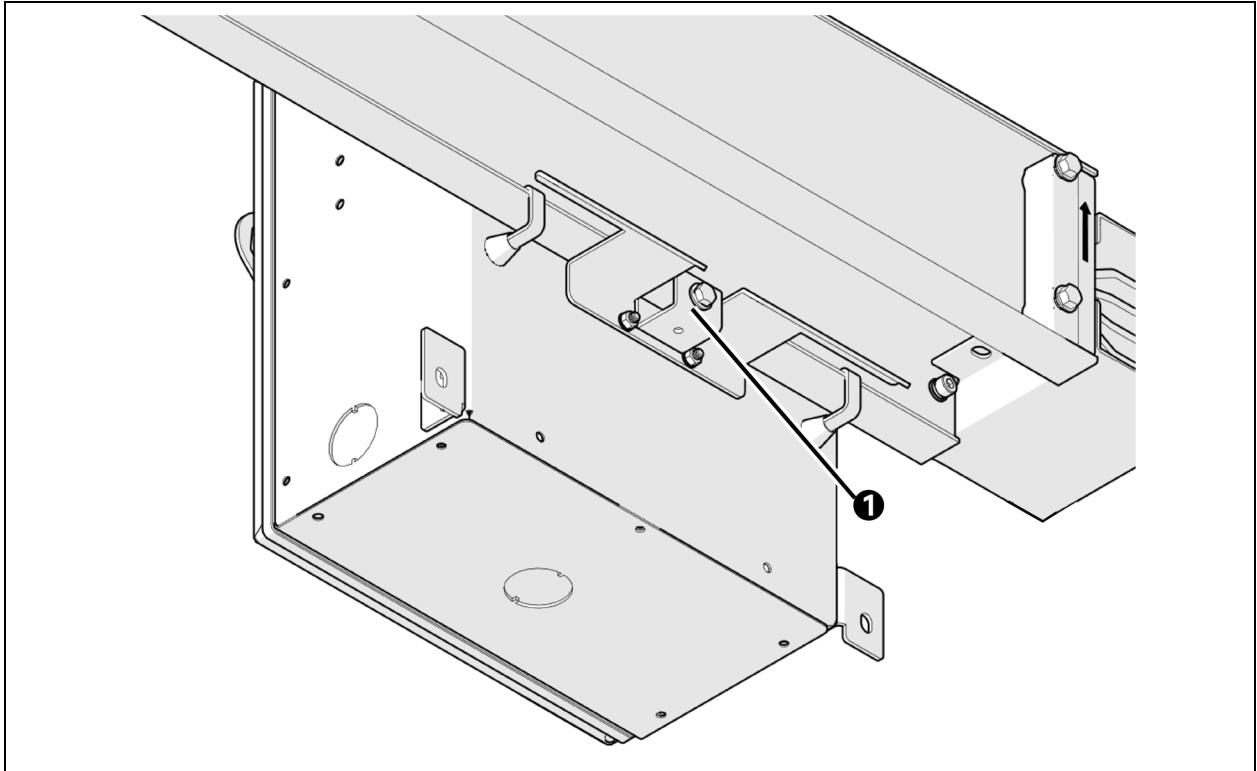

Item	Description
1	Re-attach and properly torque C -Clamps to 15 Nm (11 ft-lbs).

NOTE: Additional brackets for drop rod hangers are provided for larger busplugs.

15. Perform an overall check for any debris, dust, or misalignment.
16. Insulation resistance test installation prior to energization of busway.
17. If a neutral line is present, ensure the neutral link is connected before turning the busplug ON.



CAUTION: If removing the line side shield for any reason.

This page intentionally left blank

7 Pre-Energization

1. Ensure all busplug boxes have been correctly installed as instructed and are in the Off position for insulation resistance testing to ensure that no field wiring is being tested as part of the initial busway testing.
2. Ensure all connections to the busways have been disconnected.
3. Verify that all joints have been torqued according to the recommended setting and have not been subsequently loosened. Ensure all joint covers are firmly secured.
4. The testing procedure must be performed and documented as per Vertiv™ High PowerBar (HPB) UL 857 standard testing. (Refer to NEMA BU 1.1-2010, Section 7).

7.1 Pre-Energization Testing

1. Perform a continuity test to verify continuity and polarity of entire busway run.
2. A contact resistance test to check the resistance of the joints through the entire length.
3. An insulation resistance test, 1000 VDC between phases of opposite polarity and phases to ground. Readings will vary widely from site to site due to length of run, humidity, temperature, and site conditions. If readings less than 1 mega ohm for a 100 foot run are obtained ($\text{mega ohms} = 100 / \text{length of busway in feet}$), measures must be taken to identify the location of the low resistance level and appropriate actions taken to increase the resistance level. This test should only be carried out by competent personnel.

This page intentionally left blank

8 Energizing

1. When reconnecting the system prior to energization, ensure correct phasing and rotation is achieved by testing prior to energizing the supply.
2. Verify all busplugs are turned off prior to energizing.
3. Ensure all the connections to busway is reinstated.
4. Verify that all joints have been torqued according to the recommended setting and have not been subsequently loosened. Ensure all joint covers are firmly secured.
5. All connected load to the busway trunking must be isolated prior to energizing the busway system.
6. The busway must be energized immediately after following [step 1](#) to [step 4](#).
 - Energizing electrical circuits shall be performed by authorized and qualified personnel in accordance with site permits and approved procedures.
 - The main supply switch to the busway is to be energized first.
 - When energizing, if applicable, reduce the protective device settings of the circuit breaker to the minimum settings.
 - Visually inspect the energized busway route to look for any anomalies. Listen for noises from the system as this could indicate untightened cover plates.
 - Following the successful closing of the supply breaker, close the circuit breakers supplying the connected loads (via Busplugs) one by one. Recheck for abnormal conditions.

Table 8.1 Prior to Energizing

Prior to Energizing
Verify correct rotation/phasing.
Perform installation verification inspection.
Ensure all joints are installed per requirements.
Ensure all joint pack compression nuts are torqued to 90 Nm.
Ensure all joint pack jam nuts are torqued to 70 Nm.
Ensure all joint cover plates and end caps are torqued to 10 Nm.
Verify all joints have been fully torqued and marked.
Verify all covers have been installed, torqued, and marked. This is performed after installation verification inspection.
Ensure all busplug boxes are correctly installed and are in the OFF position. Ensure all other connections to busway are disconnected and made safe for testing.
Always conduct a continuity test to ensure bus connection are correct.
Perform a DLRO (contact resistance) of all joints.
Perform an insulation resistance (megger) test @1000 VDC to verify insulation integrity.
Ensure all PowerBar standard testing procedures are followed.
Installation verification inspection completed.
Continuity test completed.
DLRO test completed.

Table 8.1 Prior to Energizing (continued)

Prior to Energizing
Insulation resistance test completed.
Ready to make final connections and checks prior to energizing.
Prior to energizing, verify isolation of loads.

9 Maintenance of Busplug Module

Refer to NEMA BU 1.1-2010, Section 9. As with the main busway system, the joints require checks on the busplug connections. Thermal imaging can identify localized high temperature. This should be performed annually or after any severe electrical short circuit or ground fault or if the busway has been subjected to a liquid spill. The infrared temperature scan should be performed on all electrical connections and the busway enclosure while the busway is energized and operating under maximum load conditions. A permanent record should be kept.

- As previously described, upon identifying a local problem, preventative maintenance must be investigated with the busway isolated.
- If discoloration has occurred on the contact surfaces due to overheating, ensure the gap between contacts are consistent and have not been damaged during transport. If the contacts have been damaged, contact Vertiv.
- If the joint pack components or busbars show signs of discoloration, degradation, or arcing, the cause must be determined. The joints should then be cleaned and re-tightened, and joint bolt torque checked. If adverse overheating has occurred, contact Vertiv for further instructions.
- Visually check the installation of the busplug module, check clamping mechanism, check door interlocking device to ensure it still operates correctly. Check outgoing cables connections and gland tightness/integrity.
- Check the operation of the switching device positive ON and OFF operation. Examine protective device for signs of short circuit operation. If a short circuit has occurred on the equipment connected to the busplug module, check operation of device.

This page intentionally left blank

Appendices

Appendix A: Technical Support and Contacts

A.1 Technical Support/Service in the United States

Vertiv Group Corporation

24x7 dispatch of technicians for all products.

1-800-543-2378

Vertiv™ PowerBar Products

Europe - +44(0) 2835 3030

USA - +1 864 375 1757

UAE - +971 488 64062

A.2 Locations

United States

Vertiv Headquarters

505 N Cleveland Ave

Westerville, OH 43082

Europe

Via Leonardo Da Vinci 8 Zona Industriale Tognana

35028 Piove Di Sacco (PD) Italy

Asia

7/F, Dah Sing Financial Centre

3108 Gloucester Road, Wanchai

Hong Kong

This page intentionally left blank

Connect with Vertiv on Social Media



<https://www.facebook.com/vertiv/>



<https://www.instagram.com/vertiv/>



<https://www.linkedin.com/company/vertiv/>



<https://www.twitter.com/Vertiv/>



Vertiv.com | Vertiv Headquarters, 505 N Cleveland Ave, Westerville, OH 43082 USA

©2024 Vertiv Group Corp. All rights reserved. Vertiv™ and the Vertiv logo are trademarks or registered trademarks of Vertiv Group Corp. All other names and logos referred to are trade names, trademarks or registered trademarks of their respective owners. While every precaution has been taken to ensure accuracy and completeness here, Vertiv Group Corp. assumes no responsibility, and disclaims all liability, for damages resulting from use of this information or for any errors or omissions.

SL-71268_REVA_09-24