



Liebert[®] Mini-Mate Variable Capacity Indoor, Water/Glycol-cooled or Air-cooled Condensing Unit

Installer/User Guide

3, 4 and 5 Ton (10.5, 14 and 17.5 kW) Capacity, Ceiling-mounted, 60 Hz

The information contained in this document is subject to change without notice and may not be suitable for all applications. While every precaution has been taken to ensure the accuracy and completeness of this document, Vertiv assumes no responsibility and disclaims all liability for damages resulting from use of this information or for any errors or omissions.

Vertiv recommends installing a monitored fluid detection system that is wired to activate the automatic closure of field-installed coolant fluid supply and return shut off valves, where applicable, to reduce the amount of coolant fluid leakage and consequential equipment and building damage. Refer to local regulations and building codes relating to the application, installation, and operation of this product. The consulting engineer, installer and/or end user is responsible for compliance with all applicable laws and regulations relating to the application, installation, and operation of this product.

The products covered by this instruction manual are manufactured and/or sold by Vertiv. This document is the property of Vertiv and contains confidential and proprietary information owned by Vertiv. Any copying, use or disclosure of it without the written permission of Vertiv is strictly prohibited.

Names of companies and products are trademarks or registered trademarks of the respective companies. Any questions regarding usage of trademark names should be directed to the original manufacturer.

Technical Support Site

If you encounter any installation or operational issues with your product, check the pertinent section of this manual to see if the issue can be resolved by following outlined procedures.

Visit <https://www.vertiv.com/en-us/support/> for additional assistance.

TABLE OF CONTENTS

1 Important Safety Instructions	1
2 Nomenclature and Components	7
2.1 Remote, Indoor Water/Glycol-cooled or Air-cooled Condensing Unit Model Number Nomenclature	7
2.2 Component Location	8
3 Pre-installation Preparation and Guidelines	9
3.1 Planning Dimensions	9
3.1.1 Location Considerations for the Indoor Water/Glycol Condensing Unit	9
3.1.2 Location Considerations for the Indoor Air-cooled Condensing Unit	10
3.2 Connections and System Setup	10
3.3 Condensing Unit Weights	10
3.4 Equipment Inspection and Handling	10
4 Installation	13
4.1 Installing Ceiling-mounted Units	13
4.1.1 Installing Suspension Rods and Mounting Ceiling Units	13
4.1.2 Guidelines for Ducted Systems	14
5 Piping and Refrigerant Requirements	17
5.1 Water/Glycol Loop Piping Guidelines	18
5.2 Refrigerant Piping	19
5.2.1 Refrigerant Piping Guidelines	20
5.2.2 Piping When Condensing Unit is Above or Below Evaporator	22
5.3 Refrigerant Line Sizes and Equivalent Lengths	23
5.3.1 Refrigerant Charge Requirements for Water/Glycol-cooled or Air-cooled Systems	23
5.4 Additional Oil Requirements for Scroll Compressors	24
5.5 Evacuation, Leak Testing, and Charging for Water/Glycol Systems	26
5.5.1 Evacuation and Leak Testing Water/Glycol-cooled Systems	26
5.5.2 Break Vacuum	28
5.5.3 Charging Water/Glycol-cooled Systems	28
5.5.4 Optimizing Refrigerant Charge on Water/Glycol Units	29
5.5.5 Documenting Refrigerant Charge on Water/Glycol-cooled Units	30
5.6 Evacuation, Leak Testing, and Charging for Air Cooled Systems	30
5.6.1 Evacuation and Leak Testing Air-cooled Systems	30
5.6.2 Break Vacuum	32
5.6.3 Charging Air-cooled Systems	32
5.6.4 Additional Compressor Oil	33
5.6.5 Documenting Refrigerant Charge and Oil Addition	34
6 Electrical Connection Requirements	35
6.1 Low Voltage, Control Connections	36

- 6.1.1 Water/Glycol-cooled Condensing Unit Control Connections 37
- 6.1.2 Air-cooled Condensing Unit Control Connections 37
- 7 Maintenance 39**
- 7.1 Coaxial Condenser Maintenance 40
- 7.2 Regulating Valve Maintenance 40
- 7.3 Glycol Solution Maintenance 40
- 7.4 Facility Fluid and Piping Maintenance for Water and Glycol Systems 41
- 7.5 Compressor Maintenance 41
 - 7.5.1 Compressor Oil 41
 - 7.5.2 Replacement Compressors 42
 - 7.5.3 Compressor Motor Burnout 42
 - 7.5.4 Unloading Solenoid(s) on a Digital Scroll Compressor 42
 - 7.5.5 Replacing the Compressor 42
- 7.6 Blower Package Maintenance 43
 - 7.6.1 Fan Impeller and Motor Bearing Maintenance 43
 - 7.6.2 Air Distribution Inspection 43
- Appendices 45**
- Appendix A: Technical Support and Contacts 45
- Appendix B: Submittal Drawings 47

1 Important Safety Instructions

SAVE THESE INSTRUCTIONS

This manual contains important safety instructions that should be followed during the installation and maintenance of the Vertiv™ Liebert® Water/Glycol-cooled or Air-cooled Condensing Unit. Read this manual thoroughly before attempting to install or operate this unit.

Only qualified personnel should move, install or service this equipment.

Adhere to all warnings, cautions, notices and installation, operating and safety instructions on the unit and in this manual. Follow all installation, operation and maintenance instructions and all applicable national and local building, electrical and plumbing codes.



WARNING! Arc flash and electric shock hazard. Open all local and remote electric power-supply disconnect switches, verify with a voltmeter that power is Off and wear appropriate, OSHA-approved personal protective equipment (PPE) per NFPA 70E before working within the electric control enclosure. Failure to comply can cause serious injury or death. Customer must provide earth ground to unit, per NEC, CEC and local codes, as applicable. Before proceeding with installation, read all instructions, verify that all the parts are included and check the nameplate to be sure the voltage matches available utility power. The Vertiv™ Liebert® iCOM™ controller does not isolate power from the unit, even in the “Unit Off” mode. Some internal components require and receive power even during the “Unit Off” mode of the Liebert® iCOM™ controller. The only way to ensure that there is NO voltage inside the unit is to install and open a remote disconnect switch. Refer to unit electrical schematic. Follow all local codes.



WARNING! Risk of electric shock. Can cause equipment damage, injury or death. Open all local and remote electric power supply disconnect switches and verify with a voltmeter that power is off before working within any electric connection enclosures. Service and maintenance work must be performed only by properly trained and qualified personnel and in accordance with applicable regulations and manufacturers’ specifications. Opening or removing the covers to any equipment may expose personnel to lethal voltages within the unit even when it is apparently not operating and the input wiring is disconnected from the electrical source.



WARNING! Risk of electric shock. Can cause serious injury or death. The Liebert® iCOM™ microprocessor does not isolate power from the unit, even in the "Unit Off" mode. Some internal components require and receive power even during the "unit off" mode of the Liebert® iCOM™ control. Open all local and remote electric power disconnect switches and verify with a voltmeter that power is Off before working on any component of the system.



WARNING! Risk of over-pressurization of the refrigeration system. Can cause explosive discharge of high-pressure refrigerant, loss of refrigerant, environmental pollution, equipment damage, injury, or death. This unit contains fluids and gases under high pressure. Use extreme caution when charging the refrigerant system. Do not pressurize the system higher than the design pressure marked on the unit's nameplate. Relieve pressure before cutting into or making connections/disconnections to the piping system. Local building or plumbing codes may require installing a pressure-relief device in the system. Consult local building and plumbing codes for installation requirements of additional pressure-relief devices when isolation valves are field installed. Do not isolate any refrigerant circuit from over-pressurization protection.



WARNING! Risk of contact with high speed, rotating fan blades. Can cause injury or death. Open all local and remote electric power supply disconnect switches, verify with a voltmeter that power is off, and verify that all fan blades have stopped rotating before working in the unit cabinet.



WARNING! Risk of ceiling collapse and heavy unit falling. Can cause building and equipment damage, serious injury or death. Verify that the supporting roof structure is capable of supporting the weight of the unit(s) and the accessories, see **Table 3.2** on page 10, for unit weights. Be sure to securely anchor the top ends of the suspension rods. Make sure all nuts are tight.



WARNING! Risk of improper moving. Can cause equipment damage, injury or death. Use only lifting equipment that is rated for the unit weight by an OSHA-certified rating organization. The center of gravity varies depending on the unit size and selected options. The slings must be equally spaced on either side of the center of gravity indicator.

See **Table 3.2** on page 10, for unit weights.



WARNING! Risk of improper piping installation, leak checking, fluid chemistry and fluid maintenance can cause equipment damage and personal injury. Installation and service of this equipment should be done only by qualified personnel who have been specially-trained in the installation of air-conditioning equipment and who are wearing appropriate, OSHA-approved PPE.



WARNING! Risk of improper wiring, piping, moving, lifting and handling. Can cause equipment damage, serious injury or death. Installation and service of this equipment should be done only by qualified personnel who have been specially-trained in the installation of air-conditioning equipment and who are wearing appropriate, OSHA-approved PPE.



WARNING! Risk of improper wire sizing/rating and loose electrical connections. Can cause overheated wire and electrical connection terminals resulting in smoke, fire, equipment and building damage, injury or death. Use correctly sized copper wire only and verify that all electrical connections are tight before turning power On. Check all electrical connections periodically and tighten as necessary.



CAUTION: Risk of excessive refrigerant line pressure. Can cause tubing and component rupture resulting in equipment damage and personal injury. Do not close off refrigerant-line isolation valve for repairs unless a pressure-relief valve is field-installed in the line between the isolation valve and the check valve. The pressure-relief valve must be rated 5% to 10% higher than the system-design pressure. An increase in ambient temperature can cause the pressure of the isolated refrigerant to rise and exceed the system-design pressure rating (marked on the unit nameplate).



CAUTION: Risk of contact with sharp edges, splinters, and exposed fasteners. Can cause injury. Only properly trained and qualified personnel wearing appropriate, OSHA-approved PPE should attempt to move, lift, remove packaging from or prepare the unit for installation.



CAUTION: Risk of contact with hot surfaces. Can cause injury. The compressor, refrigerant-discharge lines, and some electrical components are extremely hot during unit operation. Allow sufficient time for them to cool to a touch-safe temperature before working within the unit cabinet. Use extreme caution and wear appropriate, OSHA-approved PPE when working on or near hot components.



CAUTION: Risk of contacting caustic substances. Can cause injury. Avoid touching or contacting the gas and oils with exposed skin. Severe burns will result. Wear appropriate, OSHA-approved PPE when handling contaminated parts.

NOTICE

Risk of improper power-supply connection. Can cause equipment damage and loss of warranty coverage.

Prior to connecting any equipment to a main or alternate power source (for example: back-up generator systems) for start-up, commissioning, testing, or normal operation, ensure that these sources are correctly adjusted to the nameplate voltage and frequency of all equipment to be connected. In general, power-source voltages should be stabilized and regulated to within $\pm 10\%$ of the load nameplate nominal voltage. Also, ensure that no three-phase sources are single-phased at any time.

NOTICE

Risk of oil contamination with water. Can cause equipment damage.

Because water is the enemy of a reliable refrigeration system, extreme care must be used when opening systems during service. If water is absorbed into the POE oil, it will not be easily removed and will not be removed through the normal evacuation process. If the oil is too wet, it may require an oil change. POE oils also have a property that makes them act as a solvent in a refrigeration system. Maintaining system cleanliness is extremely important because the oil will tend to bring any foreign matter back to the compressor.

NOTICE

Risk of leaking water/glycol. Can cause equipment and building damage.

Improper installation, application, and service practices can result in water leakage from the unit. Do not mount this unit over equipment and furniture that can be damaged by leaking water. Install a water-tight drain pan with a drain connection under the cooling unit and the ceiling-mounted water/glycol condensing unit. Route the drain pan to a frequently-used maintenance sink so that running water can be observed and reported in a timely manner. Post a sign to alert people to report water flowing from the secondary drain pan. We recommend installing monitored leak detection equipment for the unit and supply lines and in the secondary drain pan. Check drain lines periodically for leaks, sediment buildup, obstructions, kinks and/or damage and verify that they are free running.

NOTICE

Risk of piping-system corrosion and freezing fluids. Can cause leaks resulting in equipment and expensive building damage. Cooling coils and piping systems are at high risk of freezing and premature corrosion. Fluids in these systems must contain an inhibitor to prevent premature corrosion.

The system coolant fluid must be analyzed by a competent fluid-treatment specialist before start up to establish the inhibitor level and evaluated at regularly scheduled intervals throughout the life of the system to determine the pattern of inhibitor depletion. The fluid complexity and variations of required treatment programs make it extremely important to obtain the advice of a competent and experienced fluid-treatment specialist and follow a regularly scheduled coolant-fluid system-maintenance program.

Fluid chemistry varies greatly as do the required additives, called inhibitors, that reduce the corrosive effect of the fluids on the piping systems and components.

The chemistry of the coolant fluid used must be considered, because some sources may contain corrosive elements that reduce the effectiveness of the inhibited formulation. Sediment deposits prevent the formation of a protective oxide layer on the inside of the coolant system components and piping. The coolant fluid must be treated and circulating through the system continuously to prevent the buildup of deposits and/or growth of bacteria. Proper inhibitor maintenance must be performed to prevent corrosion of the system.

Consult fluid manufacturer for testing and maintenance of inhibitors.

Commercial-grade coolant fluid is generally less corrosive to the common metals of construction than water itself. It will, however, assume the corrosivity of the coolant fluid from which it is prepared and may become increasingly corrosive with use if not properly inhibited.

Vertiv recommends installing a monitored fluid-detection system that is wired to activate the automatic-closure of field-installed coolant-fluid supply and return shut-off valves to reduce the amount of coolant-fluid leakage and consequential equipment and building damage. The shut-off valves must be sized to close-off against the maximum coolant-fluid system pressure in case of a catastrophic fluid leak.

NOTICE

Risk of frozen pipes and corrosion from improper coolant mixture. Can cause water leaks resulting in equipment and building damage.

When the cooling unit or piping may be exposed to freezing temperatures, charge the system with the proper percentage of glycol and water for the coldest design ambient temperature. Automotive antifreeze is unacceptable and must NOT be used in any glycol fluid system. Use only HVAC glycol solution that meets the requirements of recommended industry practices. Do not use galvanized pipe.

NOTICE

Risk of no-flow condition. Can cause equipment damage. Do not leave the water/coolant fluid-supply circuit in a no-flow condition. Idle fluid allows the collection of sediment that prevents the formation of a protective oxide layer on the inside of tubes. Keep unit switched On and water/coolant fluid-supply circuit system operating continuously.

NOTICE

Risk of doorway/hallway interference. Can cause unit and/or structure damage. The unit may be too large to fit through a doorway or hallway while on the skid. Measure the unit and passageway dimensions, and refer to the installation plans prior to moving the unit to verify clearances.

NOTICE

Risk of damage from forklift. Can cause unit damage. Keep tines of the forklift level and at a height suitable to fit below the skid and/or unit to prevent exterior and/or underside damage.

NOTICE

Risk of improper storage. Can cause unit damage.

Keep the unit upright, indoors and protected from dampness, freezing temperatures and contact damage.

Agency Listed

Standard 60-Hz units are CSA Certified to the harmonized U.S. and Canadian product safety standard CSA C22.2 No 236/UL 1995 for “Heating and Cooling Equipment” and are marked with the CSA c-us logo.



This page intentionally left blank

2 Nomenclature and Components

This section describes the model number for Vertiv™ Liebert® Indoor Water/Glycol-cooled or Air-cooled Condensing Units and components.

2.1 Remote, Indoor Water/Glycol-cooled or Air-cooled Condensing Unit Model Number Nomenclature

Table 2.2 on the next page describes each digit of the model number.

Table 2.1 Water/Glycol Condensing Unit Model Number Example

1	2	3	4	5	6	7	8	9	10
M	T	C	3	8	W	D	A	2	1

Table 2.2 Model Number Digit Definitions for Water/Glycol-cooled or Air-cooled Condensing Units

Digit and Description
Digits 1, 2, 3 = The base unit MTC = Liebert® Mini-Mate Variable Capacity condensing unit
Digit 4, 5 = Nominal Capacity 38 = 38 kBtuh, 3-ton, 60 Hz (W/G cooled) 36 = 36 kBtuh, 3-ton, 60 Hz (Air cooled) 48 = 48 kBtuh, 4-ton, 60 Hz (Air cooled) 55 = 55 kBtuh, 4-ton, 60 Hz (W/G cooled) 65 = 65 kBtuh, 5-ton, 60 Hz (Air cooled) 69 = 69 kBtuh, 5-ton, 60 Hz (W/G cooled)
Digit 6 = Cooling type W = Water/Glycol-cooled A = Air-cooled
Digit 7 = Head-pressure control D = 2-way high-pressure fluid-regulating valve (W/G cooled) T = 3-way high-pressure fluid-regulating valve (W/G cooled) L = Liebert® Lee-Temp Receiver (Air cooled)

Table 2.2 Model Number Digit Definitions for Water/Glycol-cooled or Air-cooled Condensing Units (continued)

Digit and Description
Digit 8 = Supply power A = 460 V / 3 ph / 60 Hz B = 575 V / 3 ph / 60 Hz (4- and 5-ton only) P = 208/230 V / 1 ph / 60 Hz (3-ton only) X = 277 V / 1 ph / 60 Hz (3-ton only) Y = 208/230 V / 3 ph / 60 Hz
Digit 9 = Compressor type 2 = 2-stage scroll
Digit 10 = Refrigerant 1 = R-410A field-supplied and charged

2.2 Component Location

The unit component locations are described in the submittal documents included in the [Submittal Drawings](#) on page 47 .

The following tables list the relevant documents by number and title.

Table 2.3 Component Location Drawings

Document Number	Title
DPN004989	Component location diagram 3/4/5 Ton Water/Glycol-cooled condensing unit
10031570	Component location diagram 3/4/5 Ton Air-cooled condensing unit

3 Pre-installation Preparation and Guidelines

NOTE: Before installing unit, determine whether any building alterations are required to run piping and wiring. Follow all unit dimensional drawings and refer to the submittal engineering dimensional drawings of individual units for proper clearances.

Refer to [Remote, Indoor Water/Glycol-cooled or Air-cooled Condensing Unit Model Number Nomenclature](#) on page 7, and submittal drawings to determine the type of system being installed and anticipate building alterations and piping needed.

The unit dimensions, pipe-connection locations, and piping schematics are described in the submittal documents included in the [Submittal Drawings](#) on page 47.

- Allow at least the minimum recommended clearances for maintenance and service. See the appropriate submittal drawings for dimensions.
- Be mindful of the placement of the Condensing Unit in relation to the connected evaporator unit, other units, equivalent piping distances, and differences in elevation between the Condensing Unit and connected evaporator unit.
- When applications do not meet or will exceed any of these specifications, contact your Vertiv representative.

3.1 Planning Dimensions

The unit dimensions described in the submittal documents included in the [Submittal Drawings](#) on page 47.

The following table lists the relevant documents by number and title.

Table 3.1 Dimension Planning Drawings

Document Number	Title
DPN004889	Cabinet dimensions, 3, 4, and 5 ton, Water/Glycol-cooled
10030172	Cabinet dimensions, 3, 4, and 5 ton Air-cooled condensing unit

3.1.1 Location Considerations for the Indoor Water/Glycol Condensing Unit

When determining installation locations, consider that these units contain water/glycol and that leaks from ceiling-mounted condensing units can cause damage to sensitive equipment and furniture below.

NOTICE

Risk of leaking water/glycol. Can cause equipment and building damage.

Improper installation, application, and service practices can result in water leakage from the unit. Do not mount this unit over equipment and furniture that can be damaged by leaking water. Install a water-tight drain pan with a drain connection under the cooling unit and the ceiling-mounted water/glycol condensing unit. Route the drain pan to a frequently-used maintenance sink so that running water can be observed and reported in a timely manner. Post a sign to alert people to report water flowing from the secondary drain pan. We recommend installing monitored leak detection equipment for the unit and supply lines and in the secondary drain pan. Check drain lines periodically for leaks, sediment buildup, obstructions, kinks and/or damage and verify that they are free running.

3.1.2 Location Considerations for the Indoor Air-cooled Condensing Unit

- In applications where the ceiling plenum is used as the heat rejection domain, the discharge air must be directed away from the condensing unit air inlet and a screen must be added to the end of the discharge duct to protect service personnel. Locate the air discharge a minimum of 4 ft. from an adjacent wall. Failure to do so may result in reduced air flow and poor system performance.
- If the condensing unit draws air from the outside of the building, rain hoods must be installed. Hood intake and duct work cross-sectional area dimensions should be equal to or greater than the area of the condensing unit intake flange. In addition, install a triple-layer bird screen over rain hood openings to eliminate the possibility of insects, birds, water or debris entering the unit. Avoid directing the hot exhaust air toward adjacent doors or windows.

3.2 Connections and System Setup

- Electrical service is required for all models. Electrical service must conform to national and local electrical codes. See equipment nameplate for details.
- Plan the routing of wiring and piping to the unit. Refer to the appropriate piping connection location drawings, piping schematics, and electrical connection drawings for your system in the [Submittal Drawings](#) on page 47.

3.3 Condensing Unit Weights

Table 3.2 Condensing Unit Weights

Model #	Weight, lb (kg)
MTC38W	237 (107.5)
MTC55W	237 (107.5)
MTC69W	237 (107.5)
MTC36A	350 (159)
MTC48A	408 (185)
MTC65A	408 (185)

3.4 Equipment Inspection and Handling



WARNING! Risk of improper moving, lifting, or handling of the unit. Can cause equipment damage, injury or death. Read all of the following instructions and verify that all lifting and moving equipment is rated for the weight of the unit before attempting to move, lift, remove packaging from or prepare the unit for installation. Unit weights are specified in **Table 3.2** above.



CAUTION: Risk of contact with sharp edges, splinters, and exposed fasteners. Can cause injury. Only properly trained and qualified personnel wearing appropriate, OSHA-approved PPE should attempt to move, lift, remove packaging from or prepare the unit for installation.

NOTICE

Risk of damage from forklift. Can cause unit damage. Keep tines of the forklift level and at a height suitable to fit below the skid and/or unit to prevent exterior and/or underside damage.

When the unit arrives, inspect all items for any visible or concealed damage. Report any damage to the carrier immediately and file a damage claim. Send a copy of the claim to your Vertiv representative.

If possible, maintain equipment and packaging until it is at the installation location.

This page intentionally left blank

4 Installation

4.1 Installing Ceiling-mounted Units



WARNING! Risk of ceiling collapse and heavy unit falling. Can cause building and equipment damage, serious injury or death. Verify that the supporting roof structure is capable of supporting the weight of the unit(s) and the accessories, see **Table 3.2 on page 10 . Be sure to securely anchor the top ends of the suspension rods. Make sure all nuts are tight.**

NOTICE

Risk of leaking water/glycol. Can cause equipment and building damage.

Improper installation, application, and service practices can result in water leakage from the unit. Do not mount this unit over equipment and furniture that can be damaged by leaking water. Install a water-tight drain pan with a drain connection under the cooling unit and the ceiling-mounted water/glycol condensing unit. Route the drain pan to a frequently-used maintenance sink so that running water can be observed and reported in a timely manner. Post a sign to alert people to report water flowing from the secondary drain pan. We recommend installing monitored leak detection equipment for the unit and supply lines and in the secondary drain pan. Check drain lines periodically for leaks, sediment buildup, obstructions, kinks and/or damage and verify that they are free running.

4.1.1 Installing Suspension Rods and Mounting Ceiling Units

Refer to the [Location Considerations for the Indoor Water/Glycol Condensing Unit](#) on page 9 and [Location Considerations for the Indoor Air-cooled Condensing Unit](#) on page 10 before beginning installation.

NOTE: Follow all national and local building, electrical and plumbing codes.

- The ceiling and ceiling supports of existing buildings may require reinforcements.
- Recommended clearance between ceiling grids and building structural members is the unit's height plus 3 in. (76 mm).
- Four 3/8-in.-16 TPI threaded suspension rods are required and field supplied. The factory-supplied 3/8-in.-16 TPI hardware kit includes the remaining installation hardware for rod to unit.

To install the suspension rods:

1. Install the 4 field-supplied rods by suspending them from suitable building structural members so that they will align with the 4 mounting locations on the unit base.
2. Securely anchor the top ends of the suspension rods.
3. Make sure all nuts are tight.

To lift and install the unit on the rods:

1. Referring to **Figure 4.1** below , place the hex nuts (Item 2) on the threaded rods, and add the washer, sleeve, and isolator (Items 3, 4, and 6) to the bracket holes on the unit.
2. Using a suitable lifting device that is rated for the weight of the unit (see **Table 3.2** on page 10), raise the unit and pass the threaded rods through the 4 mounting locations in the unit base.
3. Attach the threaded rods to the flanges using the washer and plain nut (Items 7 and 8) from the hardware kit to hold the unit in place as shown in **Figure 4.1** below .
4. Adjust the plain nuts to distribute the weight of the unit evenly by the rods, making sure that the unit does not rest on the ceiling grid and that the unit is level.

NOTE: The unit must be level to properly drain condensate.

5. Use the Nylock nuts to "jam" the plain nuts in place as shown in **Figure 4.1** below .

Figure 4.1 Installing threaded rods and hardware of ceiling-mounted units

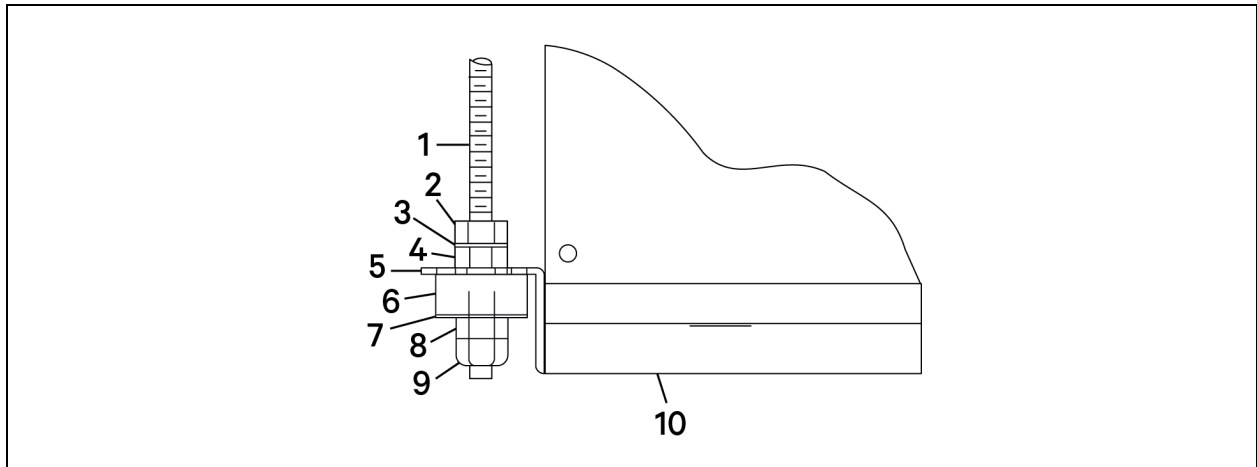

Item	Description	Item	Description
1	3/8-in. threaded rod, field-supplied	6	Isolator
2	3/8-in. hex nut	7	3/8-in. fender washer
3	3/8-in. washer	8	3/8-in. hex nut
4	Sleeve	9	3/8-in. Nylock locking nut
5	Bracket on unit	10	Unit base pan (reference)

4.1.2 Guidelines for Ducted Systems

Observe the following for all duct work:

- Duct work should be fabricated and installed in accordance with local and national codes.
- Use flexible duct work or nonflammable cloth collars to attach duct work to the unit and to control vibration transmission to the building.
- Attach the duct work to the unit using the flanges provided.
- Locate the unit and duct work so that the discharge air does not short-circuit to the return air inlet.

- If the return air duct is short or if noise is likely to be a problem, sound-absorbing insulation should be used inside the duct.
- Duct work should be suspended using flexible hangers. Duct work should not be fastened directly to the building structure.
- For multiple unit installations, space the units so that the hot condensing unit exhaust air is not directed toward the air inlet of an adjacent unit.

This page intentionally left blank

5 Piping and Refrigerant Requirements

All fluid and refrigeration connections to the unit are sweat copper. Factory-installed piping brackets must not be removed. Field-installed piping must be installed in accordance with local codes and must be properly assembled, supported, isolated and insulated. Avoid piping runs through noise-sensitive areas, such as office walls and conference rooms.

Refer to specific text and detailed diagrams in this manual for other unit-specific piping requirements.

The following pipe connections are required:

- Refrigerant piping connections between the evaporator unit and the condensing unit.
- For Water/Glycol condensing units: Connections to a water or glycol loop. See [Water/Glycol Loop Piping Guidelines](#) on the next page, for additional requirements.
- A drain line from the secondary drain pan (if applicable).

The pipe connection locations, piping general arrangement and schematics are described in the submittal documents included in the [Submittal Drawings](#) on page 47.

The following tables list the relevant documents by number and title.

Table 5.1 Piping General Arrangement Drawings

Document Number	Title
DPN004893	General arrangement, 3, 4, and 5 ton Water/Glycol condensing unit
10030175	General arrangement 3, 4, and 5 ton Air-cooled condensing unit

Table 5.2 Piping Connection Drawings

Document Number	Title
DPN004972	Primary connection locations, Water/Glycol-cooled
10030336	Primary connection locations, 3, 4, and 5 Ton Air-cooled Condensing Unit

5.1 Water/Glycol Loop Piping Guidelines



WARNING! Risk of improper piping installation, leak checking, fluid chemistry and fluid maintenance can cause equipment damage and personal injury. Installation and service of this equipment should be done only by qualified personnel who have been specially-trained in the installation of air-conditioning equipment and who are wearing appropriate, OSHA-approved PPE.

NOTICE

Risk of frozen pipes and corrosion from improper coolant mixture. Can cause water leaks resulting in equipment and building damage.

When the cooling unit or piping may be exposed to freezing temperatures, charge the system with the proper percentage of glycol and water for the coldest design ambient temperature. Automotive antifreeze is unacceptable and must NOT be used in any glycol fluid system. Use only HVAC glycol solution that meets the requirements of recommended industry practices. Do not use galvanized pipe.

NOTICE

Risk of piping-system corrosion and freezing fluids. Can cause leaks resulting in equipment and expensive building damage. Cooling coils and piping systems are at high risk of freezing and premature corrosion. Fluids in these systems must contain an inhibitor to prevent premature corrosion.

The system coolant fluid must be analyzed by a competent fluid-treatment specialist before start up to establish the inhibitor level and evaluated at regularly scheduled intervals throughout the life of the system to determine the pattern of inhibitor depletion. The fluid complexity and variations of required treatment programs make it extremely important to obtain the advice of a competent and experienced fluid-treatment specialist and follow a regularly scheduled coolant-fluid system-maintenance program.

Fluid chemistry varies greatly as do the required additives, called inhibitors, that reduce the corrosive effect of the fluids on the piping systems and components.

The chemistry of the coolant fluid used must be considered, because some sources may contain corrosive elements that reduce the effectiveness of the inhibited formulation. Sediment deposits prevent the formation of a protective oxide layer on the inside of the coolant system components and piping. The coolant fluid must be treated and circulating through the system continuously to prevent the buildup of deposits and/or growth of bacteria. Proper inhibitor maintenance must be performed to prevent corrosion of the system.

Consult fluid manufacturer for testing and maintenance of inhibitors.

Commercial-grade coolant fluid is generally less corrosive to the common metals of construction than water itself. It will, however, assume the corrosivity of the coolant fluid from which it is prepared and may become increasingly corrosive with use if not properly inhibited.

Vertiv recommends installing a monitored fluid-detection system that is wired to activate the automatic-closure of field-installed coolant-fluid supply and return shut-off valves to reduce the amount of coolant-fluid leakage and consequential equipment and building damage. The shut-off valves must be sized to close-off against the maximum coolant-fluid system pressure in case of a catastrophic fluid leak.

NOTICE

Risk of no-flow condition. Can cause equipment damage.

Do not leave the water/coolant fluid-supply circuit in a no-flow condition. Idle fluid allows the collection of sediment that prevents the formation of a protective oxide layer on the inside of tubes. Keep unit switched On and water/coolant fluid-supply circuit system operating continuously.

- Use copper piping with a brazing alloy with a minimum temperature of 1350°F (732°C), such as Sil-Fos. Avoid soft solders, such as 50/50 or 95/5.
- Follow local piping codes and safety codes.
- Qualified personnel must install and inspect system piping.
- The water/glycol-cooled system will operate in conjunction with a cooling tower, city water or drycooler.
- Contact a local water consultant regarding water quality, corrosion protection and freeze-protection requirements.
- Install manual shut-off valves at the supply and return line to each unit to permit routine service and emergency isolation of the unit.
- When the fluid quality is poor, we recommend installing a 16-20# mesh Y-strainer filter in the supply line to extend the service life of the coaxial condensers. These filters must be easily replaced or cleaned.
- Install a monitored, fluid-detection system that is wired to activate the automatic closure of field-installed coolant-fluid supply and return shut-off valves to reduce the amount of coolant fluid leakage and consequential equipment and building damage. The shut-off valves must be sized to close-off against the maximum coolant-fluid system pressure in case of a catastrophic fluid leak.
- The maximum fluid pressure is 350 psig (2413 kPa) for high-pressure systems. For applications above this pressure, contact a Vertiv representative.

Coolant-regulating Valve Requires No Adjustment

Water/glycol-cooled units include a coolant-flow regulating valve that is factory-adjusted and should not need field adjustment.

Contact Vertiv technical support before making any adjustments.

5.2 Refrigerant Piping

WARNING! Risk of over-pressurization of the refrigeration system. Can cause piping rupture, explosive discharge of high pressure refrigerant, loss of refrigerant, environmental pollution, equipment damage, injury, or death. This unit contains fluids and gases under high pressure. Use extreme caution when charging the refrigerant system. Do not pressurize the system higher than the design pressure marked on the unit's nameplate. Relieve pressure before cutting into or making connections/disconnections to the piping system. Local building or plumbing codes may require installing a pressure relief device in the system.

Consult local building and plumbing codes for installation requirements of additional pressure relief devices when isolation valves are field installed. Do not isolate any refrigerant circuits from over-pressurization protection. The Vertiv™ Liebert® MTC air condensing units include a factory installed pressure relief valve mounted on top of the receiver. The valve is rated for a maximum working pressure of 675 psig.

Table 5.3 System Refrigerant Pressures

Refrigerant R-410A		
	High Side	Low Side
Design Pressure	530 psig	235 psig
	3,655 kPa	1620 kPa
High Pressure Cutout	580 psig	N/A
	kPa	
Field installed interconnecting piping must be properly selected and installed based on local and national codes, the user manual, and the unit serial tag. Source: DPN000788, REV 15.		

NOTICE

Risk of oil contamination with water. Can cause equipment damage.

Vertiv™ Liebert® Mini-Mate3 DX systems require the use of POE (polyolester) oil. POE oil absorbs water at a much faster rate when exposed to air than previously used oils. Because water is the enemy of a reliable refrigeration system, extreme care must be used when opening systems during installation or service. If water is absorbed into the POE oil, it will not be easily removed and will not be removed through the normal evacuation process. If the oil is too wet, it may require an oil change. POE oils also have a property that makes them act as a solvent in a refrigeration system. Maintaining system cleanliness is extremely important because the oil will tend to bring any foreign matter back to the compressor.

NOTICE

Risk of improper refrigerant charging. Can cause equipment damage.

Refrigerant charge must be weighed into compressorized systems before they are started.

Split systems require two refrigerant lines between the evaporator and the condensing unit:

- One insulated copper suction line
- One copper liquid line

NOTICE

Units should never be operated with no refrigerant charge, a holding charge, a proper load or without additional oil as required added. Tag out system to prevent unauthorized personnel from accidentally starting equipment and damaging compressors if any of these conditions exist.

5.2.1 Refrigerant Piping Guidelines

- All piping must be ACR type copper.
- Factory-installed piping brackets must not be removed.
- Piping must be installed in accordance with local codes and must be properly assembled, supported, isolated, and insulated.
- Use prevailing good refrigeration practices such as piping supports, leak testing, evacuation, dehydration, and charging of the refrigeration circuits.
- Evaporators and condensing units ship with an inert-gas holding charge. Do not vent the evaporator and condensing unit until all refrigerant piping is in place, ready for connection to the unit and condensing unit.

- Use copper piping with a brazing alloy with a minimum temperature of 1350°F (732°C), such as Sil-Fos. Avoid soft solders, such as 50/50 or 95/5.
- Use a flow of dry nitrogen through the piping during brazing to prevent formation of copper oxide scale inside the piping. When copper is heated in the presence of air, copper oxide forms. POE oils will dissolve these oxides from inside the copper pipes and deposit them throughout the system, clogging filter driers and affecting other system components.
- A pure dry nitrogen flow of 1-3 ft³/min (0.5-1.5 l/s) inside the pipe during brazing is sufficient to displace the air. Control the flow using a suitable measuring device.
- Ensure that the tubing surfaces to be brazed are clean and that all burrs have been removed from the ends of the tubes.
- Ensure that all loose material has been cleaned from inside the tubing before brazing.
- Protect all refrigerant line components within 18 in. (460 mm) of the brazing site by wrapping them with a wet cloth or with a suitable heat-sink compound.
- Isolate piping from building using vibration-isolating supports.
- When sealing openings in walls and to reduce vibration transmission, use a soft, flexible material to pack around the tubes to prevent tube damage.
- When installing remote condensing units above the evaporator, the suction gas lines should be trapped at the evaporator. These traps will retain refrigerant oil in the off cycle. When the unit starts, oil in the traps is carried up the vertical risers and returns to the compressors. For rises over 25 ft (7.6 m), trap every 20 ft (6 m) or evenly-divided.
- Consult factory if piping run exceeds 150 ft (46 m) equivalent length.
- Keep piping clean and dry, especially on units with R-410A refrigerant.
- Avoid piping runs through noise-sensitive areas.
- Do not run piping directly in front of discharge air stream.
- Refrigerant oil – do not mix oil types.

Refer to ASHRAE Refrigeration Handbook for general, good-practice refrigeration piping.

NOTE: All indoor suction-line piping must have 1/2 in. minimum of insulation.

NOTE: Proper safety equipment and proper refrigeration tools are required when working with R-410A refrigerant. Check unit serial tag for correct refrigerant type before topping-off or recharging a system.

NOTE: Refrigerant R-410A uses a POE (polyolester) lubricant. The refrigerant must be introduced and charged from the cylinder only as a liquid.

NOTE: When installing field piping, you must take care to protect all refrigerant lines from the atmosphere especially when using refrigerants with POE oils. Do not allow the piping to stand open to air for more than 15 minutes. Units designed for R-410A have a compressor that contains POE oil, which quickly absorbs water from the air. The longer that the refrigerant piping is left open to air, the harder it will be to fully evacuate the system. If left open too long, the POE oil may require replacement to achieve the required vacuum level.

- Refer to [Refrigerant Line Sizes and Equivalent Lengths](#) on page 23, for recommended refrigerant piping sizes based on equivalent pipe lengths.
- Refer to [Refrigerant Charge Requirements for Water/Glycol-cooled or Air-cooled Systems](#) on page 23, for the refrigerant-charge requirements of the system.

5.2.2 Piping When Condensing Unit is Above or Below Evaporator

Refer to **Table 5.4** below, for the maximum vertical rise/fall between condensing unit and evaporator.

When installing remote condensing units above the evaporator, trap the suction gas line at the evaporator as shown in **Figure 5.1** below. Traps recommended at the base of riser exceeding 5 ft (1.5 m) and every 20 ft (6 m) of vertical rise. This trap will retain refrigerant oil during the "Off" cycle. When the unit starts, oil in the trap is carried up the vertical riser and returns to the compressor.

When installing remote condensing units below the evaporator, trap the suction gas line with an inverted trap the height of the evaporator as shown **Figure 5.1** below. This prevents refrigerant migration to the compressor during "Off" cycles. The maximum recommended vertical-level drop to condensing unit is 15 ft. (4.6 m).

Table 5.4 Pipe Length and Condensing Unit Elevation Relative to Evaporator

Maximum Equivalent Pipe Length, ft (m)	Maximum Condensing Unit Level Above Evaporator, ft (m)	Maximum Condensing Unit Level Below Evaporator, ft (m)
150 (45)	50 (15)	15 (4.6)
Maximum recommended total equivalent pipe length is 150 ft. (46 m). Suction and liquid lines may require additional specialty items when vertical lines exceed 20 ft. (6 m) and/or condensing unit installation is more than 15 ft. (4.6 m) below the evaporator. Contact Vertiv Technical Support for assistance.		

Figure 5.1 Refrigerant Piping Diagram When Condenser is Above or Below Evaporator

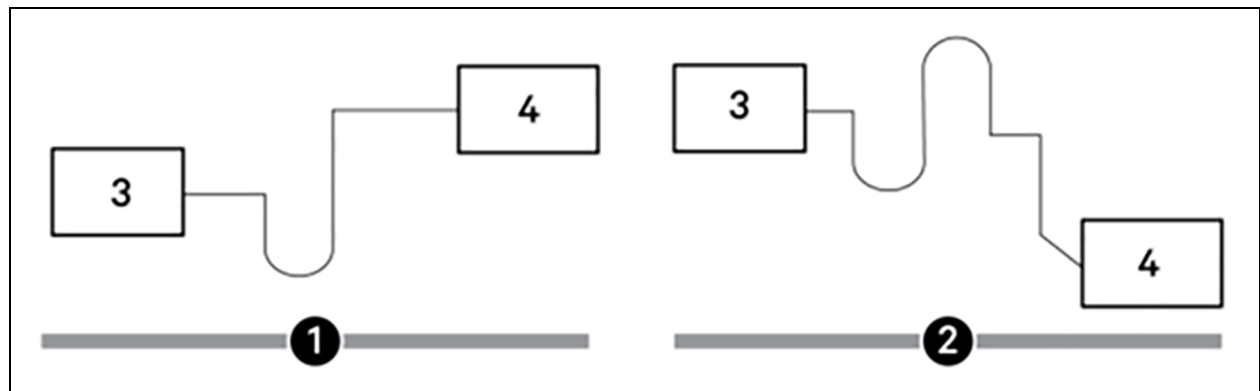

NOTE: Any horizontal pipe must be pitched down toward the condensing unit at a minimum rate of 1/2 in. (13 mm) per 10 ft. (3 m) to assure oil return to compressor.

Item	Description
1	Condensing unit above evaporator
2	Condensing unit below evaporator
3	Evaporator
4	Condensing unit

5.3 Refrigerant Line Sizes and Equivalent Lengths

The following tables list the information required to field install the refrigerant piping for the system.

Table 5.5 Recommended Refrigerant Line Sizes, O.D. cu by Equivalent Length

Equivalent Length, ft (m)	3 Ton		4 Ton		5 Ton	
	Suction	Liquid	Suction	Liquid	Suction	Liquid
50 (15)	7/8	1/2	7/8	1/2	1-1/8	1/2
75 (23)	7/8	1/2	1-1/8	1/2	1-1/8	5/8
100 (30)	7/8	1/2	1-1/8	5/8	1-1/8	5/8
125 (38)	7/8	1/2	1-1/8	5/8	1-1/8	5/8
150 (45)	7/8	1/2	1-1/8	5/8	1-1/8	5/8

Consult factory for proper line sizing for runs longer than maximum equivalent length shown.

1. Use one line size smaller on suction lines for vertical risers.

Source: DPN000788 Rev. 13

5.3.1 Refrigerant Charge Requirements for Water/Glycol-cooled or Air-cooled Systems

To calculate the charge requirements:

1. Determine the charge for your units by model number from the following tables.
2. Determine the charge for the piping by line size and length.
3. Add these all together to obtain the total refrigerant charge for your system.

Table 5.6 Indoor Condenser R-410A Refrigerant Charge

Model #	Charge, lb (kg)
MTC38W	4.2 (1.9)
MTC55W	4.2 (1.9)
MTC69W	4.2 (1.9)
MTC36A	24.9 (11.3)
MTC48A	27 (12.2)
MTC60A	27 (12.2)

Table 5.7 Indoor Evaporator Approximate R-410A Refrigerant Charge

Model #	Charge, lb (kg)
MT036HE/MT036HK	1 (0.45)
MT048HE/MT048HK	2.2 (1.0)
MT060HE/MT060HK	2.2 (1.0)

Table 5.8 Interconnecting Piping Refrigerant Charge for R-410A Using Type L Copper Tube

Line Size, O.D., in.	Liquid Line, lb/100 ft (kg/30 m)	Suction Line, lb/100 ft (kg/30 m)
3/8	3.2 (1.4)	—
1/2	5.9 (2.7)	0.2 (0.1)
5/8	9.6 (4.3)	0.4 (0.2)
3/4	14.3 (6.4)	0.6 (0.3)
7/8	19.8 (8.8)	0.8 (0.4)
1-1/8	33.8 (15.1)	1.4 (0.6)
1-3/8	51.5 (23.0)	2.1 (1.0)

Source: DPN003099 Rev. 1

5.4 Additional Oil Requirements for Scroll Compressors

NOTICE

Risk of improper compressor lubrication. Can cause compressor and refrigerant system damage.

Failure to use oil types, viscosities and quantities recommended by the compressor manufacturer may reduce compressor life and void the compressor warranty. See **Table 5.9** on the facing page for the recommended oil for the system.

- Do not mix polyolester (POE) and mineral-based oils.
- Do not mix oils of different viscosities.
- Consult your Vertiv sales representative, visit <https://www.Vertiv.com/en-us/support/>, or contact the compressor manufacturer if questions arise.

See **Table 5.10** on the facing page, for the amount required for various system charge levels.

In addition to oil added based on system charge, additional oil is required for discharge-line field installed traps. Standard formed tube traps are required, see **Figure 5.2** on the facing page and **Table 5.11** on page 26, because straight tubes and fittings used as traps require much more oil and the length of the straight tube can vary.

With the total calculated refrigerant charge for each circuit, see **Table 5.10** on the facing page for the refrigerant charge amount that was calculated and follow that line to the right to see how much additional compressor oil is required for each circuit. Count the numbers of traps in each circuit. See **Table 5.11** on page 26 for the discharge line pipe diameter. Follow the line to the right to see how much oil is needed per trap. Multiply the number of traps per circuit by the Oil volume. Add the additional compressor oil amount and the trap oil volume together. This will be the total amount of oil that will need to be added before the refrigerant is added to each circuit.

Figure 5.2 Standard Formed Tube Trap Versus Straight Tubes and Fittings Trap

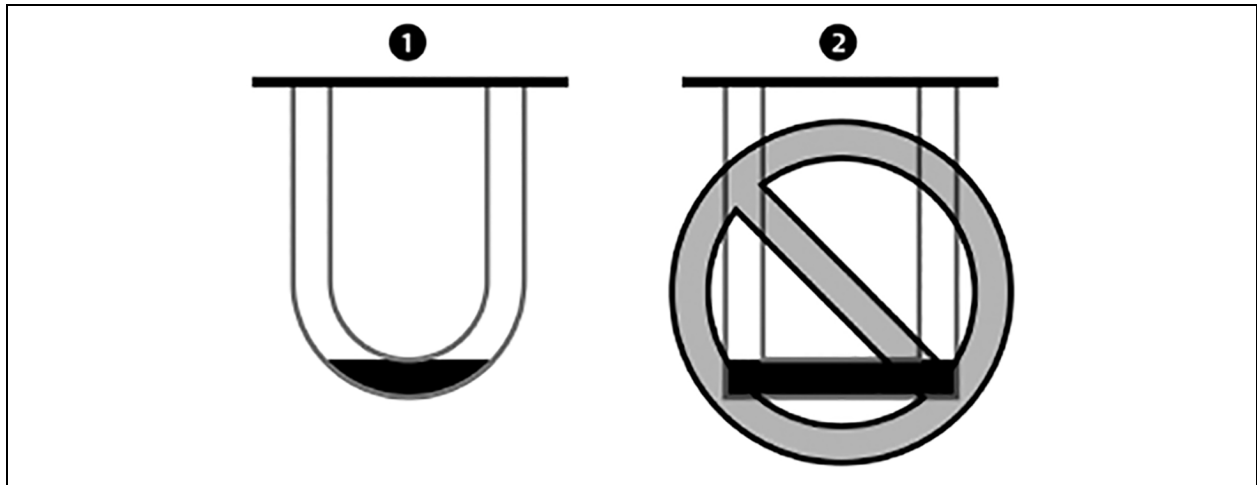

Item	Description
1	Standard formed tube trap
2	Straight tubes and fittings trap

Table 5.9 Compressor Oil types for R-410A Refrigerant

Compressor Type	Oil Type
Copeland Digital Scroll	POE Oil - ISO 32 Centistoke Viscosity ¹
1. Use Copeland POE Oil ULTRA 32-3MAF or other Copeland approved oils. Source: DPN003950 Rev. 5	

Table 5.10 Additional Oil Required per Refrigerant Charge

Refrigerant System Charge per Circuit, lb (kg) *	Models		
	3 Ton	4 Ton	5 Ton
	Additional Oil Required Per Circuit, oz (ml)		
< 40 (18.1)	0	0	0
40 (18.1)	4 (120)	4 (120)	6 (180)
50 (22.7)	6 (180)	6 (180)	9 (270)
60 (27.2)	8 (240)	8 (240)	12 (350)
70 (31.8)	10 (300)	10 (300)	15 (440)
80 (36.3)	12 (350)	12 (350)	18 (530)

* System Charge = indoor unit + condensing unit + refrigerant lines.
For system charges over 80 lb. (36.3 kg), consult your Vertiv representative.

Source: DPN003950 Rev. 6

Table 5.11 Volume of Oil in Standard Form Trap by Pipe Diameter

Pipe diameter, in.	Oil volume, oz (mL)
1/2	0.2 (5.9)
5/8	0.4 (11.8)
3/4	0.6 (17.7)
7/8	0.9 (26.6)
1-1/8	1.8 (53.2)
1-3/8	3.3 (97.6)
1-5/8	5.5 (162.7)
Source: DPN003950 Rev. 6	

5.5 Evacuation, Leak Testing, and Charging for Water/Glycol Systems

5.5.1 Evacuation and Leak Testing Water/Glycol-cooled Systems

For proper leak-check and evacuation, you must open all system valves and account for all check valves, see **Figure 5.3** on the facing page .

Figure 5.3 Valves and Connections for Water/Glycol Condensing Unit

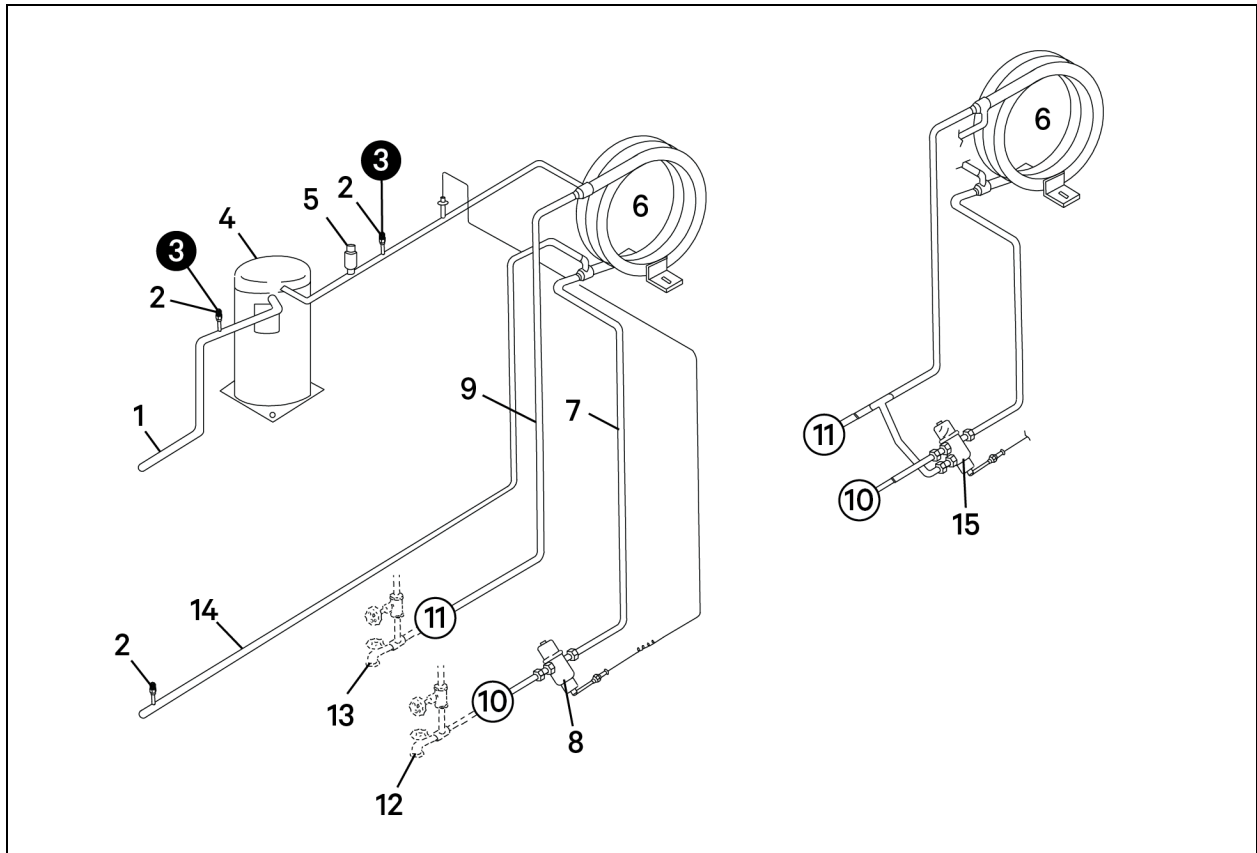

Item	Description
1	Suction line
2	Schrader port with valve core
3	Apply a manifold gauge hose on the suction-line and discharge-line Schrader port.
4	2-stage scroll compressor
5	High-pressure switch
6	Tube-in-tube condenser
7	Water/Glycol supply line
8	2-way water-regulating valve
9	Water/Glycol return line
10	Fluid supply to unit
11	Fluid return from unit
12	Hose bibs (required, field-supplied)

Item	Description
13	Shut-off valves (required, field-supplied)
14	Liquid line
15	3-way water-regulating valve (optional)

To evacuate and leak test the system:

1. Connect a manifold-gauge hose on the discharge- and suction-line Schrader ports, open the service valve, and place a 150 Psig (1034 kPa) charge of dry nitrogen with a tracer of refrigerant, then check the system for leaks with a suitable leak detector.
2. After completion of leak testing, release the test pressure, (observe local code) and pull an initial deep vacuum of 500 microns on the system with a suitable pump.
3. After 4 hours, check the pressure readings and, if they have not changed, break vacuum with dry nitrogen. Pull a second and third vacuum to 500 microns or less. Re-check the pressure after 2 hours.

When the 3 checks are complete, and proceed to [Charging Water/Glycol-cooled Systems](#) below .

5.5.2 Break Vacuum

Using a manifold charging hose equipped with a ball valve, properly connect to a tank of refrigerant, and purge the hose with refrigerant to ensure non-condensables do not enter the system. Connect the hose assembly to the liquid line Schrader port and break circuit vacuum with a portion of the calculated refrigerant pre-charge. Add enough refrigerant to bring pressure slightly above positive. Close ball valve and remove refrigerant tank.

5.5.3 Charging Water/Glycol-cooled Systems



WARNING! Risk of over-pressurization of the refrigeration system. Can cause explosive discharge of high-pressure refrigerant, loss of refrigerant, environmental pollution, equipment damage, injury, or death. This unit contains fluids and gases under high pressure. Use extreme caution when charging the refrigerant system. Do not pressurize the system higher than the design pressure marked on the unit's nameplate. Relieve pressure before cutting into or making connections/disconnections to the piping system. Local building or plumbing codes may require installing a pressure-relief device in the system. Consult local building and plumbing codes for installation requirements of additional pressure-relief devices when isolation valves are field installed. Do not isolate any refrigerant circuit from over-pressurization protection.



CAUTION: Risk of excessive refrigerant line pressure. Can cause tubing and component rupture resulting in equipment damage and personal injury. Do not close off refrigerant-line isolation valve for repairs unless a pressure-relief valve is field- installed in the line between the isolation valve and the check valve. The pressure-relief valve must be rated 5% to 10% higher than the system-design pressure. An increase in ambient temperature can cause the pressure of the isolated refrigerant to rise and exceed the system-design pressure rating (marked on the unit nameplate).



CAUTION: Risk of contacting caustic substances. Can cause injury. Avoid touching or contacting the gas and oils with exposed skin. Severe burns will result. Wear appropriate, OSHA-approved PPE when handling contaminated parts.

NOTICE

Risk of improper refrigerant charging. Can cause equipment damage.

R-410A is a blended refrigerant and must be introduced and charged from the cylinder only as a liquid.

Care must be exercised to avoid damage to the compressor. We recommend connecting a manifold charging hose equipped with a ball valve to the liquid line Schraeder port.

NOTICE

Units should never be operated with no refrigerant charge, holding charge, proper load, or without additional oil as required. Tag out system to prevent unauthorized personnel from accidentally starting equipment and damaging compressors if any of these conditions exist.

To calculate the charge for the system:

1. Check the nameplate on the indoor unit for refrigerant type to use.
2. Refer to [Refrigerant Charge Requirements for Water/Glycol-cooled or Air-cooled Systems](#) on page 23, and calculate the amount of charge for the system including the evaporator, condensing unit, and interconnecting piping.
3. Add additional compressor and trap oil, see [Additional Oil Requirements for Scroll Compressors](#) on page 24.
4. Accurately weigh-in as much of the system charge as possible before starting the unit.

NOTICE

The unit must have line voltage applied to the unit at least 12 hours before compressor start-up to allow the compressor crankcase heaters time to warm the compressors and boil off any liquid refrigerant in the compressors after pre-charge.

Apply manifold gauges to suction and discharge service valves on circuit 1. Open Service valves on compressor.

5.5.4 Optimizing Refrigerant Charge on Water/Glycol Units

1. Operate the unit at full heat load, normal room conditions and normal water/glycol fluid temperatures for a minimum of 30 minutes before measuring stable unit superheat and subcooling temperatures and adjusting charge levels.
 - Condensing temperatures should be in range of 100 to 130°F (38 to 54°C) depending on fluid type and fluid temperature.
 - Full heat load is required to stabilize the system.
2. Attach pressure and temperature instruments to the liquid line of the condensing unit. Measure the initial subcooling.

NOTE: To determine subcooling measurement, a liquid-line pressure reading (at the factory-installed Schrader tap) must be measured along with the temperature reading on the liquid line. Convert the liquid-line pressure reading into a liquid temperature by utilizing a Pressure-temperature Guide. Subtract the measured temperature from the liquid-saturation temperature. The difference is subcooling.

3. Adjust refrigerant charge levels as needed to achieve subcooling range of 8 to 10°F (4.4 to 5.5°C) while maintaining full load conditions.
4. Additional Compressor Oil: Once the circuits are topped off with refrigerant, more compressor oil may need to be added to each circuit if the final charge is over 10 pounds of the calculated refrigerant charge. Record this additional oil amount on the manilla tag hanging on the compressor service valve.

5.5.5 Documenting Refrigerant Charge on Water/Glycol-cooled Units

When the unit is charged, you must record the total system charge value on the condensing unit's serial tag. The total system charge includes the evaporator, condensing unit, and interconnecting lines.

5.6 Evacuation, Leak Testing, and Charging for Air Cooled Systems

5.6.1 Evacuation and Leak Testing Air-cooled Systems

For proper leak-check and evacuation, you must open all system valves and account for all check valves, see **Figure 5.4** below .

Figure 5.4 Valves and Connections for Air-cooled Condensing Unit

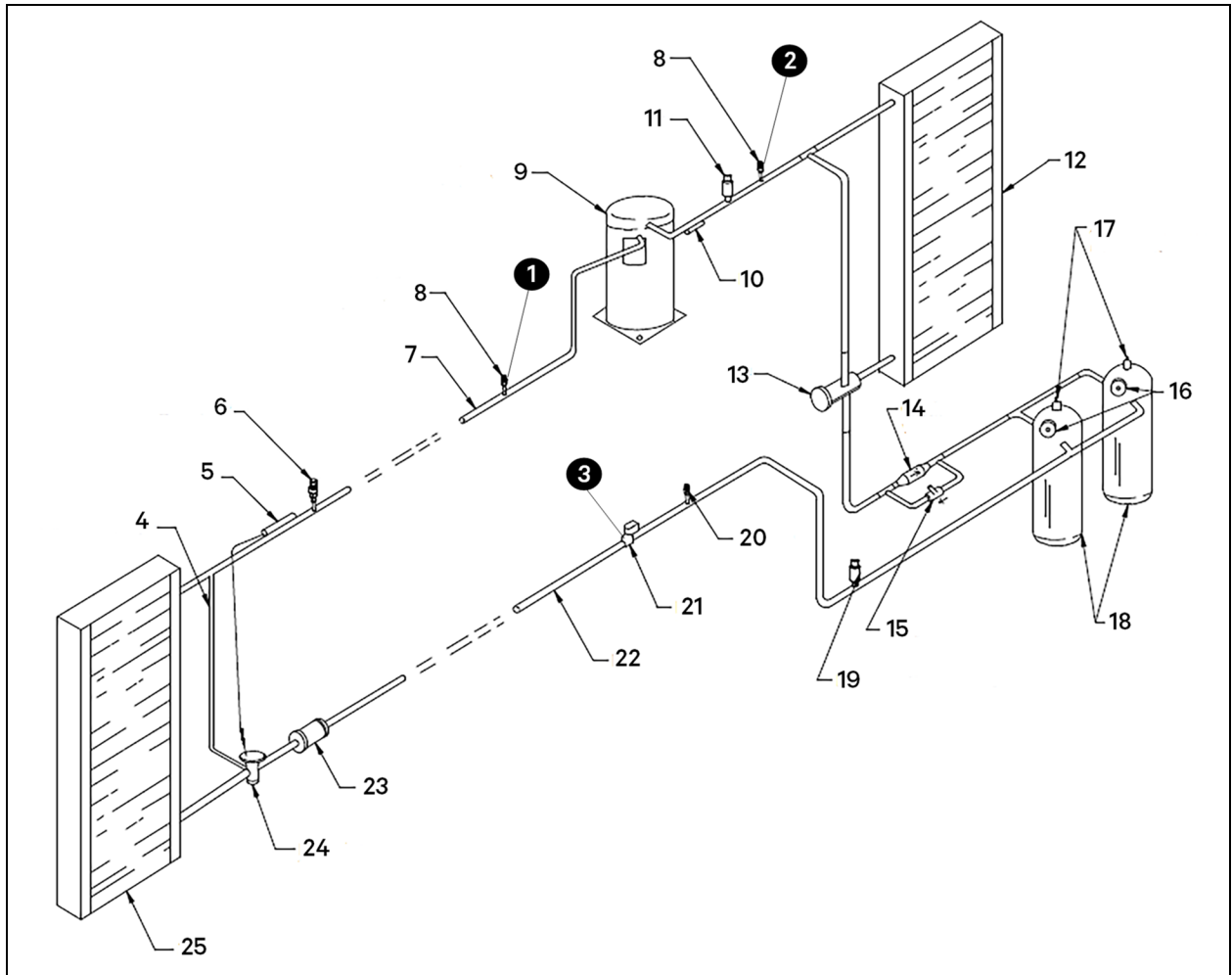

Item	Description
1	Apply a manifold gauge hose on the suction-line Schrader port.
2	Apply a manifold gauge hose on the discharge-line Schrader port.
3	Remove the solenoid-valve holding coil then apply solenoid-valve service magnet to the valve.
4	External equalizer
5	Sensing bulb
6	Suction-pressure transducer
7	Suction line
8	Schrader port with valve core
9	Digital scroll compressor
10	Discharge-temperature thermistor
11	High pressure switch
12	Condenser coil
13	3-way head-pressure control valve
14	Check valve
15	Pressure-balancing valve
16	Sight glass
17	Pressure-relief valve
18	Liebert® Lee-Temp receiver
19	Receiver-heater pressure-limiting switch
20	Schrader port with valve core NOTE: The system includes a factory-installed Schrader valve with core in the liquid line downstream of the receiver. Proper evacuation of the condenser side of the system can be accomplished only using the downstream Schrader valve. See the appropriate piping schematic for your system in Submittal Drawings on page 47 .
21	Liquid-line solenoid valve
22	Liquid line
23	Filter drier
24	Expansion valve
25	Evaporator coil

To evacuate and leak test the system:

1. Open the liquid-line solenoid valve by removing the holding coil, and apply a solenoid-valve service magnet to the valve.
2. Connect manifold-gauge hoses on the discharge- and suction-line Schrader ports, open the service valves, and place a 150 PSIG (1034 kPa) charge of dry nitrogen with a tracer of refrigerant, then check the system for leaks with a suitable leak detector.
3. After completion of leak testing, release the test pressure, (observe local code) and pull an initial deep vacuum of 500 microns on the system with a suitable pump.
4. After 4 hours, check the pressure readings and, if they have not changed, break vacuum with dry nitrogen. Pull a second and third vacuum to 500 microns or less. Re-check the pressure after 2 hours.
5. When the 3 checks are complete, proceed to [Charging Air-cooled Systems](#) below .

5.6.2 Break Vacuum

Using a manifold charging hose equipped with a ball valve, properly connect to a tank of refrigerant, and purge the hose with refrigerant to ensure non-condensables do not enter the system. Connect the hose assembly to the liquid line Schrader port and break circuit vacuum with a portion of the calculated refrigerant pre-charge. Add enough refrigerant to bring pressure slightly above positive. Close ball valve and remove refrigerant tank.

5.6.3 Charging Air-cooled Systems

NOTICE

Risk of improper refrigerant charging. Can cause equipment damage.

R-410A is a blended refrigerant and must be introduced and charged from the cylinder only as a liquid.

Care must be exercised to avoid damage to the compressor. We recommend connecting a manifold charging hose equipped with a ball valve to the liquid line Schraeder port.

NOTICE

Risk of improper component re-installation. Can cause equipment damage.

Identify and mark location of the discharge pressure switch. It must be reinstalled in its original location.

NOTICE

Units should never be operated with no refrigerant charge, holding charge, proper load, or without additional oil as required. Tag out system to prevent unauthorized personnel from accidentally starting equipment and damaging compressors if any of these conditions exist.

Initially charging the system:

- Check the nameplate on the indoor unit for refrigerant type to use.
- Refer to [Refrigerant Charge Requirements for Water/Glycol-cooled or Air-cooled Systems](#) on page 23, and calculate the amount of charge for the system including the evaporator, condensing unit, and interconnecting piping.
- Add additional compressor and trap oil, see [Additional Oil Requirements for Scroll Compressors](#) on page 24.
- Accurately weigh-in as much of the system charge as possible before re-installing the coil on the liquid-line solenoid valve and starting the unit.

NOTICE

The unit must have line voltage applied to the unit at least 12 hours before compressor start-up to allow the compressor crankcase heaters time to warm the compressors and boil off any liquid refrigerant in the compressors after pre-charge.

Field Charge Verification

The unit receiver includes an integral sight glass to assist with charge verification in the field.

To verify the refrigerant charge:

1. To keep the unit operating, use the Service menu at the Vertiv™ Liebert® iCOM™ touchscreen control:
 - Touch the Service icon to display the service menu, then touch Diagnostics/Service.
 - Touch the Compressor Circuit options, and select 2 (charge mode) in the Compressor Mode field.

The compressor runs at 100% for 30 minutes in charge mode.
2. At design ambient temperature between 95°F and 105°F (35°C and 41°C), the charge level should be in the middle of the sight glass.
 - If the charge level is below the sight glass, an under-charge condition is likely.
 - If the charge level is above the sight glass, and you observe a higher than normal discharge pressure, an over-charge condition is likely. However, before removing charge, make sure that there are no other possible causes of high discharge pressure such as a dirty coil or restricted air flow.
3. Below design ambient temperatures, refrigerant backs-up into the condenser coil and the charge level drops below the sight glass. At lower ambient temperatures, block the condenser coil to maintain 418 psig (2882 kPa) discharge pressure to ensure that the head-pressure control valve is closed. The charge level should be in the middle of the sight glass with the valve closed.
 - If the charge level is below the sight glass, an under-charge condition is likely.
 - If the charge level is above the sight glass, an over-charge condition is likely.

5.6.4 Additional Compressor Oil

Once the circuits are topped off with refrigerant, more compressor oil may need to be added to each circuit if the final charge is over 10 pounds of the calculated refrigerant charge. Record this additional oil amount on the manilla tag hanging on the compressor service valve.

5.6.5 Documenting Refrigerant Charge and Oil Addition

When the unit is charged, you must record the total system refrigerant charge value on the condensing unit's serial tag. The total system charge includes the evaporator, condensing unit, and interconnecting lines, plus any adjustments made during the field-charge verification step.

On the tag marked "Oil Added Field Service Record," attached to each compressor, record the date the oil was added and the amount of oil added.

6 Electrical Connection Requirements



WARNING! Arc flash and electric shock hazard. Open all local and remote electric power-supply disconnect switches, verify with a voltmeter that power is Off and wear appropriate, OSHA-approved personal protective equipment (PPE) per NFPA 70E before working within the electric control enclosure. Failure to comply can cause serious injury or death. Customer must provide earth ground to unit, per NEC, CEC and local codes, as applicable. Before proceeding with installation, read all instructions, verify that all the parts are included and check the nameplate to be sure the voltage matches available utility power. The Vertiv™ Liebert® iCOM™ controller does not isolate power from the unit, even in the “Unit Off” mode. Some internal components require and receive power even during the “Unit Off” mode of the Liebert™ iCOM™ controller. The only way to ensure that there is NO voltage inside the unit is to install and open a remote disconnect switch. Refer to unit electrical schematic. Follow all local codes.



WARNING! Risk of improper wire sizing/rating and loose electrical connections. Can cause overheated wire and electrical connection terminals resulting in smoke, fire, equipment and building damage, injury or death. Use correctly sized copper wire only and verify that all electrical connections are tight before turning power On. Check all electrical connections periodically and tighten as necessary.

NOTICE

Risk of improper electrical connection of three-phase input power. Can cause backward compressor rotation and unit damage. Service technicians should use a gauge set on the system during the initial start up to verify that the three-phase power is connected properly. Three-phase power must be connected to the unit line voltage terminals in the proper sequence so that the compressors rotate in the proper direction. Incoming power must be properly phased to prevent compressors from running backward. We recommend checking the unit's phasing with proper instrumentation to ensure that power connections were made correctly. We also recommend verifying discharge and suction pressures during start up to ensure that the compressors are running in the correct direction.

NOTICE

Risk of compressor slugging. Can cause equipment damage.

Apply power to the unit for 8 hours before operating the system. This time is required to drive liquid refrigerant out of the compressor. This is especially important at low ambient temperatures. The compressor's crank-case heater is energized as long as power is supplied to the unit.

Risk of improper power-supply connection. Can cause equipment damage and loss of warranty coverage.

Prior to connecting any equipment to a main or alternate power source (for example: back-up generator systems) for start-up, commissioning, testing, or normal operation, ensure that these sources are correctly adjusted to the nameplate voltage and frequency of all equipment to be connected. In general, power-source voltages should be stabilized and regulated to within $\pm 10\%$ of the load nameplate nominal voltage. Also, ensure that no three-phase sources are single-phased at any time.

See transformer label for primary tap connections. Installer will need to change transformer primary taps if applied unit voltage is other than pre-wired tap voltage.

Electrical service is required for all models. All power and control wiring and ground connections must be in accordance with the National Electrical Code and local codes. Refer to the equipment serial-tag data for electrical requirements.

A field-supplied, manual, electrical-disconnect switch should be installed in accordance with local codes and distribution system. Consult local codes for external disconnect requirements.

NOTE: Input-power requirements: For 3-phase units, only 3 power wires and an earth ground are required.

Each unit is shipped from the factory with internal wiring completed. Refer to the electrical schematic when making connections.

The electrical connections are described in the submittal documents included in the [Submittal Drawings](#) on page 47 .

The following table lists the relevant documents by number and title.

Table 6.1 Electrical Field Connection Drawings

Document Number	Title
DPN004895	Electrical Field Connections, water/glycol-cooled
DPN004972	Connection locations, water/glycol-cooled
10030173	Electrical Field Connections, 3, 4, and 5 Ton Air Cooled Condensing Unit
10030336	Primary Connection Locations, 3, 4, and 5 Ton Air Cooled Condensing Unit

6.1 Low Voltage, Control Connections

Control wiring must be installed in accordance with the National Electrical Code (NEC) Class 1 or Class 2 circuit according to wire-routing conditions chosen and local codes.

Low voltage wiring should be sized to allow a 1-Volt maximum drop due to line resistance between the evaporator and condensing unit. Use NEC Class 1 or 2 wiring according to wire routing conditions chosen and local codes, sizing wire per maximum wire lengths using **Table 6.2** below . Connect the shield wire to earth (ground) at the Liebert® equipment. Avoid running the low-voltage connections near high-voltage lines or loads such as light ballasts.

NOTE: Do not connect additional electrical devices to the control circuit. The internal control transformer is only sized for factory-supplied components. Refer to the appropriate submittal drawings for your system for electrical connections. See **Table 6.1 above .**

Table 6.2 Recommended Minimum Wire Size Between Indoor and Outdoor Units

Max. Distance, * ft (m)	Min. Wire Gauge, AWG (mm2)
50 (15)	20 (0.75)
100 (30)	18 (1.0)
150 (45)	16 (1.5)
* One-way control wire run between outdoor condensing unit and evaporator.	

6.1.1 Water/Glycol-cooled Condensing Unit Control Connections

A field-supplied, shielded, 4-wire control connection (24 VAC) is required between the evaporator and the condensing unit.

Glycol-cooled units require an additional field-supplied, 2-conductor (thermostat type) wire connection between the evaporator unit and the condensing unit. Units with water-tower loops can be wired for circulation pump/valve requirement. A Class 1 circuit is required for Water/Glycol units. Control wiring must be installed in accordance with NEC and local codes. Refer to the appropriate submittal drawings for electrical connections. See **Table 6.1** on the previous page .

6.1.2 Air-cooled Condensing Unit Control Connections

A field-supplied, shielded, 6-wire control connection (24 VAC) is required between the evaporator and the condensing unit.

This page intentionally left blank

7 Maintenance



WARNING! Arc flash and electric shock hazard. Open all local and remote electric power-supply disconnect switches, verify with a voltmeter that power is Off and wear appropriate, OSHA-approved personal protective equipment (PPE) per NFPA 70E before working within the electric control enclosure. Failure to comply can cause serious injury or death. Customer must provide earth ground to unit, per NEC, CEC and local codes, as applicable. Before proceeding with installation, read all instructions, verify that all the parts are included and check the nameplate to be sure the voltage matches available utility power. The Vertiv™ Liebert® iCOM™ controller does not isolate power from the unit, even in the “Unit Off” mode. Some internal components require and receive power even during the “Unit Off” mode of the Liebert® iCOM™ controller. The only way to ensure that there is NO voltage inside the unit is to install and open a remote disconnect switch. Refer to unit electrical schematic. Follow all local codes.



WARNING! Risk of electric shock. Can cause equipment damage, injury or death. Open all local and remote electric power supply disconnect switches and verify with a voltmeter that power is off before working within any electric connection enclosures. Service and maintenance work must be performed only by properly trained and qualified personnel and in accordance with applicable regulations and manufacturers’ specifications. Opening or removing the covers to any equipment may expose personnel to lethal voltages within the unit even when it is apparently not operating and the input wiring is disconnected from the electrical source.



WARNING! Risk of electric shock. Can cause serious injury or death. The Liebert® iCOM™ microprocessor does not isolate power from the unit, even in the "Unit Off" mode. Some internal components require and receive power even during the "unit off" mode of the Liebert® iCOM™ control. Open all local and remote electric power disconnect switches and verify with a voltmeter that power is Off before working on any component of the system.



WARNING! Risk of improper wiring, piping, moving, lifting and handling. Can cause equipment damage, serious injury or death. Installation and service of this equipment should be done only by qualified personnel who have been specially-trained in the installation of air-conditioning equipment and who are wearing appropriate, OSHA-approved PPE.



WARNING! Risk of contact with high speed, rotating fan blades. Can cause injury or death. Open all local and remote electric power supply disconnect switches, verify with a voltmeter that power is off, and verify that all fan blades have stopped rotating before working in the unit cabinet.



CAUTION: Risk of contact with hot surfaces. Can cause injury. The compressor, refrigerant-discharge lines, and some electrical components are extremely hot during unit operation. Allow sufficient time for them to cool to a touch-safe temperature before working within the unit cabinet. Use extreme caution and wear appropriate, OSHA-approved PPE when working on or near hot components.

The Vertiv™ Liebert® Water/Glycol and Air-cooled Condensing Units are single components in the facility heat-removal system. The system includes evaporator, air distribution (duct systems), indoor heat rejection (condensing unit) and indoor cooling and humidity loads (equipment load, location, outside air infiltration). Proper application and maintenance of the entire system is critical to the life and reliability of the thermal-management units.

- Good maintenance practices are essential to minimizing operation costs and maximizing product life.
- Read and follow monthly and semi-annual maintenance schedules included in this manual. These MINIMUM maintenance intervals may need to be more frequent based on site-specific conditions.
- See the Vertiv™ Liebert® iCOM™ user manual for instructions on using the controller to predict some service maintenance intervals.
- We recommend the use of trained and authorized service personnel, extended service contracts and factory-specified replacement parts. Contact your Vertiv sales representative.

7.1 Coaxial Condenser Maintenance

Each water or glycol-cooled module has a coaxial condenser consisting of an exterior steel tube and an interior copper tube. Clean the screen on the field-supplied Y-strainer (if installed). If the water supply is clean, coaxial condensers do not normally require maintenance or replacement. If your system begins to operate at high head pressure with reduced capacity and all other causes have been eliminated, the condenser may be obstructed or fouled and should be cleaned or replaced.

7.2 Regulating Valve Maintenance

The water-regulating valve automatically regulates the amount of fluid necessary to remove the heat from the refrigeration system, permitting more fluid to flow when load conditions are high and less fluid to flow when load conditions are low. The valve consists of a brass body, balance spring, valve seat, valve disc holders, capillary tube to discharge pressure and adjusting screw.

The water regulating valve begins opening at 295 psig (2034 kPag) and is fully opened at 350 psig (2413 kPag). The valve is factory-set and should not need adjustment. Consult Vertiv technical support before making any adjustments.

7.3 Glycol Solution Maintenance

It is difficult to establish a specific schedule of inhibitor maintenance because the rate of inhibitor depletion depends upon local water conditions. Analysis of water samples at the time of installation and through a maintenance program should help to establish a pattern of depletion. A visual inspection of the solution and filter residue is often helpful in judging whether active corrosion is occurring.

The complexity of water/glycol solution condition problems and the variations of required treatment programs make it extremely important to obtain the advice of a competent and experienced water-treatment specialist and follow a regularly-scheduled coolant-fluid system-maintenance program. It is important to note that improper use of water treatment chemicals can cause problems more serious than using none. Proper inhibitor maintenance must be performed in order to prevent corrosion of the glycol system. Consult the glycol manufacturer for testing and maintenance of inhibitors. Do not mix products from different manufacturers.

7.4 Facility Fluid and Piping Maintenance for Water and Glycol Systems

Maintaining the system fluid quality is required throughout the life of the system. Fluid and piping system maintenance schedules must be established and performed. A coolant-fluid maintenance program must be established that will evaluate fluid chemistry and apply necessary treatment. The complexity of water/glycol solution condition problems and the variations of required treatment programs make it extremely important to obtain the advice of a competent and experienced water-treatment specialist and follow a regularly-scheduled coolant-fluid system-maintenance program.

Perform periodic inspections of the facility and heat exchanger and coolant-fluid piping system for leaks and visible damage.

7.5 Compressor Maintenance



WARNING! Arc flash and electric shock hazard. Open all local and remote electric power disconnect switches, verify with a voltmeter that power is Off and wear personal protective equipment (PPE) per NFPA 70E before working within the electric control enclosure. Failure to comply can cause serious injury or death. The Vertiv™ Liebert® iCOM™ controller does not isolate power from the unit, even in the “Unit Off” mode. Some internal components require and receive power even during the “Unit Off” mode of the Liebert® iCOM™ controller. The only way to ensure that there is NO voltage inside the unit is to install and open a remote disconnect switch. Refer to unit electrical schematic. Follow all local codes.

NOTICE

Risk of compressor slugging. Can cause equipment damage. Apply power to the condensing unit 8 hours before operating the system. This time is required to drive liquid refrigerant out of the compressor. This is especially important at low ambient temperatures. The compressor's crank-case heater is energized as long as power is supplied to the unit.

Access the condensing unit by removing the unit housing panel.

- Clean the air cooled condenser coil of all debris that will inhibit airflow. This can be done with compressed air, with water from a garden hose, or with a commercial coil cleaner.
- Check for bent or damaged coil fins and repair as necessary.
- During winter, do not permit snow to accumulate on or around the condensing unit.
- Check all refrigerant lines and capillaries for vibration isolation and support as necessary.
- Check all refrigerant lines for signs of leaks.

7.5.1 Compressor Oil

NOTICE

Risk of improper compressor lubrication. Can cause compressor and refrigerant system damage.

Failure to use oil types, viscosities and quantities recommended by the compressor manufacturer may reduce compressor life and void the compressor warranty.

- Do not mix polyolester (POE) and mineral-based oils.
- Do not mix oils of different viscosities.
- Consult Vertiv technical support or the compressor manufacturer if questions arise.

Table 7.1 Compressor Oil Types for R-410A Refrigerant

Compressor Type	Oil Type
Copeland Scroll and Digital Scroll	POE Oil - ISO 32 Centistoke Viscosity ¹
1. Use Copeland POE Oil ULTRA 32-3MAF or other Copeland-approved oils. Source: DPN003950 Rev.5	

7.5.2 Replacement Compressors

Replacement compressors are available through your Vertiv sales office. If the unit is under warranty, the replacement compressor must be obtained from and the original compressor returned to your local Vertiv sales office. Compressors are shipped in reusable packaging, and the original compressor should be returned in the same packaging.

7.5.3 Compressor Motor Burnout

If a burnout has occurred, a full system clean-out is required. If not cleaned, compressor and system problems will continue. Consult the factory for compressor maintenance. Do not attempt to remove the compressor without first contacting Vertiv support at 1-800-543-2778.

7.5.4 Unloading Solenoid(s) on a Digital Scroll Compressor

When replacing a digital-scroll compressor, the digital solenoid valve and coil must be replaced. The compressor and valve kit are shipped separately. The valve kit must be field-brazed to the top of the compressor in proper orientation and supported with the original factory bracket.

7.5.5 Replacing the Compressor



WARNING! Risk of electric shock. Can cause serious injury or death. The Vertiv™ Liebert® iCOM™ microprocessor does not isolate power from the unit, even in the "Unit Off" mode. Some internal components require and receive power even during the "unit off" mode of the Liebert® iCOM™ control. Open all local and remote electric power disconnect switches and verify with a voltmeter that power is Off before working on any component of the system.



WARNING! Risk of over-pressurization of the refrigeration system. Can cause explosive discharge of high-pressure refrigerant, loss of refrigerant, environmental pollution, equipment damage, injury, or death. This unit contains fluids and gases under high pressure. Use extreme caution when charging the refrigerant system. Do not pressurize the system higher than the design pressure marked on the unit's nameplate. Relieve pressure before cutting into or making connections/disconnections to the piping system. Do not close off any field-installed, refrigerant-line isolation valves for repairs unless a pressure-relief valve is field-installed in the line between the isolation valve and the check valve. The pressure-relief valve must be rated 5% to 10% higher than the system-design pressure. An increase in ambient temperature can cause the pressure of the isolated refrigerant to rise and exceed the system-design pressure rating (marked on the unit nameplate).

NOTICE

Risk of improper component re-installation. Can cause equipment damage.

Identify and mark location of the discharge pressure switch. It must be reinstalled in its original location.

NOTE: Failure to properly clean the system after compressor-motor burnout voids the compressor warranty. Follow the manufacturer's procedure.

NOTE: Release of refrigerant to the atmosphere is harmful to the environment. Refrigerant must be recycled or discarded in accordance with federal, state and local regulations.

1. Disconnect power.
2. Attach suction and discharge gauges to access fittings.
3. Recover refrigerant using an approved recovery procedure and equipment. Use a filter drier when charging the system with recovered refrigerant.
4. Remove the temperature thermistor from the discharge line and make a note of its location because you will need to re install it.
5. Unsweat refrigerant connections and disconnect all electrical connections.
6. Remove failed compressor.
7. Install replacement compressor and make all connections.
8. Re-install the temperature thermistor at its original location (noted in step 4), which is within 6 inches of the compressor connection, and insulate making sure that the bulb makes good contact with the discharge line.
9. Pressurize and leak-test the system.
10. Follow compressor manufacturer's suggested clean-out procedures.
11. After completion of leak testing, release the test pressure, (observe local code) and pull an initial deep vacuum of 500 microns on the system with a suitable pump.
12. After 4 hours, check the pressure readings and, if they have not changed, break vacuum with dry nitrogen. Pull a second and third vacuum to 500 microns or less, and verify that the vacuum levels are maintained.
13. With the system in a 500 micron or lower vacuum, charge the system based on the requirements listed in [Refrigerant Charge Requirements for Water/Glycol-cooled or Air-cooled Systems](#) on page 23 .

7.6 Blower Package Maintenance

Inspect the blower package monthly including: motor mounts, belts (if applicable), fan bearings, and impellers.

7.6.1 Fan Impeller and Motor Bearing Maintenance

Inspect fan impellers thoroughly and remove any debris. Check to see if the impellers are tightly mounted on the fan shaft and that they do not rub against the fan housing during rotation. Although the unit's motor bearings are permanently sealed and self-lubricating, inspect them monthly for signs of wear.

7.6.2 Air Distribution Inspection

Because all unit models are designed for constant volume air delivery, any unusual restrictions within the air circuit must be avoided. Note that high efficiency filters can reduce air performance and evaporator capacity.

This page intentionally left blank

Appendices

Appendix A: Technical Support and Contacts

A.1 Technical Support/Service in the United States

Vertiv Group Corporation

24x7 dispatch of technicians for all products.

1-800-543-2378

Liebert® Thermal Management Products

1-800-543-2378

Liebert® Channel Products

1-800-222-5877

Liebert® AC and DC Power Products

1-800-543-2378

A.2 Locations

United States

Vertiv Headquarters

505 N. Cleveland Ave.

Westerville, OH 43082, USA

Europe

Via Leonardo Da Vinci 8 Zona Industriale Tognana

35028 Piove Di Sacco (PD) Italy

Asia

7/F, Dah Sing Financial Centre

3108 Gloucester Road

Wanchai, Hong Kong

This page intentionally left blank

Appendix B: Submittal Drawings

The submittal drawings are in the order of document part number (DPN). **Table B.1** below, groups the drawings by topic/application.

Table B.1 Submittal Drawings Contents

Document Number	Title
Component Locations	
DPN004989	Component location diagram 3, 4, and 5 Ton Water/Glycol-cooled condensing unit
10031570	Component location diagram 3, 4, and 5 Ton Air-cooled condensing unit
Planning Dimensions	
DPN004889	Cabinet dimensions, 3, 4, and 5 Ton, Water/Glycol-cooled
10030172	Cabinet dimensions, 3, 4, and 5 Ton Air-cooled condensing unit
Piping Schematics	
DPN004893	Piping arrangement, Water/Glycol-cooled condensing unit
10030175	General arrangement 3, 4, and 5 Ton Air-cooled condensing unit
Piping and Electrical Connections	
DPN004972	Primary connection locations, Water/Glycol-cooled
10030336	Primary connection locations, 3, 4, and 5 Ton Air-cooled Condensing Unit
Electrical Connections	
DPN004895	Electrical Field Connections, Water/Glycol-cooled
10030173	Electrical Field Connections, 3, 4, and 5 Ton Air-cooled Condensing Unit

COMPONENT LOCATION DIAGRAM

3/4/5 TON WATER/GLYCOL COOLED INDOOR CONDENSING UNIT

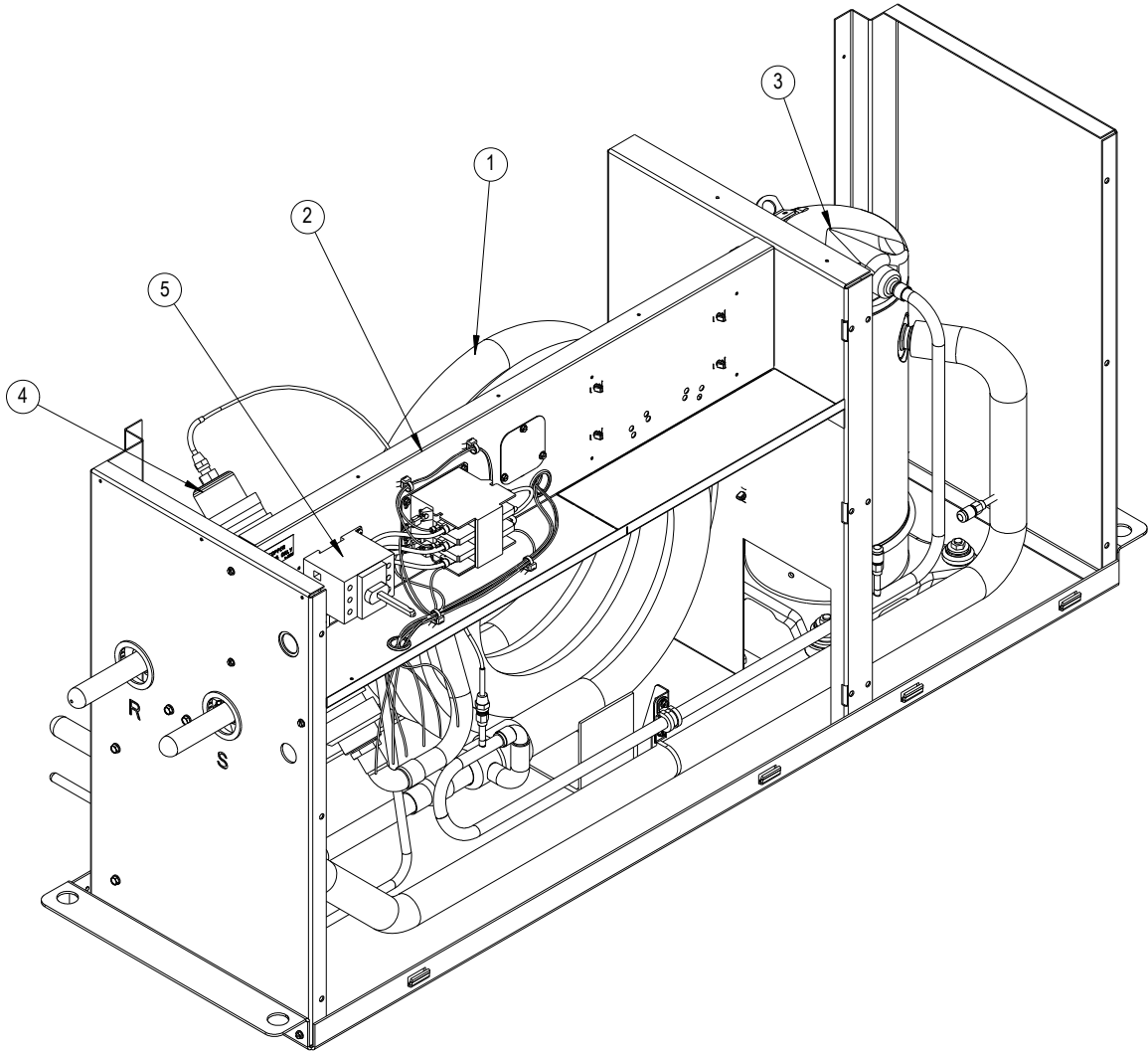

1. Condenser coil
2. Electric box
3. Scroll Compressor
4. Water Regulating Valve
5. Disconnect switch

COMPONENT LOCATION DIAGRAM 3 TON AIR COOLED CONDENSING UNIT

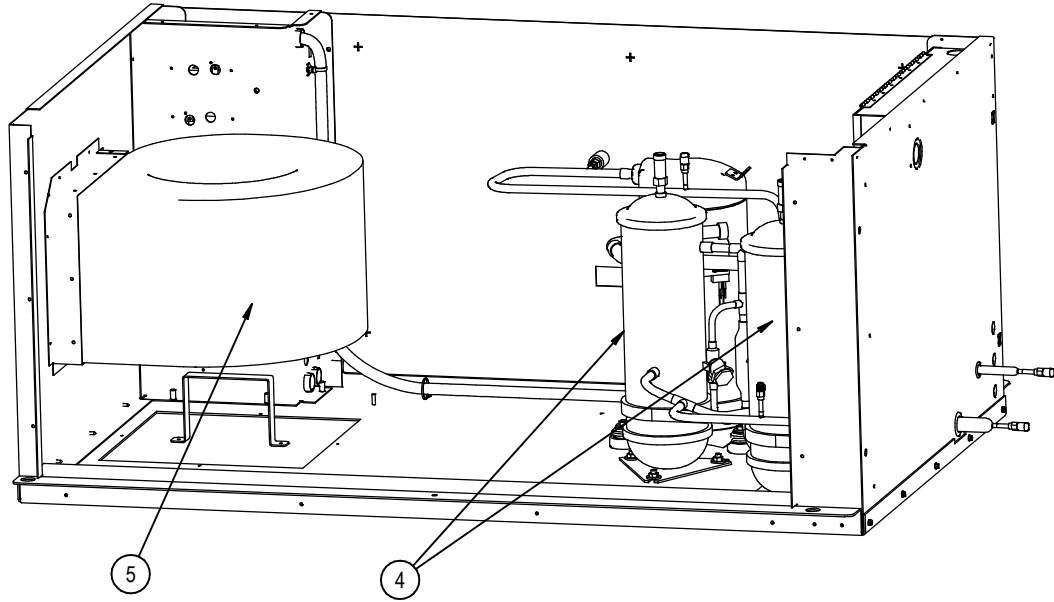

- 1. Electrical Box
- 2. Condenser Coil
- 3. Compressor
- 4. Receiver
- 5. Direct Drive Blower

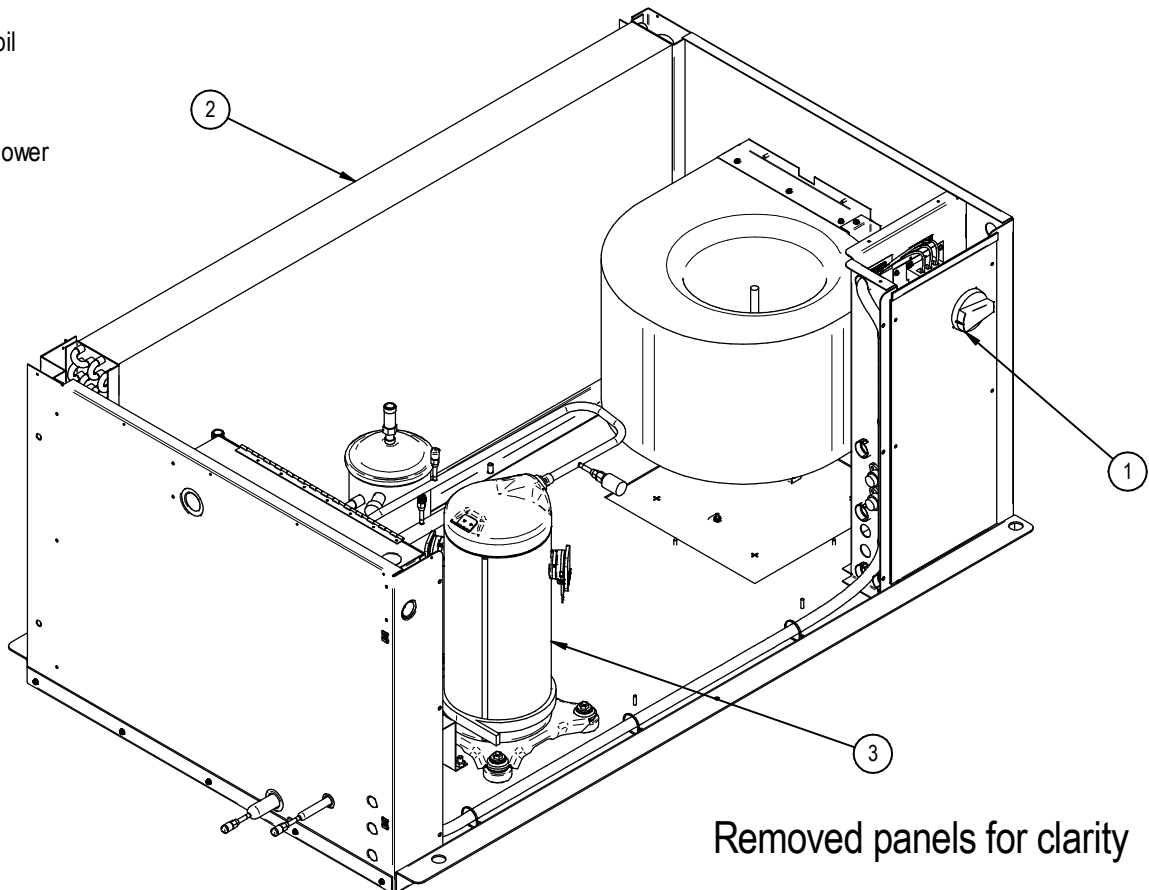

COMPONENT LOCATION DIAGRAM 4-5 TON AIR COOLED CONDENSING UNIT

- 1. Electrical Box
- 2. Condenser Coil
- 3. Compressor
- 4. Receiver
- 5. Blower
- 6. Fan Pulley
- 7. Motor Sheave and Belts

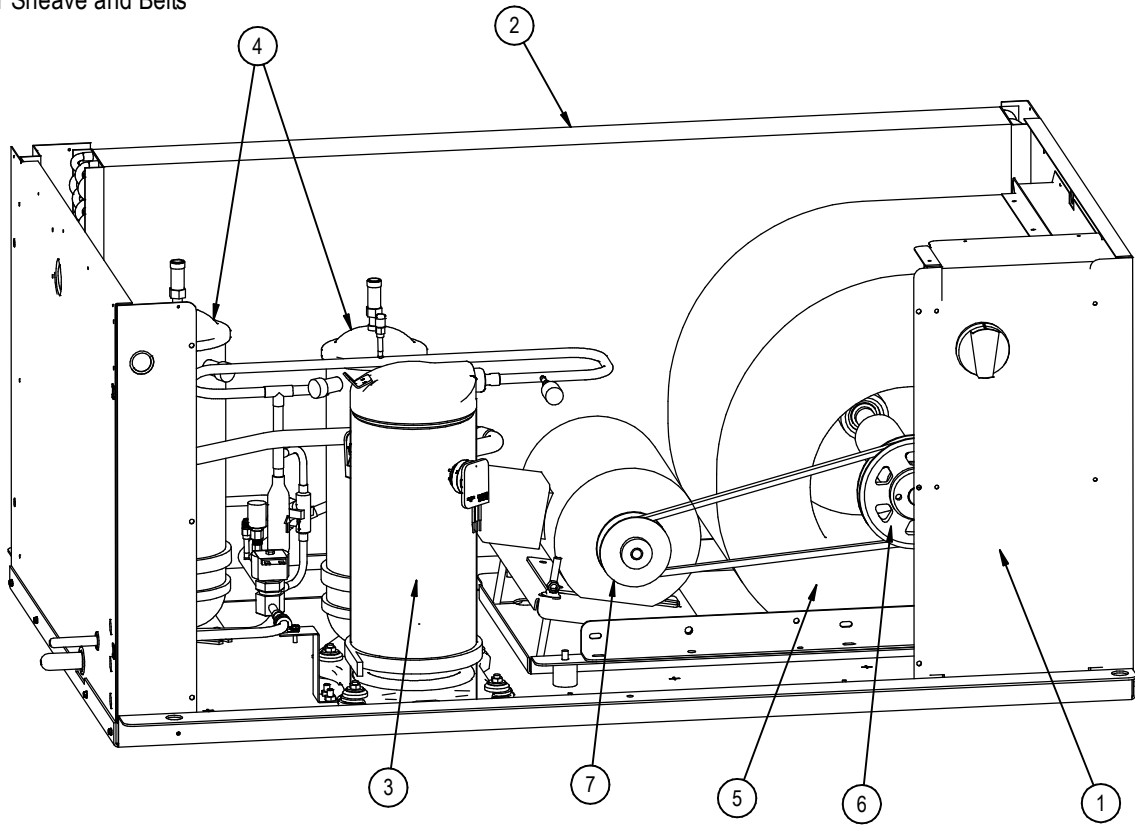

Removed panels for clarity



LIEBERT® MTC

CABINET DIMENSIONAL DATA

3/4/5 TON WATER/GLYCOL COOLED INDOOR CONDENSING UNIT

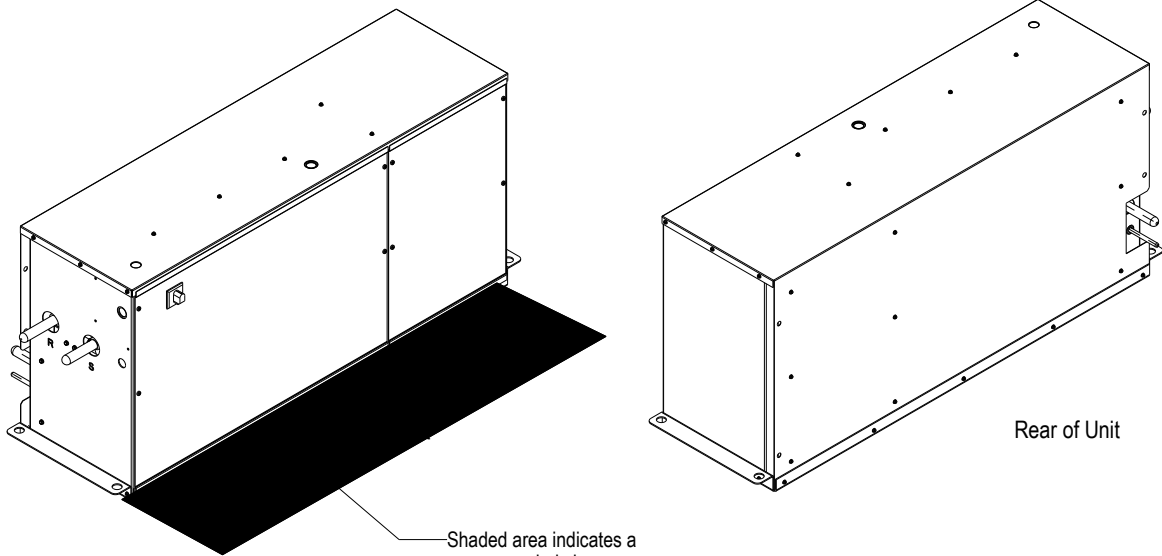

Shaded area indicates a recommended clearance 33" (838 mm) for component access and removal.

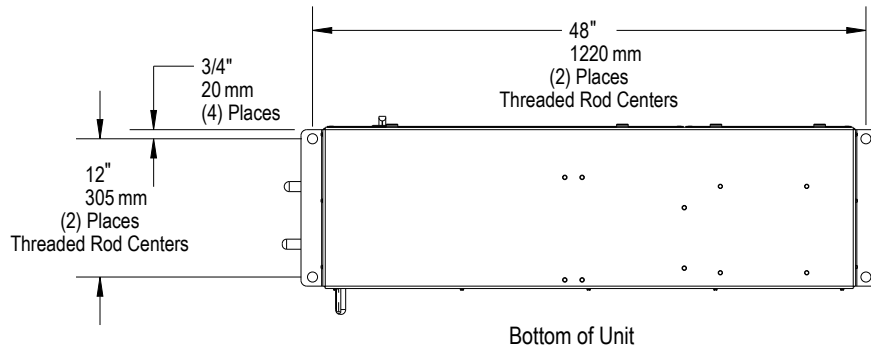
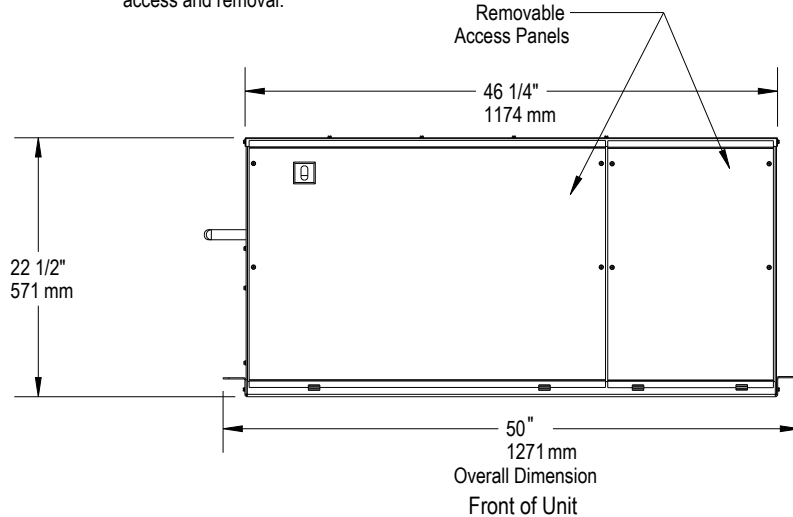
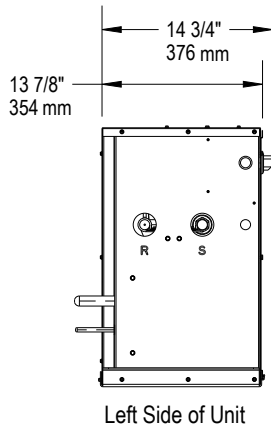

Model #	Unit Net Weight lbs. (kg)
MTC38W	237(107.5)
MTC55W	
MTC69W	

CABINET DIMENSIONAL DATA

3-4-5 TON AIR COOLED INDOOR CONDENSING UNIT

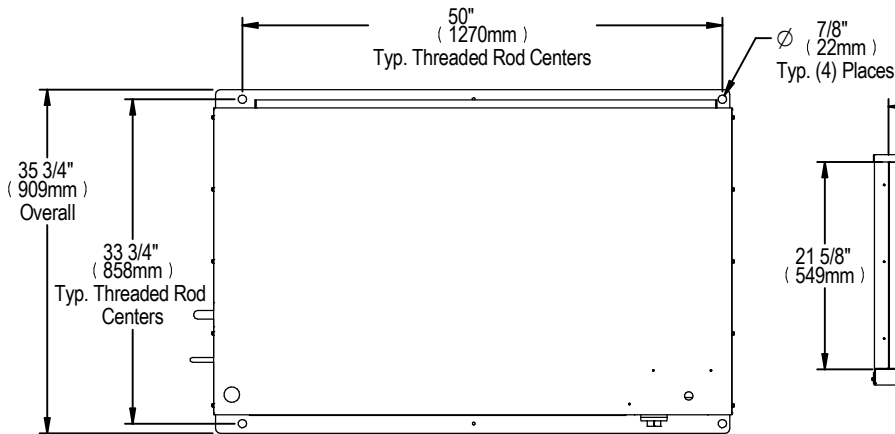
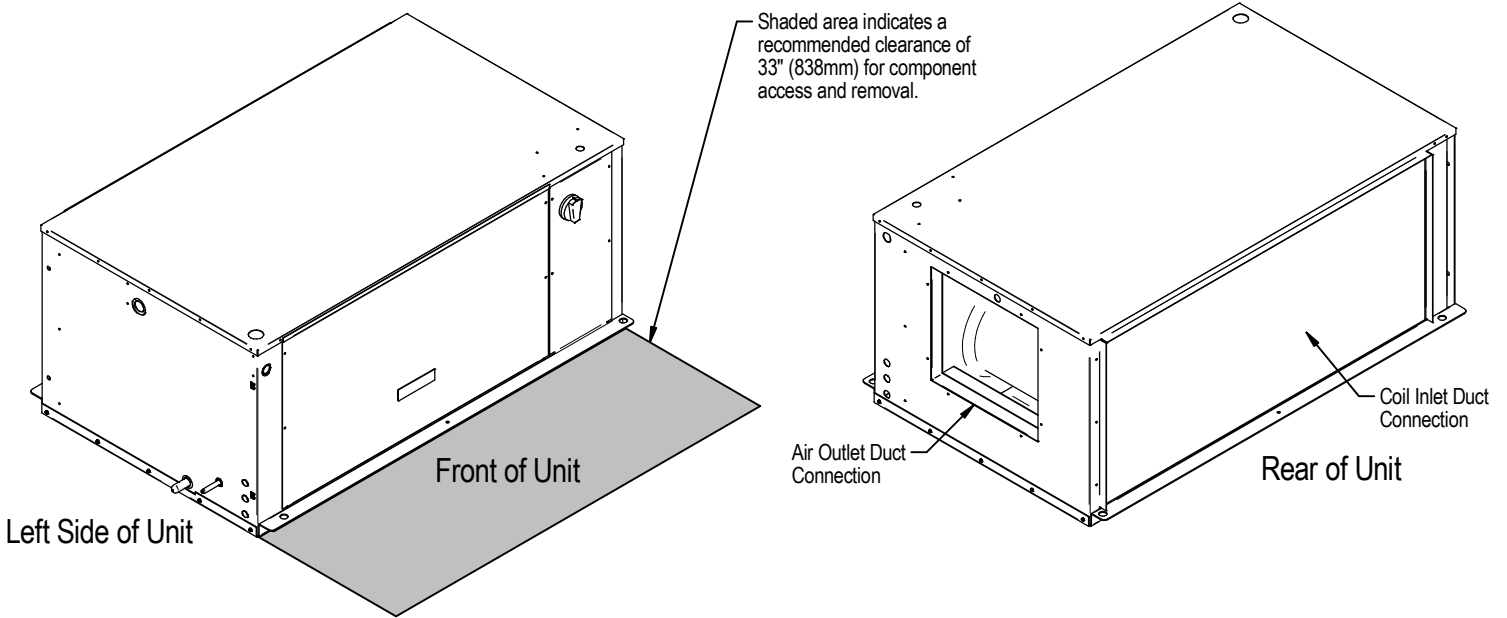

Top of Unit

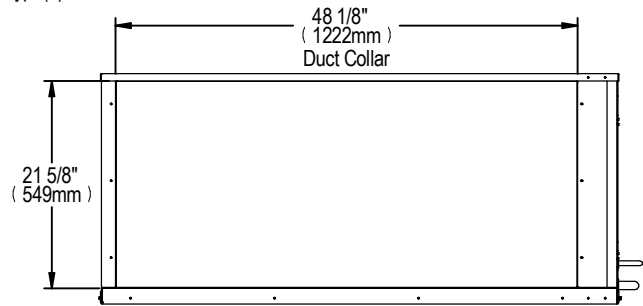

Rear of Unit

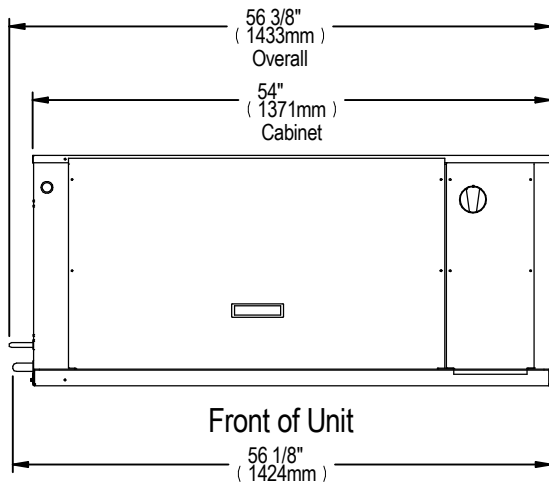

Front of Unit

CABINET DIMENSIONAL DATA
3-4-5 TON AIR COOLED INDOOR CONDENSING UNIT

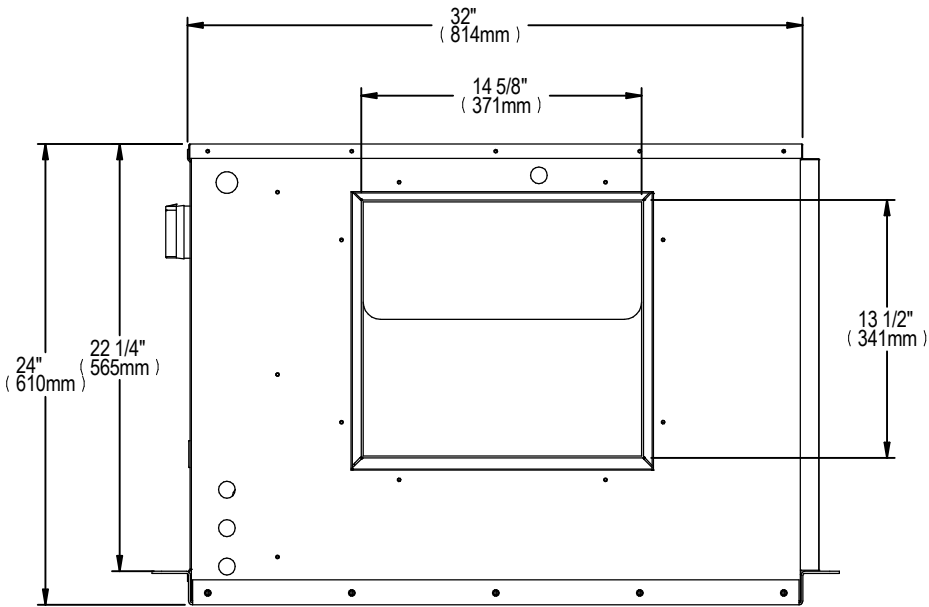

Model #	Net Wt. lbs. (kg)
MTC45A	408 (185)
MTC65A	

Right Side of Unit
 4-5 Ton Unit

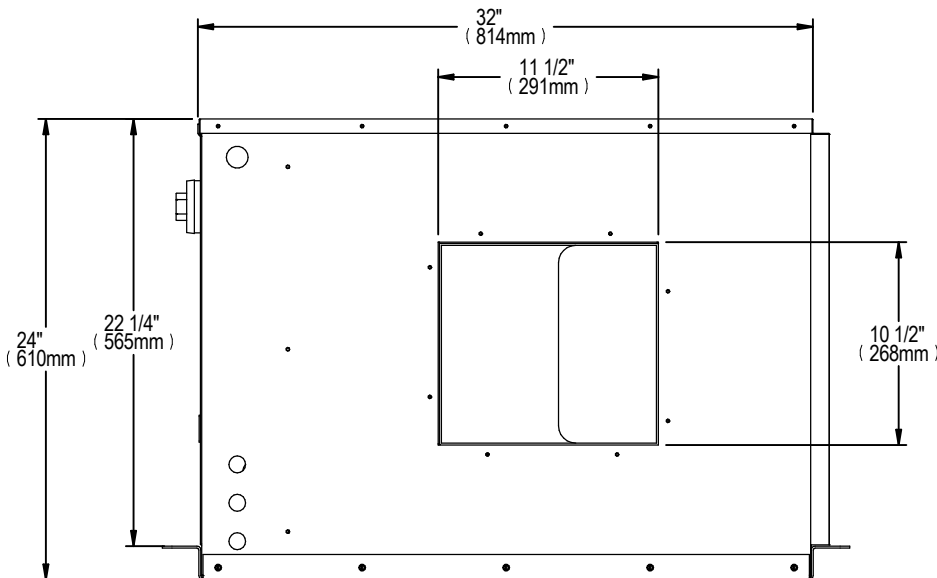

Model #	Net Wt. lbs. (kg)
MTC36A	350 (159)

Right Side of Unit
 3 Ton Unit



LIEBERT® MTC

GENERAL ARRANGEMENT DIAGRAM

3/4/5 TON WATER/GLYCOL COOLED INDOOR CONDENSING UNIT

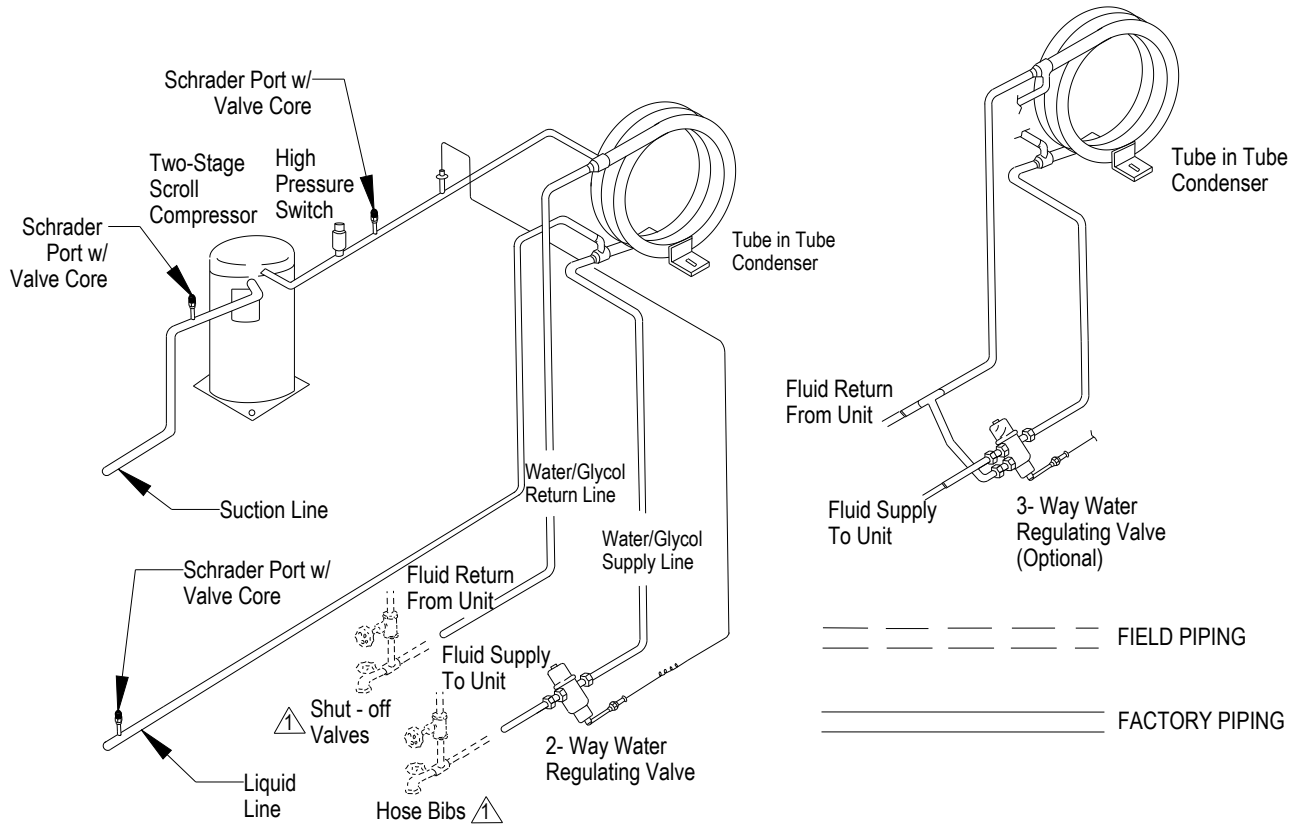

Notes:
 ⚠ Components are not supplied by Vertiv but are required for proper circuit operation and maintenance.



LIEBERT® MINI-MATE VARIABLE CAPACITY

GENERAL ARRANGEMENT 3-4-5 TON AIR COOLED CONDENSING UNIT

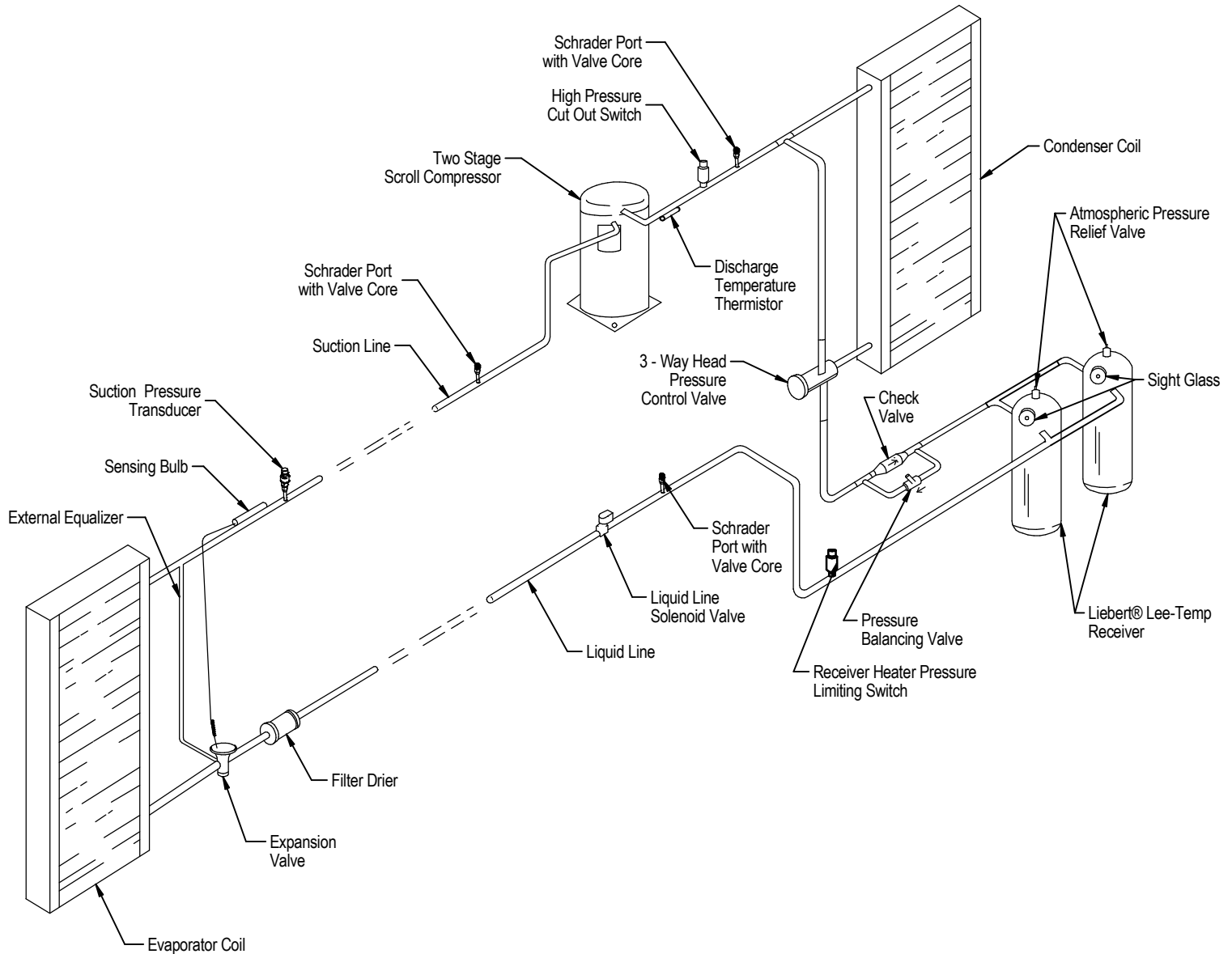

--- FIELD PIPING
==== FACTORY PIPING



LIEBERT® MTC

PRIMARY CONNECTION LOCATIONS 3/4/5 TON WATER/GLYCOL COOLED INDOOR CONDENSING UNIT

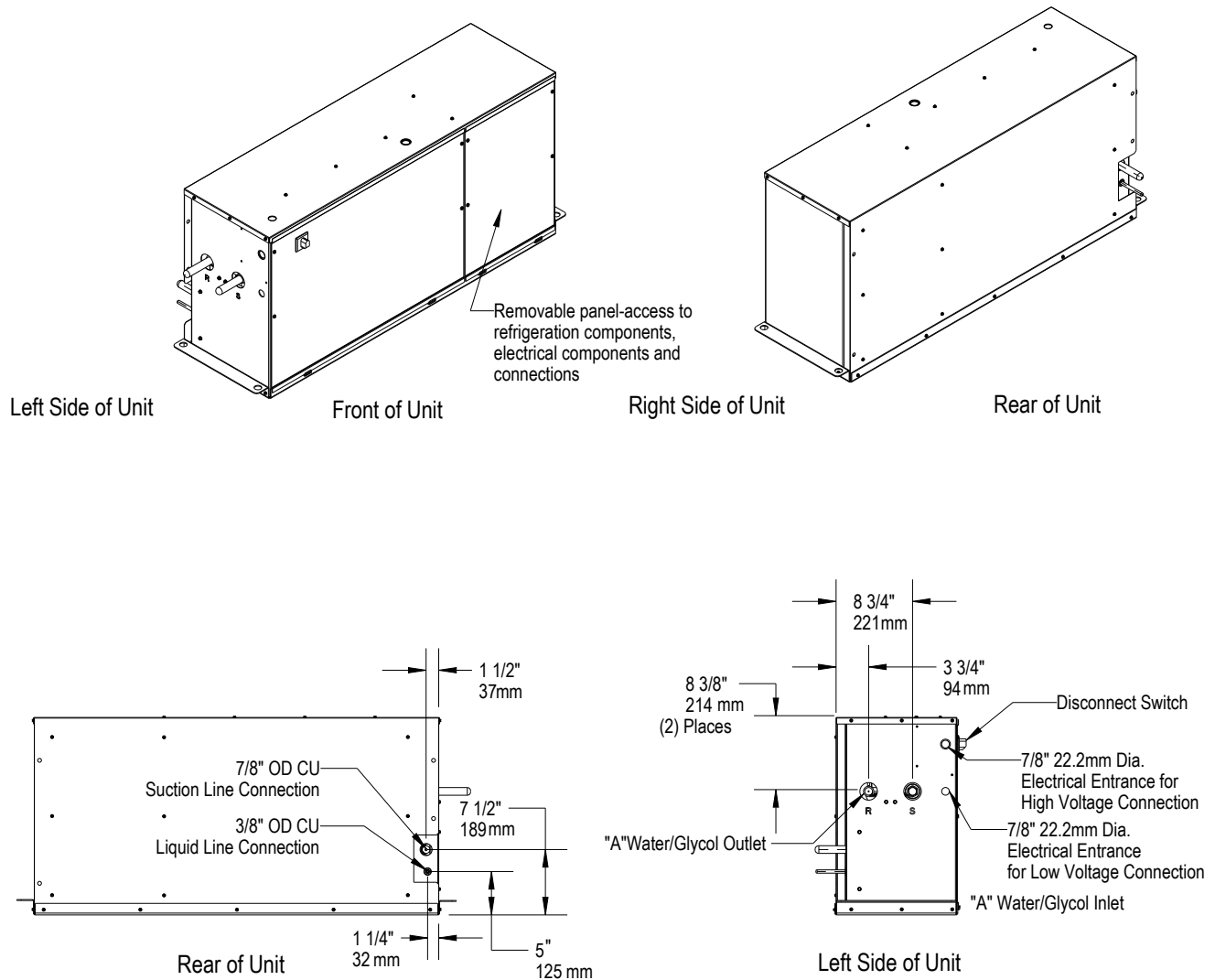

Model #	"A"
MTC38W	7/8" OD CU
MTC55W	1 1/8" OD CU
MTC69W	1 1/8" OD CU

PRIMARY CONNECTION LOCATIONS 3-4-5 TON AIR COOLED CONDENSING UNIT

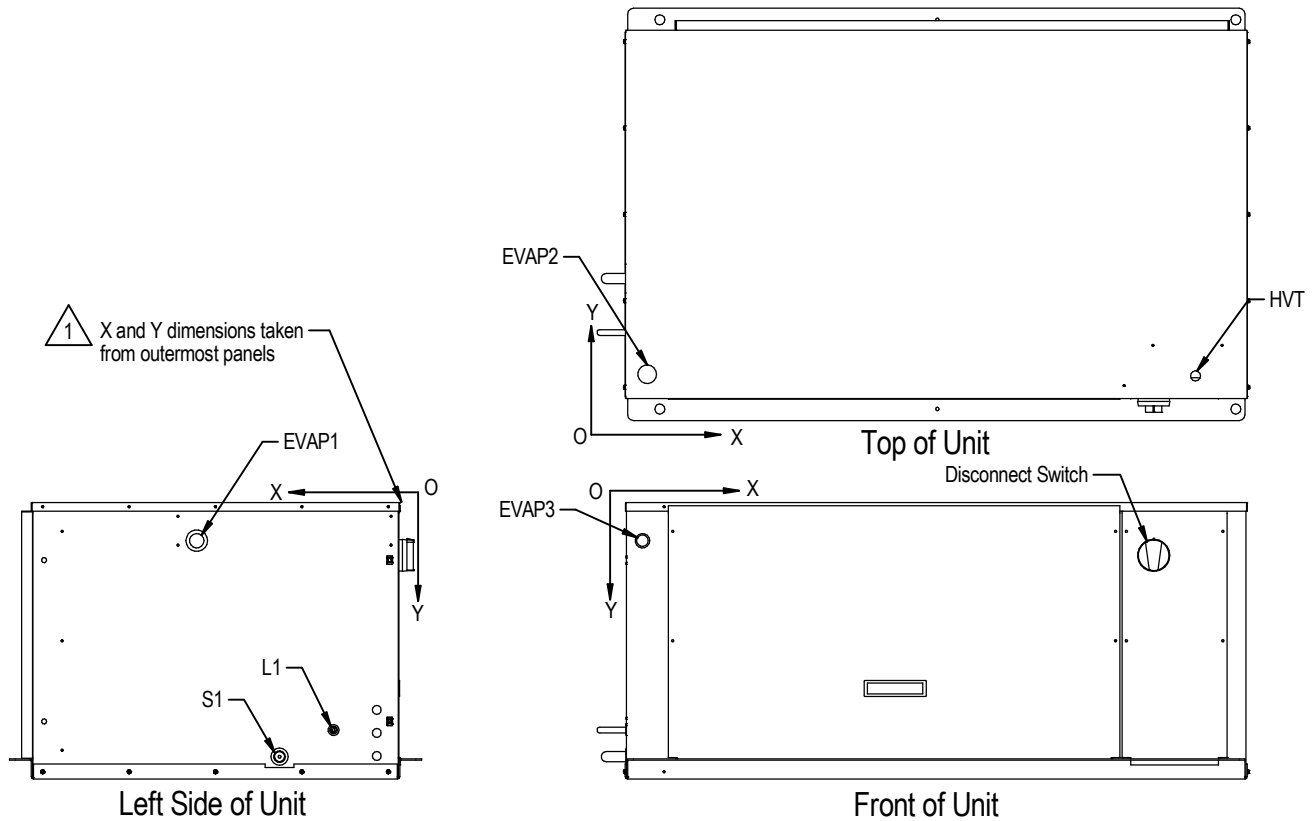
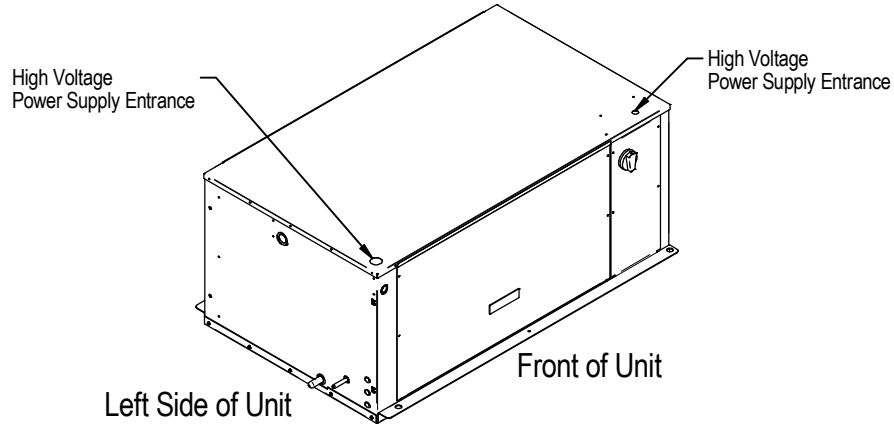

Connection	Description	X in. (mm)	Y in. (mm)	Size
EVAP1	Single Point Power Kit to Evaporator	17-11/16 (449)	3-5/16 (84)	1-1/4 (32)
EVAP2	High Voltage Top Connection Evaporator	1-7/8 (48)	2-1/8 (54)	1-5/8 (41)
EVAP3	High Voltage Connection (Single Point Power Kit)	1-1/2 (38)	3-5/16 (84)	1 (25)
HVT	High Voltage Top Connection	49-1/2 (1257)	2 (51)	7/8 (22)
S1	Suction Line	10-7/16 (265)	22-1/16 (560)	1" O.D. Cu
L1	Liquid Line	5-3/4 (146)	19-3/4 (502)	3/4" O.D. Cu

Note:

1. Drawing not to scale. All dimensions from rear corner of unit including panels, and have a tolerance on all piping dimensions is $\pm 1/2"$ (13mm).



LIEBERT® MTC

ELECTRICAL FIELD CONNECTIONS

3/4/5 TON WATER/GLYCOL COOLED INDOOR CONDENSING UNIT

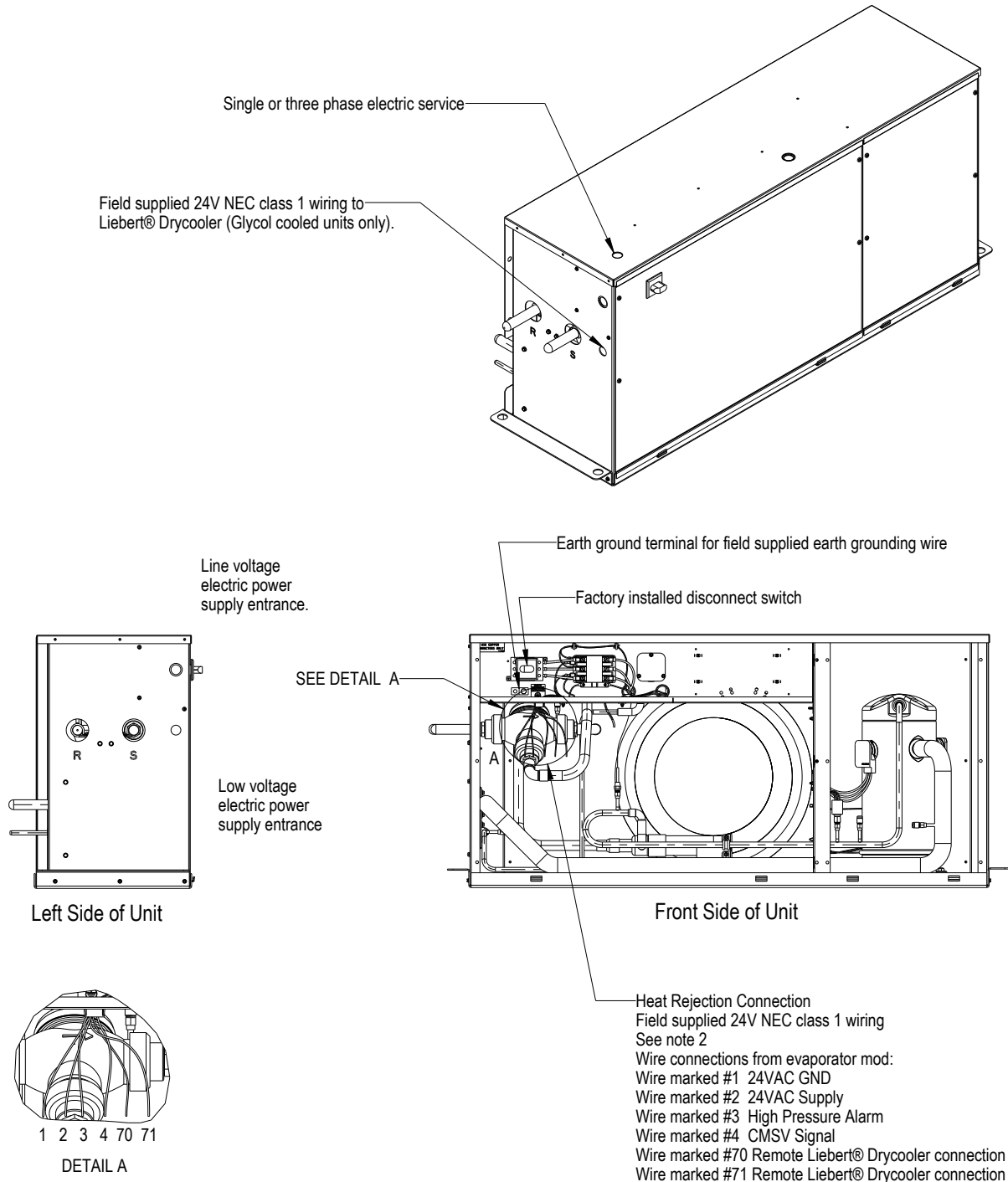

NOTES:

1. Refer to specification sheet for full load amp and wire size amp ratings.
2. Control voltage wiring must be a minimum of 16GA (1.3mm) for up to 75' (23m) or not to exceed 1 volt drop in control line.

ELECTRICAL FIELD CONNECTIONS 3-4-5 TON AIR COOLED CONDENSING UNIT

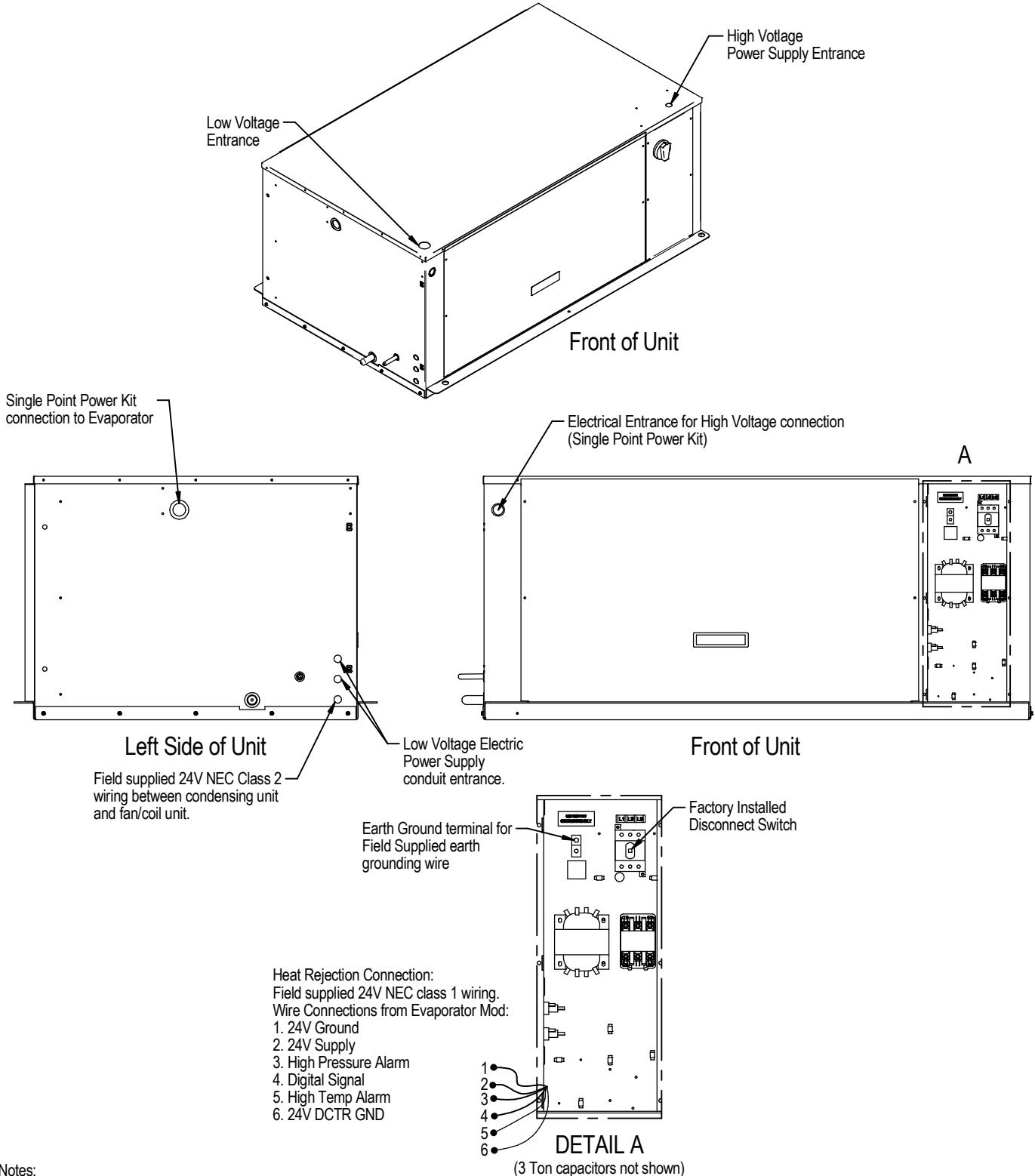

Notes:

1. Refer to specification sheet for full load amp and wire size amp ratings.
2. Control Voltage Wiring must be a minimum of 16ga. (1.3mm) for up to 75' (23m) or not to exceed 1 volt drop in control line.

This page intentionally left blank

Connect with Vertiv on Social Media



<https://www.facebook.com/vertiv/>



<https://www.instagram.com/vertiv/>



<https://www.linkedin.com/company/vertiv/>



<https://www.twitter.com/Vertiv/>



Vertiv.com | Vertiv Headquarters, 505 N Cleveland Ave, Westerville, OH 43082 USA

©2024 Vertiv Group Corp. All rights reserved. Vertiv™ and the Vertiv logo are trademarks or registered trademarks of Vertiv Group Corp. All other names and logos referred to are trade names, trademarks or registered trademarks of their respective owners. While every precaution has been taken to ensure accuracy and completeness here, Vertiv Group Corp. assumes no responsibility, and disclaims all liability, for damages resulting from use of this information or for any errors or omissions.

SL-10546_REV4_07-24