



Liebert[®] PFD

Installer/User Guide

**Prop Fan Digital Condensing Unit
Thermal Management Systems**

The information contained in this document is subject to change without notice and may not be suitable for all applications. While every precaution has been taken to ensure the accuracy and completeness of this document, Vertiv assumes no responsibility and disclaims all liability for damages resulting from use of this information or for any errors or omissions.

Refer to local regulations and building codes relating to the application, installation, and operation of this product. The consulting engineer, installer, and/or end user is responsible for compliance with all applicable laws and regulations relation to the application, installation, and operation of this product.

The products covered by this instruction manual are manufactured and/or sold by Vertiv. This document is the property of Vertiv and contains confidential and proprietary information owned by Vertiv. Any copying, use, or disclosure of it without the written permission of Vertiv is strictly prohibited.

Names of companies and products are trademarks or registered trademarks of the respective companies. Any questions regarding usage of trademark names should be directed to the original manufacturer.

Technical Support Site

If you encounter any installation or operational issues with your product, check the pertinent section of this manual to see if the issue can be resolved by following outlined procedures.

Visit <https://www.vertiv.com/en-us/support/> for additional assistance.

TABLE OF CONTENTS

1 Important Safety Instructions	1
2 Nomenclature and Components	5
2.1 Vertiv™ Liebert® PFD Model Number Nomenclature	5
2.2 Component Location	6
2.3 Optional Configurations	6
2.3.1 105°F (41°C) Ambient Models	6
2.3.2 Vertiv™ Liebert® Quiet-Line Models	6
2.3.3 Coated Coil	6
3 Pre-installation Preparation and Guidelines	7
3.1 Planning Dimensions	7
3.1.1 Location Considerations for Outdoor Condensing Unit	8
3.2 Connections and System Setup	8
3.3 Vertiv™ Liebert® PFD Unit Weights	8
3.4 Equipment Inspection and Handling	9
4 Piping and Refrigerant Requirements	11
4.1 Refrigerant Piping	11
4.1.1 Refrigerant Piping Guidelines for Air Cooled Systems	12
4.1.2 Piping when Condensing Unit is Above or Below Evaporator	13
4.2 Refrigerant-line Sizes and Equivalent Lengths	15
4.2.1 Refrigerant Charge Requirements	15
4.2.2 Additional Oil Requirements for Digital Scroll Compressors	17
5 Electrical Connection Requirements	23
5.1 Low Voltage, Control Connections	24
6 Checklist for Completed Installation	25
7 Initial Start-up Checks and Commissioning Procedure for Warranty Inspection	27
8 Maintenance	29
8.1 General Maintenance	30
8.2 Compressor Maintenance	31
8.2.1 Compressor Oil	31
8.2.2 Replacement Compressors	31
8.2.3 Compressor Electrical Failure (Motor Burnout)	31
8.2.4 Unloading Solenoid(s) on a Digital scroll Compressor	31
8.2.5 Replacing the Compressor	32
8.3 Condensing Unit Maintenance	33
9 Troubleshooting	35
Appendices	37
Appendix A: Technical Support and Contacts	37
Appendix B: Submittal Drawings	39

This page intentionally left blank

1 Important Safety Instructions

SAVE THESE INSTRUCTIONS

This manual contains important safety instructions that should be followed during the installation and maintenance of the Vertiv™ Liebert® PFD. Read this manual thoroughly before attempting to install or operate this unit.

Only qualified personnel should move, install or service this equipment.

Adhere to all warnings, cautions, notices and installation, operating and safety instructions on the unit and in this manual. Follow all installation, operation and maintenance instructions and all applicable national and local building, electrical and plumbing codes.



WARNING! Arc flash and electric shock hazard. Open all local and remote electric power supply disconnect switches, verify with a voltmeter that power is Off and wear appropriate, OSHA-approved personal protective equipment (PPE) per NFPA 70E before working within the electric control enclosure. Failure to comply can cause serious injury or death. Customer must provide earth ground to unit, per NEC, CEC and local codes, as applicable. Before proceeding with installation, read all instructions, verify that all the parts are included and check the nameplate to be sure the voltage matches available utility power. The Vertiv™ Liebert® iCOM™ controller does not isolate power from the unit, even in the "Unit Off" mode. Some internal components require and receive power even during the "Unit Off" mode of the controller. The only way to ensure that there is NO voltage inside the unit is to install and open a remote disconnect switch. Refer to unit electrical schematic. Follow all local codes.



WARNING! Risk of electric shock. Can cause equipment damage, injury or death. Open all local and remote electric power supply disconnect switches and verify with a voltmeter that power is off before working within any electric connection enclosures. Service and maintenance work must be performed only by properly trained and qualified personnel and in accordance with applicable regulations and manufacturers' specifications. Opening or removing the covers to any equipment may expose personnel to lethal voltages within the unit even when it is apparently not operating and the input wiring is disconnected from the electrical source.



WARNING! Risk of electric shock. Can cause serious injury or death. The Vertiv™ Liebert® iCOM™ microprocessor does not isolate power from the unit, even in the "Unit Off" mode. Some internal components require and receive power even during the "Unit Off" mode of the Liebert® iCOM™ control. Open all local and remote electric power disconnect switches and verify with a voltmeter that power is Off before working on any component of the system.



WARNING! Risk of over-pressurization of the refrigeration system. Can cause explosive discharge of high-pressure refrigerant, loss of refrigerant, environmental pollution, equipment damage, injury, or death. This unit contains fluids and gases under high pressure. Use extreme caution when charging the refrigerant system. Do not pressurize the system higher than the design pressure marked on the unit's nameplate. Relieve pressure before cutting into or making connections/disconnections to the piping system. Do not close off any field installed, refrigerant-line isolation valves for repairs unless a pressure-relief valve is field installed in the line between the isolation valve and the check valve. The pressure-relief valve must be rated 5% to 10% higher than the system-design pressure. An increase in ambient temperature can cause the pressure of the isolated refrigerant to rise and exceed the system-design pressure rating (marked on the unit nameplate).



WARNING! Risk of improper moving. Can cause equipment damage, injury or death. Use only lifting equipment that is rated for the unit weight by an OSHA-certified rating organization. The center of gravity varies depending on the unit size and selected options. The slings must be equally spaced on either side of the center of gravity indicator.

Unit weights are listed in **Table 3.2** on page 8 .



WARNING! Risk of contact with high speed rotating fan blades. Can cause serious injury or death. Open all local and remote electric power supply disconnect switches, verify with a voltmeter that power is off, and verify that all fan blades have stopped rotating before working in the unit cabinet or on the fan assembly. If control voltage is applied, the fan motor can restart without warning after a power failure. Do not operate the unit with any or all cabinet panels removed.



WARNING! Risk of improper wiring, piping, moving, lifting and handling. Can cause equipment damage, serious injury or death. Installation and service of this equipment should be done only by qualified personnel who have been specially-trained in the installation of air-conditioning equipment and who are wearing appropriate, OSHA-approved PPE.



WARNING! Risk of improper wire sizing/rating and loose electrical connections. Can cause overheated wire and electrical connection terminals resulting in smoke, fire, equipment and building damage, injury or death. Use correctly sized copper wire only and verify that all electrical connections are tight before turning power On. Check all electrical connections periodically and tighten as necessary.



CAUTION: Risk of contact with sharp edges, splinters, and exposed fasteners. Can cause injury. Only properly trained and qualified personnel wearing appropriate, OSHA-approved PPE should attempt to move, lift, remove packaging from or prepare the unit for installation.



CAUTION: Risk of contact with hot surfaces. Can cause injury. The compressor, refrigerant discharge lines, fan motor, and some electrical components are extremely hot during unit operation. Allow sufficient time for them to cool to a touch-safe temperature before working within the unit cabinet. Use extreme caution and wear appropriate, OSHA-approved PPE when working on or near hot components.



CAUTION: Risk of exposure to harmful noise levels. Can cause hearing injury or loss. Depending on the installation and operating conditions, a sound pressure level greater than 70 dB(A) may arise. Take appropriate technical safety measures. Operating personnel must wear appropriate, OSHA-approved PPE and observe all appropriate hearing-protection safety requirements.

NOTICE

Risk of improper power supply connection. Can cause equipment damage and loss of warranty coverage.

Prior to connecting any equipment to a main or alternate power source (for example: back-up generator systems) for startup, commissioning, testing, or normal operation, ensure that these sources are correctly adjusted to the nameplate voltage and frequency of all equipment to be connected. In general, power-source voltages should be stabilized and regulated to within $\pm 10\%$ of the load nameplate nominal voltage. Also, ensure that no three-phase sources are single-phased at any time.

NOTICE

Risk of oil contamination with water. Can cause equipment damage.

Vertiv™ Liebert® PFD systems require the use of POE (polyolester) oil. POE oil absorbs water at a much faster rate when exposed to air than previously used oils. Because water is the enemy of a reliable refrigeration system, extreme care must be used when opening systems during installation or service. If water is absorbed into the POE oil, it will not be easily removed and will not be removed through the normal evacuation process. If the oil is too wet, it may require an oil change. POE oils also have a property that makes them act as a solvent in a refrigeration system. Maintaining system cleanliness is extremely important because the oil will tend to bring any foreign matter back to the compressor.

NOTICE

Risk of improper refrigerant charging. Can cause equipment damage.

Refrigerant charge must be weighed into air cooled compressorized systems before they are started. Starting digital scroll compressors without proper refrigerant charging can cause the compressors to operate at less than 5°F (-15°C) evaporator temperature and at less than 55 psig (379 kPa). Operation for extended periods at less than 55 psig (379 kPa) can cause premature compressor failure.

NOTICE

Risk of damage from forklift. Can cause unit damage. Keep tines of the forklift level and at a height suitable to fit below the skid and/or unit to prevent exterior and/or underside damage.

NOTICE

Risk of improper storage. Can cause unit damage.

Keep the unit upright, indoors and protected from dampness, freezing temperatures and contact damage.

NOTICE

Condenser fans should be operated manually if they have not run for an extended time in an outdoor environment. Before enabling the condenser for normal cooling operation fans should be run at full speed for at least 3 hours once a month to move the bearings and allow any condensate that may have ingressed to evaporate.

Condenser firmware release 1.06.045 & later include settings to operate condenser fans if they have been inactive for more than 30 days.

Agency Listed

Standard 60-Hz units are CSA Certified to the harmonized U.S. and Canadian product safety standard CSA C22.2 No 236/UL 1995 for “Heating and Cooling Equipment” and are marked with the CSA c-us logo.



2 Nomenclature and Components

This section describes the model number for Vertiv™ Liebert® PFD units and components.

2.1 Vertiv™ Liebert® PFD Model Number Nomenclature

Table 2.2 below describes each digit of the model number.

Table 2.1 Prop-fan Condensing Unit Model Number Example

1	2	3	4	5	6	7	8	9	10	11
P	F	D	0	6	7	A	—	A	L	1

Table 2.2 Model Number Digit Definitions for Outdoor, Prop-fan Condensing Units

Digit and Description
Digits 1, 2 = The base unit PF = Prop-fan condensing unit
Digit 3 = Compressor type D = Digital scroll compressor
Digit 4 = Sound level O = Standard Z = Quiet-Line (067 models only)
Digits 5 and 6 = Nominal Capacity, 1,000 BTU/hr
Digit 7 = Unit type A = Air cooled
Digit 8 = Coil type — = Standard coil C = Coated coil (epoxy with UV topcoat)
Digit 9 = Supply power A = 460 V / 3 ph / 60 Hz B = 575 V / 3 ph / 60 Hz (054 and 067 models only) P = 208-230 V / 1 ph / 60 Hz (037 model only) Y = 208-230 V / 3 ph / 60 Hz
Digit 10 = Head pressure control L = 95°F Ambient, Liebert® Lee-Temp H = 105°F Ambient, Liebert Lee-Temp (not available on 048 model)
Digit 11 = Refrigerant 1 = R-410A, field supplied

2.2 Component Location

The unit component locations are described in the submittal documents included in the [Submittal Drawings](#) on page 39 .

The following tables list the relevant documents by number and title.

Table 2.3 Component Location Drawings

Document Number	Title
DPN004180	PFD Condensing Unit, 3-, 4-, and 5-ton

2.3 Optional Configurations

2.3.1 105°F (41°C) Ambient Models

These models are similar to the base models with coils and fans sized to provide catalog capacity of the appropriate evaporator section up to 105°F (41°C) outside ambient temperature.

2.3.2 Vertiv™ Liebert® Quiet-Line Models

These models are similar to the base models with coils and fans sized to provide catalog capacity of the appropriate evaporator section up to 95°F (35°C) outside ambient temperature with a noise level of less than 58 dBA.

2.3.3 Coated Coil

This option provides epoxy-coated coil(s) with UV topcoat for extended coil life in corrosive environments, such as coastal areas. Can be added to any ambient/sound configuration.

3 Pre-installation Preparation and Guidelines

NOTE: Before installing unit, determine whether any building alterations are required to run piping, wiring and duct work. Follow all unit dimensional drawings and refer to the submittal engineering dimensional drawings of individual units for proper clearances.

Refer to [Vertiv™ Liebert® PFD Model Number Nomenclature](#) on page 5 , and submittal drawings to determine the type of system being installed and anticipate building alterations, piping and duct work needed.

The unit dimensions, pipe-connection locations, and piping schematics are described in the submittal documents included in the [Submittal Drawings](#) on page 39 .

- Allow at least the minimum recommended clearances maintenance, and service. See the appropriate submittal drawings for dimensions.
- Be mindful of the placement of the Liebert® PFD in relation to the connected evaporator unit, other outside units, barriers, and walls for air flow clearance, equivalent piping distances, and differences in elevation between the Liebert® PFD and connected evaporator unit.
- When applications do not meet or exceed any of these specifications, contact your Vertiv™ representative.

3.1 Planning Dimensions

The unit dimensions described in the submittal documents included in the [Submittal Drawings](#) on page 39 .

The following table lists the relevant submittal documents by number and title.

Table 3.1 Dimension Planning Drawings

Document Number	Title
Outdoor Condensing Unit	
DPN004058	Cabinet dimensions, 5-ton, top discharge
DPN004063	Cabinet dimensions, 3-, 4-, and 5-ton, horizontal discharge
DPN004066	Optional anchoring plan, 3-, 4-, and 5-ton, horizontal discharge

3.1.1 Location Considerations for Outdoor Condensing Unit

Observe the following when planning the installation of the outdoor unit:

- To ensure a satisfactory air supply, locate air cooled condensing units in an environment with clear air, away from loose dirt and foreign matter that may clog the coil.
- Condensing units must not be located in the vicinity of steam, hot air or fume exhausts or closer than 18 in. (457 mm) from a wall, obstruction or adjacent unit.
- For multiple-unit installations, space the units so that the hot, condensing-unit exhaust air is not directed toward the air inlet of an adjacent unit.
- Avoid areas where heavy snow will accumulate at air inlet and discharge locations.
- The condensing unit should be located for maximum security and maintenance accessibility. Avoid ground-level sites with public access. Install a solid base, capable of supporting the weight of the condensing unit.
- The base should be at least 2 in. (51 mm) higher than the surrounding grade and 2 in. (51 mm) larger than the dimensions of the condensing-unit base. For snowy areas, a base of sufficient height to clear snow accumulation must be installed.

Before beginning, refer to [Piping and Refrigerant Requirements](#) on page 11, and [Piping when Condensing Unit is Above or Below Evaporator](#) on page 13, for unit placement, piping guidelines, and refrigerant-charge requirements for your system.

3.2 Connections and System Setup

- Electrical service is required for all models. Electrical service must conform to national and local electrical codes. See equipment nameplate for details.
- Plan the routing of wiring, piping and duct work to the unit. Refer to the appropriate piping connection location drawings, piping schematics, and electrical connection drawings for your system in.

3.3 Vertiv™ Liebert® PFD Unit Weights

Table 3.2 Liebert® PFD Unit Weights

Model #	Weight, lb (kg)
PFD037A-L	244 (111)
PFD037A-H	351 (159)
PFD054A-L	351 (159)
PFD067A-L	351 (159)
PFD067A-H	488 (222)
PFDZ67A-L	488 (222)

3.4 Equipment Inspection and Handling

SAFETY INFORMATION



WARNING! Risk of improper moving, lifting, or handling of the unit. Can cause equipment damage, injury or death. Read all of the following instructions and verify that all lifting and moving equipment is rated for the weight of the unit before attempting to move, lift, remove packaging from or prepare the unit for installation. Unit weights are specified in **Table 3.2** on the previous page .



CAUTION: Risk of contact with sharp edges, splinters, and exposed fasteners. Can cause injury. Only properly trained and qualified personnel wearing appropriate, OSHA-approved PPE should attempt to move, lift, remove packaging from or prepare the unit for installation.

NOTICE

Risk of damage from forklift. Can cause unit damage. Keep tines of the forklift level and at a height suitable to fit below the skid and/or unit to prevent exterior and/or underside damage.

When the unit arrives, inspect all items for any visible or concealed damage. Report any damage to the carrier immediately and file a damage claim. Send a copy of the claim to your Vertiv™ representative.

If possible, maintain equipment and packaging until it is at the installation location.

This page intentionally left blank

4 Piping and Refrigerant Requirements

All refrigeration connections to the unit are sweat copper. Factory installed piping brackets must not be removed. Field installed piping must be installed in accordance with local codes and must be properly assembled, supported, isolated and insulated. Avoid piping runs through noise-sensitive areas, such as office walls and conference rooms.

Refer to specific text and detailed diagrams in this manual for other unit specific piping requirements.

The pipe connection locations, piping general arrangement and schematics are described in the submittal documents included in the [Submittal Drawings](#) on page 39 .

The following tables list the relevant documents by number and title.

Table 4.1 Piping General-arrangement Drawings

Document Number	Title
DPN004060	Piping arrangement, 3-, 4- and 5-ton split-system.
DPN004062	Piping arrangement, Condensing unit.

Table 4.2 Piping Connection Drawings

Document Number	Title
DPN004059	Primary connection locations, top discharge.
DPN004064	Primary connection locations, horizontal discharge.

4.1 Refrigerant Piping



WARNING! Risk of over-pressurization of the refrigeration system. Can cause explosive discharge of high-pressure refrigerant, loss of refrigerant, environmental pollution, equipment damage, injury, or death. This unit contains fluids and gases under high pressure. Use extreme caution when charging the refrigerant system. Do not pressurize the system higher than the design pressure marked on the unit's nameplate. Relieve pressure before cutting into or making connections/disconnections to the piping system. Do not close off any field installed, refrigerant-line isolation valves for repairs unless a pressure-relief valve is field installed in the line between the isolation valve and the check valve. The pressure-relief valve must be rated 5% to 10% higher than the system-design pressure. An increase in ambient temperature can cause the pressure of the isolated refrigerant to rise and exceed the system-design pressure rating (marked on the unit nameplate).

Consult local building and plumbing codes for installation requirements of additional pressure-relief devices when isolation valves are field installed. Do not isolate any refrigerant circuits from over-pressurization protection. The Vertiv™ Liebert® PFD condensing unit includes a factory installed pressure-relief valve mounted on top of the receiver. The valve is rated for a maximum working pressure of 675 psig.

Table 4.3 System Refrigerant Pressures

Refrigerant 4-410A		
	High Side	Low Side
Design Pressure	530 psig	235 psig
	3,655 kPa	1620 kPa
High Pressure Cutout	590 psig	N/A
	3999 kPa	
Field installed interconnecting piping must be properly selected and installed based on local and national codes, the user manual, and the unit serial tag. Source: DPN000788, REV 15.		

NOTICE

Risk of oil contamination with water. Can cause equipment damage.

Vertiv™ Liebert® PFD systems require the use of POE (polyolester) oil. POE oil absorbs water at a much faster rate when exposed to air than previously used oils. Because water is the enemy of a reliable refrigeration system, extreme care must be used when opening systems during installation or service. If water is absorbed into the POE oil, it will not be easily removed and will not be removed through the normal evacuation process. If the oil is too wet, it may require an oil change. POE oils also have a property that makes them act as a solvent in a refrigeration system. Maintaining system cleanliness is extremely important because the oil will tend to bring any foreign matter back to the compressor.

NOTICE

Risk of improper refrigerant charging. Can cause equipment damage.

Refrigerant charge must be weighed into air cooled compressorized systems before they are started. Starting digital scroll compressors without proper refrigerant charging can cause the compressors to operate at less than 5°F (-15°C) evaporator temperature and at less than 55 psig (379 kPa). Operation for extended periods at less than 55 psig (379 kPa) can cause premature compressor failure.

NOTICE

Units should never be operated with no refrigerant charge, a holding charge, a proper load or without additional oil as required added. Tag out system to prevent unauthorized personnel from accidentally starting equipment and damaging compressors if any of these conditions exist.

4.1.1 Refrigerant Piping Guidelines for Air Cooled Systems

- Evaporators and condensing units ship with an inert-gas holding charge. Do not vent the evaporator and condensing unit until all refrigerant piping is in place, ready for connection to the unit and condensing unit.
- Use copper piping with a brazing alloy with a minimum temperature of 1350°F (732°C), such as Sil-Fos. Avoid soft solders, such as 50/50 or 95/5.
- Use a flow of dry nitrogen through the piping during brazing to prevent formation of copper oxide scale inside the piping. When copper is heated in the presence of air, copper oxide forms. POE oils will dissolve these oxides from inside the copper pipes and deposit them throughout the system, clogging filter driers and affecting other system components.
- A pure dry nitrogen flow of 1-3 ft³/min (0.5-1.5 l/s) inside the pipe during brazing is sufficient to displace the air. Control the flow using a suitable measuring device.
- Ensure that the tubing surfaces to be brazed are clean and that all burrs have been removed from the ends of the tubes.

- Ensure that all loose material has been cleaned from inside the tubing before brazing.
- Protect all refrigerant line components within 18 in. (460 mm) of the brazing site by wrapping them with a wet cloth or with a suitable heat-sink compound.
- Isolate piping from building using vibration-isolating supports.
- When sealing openings in walls and to reduce vibration transmission, use a soft, flexible material to pack around the tubes to prevent tube damage.
- When installing remote condensing units above the evaporator, the suction gas lines should be trapped at the evaporator. These traps will retain refrigerant oil in the off cycle. When the unit starts, oil in the traps is carried up the vertical risers and returns to the compressors. For rises over 25 ft (7.6 m), trap every 20 ft (6 m) or evenly-divided.
- Consult factory if piping run exceeds 150 ft (46 m) equivalent length.
- Keep piping clean and dry, especially on units with R-410A refrigerant.
- Avoid piping runs through noise-sensitive areas.
- Do not run piping directly in front of discharge air stream.
- Refrigerant oil – do not mix oil types.

Refer to ASHRAE Refrigeration Handbook for general, good-practice refrigeration piping.

NOTE: All indoor and outdoor suction-line piping must have 1/2 in. minimum of insulation. All outdoor insulation must be UV and ozone resistant.

NOTE: Proper safety equipment and proper refrigeration tools are required when working with R-410A refrigerant. Check unit serial tag for correct refrigerant type before topping-off or recharging a system.

NOTE: Refrigerant R-410A uses a POE (polyolester) lubricant. The refrigerant must be introduced and charged from the cylinder only as a liquid.

NOTE: When installing field piping, you must take care to protect all refrigerant lines from the atmosphere especially when using refrigerants with POE oils. Do not allow the piping to stand open to air for more than 15 minutes. Units designed for R-410A have a compressor that contains POE oil, which quickly absorbs water from the air. The longer that the refrigerant piping is left open to air, the harder it will be to fully evacuate the system. If left open too long, the POE oil may require replacement to achieve the required vacuum level.

- Refer to [Refrigerant-line Sizes and Equivalent Lengths](#) on page 15 , for recommended refrigerant piping sizes based on equivalent pipe lengths.
- Refer to [Refrigerant Charge Requirements](#) on page 15 , for the refrigerant-charge requirements of the system.

4.1.2 Piping when Condensing Unit is Above or Below Evaporator

Refer to **Table 4.4** on the next page , for the maximum vertical rise/fall between condensing unit and evaporator.

When installing remote condensing units above the evaporator, trap the suction gas line at the evaporator as shown in **Figure 4.1** on the next page . Traps recommended at the base of riser exceeding 5 ft (1.5 m) and every 20 ft (6 m) of vertical rise. This trap will retain refrigerant oil during the "Off" cycle. When the unit starts, oil in the trap is carried up the vertical riser and returns to the compressor.

When installing remote condensing units below the evaporator, trap the suction gas line with an inverted trap the height of the evaporator as shown in the following figure. This prevents refrigerant migration to the compressor during "Off" cycles.

Table 4.4 Pipe Length and Condensing Unit Elevation Relative to Evaporator

Maximum Equivalent Pipe Length, ft (m)	Maximum Condensing-unit Level Above Evaporator, ft (m)	Maximum Condensing-unit Level Below Evaporator, ft (m)
150 (45)	50 (15)	15 (4.6)

Figure 4.1 Refrigerant Piping When Condensing Unit is Above or Below Evaporator

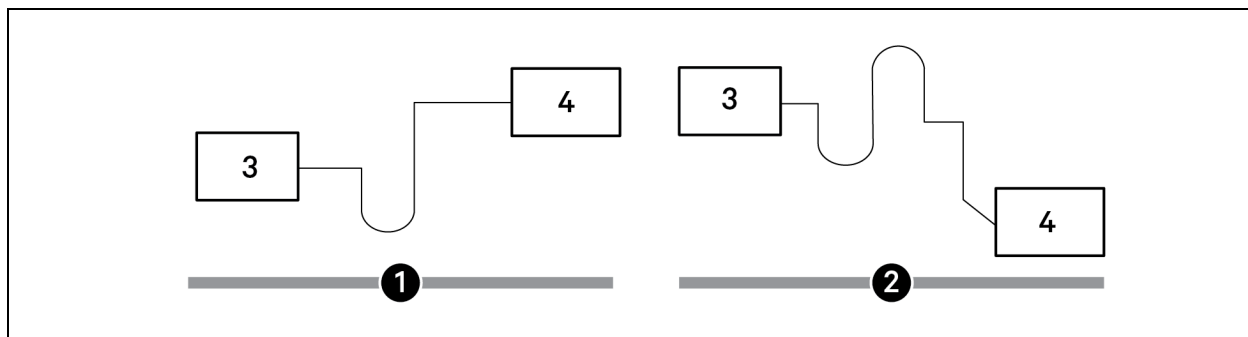

NOTE: Any horizontal pipe must be pitched down toward the condensing unit at a minimum rate of 1/2 in. (13 mm) per 10 ft (3 m) to assure oil return to compressor.

Item	Description
1	Condensing unit above evaporator
2	Condensing unit below evaporator
3	Evaporator
4	Condensing unit

4.2 Refrigerant-line Sizes and Equivalent Lengths

The following tables list the information required to field install the refrigerant piping for the system.

Table 4.5 Recommended Refrigerant Line Sizes, OD cu by Equivalent Length

System Models		Equivalent Length, ft (m)				
		50 (15)	75 (23)	100 (30)	125 (38)	150 (45)
MT036E/PFD037A-*L or PFD037A-*H	Suction line, in.	7/8	7/8	7/8	7/8	7/8
	Liquid line, in.	1/2	1/2	1/2	1/2	1/2
MT048HE/PFD054A-*L	Suction line, in.	7/8	1-1/8 ¹	1-1/8 ¹	1-1/8 ¹	1-1/8 ¹
	Liquid line, in.	1/2	1/2	5/8	5/8	5/8
MT060HE/PFD067A-*L	Suction line, in.	1-1/8	1-1/8	1-1/8	1-1/8	1-1/8
	Liquid line, in.	1/2	5/8	5/8	5/8	5/8
MT060HE/PFDZ67A-*L or PFD067A-*H	Suction line, in.	1-1/8	1-1/8	1-1/8	1-1/8	1-1/8
	Liquid line, in.	1/2	5/8	5/8	5/8	5/8

Consult factory for proper line sizing for runs longer than maximum equivalent length shown.

¹ Use one line size smaller on suction lines for vertical risers.

4.2.1 Refrigerant Charge Requirements

To calculate the charge requirements:

1. Determine the charge for your units by model number from the following tables.
2. Determine the charge for the piping by line size and length.
3. Add these all together to obtain the total refrigerant charge for your system.

Table 4.6 Indoor Evaporator Approximate R-410A Refrigerant Charge

Model #	Charge, lb (kg)
MT036HE	1 (0.45)
MT048HE	2.2 (1.0)
MT060HE	2.2 (1.0)

Table 4.7 Interconnecting Piping Refrigerant Charge for R-410A Using Type L Copper Tube

Line Size, OD, in.	Liquid Line, lb/100 ft (kg/30 m)	Suction Line, lb/100 ft (kg/30 m)
3/8	3.2 (1.4)	—
1/2	5.9 (2.7)	0.2 (0.1)
5/8	9.6 (4.3)	0.4 (0.2)
3/4	14.3 (6.4)	0.6 (0.3)
7/8	19.8 (8.8)	0.8 (0.4)
1-1/8	33.8 (15.1)	1.4 (0.6)
1-3/8	51.5 (23.0)	2.1 (1.0)

Source: DPN003099 Rev. 1

Table 4.8 Vertiv™ Liebert® PFD R-410A Refrigerant Charge

Model #	Charge, lb (kg)
PFD037A-*L1	13.4 (6.1)
PFD037A-*H1	27 (12.2)
PFD054A-*L1	27 (12.2)
PFD067A-*L1	27 (12.2)
PFDZ67A-*L1	57 (25.8)
PFD067A-*H1	57 (25.8)

4.2.2 Additional Oil Requirements for Digital Scroll Compressors

NOTICE

Risk of improper compressor lubrication. Can cause compressor and refrigerant system damage.

Failure to use oil types, viscosities and quantities recommended by the compressor manufacturer may reduce compressor life and void the compressor warranty. See **Table 8.1** on page 31 for the recommended oil for the system.

- Do not mix polyolester (POE) and mineral-based oils.
- Do not mix oils of different viscosities.
- Consult your Vertiv sales representative, visit <https://www.Vertiv.com/en-us/support/>, or contact the compressor manufacturer if questions arise.

See **Table 4.9** on the next page, for the amount required for various system charge levels.

In addition to oil added based on system charge, additional oil is required for discharge-line field installed traps. Standard formed tube traps are required, see **Figure 4.2** below, and **Table 4.10** on the next page, because straight tubes and fittings used as traps require much more oil and the length of the straight tube can vary.

With the total calculated refrigerant charge for each circuit, see **Table 4.9** on the next page for the refrigerant charge amount that was calculated and follow that line to the right to see how much additional compressor oil is required for each circuit. Count the numbers of traps in each circuit. See **Table 4.10** on the next page for the discharge line pipe diameter. Follow the line to the right to see how much oil is needed per trap. Multiply the number of traps per circuit by the Oil volume. Add the additional compressor oil amount and the trap oil volume together. This will be the total amount of oil that will need to be added before the refrigerant is added to each circuit.

Figure 4.2 Standard Formed Tube Trap Versus Straight Tubes and Fittings Trap

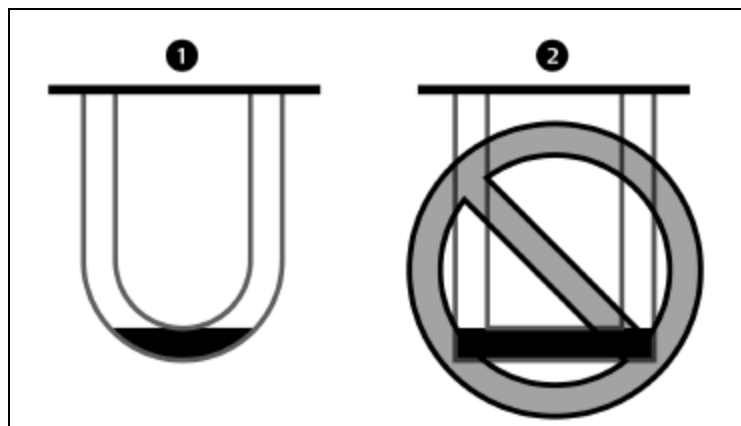

Item	Description
1	Standard formed tube trap
2	Straight tubes and fittings trap

Table 4.9 Additional Oil Required per Refrigerant Charge

Refrigerant System Charge per Circuit, lb (kg) *	Model		
	PFD037	PFD054	PFD067, PFDZ67
	Additional Oil Required Per Circuit, oz (ml)		
< 40 (18.1)	0	0	0
40 (18.1)	4 (120)	4 (120)	6 (180)
50 (22.7)	6 (180)	6 (180)	9 (270)
60 (27.2)	8 (240)	8 (240)	12 (350)
70 (31.8)	10 (300)	10 (300)	15 (440)
80 (36.3)	12 (350)	12 (350)	18 (530)

* System Charge = indoor unit + condensing unit + refrigerant lines.
For system charges over 80lb. (36.3 kg), consult your Vertiv™ representative.

Source: DPN003950 Rev. 6

Table 4.10 Volume of Oil in Standard Form Trap by Pipe Diameter

Pipe diameter, in.	Oil volume, oz (ml)
1/2	0.2 (5.9)
5/8	0.4 (11.8)
3/4	0.6 (17.7)
7/8	0.9 (26.6)
1-1/8	1.8 (53.2)
1-3/8	3.3 (97.6)
1-5/8	5.5 (162.7)

Source: DPN003950, Rev. 6

Evacuation and Leak Testing Air Cooled Systems

For proper leak-check and evacuation, you must open all system valves and account for all check valves, see **Figure 4.3** below .

Figure 4.3 Valves and Connections

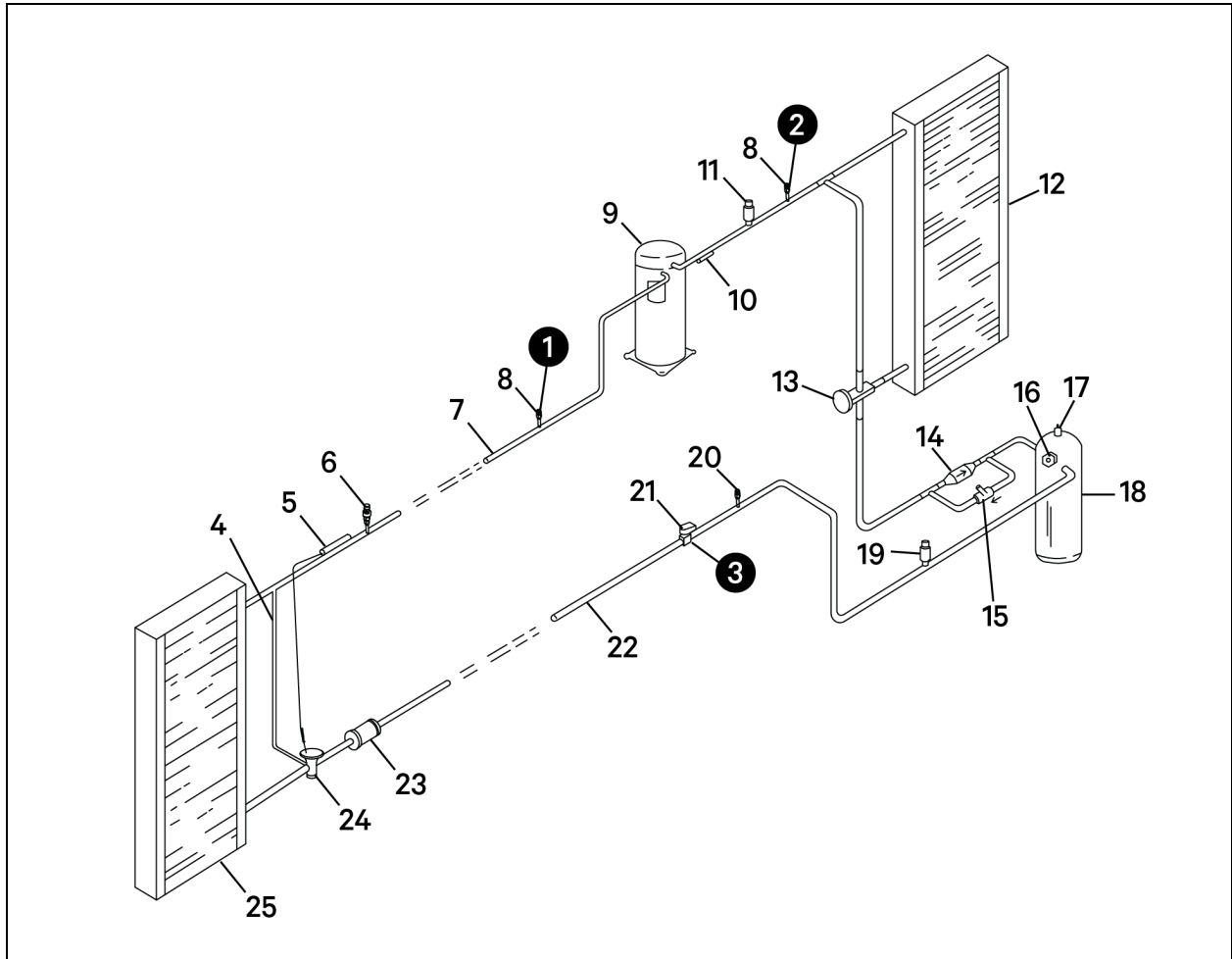

Item	Description
1	Apply a manifold gauge hose on the suction-line Schraderport.
2	Apply a manifold gauge hose on the discharge-line Schrader port.
3	Remove the solenoid-valve holding coil then apply solenoid-valve service magnet to the valve.
4	External equalizer
5	Sensing bulb
6	Suction-pressure transducer
7	Suction line
8	Schrader port with valve core
9	Digital scroll compressor

Item	Description
10	Discharge-temperature thermistor
11	High pressure switch
12	Condenser coil
13	3-way head pressure control valve
14	Check valve
15	Pressure-balancing valve
16	Sight glass
17	Pressure-relief valve
18	Liebert® Lee-Temp receiver
19	Receiver-heater pressure-limiting switch
20	Schrader port with valve core NOTE: The system includes a factory installed Schrader valve with core in the liquid line downstream of the receiver. Proper evacuation of the condenser side of the system can be accomplished only using the downstream Schrader valve. See the appropriate piping schematic for your system in Submittal Drawings on page 39 .
21	Liquid-line solenoid valve
22	Liquid line
23	Filter drier
24	Expansion valve
25	Evaporator coil

To evacuate and leak test the system:

1. Open the liquid-line solenoid valve by removing the holding coil, and apply a solenoid-valve service magnet to the valve.
2. Connect manifold-gauge hoses on the discharge- and suction-line Schrader ports, open the service valves, and place a 150 psig (1034 kPa) charge of dry nitrogen with a tracer of refrigerant, then check the system for leaks with a suitable leak detector.
3. After completion of leak testing, release the test pressure. (observe local code) and pull an initial deep vacuum of 500 microns on the system with a suitable pump.
4. After 4 hours, check the pressure readings and, if they have not changed, break vacuum with dry nitrogen. Pull a second and third vacuum to 500 microns or less. Re-check the pressure after 2 hours.
When the 3 checks are complete, proceed to charging air cooled system.

Break Vacuum

Using a manifold charging hose equipped with a ball valve, properly connect to a tank of refrigerant, and purge the hose with refrigerant to ensure non-condensable do not enter the system. Connect the hose assembly to the liquid line Schrader port and break circuit vacuum with a portion of the calculated refrigerant pre-charge. Add enough refrigerant to bring pressure slightly above positive. Close ball valve and remove refrigerant tank.

Charging Air Cooled Systems

NOTICE

Risk of improper refrigerant charging. Can cause equipment damage.

R-410A is a blended refrigerant and must be introduced and charged from the cylinder only as a liquid.

Care must be exercised to avoid damage to the compressor. We recommend connecting a manifold charging hose equipped with a ball valve to the liquid line Schraeder port.

NOTICE

Risk of improper component re-installation. Can cause equipment damage.

Identify and mark location of the discharge pressure switch. It must be reinstalled in its original location.

NOTICE

Units should never be operated with no refrigerant charge, holding charge, proper load, or without additional oil as required. Tag out system to prevent unauthorized personnel from accidentally starting equipment and damaging compressors if any of these conditions exist.

Initially charging the system:

- Check the nameplate on the indoor unit for refrigerant type to use.
- Refer to [Refrigerant Charge Requirements](#) on page 15, and calculate the amount of charge for the system including the evaporator, condensing unit, and interconnecting piping.
- Add additional compressor and trap oil. See [Additional Oil Requirements for Digital Scroll Compressors](#) on page 17
- Accurately weigh-in as much of the system charge as possible before re-installing the coil on the liquid-line solenoid valve and starting the unit.

NOTICE

The unit must have line voltage applied to the unit at least 12 hours before compressor start-up to allow the compressor crankcase heaters time to warm the compressors and boil off any liquid refrigerant in the compressors after pre-charge.

Apply manifold gauges to suction and discharge service valves on circuit 1. Open Service valves on compressor.

Field Charge Verification

The unit receiver includes an integral sight glass to assist with charge verification in the field.

To verify the refrigerant charge:

1. To keep the unit operating, use the Service menu at the Vertiv™ Liebert® iCOM™ touchscreen control:
 - Touch the *Service* icon to display the service menu, then touch *Diagnostics/Service*.
 - Touch the *Compressor Circuit* options, and select *2* (charge mode) in the Compressor Mode field. The compressor runs at 100% for 30 minutes in charge mode.

2. At design ambient temperature between 95°F and 105°F (35°C and 41°C), the charge level should be in the middle of the sight glass.
 - If the charge level is below the sight glass, an under charge condition is likely.
 - If the charge level is above the sight glass, and you observe a higher than normal discharge pressure, an over-charge condition is likely. However, before removing charge, make sure that there are no other possible causes of high discharge pressure such as a dirty coil or restricted air flow.
3. Below design ambient temperatures, refrigerant backs-up into the condenser coil and the charge level drops below the sight glass. At lower ambient temperatures, block the condenser coil to maintain 418 psig (2882 kPa) discharge pressure to ensure that the head pressure control valve is closed. The charge level should be in the middle of the sight glass with the valve closed.
 - If the charge level is below the sight glass, an under charge condition is likely.
 - If the charge level is above the sight glass, an over charge condition is likely.

NOTE: In systems with two condenser coils and two receivers, block-off coils proportionally. If one coil is restricted significantly more than the other, liquid can remain in the restricted coil causing lower levels in the receiver. The liquid level should be in the middle of the sight glass in both receivers. There may be some variation in charge level between the receivers. When adding charge, use the receiver showing a lower charge level and use that sight glass to determine the charge level.

4. If no level is visible in the sight glass, add charge until the level is in the middle of the glass. Check the discharge pressure and adjust the coil restrictions to maintain 418 psig (2882 kPa).
5. After conditions have stabilized, restrict the coil, if required, to maintain 418 psig (2882 kPa) discharge pressure and verify that the charge level is in the middle of the sight glass.

Additional Compressor Oil

Once the circuits are topped off with refrigerant, more compressor oil may need to be added to each circuit if the final charge is over 10 pounds of the calculated refrigerant charge. Record this additional oil amount on the manilla tag hanging on the compressor service valve.

Documenting Refrigerant Charge and Oil Addition

When the unit is charged, you must record the total system refrigerant charge value on the condensing unit's serial tag. The total system charge includes the evaporator, condensing unit, and interconnecting lines, plus any adjustments made during the field-charge verification step.

On the tag marked "Oil Added Field Service Record," attached to each compressor, record the date the oil was added and the amount of oil added.

5 Electrical Connection Requirements



WARNING! Arc flash and electric shock hazard. Open all local and remote electric power supply disconnect switches, verify with a voltmeter that power is Off and wear appropriate, OSHA-approved personal protective equipment (PPE) per NFPA 70E before working within the electric control enclosure. Failure to comply can cause serious injury or death. Customer must provide earth ground to unit, per NEC, CEC and local codes, as applicable. Before proceeding with installation, read all instructions, verify that all the parts are included and check the nameplate to be sure the voltage matches available utility power. The Vertiv™ Liebert® iCOM™ controller does not isolate power from the unit, even in the “Unit Off” mode. Some internal components require and receive power even during the “Unit Off” mode of the controller. The only way to ensure that there is NO voltage inside the unit is to install and open a remote disconnect switch. Refer to unit electrical schematic. Follow all local codes.



WARNING! Risk of improper wire sizing/rating and loose electrical connections. Can cause overheated wire and electrical connection terminals resulting in smoke, fire, equipment and building damage, injury or death. Use correctly sized copper wire only and verify that all electrical connections are tight before turning power On. Check all electrical connections periodically and tighten as necessary.

NOTICE

Risk of improper electrical connection of three-phase input power. Can cause backward compressor rotation and unit damage. Service technicians should use a gauge set on the system during the initial start up to verify that the three-phase power is connected properly. Three-phase power must be connected to the unit line voltage terminals in the proper sequence so that the compressors rotate in the proper direction. Incoming power must be properly phased to prevent compressors from running backward. We recommend checking the unit's phasing with proper instrumentation to ensure that power connections were made correctly. We also recommend verifying discharge and suction pressures during start up to ensure that the compressors are running in the correct direction.

NOTICE

Risk of compressor slugging. Can cause equipment damage.

Apply power to the condensing unit 8 hours before operating the system. This time is required to drive liquid refrigerant out of the compressor. This is especially important at low ambient temperatures. The compressor's crank-case heater is energized as long as power is supplied to the unit.

NOTICE

Risk of improper power supply connection. Can cause equipment damage and loss of warranty coverage.

Prior to connecting any equipment to a main or alternate power source (for example: back-up generator systems) for startup, commissioning, testing, or normal operation, ensure that these sources are correctly adjusted to the nameplate voltage and frequency of all equipment to be connected. In general, power-source voltages should be stabilized and regulated to within $\pm 10\%$ of the load nameplate nominal voltage. Also, ensure that no three-phase sources are single-phased at any time.

See transformer label for primary tap connections. Installer will need to change transformer primary taps if applied unit voltage is other than pre-wired tap voltage.

Electrical service is required for all models. All power and control wiring and ground connections must be in accordance with the National Electrical Code and local codes. Refer to the equipment serial-tag data for electrical requirements.

A field supplied, manual, electrical-disconnect switch should be installed in accordance with local codes and distribution system. Consult local codes for external disconnect requirements.

NOTE: Input-power requirements: For 3-phase units, only 3 power wires and an earth ground are required.

Each unit is shipped from the factory with internal wiring completed. Refer to the electrical schematic when making connections.

The electrical connections are described in the submittal documents included in the [Submittal Drawings](#) on page 39.

The following table lists the relevant documents by number and title.

Table 5.1 Electrical Field Connection Drawings

Document Number	Title
DPN004168	Electrical Field Connections, top discharge.
DPN004169	Electrical Field Connections, horizontal discharge.

5.1 Low Voltage, Control Connections

A field supplied, shielded, 6-wire control connection (24 VAC) is required between the evaporator and the condensing unit.

Control wiring must be installed in accordance with the National Electrical Code (NEC) Class 1 or Class 2 circuit according to wire-routing conditions chosen and local codes.

Low voltage wiring should be sized to allow a 1-Volt maximum drop due to line resistance between the evaporator and condensing unit. Use NEC Class 1 or 2 wiring according to wire routing conditions chosen and local codes, sizing wire per maximum wire lengths using **Table 5.2** below. Connect the shield wire to earth (ground) at the Liebert® equipment. Avoid running the low voltage connections near high voltage lines or loads such as light ballasts.

NOTE: Do not connect additional electrical devices to the control circuit. The internal control transformer is only sized for factory supplied components. Refer to the appropriate submittal drawings for your system for electrical connections. See **Table 5.1 above.**

Table 5.2 Recommended Minimum Wire Size Between Indoor and Outdoor Units

Max. Distance, * ft (m)	Min. Wire Gauge, AWG (mm2)
50 (15)	20 (0.75)
100 (30)	18 (1.0)
150 (45)	16 (1.5)

* One-way control wire run between outdoor condensing unit and evaporator.

6 Checklist for Completed Installation

1. All items are unpacked and checked.
2. Proper clearances for service access have been maintained around the equipment.
3. Equipment is level and mounting fasteners are tight.
4. Piping completed to refrigerant loop.
5. All piping connections are leak-free.
6. Piping is routed to prevent chafing and rub-through.
7. System was evacuated and refrigerant charge and any necessary oil charge added.
8. Line voltage to power wiring matches equipment serial tag.
9. Power wiring connections completed including earth ground.
10. Power-line circuit breakers or fuses have proper ratings for equipment installed.
11. Control wire to condensing unit is shielded, connections completed, including shield wire connected to earth (ground) at Liebert units.
12. All wiring connections are tight.
13. Foreign materials have been removed from inside and around all equipment installed (shipping materials, construction materials, tools, etc.)
14. Fan rotates freely.
15. Fan and compressor are rotating in the correct direction.
16. Blank startup sheet included with the condensing unit is ready for completion by installer.

This page intentionally left blank

7 Initial Start-up Checks and Commissioning Procedure for Warranty Inspection



WARNING! Arc flash and electric shock hazard. Open all local and remote electric power supply disconnect switches, verify with a voltmeter that power is Off and wear appropriate, OSHA-approved personal protective equipment (PPE) per NFPA 70E before working within the electric control enclosure. Failure to comply can cause serious injury or death. Customer must provide earth ground to unit, per NEC, CEC and local codes, as applicable. Before proceeding with installation, read all instructions, verify that all the parts are included and check the nameplate to be sure the voltage matches available utility power. The Vertiv™ Liebert® iCOM™ controller does not isolate power from the unit, even in the “Unit Off” mode. Some internal components require and receive power even during the “Unit Off” mode of the controller. The only way to ensure that there is NO voltage inside the unit is to install and open a remote disconnect switch. Refer to unit electrical schematic. Follow all local codes.



WARNING! Risk of improper wiring, piping, moving, lifting and handling. Can cause equipment damage, serious injury or death. Installation and service of this equipment should be done only by qualified personnel who have been specially-trained in the installation of air-conditioning equipment and who are wearing appropriate, OSHA-approved PPE.

NOTICE

Risk of improper electrical connection of three-phase input power. Can cause backward compressor rotation and unit damage. Service technicians should use a gauge set on the system during the initial start up to verify that the three-phase power is connected properly. Three-phase power must be connected to the unit line voltage terminals in the proper sequence so that the compressors rotate in the proper direction. Incoming power must be properly phased to prevent compressors from running backward. We recommend checking the unit’s phasing with proper instrumentation to ensure that power connections were made correctly. We also recommend verifying discharge and suction pressures during start up to ensure that the compressors are running in the correct direction.

- Confirm that all items on [Checklist for Completed Installation](#) have been done.
- Locate “Liebert® PFD Warranty Inspection Check Sheet” in the unit’s electric panel. (PSWI-8542-438RE)
- Complete “Liebert® PFD Warranty Inspection Check Sheet” during start-up. (PSWI-8542-438RE)
- Forward the completed “Liebert® PFD Warranty Inspection Check Sheet” to your local sales office. **This information must be completed and forwarded to validate warranty.**
- Contact your local sales representative or technical support if you have any questions or problems during unit start-up and commissioning. Visit <https://www.Vertiv.com/en-us/support/> or call 1-800-543-2778 for contacts.

Local sales offices and product support contacts can be found at <https://www.Vertiv.com/en-us/support/> or 1-800-543-2778.

This page intentionally left blank

8 Maintenance



WARNING! Arc flash and electric shock hazard. Open all local and remote electric power supply disconnect switches, verify with a voltmeter that power is Off and wear appropriate, OSHA-approved personal protective equipment (PPE) per NFPA 70E before working within the electric control enclosure. Failure to comply can cause serious injury or death. Customer must provide earth ground to unit, per NEC, CEC and local codes, as applicable. Before proceeding with installation, read all instructions, verify that all the parts are included and check the nameplate to be sure the voltage matches available utility power. The Vertiv™ Liebert® iCOM™ controller does not isolate power from the unit, even in the “Unit Off” mode. Some internal components require and receive power even during the “Unit Off” mode of the controller. The only way to ensure that there is NO voltage inside the unit is to install and open a remote disconnect switch. Refer to unit electrical schematic. Follow all local codes.



WARNING! Risk of electric shock. Can cause equipment damage, injury or death. Open all local and remote electric power supply disconnect switches and verify with a voltmeter that power is off before working within any electric connection enclosures. Service and maintenance work must be performed only by properly trained and qualified personnel and in accordance with applicable regulations and manufacturers’ specifications. Opening or removing the covers to any equipment may expose personnel to lethal voltages within the unit even when it is apparently not operating and the input wiring is disconnected from the electrical source.



WARNING! Risk of improper wiring, piping, moving, lifting and handling. Can cause equipment damage, serious injury or death. Installation and service of this equipment should be done only by qualified personnel who have been specially-trained in the installation of air-conditioning equipment and who are wearing appropriate, OSHA-approved PPE.



WARNING! Risk of contact with high speed rotating fan blades. Can cause serious injury or death. Open all local and remote electric power supply disconnect switches, verify with a voltmeter that power is off, and verify that all fan blades have stopped rotating before working in the unit cabinet or on the fan assembly. If control voltage is applied, the fan motor can restart without warning after a power failure. Do not operate the unit with any or all cabinet panels removed.



CAUTION: Risk of contact with hot surfaces. Can cause injury. The compressor, refrigerant discharge lines, fan motor, and some electrical components are extremely hot during unit operation. Allow sufficient time for them to cool to a touch-safe temperature before working within the unit cabinet. Use extreme caution and wear appropriate, OSHA-approved PPE when working on or near hot components.

The Vertiv™ Liebert® PFD units are single components in the facility heat-removal system. The system includes evaporator, air distribution (duct systems), outdoor heat rejection (condensing unit) and indoor cooling and humidity loads (equipment load, location, outside air infiltration). Proper application and maintenance of the entire system is critical to the life and reliability of the thermal-management units.

- Good maintenance practices are essential to minimizing operation costs and maximizing product life.
- Read and follow monthly and semi-annual maintenance schedules included in this manual. These MINIMUM maintenance intervals may need to be more frequent based on site-specific conditions.
- See the Vertiv™ Liebert® iCOM™ user manual for instructions on using the controller to predict some service maintenance intervals.
- We recommend the use of trained and authorized service personnel, extended service contracts and factory specified replacement parts. Contact your Vertiv™ sales representative.

8.1 General Maintenance



WARNING! Arc flash and electric shock hazard. Open all local and remote electric power disconnect switches, verify with a voltmeter that power is Off and wear personal protective equipment (PPE) per NFPA 70E before working within the electric control enclosure. Failure to comply can cause serious injury or death. The Vertiv™ Liebert® iCOM™ controller does not isolate power from the unit, even in the “Unit Off” mode. Some internal components require and receive power even during the “Unit Off” mode of the controller. The only way to ensure that there is NO voltage inside the unit is to install and open a remote disconnect switch. Refer to unit electrical schematic. Follow all local codes.

NOTICE

Risk of compressor slugging. Can cause equipment damage.

Apply power to the condensing unit 8 hours before operating the system. This time is required to drive liquid refrigerant out of the compressor. This is especially important at low ambient temperatures. The compressor's crank-case heater is energized as long as power is supplied to the unit.

Access the condensing unit by removing the unit housing panel.

- Clean the air cooled condenser coil of all debris that will inhibit airflow. This can be done with compressed air, with water from a garden hose, or with a commercial coil cleaner.
- Check for bent or damaged coil fins and repair as necessary.
- During winter, do not permit snow to accumulate on or around the condensing unit.
- Check all refrigerant lines and capillaries for vibration isolation and support as necessary.
- Check all refrigerant lines for signs of leaks.

8.2 Compressor Maintenance



WARNING! Risk of over-pressurization of the refrigeration system. Can cause explosive discharge of high-pressure refrigerant, loss of refrigerant, environmental pollution, equipment damage, injury, or death. This unit contains fluids and gases under high pressure. Use extreme caution when charging the refrigerant system. Do not pressurize the system higher than the design pressure marked on the unit's nameplate. Relieve pressure before cutting into or making connections/disconnections to the piping system.

8.2.1 Compressor Oil

NOTICE

Risk of improper compressor lubrication. Can cause compressor and refrigerant system damage.

Failure to use oil types, viscosities and quantities recommended by the compressor manufacturer may reduce compressor life and void the compressor warranty.

- Do not mix polyolester (POE) and mineral-based oils.
- Do not mix oils of different viscosities.
- Consult Vertiv™ technical support or the compressor manufacturer if questions arise.

Table 8.1 Compressor Oil Types for R-410A Refrigerant

Compressor Type	Oil Type
Copeland Scroll and Digital Scroll	POE Oil - ISO 32 Centistoke Viscosity ¹
¹ Use Copeland POE Oil UL TRA 32-3MAF or other Copeland-approved oils.	
Source: DPN003950. Rev. 6	

8.2.2 Replacement Compressors

Replacement compressors are available through your Vertiv™ sales office. If the unit is under warranty, the replacement compressor must be obtained from and the original compressor returned to your local Vertiv™ sales office. Compressors are shipped in reusable packaging, and the original compressor should be returned in the same packaging.

8.2.3 Compressor Electrical Failure (Motor Burnout)

If a burnout has occurred, a full system clean-out is required. If not cleaned, compressor and system problems will continue.

Consult the factory for compressor maintenance. Do not attempt to remove the compressor without first contacting Vertiv™ support at 1-800-543-2778.

8.2.4 Unloading Solenoid(s) on a Digital scroll Compressor

When replacing a digital scroll compressor, the digital solenoid valve and coil must be replaced. The compressor and valve kit are shipped separately. The valve kit must be field-brazed to the top of the compressor in proper orientation and supported with the original factory bracket.

8.2.5 Replacing the Compressor



WARNING! Risk of electric shock. Can cause serious injury or death. The Vertiv™ Liebert® iCOM™ microprocessor does not isolate power from the unit, even in the "Unit Off" mode. Some internal components require and receive power even during the "Unit Off" mode of the Liebert® iCOM™ control. Open all local and remote electric power disconnect switches and verify with a voltmeter that power is Off before working on any component of the system.



WARNING! Risk of over-pressurization of the refrigeration system. Can cause explosive discharge of high-pressure refrigerant, loss of refrigerant, environmental pollution, equipment damage, injury, or death. This unit contains fluids and gases under high pressure. Use extreme caution when charging the refrigerant system. Do not pressurize the system higher than the design pressure marked on the unit's nameplate. Relieve pressure before cutting into or making connections/disconnections to the piping system. Do not close off any field installed, refrigerant-line isolation valves for repairs unless a pressure-relief valve is field installed in the line between the isolation valve and the check valve. The pressure-relief valve must be rated 5% to 10% higher than the system-design pressure. An increase in ambient temperature can cause the pressure of the isolated refrigerant to rise and exceed the system-design pressure rating (marked on the unit nameplate).

NOTICE

Risk of improper component re-installation. Can cause equipment damage.

Identify and mark location of the discharge pressure switch. It must be reinstalled in its original location.

NOTE: Failure to properly clean the system after compressor-motor burnout voids the compressor warranty. Follow the manufacturer's procedure.

NOTE: Release of refrigerant to the atmosphere is harmful to the environment. Refrigerant must be recycled or discarded in accordance with federal, state and local regulations.

1. Disconnect power.
2. Attach suction and discharge gauges to access fittings.
3. Recover refrigerant using an approved recovery procedure and equipment. Use a filter drier when charging the system with recovered refrigerant.
4. Remove the temperature thermistor from the discharge line and make a note of its location because you will need to re install it.
5. Unsweat refrigerant connections and disconnect all electrical connections.
6. Remove failed compressor.

7. Install replacement compressor and make all connections.
8. Re-install the temperature thermistor at its original location (noted in step 4), which is within 6 inches (152 mm) of the compressor connection, and insulate making sure that the bulb makes good contact with the discharge line.
9. Pressurize and leak test the system.
10. Follow compressor manufacturer's suggested clean-out procedures..
11. After completion of leak testing, release the test pressure, (observe local code) and pull an initial deep vacuum of 500 microns on the system with a suitable pump.
12. After 4 hours, check the pressure readings and, if they have not changed, break vacuum with dry nitrogen. Pull a second and third vacuum to 500 microns or less, and verify that the vacuum levels are maintained.
13. With the system in a 500 microns or lower vacuum, charge the system based on the requirements listed in [Refrigerant Charge Requirements](#) on page 15 .

8.3 Condensing Unit Maintenance

Restricted airflow will reduce operating efficiency and could result in high compressor-head pressure and loss of cooling.

- Clear coil surface of all debris that will inhibit airflow.
- Check for bent or damaged coil fins and correct.
- Do not permit snow to accumulate around or under outdoor unit.
- Periodically consider commercial cleaning of coil surface
- Inspect fans, motors and controls for proper operation.
- Check all piping and capillaries for proper support.
- Inspect for leaks.
- Check contactors for pitting. Replace if pitted.

This page intentionally left blank

9 Troubleshooting

Table 9.1 on the next page, lists problems you may encounter, the possible cause, and a suggested remedy.

Table 9.1 Troubleshooting

Problem	Cause	Remedy
Unit will not start	No power to unit	Check voltage at input terminal block.
	Compressor contactor not pulling in	<p>Check for 24 VAC \pm2 VAC at control connections 1 & 2.</p> <p>If there is voltage, then:</p> <ul style="list-style-type: none"> Check 24 VAC at control connections 3 and 6. If there is voltage, then there is compressor high discharge pressure situation. The compressor will attempt to start once the high pressure situation has resolved. Check 24 VAC at control connections 5 and 6. If there is no voltage, then there is high discharge temperature situation. The compressor will attempt to start once the high temperature situation has resolved and minimum 30 min have elapsed. <p>If there is no voltage between 1 & 2, then:</p> <ul style="list-style-type: none"> Check control settings for cooling requirement. Check 24 VAC at control connections 3 and 6. If there is voltage, there is compressor lock-out due to high discharge pressure condition. Check display for high pressure alarm. Set S302 to 0 or recycle power to indoor unit. Check 24 VAC at control connections 5 and 6. If there is no voltage, there is compressor lock-out due to high discharge temperature condition. Check display for high temperature alarm. Set S303 to 0 or recycle power to indoor unit.
	Control voltage fuses (at transformer in evaporator module) open	Locate short and replace fuses.
	Short cycle prevention control	Control software delays compressor 3 minutes from stop to start.
	Compressor high discharge pressure/ lockout relay	Check for 24VAC \pm 2VAC at control connections 2 & 3. Remove 24VAC signal at Connection 2 by turning indoor unit control off, then back on, or by raising the setpoint to remove the cab for cooling, then resetting to re-establish operation.
	High discharge pressure	Insufficient air flow across condenser coil
Low discharge pressure	High refrigerant charge	Check refrigerant charge.
	Faulty head pressure control valve	Replace if defective.
Low suction pressure/compressor cycling	Compressor rotation in reverse direction	Check for proper power phase wiring to unit and to compressor motor.
	Insufficient refrigerant in system	Check for leaks; repair and add refrigerant.
	Plugged filter drier	Replace filter drier.
	Improper superheat adjustment	Reset expansion valve for 10°F to 15°F (5.6°C to 8.4°C) superheat at evaporator.
	Defective liquid line solenoid valve	Check valve and coil; replace if necessary.

Table 9.1 Troubleshooting (continued)

Problem	Cause	Remedy
Low compressor capacity/ no cooling	Defective liquid line solenoid valve	Check valve and coil; replace if necessary.
	Plugged filter drier	Check pressure drop across filter drier. Replace filter drier.
	Low refrigerant charge	Check for normal system operating pressures. Refer to abnormal pressure causes if applicable. Check for leaks. Proper refrigerant charge is very important at low ambient operation.
Compressor noisy	Loose compressor or piping support	Tighten clamps.
	Compressor rotation in reverse direction	Check for proper power phase wiring to unit and to compressor motor.
Pipe Rattle	Loose pipe connections	Check pipe connections and supports.
Compressor running hot	Compression ratio too high	Check for normal system operating pressures. Refer to abnormal pressure causes if applicable.
Compressor motor protectors tripping or cycling	High discharge pressure	Check for blocked condenser fan or coil.
	High suction temperature	Check expansion valve and hot gas bypass valve setting. Check liquid quenching valve operation.
	Loose power or control circuit wiring connection	Check all power and control circuit connections.
	Defective motor	Check for motor ground or short. Replace compressor if either condition is found.
Compressor cycles on locked rotor	Low line voltage	Check line voltage and determine location of voltage drop.
	Compressor motor defective	Check for motor winding short or ground.
	Single phasing	Check voltage across all 3 legs at contactor. Correct source of problem.
Motor burnout	Check control panel for welded contactor contacts or welded overload contacts.	Replace defective components.

Appendices

Appendix A: Technical Support and Contacts

A.1 Technical Support/Service in the United States

Vertiv Corporation

24x7 dispatch of technicians for all products.

1-800-543-2378

Liebert® Thermal Management Products

1-800-543-2378

Liebert® Channel Products

1-800-222-5877

Liebert® AC and DC Power Products

1-800-543-2378

A.2 Locations

United States

Vertiv Headquarters

505 N. Cleveland Ave.

Westerville, OH 43082, USA

Europe

Via Leonardo Da Vinci 8 Zona Industriale Tognana

35028 Piove Di Sacco (PD) Italy

Asia

7/F, Dah Sing Financial Centre

3108 Gloucester Road

Wanchai, Hong Kong

This page intentionally left blank

Appendix B: Submittal Drawings

The submittal drawings are in the order of document part number (DPN). **Table B.1** below, groups the drawings by topic/application.

Table B.1 Submittal Drawings Contents

Document Number	Title
PFD Component Location	
DPN004180	Vertiv™ Liebert® PFD Condensing Unit, 3-, 4-, and 5-ton
PFD Planning Dimensions	
DPN004058	Cabinet dimensions, 5-ton, top discharge
DPN004063	Cabinet dimensions, 3-, 4-, and 5-ton, horizontal discharge
DPN004066	Optional anchoring plan, 3-, 4-, and 5-ton, horizontal discharge
PFD Piping Schematics	
DPN004060	Piping arrangement, 3-, 4- and 5-ton split-system
DPN004062	Piping arrangement, Condensing unit
PFD Piping Connections	
DPN004059	Primary connection locations, top discharge
DPN004064	Primary connection locations, horizontal discharge
PFD Electrical Connections	
DPN004168	Electrical Field Connections, top discharge
DPN004169	Electrical Field Connections, horizontal discharge

COMPONENT LOCATION DIAGRAM TYPICAL HORIZONTAL DISCHARGE CONDENSING UNIT

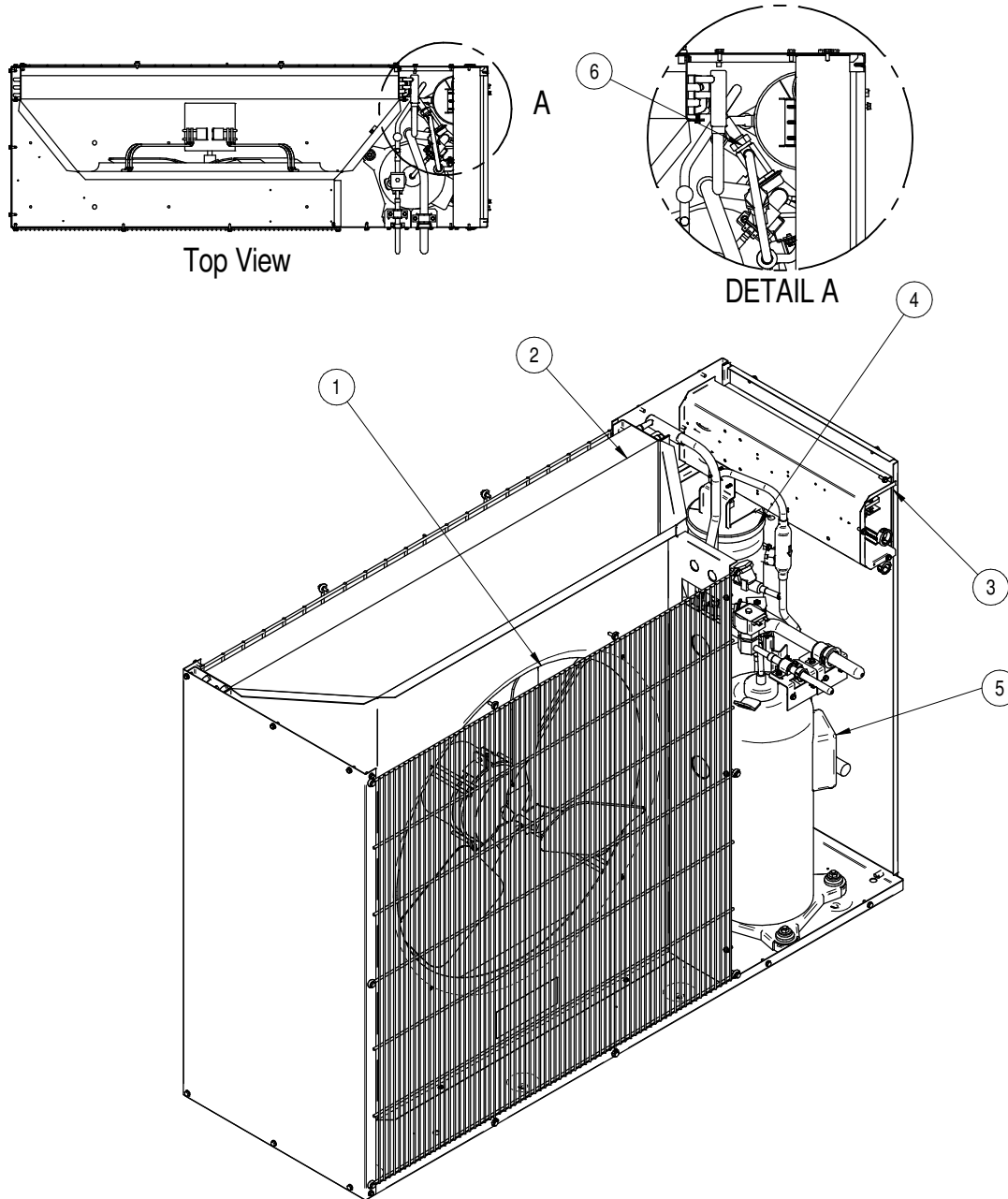

- 1 Fan with Direct-drive motor
- 2 Condenser coil
- 3 Electric box
- 4 Heated Receiver
- 5 Variable-Capacity Digital Scroll Compressor
- 6 Head Pressure Control Valve (Liebert® Lee-Temp)

CABINET DIMENSIONAL DATA
5 TON HIGH AMBIENT/QUIET-LINE OUTDOOR CONDENSING UNIT
TOP AIR DISCHARGE

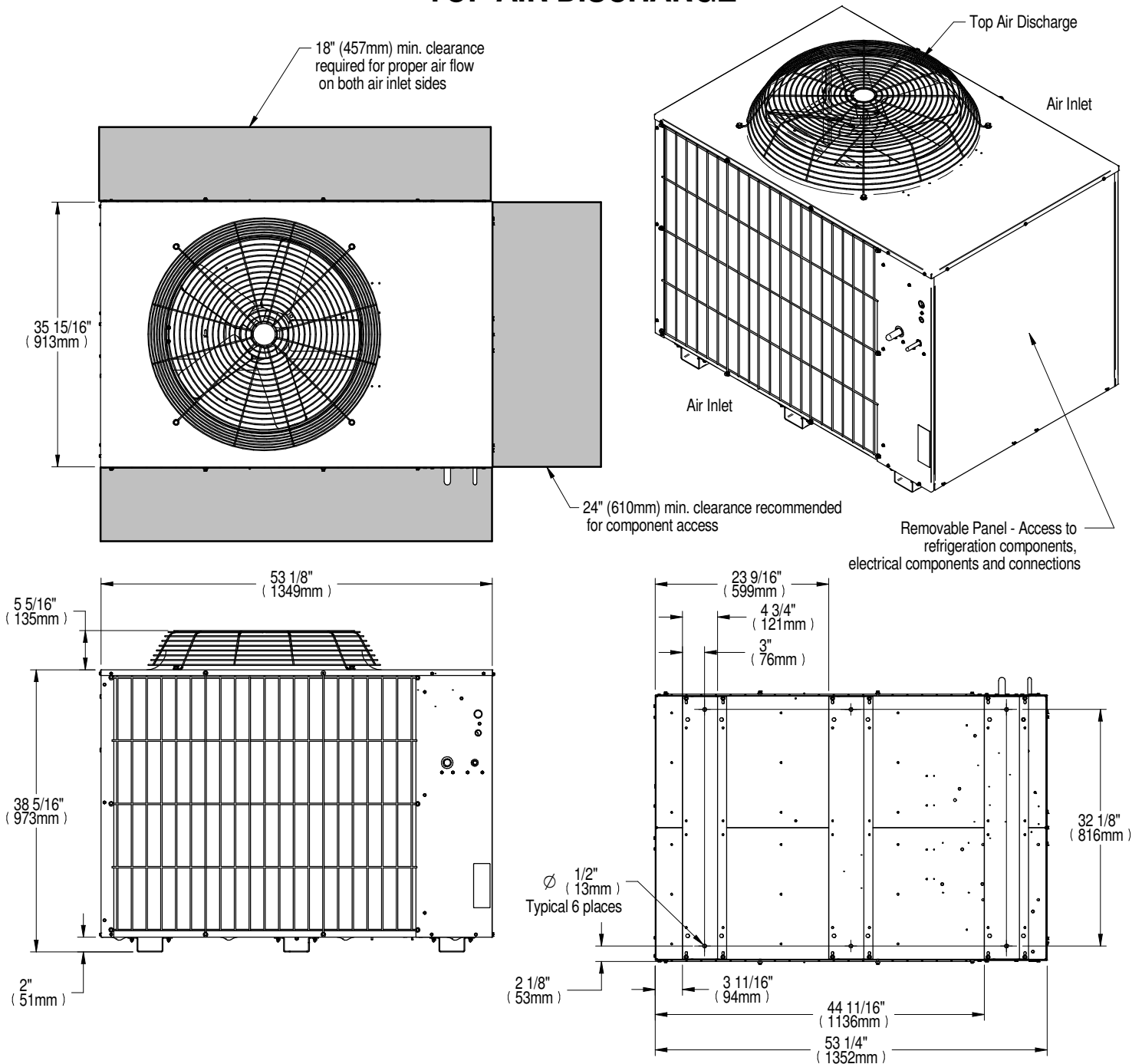

Anchorage Plan
 Bottom View of Unit

MODEL	MODULE WEIGHT
60Hz	lbs. (kg) net
PFD067A-H	488 (222)
PFDZ67A-L	

CABINET DIMENSIONAL DATA
OUTDOOR CONDENSING UNIT W/ HORIZONTAL AIR DISCHARGE

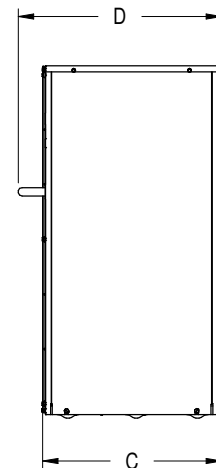
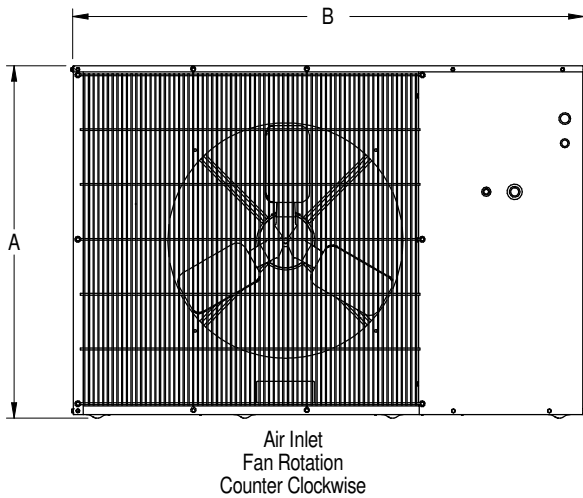
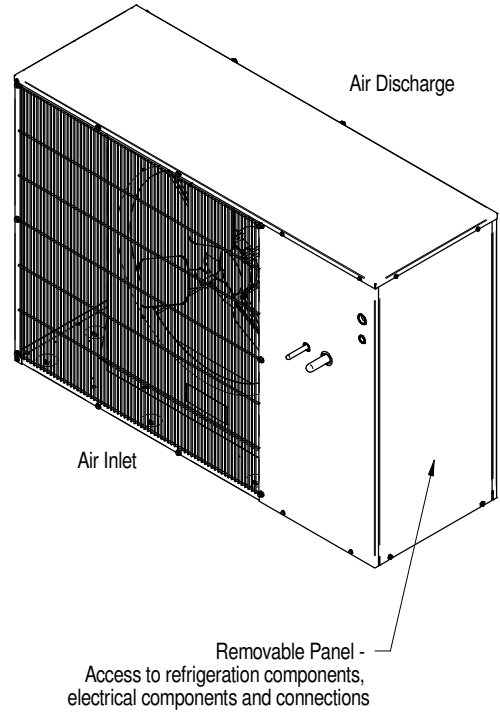
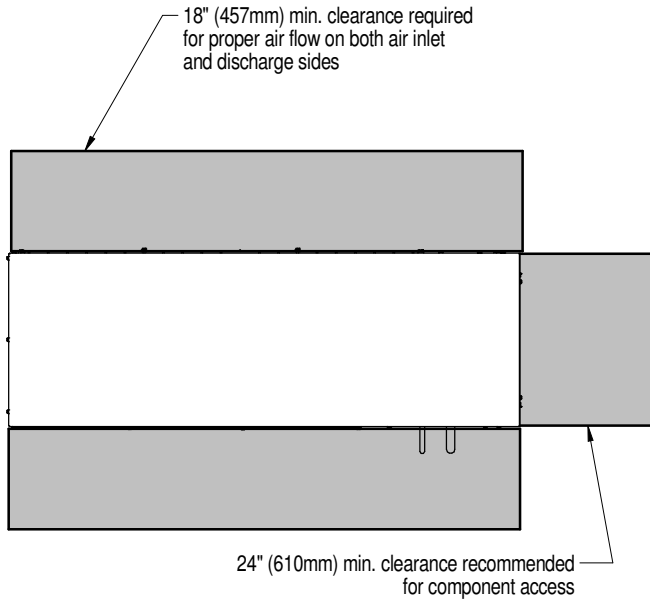

MODEL NUMBERS	UNIT NET WEIGHT lbs. (kg)	DIMENSIONAL DATA in. (mm)			
		A	B	C	D
PFD037A-L	244 (111)	30-3/4 (781)	48-1/4 (1225)	18-5/8 (473)	21-1/4 (540)
PFD037A-H	351 (159)	36-3/4 (933)	53-1/4 (1352)	18-5/8 (473)	21-1/4 (540)
PFD054A-L					
PFD067A-L					

OPTIONAL ANCHORAGE PLAN OUTDOOR CONDENSING UNIT WITH HORIZONTAL AIR DISCHARGE

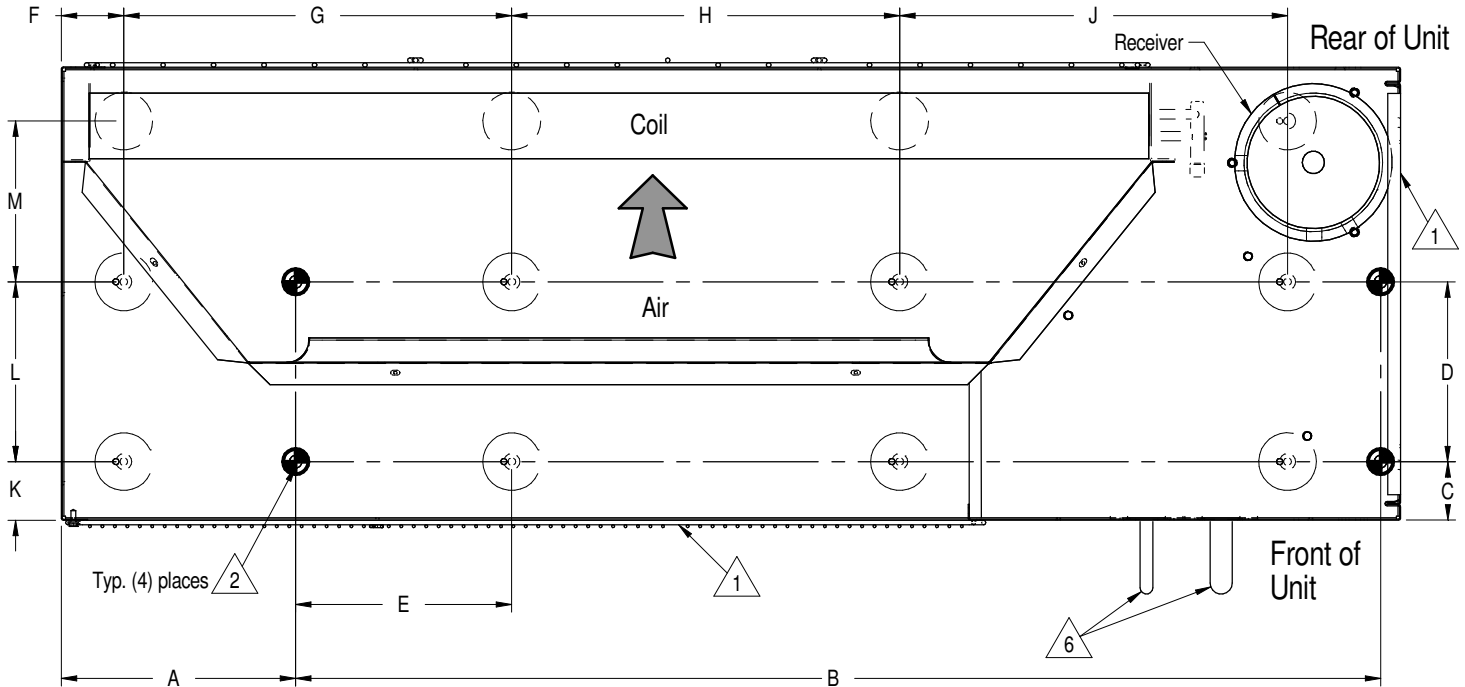

TOP VIEW
Some Parts not Shown for Clarity

MODEL NUMBERS	DIMENSIONAL DATA in. (mm)											
	A	B	C	D	E	F	G	H	J	K	L	M
PFD037A-L	9-9/16 (243)	37-1/8 (943)	2-1/4 (57)	7-1/8 (181)	6-1/8 (156)	2-9/16 (65)	13-1/8 (333)	14-3/4 (375)	13-1/4 (337)	2-1/4 (57)	7-1/8 (181)	6-3/8 (162)
PFD037A-H												
PFD054A-L	9-5/16 (236)	43 (1092)	2-5/16 (58)	7-1/8 (181)	8-19/16 (217)	2-1/2 (63)	15-1/16 (383)	15-11/16 (398)	15-3/8 (391)	2-5/16 (58)	7-1/8 (181)	6-3/8 (162)
PFD067A-L												

Notes:

1. Front Grille and Right End Panel will need to be removed to access anchor holes. Top panel may be removed for additional access. All removed parts must be reinstalled.
2. 1/2" (13mm) Diameter hole, use for unit anchor.
3. All dimensions have a tolerance of $\pm 1/16"$.
4. F, G, H, J, K, L and M dimensions are for the foot locations.
5. The use of this anchor plan is optional and installer will assume responsibility for suitable anchorage.
6. Supply and return piping connections.

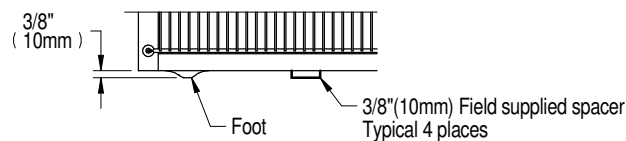

PARTIAL FRONT VIEW



LIEBERT® MINI-MATE VARIABLE CAPACITY

GENERAL ARRANGEMENT SPLIT SYSTEMS W/ AIR COOLED CONDENSING UNIT

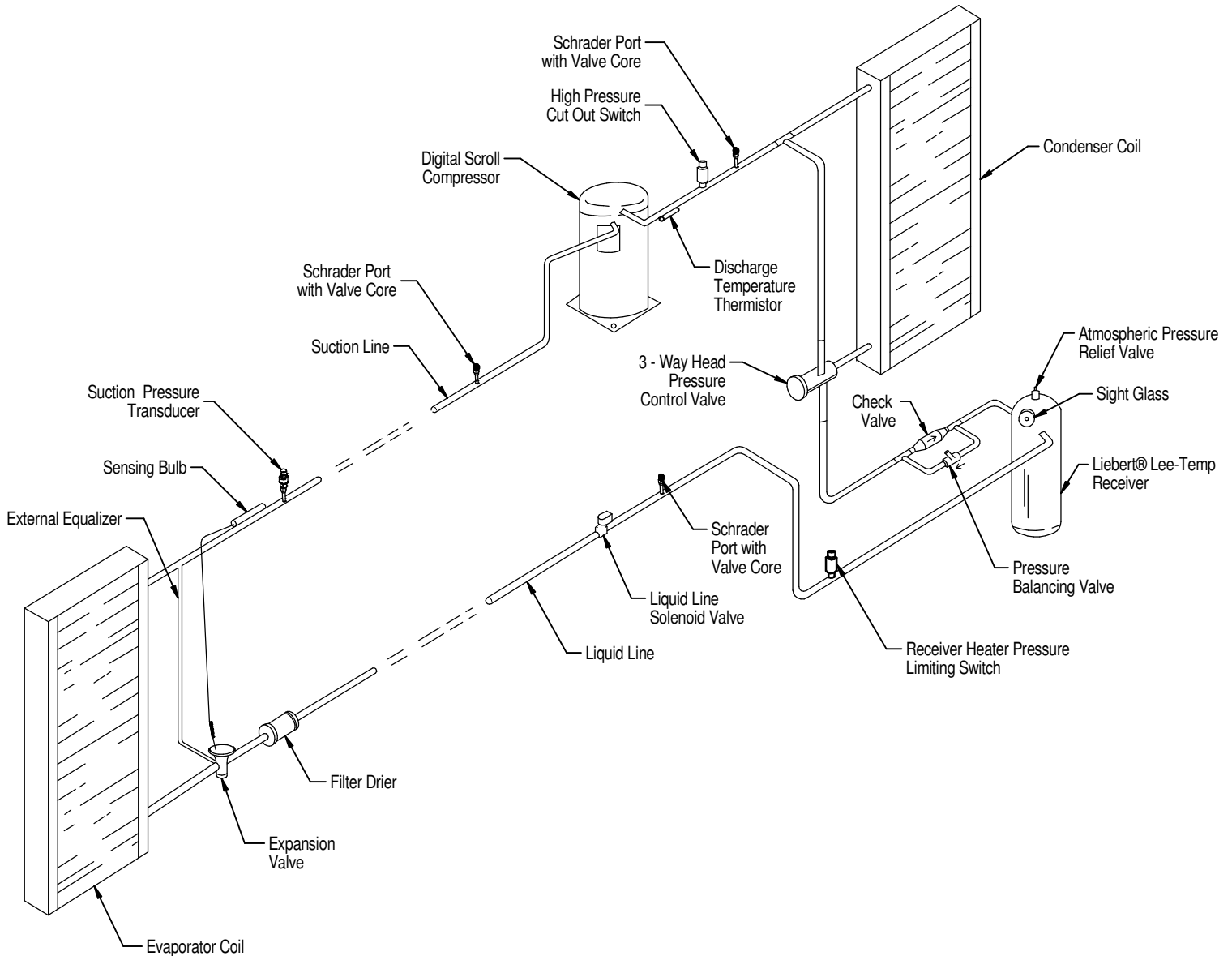

----- FIELD PIPING
 ===== FACTORY PIPING

GENERAL PIPING ARRANGEMENT CONDENSING UNIT

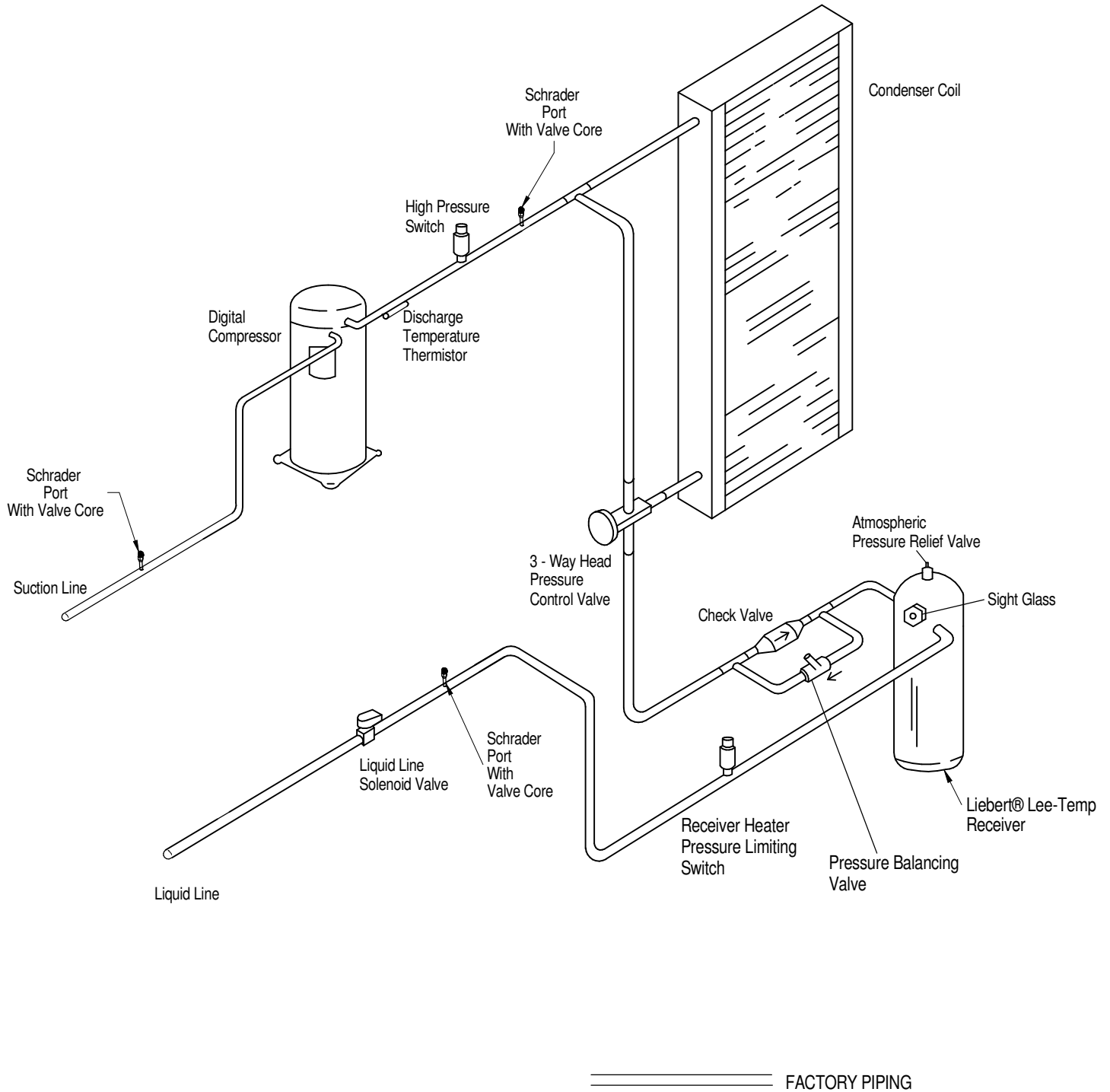

PRIMARY CONNECTION LOCATIONS 5 TON HIGH AMBIENT/QUIET-LINE OUTDOOR CONDENSING UNIT W/ TOP AIR DISCHARGE

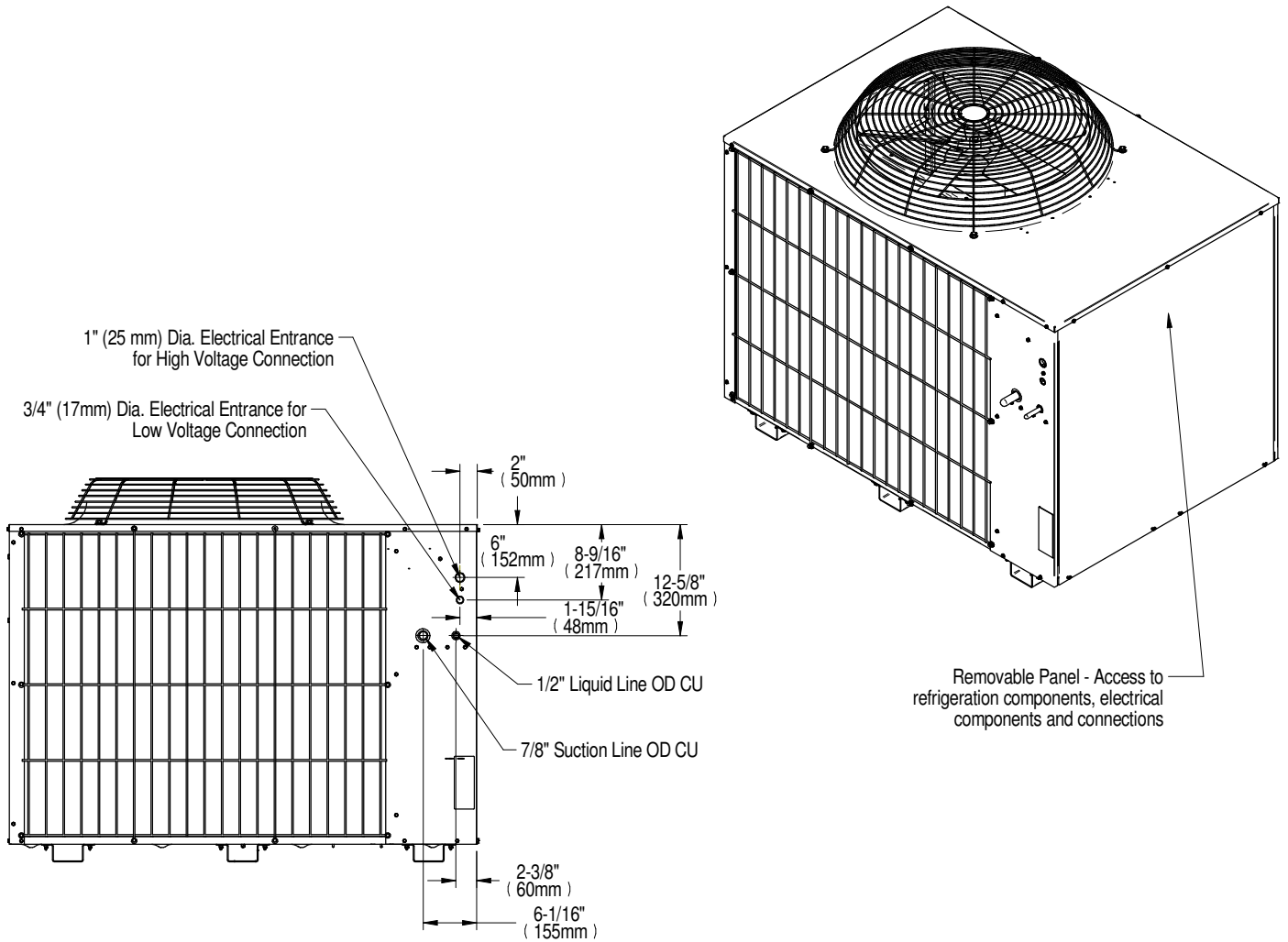

MODEL NUMBERS
60Hz
PFD067A - H
PFDZ67A - L

PRIMARY CONNECTION LOCATIONS CONDENSING UNIT W/ HORIZONTAL AIR DISCHARGE

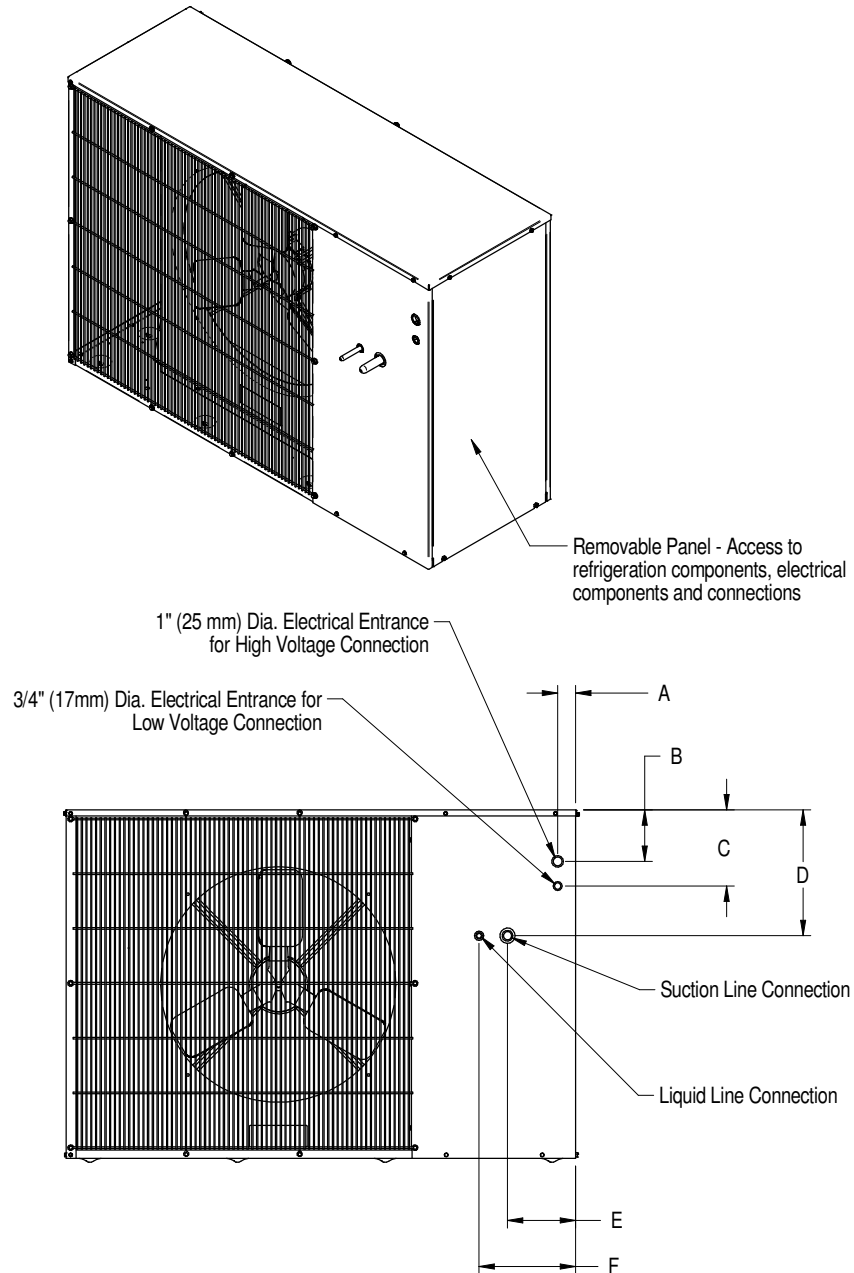

MODEL	ELECTRICAL CONNECTIONS in. (mm)			PIPING CONNECTION LOCATION in. (mm)			PIPING CONNECTION SIZES O.D. CU	
	A	B	C	D	E	F	G	H
PFD037A-L	2 (51)	5-3/4 (146)	8-1/2 (216)	6 (152)	7-1/2 (191)	10-1/2 (267)	3/4"	3/8"
PFD037A-H								
PFD054A-L	2 (51)	5-1/2 (140)	8 (203)	13-1/4 (337)	7-1/4 (184)	10 (254)	7/8"	1/2"
PFD067A-L								

ELECTRICAL FIELD CONNECTIONS
5 TON HIGH AMBIENT/QUIET-LINE OUTDOOR CONDENSING UNIT
W/ TOP AIR DISCHARGE

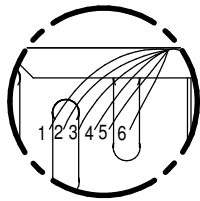
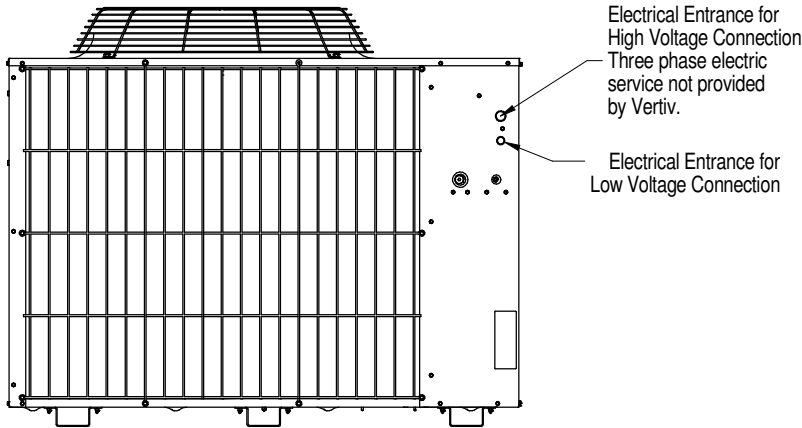

DETAIL A

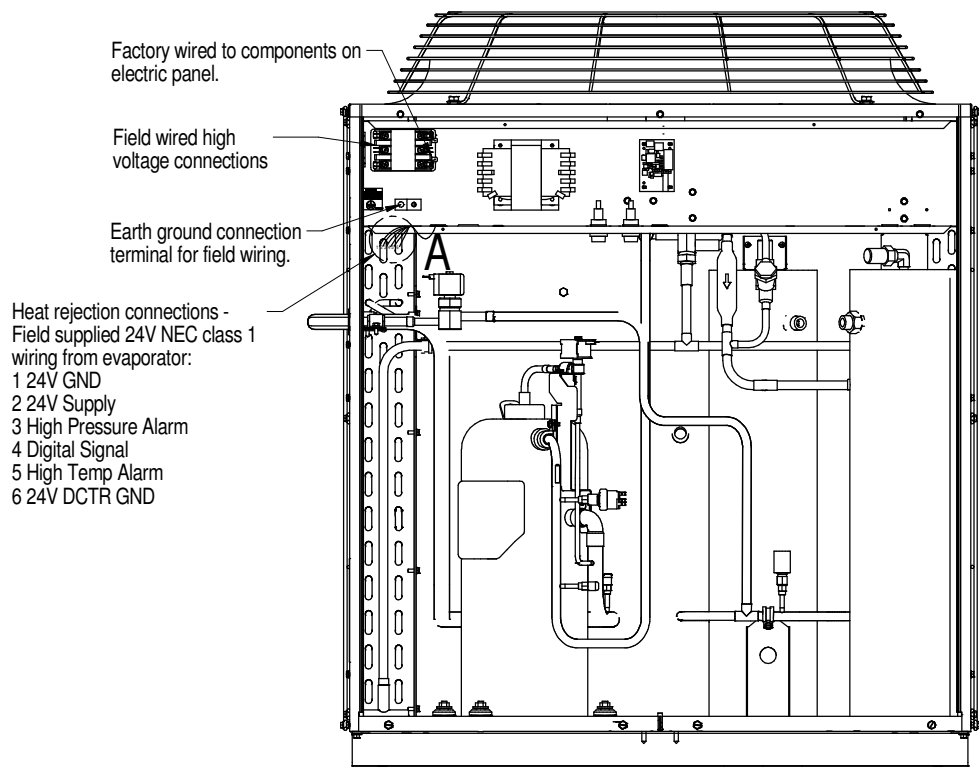

Note:

1. Disconnect Switch to be field supplied, wired, and mounted by others per local and national codes
2. Refer to specification sheet for full load amp and wire size amp ratings.

**ELECTRICAL FIELD CONNECTIONS
CONDENSING UNIT W/ HORIZONTAL AIR DISCHARGE**

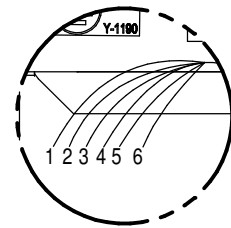
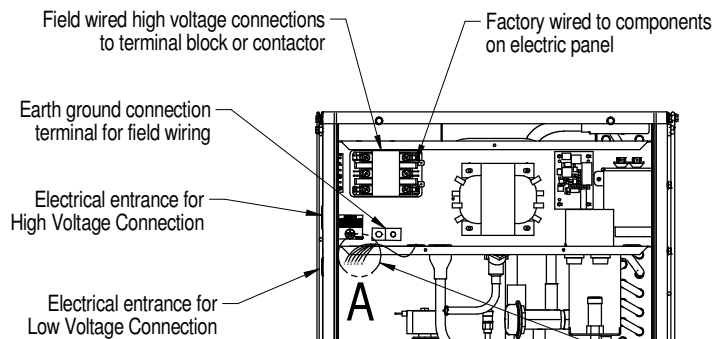
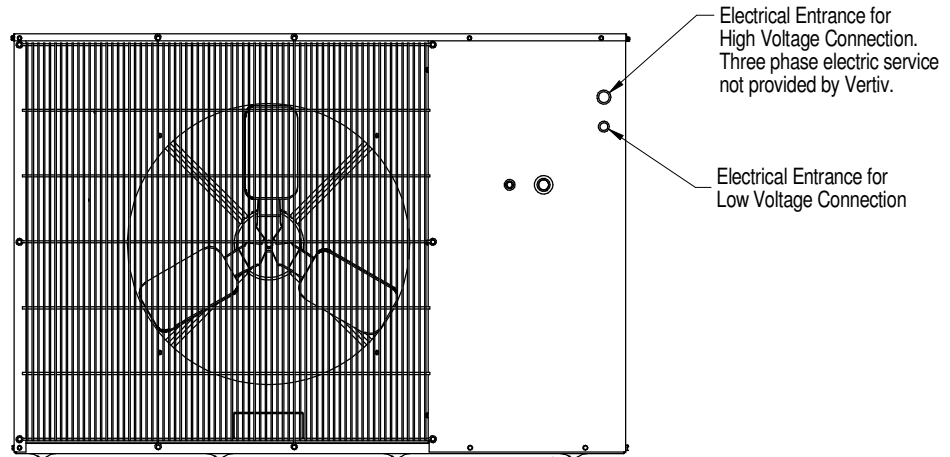

DETAIL A

Heat rejection connection.
Field supplied 24V NEC class 1 wiring.
Wire connections from evaporator module:
1 24V GND
2 24V Supply
3 High Pressure Alarm
4 Digital Signal
5 High Temp Alarm
6 24V DCTR GND

Unit view will vary depending on model size

MODEL NUMBERS
PFD037A-L
PFD037A-H
PFD054A-L
PFD067A-L

Note:

1. Disconnect Switch to be field supplied, wired, and mounted by others per local and national codes.
2. Refer to specification sheet for full load amp and wire size amp ratings.

This page intentionally left blank

Connect with Vertiv on Social Media



<https://www.facebook.com/vertiv/>



<https://www.instagram.com/vertiv/>



<https://www.linkedin.com/company/vertiv/>



<https://www.twitter.com/Vertiv/>



Vertiv.com | Vertiv Headquarters, 505 N Cleveland Ave, Westerville, OH 43082 USA

©2024 Vertiv Group Corp. All rights reserved. Vertiv™ and the Vertiv logo are trademarks or registered trademarks of Vertiv Group Corp. All other names and logos referred to are trade names, trademarks or registered trademarks of their respective owners. While every precaution has been taken to ensure accuracy and completeness here, Vertiv Group Corp. assumes no responsibility, and disclaims all liability, for damages resulting from use of this information or for any errors or omissions.

SL-10550_REV7_07-24