



Liebert[®] Mini-Mate2 Thermal Management System

Installer/User Guide

5-ton Capacity, 50 and 60 Hz

The information contained in this document is subject to change without notice and may not be suitable for all applications. While every precaution has been taken to ensure the accuracy and completeness of this document, Vertiv assumes no responsibility and disclaims all liability for damages resulting from use of this information or for any errors or omissions.

Vertiv recommends installing a monitored fluid detection system that is wired to activate the automatic closure of field-installed coolant fluid supply and return shut off valves, where applicable, to reduce the amount of coolant fluid leakage and consequential equipment and building damage. Refer to local regulations and building codes relating to the application, installation, and operation of this product. The consulting engineer, installer, and/or end user is responsible for compliance with all applicable laws and regulations relating to the application, installation, and operation of this product.

The products covered by this instruction manual are manufactured and/or sold by Vertiv. This document is the property of Vertiv and contains confidential and proprietary information owned by Vertiv. Any copying, use, or disclosure of it without the written permission of Vertiv is strictly prohibited.

Names of companies and products are trademarks or registered trademarks of the respective companies. Any questions regarding usage of trademark names should be directed to the original manufacturer.

Technical Support Site

If you encounter any installation or operational issues with your product, check the pertinent section of this manual to see if the issue can be resolved by following outlined procedures.

Visit <https://www.vertiv.com/en-us/support/> for additional assistance.

TABLE OF CONTENTS

1 Important Safety Instructions	1
1.1 Agency Listed	5
2 Nomenclature	7
2.1 Nomenclature for Evaporator and Chilled Water Units	7
2.2 Nomenclature for Split System Condensing units	9
2.2.1 Indoor Condensing Units for Air Cooled Split Systems	9
2.2.2 Outdoor Prop Fan Condensing Units for Air Cooled Split Systems	10
2.2.3 Water/Glycol Cooled Condensing Units	11
2.3 System Configurations	12
3 Site Preparation and Equipment Handling	15
3.1 Planning Dimensions	15
3.2 Room Preparation	15
3.2.1 Duct Work Considerations for the Indoor Air Cooled Condensing Unit	15
3.3 Application Limits	16
3.4 Location Considerations	16
3.4.1 Location Considerations for Evaporator, Indoor Condensing and Chilled Water Units	17
3.4.2 Location Considerations for an Outdoor Condensing Unit	18
3.5 Indoor Unit Weights	18
3.6 Equipment Inspection and Handling	19
3.7 Packaging Material	19
4 Installation	21
4.1 Installing Ceiling Mounted Evaporators and Condensing Units	21
4.1.1 Installing Suspension Rods and Mounting Ceiling Units	21
4.1.2 Close Coupled Installations for Indoor Condensing Units	23
4.2 Installing Air Distribution Components for Evaporators	23
4.2.1 Installing a Filter Box	24
4.2.2 Guidelines for Ducted Systems	25
5 Piping and Refrigerant Requirements	27
5.1 Fluid Piping Required	28
5.1.1 Drain Line Installation Requirements	28
5.1.2 Condensate Drain Pump Kit	30
5.1.3 Water Supply Line to the Humidifier	31
5.1.4 Chilled Water Loop Piping	31
5.1.5 Water/Glycol Loop Piping	32
5.1.6 Free Cooling Coil Piping	33
5.1.7 Hot Water Reheat Coil Piping	33
5.2 Refrigerant Piping	34
5.2.1 Piping when Condensing Unit is Above or Below Evaporator	35

- 5.2.2 Refrigerant Line Sizes and Equivalent Lengths 36
- 5.2.3 Refrigerant Charge Requirements 37
- 5.2.4 Field Fabricated Refrigeration Piping 38
- 5.2.5 Evacuation and Leak Testing Air Cooled Systems 38
- 5.2.6 Charging Air Cooled Systems 40
- 5.2.7 Field Charge Verification for Air Cooled Systems 41
- 5.2.8 Documenting Refrigerant Charge on Air Cooled Units 41
- 5.2.9 Evacuation and Leak Testing Water/Glycol Cooled Systems 41
- 5.2.10 Charging Water/Glycol Cooled Systems 43
- 5.2.11 Optimizing Refrigerant Charge on Water/Glycol Units 44
- 5.2.12 Documenting Refrigerant Charge on Water/Glycol Cooled Units 44
- 6 Electrical Connection Requirements 45**
- 6.1 Input Power Connection Requirements 46
- 6.2 Control Wiring Connection Requirements 47
 - 6.2.1 Wall Box Controller Control Connections 47
 - 6.2.2 Split System Condensing Unit Control Connections 47
 - 6.2.3 Water/Glycol Cooled Unit Control Connections 47
 - 6.2.4 Additional Control Connections 47
- 7 Checklist for Completed Installation 49**
- 8 Initial Start-up Checks and Commissioning Procedure for Warranty Inspection 51**
- 9 Microprocessor Control 53**
- 9.1 Controller Operation 53
 - 9.1.1 Powering On/Off with Wall Mounted Display 54
 - 9.1.2 Silencing an Audible Alarm 54
- 9.2 Main Menu <MENU> 54
 - 9.2.1 Editing Setpoints 57
 - 9.2.2 Viewing Unit Status 57
 - 9.2.3 Viewing Active Alarms 58
 - 9.2.4 Setting Controller Time 58
 - 9.2.5 Setting Controller Date 58
 - 9.2.6 Programming Setback 58
 - 9.2.7 Editing Setup Operation 59
 - 9.2.8 Changing Setpoint and Setup Passwords 61
 - 9.2.9 Calibrating Sensors and Setting Sensor Response Delay 62
 - 9.2.10 Enabling/Disabling Alarms 63
 - 9.2.11 Setting Alarm Delays 63
 - 9.2.12 Activating the Common Alarm Relay 64
 - 9.2.13 Configuring Custom Alarms 64
 - 9.2.14 Customizing Alarm Message Text 65
 - 9.2.15 LCD Display Contrast 65

9.2.16 Non-volatile Memory	65
9.2.17 Equipment Options DIP Switches	65
9.3 Running Diagnostics	66
9.3.1 Showing Test Inputs	66
9.3.2 Testing Outputs	67
9.3.3 Testing the Microcontroller	68
9.4 System Control and Performance	71
9.4.1 Temperature Control	71
9.4.2 Reheat	71
9.4.3 Humidity Control	73
9.4.4 Load Control	73
9.4.5 Monitoring	73
9.5 Alarm Notification, Acknowledgment, and Descriptions	74
9.5.1 Custom Alarms	74
9.5.2 High Head Pressure Alarm	75
9.5.3 Humidity Level Alarms	75
9.5.4 Temperature Level Alarms	76
9.5.5 Humidifier Problem Alarm	76
9.5.6 High Water Alarm	76
9.5.7 Loss of Power Alarm	76
9.5.8 Short Cycle Alarm	76
9.5.9 Loss of Water Flow Alarm	77
9.5.10 Change Filter Alarm	77
9.5.11 High Temperature Alarm	77
9.5.12 Smoke Alarm	77
10 Maintenance	79
10.1 System Testing	80
10.1.1 Environmental Control Function Tests	80
10.1.2 Cooling Test	80
10.1.3 Heating Test	80
10.1.4 Humidification Test	80
10.1.5 Dehumidification Test	80
10.1.6 Smoke Sensor Test	81
10.1.7 Remote Shutdown Test	81
10.2 Filter Maintenance	81
10.3 Electric Panel Maintenance	81
10.4 Belt Drive Blower Package Maintenance	81
10.4.1 Fan Impeller and Motor Bearing Maintenance	81
10.4.2 Air Distribution Inspection	81
10.4.3 Motor Replacement	81

- 10.4.4 Removing the Blower from the Evaporator 82
- 10.5 Electric Reheat Maintenance 82
- 10.6 Refrigeration System Maintenance 82
 - 10.6.1 Refrigeration Suction Pressure 82
 - 10.6.2 Refrigeration Discharge Pressure 82
 - 10.6.3 Thermostatic Expansion Valve (TXV) Maintenance 83
 - 10.6.4 Air Cooled Condensing Unit Maintenance 83
 - 10.6.5 Hot Gas Bypass Operation and Maintenance 83
 - 10.6.6 Coaxial Condenser Maintenance (Water/Glycol Cooled Condensers Only) 85
 - 10.6.7 Regulating Valve Maintenance (Water/Glycol-cooled Condensers Only) 85
 - 10.6.8 Glycol Solution Maintenance 85
- 10.7 Compressor Maintenance 86
 - 10.7.1 Mechanical Failure of the Compressor 86
 - 10.7.2 Electrical Failure of the Compressor 86
 - 10.7.3 Replacement Compressors 87
 - 10.7.4 Replacing a Failed Compressor 87
- 10.8 Steam Generating Humidifier Maintenance 88
 - 10.8.1 Operating the Humidifier 89
 - 10.8.2 Replacing the Canister 89
 - 10.8.3 Circuit Board Adjustments 91
- 11 Preventive Maintenance Checklist 93**
- 12 Troubleshooting 99**
- Appendices 103**
 - Appendix A: Technical Support and Contacts 103
 - Appendix B: Submittal Drawings 105

1 Important Safety Instructions

SAVE THESE INSTRUCTIONS

This manual contains important safety instructions that should be followed during the installation, and maintenance of the Vertiv™ Liebert® Mini-Mate2. Read this manual thoroughly before attempting to install or operate this unit.

Only qualified personnel should move, install, or service this equipment.

Adhere to all warnings, cautions, notices, and installation, operating, and safety instructions on the unit and in this manual. Follow all installation, operation, and maintenance instructions and all applicable national and local building, electrical, and plumbing codes.



WARNING! Arc flash and electric shock hazard. Open all local and remote electric power supply disconnect switches, verify with a voltmeter that power is Off and wear appropriate, OSHA approved personal protective equipment (PPE) per NFPA 70E before working within the electric control enclosure. Failure to comply can cause serious injury or death. Customer must provide earth ground to unit, per NEC, CEC and local codes, as applicable. Before proceeding with installation, read all instructions, verify that all the parts are included and check the nameplate to be sure the voltage matches available utility power. The Vertiv™ Liebert® iCOM™ controller does not isolate power from the unit, even in the Unit Off mode. Some internal components require and receive power even during the Unit Off mode of the controller. The only way to ensure that there is NO voltage inside the unit is to install and open a remote disconnect switch. Refer to unit electrical schematic. Follow all local codes.



WARNING! Risk of electric shock. Can cause equipment damage, injury, or death. Open all local and remote electric power supply disconnect switches and verify with a voltmeter that power is off before working within any electric connection enclosures. Service and maintenance work must be performed only by properly trained and qualified personnel and in accordance with applicable regulations and manufacturers' specifications. Opening or removing the covers to any equipment may expose personnel to lethal voltages within the unit even when it is apparently not operating and the input wiring is disconnected from the electrical source.



WARNING! Risk of over-pressurization of the refrigeration system. Can cause piping rupture, explosive discharge of high pressure refrigerant, loss of refrigerant, environmental pollution, equipment damage, injury, or death. This unit contains fluids and gases under high pressure. Use extreme caution when charging the refrigerant system. Do not pressurize the system higher than the design pressure marked on the unit's nameplate. Relieve pressure before cutting into or making connections/disconnections to the piping system. Local building or plumbing codes may require installing a pressure relief device in the system.

Consult local building and plumbing codes for installation requirements of additional pressure relief devices when isolation valves are field installed. Do not isolate any refrigerant circuits from over-pressurization protection. The Vertiv™ Liebert® PFH condensing units include a factory installed pressure relief valve mounted on top of the receiver. The valve is rated for a maximum working pressure of 475 psig.



WARNING! Risk of contact with high speed, rotating fan blades. Can cause injury or death. Open all local and remote electric power supply disconnect switches, verify with a voltmeter that power is off, and verify that all fan blades have stopped rotating before working in the unit cabinet.



WARNING! Risk of electric shock. Can cause serious injury or death. The microprocessor does not isolate power from the unit, even in the Unit Off mode. Some internal components require and receive power even during the Unit Off mode of the control. Open all local and remote electric power disconnect switches and verify with a voltmeter that power is Off before working on any component of the system.



WARNING! Risk of improper wiring, piping, moving, lifting, and handling. Can cause equipment damage, serious injury, or death. Installation and service of this equipment should be done only by qualified personnel, wearing appropriate, OSHA approved PPE, who have been specially trained in the installation of air conditioning equipment.



WARNING! Risk of improper wire and loose electrical connections. Can cause overheated wire and electrical connection terminals resulting in smoke, fire, equipment and building damage, injury or death. Use correctly sized copper wire only and verify that all electrical connections are tight before turning power On. Check all electrical connections periodically and tighten as necessary.



WARNING! Risk of ceiling collapse and heavy unit falling. Can cause building and equipment damage, serious injury, or death. Verify that the supporting roof structure is capable of supporting the weight of the unit(s) and the accessories. See [Indoor Unit Weights](#) on page 18 , for the unit weights. Securely anchor the top ends of the suspension rods and verify that all nuts are tight.



WARNING! Risk of smoke and fire. Can cause activation of fire suppression systems, building evacuation, dispatching of fire/rescue equipment and personnel and catastrophic canister failure resulting in water leaks, equipment damage, injury, or death. Using a humidifier canister that has reached the end of it's service life can be extremely hazardous. If the canister cannot be replaced immediately at the end of life condition, turn Off the power and water supply to the humidifier and remove the canister until a replacement canister can be installed. Do not ignore humidifier problem alarms. Resetting humidifier without addressing cause may result in fire or damage due to leaking water.



CAUTION: Risk of excessive refrigerant line pressure. Can cause tubing and component rupture resulting in equipment damage and personal injury. Do not close off any field installed refrigerant line isolation valve for repairs unless a pressure relief valve is field installed in the line between the isolation valve and the check valve. The pressure relief valve must be rated 5% to 10% higher than the system design pressure. An increase in ambient temperature can cause the pressure of the isolated refrigerant to rise and exceed the system design pressure rating (marked on the unit nameplate).



CAUTION: Risk of contact with sharp edges, splinters, and exposed fasteners. Can cause injury. Only properly trained and qualified personnel wearing appropriate, OSHA approved PPE should attempt to move, lift, remove packaging from, or prepare the unit for installation.



CAUTION: Risk of contact with hot surfaces. Can cause injury. The compressor, refrigerant discharge lines, fan motor, and some electrical components are extremely hot during unit operation. Allow sufficient time for them to cool to a touch safe temperature before working within the unit cabinet. Use extreme caution and wear appropriate, OSHA approved PPE when working on or near hot components.



CAUTION: Risk of contact with hot surfaces. Can cause burn injury. The humidifier canister and steam discharge lines are extremely hot during operation. Allow sufficient time for them to cool to a touch safe temperature before handling. Use extreme caution and wear appropriate, OSHA approved PPE when performing maintenance on the humidifier.



CAUTION: Risk of contacting caustic substances. Can cause injury. Avoid touching or contacting the gas and oils with exposed skin. Severe burns will result. Wear appropriate, OSHA approved PPE when handling contaminated parts.

NOTICE

Risk of oil contamination with water. Can cause equipment damage.

Vertiv™ Liebert® Mini-Mate2 DX systems require the use of POE (polyolester) oil. POE oil absorbs water at a much faster rate when exposed to air than previously used oils. Because water is the enemy of a reliable refrigeration system, extreme care must be used when opening systems during installation or service. If water is absorbed into the POE oil, it will not be easily removed and will not be removed through the normal evacuation process. If the oil is too wet, it may require an oil change. POE oils also have a property that makes them act as a solvent in a refrigeration system. Maintaining system cleanliness is extremely important because the oil will tend to bring any foreign matter back to the compressor.

NOTICE

Risk of clogged or leaking drain lines and leaking water supply lines. Can cause equipment and building damage.

This unit requires a water drain connection. Drain lines must be inspected at start-up and periodically, and maintenance must be performed to ensure that drain water runs freely through the drain system and that lines are clear and free of obstructions and in good condition with no visible sign of damage or leaks. This unit may also require an external water supply to operate.

Improper installation, application, and service practices can result in water leakage from the unit. Water leakage can result in catastrophic and expensive building and equipment damage and loss of critical data center equipment.

Do not locate unit directly above any equipment that could sustain water damage.

We recommend installing a monitored fluid detection system to immediately discover and report coolant fluid system and condensate drain line leaks.

NOTICE

Risk of leaking water/glycol. Can cause equipment and building damage.

Improper installation, application, and service practices can result in water leakage from the unit. Do not mount this unit over equipment and furniture that can be damaged by leaking water. Install a water tight drain pan with a drain connection under the cooling unit and the ceiling mounted water/glycol condensing unit. Route the drain line to a frequently used maintenance sink so that running water can be observed and reported in a timely manner. Post a sign to alert people to report water flowing from the secondary drain pan. We recommend installing monitored leak detection equipment for the unit and supply lines and in the secondary drain pan. Check drain lines periodically for leaks, sediment buildup, obstructions, kinks and/or damage and verify that they are free running.

NOTICE

Risk of piping system corrosion and freezing fluids. Can cause leaks resulting in equipment and very expensive building damage. Cooling coils and piping systems are at high risk of freezing and premature corrosion. Fluids in these systems must contain the proper antifreeze and inhibitors to prevent freezing and premature coil and piping corrosion. The water or water/glycol solution must be analyzed by a competent local water treatment specialist before start up to establish the inhibitor and antifreeze solution requirement and at regularly scheduled intervals throughout the life of the system to determine the pattern of inhibitor depletion.

The complexity of water/glycol solution condition problems and the variations of required treatment programs make it extremely important to obtain the advice of a competent and experienced water treatment specialist and follow a regularly scheduled coolant fluid system maintenance program.

Water chemistry varies greatly by location, as do the required additives, called inhibitors, that reduce the corrosive effect of the fluids on the piping systems and components. The chemistry of the water used must be considered, because water from some sources may contain corrosive elements that reduce the effectiveness of the inhibited formulation. Sediment deposits prevent the formation of a protective oxide layer on the inside of the coolant system components and piping. The water/coolant fluid must be treated and circulating through the system continuously to prevent the buildup of sediment deposits and or growth of sulfate reducing bacteria.

Proper inhibitor maintenance must be performed in order to prevent corrosion of the system. Consult glycol manufacturer for testing and maintenance of inhibitors.

Commercial ethylene glycol, when pure, is generally less corrosive to the common metals of construction than water itself. It will, however, assume the corrosivity of the water from which it is prepared and may become increasingly corrosive with use if not properly inhibited.

We recommend installing a monitored fluid detection system that is wired to activate the automatic closure of field installed coolant fluid supply and return shut-off valves to reduce the amount of coolant fluid leakage and consequential equipment and building damage. The shut-off valves must be sized to close off against the maximum coolant fluid system pressure in case of a catastrophic fluid leak.

NOTICE

Risk of frozen pipes and corrosion from improper coolant mixture. Can cause water leaks resulting in equipment and building damage.

When piping or the cooling unit may be exposed to freezing temperatures, charge the system with the proper percentage of glycol and water for the coldest design ambient temperature. Automotive antifreeze is unacceptable and must NOT be used in any glycol fluid system. Use only HVAC glycol solution that meets the requirements of recommended industry practices.

NOTICE

Risk of no flow condition. Can cause equipment damage. Do not leave the water/coolant fluid supply circuit in a no flow condition. Idle fluid allows the collection of sediment that prevents the formation of a protective oxide layer on the inside of tubes. Keep unit switched On and water/coolant fluid supply circuit system operating continuously.

NOTICE

Risk of improper water supply. Can reduce humidifier efficiency or obstruct humidifier plumbing.

Do not use completely demineralized water with this unit. The water must contain minerals for the electrode principle to work.

Do not use a hot water source. It will cause deposits that will eventually block the fill valve opening.

NOTICE

Risk of water backing up in the drain line. Leaking and overflowing water can cause equipment and building damage.

Do not install an external trap in the drain line. This line already has a factory installed trap inside the cabinet. Installation of a second trap will prevent drain water flow and will cause the water to overflow the drain pan.

This line may contain boiling water. Use copper or other material that is rated for handling boiling water for the drain line. Sagging condensate drain lines may inadvertently create an external trap.

NOTICE

Risk of doorway/hallway interference. Can cause unit and/or structure damage. The unit may be too large to fit through a doorway or hallway while on the skid. Measure the unit and passageway dimensions, and refer to the installation plans prior to moving the unit to verify clearances.

NOTICE

Risk of damage from forklift. Can cause unit damage. Keep tines of the forklift level and at a height suitable to fit below the skid and/or unit to prevent exterior and/or underside damage.

NOTICE

Risk of improper storage. Can cause unit damage.

Keep the unit upright, indoors, and protected from dampness, freezing temperatures, and contact damage.

1.1 Agency Listed

Standard 60-Hz units are CSA Certified to the harmonized U.S. and Canadian product safety standard CSA C22.2 No 236/UL 1995 for "Heating and Cooling Equipment" and are marked with the CSA c-us logo.



This page intentionally left blank

2 Nomenclature

This section describes the model number configuration for Vertiv™ Liebert® Mini-Mate2 units and components.

2.1 Nomenclature for Evaporator and Chilled Water Units

Table 2.2 on the next page describes each digit of the model number.

Table 2.1 Nomenclature Example

1	2	3	4	5	6	7	8	9	10	11	12
M	M	D	6	0	E	N	C	R	E	L	5

Table 2.2 Nomenclature Digit Definitions for Evaporator and Chilled Water Units

Digit	Description
Digits 1 and 2 = the base unit MM = Mini-Mate2	
Digit 3 = Disconnect D = Disconnect switch	
Digit 4 and 5 = Nominal Capacity 60 = 60 kBtuh, 60 Hz evaporator 59 = 59 kBtuh, 50 Hz evaporator 91 = 91 kBtuh, 50 Hz chilled water 92 = 92 kBtuh, 60 Hz chilled water	
Digit 6 = Cooling type C = Chilled water cooled E = Split system evaporator (See Nomenclature for Split System Condensing units on page 9.) K = Split system evaporator with free cooling (See Nomenclature for Split System Condensing units on page 9.)	
Digit 7 = Refrigerant/Valve type N = R-407C field charged, DX evaporator 2 = 2-way standard-pressure chilled water valve 3 = 3-way standard-pressure chilled water valve D = 2-way high-pressure chilled water valve T = 3-way high-pressure chilled water valve	
Digit 8 = Supply power A = 460 V / 3 ph / 60 Hz B = 575 V / 3 ph / 60 Hz C = 208 V / 3 ph / 60 Hz D = 230 V / 3 ph / 60 Hz M = 380/415 V / 3 ph / 50 Hz	

Table 2.2 Nomenclature Digit Definitions for Evaporator and Chilled Water Units (continued)

Digit	Description
Digit 9 = Humidification	R = Remote Humidifier Contact (without canister humidifier) J = Canister Humidifier and Remote Humidifier Contact
Digit 10 = Reheat	0 = No reheat E = Electric reheat S = SCR reheat (for DX evaporator without free cooling option) H = Hot water reheat (chilled water systems only)
Digit 11 = Blower type	L = Low static blower, 1.5-hp motor H = High static blower, 2-hp motor
Digit 12 = Sensor packages	N = Base package of filter clog and high temperature sensor 2 = Smoke sensor + Base package 4 = IS-UNITY-DP (BMS) + Base Package 5 = IS-UNITY-DP (BMS) + Smoke sensor + Base package

2.2 Nomenclature for Split System Condensing units

This section describes the model number configuration for Vertiv™ Liebert® Mini-Mate2 split system condensing units.

2.2.1 Indoor Condensing Units for Air Cooled Split Systems

Table 2.4 below describes each digit of the model number.

Table 2.3 Indoor, Air Cooled Condensing Unit Nomenclature Example

1	2	3	4	5	6	7	8	9	10
M	C	D	6	5	A	L	A	H	N

Table 2.4 Nomenclature Digit Definitions for Indoor, Air Cooled Condensing Units

Digit	Description
Digits 1 to 2 = the base unit	MC = Liebert® Mini-Mate2 condensing unit
Digit 3 = Disconnect	D = Disconnect switch
Digit 4 and 5 = Nominal Capacity	65 = 65 kBtuh, 60 Hz 64 = 64 kBtuh, 50 Hz
Digit 6 = Cooling type	A = Air cooled
Digit 7 = Head pressure control	L = Liebert® Lee-Temp Receiver
Digit 8 = Supply power	A = 460 V / 3 ph / 60 Hz B = 575 V / 3 ph / 60 Hz M = 380/415 V / 3 ph / 50 Hz Y = 208/230 V / 3 ph / 60 Hz
Digit 9 = Hot gas bypass	H = Hot-gas bypass
Digit 10 = Refrigerant	N = R-407C field charged

2.2.2 Outdoor Prop Fan Condensing Units for Air Cooled Split Systems

Table 2.6 below describes each digit of the model number.

Table 2.5 Prop Fan Condensing Unit Nomenclature Example

1	2	3	4	5	6	7	8	9	10	11
P	F	H	0	6	7	A	—	A	L	N

Table 2.6 Nomenclature Digit Definitions for Outdoor, Prop Fan Condensing Units

Digit	Description
Digits 1 to 3 = the base unit	PFH = Prop fan condensing unit with hot gas bypass
Digit 4 = Sound level	0 = Standard Z = Quiet-Line
Digit 5 and 6 = Nominal Capacity	66 = 66 kBtuh, 50 Hz 67 = 67 kBtuh, 60 Hz
Digit 7 = Cooling type	A = Air cooled
Digit 8 = Coil type	— = Standard coil C = Coated coil (epoxy with UV topcoat)
Digit 9 = Supply power	A = 460 V / 3 ph / 60 Hz B = 575 V / 3 ph / 60 Hz M = 380/415 V / 3 ph / 50 Hz Y = 208/230 V / 3 ph / 60 Hz
Digit 10 = Ambient rating/Control	L = 95°F Ambient, Liebert® Lee-Temp H = 105°F Ambient, Liebert® Lee-Temp
Digit 11 = Refrigerant	N = R-407C field charged

2.2.3 Water/Glycol Cooled Condensing Units

Table 2.8 below describes each digit of the model number.

Table 2.7 Remote, Indoor Water/Glycol Condensing Unit Nomenclature Example

1	2	3	4	5	6	7	8	9	10
M	C	D	6	9	W	2	A	H	N

Table 2.8 Nomenclature Digit Definitions for Indoor, Water/Glycol Cooled Condensing Units

Digit	Description
Digits 1 to 2 = the base unit	MC = Liebert® Mini-Mate2 condensing unit
Digit 3 = Disconnect	D = Disconnect switch
Digit 4 and 5 = Nominal Capacity	69 = 69 kBtuh, 60 Hz 68 = 68 kBtuh, 50 Hz
Digit 6 = Cooling type	W = Water/Glycol-cooled
Digit 7 = Head pressure control	2 = 2-way standard-pressure fluid regulating valve 3 = 3-way standard-pressure fluid regulating valve D = 2-way high-pressure fluid regulating valve T = 3-way high-pressure fluid regulating valve
Digit 8 = Supply power	A = 460 V / 3 ph / 60 Hz B = 575 V / 3 ph / 60 Hz M = 380/415 V / 3 ph / 50 Hz Y = 208/230 V / 3 ph / 60 Hz
Digit 9 = Hot gas bypass	H = Hot gas bypass
Digit 10 = Refrigerant	N = R-407C field charged

2.3 System Configurations

The following figures show the available capacity and cooling options for the Vertiv™ Liebert® Mini-Mate2.

Figure 2.1 Air Cooled Units

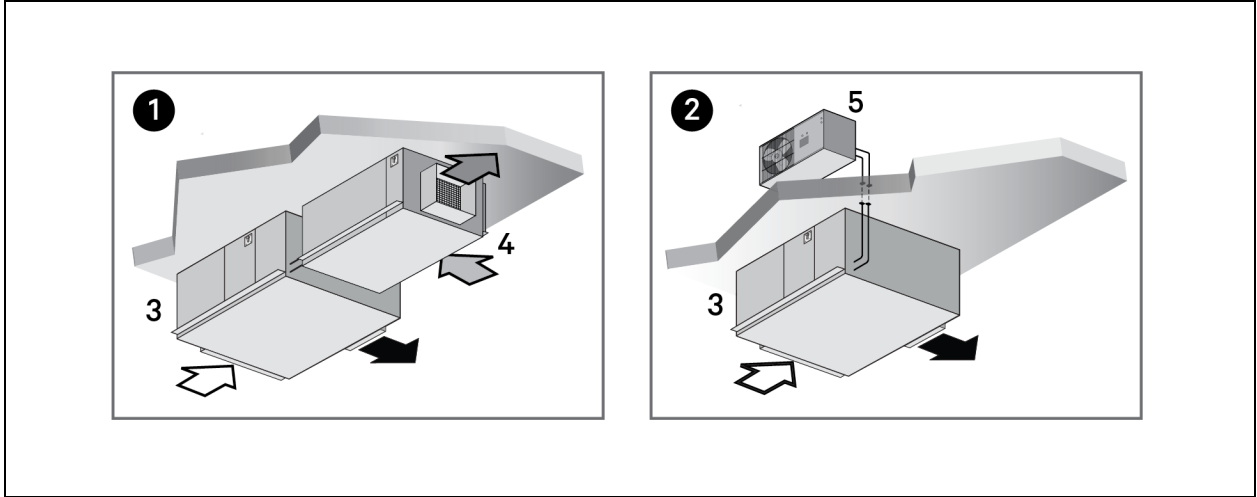

Item	Description
1	Split system (indoor condensing unit) with ducted supply/return air
2	Split system (outdoor condensing unit) with ducted supply/return air
3	Evaporator
4	Indoor condensing unit
5	Outdoor condensing unit

Figure 2.2 Water/Glycol Cooled Units

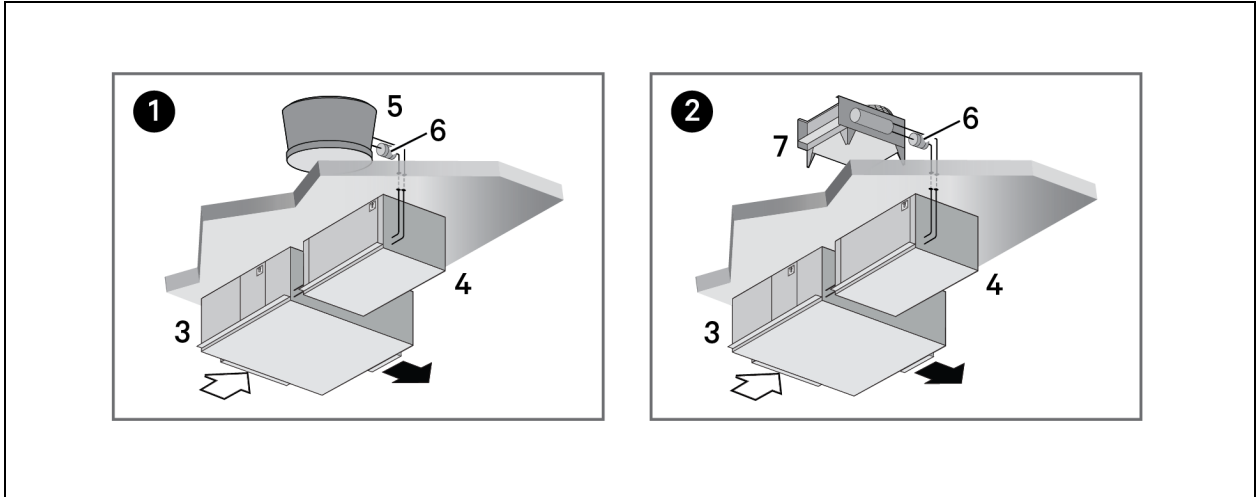

Item	Description
1	Split system water cooled with ducted supply/return air
2	Split system glycol cooled with ducted supply/return air
3	Evaporator
4	Water/Glycol condensing unit
5	Cooling tower
6	Pump
7	Drycooler

Figure 2.3 Chilled Water Units

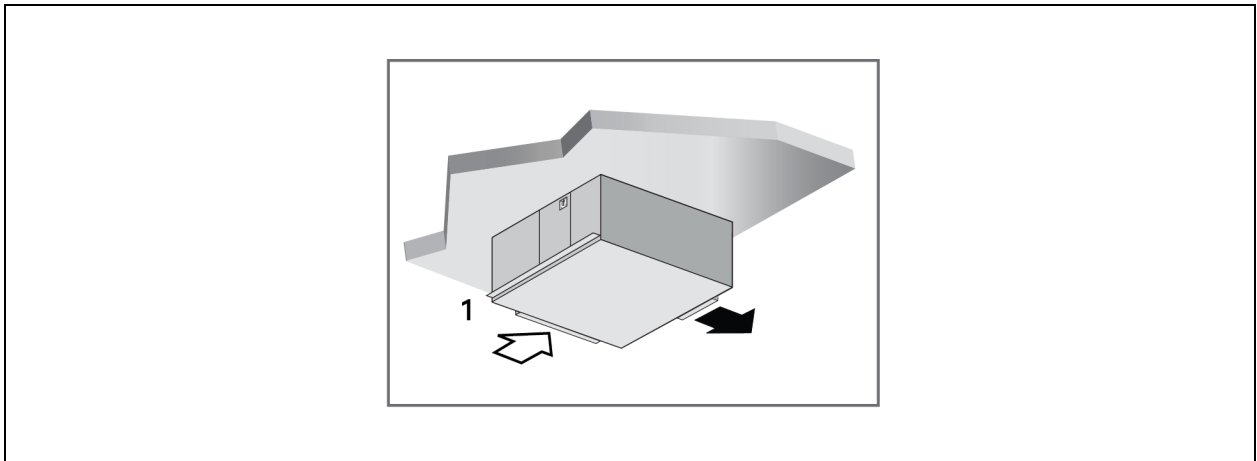

Item	Description
1	Chilled water unit with ducted supply/return air

This page intentionally left blank

3 Site Preparation and Equipment Handling

NOTE: Before installing unit, determine whether any building alterations are required to run piping, wiring, and ductwork. Follow all unit dimensional drawings and refer to the submittal engineering dimensional drawings of individual units for proper clearances.

3.1 Planning Dimensions

The unit dimensions are described in the submittal documents included in the [Submittal Drawings](#) on page 105.

The following table lists the relevant documents by number and title.

Table 3.1 Dimension Planning Drawings

Document Number	Title
Split System Evaporators/Chilled Water Units	
DPN000218	Evaporator/Chilled Water Unit and Filter Box Option Dimensions
Indoor Condensing Units	
DPN004422	Cabinet Dimensions, Air Cooled Units
DPN004423	Cabinet Dimensions, Water/Glycol Cooled Units

3.2 Room Preparation

The room should be well insulated and must have a sealed vapor barrier. The vapor barrier in the ceiling and walls can be a polyethylene film. Paint on concrete walls and floors should be vapor resistant.

NOTE: The vapor barrier is the single most important requirement for maintaining environmental control in the conditioned area.

Outside or fresh air should be kept to a minimum when tight temperature and humidity control is required. Outside air adds to the site's cooling, heating, dehumidifying, and humidifying loads. Doors should be properly sealed to minimize leaks and should not contain ventilation grilles.

NOTE: Temperature and humidity sensors are located in the wall box. Proper and efficient cooling requires placing the wall box where discharge air does not directly blow on the sensors.

3.2.1 Duct Work Considerations for the Indoor Air Cooled Condensing Unit

Observe the following when planning the installation of the indoor air cooled condensing unit:

Ensure a satisfactory source of clean air for the condensing unit supply and a means to discharge the hot air without allowing the supply and discharge air to mix. Consider duct work to outdoor air. Duct work for outdoor air to and from the condensing unit is optional.

The total external static pressure for the inlet and outlet ducts, including grille, must not exceed 0.5 inch of water. Hood intake and duct work cross-sectional area dimensions should be equal to or greater than the area of the condensing unit intake flange.

For all duct work installation, see [Guidelines for Ducted Systems](#) on page 25.

3.3 Application Limits

Table 3.2 Application Limits for Evaporator and Chilled Water Units

Input Voltage		Range of Return Air Conditions to the Unit*	
Minimum	Maximum	Dry Bulb Temperature	Relative Humidity
-5%	+10%	65 to 85°F (18 to 29°C)	20 to 80%

*The unit will operate at these conditions, but it will not control to these condition extremes.

Table 3.3 Application Limits for Indoor and Outdoor Air Cooled Condensing Unit

Input Voltage		Condensing Unit Type	Entering Dry Bulb Air Temperature	
Minimum	Maximum		Minimum	Maximum
-5%	+10%	Outdoor Prop fan condensing unit	-30°F (-34°C)	120°F (49°C)
-5%	+10%	Indoor air cooled condensing unit	-20°F (-29°C)	115°F (46°C)

Table 3.4 Application Limits for Indoor Water/Glycol Cooled Condensing Unit

Input Voltage		Entering Fluid Temperature	
Minimum	Maximum	Minimum	Maximum
-5%	+10%	65°F (18°C)*	115°F (46°C)

*Operation below 65°F (18°C) may result in fluid noise and reduced valve life.

3.4 Location Considerations

When determining installation locations, consider that these units contain water and that water leaks can cause damage to sensitive equipment and furniture below.

NOTICE

Risk of leaking water/glycol. Can cause equipment and building damage.

Improper installation, application, and service practices can result in water leakage from the unit. Do not mount this unit over equipment and furniture that can be damaged by leaking water. Install a water tight drain pan with a drain connection under the cooling unit and the ceiling mounted water/glycol condensing unit. Route the drain line to a frequently used maintenance sink so that running water can be observed and reported in a timely manner. Post a sign to alert people to report water flowing from the secondary drain pan. We recommend installing monitored leak detection equipment for the unit and supply lines and in the secondary drain pan. Check drain lines periodically for leaks, sediment buildup, obstructions, kinks and/or damage and verify that they are free running.

3.4.1 Location Considerations for Evaporator, Indoor Condensing and Chilled Water Units

The evaporator or chilled water unit is usually mounted above the suspended ceiling and must be securely mounted to the roof structure. For ducted systems, the evaporator may be located in a different room from the heat producing equipment.

For a split system with an indoor condensing unit, the condensing unit may be:

- Installed above the suspended ceiling near the evaporator or closely coupled with the evaporator.
- In any remote indoor area, subject to the requirements detailed in [Piping when Condensing Unit is Above or Below Evaporator](#) on page 35 .

Refer to [Refrigerant Line Sizes and Equivalent Lengths](#) on page 36 for maximum refrigerant line lengths.

The ceiling and ceiling supports of existing buildings may require reinforcement. Be sure to follow all applicable national and local codes.

Install the ceiling mounting over an unobstructed floor space, if possible. This will allow easy access for routine maintenance or service. Do not attach additional devices (such as smoke detectors, etc.) to the housing, as they could interfere with the maintenance or service.

NOTE: Temperature and humidity sensors are in the wall box. Install the wall box where discharge air DOES NOT blow directly on the sensors.

Do not install units in areas where normal unit operating sound may disturb the working environment.

When installing an air cooled or water/glycol cooled unit inside a space, ensure that national and local codes are met for refrigerant concentration limits that might vary with building type and use.

3.4.2 Location Considerations for an Outdoor Condensing Unit

For a split system with an air cooled, outdoor condensing unit, the condensing unit may be mounted on the roof or remotely in any outdoor area.

Observe the following when planning the installation of the outdoor unit:

- To ensure a satisfactory air supply, locate air cooled condensing units in an environment with clear air, away from loose dirt and foreign matter that may clog the coil.
- Condensing units must not be located in the vicinity of steam, hot air or fume exhausts or closer than 18 inches from a wall, obstruction or adjacent unit.
- Avoid areas where heavy snow will accumulate at air inlet and discharge locations.
- The condensing unit should be located for maximum security and maintenance accessibility. Avoid ground level sites with public access. Install a solid base, capable of supporting the weight of the condensing unit.
- The base should be at least 2 inches (51 mm) higher than the surrounding grade and 2 inches (51 mm) larger than the dimensions of the condensing unit base. For snowy areas, a base of sufficient height to clear snow accumulation must be installed.
- Securely attach the unit to the base using the holes provided in the unit mounting rails to prevent unit movement that might stress refrigerant piping and electrical wiring.

Before beginning, refer to [Piping and Refrigerant Requirements](#) on page 27 for unit placement, piping guidelines, and refrigerant charge requirements for your system.

The condensing unit must be located within the maximum distance from evaporator guidelines listed in **Table 5.6** on page 35.

3.5 Indoor Unit Weights

Table 3.5 Indoor Unit Weights

Model #	Weight, lb (kg)
Cooling Units*	
MMD60E	498 (226)
MMD59E	498 (226)
MMD92C	498 (226)
MMD91C	498 (226)
Condensing Units	
MCD65A	449 (204)
MCD64A	449 (204)
MCD69W	282 (128)
MCD68W	282 (128)
*Add 32 lb. (14 kg.) to units with free cooling or hot water reheat coils.	

3.6 Equipment Inspection and Handling



CAUTION: Risk of contact with sharp edges, splinters, and exposed fasteners. Can cause injury. Only properly trained and qualified personnel wearing appropriate, OSHA approved PPE should attempt to move, lift, remove packaging from, or prepare the unit for installation.

Do not un-crate the equipment until it is close to its final location. All required assemblies are banded and shipped in corrugated containers. If any damage is discovered when the unit is un-crated, report it to the shipper immediately. If any concealed damage is later discovered, report it to the shipper and to your Vertiv representative.

3.7 Packaging Material

All material used to package this unit is recyclable. Save it for future use or dispose of the material appropriately.

This page intentionally left blank

4 Installation

Refer to the appropriate installation procedures depending the configuration and options of your Vertiv™ Liebert® Mini-Mate2 Thermal Management System.

4.1 Installing Ceiling Mounted Evaporators and Condensing Units



WARNING! Risk of ceiling collapse and heavy unit falling. Can cause building and equipment damage, serious injury, or death. Verify that the supporting roof structure is capable of supporting the weight of the unit(s) and the accessories. See [Indoor Unit Weights](#) on page 18 , for the unit weights. Securely anchor the top ends of the suspension rods and verify that all nuts are tight.

NOTICE

Risk of leaking water/glycol. Can cause equipment and building damage.

Improper installation, application, and service practices can result in water leakage from the unit. Do not mount this unit over equipment and furniture that can be damaged by leaking water. Install a water tight drain pan with a drain connection under the cooling unit and the ceiling mounted water/glycol condensing unit. Route the drain line to a frequently used maintenance sink so that running water can be observed and reported in a timely manner. Post a sign to alert people to report water flowing from the secondary drain pan. We recommend installing monitored leak detection equipment for the unit and supply lines and in the secondary drain pan. Check drain lines periodically for leaks, sediment buildup, obstructions, kinks and/or damage and verify that they are free running.

4.1.1 Installing Suspension Rods and Mounting Ceiling Units

Refer to the [Location Considerations](#) on page 16 before beginning installation. These instructions apply to evaporators, indoor air cooled condensing units, and indoor water/glycol cooled condensing units.

NOTE: Follow all national and local building, electrical, and plumbing codes.

- The ceiling and ceiling supports of existing buildings may require reinforcements.
- Four 3/8-inch 16 TPI threaded suspension rods are required and field supplied.
- The factory supplied 3/8-inch 16 TPI hardware kit includes the remaining installation hardware.
- Recommended clearance between ceiling grids and building structural members is the unit's height plus 3 inches (76 mm).

To install the suspension rods:

1. Install the four field supplied 3/8-inch 16 TPI threaded rods by suspending them from suitable building structural members so that they will align with the four mounting locations on the unit base.
2. Securely anchor the top ends of the suspension rods with field supplied nuts.
3. Make sure all nuts are tight and locked.

To lift and install the unit on the rods:

1. Using a suitable lifting device that is rated for the weight of the unit (see [Indoor Unit Weights](#) on page 18), raise the unit and pass the threaded rods through the four mounting locations in the unit base.
2. Attach the threaded rods to the flanges using the plain nuts to hold the unit in place as shown in **Figure 4.1** below .
3. Slowly lower the lifting device, making sure that the rods securely hold the weight of the unit.
4. Adjust the plain nuts to distribute the weight of the unit evenly by the rods, making sure that the unit does not rest on the ceiling grid and that the unit is level.

NOTE: Evaporator units must be level to properly drain condensate. This does not apply to condensing units.

5. Use the Nylock nuts to jam the plain nuts in place as shown in **Figure 4.1** below .

Figure 4.1 Installing Threaded Rods and Hardware of Ceiling Mounted Units

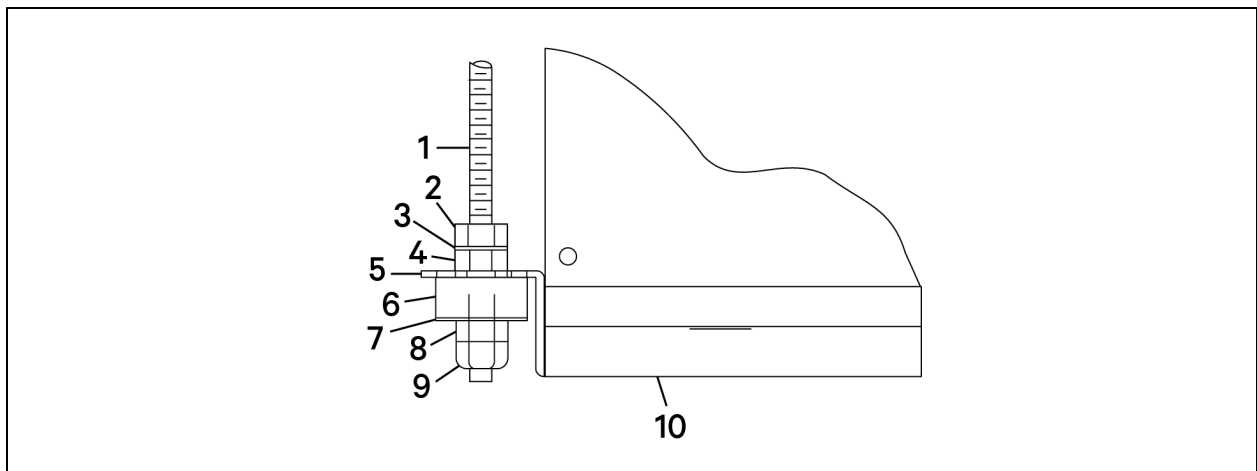

Item	Description	Item	Description
1	3/8-in. threaded rod, field supplied	7	3/8-in. fender washer
2	3/8-in. hex nut	8	3/8-in. hex nut
3	3/8-in. washer	9	3/8-in. Nylock locking nut
4	Sleeve	10	Unit base pan (reference)
5	Bracket on unit		
6	Isolator		

4.1.2 Close Coupled Installations for Indoor Condensing Units

You can mount the evaporator and indoor condensing units directly next to each other, close coupled.

Close coupled installations may take advantage of a single point power kit to allow one power feed to provide input for both evaporator and condensing units.

To install close coupled indoor units:

- If you are using a single point power kit:
 - Install the single point power box into the condensing unit before assembling the condensing unit to the evaporator and before raising the unit to the ceiling.
 - Route power wire flex conduit into condensing unit when raising units to ceiling.
 - Refer to the instructions supplied with kit for details
- Raise the units to the ceiling before connecting them. See [Installing Suspension Rods and Mounting Ceiling Units](#) on page 21.
- Align the four bolt holes in the condensing unit with cage nuts provided on the evaporator.
- Insert rubber spacers and secure with hardware (field provided).
- Align the refrigerant connections as shown in **Figure 4.2** below.
- Braze the refrigerant connections together as detailed in [Refrigerant Piping](#) on page 34.

Figure 4.2 Evaporator/Condensing Unit Close Coupling Connections

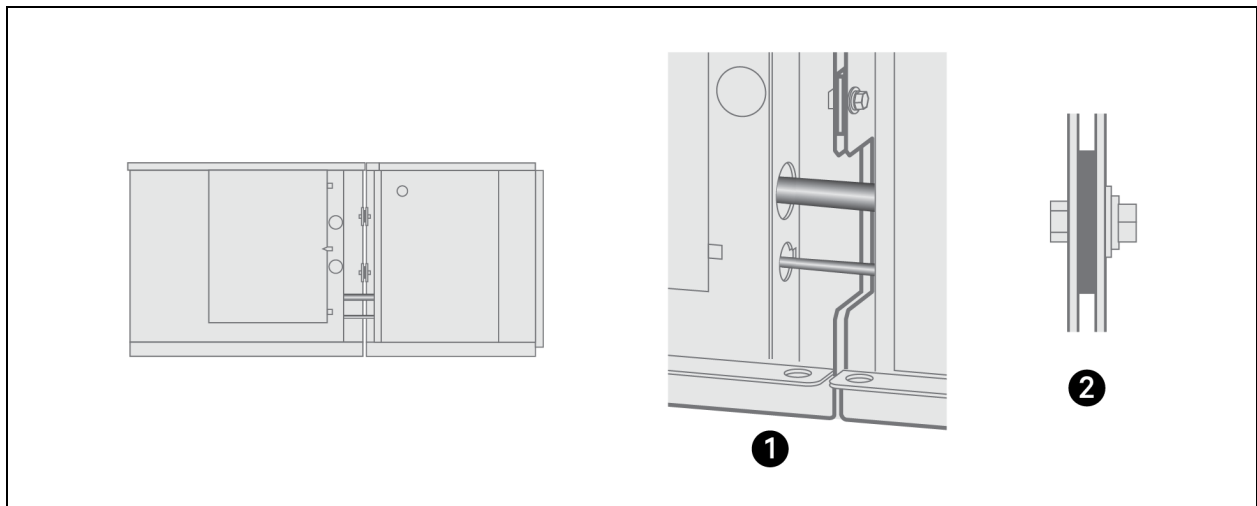

Item	Description
1	Close coupled connections
2	Spacer between evaporator and condensing unit in close coupled installations

4.2 Installing Air Distribution Components for Evaporators

Your indoor units may include a filter box and ducting. Refer to the appropriate installation procedures for each.

4.2.1 Installing a Filter Box

The optional filter box attaches directly to the return air opening of the evaporator.

The following is included:

- For the return air opening, the filter box includes a 1-inch (25.4-mm) duct flange connection with two MERV 8 filters (per ASHRAE 52.2-2007), 20 inches x 20 inches x 4 inches (508 mm x 508 mm x 102 mm).
- For the supply air opening, a 1-inch (25.4 mm) duct flange is included.

NOTE: Do not operate the unit without filters installed in return air system.

4.2.2 Guidelines for Ducted Systems

Observe the following for all duct work:

- Duct work should be fabricated and installed in accordance with local and national codes
- Use flexible duct work or nonflammable cloth collars to attach duct work to the unit and to control vibration transmission to the building.
- Attach the duct work to the unit using the flanges provided.
- Locate the unit and duct work so that the discharge air does not short circuit to the return air inlet.
- Duct work that runs through a conditioned space or is exposed to areas where condensation may occur must be insulated. Insulation of duct work is vital to prevent condensation during the cooling cycle.
- The use of a vapor barrier is required to prevent absorption of moisture from the surrounding air into the insulation.
- If the return air duct is short or if noise is likely to be a problem, sound absorbing insulation should be used inside the duct.
- Duct work should be suspended using flexible hangers. Duct work should not be fastened directly to the building structure.
- For multiple unit installations, space the units so that the hot condensing unit exhaust air is not directed toward the air inlet of an adjacent unit.

Consider the following in specific applications of duct work to evaporator or chilled water units:

- The evaporator unit is designed for 2500 CFM. Use **Table 4.1** below, to adjust the blower speed for ESP created by duct work to maintain 2500 CFM (4248 CMH).

Table 4.1 Evaporator External Static Pressure

Turns Open	1.5 hp Motor (60 Hz)		2.0 hp Motor (60 Hz)	
	Blower rpm	External Static, in.	Blower rpm	External Static, in.
1	N/A	N/A	1329	N/A
1.5	N/A	N/A	1296	N/A
2	1037	0.9	1264	N/A
2.5	1005	0.7	1231	1.5
3	972	0.6	1199	1.4
3.5	940	0.5	1164	1.3
4	907	0.4	1134	1.2
4.5	875	0.3	1102	1.1
5	843	0.2	1069	1.0
5.5	810	0.1	1037	0.9
6	778	0.0	1005	0.7

NOTE: Additional components such as a free cooling coil, hot water reheat coil, or high efficiency filters will reduce available static pressure.

Consider the following in specific applications of duct work to condensing units:

- **In applications where the ceiling plenum is used as the heat rejection domain**, the discharge air must be directed away from the condensing unit air inlet and a screen must be added to the end of the discharge duct to protect service personnel. Locate the air discharge a minimum of 4 feet from an adjacent wall. Failure to do so may result in reduced air flow and poor system performance.
- **If the condensing unit draws air from the outside of the building**, rain hoods must be installed. Hood intake and duct work cross sectional area dimensions should be equal to or greater than the area of the condensing unit intake flange. In addition, install a triple layer bird screen over rain hood openings to eliminate the possibility of insects, birds, water, or debris entering the unit. Avoid directing the hot exhaust air toward adjacent doors or windows.
- Condensing unit fan operation is designed for 3500 CFM (5947 CMH).

5 Piping and Refrigerant Requirements

All field supplied refrigeration piping to the unit must be sweat copper. Use prevailing good piping practices for all connections which include brazing copper pipes using a brazing alloy of minimum temperature of 1,350 °F (732 °C) and adhering to all local codes. All other fluid connections to units, with the exception of the condensate drain, are sweat copper. Factory installed piping brackets must not be removed. Field installed piping must be installed in accordance with local codes and must be properly assembled, supported, isolated, and insulated. Avoid piping runs through noise sensitive areas, such as office walls and conference rooms.

The following pipe connections are required:

- A drain line from the evaporator coil drain pan.
- A drain line from the secondary drain pan (if applicable).
- A water supply line to the optional humidifier (if applicable).
- On split systems systems: refrigerant piping connections between the evaporator unit and the condensing unit.
- On chilled water systems: connections to the building chilled water source. See [Chilled Water Loop Piping](#) on page 31 , for additional requirements.
- On water/glycol systems: connections to a water or glycol loop. See [Water/Glycol Loop Piping](#) on page 32 , for additional requirements.

Refer to specific text and detailed diagrams in this manual for other unit specific piping requirements.

The pipe connection locations, piping general arrangement and schematics are described in the submittal documents included in the [Submittal Drawings](#) on page 105 .

The following tables list the relevant documents by number and title.

Table 5.1 Piping General Arrangement Drawings

Document Number	Title
DPN004412	General Arrangement, Water/Glycol Cooled
DPN004413	General Arrangement, Air Cooled and Chilled Water
DPN000219	General Arrangement, Free Cooling and Hot Water Reheat Options

Table 5.2 Piping Connection Drawings

Document Number	Title
Evaporator and Chilled Water Units	
DPN004304	Piping Connections
Split System Indoor Condensing Units	
DPN004422	Piping Connections, Air Cooled Units
DPN004423	Piping Connections, Water/Glycol Cooled units

5.1 Fluid Piping Required

5.1.1 Drain Line Installation Requirements

NOTICE

Risk of water backing up in the drain line. Leaking and overflowing water can cause equipment and building damage.

Do not install an external trap in the drain line. This line already has a factory installed trap inside the cabinet. Installation of a second trap will prevent drain water flow and will cause the water to overflow the drain pan.

This line may contain boiling water. Use copper or other material that is rated for handling boiling water for the drain line. Sagging condensate drain lines may inadvertently create an external trap.

A 3/4 inch (19.1 mm) NPT female connection is provided for the evaporator unit condensate drain. This connection also drains the humidifier if applicable. The evaporator drain pan includes a float switch to prevent unit operation if the drain becomes blocked.

Observe the following requirements and refer to **Figure 5.1** below, when installing and routing the drain line:

- The drain line must be sized for 2 gpm (7.6 l/m) flow.
- The drain line must be located so it will not be exposed to freezing temperatures.
- The drain should be the full size of the drain connection.
- The drain line must slope continuously away from the unit.
- Do not externally trap the drain line.
- The drain line must be rigid enough that it does not sag between supports, which unintentionally creates traps.
- Use copper or other material suitable for draining water that can reach temperatures up to 212°F (100°C).
- When the evaporator is installed below the level of the gravity fed drain line, the optional condensate pump kit is required. See [Condensate Drain Pump Kit](#) on the next page.

NOTE: Remove the shipping band from the float switch in the evaporator pan before operating the unit.

Figure 5.1 Correct and Incorrect Gravity Drains

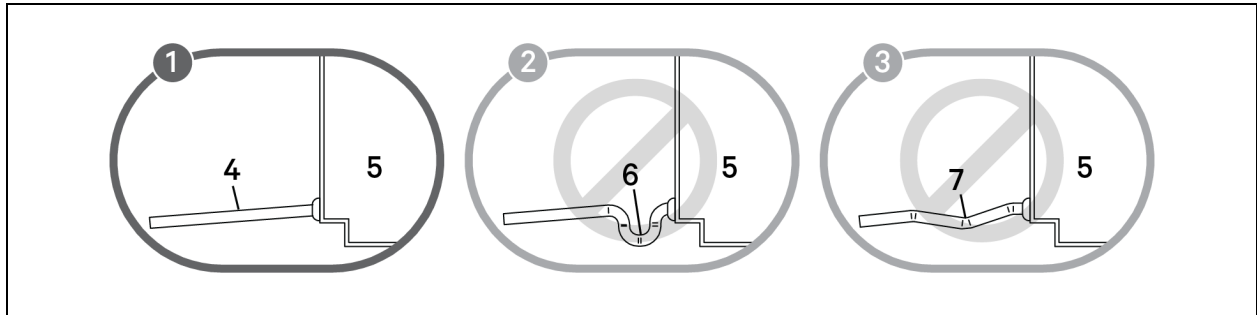

Table 5.3 Gravity-fed Drain Line Figure Descriptions

Item	Description
1	Correct drain installation.
2	Incorrect. Do not trap externally.
3	Incorrect. Sagging between supports and bowed line causes unintentional external traps.
4	Continuous downward slope away from the unit.
5	Unit
6	External trap
7	Unintentional traps from bowing of line. Lines must be rigid enough not to bow or sag between supports, creating a trap.

5.1.2 Condensate Drain Pump Kit



WARNING! Risk of electric shock. Can cause equipment damage, injury, or death. Open all local and remote electric power supply disconnect switches and verify with a voltmeter that power is off before working within any electric connection enclosures. Service and maintenance work must be performed only by properly trained and qualified personnel and in accordance with applicable regulations and manufacturers' specifications. Opening or removing the covers to any equipment may expose personnel to lethal voltages within the unit even when it is apparently not operating and the input wiring is disconnected from the electrical source.

The optional condensate pump kit is required when the evaporator is installed below the level of the gravity fed drain line. The condensate pump is field installed alongside the evaporator unit.

Table 5.4 Condensate Drain Pump Drawings

Document Number	Title
DPN000217	Field installed pump connection

To install the condensate drain pump:

1. Refer to the instructions and drawings supplied with the pump. The preferred mounting method is to attach the pump to the unit with the mounting bracket kit instead of mounting the pump to duct work.
2. Disconnect all power to the unit.
3. Remove the access panels.

NOTE: Remove the shipping band from the float switch in the evaporator pan.

4. Use mounting brackets if the pump is not attached to duct work.
5. The pump inlet must be at least 1/2 inch (13 mm) below the evaporator drain. Mount the pump to the unit exterior as shown in the piping connection diagram for your unit, see **Table 5.4** above.
6. Connect 3/4 inch flexible rubber tubing with a hose clamp (both supplied with pump kit) to the 3/4 inch hose barb fitting on the pump.
7. Connect the evaporator drain to 3/4 inch NPT female hose assembly on the pump inlet using 3/4 inch hard pipe. Do not install a trap in the line. Provide at least 1 inch (25 mm) clearance between the access panel and the drain line. Support the piping as required.
8. Connect a drain line to the pump discharge 3/8 inch O.D. Cu (compression fitting provided).
9. Connect electric leads L1 and L2 to the unit line voltage terminal block. Connect the ground lead to the lug near the terminal block.
10. Connect wires from the auxiliary pump contacts to unit terminals TB1-8 and TB1-9 to enable unit shut down upon high water condition in the pump.
11. Reinstall the access panels.
12. Reconnect power to the unit.
13. Run the unit to make sure the pump works properly. Operate the pump and check the drain line and discharge line for leaks. Correct as needed.

NOTE: 3/4-inch flexible rubber tubing assembly (supplied with pump kit) must be installed on pump end of rigid piping (field provided and supported as required).

5.1.3 Water Supply Line to the Humidifier

Units supplied with the optional humidifier package have a 1/4-inch (6.2-mm) OD copper compression fitting with ferrule at the water supply connection.

- The supply pressure range is 10 psig to 150 psig (69 to 1,034 kPag).
- The required flow rate is 1 gpm (3.8 lpm).
- Install a shut-off valve in the supply line to isolate the humidifier for maintenance.

NOTE: Do not route humidifier water supply line in front of the filter box access panel.

To install the water supply:

1. Cut the tube square and remove any burrs.
2. Slide nut, then the sleeve on tube. The threaded end of the nut faces the end of the tube.
3. Insert the tube into the fitting, seating it against the stop shoulder and tighten the nut hand tight to the body.
4. Use a wrench to tighten the nut 1-1/4 to 2-1/4 turns.

NOTICE

Risk of improper tightening of the piping fittings. Can damage fittings and cause leaks.

Use caution not to over tighten or under tighten the piping fittings.

5.1.4 Chilled Water Loop Piping

NOTICE

Risk of piping system corrosion and freezing fluids. Can cause leaks resulting in equipment and very expensive building damage. Cooling coils and piping systems are at high risk of freezing and premature corrosion. Fluids in these systems must contain the proper antifreeze and inhibitors to prevent freezing and premature coil and piping corrosion. The water or water/glycol solution must be analyzed by a competent local water treatment specialist before start up to establish the inhibitor and antifreeze solution requirement and at regularly scheduled intervals throughout the life of the system to determine the pattern of inhibitor depletion.

The complexity of water/glycol solution condition problems and the variations of required treatment programs make it extremely important to obtain the advice of a competent and experienced water treatment specialist and follow a regularly scheduled coolant fluid system maintenance program.

Water chemistry varies greatly by location, as do the required additives, called inhibitors, that reduce the corrosive effect of the fluids on the piping systems and components. The chemistry of the water used must be considered, because water from some sources may contain corrosive elements that reduce the effectiveness of the inhibited formulation. Sediment deposits prevent the formation of a protective oxide layer on the inside of the coolant system components and piping. The water/coolant fluid must be treated and circulating through the system continuously to prevent the buildup of sediment deposits and or growth of sulfate reducing bacteria.

Proper inhibitor maintenance must be performed in order to prevent corrosion of the system. Consult glycol manufacturer for testing and maintenance of inhibitors.

Commercial ethylene glycol, when pure, is generally less corrosive to the common metals of construction than water itself. It will, however, assume the corrosivity of the water from which it is prepared and may become increasingly corrosive with use if not properly inhibited.

We recommend installing a monitored fluid detection system that is wired to activate the automatic closure of field installed coolant fluid supply and return shut-off valves to reduce the amount of coolant fluid leakage and consequential equipment and building damage. The shut-off valves must be sized to close off against the maximum coolant fluid system pressure in case of a catastrophic fluid leak.

NOTICE

Risk of no flow condition. Can cause equipment damage.

Do not leave the water/coolant fluid supply circuit in a no flow condition. Idle fluid allows the collection of sediment that prevents the formation of a protective oxide layer on the inside of tubes. Keep unit switched On and water/coolant fluid supply circuit system operating continuously.

See **Table 5.5** below , for the chilled water loop requirements.

Install manual service shutoff valves at the supply and return lines of each unit. These shutoff valves are used for routine service and for emergency isolation of the unit.

Refer to the appropriate piping general-arrangement schematics for your system for the recommended, field-installed hardware such as shut-off valves and hose bibs. See **Table 5.1** on page 27 .

NOTE: Chilled water supply and return lines must be insulated to prevent condensation of the lines.

Table 5.5 Requirements for Chilled Water Loop Installation

Minimum Recommended Water Temperature, °F (°C)	Standard Pressure Valve Design Pressure, Psig (Kpag)	High Pressure Valve Design Pressure, Psig (Kpag)	Supply/Return Connection Sizes, in.
42 (5.5)	300 (2068)	400 (2758)	1-1/8 O.D. Cu

5.1.5 Water/Glycol Loop Piping

NOTICE

Risk of frozen pipes and corrosion from improper coolant mixture. Can cause water leaks resulting in equipment and building damage.

When piping or the cooling unit may be exposed to freezing temperatures, charge the system with the proper percentage of glycol and water for the coldest design ambient temperature. Automotive antifreeze is unacceptable and must NOT be used in any glycol fluid system. Use only HVAC glycol solution that meets the requirements of recommended industry practices.

Do not use galvanized pipe.

Install manual service shut-off valves at the supply and return line to each unit. This permits routine service and emergency isolation of the unit. Refer to the appropriate submittal drawing for the piping connection sizes of your unit, see **Table 5.2** on page 27 .

Refer to the appropriate piping general arrangement schematics for your system for the recommended, field installed hardware such as shut-off valves. See **Table 5.1** on page 27.

When the fluid quality is poor, we recommend installing a 16-20# mesh Y-strainer filter in the supply line to extend the service life of the coaxial condensers. These filters must be easily replaced or cleaned.

The standard maximum fluid pressure is 150 psig (1,034 kPa) and 350 psig (2,413 kPa) for high pressure systems. For applications above this pressure, contact a Vertiv representative.

The water/glycol cooled system will operate in conjunction with a cooling tower, city water, or drycooler.

NOTE: HVAC grade ethylene or propylene glycol should be used on glycol systems. Automotive antifreeze must not be used.

Water/Glycol Coolant Regulating Valve

Water/glycol cooled units include a coolant flow regulating valve that is factory adjusted and should not need field adjustment.

Standard pressure and high pressure valves are adjusted differently. Contact Vertiv technical support before making any adjustments.

5.1.6 Free Cooling Coil Piping

An optional, free cooling coil outlet can be field piped to the condensing unit inlet on water cooled systems if a 3-way regulating valve is installed inside the water/glycol condensing unit.

Refer to the appropriate piping general arrangement schematics for your system for the details of a free cooling coil installation. See **Table 5.1** on page 27.

NOTE: If the free cooling coil is piped to an open water tower, a CU/NI (copper-nickel) type coil must be ordered to prevent corrosion of the copper tubes, or a heat exchanger must separate the tower water from the free cooling loop.

5.1.7 Hot Water Reheat Coil Piping

On chilled water systems, building hot water can be piped to a factory installed hot water reheat coil, located downstream of the cooling coil. A factory installed solenoid valve opens upon a call for reheat.

Refer to the appropriate piping general arrangement schematics for your system for the details of a hot water reheat coil installation. See **Table 5.1** on page 27.

5.2 Refrigerant Piping



WARNING! Risk of over-pressurization of the refrigeration system. Can cause piping rupture, explosive discharge of high pressure refrigerant, loss of refrigerant, environmental pollution, equipment damage, injury, or death. This unit contains fluids and gases under high pressure. Use extreme caution when charging the refrigerant system. Do not pressurize the system higher than the design pressure marked on the unit's nameplate. Relieve pressure before cutting into or making connections/disconnections to the piping system. Local building or plumbing codes may require installing a pressure relief device in the system.

Consult local building and plumbing codes for installation requirements of additional pressure relief devices when isolation valves are field installed. Do not isolate any refrigerant circuits from over-pressurization protection. The PFH condensing units include a factory installed pressure relief valve mounted on top of the receiver. The valve is rated for a maximum working pressure of 475 psig.

NOTICE

Risk of oil contamination with water. Can cause equipment damage.

Vertiv™ Liebert® Mini-Mate2 DX systems require the use of POE (polyolester) oil. POE oil absorbs water at a much faster rate when exposed to air than previously used oils. Because water is the enemy of a reliable refrigeration system, extreme care must be used when opening systems during installation or service. If water is absorbed into the POE oil, it will not be easily removed and will not be removed through the normal evacuation process. If the oil is too wet, it may require an oil change. POE oils also have a property that makes them act as a solvent in a refrigeration system. Maintaining system cleanliness is extremely important because the oil will tend to bring any foreign matter back to the compressor.

NOTICE

Risk of improper refrigerant charging. Can cause equipment damage.

Refrigerant charge must be weighed into compressorized systems before they are started.

Split systems require two refrigerant lines between the evaporator and the condensing unit:

- One insulated copper suction line
- One copper liquid line

Observe the following requirements for all field supplied refrigeration piping:

- All piping must be ACR-type copper.
- For all piping connections, use prevailing good piping practices, which includes brazing copper pipes using a brazing alloy of a minimum temperature of 1,350°F (732°C) and adhere to local codes.
- Factory installed piping brackets must not be removed.
- Piping must be installed in accordance with local codes, and must be properly assembled, supported, isolated, and insulated.
- Use prevailing good refrigeration practices such as piping supports, leak testing, evacuation, dehydration and charging of the refrigeration circuits.
- Isolate the refrigeration piping from the building with vibration isolating supports.
- Avoid piping runs through noise sensitive areas such as office walls and conference rooms.
- When sealing openings in walls and to reduce vibration transmission, use a soft, flexible material to pack around the tubes to prevent tube damage.
- When installing remote condensing units above the evaporator, the suction gas lines should be trapped at the evaporator. These traps will retain refrigerant oil in the off cycle. When the unit starts, oil in the traps is carried up the vertical risers and returns to the compressors.

5.2.1 Piping when Condensing Unit is Above or Below Evaporator

Refer to **Table 5.6** below, for the maximum vertical rise/fall between condensing unit and evaporator.

When installing remote condensing units above the evaporator, trap the suction gas line at the evaporator as shown in **Figure 5.2** on the next page. Traps recommended at the base of riser exceeding 5 ft (1.5 m) and every 20 ft (6 m) of vertical rise. This trap will retain refrigerant oil during the Off cycle. When the unit starts, oil in the trap is carried up the vertical riser and returns to the compressor.

When installing remote condensing units below the evaporator, trap the suction gas line with an inverted trap the height of the evaporator as shown **Figure 5.2** on the next page. This prevents refrigerant migration to the compressor during Off cycles. The maximum recommended vertical level drop to condensing unit is 15 feet (4.6 m).

Table 5.6 Pipe Length and Condensing Unit Elevation Relative to Evaporator

Maximum Equivalent Pipe Length, ft (m)	Maximum Condensing Unit Level Above Evaporator, ft (m)	Maximum Condensing Unit Level Below Evaporator, ft (m)
150 (45)	50 (15)	15 (4.6)
Maximum recommended total equivalent pipe length is 150 ft (46 m). Suction and liquid lines may require additional specialty items when vertical lines exceed 20 ft. (6 m) and/or condensing unit installation is more than 15 ft. (4.6 m) below the evaporator. Contact Vertiv Technical Support for assistance.		

Figure 5.2 Refrigerant Piping Diagram when Condenser is Above or Below Evaporator

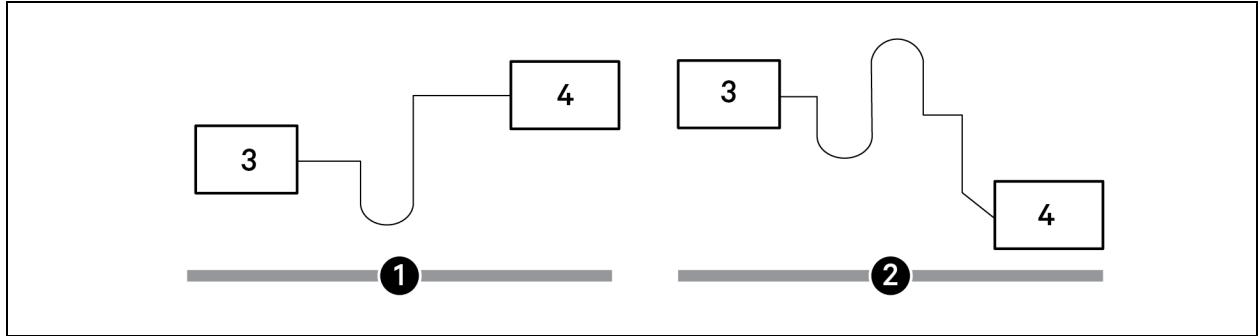

NOTE: Any horizontal pipe must be pitched down toward the condensing unit at a minimum rate of 1/2 inch (13 mm) per 10 feet (3 m) to assure oil return to compressor.

Item	Description
1	Condensing unit above evaporator
2	Condensing unit below evaporator
3	Evaporator
4	Condensing unit

5.2.2 Refrigerant Line Sizes and Equivalent Lengths

The following tables list information required to field install the refrigerant piping for the system.

The pipe connection sizes for your equipment are included in the appropriate submittal documents included in the [Submittal Drawings](#) on page 105.

Table 5.7 Recommended Refrigerant Line Sizes, O.D. cu by Equivalent Length

Equivalent Length, ft(m)	5 Ton	
	Suction	Liquid
50 (15)	1-1/8"	1/2"
75 (23)	1-1/8"	5/8"
100 (30)	1-1/8"	5/8"
125 (38)	1-3/8"	5/8"
150 (45)	1-3/8"	5/8"

1. Consult factory for proper line sizing for runs longer than 150 ft (45 m).

Source: DPN000788 Rev. 16

Table 5.8 Equivalent Lengths for Various Pipe Fittings, ft (m)

Copper Pipe OD, in.	90 Degree Elbow Copper	90 Degree Elbow Cast	45 Degree Elbow	Tee	Gate Valve	Globe Valve	Angle Valve
1/2	0.8 (0.24)	1.3 (0.39)	0.4 (0.12)	2.5 (0.76)	0.26 (0.07)	7.0 (2.13)	4.0 (1.21)
5/8	0.9 (0.27)	1.4 (0.42)	0.5 (0.15)	2.5 (0.76)	0.28 (0.08)	9.5 (2.89)	5.0 (1.52)
3/4	1.0 (0.3)	1.5 (0.45)	0.6 (0.18)	2.5 (0.76)	0.3 (0.09)	12.0 (3.65)	6.5 (1.98)
7/8	1.45 (0.44)	1.8 (0.54)	0.8 (0.24)	3.6 (1.09)	0.36 (0.1)	17.2 (5.24)	9.5 (2.89)
1-1/8	1.85 (0.56)	2.2 (0.67)	1.0 (0.3)	4.6 (1.4)	0.48 (0.14)	22.5 (6.85)	12.0 (3.65)
1-3/8	2.4 (0.73)	2.9 (0.88)	1.3 (0.39)	6.4 (1.95)	0.65 (0.19)	32.0 (9.75)	16.0 (4.87)
1-5/8	2.9 (0.88)	3.5 (1.06)	1.6 (0.48)	7.2 (2.19)	0.72 (0.21)	36.0 (10.97)	19.5 (5.94)

Refrigerant trap = Four times equivalent length of pipe per this table

5.2.3 Refrigerant Charge Requirements

Table 5.9 R-407C Refrigerant Unit Charge

Model #		Charge R-407C, oz (kg)
60 Hz	50 Hz	
MMD60E	MMD59E	4 (0.11)
MMD60K	MMD59K	4 (0.11)
MCD65A	MCD64A	432 (12.3)
MCD69W	MCD68W	94 (2.7)
PFH067A-_LN	PFH066A-_LN	426 (12.1)
PFH067A-_HN	PFH066A-_HN	827 (23.4)
PFHZ67A-_LN	PFHZ66A-_LN	827 (23.4)

1. Use **Table 5.10** below to determine the charge to be added for field-fabricated refrigerant lines.

Table 5.10 Line Charges of R-407C Refrigerant Using Type-L Copper Tube

Line Size, OD, in.	Liquid Line, lb/100 ft (kg/30 m)	Suction Line, lb/100 ft (kg/30 m)
3/8	3.6 (1.6)	—
1/2	6.7 (3.0)	0.2 (0.1)
5/8	10.8 (4.8)	0.3 (0.1)
3/4	16.1 (7.2)	0.4 (0.2)
7/8	22.3 (10.0)	0.5 (0.3)
1-1/8	38.0 (17.0)	0.9 (0.4)
1-3/8	57.9 (25.9)	1.4 (0.7)

Source: DPN003099 Rev. 1

5.2.4 Field Fabricated Refrigeration Piping

Use copper pipe with high temperature brazed joints for all field fabricated refrigeration piping. Use a brazing alloy with a minimum temperature of 1,350°F (732°C), such as Sil-Fos. Avoid soft solders such as 50/50 or 95/5.

1. Measure pipe runs and calculate pipe size and equivalent feet of suction and liquid lines per the tables in [Refrigerant Line Sizes and Equivalent Lengths](#) on page 36 .
2. Determine the type of trap to use on the suction line next to the evaporator based on the position of the condensing unit per [Piping when Condensing Unit is Above or Below Evaporator](#) on page 35 .
3. Determine the number and placement of traps on vertical rises, and install traps on the suction line piping at the base of a rise over 5 feet (1.5-m) and every 20 feet (6-m) of vertical rise.
4. The evaporator and condensing units come with an inert gas holding charge. Release pressure before cutting the spun closed end of the piping.

NOTE: You can only evacuate the system properly if you open the hot gas bypass and liquid line solenoid valves (if equipped) inside the condensing unit and you account for all check valves, see [Figure 5.3](#) on the facing page . Connect manifold gauge hoses to the discharge and suction line Schrader ports, remove the solenoid valve holding coils from the hot gas bypass and liquid line solenoid valves (if equipped), and apply a solenoid valve service magnet to the valves to obtain a proper vacuum.

5. Use a flow of dry nitrogen through the piping during brazing to prevent formation of copper oxide scale inside the piping. A pure dry nitrogen flow of 1 to 3 feet³/min (0.5 to 1.5 l/s) inside the pipe during brazing is sufficient to displace the air. Control the flow using a suitable metering device.

NOTE: Copper oxide forms when copper is heated in the presence of air. POE oil will dissolve these oxides from inside the copper pipes and deposit them throughout the system, clogging filter driers and affecting other system components.

5.2.5 Evacuation and Leak Testing Air Cooled Systems

For proper leak check and evacuation, you must open all system valves and account for all check valves, see [Figure 5.3](#) on the facing page .

Figure 5.3 Valves and Connections

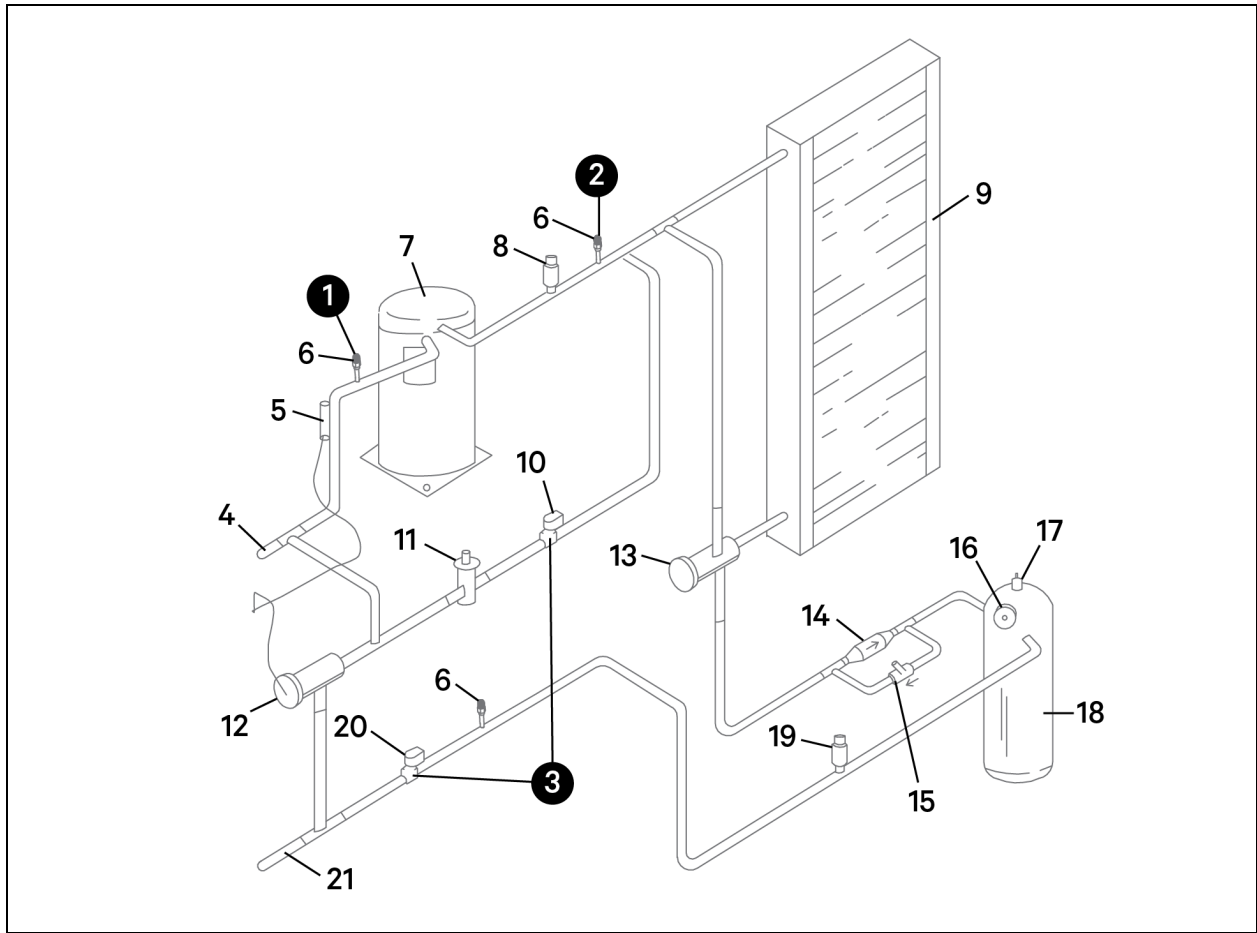

Item	Description
1	Apply a manifold gauge hose on the suction line Schrader port.
2	Apply a manifold gauge hose on the discharge line Schrader port.
3	Unplug the wires and remove the solenoid valve holding coils, then apply solenoid valve service magnets to the valves.
4	Suction line
5	Liquid injection valve bulb
6	Schrader port with valve core NOTE: The system includes a factory installed Schrader valve with core in the liquid line downstream of the receiver. Proper evacuation of the condenser side of the system can be accomplished only using the downstream Schrader valve. See the appropriate piping schematic for your system in Submittal Drawings on page 105 .
7	Scroll compressor
8	High pressure switch
9	Condenser coil
10	Hot gas bypass solenoid valve

Item	Description
11	Hot gas bypass control valve
12	Liquid injection
13	3-way head-pressure control valve
14	Check valve
15	Pressure balancing valve
16	Sight glass
17	Pressure relief valve
18	Lee-Temp receiver
19	Receiver heater pressure-limiting switch
20	Liquid line solenoid valve
21	Liquid line

To evacuate and leak test the system:

1. Open the liquid line solenoid valve and hot gas bypass solenoid valve by removing the holding coils, and apply a solenoid valve service magnet to the valves.
2. Connect manifold gauge hoses on the discharge and suction line Schrader ports, open the service valves, and place a 150 Psig (1,034 kPa) charge of dry nitrogen with a tracer of refrigerant, then check the system for leaks with a suitable leak detector.
3. After completion of leak testing, release the test pressure, (observe local code) and pull an initial deep vacuum of 500 microns on the system with a suitable pump.
4. After four hours, check the pressure readings and, if they have not changed, break vacuum with dry nitrogen. Pull a second and third vacuum to 500 microns or less. Re-check the pressure after two hours. When the three checks are complete, proceed to [Charging Air Cooled Systems](#) below .

5.2.6 Charging Air Cooled Systems

NOTICE

Risk of improper refrigerant charging. Can cause equipment damage.

R-407C is a blended refrigerant and must be introduced and charged from the cylinder only as a liquid.

When adding liquid refrigerant to an operating system, it may be necessary to add the refrigerant through the valve in the compressor suction line. Care must be exercised to avoid damage to the compressor. We recommend connecting a sight glass between the charging hose and the compressor suction service valve. This will permit adjustment of the cylinder hand valve so that liquid can leave the cylinder while allowing vapor to enter the compressor.

To calculate the charge for the system:

1. Check the nameplate on the indoor unit for refrigerant type to use.
2. Refer to **Table 5.9** on page 37 , and **Table 5.10** on page 37 , and calculate the amount of charge for the system including the evaporator, condensing unit, and interconnecting piping.
3. Accurately weigh-in as much of the system charge as possible before re-installing coils on liquid line solenoid valve and hot gas bypass solenoid valve, and starting the unit.

5.2.7 Field Charge Verification for Air Cooled Systems

An integral sight glass is provided with the receiver to assist in field charge verification. During charge verification, set the control temperature down to keep the system running. If the system is equipped with hot gas bypass, de-energize it by removing power from the hot gas solenoid valve coil. To remove power, disconnect the solenoid leads from the unit contactor in the electric box, see **Figure 5.3** on page 39. When charge verification is complete, replace and secure all wire connections and covers.

During operation at design ambient temperatures, (95 or 105°F; 35 or 41°C) the charge level is above the sight glass in the receiver. If levels are below the sight glass, an under charge condition is likely. If levels are above the sight glass and higher discharge pressures than normal are observed, an overcharge condition may be likely. However, verify that other high discharge pressure causes such as dirty coil and restricted air flow are not responsible before removing charge.

At temperatures below design ambient temperature, refrigerant backs into the condenser coil and the level in the receiver drops below the sight glass. If you are trying to verify charge level at lower ambient temperatures, block the condenser coil to maintain 240 psig (1,655 kPa) discharge pressure to ensure the head pressure control valve is closed. At these conditions the charge level should be above the sight glass in the receiver.

NOTE: If no level is visible in the sight glass, add charge until the level is in the middle of the sight glass. Check the discharge pressure during this procedure and adjust coil restrictions to maintain 240 psig (1,655 kPa). Once the charge is in the middle of the sight glass, add additional system charge per **Table 5.11 below. After charging, unblock the coil and allow the unit to operate normally. After conditions have stabilized, restrict the coil if required to maintain 240 psig (1,655 kPa) discharge pressure and verify that the charge level is above the sight glass.**

NOTE: The high ambient and Quiet-Line models consist of two condenser coils and two receivers. When restricting airflow on these units, the coils should be blocked off proportionally. If one coil is restricted significantly more than the other, liquid can remain in the restricted coil causing lower levels in the receivers. The receiver liquid level should be above the sight glasses in both receivers. There may be some variation in charge level between the two receiver sight glasses due to piping and assembly variations. When adding charge, determine which receiver level is lower and use that sight glass to gauge charge level.

Table 5.11 Field Verification Charge Addition

Model Numbers		R-407C
60Hz	50Hz	oz (kg)
PFH067A-_L	PFH066A-_L	18 (0.51)
MCD65A	MCD64A	18 (0.51)
PFH067A-_H	PFH066A-_H	50 (1.42)
PFHZ67A-_L	PFHZ66A-_L	50 (1.42)

See [R-407C Refrigerant Unit Charge](#) on page 37, for base charge amount of the condensing unit.

5.2.8 Documenting Refrigerant Charge on Air Cooled Units

When the unit is charged, you must record the total system charge value on the condensing unit's serial tag. The total system charge includes the evaporator, condensing unit, and interconnecting lines.

5.2.9 Evacuation and Leak Testing Water/Glycol Cooled Systems

For proper leak check and evacuation, you must open all system valves and account for all check valves, see **Figure 5.4** on the next page.

Figure 5.4 Valves and Connections for Remote Water/Glycol Condensing Unit

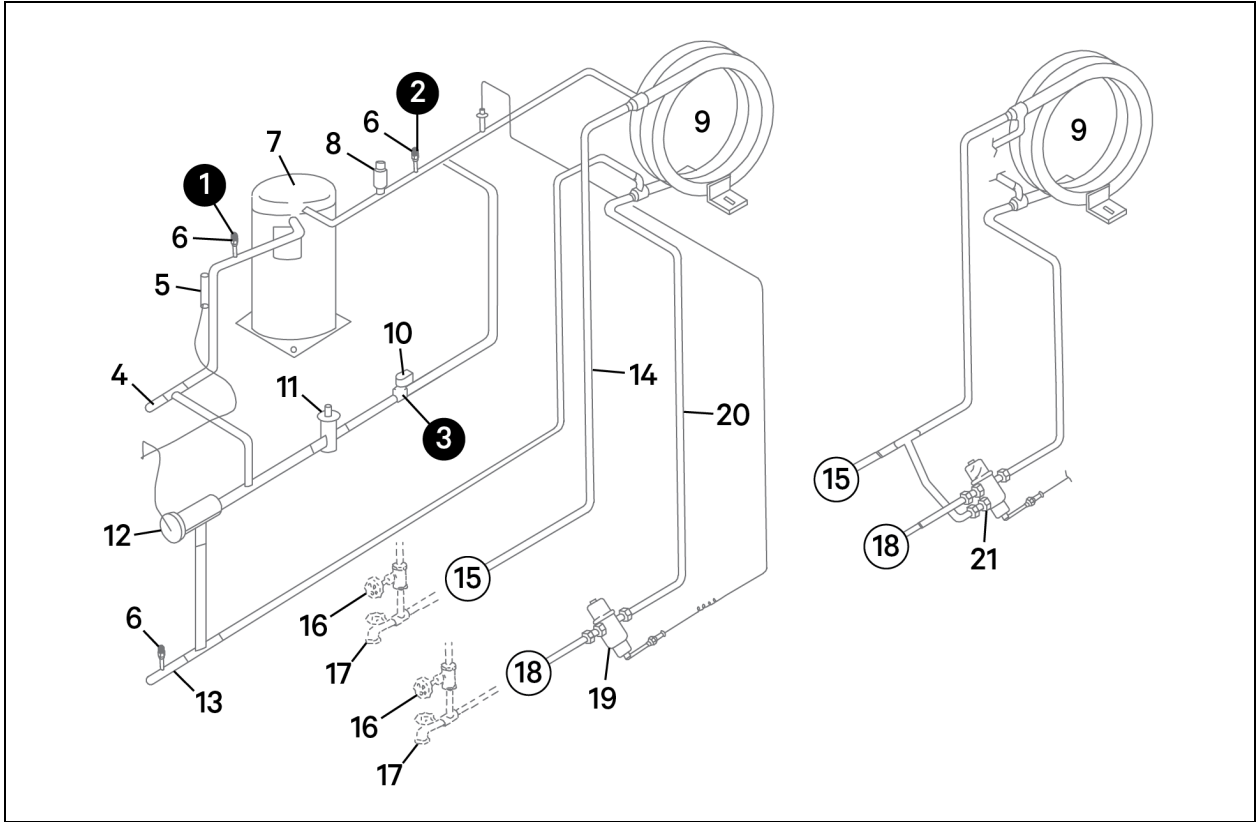

Item	Description
1	Apply a manifold gauge hose on the suction line Schrader port.
2	Apply a manifold gauge hose on the discharge line Schrader port.
3	Unplug the wires and remove the solenoid valve holding coil, then apply a solenoid valve service magnet to the valve.
4	Suction line
5	Liquid injection valve bulb
6	Schrader port with valve core
7	Scroll compressor
8	High pressure switch
9	Tube-in-tube condenser
10	Hot gas bypass solenoid valve
11	Hot gas bypass control valve
12	Liquid injection
13	Liquid line
14	Water/Glycol return line

Item	Description
15	Fluid return from unit
16	Shut-off valves (required, field-supplied)
17	Hose bibs (required, field-supplied)
18	Fluid supply to unit
19	2-way water regulating valve
20	Water/Glycol supply line
21	3-way water regulating valve (optional)

To evacuate and leak test the system:

1. Open the hot gas bypass solenoid valve by removing the holding coil, and apply a solenoid valve service magnet to the valve.
2. Connect a manifold gauge hose on the discharge and suction line Schrader ports, open the service valve, and place a 150 Psig (1,034 kPa) charge of dry nitrogen with a tracer of refrigerant, then check the system for leaks with a suitable leak detector.
3. After completion of leak testing, release the test pressure, (observe local code) and pull an initial deep vacuum of 500 microns on the system with a suitable pump.
4. After four hours, check the pressure readings and, if they have not changed, break vacuum with dry nitrogen. Pull a second and third vacuum to 500 microns or less. Re-check the pressure after two hours.
When the three checks are complete, and proceed to [Charging Water/Glycol Cooled Systems](#) below .

5.2.10 Charging Water/Glycol Cooled Systems

NOTICE

Risk of improper refrigerant charging. Can cause equipment damage.

R-407C is a blended refrigerant and must be introduced and charged from the cylinder only as a liquid.

When adding liquid refrigerant to an operating system, it may be necessary to add the refrigerant through the valve in the compressor suction line. Care must be exercised to avoid damage to the compressor. We recommend connecting a sight glass between the charging hose and the compressor suction service valve. This will permit adjustment of the cylinder hand valve so that liquid can leave the cylinder while allowing vapor to enter the compressor.

To calculate the charge for the system:

1. Check the nameplate on the indoor unit for refrigerant type to use.
2. Refer to **Table 5.9** on page 37 , and **Table 5.10** on page 37 , and calculate the amount of charge for the system including the evaporator, condensing unit, and interconnecting piping.
3. Accurately weigh-in as much of the system charge as possible before re-installing the coil on the hot gas by pass solenoid valve and starting the unit.

5.2.11 Optimizing Refrigerant Charge on Water/Glycol Units

1. Operate the unit at full heat load, normal room conditions and normal water/glycol fluid temperatures for a minimum of 30 minutes before measuring stable unit superheat and sub-cooling temperatures and adjusting charge levels.
 - Condensing temperatures should be in range of 100 to 130°F (38 to 54°C) depending on fluid type and fluid temperature.
 - Full heat load is required to stabilize the system.
2. Attach pressure and temperature instruments to the liquid line of the condensing unit. Use the factory installed Schrader valve located in the liquid line of the condenser. Measure the initial sub-cooling.

NOTE: To determine sub-cooling measurement, a liquid line pressure reading (at the factory installed Schrader tap) must be measured along with the temperature reading on the liquid line. Convert the liquid line pressure reading into a liquid temperature by utilizing a pressure temperature guide. Subtract the measured temperature from the liquid saturation temperature. The difference is sub-cooling.

3. Adjust refrigerant charge levels as needed to achieve sub-cooling range of 12 to 14°F (6.7 to 7.8°C) while maintaining full load conditions.

5.2.12 Documenting Refrigerant Charge on Water/Glycol Cooled Units

When the unit is charged, you must record the total system charge value on the condensing unit's serial tag. The total system charge includes the evaporator, condensing unit, and interconnecting lines.

6 Electrical Connection Requirements



WARNING! Arc flash and electric shock hazard. Open all local and remote electric power supply disconnect switches, verify with a voltmeter that power is Off and wear appropriate, OSHA approved personal protective equipment (PPE) per NFPA 70E before working within the electric control enclosure. Failure to comply can cause serious injury or death. Customer must provide earth ground to unit, per NEC, CEC and local codes, as applicable. Before proceeding with installation, read all instructions, verify that all the parts are included and check the nameplate to be sure the voltage matches available utility power. The Vertiv™ Liebert® iCOM™ controller does not isolate power from the unit, even in the Unit Off mode. Some internal components require and receive power even during the Unit Off mode of the controller. The only way to ensure that there is NO voltage inside the unit is to install and open a remote disconnect switch. Refer to unit electrical schematic. Follow all local codes.



WARNING! Risk of improper wire and loose electrical connections. Can cause overheated wire and electrical connection terminals resulting in smoke, fire, equipment and building damage, injury or death. Use correctly sized copper wire only and verify that all electrical connections are tight before turning power On. Check all electrical connections periodically and tighten as necessary.

NOTE: Seal openings around piping and electrical connections to prevent air leakage. Failure to do so could reduce the unit's cooling performance.

NOTICE

Risk of improper electrical supply connection. Can cause equipment damage.

See transformer label for primary tap connections. Installer will need to change transformer primary taps if applied unit voltage is other than pre-wired tap voltage.

Three-phase electrical service is required for all models. All power and control wiring and ground connections must be in accordance with the National Electrical Code and local codes. Refer to the equipment serial-tag data for electrical requirements.

A manual electrical disconnect switch should be installed in accordance with local codes and distribution system. Consult local codes for external disconnect requirements.

NOTE: Input power requirements: For 3-phase units, only three power wires and an earth ground are required.

Each unit is shipped from the factory with internal wiring completed. Refer to the unit's electrical schematic when making connections. Electrical connections to be supplied by the users and made at the installation site are:

- Power supply to each ceiling unit.
- Power supply to outdoor condensing unit, if applicable.
- Control wiring (shielded) between the evaporator unit and condensing unit, if applicable.
- Control wiring (shielded) between the control panel (wall box) and the evaporator or chilled water unit's control board.

The electrical connections are described in the submittal documents included in the [Submittal Drawings](#) on page 105.

The following table lists the relevant documents by number and title.

Table 6.1 Electrical Field Connection Drawings

Document Number	Title
Evaporator and Chilled Water Units	
DPN000221	Electrical Connections
DPN000220	Single Point Power Kit for Close Coupled Units
DPN004852	Arrangement and Dimensions, Unit Mounted IS-UNITY-DP for BMS Communication
DPN004911	Arrangement and Dimensions, Wall Mounted IS-UNITY-DP for BMS Communication
DPN004854	Electrical Connections, IS-UNITY-DP for BMS Communication
Split System Indoor Condensing Units	
DPN004297	Electrical Connections, Air Cooled Units
DPN004298	Electrical Connections, Water/Glycol Cooled Units

6.1 Input Power Connection Requirements



WARNING! Risk of loose electrical connections. Can cause overheating of wire, smoke, and fire resulting in building and equipment damage, injury, or death. Use copper wiring only. Verify that all connections are tight.

NOTE: Refer to specifications for full load amp. and wire size amp. ratings.

Voltage supplied must agree with the voltage specified on the unit serial tag. If a field supplied disconnect switch is required, it may be bolted to the ceiling unit, but not to any of the removable panels. This would interfere with access to the unit. Make sure that no refrigerant lines are punctured when mounting the disconnect switch.

Route the electrical service conduit through the hole provided in the cabinet and terminate it at the electric box. Make connections at the factory terminal block or disconnect switch, L1, L2, L3. Connect earth ground to lug provided. See transformer label for primary tap connections. Installer will need to change transformer primary taps if applied unit voltage is other than pre-wired tap voltage. For 208-VAC applications, the low voltage transformer tap must be changed. Refer to the electrical schematic.

An optional single point power kit is available for units that are close coupled (See [Close Coupled Installations for Indoor Condensing Units](#) on page 23). This kit should be mounted inside the condensing unit before installing the unit in the ceiling. Specific installation instructions are included with the single point power kit.

6.2 Control Wiring Connection Requirements

6.2.1 Wall Box Controller Control Connections

A four conductor (thermostat type) field supplied, shielded wire must be connected between the evaporator control board and the wall box display. Refer to the appropriate submittal drawings for your system for electrical connections. See **Table 6.1** on the previous page .

6.2.2 Split System Condensing Unit Control Connections

A field supplied, shielded, 4-wire control connection (24 VAC) is required between the evaporator and the condensing unit.

Control wiring must be installed in accordance with the National Electrical Code (NEC) Class 1 or Class 2 circuit according to wire routing conditions chosen and local codes. Water/Glycol cooled units require a Class 1 circuit. If installing a Glycol unit, see [Water/Glycol Cooled Unit Control Connections](#) below , for specific requirements.

Control wiring between the evaporator and the condensing unit must be shielded and sized for a voltage drop of less than 1 volt, see **Table 6.2** below , for recommended minimum gauge by distance. Connect the shield wire to earth (ground) at the Liebert® equipment. Avoid running the low voltage connections near high voltage lines or loads such as light ballasts.

NOTE: Do not connect additional electrical devices to the control circuit. The internal control transformer is only sized for factory supplied components. Refer to the appropriate submittal drawings for your system for electrical connections. See **Table 6.1 on the previous page .**

Table 6.2 Recommended Minimum Wire Size

Maximum Distance,* ft (m)	Minimum Wire Gauge, AWG (mm ²)
50 (15)	20 (0.75)
75 (23)	18 (1.0)
100 (30)	18 (1.0)
150 (45)	16 (1.5)
* One-way control wire run between outdoor condensing unit and evaporator.	

6.2.3 Water/Glycol Cooled Unit Control Connections

Glycol cooled units require an additional field supplied, 2 conductor (thermostat type) wire connection between the evaporator unit and the drycooler. Units with water tower loops can be wired for circulation pump/valve requirement. A Class 1 circuit is required for Water/Glycol units. Control wiring must be installed in accordance with NEC and local codes. Refer to the appropriate submittal drawings for your system for electrical connections. See **Table 6.1** on the previous page .

6.2.4 Additional Control Connections

If your system includes other optional monitoring and control devices, additional control wiring will be required.

This page intentionally left blank

7 Checklist for Completed Installation

1. Proper clearances for service access have been maintained around the equipment.
2. Equipment is level and mounting fasteners are tight.
3. Piping completed to refrigerant or coolant loop (if required). Refrigerant charge added.
4. Condensate pump installed (if required).
5. Drain line(s) connected and checked for leaks.
6. Water supply line connected to humidifier (if required). Routed to allow air filter removal.
7. All piping connections are checked for leaks. (Correct as required.)
8. Field provided, water tight, secondary drain pan with drain is installed under all cooling units and ceiling mounted water/glycol condensing units.
9. Drain from secondary drain pan is routed to a frequently used maintenance sink with signs posted to alert people to report water/glycol flowing from drain pan.
10. Filter box installed on ducted units.
11. Ducting completed.
12. Filters installed in return air duct.
13. Line voltage to power wiring matches equipment serial tag.
14. Power wiring connections completed between disconnect switch, evaporator and condensing unit, including earth ground.
15. Power line circuit breakers or fuses have proper ratings for equipment installed.
16. Wall mounted control is mounted and wired to the cooling unit.
17. Shielded control wiring connections used and completed to evaporator and condensing unit (if required), including wiring to wall mounted control panel and optional controls.
18. Control panel DIP switches set based on customer requirements.
19. All wiring connections are tight.
20. Foreign materials have been removed from inside and around all equipment installed (shipping materials, construction materials, tools, etc.).
21. Fans and blowers rotate freely without unusual noise.
22. Inspect all piping connections for leaks during initial operation. Correct as needed.
23. Rubber band is removed from evaporator condensate pan float switch.

This page intentionally left blank

8 Initial Start-up Checks and Commissioning Procedure for Warranty Inspection



WARNING! Arc flash and electric shock hazard. Open all local and remote electric power supply disconnect switches, verify with a voltmeter that power is Off and wear appropriate, OSHA approved personal protective equipment (PPE) per NFPA 70E before working within the electric control enclosure. Failure to comply can cause serious injury or death. Customer must provide earth ground to unit, per NEC, CEC and local codes, as applicable. Before proceeding with installation, read all instructions, verify that all the parts are included and check the nameplate to be sure the voltage matches available utility power. The Vertiv™ Liebert® iCOM™ controller does not isolate power from the unit, even in the Unit Off mode. Some internal components require and receive power even during the Unit Off mode of the controller. The only way to ensure that there is NO voltage inside the unit is to install and open a remote disconnect switch. Refer to unit electrical schematic. Follow all local codes.



WARNING! Risk of improper wiring, piping, moving, lifting, and handling. Can cause equipment damage, serious injury, or death. Installation and service of this equipment should be done only by qualified personnel, wearing appropriate, OSHA approved PPE, who have been specially trained in the installation of air conditioning equipment.

- Confirm that all items on [Checklist for Completed Installation](#) on page 49, have been done.
- Locate Vertiv™ Liebert® Mini-Mate2 Warranty Inspection Check Sheet in the unit's electric panel. (PSWI-8542-409CO).
- Complete Liebert® Mini-Mate2 Warranty Inspection Check Sheet during start-up. (PSWI-8542-409CO).
- Forward the completed Liebert® Mini-Mate2 Warranty Inspection Check Sheet to your local sales office. **This information must be completed and forwarded to validate warranty.**
- Contact your local sales representative or technical support if you have any questions or problems during unit start-up and commissioning. Visit <https://www.vertiv.com/en-us/support/> or call 1-800-543-2778 for contacts.

This page intentionally left blank

9 Microprocessor Control

The Microprocessor Control for the Vertiv™ Liebert® Mini-Mate2 features a menu driven LCD. The menus, control features, and circuit board are described in this section. Detailed information concerning controls ([System Control and Performance](#) on page 71) and alarms ([Alarm Notification, Acknowledgment, and Descriptions](#) on page 74) are provided.

9.1 Controller Operation

Setpoints, DIP switch settings, and other selections were made during factory testing of your unit and are based upon typical operating experience. Other default selections were made according to options included with your unit.

NOTE: Only make adjustments to the factory default settings if they do not meet your specifications.

When adjusting setpoints and configuration, allowable ranges are displayed by pressing the help key. If enabled, a password is required to change setpoints, time delays, and other settings.

The default display normally shows the present room temperature, humidity, active status functions (cooling, heating, dehumidifying, humidifying), fan speed, and active alarms.

The controller includes an LCD display and 7 buttons to navigate the display.

Figure 9.1 Control Keys on the Wall Mounted Display

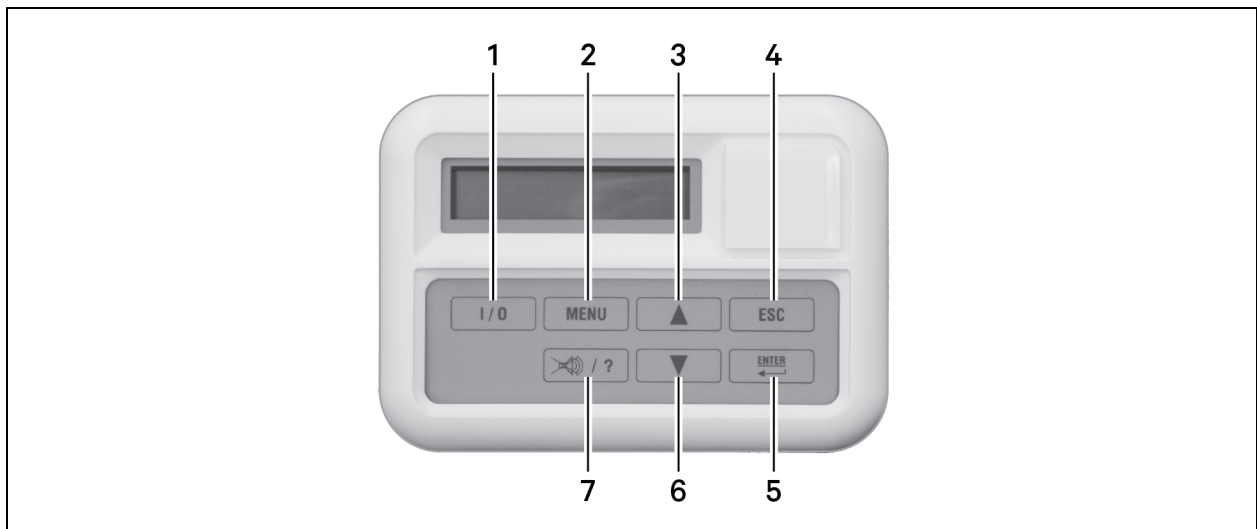

Item	Description
1	I/O (On/Off)
2	Menu, displays program menu
3	Up arrow, increases parameter value in a settings mode
4	Escape, backs-up to a preview menu
5	Enter, saves settings/changes
6	Down arrow, decreases parameter value in a settings mode
7	Alarm Silence/Help, silences active alarm(s). Displays help text when there is no alarm.

9.1.1 Powering On/Off with Wall Mounted Display

To power on the system:

Press I/O after power is applied.

To power off the system:

Press I/O before power is disconnected.

9.1.2 Silencing an Audible Alarm

Active alarms are displayed on the LCD screen and sound an audible beeper.

To silence an audible alarm:

Press the Alarm Silence/Help button.

The alarm notification remains visible on the LCD screen.

9.2 Main Menu <MENU>

The menu options are shown in **Figure 9.2** on page 56 . The options differ only slightly depending on the size of the unit. The differences are noted in the option descriptions.

To select a menu option:

1. Press the *MENU* key.
2. Use the Up/Down arrows to highlight a selection, then press *Enter*.

Main Menu Options

SETPOINTS

See [Editing Setpoints](#) on page 57 .

STATUS

See [Viewing Unit Status](#) on page 57 .

ACTIVE ALARMS

See [Viewing Active Alarms](#) on page 58 .

TIME

See [Setting Controller Time](#) on page 58 .

DATE

See [Setting Controller Date](#) on page 58 .

SETBACK

See [Programming Setback](#) on page 58 .

SETUP OPERATION

See [Editing Setup Operation](#) on page 59

SETPOINT PASSWORD

See [Changing Setpoint and Setup Passwords](#) on page 61

SETUP PASSWORD

See [Changing Setpoint and Setup Passwords](#) on page 61 .

CALIBRATE SENSORS

See [Calibrating Sensors and Setting Sensor Response Delay](#) on page 62 .

ALARM ENABLE

See [Enabling/Disabling Alarms](#) on page 63 .

ALARM TIME DELAY

See [Setting Alarm Delays](#) on page 63 .

COMMON ALARM ENABLE

See [Activating the Common Alarm Relay](#) on page 64 .

CUSTOM ALARMS

See [Configuring Custom Alarms](#) on page 64 .

CUSTOM TEXT

See [Customizing Alarm Message Text](#) on page 65 .

DIAGNOSTICS

See [Running Diagnostics](#) on page 66 .

Figure 9.2 Control Menu Example

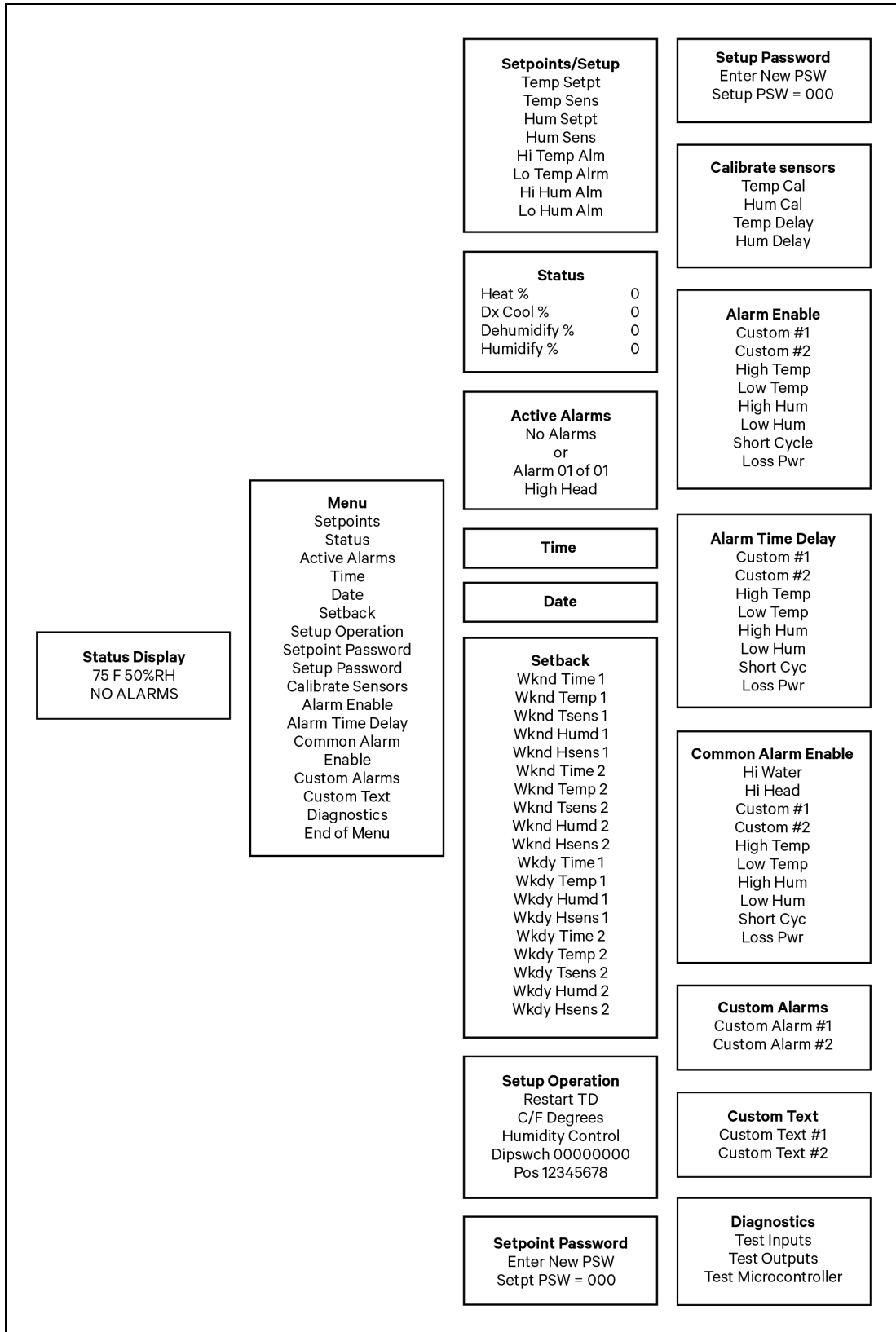

9.2.1 Editing Setpoints

Setpoints are kept in non-volatile memory. The setpoint options are:

- TEMPERATURE SETPOINT
- TEMPERATURE SENSITIVITY
- HUMIDITY SETPOINT
- HUMIDITY SENSITIVITY
- HIGH TEMPERATURE ALARM
- LOW TEMPERATURE ALARM
- HIGH HUMIDITY ALARM
- LOW HUMIDITY ALARM

Table 9.1 below, lists the default setting and allowed range for each setpoint.

Table 9.1 Default Setpoints and Allowable Ranges

Setpoint	Default	Range
Temperature Setpoint	72°F	40-90°F (5-32°C)
Temperature Sensitivity	2.0°F	1-9.9°F (0.6-5.6°C)
Humidity Setpoint	50%	20-80% RH
Humidity Sensitivity	5%	1-30% RH
High Temperature Alarm	80°F	35-95°F (2-35°C)
Low Temperature Alarm	65°F	35-95°F (2-35°C)
High Humidity Alarm	60%	15-85% RH
Low Humidity Alarm	40%	15-85% RH

To adjust a setpoint:

1. Press the *MENU* key.
2. Use the Up/Down arrows to highlight SETPOINTS, then press *Enter*.
3. Use the Up/Down arrows to highlight a setpoint option, then press *Enter*.
4. Use the Up/Down arrows to change the value, then press *Enter* to store the value.

9.2.2 Viewing Unit Status

The Status options displays percentage heating, cooling, dehumidifying, and humidifying status of the unit.

To view the unit status:

1. Press the *MENU* key.
2. Use the Up/Down arrows to highlight STATUS, then press *Enter*.

9.2.3 Viewing Active Alarms

Alarms display on the LCD as No Alarm Present or Alarm XX of YY, where XX is the number of the alarm and YY is the total number of active alarms.

To view active alarms:

1. Press the *MENU* key.
2. Use the Up/Down arrows to highlight ACTIVE ALARMS, then press *Enter*.
3. If there is more than one active alarm, use the Up/Down Arrows to scroll through the alarms list.

9.2.4 Setting Controller Time

The controller time clock must be set to allow for the setback control. The clock uses the 24-hour system (that is, 12 midnight is entered as 24:00).

To set the time:

1. Press the *MENU* key.
2. Use the Up/Down arrows to highlight TIME, then press *Enter*.
3. Use the Up/Down arrows to change each character, pressing *Enter* to store it and move to the next character.

NOTE: Date and Time features have a battery back-up.

9.2.5 Setting Controller Date

The controller date must be set to allow for the setback control.

To set the date:

1. Press the *MENU* key.
2. Use the Up/Down arrows to highlight DATE, then press *Enter*.
3. Use the Up/Down arrows to change each character, pressing *Enter* to store it and move to the next character.

NOTE: Date and Time features have a battery back-up.

9.2.6 Programming Setback

The microprocessor can be programmed for night and weekend setback. Two events can be programmed for a five day work week and two events can be programmed for a two day weekend. Use **Table 9.2** on the facing page, to devise a setback plan.

To program a setback plan:

1. Press the *MENU* key.
2. Use the Up/Down arrows to highlight *SETBACK*, then press *Enter*.
3. Use the Up/Down arrows to change the values, then press *Enter* to store the value.

Table 9.2 Night and Weekend Setback Plan

Event	Weekend	Weekday
Time 1		
Temperature 1		
Sensitivity 1		
Humidity 1		
Humidity Sensitivity 1		
Time 2		
Temperature 2		
Sensitivity 2		
Humidity 2		
Humidity Sensitivity 2		

9.2.7 Editing Setup Operation

System setup parameters are kept in non-volatile memory.

To edit the setup:

1. Press the *MENU* key.
2. Use the Up/Down arrows to highlight *SETUP OPERATION*, then press *Enter*.
3. Use the Up/Down arrows to highlight a setup option, then press *Enter*.
4. Use the Up/Down arrows to change the value, then press *Enter* to store the value.

Table 9.3 below, lists the default setting and allowed range for each function.

Table 9.3 Setup Functions, Default Values and Allowable Ranges

Function	Default	Range
Restart Time Delay	0.1 min	0 to 9.9 min (0 = manual restart)
C/F Degrees	°F	°C or °F
Humidity Control	Rel	Relative or Absolute
CW Valve Travel Time	165 seconds	50 to 250 seconds
CW Flush Interval	24 hours	0 to 99 hours

Setup options

RESTART TIME DELAY

Selects a delay before restarting the unit after main power is restored to the unit.

- Delay can be set from 0.1 minutes (6 seconds) to 9.9 minutes.
- If several units are operating, set different delays for a sequential startup.
- Setting the value to zero (0) prevents unit restart when power is restored. In this case, the unit must be restarted manually by pressing the On/Off button on the keypad.

C/F DEGREES

Selects Fahrenheit (F) or Celsius (C) for display readings/setpoints.

HUMIDITY CONTROL METHOD

Selects relative (direct) or absolute (predictive) for humidity control. The LCD displays the percentage relative humidity for both methods of control and if absolute is selected, the adjusted humidity reading is also displayed.

- If relative is selected, the RH control is taken directly from the RH sensor.
- If absolute is selected, the RH control automatically adjusts when return air temperature deviates from the desired temperature setpoint (i.e., predictive humidity control). Predictive humidity control automatically adjusts the humidity level ~2% RH for each degree difference between the return air temperature and the temperature setpoint.

For more details about selecting the humidity control method, see [Humidity Control and Over-cooling](#) on the facing page .

SHOW DIPSWITCH

Displays the position of the DIP switches on the unit's control board

- 1 = Switch is ON
- 0 = Switch is OFF.

For more information on the DIP switches and their functions, see [Equipment Options DIP Switches](#) on page 65 .

CW VALVE TRAVEL TIME

On systems with a modulating, chilled water valve, shows the full valve travel time of the modulating valve. This is the time it takes for the valve to travel from full closed to full open.

Programmable from 50 to 250 seconds, the factory default time is 165 seconds and should not be changed. The valve travel time is used by the control to determine the appropriate valve position. For example, if the valve travel time is 165 seconds and the call is for 50% cooling, the valve opens for 83 seconds to achieve 50% open/cooling.

CW FLUSH INTERVAL

On systems with a modulating, chilled water valve, shows the interval of the system flush cycle.

The factory default is 24 (hours) and is programmable from 0 (hours), which means never flush, to 99 (hours), which flushes after every 99 hours of valve non-use. If the valve opens within the programmed interval time, the timer resets to 0. The flush cycle is active even when the fan is turned off but power is applied to the unit. When the interval timer reaches the programmed time, the valve opens for three minutes to flush any contaminants that may have collected in the system.

Humidity Control and Over-cooling

When using the relative (direct) humidity control method, unnecessary dehumidification can result when over-cooling occurs during a dehumidification cycle. This happens when a higher-than-normal RH reading is caused by over-cooling the room (about 2% RH for each degree of over cooling). This temperature drop extends the dehumidification cycle. Later, when dehumidification ends and the temperature rises to the setpoint, the RH reading falls to a reading lower than actually desired. If the temperature drop significant enough, the percentage RH could be low enough to activate the humidifier.

Using the absolute (predictive) humidity method may avoid over-dehumidification. When over-cooling causes an increase in the RH reading, the humidity-control program estimates what the RH will be when the dehumidification cycle ends and temperature returns to the setpoint and allows the dehumidification cycle to end at the proper time. Predictive humidity control can greatly reduce energy consumption by minimizing compressor/reheat operation and eliminating unnecessary operation.

9.2.8 Changing Setpoint and Setup Passwords

When you attempt to make changes, the display prompts you for a three digit password. The passwords provide system security, so that only authorized personnel may make changes. If unauthorized changes occur, the passwords may be compromised and new ones should be set.

The system includes two passwords with the following factory default settings:

- Default setup password = 3 - 2 - 1
- Default setpoint password = 1 - 2 - 3

To change a password:

First enter the default password, then enter the new password.

NOTE: The password function can be disabled by setting DIP switch 8 in the wall box to OFF and then cycling power to the unit.

9.2.9 Calibrating Sensors and Setting Sensor Response Delay

If you suspect that the temperature and/or humidity readings are not accurate, you can calibrate the sensors to match the display using your portable, calibrated test instrument and the CALIBRATE SENSORS menu. The temperature sensor can be calibrated $\pm 5^{\circ}\text{F}$. The humidity sensor can be calibrated $\pm 10\%$ RH.

If the sensors are subject to frequent wide temperature and humidity swings, it may be necessary to shorten the cycling by increasing the sensor time delay. If the sensors are located too close to the air discharge, they will likely experience rapid swings in measurement. Another method in reducing compressor cycling is to increase the temperature and/or humidity sensitivity.

The calibration and delay options are:

- SET TEMP CAL—calibrates the temperature sensor $\pm 5^{\circ}\text{F}$ ($\pm 2.8^{\circ}\text{C}$).
- SET HUM CAL—calibrates the humidity sensor $\pm 10\%$.
- SET TEMP DELAY—sets the time delay for sensor response 10 to 90 seconds (default setting = 50 seconds).
- SET HUMID DELAY—sets the time delay for sensor response 10 to 90 seconds (default setting = 50 seconds).

To calibrate a sensor:

1. Make sure the unit is operating and has maintained stable operating conditions for at least 15 minutes.
2. Place the test instrument as close as possible to the sensors to obtain an accurate reading for comparison.
3. At the controller, press the MENU key.
4. Use the Up/Down arrows to highlight CALIBRATE SENSORS, then press *Enter*.
5. Use the Up/Down arrows to highlight a calibration option, then press *Enter*.
6. Use the Up/Down arrows to adjust the unit's sensor reading to match the reading from the test device, then press *Enter* to store the value.

IMPORTANT! When calibrating the humidity sensor, the calibration value is always displayed in % RH, even when absolute humidity control is selected for the unit. If absolute humidity control is selected, the Normal Status Display displays the adjusted reading, which may not agree with the relative humidity reading that displays in calibration.

To set sensor response time delay:

1. Press the *MENU* key.
2. Use the Up/Down arrows to highlight CALIBRATE SENSORS, then press *Enter*.
3. Use the Up/Down arrows to highlight a set delay option, then press *Enter*.
4. Use the Up/Down arrows to adjust the delay, then press *Enter* to store the value.

9.2.10 Enabling/Disabling Alarms

Many individual alarms may be enabled or disabled. When enabled, an alarm annunciates audibly, visibly, and communicates to a connected site monitoring system. When disabled, the alarm is completely ignored.

The alarms available for adjustment are:

- Custom Alarm #1
- Custom Alarm #2
- High Temperature
- Low Temperature
- High Humidity
- Low Humidity
- Short Cycle
- Loss of Power

To set enable or disable an alarm:

1. Press the *MENU* key.
2. Use the Up/Down arrows to highlight ALARM ENABLE, then press *Enter*.
3. Use the Up/Down arrows to highlight an alarm option, then press *Enter*.
4. Use the Up/Down arrows to enable/disable, then press *Enter* to store the value.

NOTE: When the alarm is disabled it will not report to the wall box or the common alarm relay.

NOTE: Even when the high water alarm is disabled, the unit automatically shuts off when a high water incident occurs. Also, the optional, factory installed smoke sensor automatically shuts off the evaporator unit when smoke is detected even if the alarm is disabled.

NOTE: The standard, factory installed high water alarm and high head pressure alarms cannot be disabled.

9.2.11 Setting Alarm Delays

For each alarm, you can set an amount of time to delay the notification after an alarm condition occurs. If the alarm condition resolves before the delay elapses, there is no alarm notification and the time delay resets automatically. The delay may be set for 0 to 255 seconds, in one second intervals. **Table 9.4** on the next page, lists each alarm and the default delay setting.

NOTE: Software alarms such as loss of power and short cycle, should be left at the factory default of 0.

Table 9.4 Default Alarm Delay Times

Alarm	Default Time Delay, seconds
Custom Alarm #1	0
Custom Alarm #2	6
High Temperature	30
Low Temperature	30
High Humidity	30

**Table 9.4 Default Alarm Delay Times
(continued)**

Alarm	Default Time Delay, seconds
Low Humidity	30
Short Cycle	0
Loss of Power	0

To set alarm delay times:

1. Press the *MENU* key.
2. Use the Up/Down arrows to highlight ALARM TIME DELAY, then press *Enter*.
3. Use the Up/Down arrows to highlight an alarm option, then press *Enter*.
4. Use the Up/Down arrows to select the delay, then press *Enter* to store the value.
5. Repeat steps 3 and 4 for each alarm delay to set.

NOTE: The delay for the standard, factory installed high head pressure alarm is not adjustable.

9.2.12 Activating the Common Alarm Relay

Each alarm can be set to activate the common alarm relay. The common alarm relay is K5. See [Enabling/Disabling Alarms](#) on the previous page, for the list of available alarms.

When set to YES (enabled), the relay energizes immediately when the alarm annunciates and de-energizes when the alarm is acknowledged. When set to NO (disabled), an alarm has no effect on the common alarm relay.

To set an alarm to trigger the common alarm relay:

1. Press the *MENU* key.
2. Use the Up/Down arrows to highlight COMMON ALARM ENABLE, then press *Enter*.
3. Use the Up/Down arrows to highlight an alarm option, then press *Enter*.
4. Use the Up/Down arrows to select YES/NO, then press *Enter* to store the value.
5. Repeat steps 3 and 4 for each common alarm to activate.

9.2.13 Configuring Custom Alarms

You can select custom alarm messages from a list of standard messages or you can create up to two custom text messages for selection. The following are the messages available for custom alarms:

- Filter Clog
- Humidifier Problem
- Water Flow Loss
- Loss of Air Flow
- Smoke Detected
- Custom Text #1 (See [Customizing Alarm Message Text](#) on the facing page. to create a custom message.)
- Custom Text #2 (See [Customizing Alarm Message Text](#) on the facing page. to create a custom message.)

To select the message for a custom alarm:

1. Press the *MENU* key.
2. Use the Up/Down arrows to highlight CUSTOM ALARMS, then press *Enter*.
3. Use the Up/Down arrows to highlight the alarm, then press *Enter*.
4. Use the Up/Down arrows to select the message, then press *Enter* to store the value.

9.2.14 Customizing Alarm Message Text

IMPORTANT! If using custom text messages, notify maintenance personnel of the alarm function and required action.

You can create custom messages for your custom alarms up to 20 characters in length including blank spaces or any of the following alphanumeric characters and symbols:

A, B, C, D, E, F, G, H, I, J, K, L, M, N, O, P, Q, R, S, T, U, V, W, X, Y, Z

#, %, *, -

0, 1, 2, 3, 4, 5, 6, 7, 8, 9

To create custom text message:

1. Press the *MENU* key.
2. Use the Up/Down arrows to highlight CUSTOM TEXT, then press *Enter*.
3. Use the Up/Down arrows to highlight the custom text option, then press *Enter*.
4. Use the Up/Down arrows to select the character, press *Enter* to store the value until the entire message is stored.
5. To use the custom message, select it from the CUSTOM ALARMS menu. See [Configuring Custom Alarms](#) on the previous page .

9.2.15 LCD Display Contrast

You can adjust the level of contrast to help with the viewing angle of the LCD display using a potentiometer screw inside the wall box next to the display.

9.2.16 Non-volatile Memory

All critical information is stored in non-volatile memory. Setpoints and setup parameters are kept inside the microcontroller in EEPROM.

9.2.17 Equipment Options DIP Switches

Equipment options are selected and enabled using a set of DIP switches mounted on the control board inside the ceiling mounted evaporator. The switches are factory set and should not be changed.

The switch settings on the control board are recognized by the microprocessor control and may be reviewed in the LCD display. **Table 9.5** on the next page , shows the setting options. See [SHOW DIPSWITCH](#) on page 60 , to review the settings on the display.

Figure 9.3 on page 69 shows the DIP switches on control board in the evaporator unit. **Figure 9.4** on page 70 shows the DIP switches on control board in the wall mounted controller.

NOTE: To update the DIP switch settings, power must be cycled Off, then On from the unit disconnect switch.

Table 9.5 Equipment Option DIP Switch Settings (on Unit Control Board)

Switch	OFF Position	ON Position
1	Compressor	Chill Water
2	Standard Reheat	SCR Reheat
3	No Modulating CW Valve	Modulating CW Valve
4	Not Used	Not Used
5	Enable Reheat	Disable Reheat
6	Enable Humidifier	Disable Humidifier
7	Enable Dehumidifier	Disable Dehumidifier
8	Electric Reheat	Gas Reheat

Table 9.6 DIP Switch Settings on Wall Box Board

Switch	OFF Position	ON Position
1	Beeper Disable	Beeper Enable
2	Not Used	Not Used
3	Not Used	Not Used
4	Not Used	Not Used
5	Not Used	Not Used
6	Not Used	Not Used
7	Disable Setback	Enable Setback
8	Enable Password	Disable Password

9.3 Running Diagnostics

Using the diagnostics tools, you can view system inputs and outputs and test the microcontroller without interrupting normal operation of the unit. Testing system outputs temporarily suspends normal system control and operation.

9.3.1 Showing Test Inputs

You can view the input state of the devices listed in **Table 9.7** on the facing page, with the unit on and the fan running.

To show the test inputs:

1. Press the *MENU* key.
2. Use the Up/Down arrows to highlight **DIAGNOSTICS**, then press *Enter*.
3. Use the Up/Down arrows to highlight **TEST INPUTS**, then press *Enter*.
4. Use the Up/Down arrows to scroll through the inputs list.

Table 9.7 Test Inputs

Input Circuit	Normal Status
High Water Alarm	Off unless High Water Alarm is active.
High Head Pressure Alarm	Off unless High Head Pressure Alarm is active.
Custom alarm #1	Off unless this special customer selectable alarm is active.
Custom alarm #2	Off unless this special customer selectable alarm is active.
Power	On unless unit is turned off through the wall box or any of the following optional devices: high temperature sensor, High Water Alarm or Remote Shutdown.

9.3.2 Testing Outputs

NOTICE

Risk of overheating the compressor during the Test Output mode. Testing the compressor output for more than a few seconds can cause compressor damage.

Extended unit operation in the Test Outputs mode may damage the unit. Do not operate the unit in the Test Outputs mode any longer than is necessary for troubleshooting.

NOTICE

Risk of extended unit operation in the test outputs mode for troubleshooting. Can cause damage to the unit.

Do not operate unit in the test outputs mode any longer than is necessary for troubleshooting.

The outputs available are:

- Normal fan: normal speed fan contactor
- Low Speed Fan: low speed fan contactor (on direct drive blower units only)
- Humidifier: steam humidifier contact (if present)
- Cool: compressor contactor or chilled water valve
- HGBP: hot gas bypass valve
- Reheat: reheat contactor (if present)
- Common Alarm: common alarm relay

When testing outputs, the unit is effectively turned off. When stepping from one load to the next, the previous load is automatically turned off if it was on.

NOTE: Compressor is limited to 15 seconds On to prevent damage.

NOTE: When testing outputs, the fan is turned On with all loads. After six minutes without user input, the controller automatically exits test output mode and returns to normal operation.

To test the outputs:

1. Press the *MENU* key.
2. Use the Up/Down arrows to highlight *DIAGNOSTICS*, then press *Enter*.
3. Use the Up/Down arrows to highlight *TEST OUTPUTS*, then press *Enter*.
4. Use the Up/Down arrows to highlight the output to test, the press *Enter* to toggle the load on/off.
The output remains for five minutes unless toggled Off, when you step to the next load, or when you exit the test outputs function.

9.3.3 Testing the Microcontroller

When selected, the microcontroller performs a self test that lasts approximately 10 seconds. When the test is complete, the display shows the ROM checksum, ROM part number, and the firmware revision number.

To test the microcontroller:

1. Press the *MENU* key.
2. Use the Up/Down arrows to highlight *DIAGNOSTICS*, then press *Enter*.
3. Use the Up/Down arrows to highlight *TEST MICROCONTROLLER*, then press *Enter*.

Figure 9.3 on the facing page , shows the control board in the evaporator unit. **Figure 9.4** on page 70 , shows the connections on control board in the wall mounted controller.

Figure 9.3 Control Board Inside the Evaporator

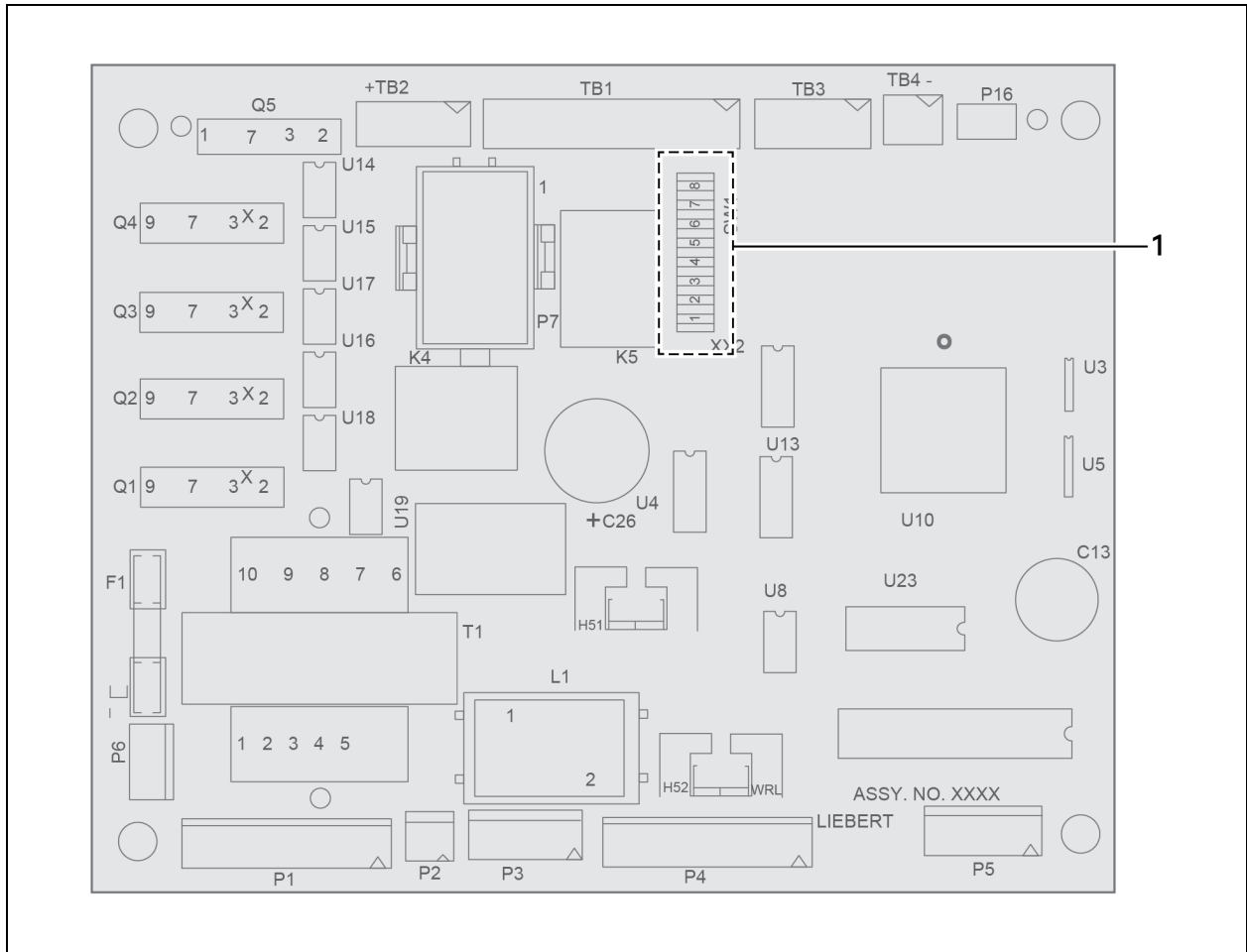

Item	Description
1	DIP switches 1 – 8

Table 9.8 Connections/Functions of Control Board Inside Evaporator

Connection	Function	Connection	Function
TB2-4	Hot Gas Bypass	TB1-2	Customer Alarm Connection #1
TB2-3	High Head Alarm Connection	TB1-1	Customer Alarm Connection (Common)
TB2-2	Heat Rejection (24 VAC+)	TB3-4	Connection to Terminal #4 Wall Box
TB2-1	Heat Rejection (24 VAC GND)	TB3-3	Connection to Terminal #3 Wall Box
TB1-9	Condensate Pump Aux Alarm	TB3-2	Connection to Terminal #2 Wall Box
TB1-8	Condensate Pump Aux Alarm	TB3-1	Connection to Terminal #1 Wall Box
TB1-7	Common Alarm Connection	TB4-2	Site Monitoring Connection (-)
TB1-6	Common Alarm Connection	TB4-1	Site Monitoring Connection (+)

Table 9.8 Connections/Functions of Control Board Inside Evaporator (continued)

Connection	Function	Connection	Function
TB1-5	Remote Shutdown	P16	Remote Sensor Connection
TB1-4	Remote Shutdown		
TB1-3	Customer Alarm Connection #2		

Figure 9.4 Control Board Inside the Wall Mounted Controller

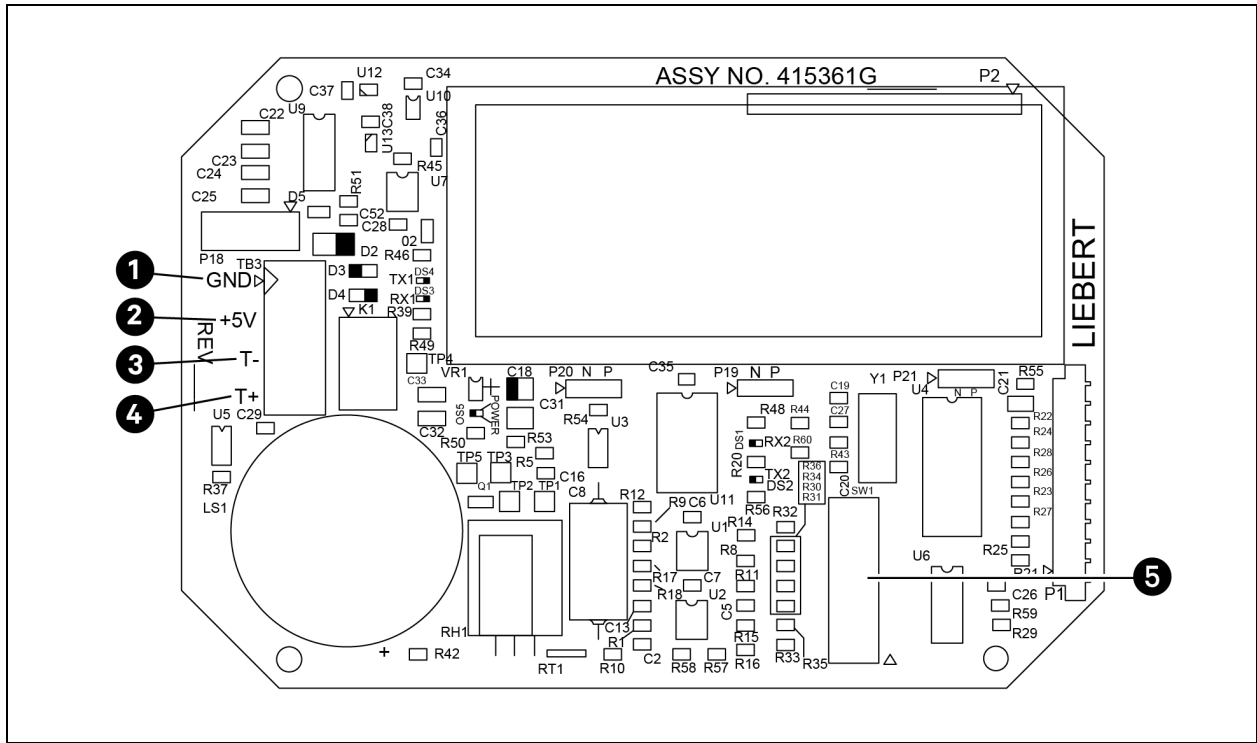

Item	Description
1	TB3-1
2	TB3-2
3	TB3-3
4	TB3-4
5	DIP switches 1 to 8

9.4 System Control and Performance

This section describes how the Vertiv™ Liebert® Mini-Mate2 responds to operator input and room conditions.

9.4.1 Temperature Control

The following describes the methods of temperature control and determining cooling requirement for the various Liebert® Mini-Mate2 cooling types.

Control Type Response Proportional Control

The percent requirement for temperature control is determined by the difference between the return air temperature and the temperature setpoint. As the return air temperature rises above the temperature setpoint, the percent cooling required increases proportionally (from 0 to 100%) over a temperature band equal to the temperature sensitivity plus 1°F. The heating requirement is determined in a similar manner as the temperature decreases below the setpoint. With this control type, the temperature at which the room is controlled increases as the room load increases. At full load, the room is controlled to a temperature equal to the setpoint plus the sensitivity.

Cooling Operation for Compressorized (DX) Systems

Cooling is activated when the temperature control calculates a cooling requirement of 100% and deactivated when the cooling requirement drops below 50%. Hot gas bypass is activated when a call for cooling occurs unless there is also a call for dehumidification.

Table 9.9 Hot Gas Bypass Response to Cooling and Dehumidification Modes

Mode	Hot-gas bypass
Cooling only	ON
Dehumidification only	OFF
Cooling with Dehumidification	OFF

Cooling Operation for Chilled Water Systems

The chilled water control valve is adjusted by a slow acting motor based on cooling and dehumidification requirements.

Cooling Operation for DX Systems with Free Cooling Coil

When free cooling is available, the free cooling control valve is adjusted by a slow acting motor based on cooling and dehumidification requirements.

9.4.2 Reheat

The following describes the methods of reheat control and determining reheat requirement for the various Liebert® Mini-Mate2 cooling types.

Ground Current Detector

A Ground Current Detector (GCD) is factory installed on all units with reheat. The GCD detects reheat leakage current and shuts-down operation of the reheat. A steady green LED indicates that the reheat is operating properly. A red LED indicates that the reheat has failed and both the reheat element and GCD must be replaced.

! WARNING! Risk of ground fault protection failure. Can cause smoke, fire, equipment, and building damage, injury, or death. Do not remove or disable the ground current detector.

Figure 9.5 Ground Current Detector

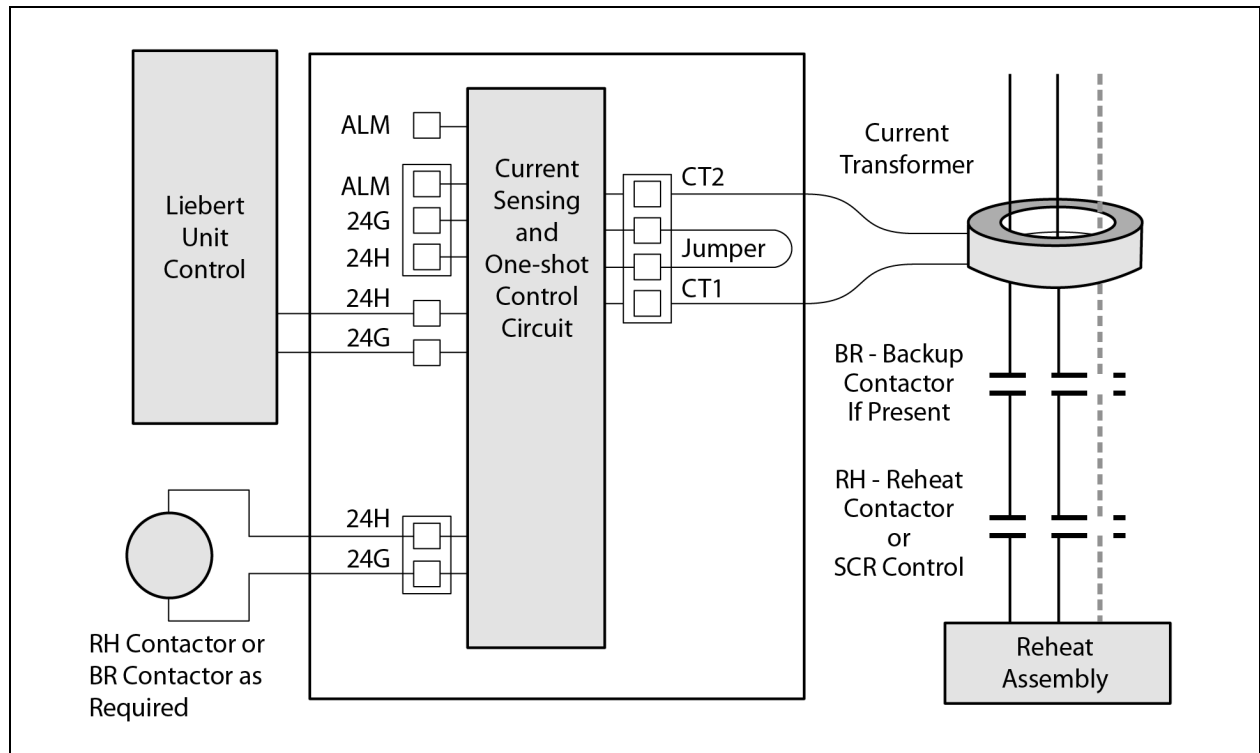

Electric or Hot Water Reheat

The reheat stage activates when the temperature control calculates a requirement of 100%. The reheat is deactivated when the heat requirement is 50% less than the activation point.

SCR Electric Reheat

The SCR proportionally controls the stainless steel reheat feature to maintain the selected room temperature. The rapid cycling of the SCR controller provides precise temperature control, while the constant element temperature improves heater life. During SCR operation, the compressors operate continuously and the heaters are modulated to provide temperature control.

The display status shows when the unit is cooling and heating. The control automatically locks the compressor cooling in the ON position except when the temperature falls below the low temperature alarm setpoint. When temperature falls below the low temperature setpoint, cooling is disabled until the room temperature reaches this minimum temperature setpoint.

9.4.3 Humidity Control

The following describes the methods of humidity control and determining humidification/dehumidification requirement for the various Vertiv™ Liebert® Mini-Mate2 cooling types.

Humidification Operation

The humidifier activates when the humidity control calculates a 100% humidification requirement, and it is deactivated when the humidification requirement falls below 50%.

Dehumidification/Humidification Percent Required

The humidity control for the Liebert® Mini-Mate2 is based on a calculated percent requirement for dehumidification or humidification. The percent requirement is calculated from the difference between the sensor reading and the humidity setpoint, divided by the sensitivity. The control method is selectable between relative and absolute. Relative humidity control is the default.

Dehumidification Operation for Compressorized (DX) Systems

Dehumidification in the standard configuration operates the compressor without the hot gas bypass active. The fan operates at low speed unless the cooling requirement reaches 100%. At 100% cooling requirement, the low speed fan is disabled (unless manually overridden) until the cooling requirement decreases to 0%. Dehumidification is also disabled if the heating requirement exceeds 125% and is re-enabled when the heating requirement reaches 50%.

Dehumidification Lockout

Dehumidification is locked out if over cooling occurs. Dehumidification is disabled at 125% (first stage) and 200% (all stages) heating requirement. Dehumidification is re-enabled at 66% and 33% heating requirement.

9.4.4 Load Control

The control system monitors the compressor and prevents it from turning on within a three-minute period of being off. If this on-off-on cycle occurs too often (for example: 10 times in a one-hour period), a Short Cycle Alarm occurs.

9.4.5 Monitoring

IS-UNITY-DP BMS Monitoring Solution - Factory Installed

The IS-UNITY-DP card is a factory installed option, providing full building management system (BMS) access via BACnet/Modbus IP and BACnet/Modbus 485. Card provides access and supports SNMP v1/v2c/v3 and Vertiv™ Liebert® Nform. The card is factory installed in a unit mounted external enclosure and is factory wired for communication to and powered from the Liebert® Mini-Mate2 unit. Field wiring to other systems required to access features.

IS-UNITY-DP BMS Monitoring Solution - Field Installed

The IS-UNITY-DP card provides full building management system (BMS) access via BACnet/Modbus IP and BACnet/Modbus 485. Card provides access and supports SNMP v1/v2c/v3 and Vertiv™ Liebert® Nform.

- The unit mount kit for field installation includes the IS-UNITY-DP card, power/communication interface card, enclosure, all required power and communication wires to the Liebert® Mini-Mate2 unit, and full instructions. Field supplied wiring to other systems required to access features.
- The wall mount kit for field installation includes the IS-UNITY-DP card, power/communication interface card, painted enclosure, 120-V wall outlet transformer with 6-foot (2-m) low voltage power wire, and full instructions. Field supplied wiring for communication to Vertiv™ Liebert® Mini-Mate2 and to other systems is required to access features.

9.5 Alarm Notification, Acknowledgment, and Descriptions

The microprocessor control system audibly and visually signals all enabled alarms including custom alarms. See [Configuring Custom Alarms](#) on page 64 , for settings and customization options.

When a new alarm occurs, it is displayed on the screen and the audible alarm is activated. (If communicating with a Liebert monitoring product, the alarm is also transmitted). The message PRESS ALARM SILENCE prompts you to silence the alarm. After the alarm is silenced, the display returns to the Normal Status display. Alarms can also be silenced through communication with a Liebert monitoring product unit. See [Viewing Active Alarms](#) on page 58 .

Many alarms reset automatically when the alarm condition is no longer represented and after it has been acknowledged by being silenced. The exceptions are:

- Software alarms—Loss of Power alarms reset automatically 30 seconds after being silenced or acknowledged. Short Cycle alarms reset automatically 90 minutes after being silenced or acknowledged.
- Alarms that monitor overload or high pressure switches may require a manual reset depending upon the model.

The following sections describe and provide troubleshooting suggestions for each type of alarm. See [Troubleshooting](#) on page 99 for additional details. If you need further assistance, contact your Vertiv representative.

NOTE: Alarms are specific at the time the unit is ordered. Additional devices and wiring at the factory may be required for some alarms.

9.5.1 Custom Alarms

Custom alarm(s) messages are programmed at the LCD display. The message displayed may be included in a list of provided alarms or it may be customized text (for up to two alarms). See [Configuring Custom Alarms](#) on page 64 .

IMPORTANT! If using custom text messages, notify maintenance personnel of the alarm function and required action.

9.5.2 High Head Pressure Alarm

Compressor head pressure is monitored with a pressure sensor switch. (One SPDT pressure switch is used per refrigeration circuit). If head pressure exceeds 400 psig (2,760 kPag), the switch turns off the compressor contactor and sends an input signal to the control.

Acknowledge the condition by pressing the alarm silence button on the wall box, which will clear if the high head pressure is alleviated.

If the head pressure alarm activates three times, the alarm locks until the unit is serviced. After the head pressure problem is fixed, reset the control by disconnecting power to the evaporator unit.

To address a high head pressure alarm:

- On air cooled systems—check for power shut off to the condensing unit, condensing unit fan not working, defective head pressure control valves, dirty condenser coils or crimped lines. Also, make sure that side switch on the compressor contactors close to energize the condensing unit control circuit.
- On water/glycol cooled systems—Check water regulating valves. Verify water/glycol flow (pumps are operating and service valves are open). Is water tower or drycooler operating? Is the coolant temperature entering the condensing unit at or below design conditions? Is AUX relay (terminals 70 & 71) operating during cooling to turn on the drycooler?

9.5.3 Humidity Level Alarms

The humidity alarm may be activated under the following conditions:

- High: The room return air humidity exceeds the preset high humidity alarm setpoint. Is the unit set up for dehumidification? Check DIP switch.
- Low: The room return air humidity is below the low humidity alarm setpoint. Is the unit set up for humidification? Check DIP switch.
- High and Low Humidity (simultaneously): The simultaneous display of two alarms results in loss of the humidity input signal, and dashes (- - -) are displayed for the humidity reading on the display. If this condition occurs, the control system deactivates both humidification and dehumidification. Check for a disconnected cable or failed sensor.

NOTE: Check for proper setpoints. Does the room have a vapor barrier to seal it from outdoor humidity? Are doors or windows open to outside air?

9.5.4 Temperature Level Alarms

The temperature level alarm may be activated under the following conditions:

- High: Room return air temperature increases to the high temperature alarm setpoint. Check for proper setpoint value. Is the room load more than the unit can handle (unit capacity is too small)? Make sure cooling components are operating (compressor or valves).
- Low: The room return air temperature decreases to the low temperature alarm setpoint. Check for proper setpoint value. Make sure all heating components are operating (contactors, reheats, etc.). Are reheats drawing the proper current (refer to amp rating on nameplate)?
- High and Low Simultaneously: The simultaneous display of the two alarms results in loss of the temperature input signal (or the humidity is out of sensor range-15 to 85% RH), and dashes (---) are displayed for the temperature reading on the display. If this condition occurs, the control system initiates 100% cooling. Check for a disconnected cable or a failed sensor.

NOTE: Check for proper setpoints. Does the room have a vapor barrier to seal it from outdoor humidity? Are doors or windows open to outside air?

9.5.5 Humidifier Problem Alarm

The Humidifier Problem alarm sounds and displays a message if any of the humidifier conditions described in **Table 9.10** below, occur. The Humidifier's control board fault indicator LED assists in determining the issue.

Table 9.10 Humidifier Faults and LED Indicator

Fault Condition	LED Indicator
Overcurrent detection	Lit constant
Fill system fault	1-second flash
Replace tank	1/2-second flash

9.5.6 High Water Alarm

A float switch in the evaporator pan shuts down the evaporator when a high water level occurs. Clear the drain and reset power to the unit to clear the alarm.

9.5.7 Loss of Power Alarm

The Loss of Power alarm activates (after power is restored to the unit) if the unit has lost power or the disconnect switch was incorrectly turned off before the unit's On switch was pressed. A Liebert remote monitoring unit (optional) will immediately indicate loss of power.

9.5.8 Short Cycle Alarm

A Short Cycle alarm occurs if the compressor system exceeds 10 cooling start attempts in a one-hour period. This may happen if the refrigerant level is low or if the cooling load is small compared to the unit's capacity. Check for leaks, crimped lines, and defective components. If the cooling load is low, increase sensitivity to reduce cycle.

9.5.9 Loss of Water Flow Alarm

NOTE: This alarm may not be available depending on cooling type, unit options, and alarm customization.

The Loss of Water Flow alarm occurs if no water flow is detected in the chilled water or condensing unit water supply line. An external flow switch is required for this alarm. Determine whether service valves are closed, pumps are not working, etc.

9.5.10 Change Filter Alarm

NOTE: This alarm may not be available depending on cooling type and alarm customization.

Periodically, the return air filters in the evaporator must be changed. The Change Filter alarm indicates that filter replacement is necessary. A differential air pressure switch closes when the pressure drop across the filters becomes excessive. The switch is adjustable using the procedure on the switch label.

9.5.11 High Temperature Alarm

NOTE: This alarm may not be available depending on cooling type and alarm customization.

The high temperature alarm occurs when the temperature exceeds high temperature sensor setpoint of 125°F (52°C). The optional high temperature sensor is a bi-metal operated sensing device with a closed switch under normal conditions. Connected between pins 1-8 and 1-9, this device shuts down the entire unit.

9.5.12 Smoke Alarm

NOTE: This alarm may not be available depending on cooling type, unit options, and alarm customization.

The smoke alarm occurs when the smoke sensor detects smoke. The sensor constantly samples return air through a tube. The sensor's power supply is located in the electric panel. The smoke sensor shuts down the unit upon detecting smoke, and activates visual and audible alarms. This smoke sensor is not intended to function as or replace any room smoke detection system that may be required by local or national codes. Locate the source of the smoke and follow appropriate emergency procedures.

This page intentionally left blank

10 Maintenance

Use copies of the [Preventive Maintenance Checklist](#) on page 93 to record preventive maintenance inspections.



WARNING! Arc flash and electric shock hazard. Open all local and remote electric power supply disconnect switches, verify with a voltmeter that power is Off and wear appropriate, OSHA approved personal protective equipment (PPE) per NFPA 70E before working within the electric control enclosure. Failure to comply can cause serious injury or death. Customer must provide earth ground to unit, per NEC, CEC and local codes, as applicable. Before proceeding with installation, read all instructions, verify that all the parts are included and check the nameplate to be sure the voltage matches available utility power. The Vertiv™ Liebert® iCOM™ controller does not isolate power from the unit, even in the Unit Off mode. Some internal components require and receive power even during the Unit Off mode of the controller. The only way to ensure that there is NO voltage inside the unit is to install and open a remote disconnect switch. Refer to unit electrical schematic. Follow all local codes.



WARNING! Risk of electric shock. Can cause equipment damage, injury, or death. Open all local and remote electric power supply disconnect switches and verify with a voltmeter that power is off before working within any electric connection enclosures. Service and maintenance work must be performed only by properly trained and qualified personnel and in accordance with applicable regulations and manufacturers' specifications. Opening or removing the covers to any equipment may expose personnel to lethal voltages within the unit even when it is apparently not operating and the input wiring is disconnected from the electrical source.



WARNING! Risk of improper wiring, piping, moving, lifting, and handling. Can cause equipment damage, serious injury, or death. Installation and service of this equipment should be done only by qualified personnel, wearing appropriate, OSHA approved PPE, who have been specially trained in the installation of air conditioning equipment.

The Vertiv™ Liebert® Mini-Mate2 units are single components in the facility heat removal system. The system includes air distribution (duct systems), heat rejection (condensing units or chilled water), and indoor cooling and humidity loads (equipment load, location, outside air infiltration). Proper application and maintenance of the entire system is critical to the life and reliability of the thermal management units.

- Good maintenance practices are essential to minimizing operation costs and maximizing product life.
- Read and follow monthly and semi-annual maintenance schedules included in this manual. These MINIMUM maintenance intervals may need to be more frequent based on site specific conditions.
- We recommend the use of trained and authorized service personnel, extended service contracts and factory specified replacement parts. Contact your Vertiv sales representative.

10.1 System Testing



WARNING! Arc flash and electric shock hazard. Open all local and remote electric power supply disconnect switches, verify with a voltmeter that power is Off and wear appropriate, OSHA approved personal protective equipment (PPE) per NFPA 70E before working within the electric control enclosure. Failure to comply can cause serious injury or death. Customer must provide earth ground to unit, per NEC, CEC and local codes, as applicable. Before proceeding with installation, read all instructions, verify that all the parts are included and check the nameplate to be sure the voltage matches available utility power. The Liebert® controller does not isolate power from the unit, even in the Unit Off mode. Some internal components require and receive power even during the Unit Off mode of the controller. The only way to ensure that there is NO voltage inside the unit is to install and open a remote disconnect switch. Refer to unit electrical schematic. Follow all local codes.



WARNING! Risk of contact with high-speed moving parts. Can cause injury or death. Open all local and remote electric power-supply disconnect switches, verify with a voltmeter that power is off, and verify that all the fan blades have stopped moving before working in the unit.

10.1.1 Environmental Control Function Tests

The performance of all control circuits can be tested by changing the setpoints, which actuates each of the main functions.

10.1.2 Cooling Test

To test the cooling function, set the setpoint to a temperature of 10°F (5°C) below room temperature. A call for cooling should register and prompt the equipment to begin cooling cycle. (Disregard any temperature alarms.) Upon completion of testing, return the setpoint to the desired temperature.

10.1.3 Heating Test

Test Reheat by setting the setpoint to 10°F (5°C) above room temperature. A call for heating should register and prompt the equipment to begin heating cycle. (Disregard any temperature alarms.) Upon completion of testing, return the setpoint to the desired temperature.

10.1.4 Humidification Test

To check humidification, set the humidity setpoint at 10% RH above the room humidity reading. After a short delay, the canister will fill with water and steam will be produced. Upon completion of testing, return the humidity setpoint to the desired humidity.

10.1.5 Dehumidification Test

Test dehumidification by setting the humidity setpoint at 10% RH below room relative humidity. The compressor should turn on. Upon completion of testing, return the humidity setpoint to the desired humidity.

10.1.6 Smoke Sensor Test

The smoke sensor is located in the unit and the power supply for the smoke sensor is located in the electric panel. It constantly samples return air through a tube. No adjustments are required.

10.1.7 Remote Shutdown Test

A connection point is provided for remote shutdown devices supplied by the customer. This terminal strip is on the printed circuit board. (Terminals TB1-4 and TB1-5 are fitted with a jumper when no remote shutdown device is installed.)

10.2 Filter Maintenance

Experience shows that filters are usually the most neglected item in an environmental control system. In order to maintain efficient operation, they should be checked monthly and changed as required.

NOTE: Always turn power Off before removing filters.

Filters can be replaced by opening the hinged door on the return air filter box. Replacement filters are commercially available in several efficiencies. Contact your Vertiv representative for appropriate filter sizes.

10.3 Electric Panel Maintenance

Inspect the electric panel on a semi-annual basis for any loose electrical connections.

10.4 Belt Drive Blower Package Maintenance

Inspect the blower package monthly including: motor mounts, belts, fan bearings, and impellers.

10.4.1 Fan Impeller and Motor Bearing Maintenance

Inspect fan impellers thoroughly and remove any debris. Check to see if the impellers are tightly mounted on the fan shaft and that they do not rub against the fan housing during rotation. Although the unit's motor bearings are permanently sealed and self-lubricating, inspect them monthly for signs of wear.

10.4.2 Air Distribution Inspection

Because all unit models are designed for constant volume air delivery, any unusual restrictions within the air circuit must be avoided. Note that high efficiency filters can reduce air performance and evaporator capacity.

10.4.3 Motor Replacement

If the evaporator motor needs to be replaced, first remove the air distribution plate on the bottom of the unit. Removing the mounting screws, allows the entire blower wheel, and motor to be lifted out.

10.4.4 Removing the Blower from the Evaporator

You may need to remove the blower for servicing/replacement or to access the bearings for service.

NOTICE

Risk of refrigerant and water/glycol piping damage. Can cause leaks that result in equipment and building damage and loss of cooling.

Use caution and do not contact piping when removing the blower motor and blower sled.

To remove the belt drive blower:

1. Prepare the main center section of the 3-piece electric panel by marking and disconnecting all power and control wiring entering the panel.
2. Remove the main center section of the panel by removing screws from top and bottom sections.
3. Remove the blower motor from the blower sled.
4. Remove the four bolts holding the blower sled to the base isolators.
5. Slide the blower/sled assembly forward and rotate 90 degrees.
6. Slide the blower/sled assembly from unit after ensuring that the refrigerant and water piping are protected from damage.
7. Reinstall by reversing this procedure.

10.5 Electric Reheat Maintenance

Reheat element sheets and fins are manufactured with stainless steel. Regular inspections are necessary to assure proper cleanliness of the reheating element. If inspection reveals corrosion particles on the reheating element or adjoining surfaces (including ducts and plenums), perform appropriate cleaning. Periodic replacement of the reheating element may be necessary to meet specific application requirements.

10.6 Refrigeration System Maintenance

Inspect the components of the refrigeration system monthly for proper function and signs of wear. Because evidence of malfunction is typically present before component failure, periodic inspections are major factor in the prevention of most system failures. Refrigerant lines must be properly supported and not allowed to vibrate against ceilings, floors, or unit frame. Inspect all refrigerant lines every 6 months for signs of wear and proper support. Inspect the capillary and equalizer lines from the expansion valve.

10.6.1 Refrigeration Suction Pressure

Suction pressure will vary with load conditions. Suction pressure normally ranges from 58 psi to 75 psi (405 kPa to 517 kPa).

10.6.2 Refrigeration Discharge Pressure

The discharge pressure will vary greatly with load and ambient conditions, see **Table 10.1** on the facing page. The high pressure switch shuts down the compressor at its cut-out setting.

Table 10.1 Typical Discharge Pressures

System Design	Discharge Pressure, psig (kPa)
Air Cooled	200-300 (1,380-2,070)
Water Cooled 65 to 85°F water (18 to 29.4°C)	200-250 (1,380-1,725)
Glycol Cooled	250-350 (1,725-2,415)
High Pressure Cut-Out	400 (2,760)

10.6.3 Thermostatic Expansion Valve (TXV) Maintenance

The TXV performs one function: It keeps the evaporator supplied with enough refrigerant to satisfy load conditions. It does not affect compressor operation.

Proper valve operation can be determined by measuring superheat. The correct superheat setting is between 10 and 15°F (5.6 and 8.3°C). If too little refrigerant is being fed to the evaporator, the superheat will be high. If too much refrigerant is being supplied, the superheat will be low.

10.6.4 Air Cooled Condensing Unit Maintenance

Restricted airflow will reduce operating efficiency and could result in high compressor head pressure and loss of cooling.

- Clear coil surface of all debris that will inhibit airflow.
- Check for bent or damaged coil fins and correct.
- Do not permit snow to accumulate around or under outdoor unit.
- Periodically consider commercial cleaning of coil surface.
- Inspect fans, motors, and controls for proper operation.
- Check all piping and capillaries for vibration and proper support.
- Inspect all refrigerant lines for signs of oil leaks.
- Check contactors for pitting. Replace if pitted.

10.6.5 Hot Gas Bypass Operation and Maintenance

When applying hot gas bypass with split system condensing units, bypassing discharge gas to the compressor suction line offers more flexibility than conventional hot gas bypass to the evaporator unit.

The hot gas bypass valve is installed between the compressor discharge piping and suction piping, bypassing the condenser and evaporator coils. The discharge gas mixes with the suction gas, raising the suction temperature and pressure and decreasing the mass flow through the evaporator. The higher suction temperatures could cause compressor overheating, therefore a separate, liquid quenching valve is provided to mix refrigerant from the system liquid line with the discharge gas before mixing with the suction gas entering the compressor.

During normal operation, when the evaporator is under full load, the hot gas bypass equalizer pressure will remain high enough to keep the valve port closed. If the evaporator load decreases, the evaporator temperature and pressure will drop. When the suction pressure reduces below the hot gas bypass valve setting, the hot gas bypass valve opens diverting some of the refrigerant flow back to the compressor suction. The liquid quenching valve bulb senses this increased superheat and opens, allowing liquid refrigerant to mix with the discharge gas, de-superheating it.

Proper mixing of the three refrigerant paths ensures stable operation and system performance. The liquid quenching valve bulb must be located downstream of all these connections to control superheat at the compressor inlet. Superheat settings for the liquid quenching valve are chosen to maintain consistency with the system expansion valve. During hot gas bypass operation, higher superheats, 50 to 60°F (28 to 33°C), may be observed at the compressor. The liquid quenching valve is internally equalized and superheat is not adjustable.

Figure 10.1 Hot Gas Bypass Components and Flow

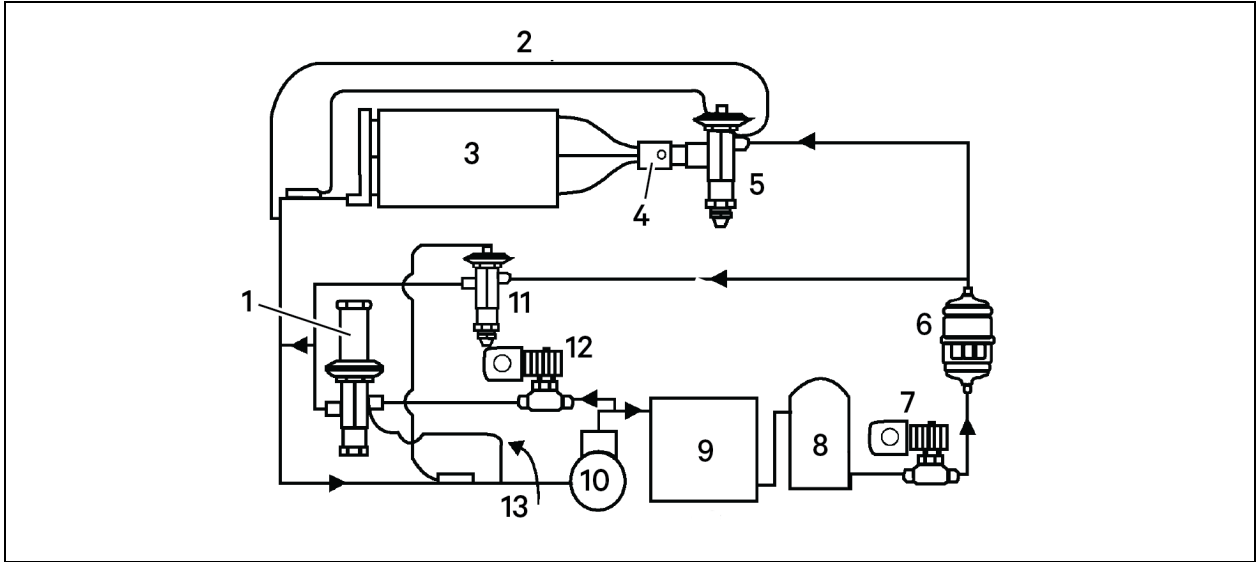

Item	Description
1	Discharge bypass valve
2	External equalizer
3	Evaporator
4	Distributor
5	TEV
6	Catch-all
7	Solenoid valve
8	Receiver
9	Condenser coil
10	Compressor
11	De-superheating TEV
12	Hot gas solenoid valve
13	External equalizers

To adjust hot gas bypass:

1. Install the suction and discharge pressure gauge.
2. Adjust temperature setpoint to call for cooling so that the refrigeration compressor will run continuously.
3. Remove the TOP adjusting nut from the valve.

4. Insert an Allen wrench in the brass hole at top of valve in adjusting port, and turn CLOCKWISE if a higher evaporator temperature is required. Adjust no more than 1/4 turn at a time. Let the system stabilize for 15 minutes before determining if additional adjustment are necessary.
5. After obtaining the suction pressure required, reinstall cap tightly making sure there are no leaks.
6. Let the evaporator operate for approximately 10 to 15 minutes to make sure the suction pressure is within the range desired.
7. There may be a fluctuation of approximately 3 to 6 psig (21 to 41 kPa) on the evaporator due to the differential on the hot gas bypass.
8. Return temperature setpoint to the desired setting.

10.6.6 Coaxial Condenser Maintenance (Water/Glycol Cooled Condensers Only)

Each water or glycol cooled module has a coaxial condenser consisting of an exterior steel tube and an interior copper tube. Clean the screen on the field-installed Y-strainer (if installed). If the water supply is clean, coaxial condensers do not normally require maintenance or replacement. If your system begins to operate at high head pressure with reduced capacity and all other causes have been eliminated, the condenser may be obstructed or fouled and should be cleaned or replaced.

10.6.7 Regulating Valve Maintenance (Water/Glycol-cooled Condensers Only)

The water regulating valve automatically regulates the amount of fluid necessary to remove the heat from the refrigeration system, permitting more fluid to flow when load conditions are high and less fluid to flow when load conditions are low. The valve consists of a brass body, balance spring, valve seat, valve disc holders, capillary tube to discharge pressure, and adjusting screw.

The water regulating valve begins opening at 180 psig (1240 kPag) and is fully opened at 240 psig (1,655 kPag). The valve is factory set and should not need adjustment. There is significant difference in the way standard pressure and high pressure valves are adjusted. Consult Vertiv technical support.

10.6.8 Glycol Solution Maintenance

It is difficult to establish a specific schedule of inhibitor maintenance because the rate of inhibitor depletion depends upon local water conditions. Analysis of water samples at the time of installation and through a maintenance program should help to establish a pattern of depletion. A visual inspection of the solution and filter residue is often helpful in judging whether active corrosion is occurring.

The complexity of water/glycol solution condition problems and the variations of required treatment programs make it extremely important to obtain the advice of a competent and experienced water treatment specialist and follow a regularly scheduled coolant fluid system maintenance program. It is important to note that improper use of water treatment chemicals can cause problems more serious than using none. Proper inhibitor maintenance must be performed in order to prevent corrosion of the glycol system. Consult the glycol manufacturer for testing and maintenance of inhibitors. Do not mix products from different manufacturers.

10.7 Compressor Maintenance



WARNING! Risk of over-pressurization of the refrigeration system. Can cause piping rupture, explosive discharge of high pressure refrigerant, loss of refrigerant, environmental pollution, equipment damage, injury, or death. This unit contains fluids and gases under high pressure. Use extreme caution when charging the refrigerant system. Do not pressurize the system higher than the design pressure marked on the unit's nameplate. Relieve pressure before cutting into or making connections/disconnections to the piping system. Local building or plumbing codes may require installing a pressure relief device in the system.

Consult local building and plumbing codes for installation requirements of additional pressure relief devices when isolation valves are field installed. Do not isolate any refrigerant circuits from over-pressurization protection. The PFH condensing units include a factory installed pressure relief valve mounted on top of the receiver. The valve is rated for a maximum working pressure of 475 psig.



CAUTION: Risk of contacting caustic substances. Can cause injury. Avoid touching or contacting the gas and oils with exposed skin. Severe burns will result. Wear appropriate, OSHA approved PPE when handling contaminated parts.

Infrequently, a fault in the motor insulation may result in a motor burnout (if system is properly installed, motor burnout rarely occurs). Primarily, this type of failure is due to mechanical or lubrication problems, where the burnout is a secondary consequence.

Early detection can prevent a large percentage of the problems that can cause compressor failures. Periodic maintenance inspections that identify abnormal operation can be a major factor in reducing maintenance costs. It is easier and more cost-effective to implement the necessary preventative steps that ensure proper system operation, rather than ignore a problem until it results in compressor failure and costly replacement. When troubleshooting a compressor problem, check all electrical components for proper operation:

- Check all fuses and circuit breakers.
- Check pressure switch operation.
- If a compressor failure has occurred, determine whether its cause is an electrical or mechanical problem.

10.7.1 Mechanical Failure of the Compressor

If you determine that a mechanical failure has occurred, the compressor must be replaced. If a burnout occurs, correct the problem and clean the system. It is important to note that successive burnouts of the same system are usually caused by improper cleaning. If a severe burnout has occurred, the oil will be black and acidic.

10.7.2 Electrical Failure of the Compressor

In the event of an electrical failure and subsequent burnout of the refrigeration compressor motor, proper procedures must be followed to thoroughly remove any acids that would cause a future failure. There are two kits that can be used with a complete compressor burnout - Sporlan System Cleaner and Alco Dri-Kleener. Follow the manufacturer's procedure.

NOTE: Damage to a replacement compressor due to improper system cleaning constitutes abuse under the terms of the warranty, thereby voiding the warranty.

10.7.3 Replacement Compressors

Replacement compressors are available from your Vertiv supplier and are shipped to the job site in a reusable crate (as required by the service contractor). If the compressor is under warranty, you must return it to Vertiv™, to receive proper warranty credit. Returned it in the same container in which the replacement compressor was shipped. Record the possible cause(s) or condition(s) of the damage on the provided return tag.

10.7.4 Replacing a Failed Compressor

1. Disconnect power.
2. Attach suction and discharge gauges to access fittings.
3. Recover refrigerant using standard recovery procedures and equipment. Use a filter drier when charging the system with recovered refrigerant.

NOTE: Release of refrigerant to the atmosphere is harmful to the environment and unlawful. Refrigerant must be recycled or discarded in accordance with federal, state, and local regulations.

4. Remove failed compressor.
5. Install replacement compressor and make all connections.
 - Use a flow of dry nitrogen through the piping during brazing to prevent formation of copper oxide scale inside the piping. Copper oxide forms when copper is heated in the presence of air. POE oil will dissolve these oxides from inside the copper pipes and deposit them throughout the system, clogging filter driers and affecting other system components.
 - A pure dry nitrogen flow of 1-3 ft³/min (0.5-1.5 l/s) inside the pipe during brazing is sufficient to displace the air. Control the flow using a suitable metering device. Pressurize and leak test the system at approximately 150 psig (1,034 kPa) pressure.
6. Follow manufacturer's instructions for clean-out kits.
7. Evacuate the system twice to 500 microns. Break the vacuum each time with clean, dry nitrogen.
8. Evacuate the system a third time to 500 microns.
9. Charge the system with refrigerant (R-407C) based on requirements of the evaporator, condensing unit, and lines. Refer to the unit nameplate.
10. Apply power and operate the system. Check for proper operation. Refer to **Table 10.1** on page 83.

10.8 Steam Generating Humidifier Maintenance

The humidifier drains and refills to maintain a current setpoint and alert the operator when the humidifier canister needs to be replaced.



WARNING! Arc flash and electric shock hazard. Open all local and remote electric power supply disconnect switches, verify with a voltmeter that power is Off and wear appropriate, OSHA approved personal protective equipment (PPE) per NFPA 70E before working within the electric control enclosure. Failure to comply can cause serious injury or death. Customer must provide earth ground to unit, per NEC, CEC and local codes, as applicable. Before proceeding with installation, read all instructions, verify that all the parts are included and check the nameplate to be sure the voltage matches available utility power. The Vertiv™ Liebert® iCOM™ controller does not isolate power from the unit, even in the Unit Off mode. Some internal components require and receive power even during the Unit Off mode of the controller. The only way to ensure that there is NO voltage inside the unit is to install and open a remote disconnect switch. Refer to unit electrical schematic. Follow all local codes.



WARNING! Risk of improper wiring, piping, moving, lifting, and handling. Can cause equipment damage, serious injury, or death. Installation and service of this equipment should be done only by qualified personnel, wearing appropriate, OSHA approved PPE, who have been specially trained in the installation of air conditioning equipment.



WARNING! Risk of smoke and fire. Can cause activation of fire suppression systems, building evacuation, dispatching of fire/rescue equipment and personnel and catastrophic canister failure resulting in water leaks, equipment damage, injury, or death. Using a humidifier canister that has reached the end of its service life can be extremely hazardous. If the canister cannot be replaced immediately at the end of life condition, turn Off the power and water supply to the humidifier and remove the canister until a replacement canister can be installed. Do not ignore humidifier problem alarms. Resetting humidifier without addressing cause may result in fire or damage due to leaking water.



CAUTION: Risk of contact with hot surfaces. Can cause burn injury. The humidifier canister and steam discharge lines are extremely hot during operation. Allow sufficient time for them to cool to a touch safe temperature before handling. Use extreme caution and wear appropriate, OSHA approved PPE when performing maintenance on the humidifier.

After an extended period of operation, in accordance with life expectancy information, the cylinder is completely used as indicated by the amber high water sensor light illuminated on the cabinet. When this condition is reached, a new replacement cylinder must be installed.

NOTE: The amber high water sensor light may come on during initial start-up, but this instance does not indicate that the cylinder should be replaced.

The steam cylinder is disposable and must be replaced at the end of the cylinder's life. Cylinder life will vary according to water supply conditions and humidifier use.

10.8.1 Operating the Humidifier

1. During start-up, when the humidity control calls for humidification, the fill valve opens and allows water to enter the canister. When the water level reaches the electrodes, current flows and the water begins to warm. The canister fills until the amperage reaches the setpoint and the fill valve closes. As the water warms, its conductivity increases and the current flow, in turn, rises. If the current reaches 115% of the normal operating current, the drain valve opens and drains some of the water out of the canister. This reduces electrode contact with the water and lowers the current flow to the amperage setpoint. Boiling soon commences, and the canister operates normally.
2. If the conductivity of the water is low, the canister fills and the water level reaches the canister full electrode before the current setpoint is reached. The humidifier stops filling to prevent overflow. Boiling should commence in time. As water is boiled off, the mineral concentration in the canister increases and current flow also increases. The canister eventually reaches full output and goes to normal operation. No drain is permitted until then.
3. When full output is reached the circuit board starts a time cycle which is factory set at 60 seconds. During this repeating time cycle, the fill valve will open periodically to replenish the water being boiled off and maintain a steady state output at the setpoint. The amperage variance depends on the conductivity of the water.
4. After many cycles, the mineral concentration in the canister becomes too high. When this occurs, the water boils too quickly. As the water quickly boils off and less of the electrode is exposed, the current flow decreases. When the current crosses the low threshold point before the end of the time cycle, the drain valve opens, draining the mineral laden water out and replacing it with fresh water. This lowers the mineral concentration and returns the canister to steady state operation and prolongs canister life. The frequency of drains depends on water conductivity.
5. Over a period of time, the electrode surface becomes coated with a layer of insulating material which causes a drop in current flow. As this happens, the water level in the canister will slowly rise exposing new electrode surface to the water to maintain normal output. Eventually, the steady state water level will reach the canister full electrode and indicate so by activating the canister full alarm and opening the humidifier contactor. At this point, all of the electrode surface has been used up and the canister must be replaced.
6. After the entire electrode surface has been coated, the output will slowly begin to fall off. This usually occurs in the last several hours of electrode life and should allow enough time to schedule maintenance. During these last hours, the mineral concentration can increase. If the mineral concentration is too high, arcing can occur. If the electrodes start to arc, turn off the humidifier immediately and replace the canister with the identical part.

10.8.2 Replacing the Canister

The humidifier RUN/DRAIN switch is located in humidifier assembly. This switch should be in the RUN position when the humidifier is in normal operation. It should be in the DRAIN position when a manual drain for service is required. The electronic control board for the humidifier is located in the same area as the humidifier assembly. When the unit is energized, power is available to the humidifier circuits.

1. Turn off the humidifier by lowering the humidity setpoint below the ambient humidity level.
Record the original setpoint.
2. Place the RUN/DRAIN switch in the DRAIN position to drain the water from the canister.
3. Return the RUN/DRAIN switch to the RUN position after the canister has drained.
4. Turn Off the power at the main unit.
5. Remove the cover from the humidifier cabinet.

6. Locate the power wires to the steam canister. They are connected to the canister with 1/4-inch quick connects. Make note of the wiring configuration before removing any wires. Refer to the schematic on the unit. Slide the rubber boot back to expose the connections. Remove the two power wires and the canister wire. Do not loosen the screws that secure the electrodes.
7. Loosen the steam outlet hose clamps and slide the steam hose away from the canister fitting.
8. Release the canister clamp along the base of the canister.
The canister is now ready to be removed.
9. Remove the canister.
10. Reverse these steps to replace the canister, taking special note of the following:
 - When replacing wiring, connect the red wire from terminal #1 on the interface to the red tip terminal on the canister. Reconnect the power wires as they were formerly connected (#2 on the left and #1 on the right).
 - Always check the fill and drain solenoids for proper operation after replacing the canister.

10.8.3 Circuit Board Adjustments

Humidifier operation is governed by the humidifier control board. There are three potentiometers mounted on the board. These pots can be used to adjust for extreme water conductivity conditions and capacity.

POT2 controls the amperage at which the drain will energize. The pot is clearly marked in percentages. This adjustment is factory set at 85%, which indicates that the unit will drain when the amperage falls off to 85% of the capacity setpoint. Raising the value increases the frequency of drain cycles. Lowering the value decreases the frequency of drain cycles. The frequency should be increased for highly conductive water and decreased for less conductive water. If adjustment is necessary and a change of three to four percent in either direction does not permit normal operation of the unit, consult your Vertiv supplier.

POT1 controls the duration of the drain cycle. The pot is clearly marked in seconds. This adjustment is factory set at 60 seconds and should not be readjusted without consulting your Vertiv supplier.

POT3 is factory set at 100%. The maximum capacity of the system is not field adjustable.



WARNING! Risk of electric shock. Can cause injury or death. The DIP switches must be set exactly as indicated in Table 10.2 below. Failure to correctly set the DIP switches may result in an electrical or water hazard.

The DIP switch sets the capacity of the humidifier. If you replace the humidifier, set the DIP switches on the circuit board based on the voltage and capacity of your unit shown in Table 10.2 below.

Table 10.2 DIP Switch Settings for Humidifier Control Board

Voltage	SW1	SW2	SW3	SW4	Amps
208	On	On	On	Off	8.9
240	Off	On	On	Off	8.5
380/415	Off	Off	Off	Off	5.2
460	On	On	On	Off	4.5
575	On	On	Off	Off	3.4

This page intentionally left blank

11 Preventive Maintenance Checklist

Source: DPN002953, Rev 2

Inspection Date	Job Name
Indoor Unit Model #	Indoor Unit Serial Number #
Condensing Unit Model #	Condensing Unit Serial #
Room Temperature/Humidity ° %	Ambient Temperature °

Not all units will have all components. To determine your unit's configuration, compare the Indoor Unit Model # above and the information in the Components and Nomenclature section.

Good maintenance practices are essential to minimizing operation cost and maximizing product life. Read and follow all applicable maintenance checks listed below. At a minimum, these checks should be performed semi-annually. However, maintenance intervals may need to be more frequent based on site specific conditions. Review the unit user manual for further information on unit operation. We recommend the use of trained and authorized service personnel, extended service contracts, and factory certified replacement parts. Contact your local sales representative for more details.

Check all that apply:

Evaporator/Filters

- 1. Check/Replace filters.
- 2. Wipe section clean.
- 3. Make sure coil is clean.
- 4. Clean condensate pan.
- 5. Clean trap in condensate drain.
- 6. Drain connection/lines open, leak free and in good condition.
- 7. Check/Test filter clog switch operation (If equipped).
- 8. Check/Test condensate drain pan float switch operation (If equipped).

Blower Section

- 1. Blower wheels free of debris.
- 2. Check motor mount.
- 3. Check motor amp draw.

L1 _____ L2 _____ L3 _____

(L1 and L2 on single-phase units)

- Compare to nameplate amps.

Reheat (if equipped)

- 1. Inspect elements and check for corrosion.
- 2. Check/Re-torque wire connections (inside reheat box).
- 3. Reheat amp draw.

L1 _____ L2 _____ L3 _____

Steam Generating Humidifier (If Equipped)

1. Check drain valve/drain lines/trap for clogs.
2. Check water fill valve and all hoses for leaks.
3. Check condition of steam hose.
4. Check canister for mineral deposits.
5. Check condition of the electrodes.
6. Clean strainer.
7. Replace humidifier bottle, if necessary.
8. Check operation of humidifier.
9. Check humidifier amp draw.

L1 _____ L2 _____ L3 _____

Condensate Pump (If Equipped)

1. Check for debris in sump.
2. Check operation of float(s) (free movement).
3. Check/Clean discharge check valve.
4. Check drain connection/lines for leaks.

Overflow Drain Pan (Ducted Units (If Equipped))

1. Drain connection and lines open and free of debris.
2. Drain line empties into a maintenance sink or condensate pump.
3. Water detection device/system installed and monitored. Check operation (If installed).

Electrical Panel

1. Check fuses.
2. Check contactors for pitting. (Replace if pitted.)
3. Check/Re-torque wire connections.

Controls

1. Check/Verify control operation (sequence).
2. Check/Test changeover device(s) (if equipped).
3. Check/Test water detection device(s) (if equipped).

Refrigeration Piping

1. Check refrigerant lines (clamps secure/no rubbing/no leaks).
2. Check for moisture (sight glass).
3. Check for restriction temperature drop across filter drier.

Compressor Section

1. Check oil level.
2. Check for oil leaks.
3. Check compressor mounts (springs/bushings).
4. Check cap tubes (not rubbing).
5. Check/Re-torque wire connections (inside compressor box).
6. Check compressor operation (vibration/noise).
7. Check crank case heater fuses/operation (if equipped).
8. Check for refrigerant leaks.
9. Suction pressure _____
10. Discharge Pressure _____
11. Superheat _____
12. High pressure cut out _____
13. Compressor amp draw _____

L1 _____ L2 _____ L3 _____

(L1 and L2 on single-phase units)

Econ-O-Coil (If Equipped)

1. Verify proper water/glycol maintenance/treatment is being performed.
2. Verify that continuous water/glycol flow is maintained.
3. Check for water/glycol leaks.
4. Check valve operation.

Air Cooled Condensing Unit (If Equipped)

1. Coil clean/free of debris .
2. Motor mounts tight.
3. Bearings in good condition.
4. Refrigerant lines properly supported.
5. Check motor amp draw.

L1 _____ L2 _____ L3 _____

(L1 and L2 on single-phase units)

Water/Glycol Cooled Condenser (If Equipped)

6. Check water regulating valve operation.
7. Verify water flow/continuous flow is maintained.
8. Clean screen on Y-strainer (if equipped).
9. Check cap tubes (not rubbing).
10. Check for water/glycol leaks.
11. Entering water temperature _____°
12. Leaving water temperature _____°

This page intentionally left blank

12 Troubleshooting



WARNING! Risk of electric shock. Can cause injury or death. Open all local and remote electrical power disconnect switches and verify with a voltmeter that power is off before working within electrical enclosures. Hazardous voltage will be present at evaporator, condensing unit, reheat, and humidifier even with the unit turned Off at the control panel. With power and controls energized, the unit could begin operating automatically without warning.

Table 12.1 on page 101, describes the possible causes, and actions to take when troubleshooting an issue.

Table 12.1 Troubleshooting

Symptom	Possible Causes	Check or Remedy
Unit will not start	No power to unit.	Check voltage at input terminal block.
	Control voltage circuit breaker (at transformer) open.	Locate short and reset circuit breaker.
	Float switch relay has closed due to high water in the condensate pan.	Has rubber band been removed from float switch? Check drain and line. Access from bottom through discharge air grille. Power must be cycled at the disconnect to reset.
	Jumper not in place.	Check terminal TB1-4 and TB1-5 for jumper or N/C contact. Check Pins 1-8 and 1-9 for jumper or N/C optional high temperature sensor contact. Check Pins 5-4 and 5-5 for jumper or N/C smoke detector contact.
No cooling	Cooling is not displayed at the control panel.	Adjust TEMP control setpoint and sensitivity to require cooling.
	Short cycle prevention control.	Control software delays compressor three minutes cooling, from stop to start.
	Compressor contactor not pulling in.	Check for 24 VAC \pm 2 VAC at terminals P4-8 and P4-4. If voltage is detected, check contactor. If there is no voltage at P4-8 and P4-4, check at terminals P2-3 and P2-8. If voltage, check freezestat.
	Compressor high head pressure.	See below for cause.
	Plugged filter/drier.	Replace filter/drier.
Low refrigerant charge.	Check pressure gauges. See the tables in Refrigerant Charge Requirements on page 37 for recommended pressures. At low ambient temperatures, proper refrigerant charge is very important on units with Lee-Temp receivers.	

Table 12.1 Troubleshooting (continued)

Symptom	Possible Causes	Check or Remedy
Compressor high head pressure alarm	Insufficient air flow across condenser coil.	Remove debris from coil and air inlets.
	Water/Glycol cooled only: No fluid flowing through condenser.	Check fluid supply to regulating valve. Clean Y-strainer filter, if installed. Adjust valve if necessary.
	Unshielded control wires used between split system units.	Check for shielded control wires used and for shielded wire connection to earth (ground) at the Liebert® equipment. Route low voltage wires separate from high voltage lines and away from loads such as light ballasts.
Reheat will not operate	DIP switch not set to enable reheat option.	See DIP switch settings Equipment Options DIP Switches on page 65 .
	HEAT not displayed at the control panel.	Increase temperature setpoint to require heating.
	Reheat safety open, defective reheat contact or defective board	Check voltage at P2-1 and P1-9 on interface board for 24 VAC ± 2 VAC. If voltage, check reheat contactor and reheat safety. If no voltage, check wiring and/or replace board.
	Element is burned out	Turn off power. Check element continuity with Ohm meter.
	GCD has tripped	Replace GCD and heating element.
Display freezes and control pads do not respond	Static discharge	During period of low humidity, static electricity can cause the control program to freeze or display incorrect information. Although this is unlikely, the control can be reset by cycling power from the disconnect switch.

Table 12.1 Troubleshooting (continued)

Symptom	Possible Causes	Check or Remedy
Humidifier does not operate	DIP switch not set to enable humidifier option.	See DIP switch settings Equipment Options DIP Switches on page 65 .
	HUMIDIFY not displayed at control panel.	Increase humidity control setpoint and sensitivity to require humidification.
	Defective board	Check voltage at P3-1 and P1-9 on interface board for 24 VAC \pm 2 VAC. If no voltage, check wiring and/or replace board. Check wiring from control panel to board.
	Failed humidity sensor	Humidity display will indicate dashes. Check wiring from temperature/ humidity board to the control board and from the wall box to the control board. Replace wall box or temperature/humidity circuit board (if remote).
	No water flow	Make sure switch is in Run position. Check humidifier water supply (including filter screen) and check nylon overflow line if canister is full.
	Canister fill rate is not keeping up with the steam output.	Check fill valve screen opening and capillary tube for obstructions. Check water supply pressure (minimum 10 psig [69 kPa]).
Cooling cycle too short	Sensor response delay too short.	Increase sensor response delay. See Calibrating Sensors and Setting Sensor Response Delay on page 62 .
Condensate pump does not operate.	Open or short circuit in wiring	Find open or short circuit and repair power to pump.
Continuous Cooling	Failed temperature sensor	Temperature display will indicate dashes. Check wiring from temperature/humidity board (remote sensors) to the control board or from control board to the wall box. Replace temperature/humidity circuit board (remote sensors) or wall box.
Continuous Cooling Dehumidification Humidification	Shorted wiring or failed control board	Check wiring and/or replace control board.

This page intentionally left blank

Appendices

Appendix A: Technical Support and Contacts

A.1 Technical Support/Service in the United States

Vertiv Group Corporation

24x7 dispatch of technicians for all products.

1-800-543-2378

Liebert® Thermal Management Products

1-800-543-2378

Liebert® Channel Products

1-800-222-5877

Liebert® AC and DC Power Products

1-800-543-2378

A.2 Locations

United States

Vertiv Headquarters

505 N. Cleveland Ave.

Westerville, OH 43082, USA

Europe

Via Leonardo Da Vinci 8 Zona Industriale Tognana

35028 Piove Di Sacco (PD) Italy

Asia

7/F, Dah Sing Financial Centre

3108 Gloucester Road, Wanchai

Hong Kong

This page intentionally left blank

Appendix B: Submittal Drawings

Table 14.1 Submittal Drawings Contents

Document Number	Title
Planning Dimensions - Split System Evaporators/Chilled Water Units	
DPN000218	Evaporator/Chilled Water and Option Dimensions
Planning Dimensions - Indoor Condensing Units	
DPN004422	Cabinet Dimensions, Air Cooled Units
DPN004423	Cabinet Dimensions, Water/Glycol Cooled units
Piping General Arrangement	
DPN004412	Piping Schematic, Water/Glycol Cooled
DPN004413	Piping Schematic, Air Cooled and Chilled Water
DPN000219	Piping Schematic, Free Cooling and Hot Water Reheat Options
Piping Connections - Evaporator and Chilled Water Units	
DPN004304	Piping Connections
Condensate Pump Connection	
DPN000217	Field-installed pump connection
Piping Connections - Split System Indoor Condensing Units	
DPN004422	Piping Connections, Air Cooled Units
DPN004423	Piping Connections, Water/Glycol Cooled Units
Electrical Connections - Evaporator and Chilled Water Units	
DPN000221	Electrical Connections
DPN000220	Single-point Power Kit for Close Coupled Units
DPN004852	Arrangement and Dimensions, Unit Mounted IS-UNITY-DP for BMS Communication
DPN004911	Arrangement and Dimensions, Wall Mounted IS-UNITY-DP for BMS Communication
DPN004854	Electrical Connections, IS-UNITY-DP for BMS Communication
Electrical Connections - Split System Indoor Condensing Units	
DPN004297	Electrical Connections, Air Cooled
DPN004298	Electrical Connections, Water/Glycol Cooled

CABINET DIMENSIONAL DATA 5 TON CHILLED WATER MODELS

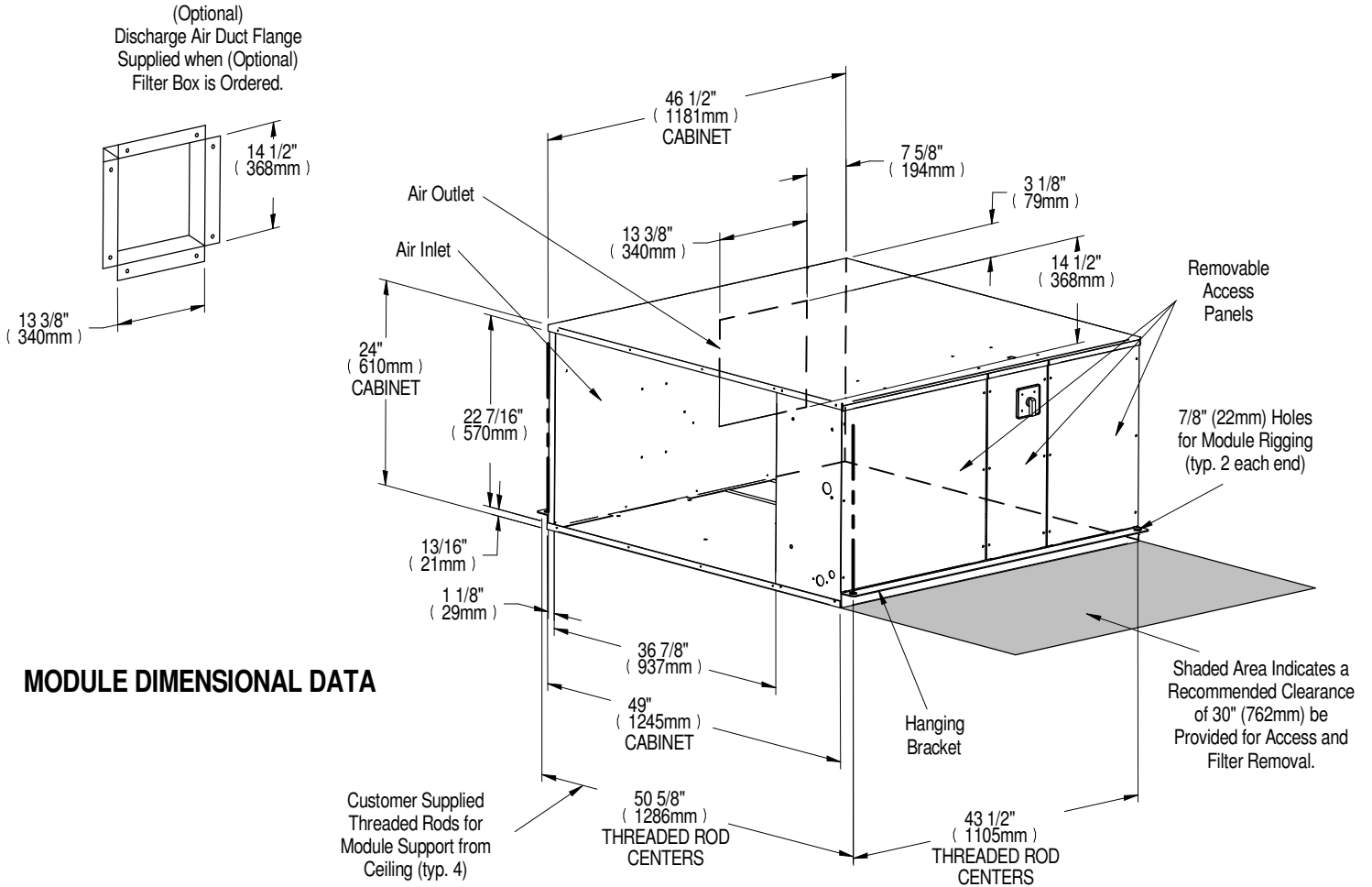

MODULE DIMENSIONAL DATA

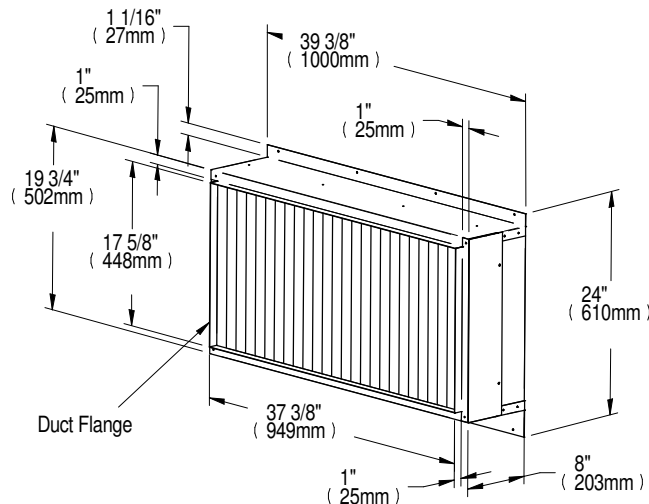

UNIT NET WEIGHT lbs. (kg)	
60 HZ	
MM*92C	498 (226)

(OPTIONAL) FILTER BOX



VERTIV™

LIEBERT® MINI-MATE2

CABINET DIMENSIONAL DATA & PRIMARY CONNECTION LOCATIONS 5 TON AIR COOLED INDOOR CONDENSING MODULE

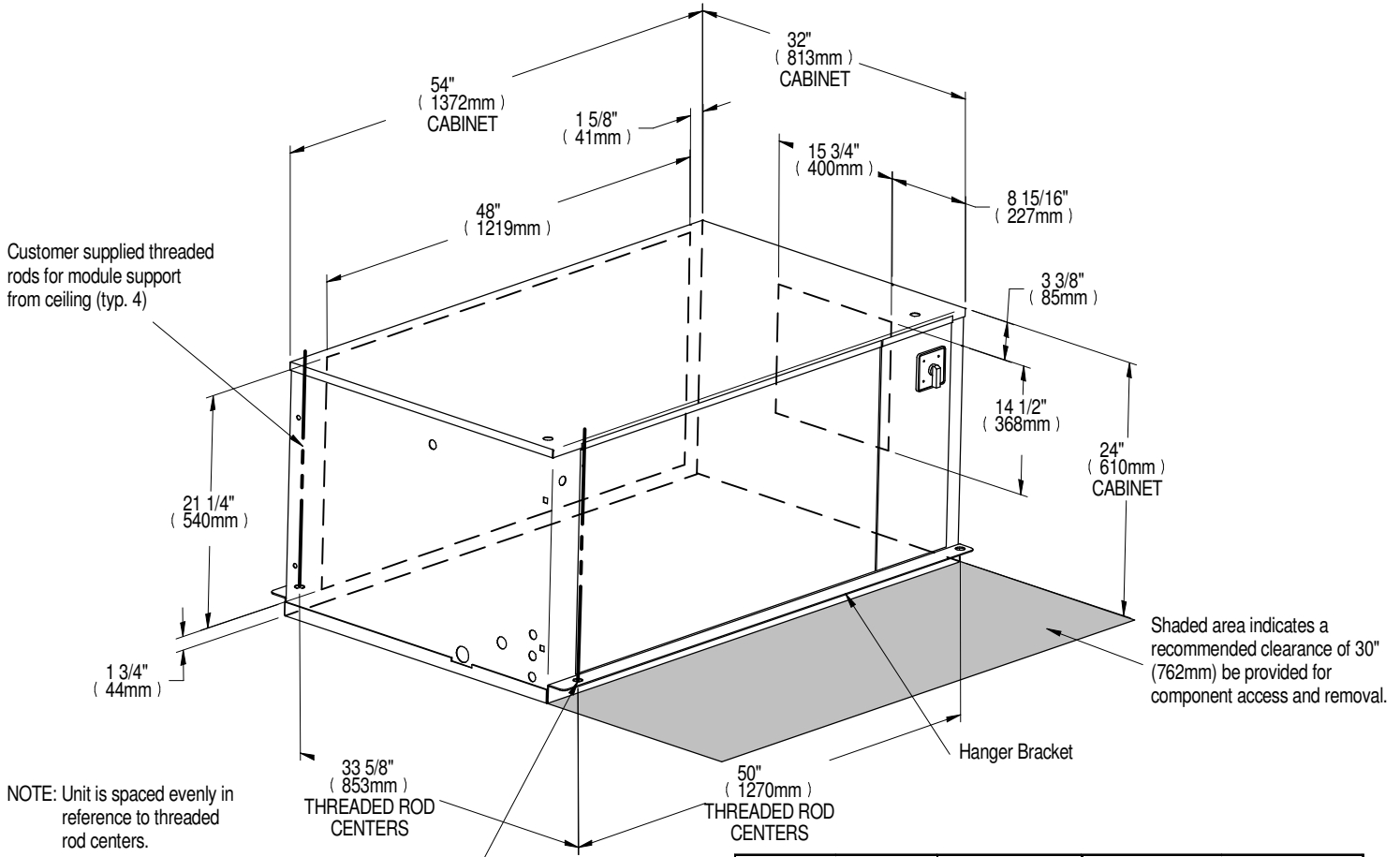

MODEL #		UNIT NET WT lbs. (kg)	Refrigerant Connection sizes O.D. Cu	
60 HZ	50 HZ		Suction	Liquid
MC*65A	MC*64A	449 (204)	7/8"	1/2"

7/8" (22.2mm) & 1 1/8" (28.6mm) dia. knockouts electrical entrance for high voltage connection.



LIEBERT® MINI-MATE2

CABINET DIMENSIONAL DATA & PRIMARY CONNECTION LOCATIONS

5 TON WATER/GLYCOL COOLED INDOOR CONDENSING MODULE

NOTE: Unit is evenly spaced in reference to threaded rod centers.

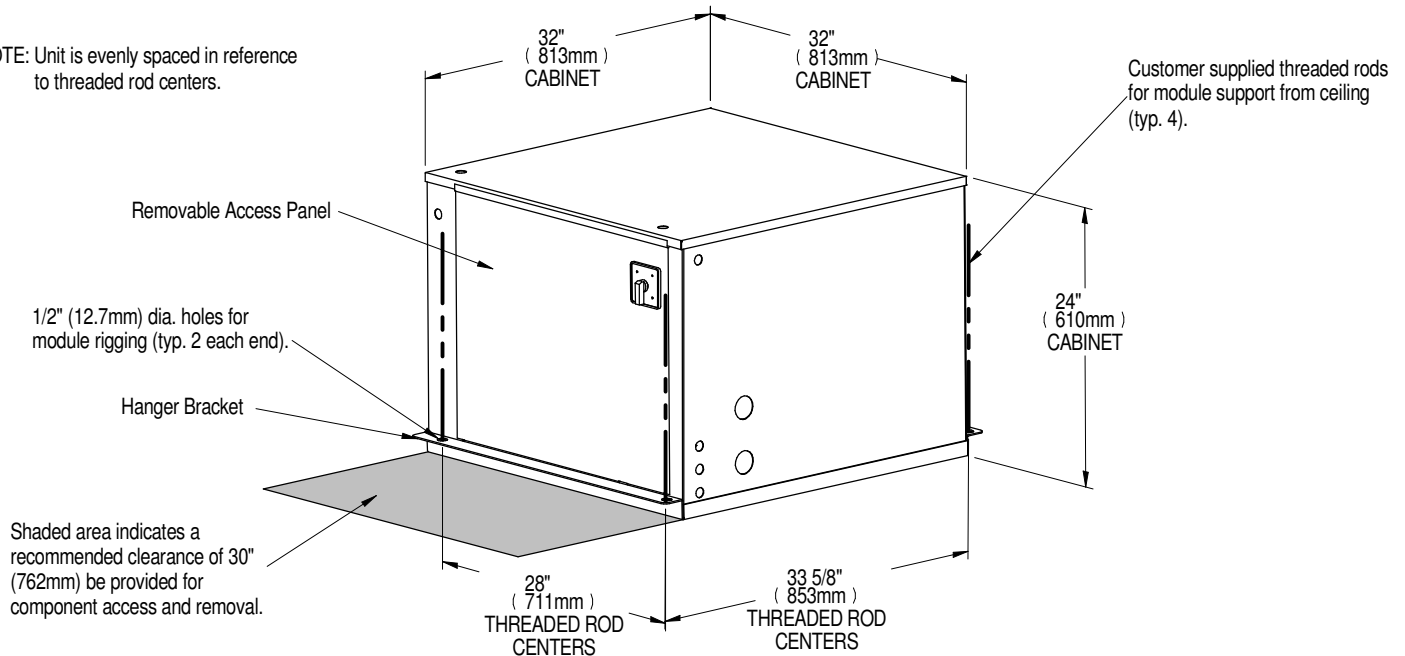

MODEL #		UNIT NET WEIGHT lbs. (kg)	Refrigerant Connection sizes O.D. Cu	
60 HZ	50 HZ		Suction	Liquid
MC*69W	MC*68W	282 (128)	7/8"	1/2"

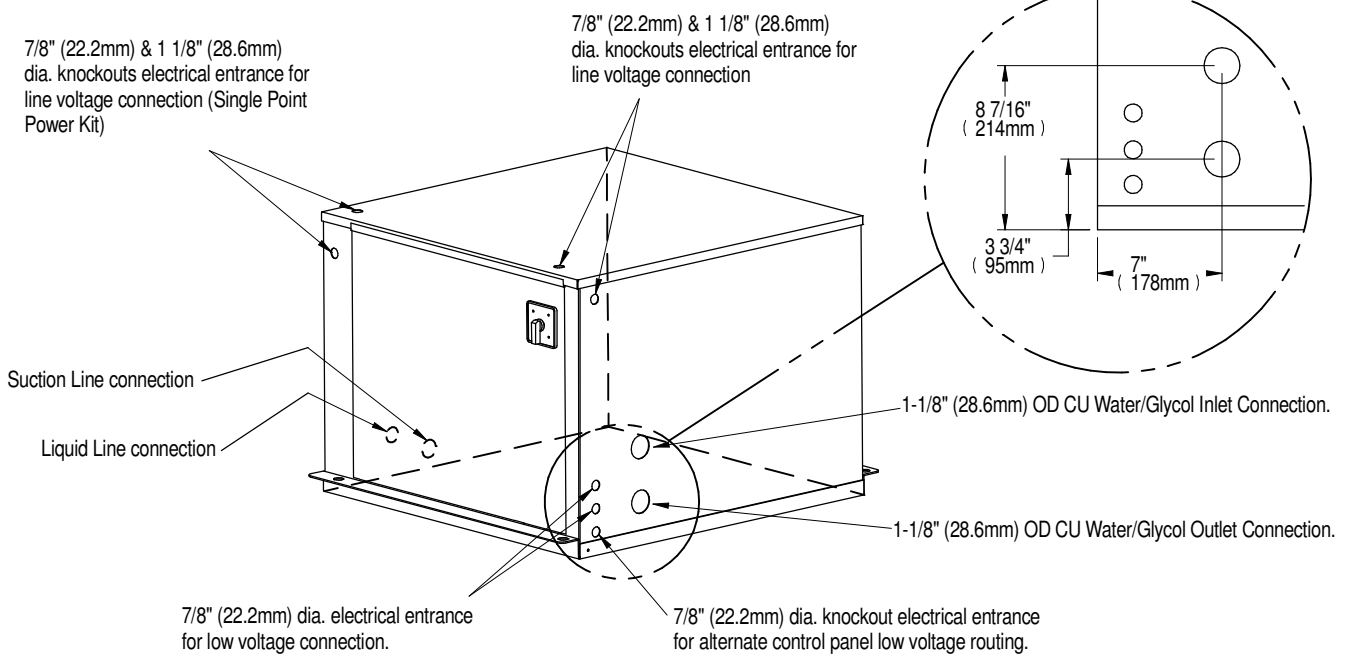

Form No.: DPN001040_REV14



VERTIV™

LIEBERT® MINI-MATE2

GENERAL ARRANGEMENT DIAGRAM 5 TON SPLIT SYSTEMS WATER/GLYCOL COOLED MODELS

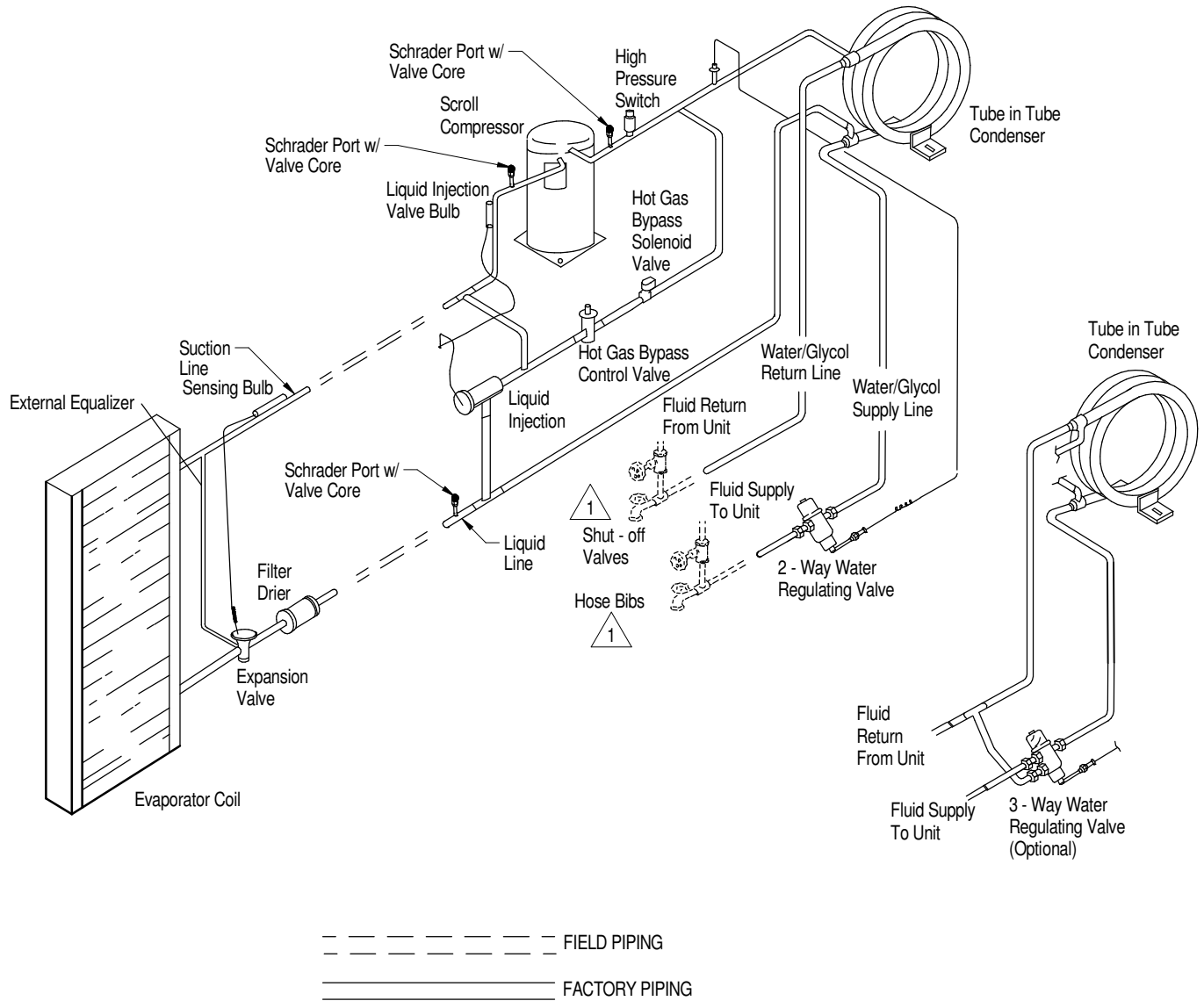

Notes:

1. Components are not supplied by Vertiv but are required for proper circuit operation and maintenance.



VERTIV™

LIEBERT® MINI-MATE2

GENERAL ARRANGEMENT DIAGRAM 5 TON CHILLED WATER MODELS

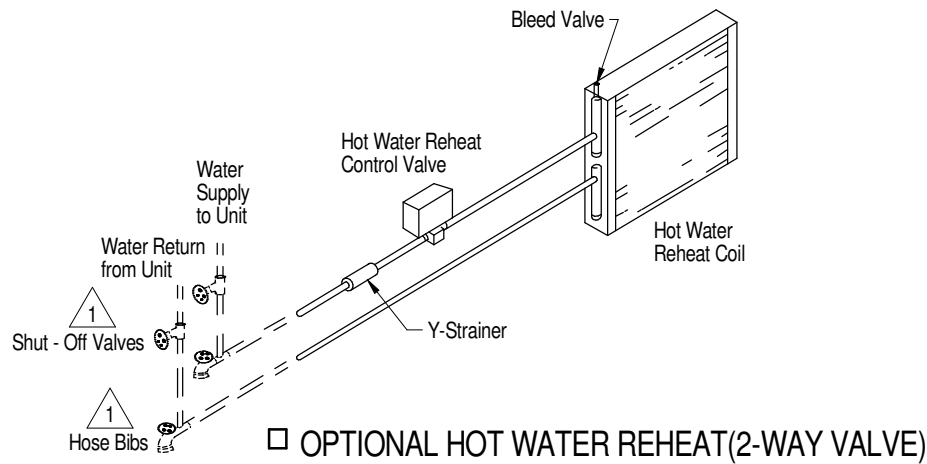
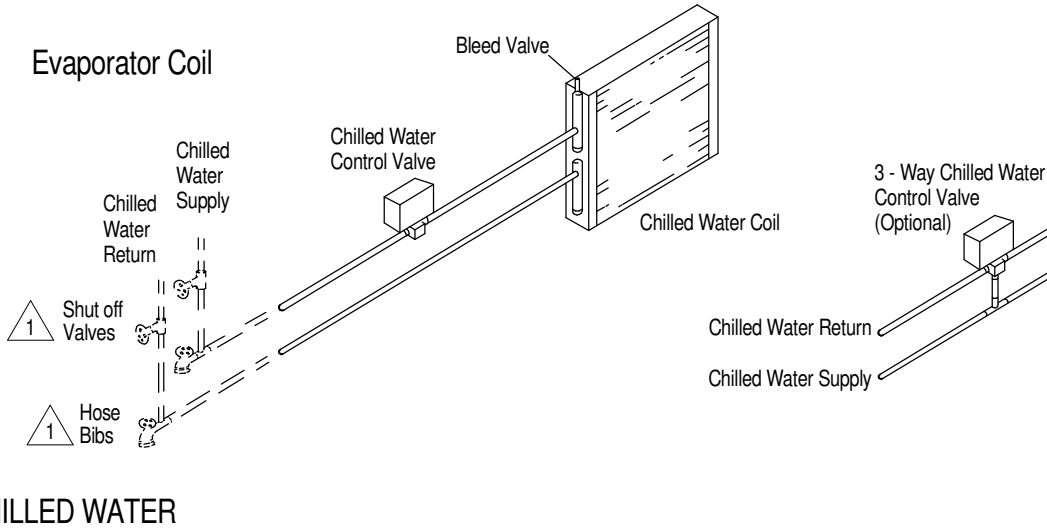

Notes:

1. Components are not supplied by Vertiv but are required for proper circuit operation and maintenance.

--- FIELD PIPING
==== FACTORY PIPING



VERTIV

LIEBERT® MINI-MATE2

GENERAL ARRANGEMENT DIAGRAM 5 TON FREE COOLING OR HOT WATER REHEAT COIL OPTIONS

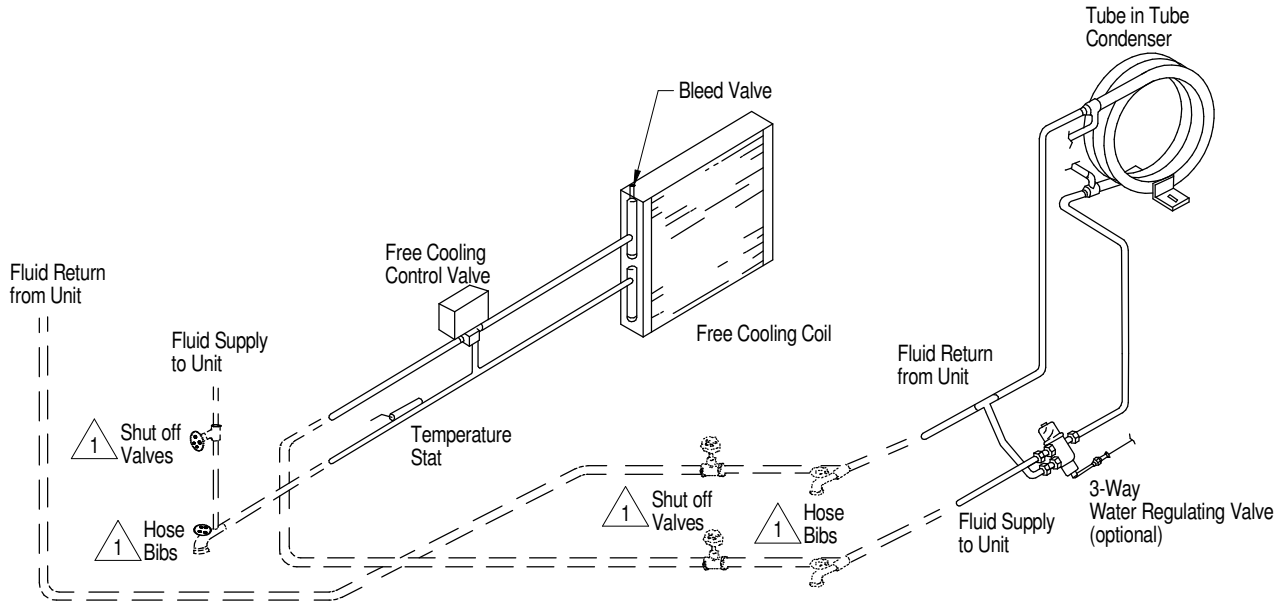

□ OPTIONAL FREE COOLING COIL (3-WAY VALVE)
ON WATER/GLYCOL UNITS

NOTE: RECOMMENDED PIPING FOR UNITS
WITH FREE COOLING COIL OPTION
AND WATER/GLYCOL CONDENSER.

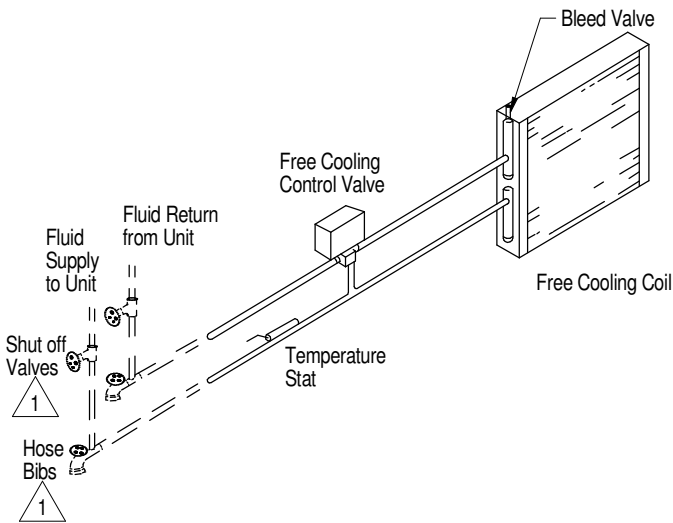

□ OPTIONAL FREE COOLING COIL (3-WAY VALVE)
ON AIR COOLED UNITS

NOTE: EACH MODULE IS AVAILABLE WITH ONLY
ONE OF THE ABOVE LISTED OPTIONS.

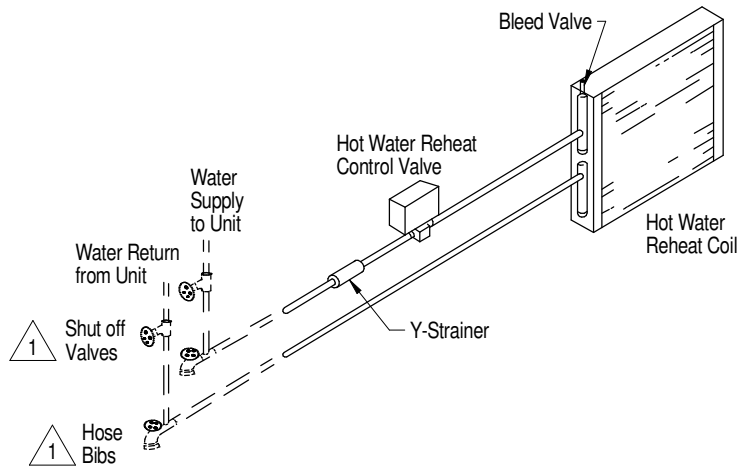

□ OPTIONAL HOT WATER REHEAT (2-WAY VALVE)
ON CHILLED WATER UNITS

NOTE: HOT WATER REHEAT ONLY AVAILABLE
ON CHILLED WATER UNITS.

===== FIELD PIPING
===== FACTORY PIPING

Notes:

1. Components are not supplied by Vertiv but are required for proper circuit operation and maintenance.



VERTIV

LIEBERT® MINI-MATE2

PRIMARY CONNECTION LOCATIONS 5 TON CHILLED WATER MODELS

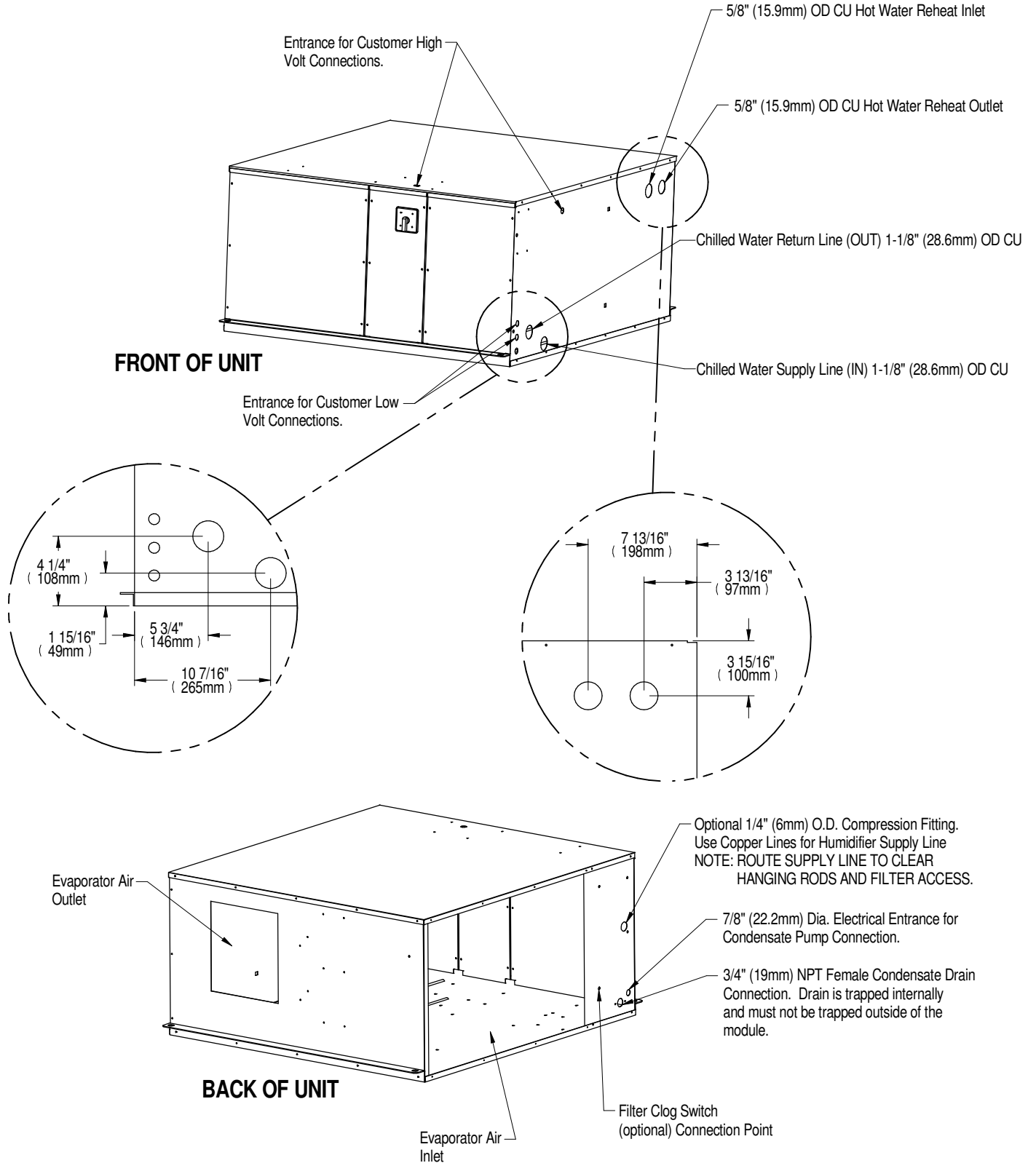



VERTIV™

LIEBERT® MINI-MATE2

SMALL SYSTEMS 5 TON CONDENSATE PUMP CONNECTION (OPTIONAL FIELD INSTALLED)

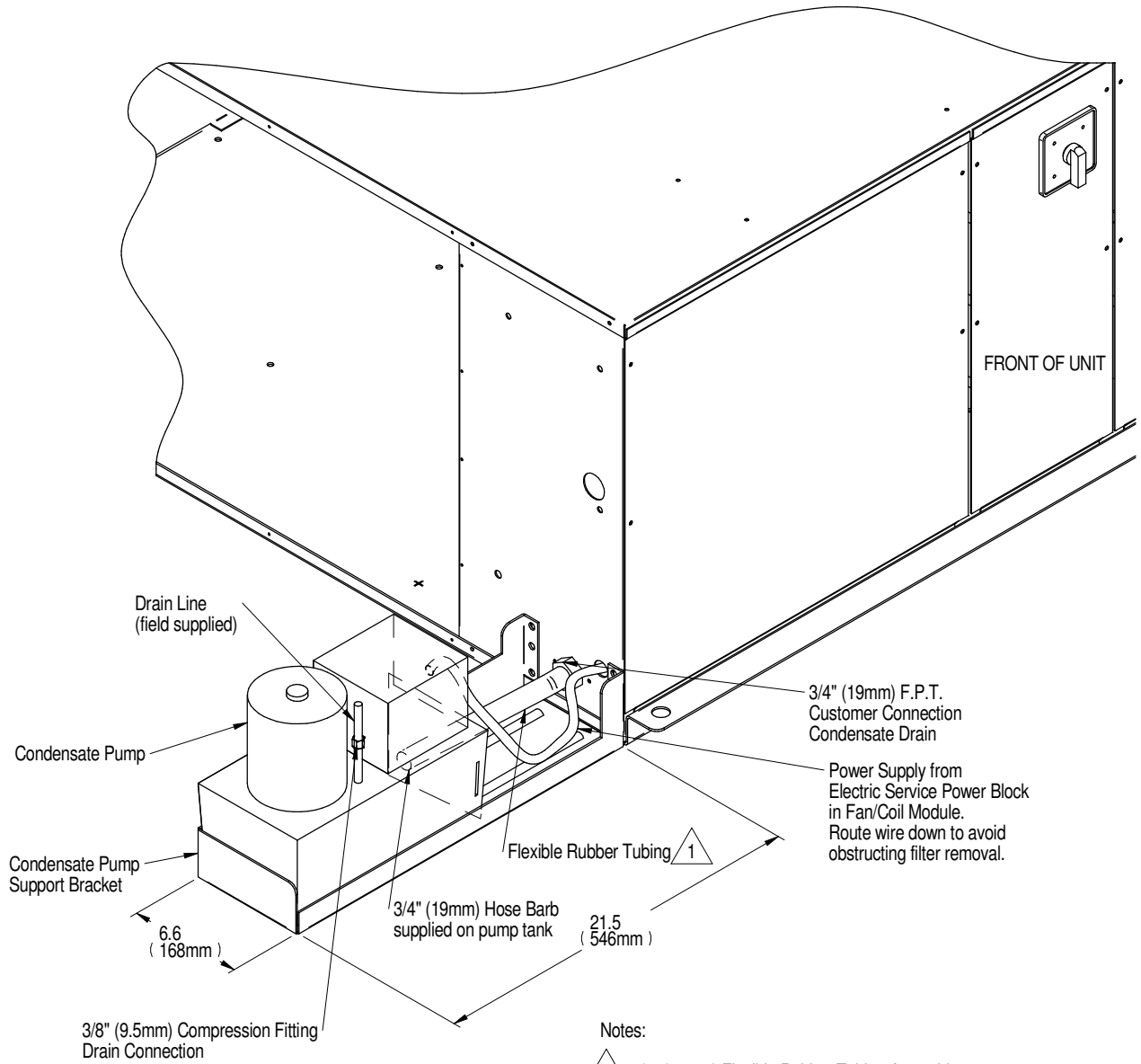

Notes:

1. 3/4" (19mm) Flexible Rubber Tubing Assembly (supplied with pump kit) must be installed on pump end.
2. The Auxiliary Float Switch included with pump must be field interlocked with unit control to enable unit shutdown feature. Wire to evaporator terminal per unit schematic.
3. Refer to DPN003401 for installation instructions.



VERTIV

LIEBERT® MINI-MATE2

ELECTRICAL FIELD CONNECTIONS

5 TON MODELS

Earth Ground Connection
Connection terminal for field
supplied earth grounding wire.

High Volt Power Connections
Electric service connection terminals.

Factory installed
disconnect switch.

Remote Humidifier Contact
Field Supplied 24V class 2
wiring to terminals 11 & 12,
located in field wire
compartment.

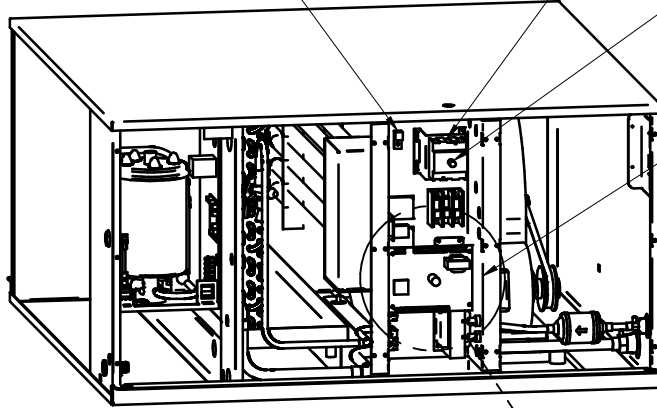

Optional Condensate Pump Auxiliary Float
Switch Connection to terminal TB1-8 and
TB1-9.

Customer Remote Alarm Connection. Field supplied 24V Class 2 wiring
to connection TB1-1, TB1-2 and TB1-3.

Remote Control Panel Connection to TB3-1,2,3,4 connected with field
supplied Thermostat wire (22ga, shielded/jacketed: available from
Liebert or others). Unit Control Board terminals marked GND, +5V, T-,
T+ must be connected to corresponding terminals on Remote Control
Wall Box.

Site Monitoring Connection. Terminals TB4-1(+) TB4-2(-) are for connection of a 2 wire,
twisted pair, communication cable (available from Liebert or others) to optional
Liebert® IS-UNITY-DP or Liebert® SiteScan.

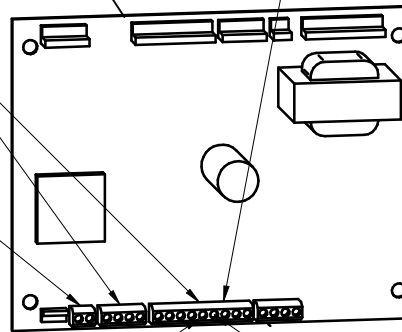

Remote Unit Shutdown. Replace existing jumper between terminals TB1-4 and TB1-5 with
normally closed switch having a minimum 75 VA rating. Use field supplied 24V Class 1 wire.

Common Alarm Connection.
Field supplied 24V Class 2 wiring to
common alarm connection TB1-6 and TB1-7.



Field supplied unit disconnect switch
when factory unit disconnect switch
is not supplied.

Entrance for customer high
volt connections.

Electric service not by Vertiv.

Electrical entrance for
optional condensate
pump on back of unit.

Field supplied, field wired thermostat
wire to remote wall box.

Entrance for customer low
voltage connections.

Entrance for customer
low voltage connections.

Optional Liebert® IS-UNITY-DP connection to
terminals 20 and 21 on lower right outside of electric box.
Field supplied 24V Class 2 wiring

Field supplied 24V (NEC Class 2 wiring)
to condensing module. (if applicable)

Notes:

1. Refer to specification sheet for full load amp and wire size amp ratings.
2. Control voltage wiring must be a minimum of 16GA (1.3mm) for up to 75' (23m) not to exceed 1 volt drop in control line.



LIEBERT® MINI-MATE2

SINGLE POINT POWER KIT 5 TON OPTIONAL FIELD INSTALLED

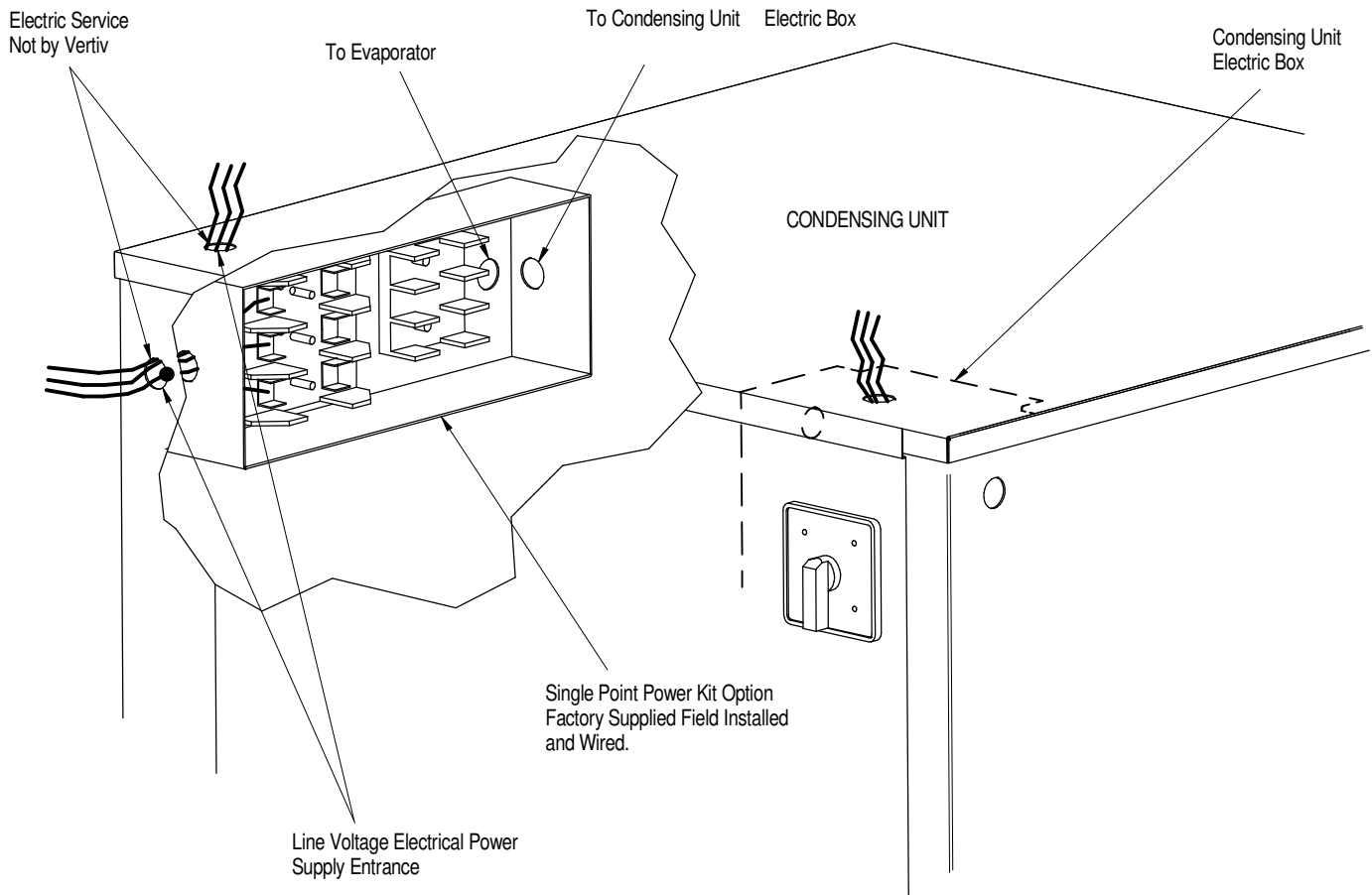

Notes:

1. Single Point Power Kit should be mounted inside the condensing unit before installing the unit in the ceiling.



VERTIV

LIEBERT® MINI-MATE2

GENERAL ARRANGEMENT & DIMENSIONAL DATA UNIT MOUNTED LIEBERT® IS-UNITY-DP ON 5 TON FOR BMS CONNECTIVITY

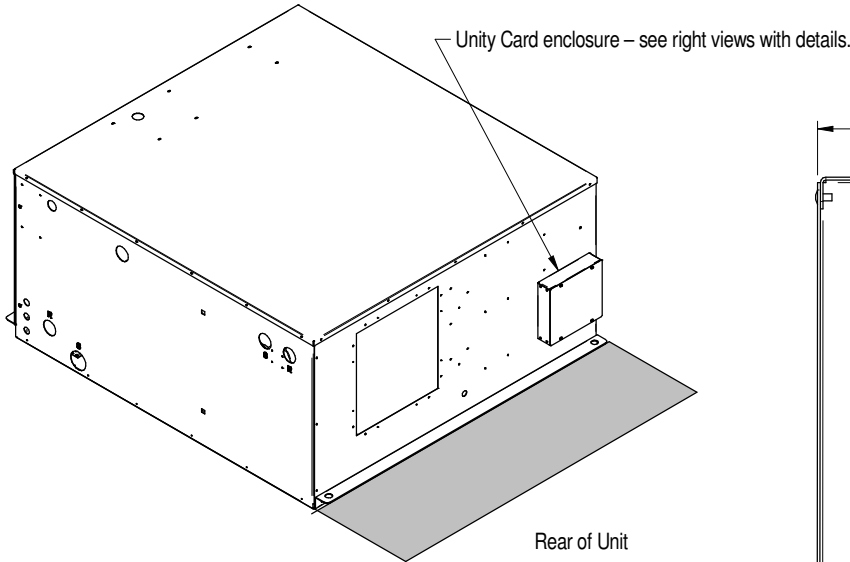

Shaded area indicates a recommended clearance of 30" (762mm) for component access and removal

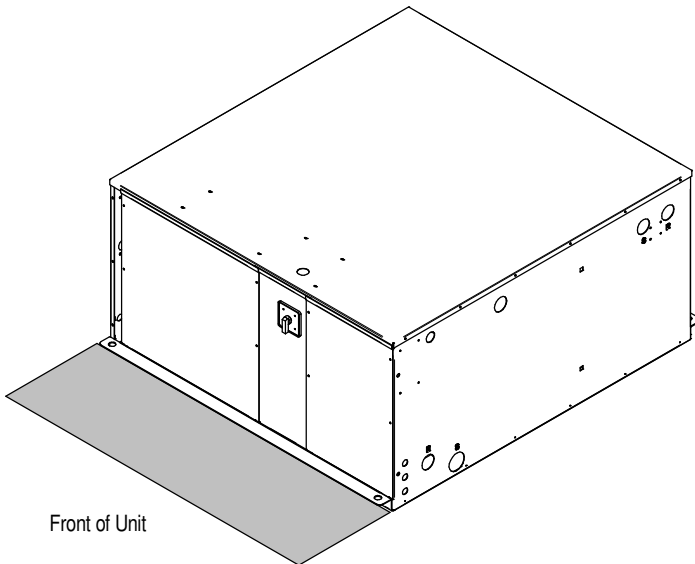

Shaded area indicates a recommended clearance of 30" (762mm) for component access and removal

Notes:

1. Refer to DPN004854 for field communication connections.

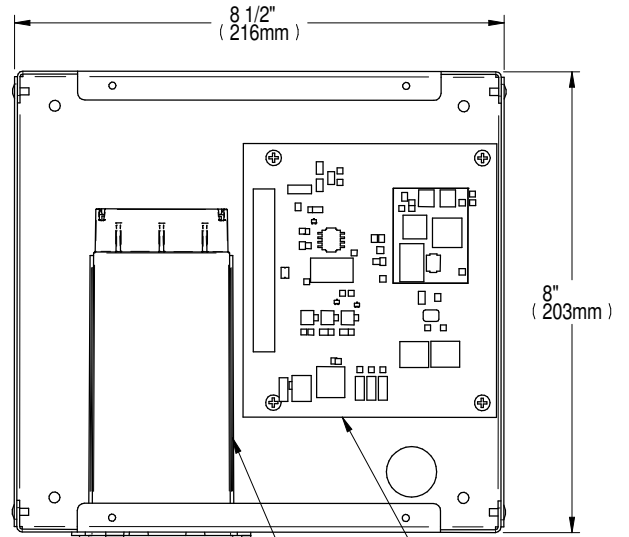

Cover removed for clarity. Removal not required for making field communication connections.

Liebert® IS-UNITY-DP CARD

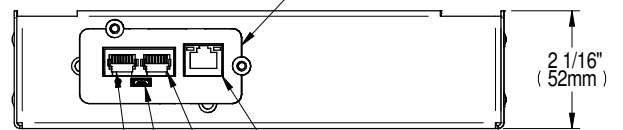

ETHERNET port
RS-485 port (using adaptor)

NOT USED
NOT USED

BOTTOM VIEW

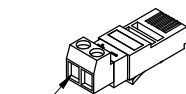

Adaptor plugged into BMS 485 port when unit is shipped



VERTIV™

LIEBERT® MINI-MATE2

GENERAL ARRANGEMENT & DIMENSIONAL DATA

WALL MOUNTED LIEBERT® IS-UNITY-DP CARD FOR BMS CONNECTIVITY

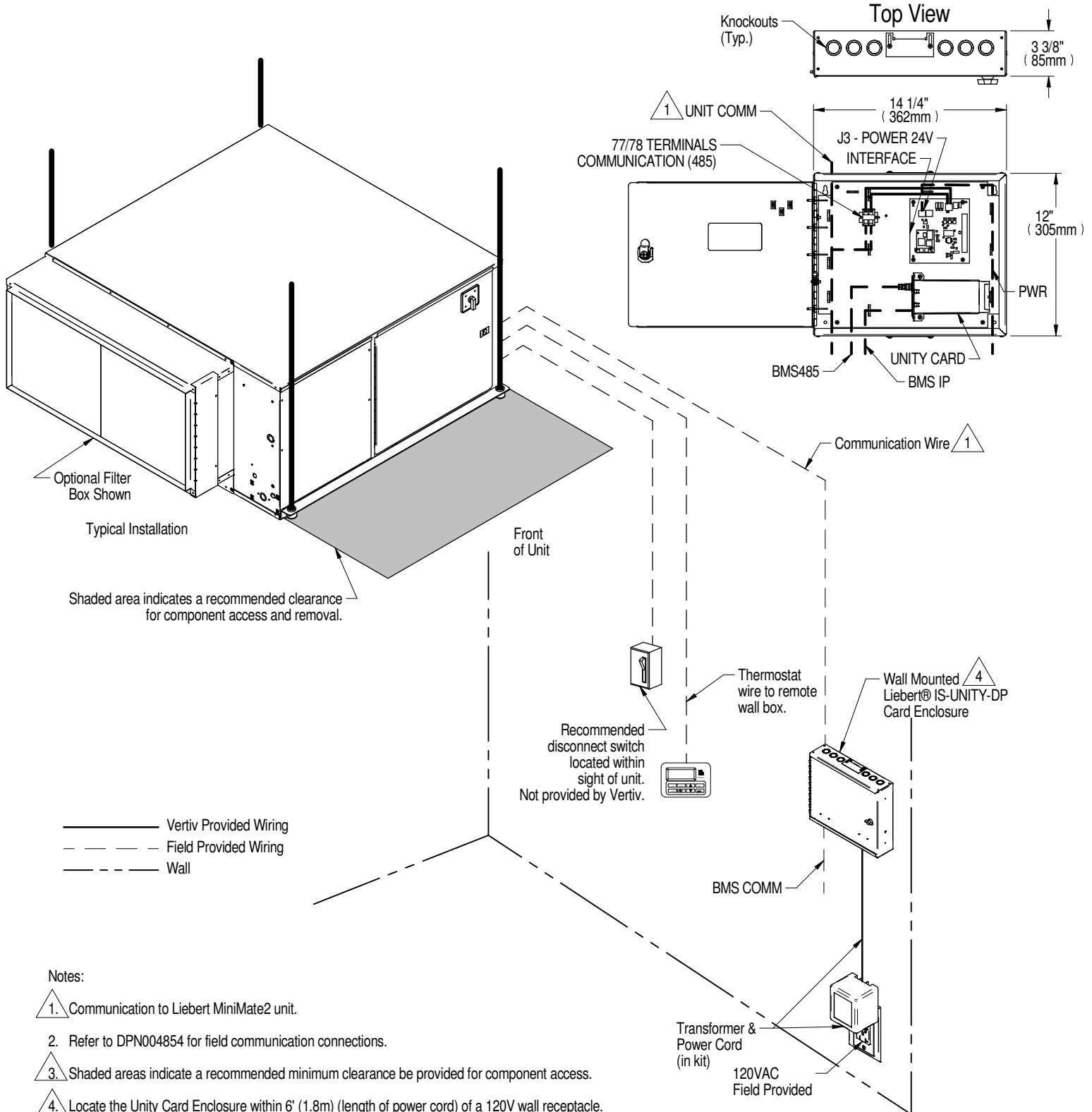

BMS COMMUNICATION CONNECTION OPTIONS LIEBERT® MINI-MATE2 & LIEBERT® DATAMATE

BMS IP/485
(1 Cooling Unit only)

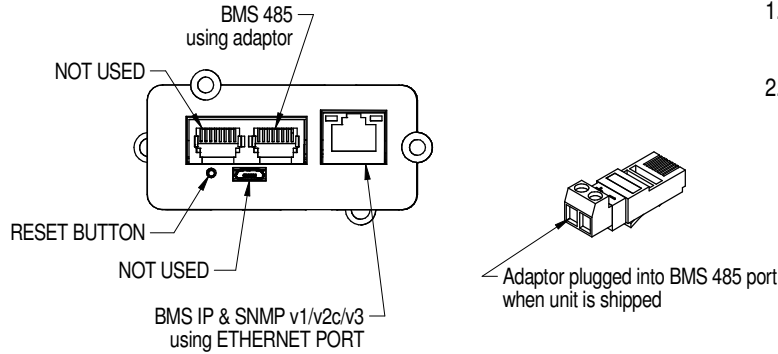

1. Building Management System (BMS) Protocols
 - *BACNet over IP/485
 - *Modbus over IP/485
2. Communication wiring is field supplied
 - IP - use CAT5e cable or greater
 - 485 - use EIA 485 rated, shielded, twisted pair cable, 22-18AWG.
 - Must be rated to meet local codes and conditions.

UNIT TO INTERFACE BOARD CONNECTIONS

	UNIT		UNIT MOUNTED KITs*		WALL MOUNTED KITs**	
	TERMINAL/PLUG	POSITION	TERMINAL/PLUG	POSITION	TERMINAL/PLUG	POSITION
Liebert® Mini-Mate2 1-5 Ton						
COMMUNICATION (485)	TB4	1 / 2	J2	2 / 1	77 / 78	N/A
POWER 24V	20, 21	N/A	J3	1 / 2	J3	1 / 2
Liebert® Mini-Mate2 8 Ton						
COMMUNICATION (485)	77, 78	N/A	J2	2 / 1	77 / 78	N/A
POWER 24V	TB1	4 / 8	J3	1 / 2	J3	1 / 2
Liebert® DataMate						
COMMUNICATION (485)	TB5	77 / 78	N/A	N/A	77 / 78	N/A
POWER 24V	N/A	N/A	N/A	N/A	J3	1 / 2

Notes

Terminals are presented in order of connection. For example, TB4-1 connects to J2-2.

* Unit mounted kits are provided with Unit Comm & power wire harnesses; BMS Comm are field provided.

** Wall mounted kits are provided with power wire harness and 120 Volt wall outlet transformer. Unit Comm & BMS Comm are field provided.

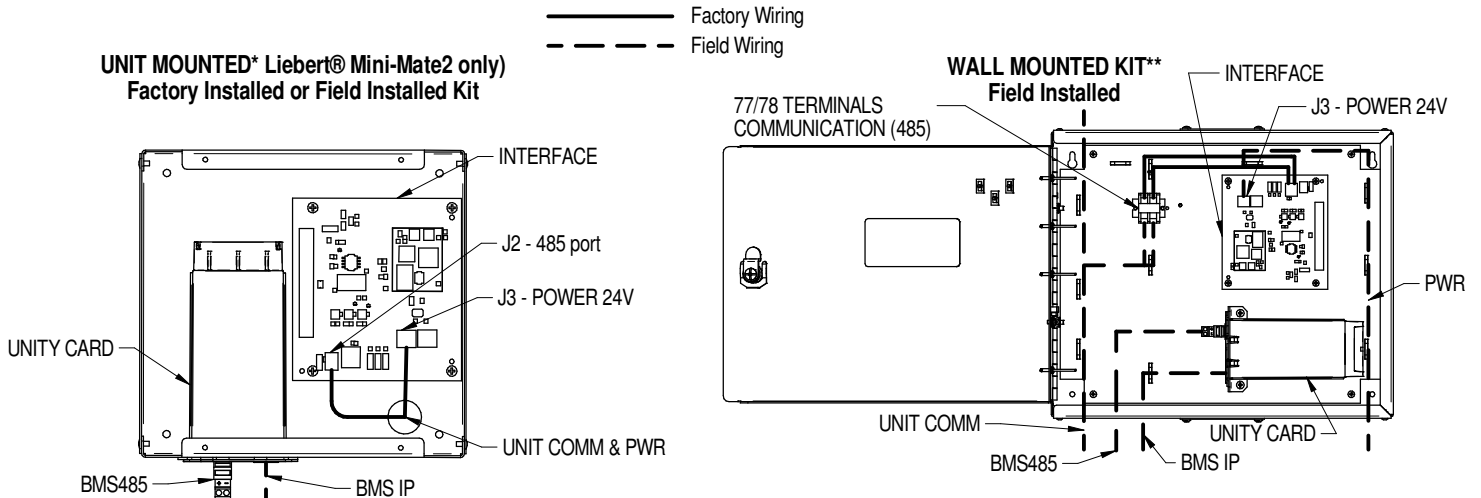



LIEBERT® MINI-MATE2

ELECTRICAL FIELD CONNECTIONS 5 TON AIR COOLED INDOOR CONDENSING MODULE

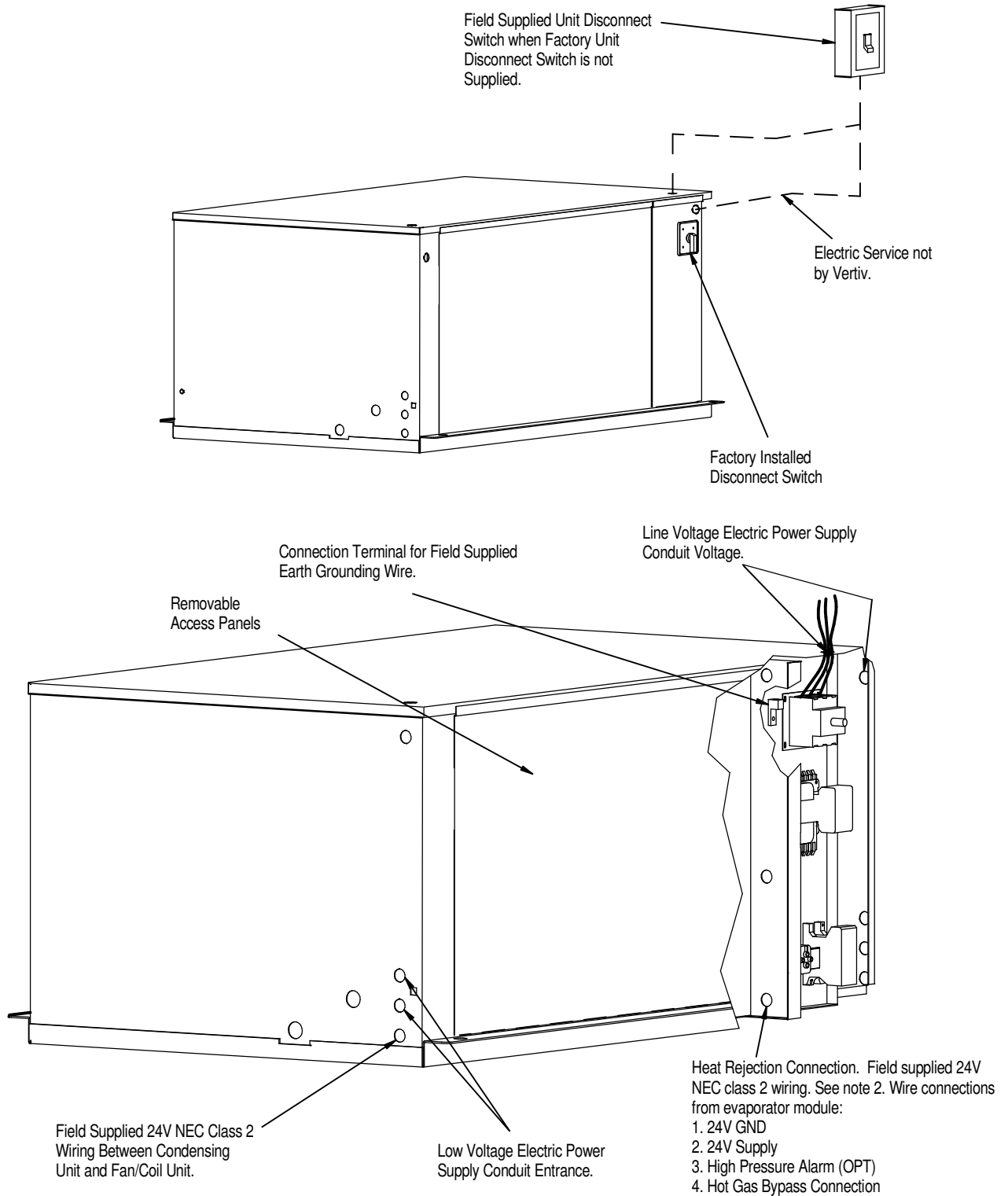

Notes:

1. Refer to specification sheet for full load amp. and wire size amp ratings.
2. Control voltage wiring must be a minimum of 16GA (1.3mm) for up to 75'(23m) or not to exceed 1 volt drop in control line.



LIEBERT® MINI-MATE2

ELECTRICAL FIELD CONNECTIONS 5 TON WATER/GLYCOL COOLED INDOOR CONDENSING MODULE

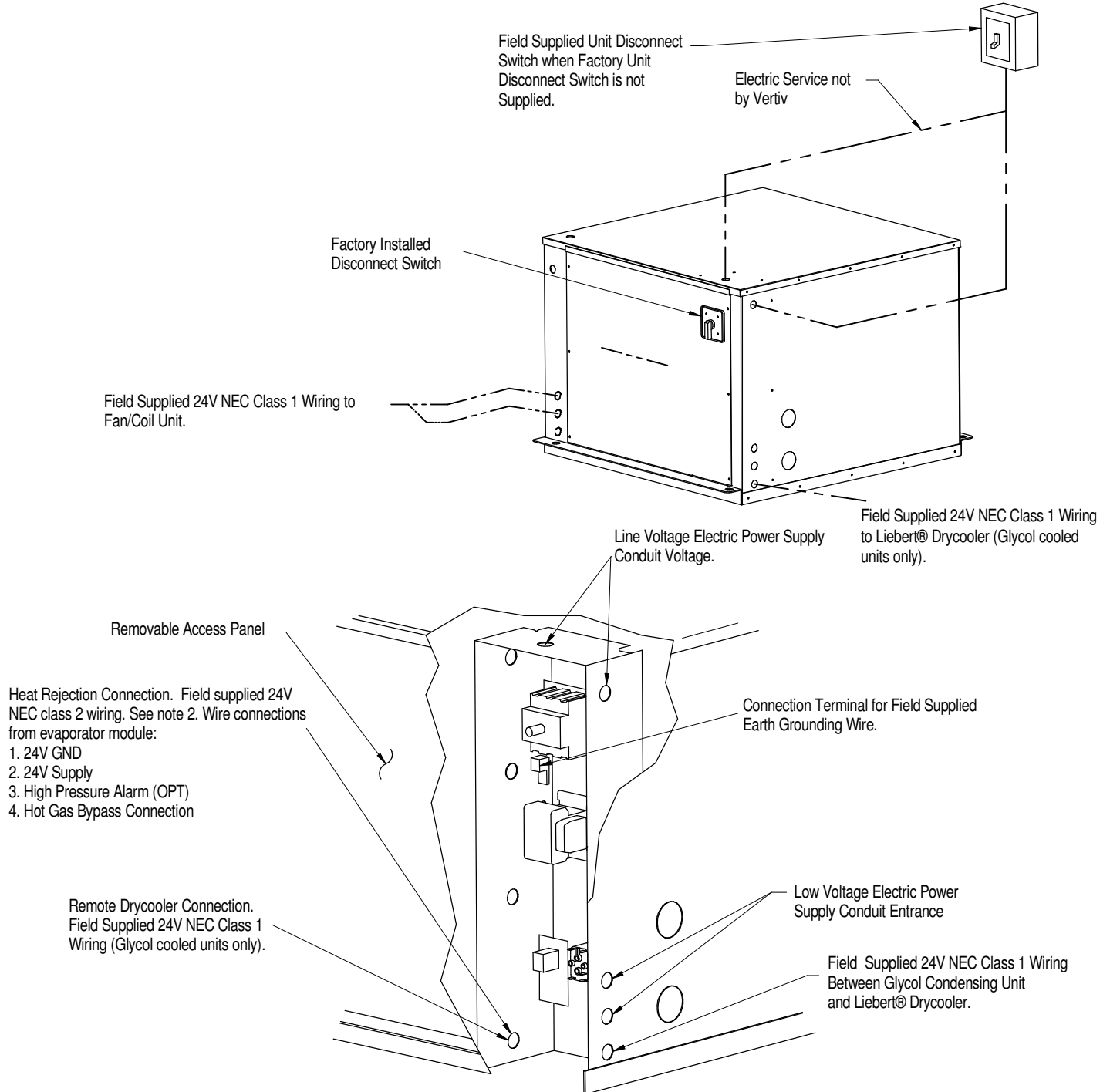

Notes:

1. Refer to specification sheet for full load amp. and wire size amp ratings.
2. Control voltage wiring must be a minimum of 16GA (1.3mm) for up to 75'(23m) or not to exceed 1 volt drop in control line.

This page intentionally left blank

Connect with Vertiv on Social Media



<https://www.facebook.com/vertiv/>



<https://www.instagram.com/vertiv/>



<https://www.linkedin.com/company/vertiv/>



<https://www.twitter.com/Vertiv/>



Vertiv.com | Vertiv Headquarters, 505 N Cleveland Ave, Westerville, OH 43082 USA

©2024 Vertiv Group Corp. All rights reserved. Vertiv™ and the Vertiv logo are trademarks or registered trademarks of Vertiv Group Corp. All other names and logos referred to are trade names, trademarks or registered trademarks of their respective owners. While every precaution has been taken to ensure accuracy and completeness here, Vertiv Group Corp. assumes no responsibility, and disclaims all liability, for damages resulting from use of this information or for any errors or omissions.

SL-10532_REV12_07-24