



# NetSure™ Control Unit (NCU) Retrofit Kit

## User Manual

Kit Specification Number: 60124057

For Use in Spec. No. 582126000 and 581126000 Power System (Main Bay)

Kit Specification Number: 60135833

For Use in Spec. No. 582126000 Power System (Supplemental Bay)

The information contained in this document is subject to change without notice and may not be suitable for all applications. While every precaution has been taken to ensure the accuracy and completeness of this document, Vertiv assumes no responsibility and disclaims all liability for damages resulting from use of this information or for any errors or omissions. Refer to other local practices or building codes as applicable for the correct methods, tools, and materials to be used in performing procedures not specifically described in this document.

The products covered by this instruction manual are manufactured and/or sold by Vertiv. This document is the property of Vertiv and contains confidential and proprietary information owned by Vertiv. Any copying, use or disclosure of it without the written permission of Vertiv is strictly prohibited.

Names of companies and products are trademarks or registered trademarks of the respective companies. Any questions regarding usage of trademark names should be directed to the original manufacturer.

### **Technical Support Site**

If you encounter any installation or operational issues with your product, check the pertinent section of this manual to see if the issue can be resolved by following outlined procedures.

Visit <https://www.vertiv.com/support/> for additional assistance.

## TABLE OF CONTENTS

<b>Admonishments Used in this Document</b> .....	<b>iv</b>
<b>Important Safety Instructions</b> .....	<b>v</b>
Safety Admonishments Definitions.....	v
Safety and Regulatory Statements.....	v
Déclarations de Sécurité et de Réglementation.....	v
<b>1 Description</b> .....	<b>1</b>
<b>2 Bay-to-Bay Communications Cable Connections</b> .....	<b>2</b>
<b>3 Configuring the System</b> .....	<b>10</b>
3.1 NCU Controller Initialization.....	10
3.2 Verifying and Setting the NCU Controller as Required for Your Application.....	11
3.3 Resetting the LVD INHIBIT.....	15
3.4 Programming the Controller for SMDU in the NetSure 701 Supplemental Bays (if present).....	15
3.5 Programming the Controller for SMDU+ in any NetSure 701 Bay (if present).....	15
3.6 Programming the Controller for any NetSure 721/NetSure 7100 Supplemental Bays.....	15
<b>4 External Alarm, Reference, Monitoring, and Control Connections</b> .....	<b>18</b>
4.1 Circuit Card Locations.....	18
4.2 INTERFACE Board.....	19
4.3 LVD Driver Board Connections.....	21
4.4 IB2 (Controller Interface Board) Connections (if required) (Main Bay Only).....	24
4.5 EIB (Controller Extended Interface Board) Connections (if required) (Main Bay Only).....	29
4.6 Optional SM-DU+ and Shunt Interface Board.....	34
4.7 Connecting a Device or System to the Controller's CAN Bus (if required).....	36
4.8 Controller Ethernet Connection (if required).....	36

## Admonishments Used in this Document



**DANGER!** Warns of a hazard the reader **will** be exposed to that will **likely** result in death or serious injury if not avoided. (ANSI, OSHA)



**WARNING!** Warns of a potential hazard the reader **may** be exposed to that **could** result in death or serious injury if not avoided. This admonition is not used for situations that pose a risk only to equipment, software, data, or service. (ANSI)



**CAUTION!** Warns of a potential hazard the reader **may** be exposed to that **could** result in minor or moderate injury if not avoided. (ANSI, OSHA) This admonition is not used for situations that pose a risk only to equipment, data, or service, even if such use appears to be permitted in some of the applicable standards. (OSHA)



**ALERT!** Alerts the reader to an action that **must be avoided** in order to protect equipment, software, data, or service. (ISO)



**ALERT!** Alerts the reader to an action that **must be performed** in order to prevent equipment damage, software corruption, data loss, or service interruption. (ISO)



**FIRE SAFETY!** Informs the reader of fire safety information, reminders, precautions, or policies, or of the locations of fire-fighting and fire-safety equipment. (ISO)



**SAFETY!** Informs the reader of general safety information, reminders, precautions, or policies not related to a particular source of hazard or to fire safety. (ISO, ANSI, OSHA)

# **Important Safety Instructions**

## **Safety Admonishments Definitions**

Definitions of the safety admonishments used in this document are listed under “Admonishments Used in this Document” on page iv.

## **Safety and Regulatory Statements**

Refer to Section 4154 (provided with your customer documentation) for Safety and Regulatory Statements.

## **Déclarations de Sécurité et de Réglementation**

Reportez-vous à la Section 4154 (fourni avec les documents de votre client) pour les déclarations de sécurité et de réglementation.

This page intentionally left blank.

# 1 Description

This document (UM60124057) provides User Instructions for Vertiv™ NetSure™ Control Unit (NCU) Retrofit Kit, Spec. No. 60124057 and Spec. No. 60135833. Refer to the NCU Retrofit Kit Installation Instructions (IM60124057) for installation instructions.

Refer to Table 1.1 for list of additional items for future updates (not included in kit, ordered separately).

**Table 1.1 Additional Items**

Additional Items for future updates (not included in kit, ordered separately)		
P/N	Description	Qty.
10010507	SMDU+ Assembly, External (optional)	1
431300200	1 A In-Line Fuse Pigtail Kit, 3/8" Lug (optional)	1
431300300	1 A In-Line Fuse Pigtail Kit, 5/16" Lug (optional)	1
535135	1 A In-Line Fuse Pigtail Kit, 3/8" Lug and 1/4" Lug (optional)	1
424227900	49.9 Ohm In-Line Resistor Pigtail Kit, 3/8" Lug (optional)	1
424228000	49.9 Ohm In-Line Resistor Pigtail Kit (optional)	1
424228100	49.9 Ohm In-Line Resistor Pigtail Kit, 3/16" (#10) Lug (optional)	1
552992	Temperature Probe Kit, 10.3 Meter (optional)	1
556155	Temperature Probe Kit, 3.3 Meter (optional)	1
547490	SM-Temp Temperature Concentrator (optional) (Also order P/N 562868 and P/N 552888)	1
562868	SM-Temp CAN Bus Interface Cable (optional) (for use with P/N 547490)	1
552888	SM-Temp jumpers (optional) (for use with P/N 547490)	1
02440103	SMIO2 Monitoring Module (optional)	1

Refer to Table 1.2 for list of replacement parts.

**Table 1.2 Replacement Parts**

P/N	Description
1M830BNA	NCU Controller (order with appropriate software configuration)
558076	IB4 Second Ethernet Port Board
SMDU	SM-DU
430001G1	INTERFACE Board
MA4C5U31	IB2 (Controller Interface Board)
MA455U41	EIB (Extended Interface Board)
552822	Temp Probe Sensor
60121401	SM-DU+ assembly
430021G1	LVD Driver Board
430011G1	SHUNT I/O Board

## 2 Bay-to-Bay Communications Cable Connections



**NOTE!** This chapter is only applicable for one or more supplemental bay connections.

The bays are interconnected using standard CAT5 communications cables. Supplemental bays are provided with a 25' cable. Refer to Figure 2.1 for a bay-to-bay cable diagram. A system installed in a relay rack is shown in the illustration. The procedure for a system installed in an enclosure is similar.



**NOTE!** Maximum combined length of the CAT5 communications cables is 328' (100m) per industry standards.

### **Procedure**

1. For each bay in the power system, open the distribution cabinet's front door by turning the latch in the counterclockwise position (system's in a relay rack), or open the system's enclosure door.
2. Remove the terminating plug from the CAN1 OUT connector on the INTERFACE board installed in the Main Bay and place in the RECT\_CAN OUT connector on the INTERFACE board in the last Supplemental Bay.
3. Using a standard CAT5 communications cable (provided with each supplemental bay) connect the CAN1 OUT connector on the INTERFACE board installed in the Main Bay to the SM\_CAN IN connector on the CAN INTERFACE board installed in the 1st Supplemental Bay.
4. Using a standard CAT5 communications cable (provided with each supplemental bay) connect the SM\_CAN OUT connector on the CAN INTERFACE board in the 1st Supplemental Bay to the RECT\_CAN IN connector on the INTERFACE board installed in the 1st Supplemental Bay.
5. Follow the wiring as shown in Figure 2.1 for multiple supplemental bays.



**NOTE!** If the multi-bay plant is equipped with more than forty eight (48) rectifier slots (for 1R483200 or 1R483200E rectifiers) or more than sixty (60) rectifier slots (for 1R483500E rectifiers), connect the CAT5 cable from CAN2 of the main bay to (RECT\_CAN IN) of the bay with the 49th rectifier slot (for 1R483200 or 1R483200E rectifiers) or the bay with the 61st slot (for 1R483500E rectifiers). **CAN1** from Main Bay has to connect to all supplemental bays **SM\_CAN** and will be used for **RECT\_CAN** until the maximum rectifiers have been used. **CAN2** from Main Bay is only used for **RECT\_CAN** after forty eight (48) rectifier slots (for 1R483200 or 1R483200E rectifiers) or after sixty (60) rectifier slots (for 1R483500e rectifiers) have been used. Figure 2.1 shows an example of bay-to-bay CAN connections in which the first 3 bays do not exceed the maximum quantity of rectifiers allowed on CAN 1.

6. For each bay in the power system, close the distribution cabinet's front door and turn the latch clockwise to secure the door (system's in a relay rack) or close the system's enclosure door.



Figure 2.1 Bay-to-Bay Communications Cable Connections (cont'd on next page)

Connector Locations:

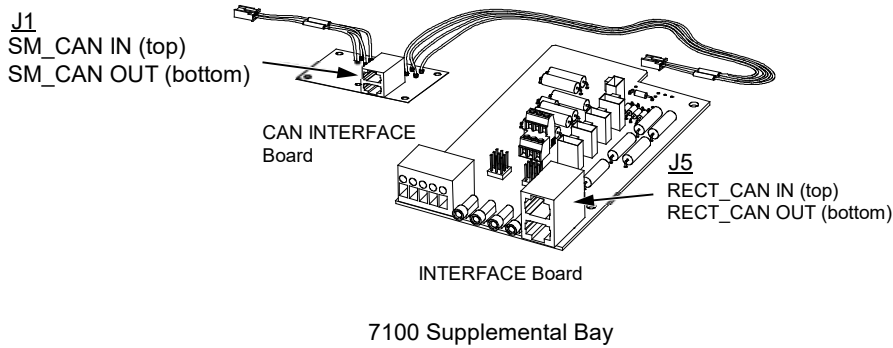
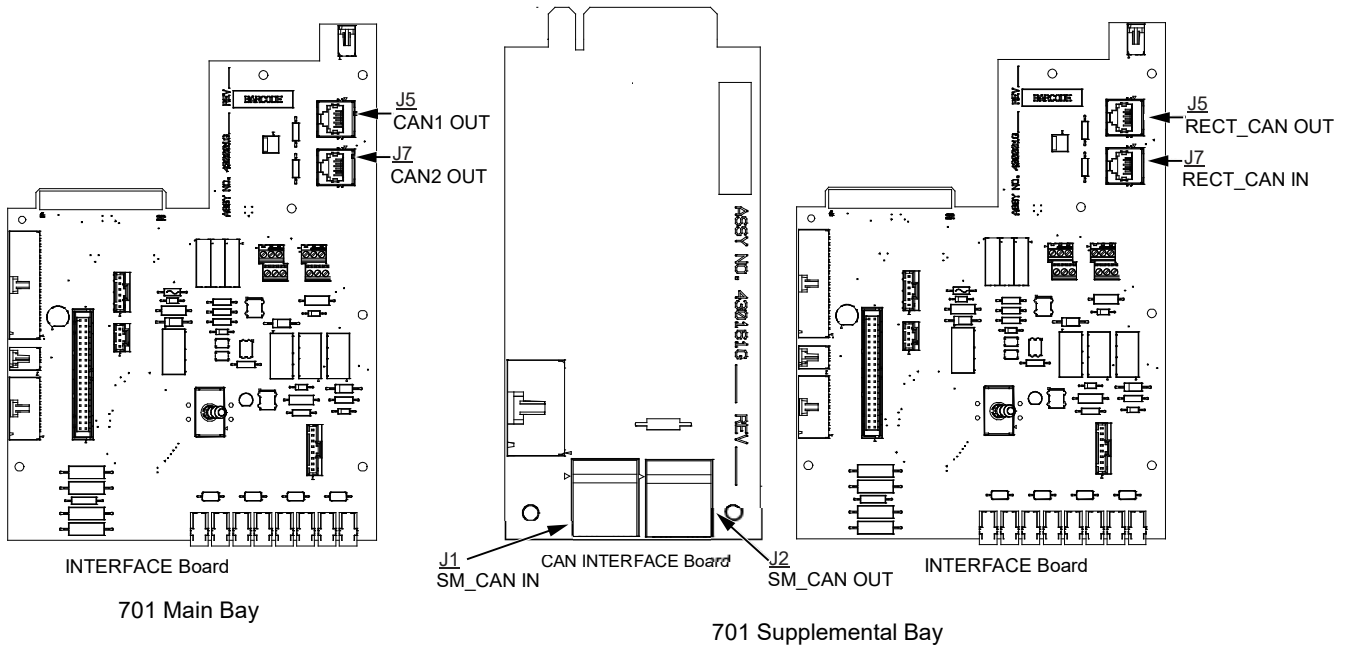
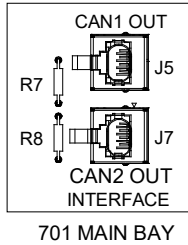

**Figure 2.1 Bay-to-Bay Communications Cable Connections (cont'd on next page)**

Bay-to-Bay Communications Cable Connections with Systems that Have (1) 701 Main Bay and (0 to 5) 7100 Supplemental Bays

- Note: 1. CAN1 will communicate to rectifiers (48 maximum) and SM modules.
- 2. CAN2 will communicate to only rectifiers (48 maximum).

**(1) BAY SYSTEM**



701 MAIN BAY

**(2) BAY SYSTEM**

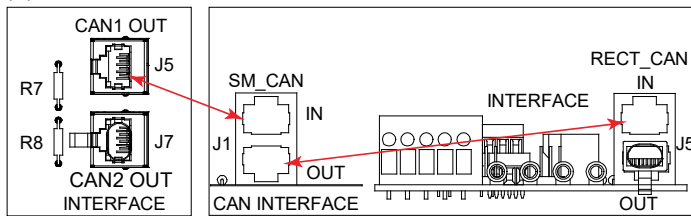

701 MAIN BAY

7100 SUPP BAY #1

**(3) BAY SYSTEM**

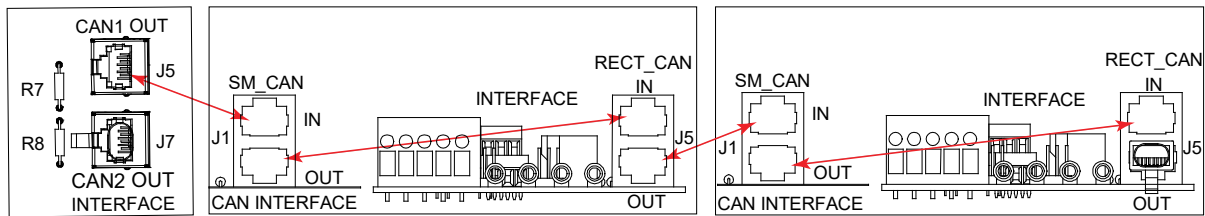

701 MAIN BAY

7100 SUPP BAY #1

7100 SUPP BAY #2

**(4) BAY SYSTEM**

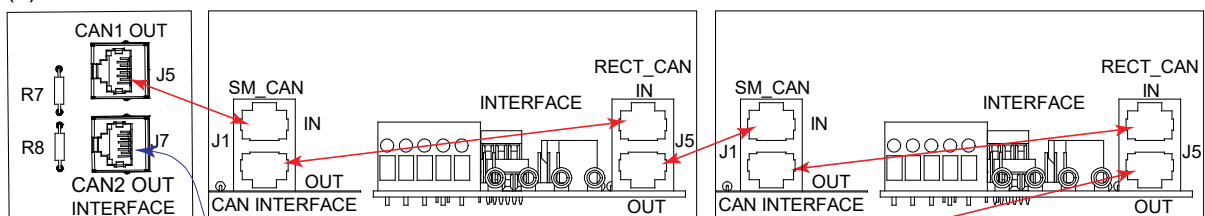

701 MAIN BAY

7100 SUPP BAY #1

7100 SUPP BAY #2

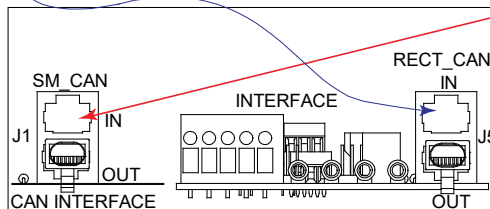

7100 SUPP BAY #3

Figure 2.1 Bay-to-Bay Communications Cable Connections (cont'd on next page)

(5) BAY SYSTEM

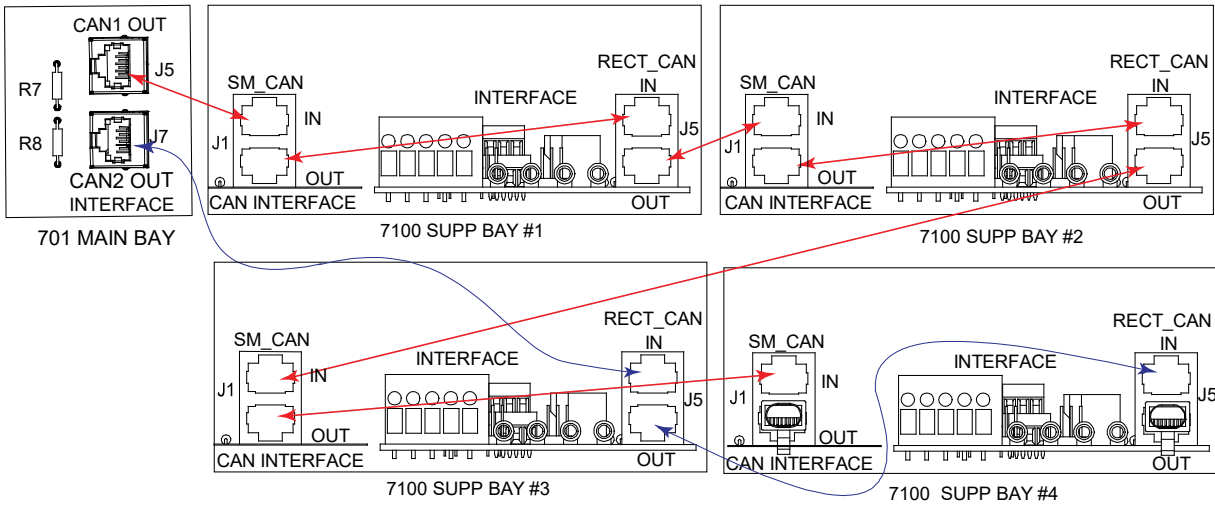

(6) BAY SYSTEM

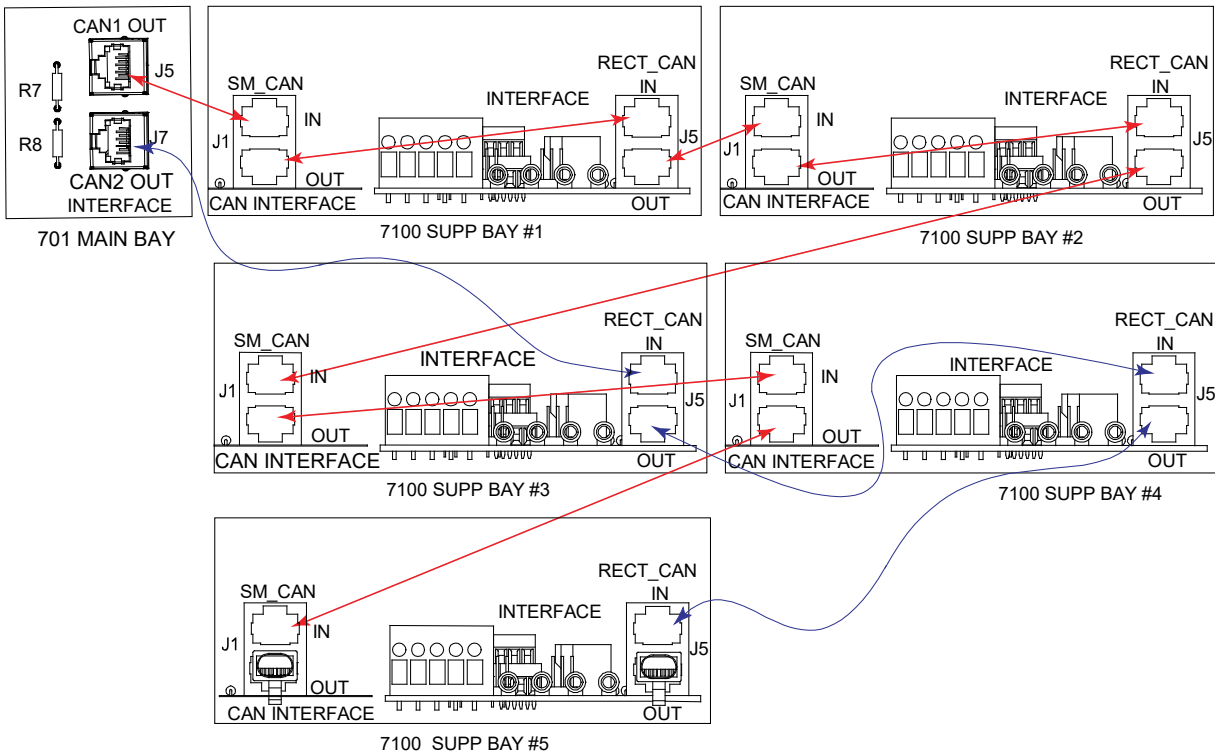

**Figure 2.1 Bay-to-Bay Communications Cable Connections (cont'd on next page)**

Bay-to-Bay Communications Cable Connections with Systems that Have (1) 701 Main Bay, (1) 701 Supplemental Bay and (0 to 4) 7100 Supplemental Bays

Note: 1. CAN1 will communicate to rectifiers (48 maximum) and SM modules.

2. CAN2 will communicate to only rectifiers (48 maximum).

**(2) BAY SYSTEM**

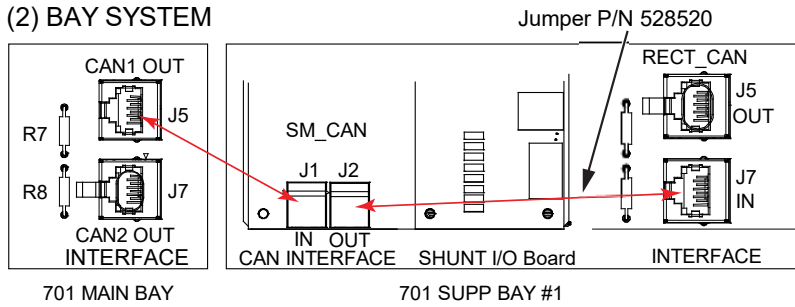

**(3) BAY SYSTEM**

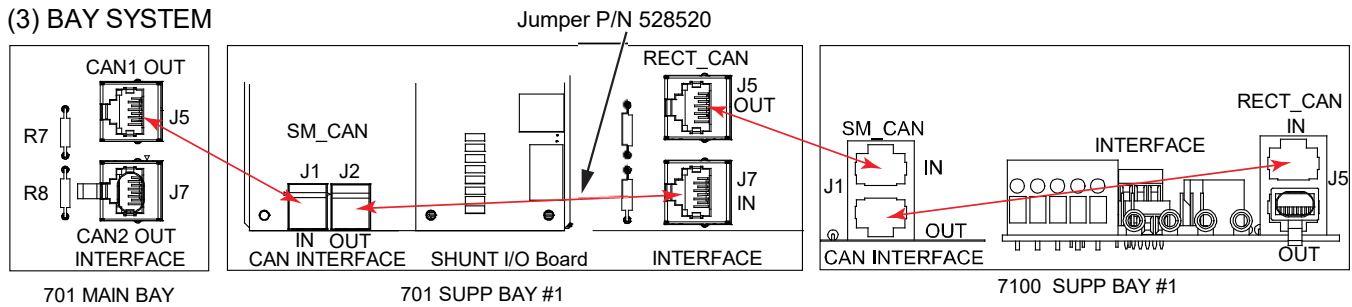

**(4) BAY SYSTEM**

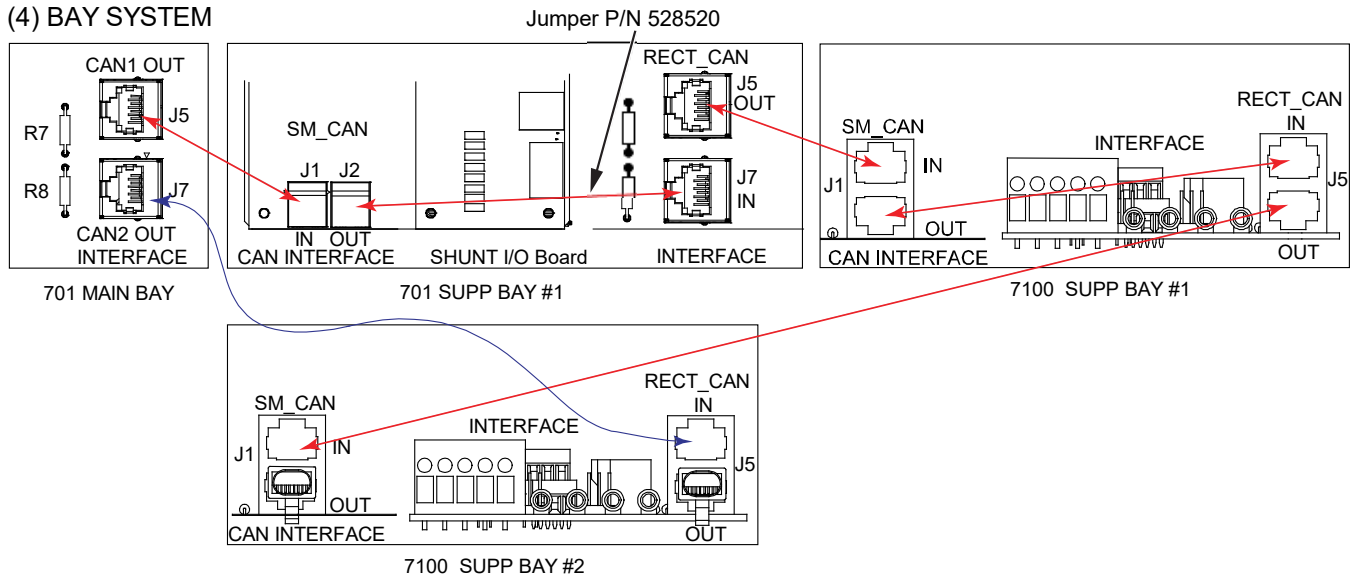
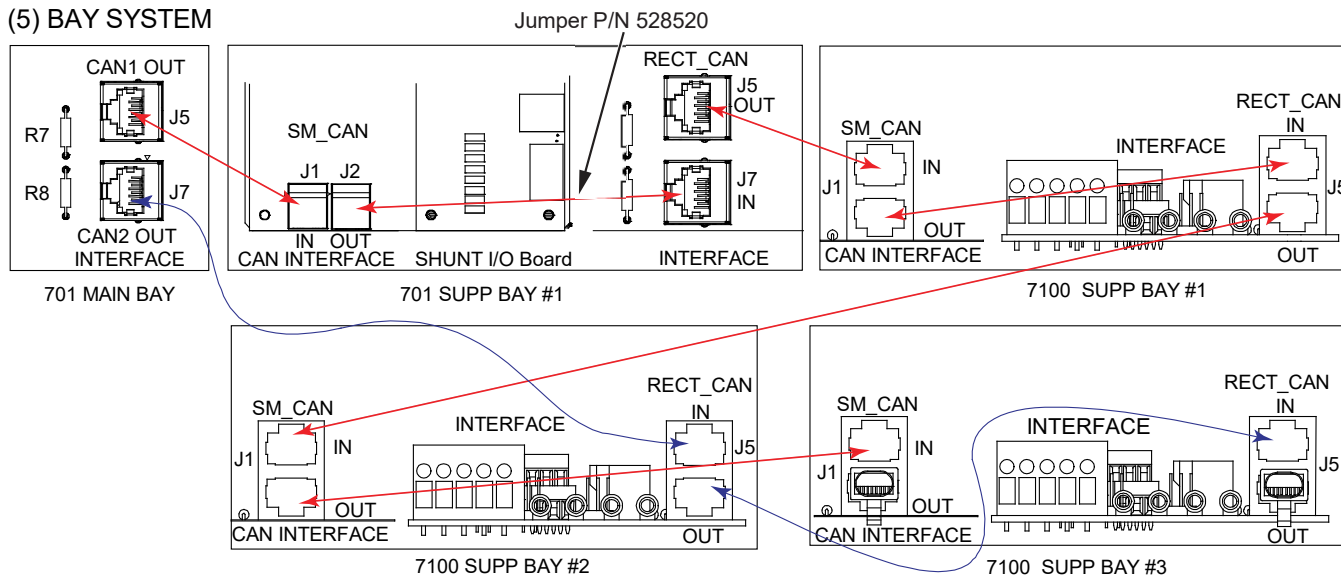
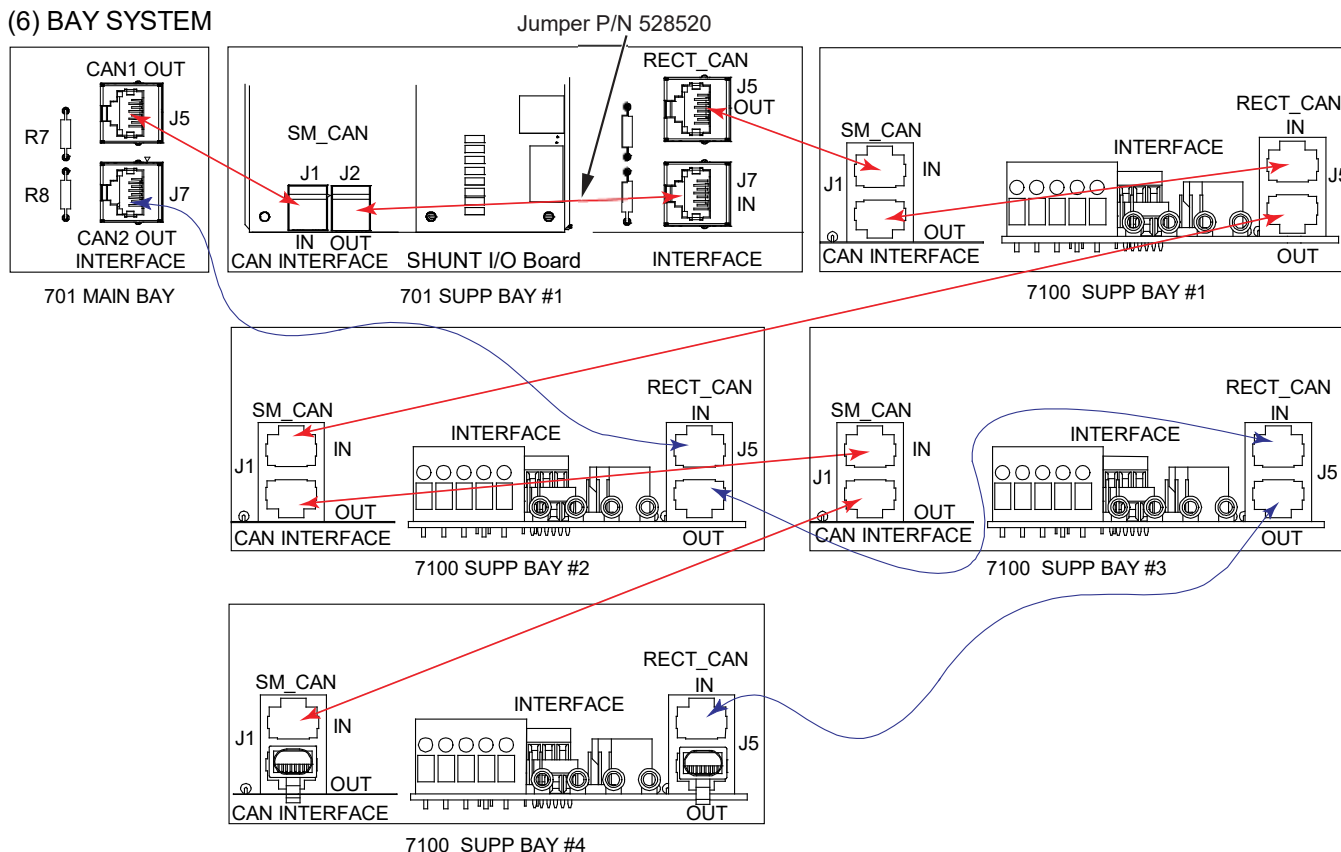

Figure 2.1 Bay-to-Bay Communications Cable Connections (cont'd on next page)

(5) BAY SYSTEM



(6) BAY SYSTEM



**Figure 2.1 Bay-to-Bay Communications Cable Connections (cont'd on next page)**

Bay-to-Bay Communications Cable Connections with Systems that Have (1) 701 Main Bay, (2) 701 Supplemental Bays and (0 to 3) 7100 Supplemental Bays

Note: 1. CAN1 will communicate to rectifiers (48 maximum) and SM modules.

2. CAN2 will communicate to only rectifiers (48 maximum).

**(3) BAY SYSTEM**

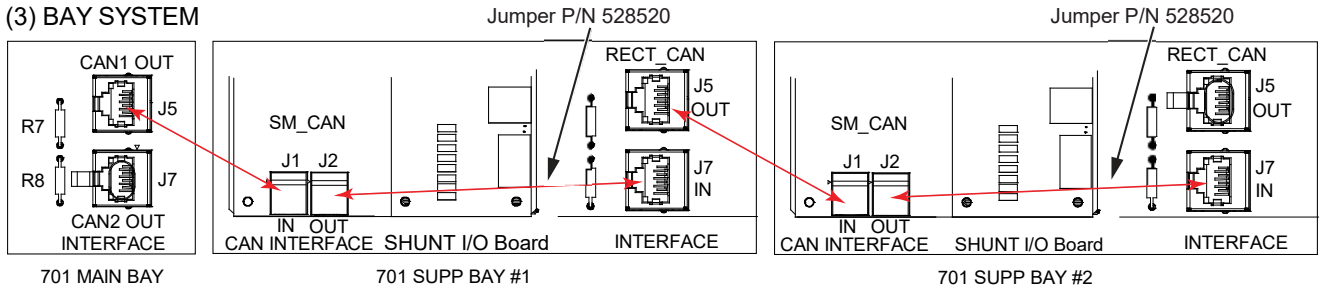

**(4) BAY SYSTEM**

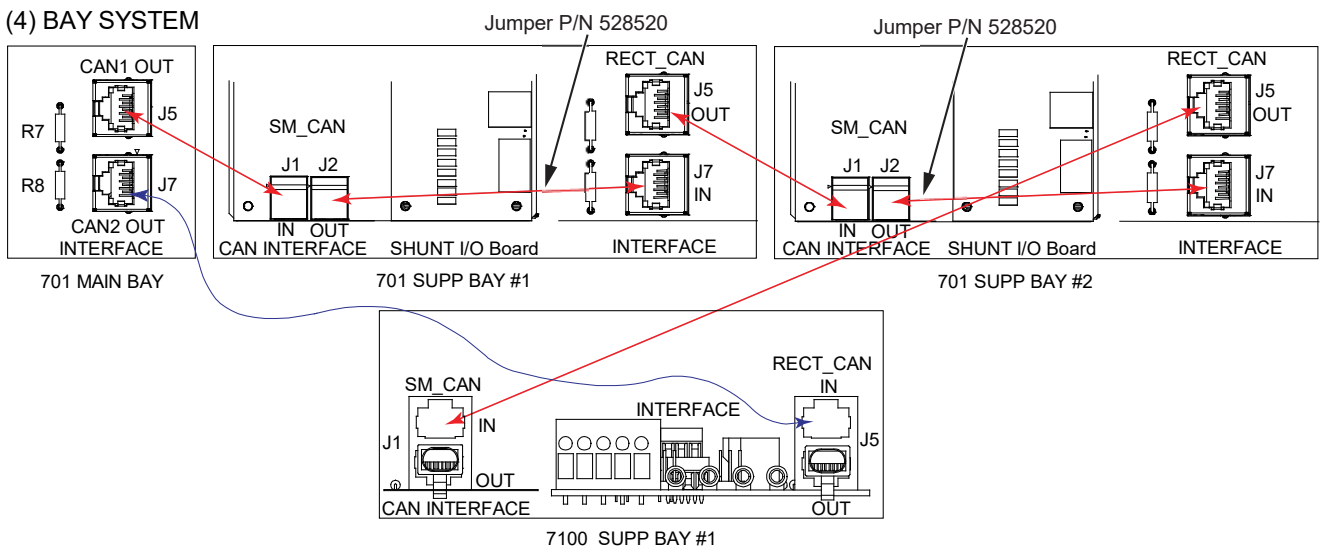
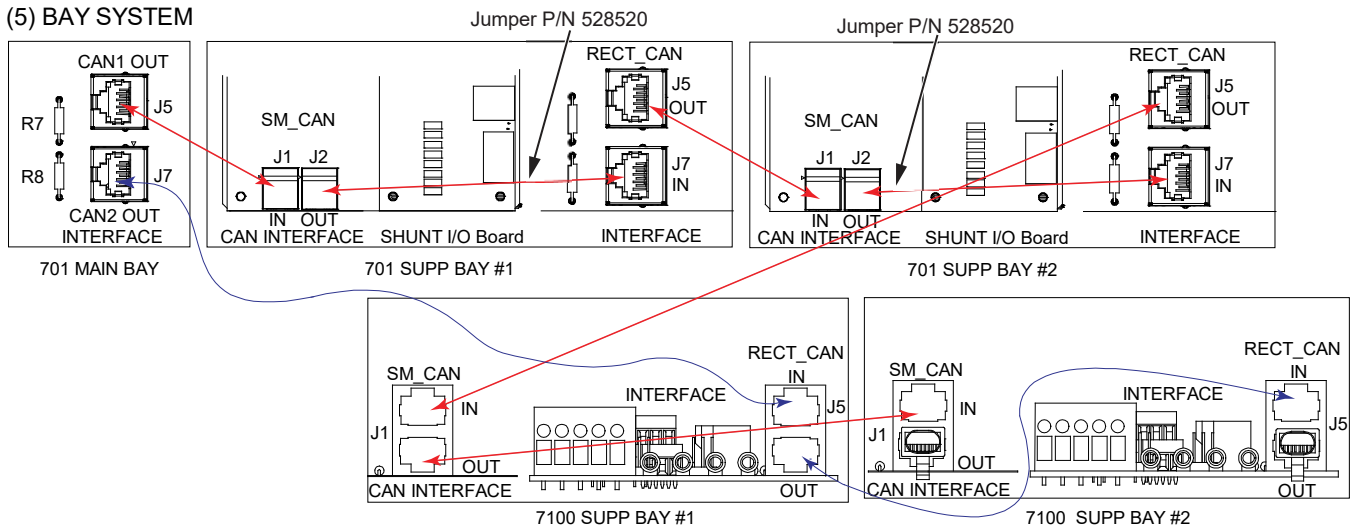
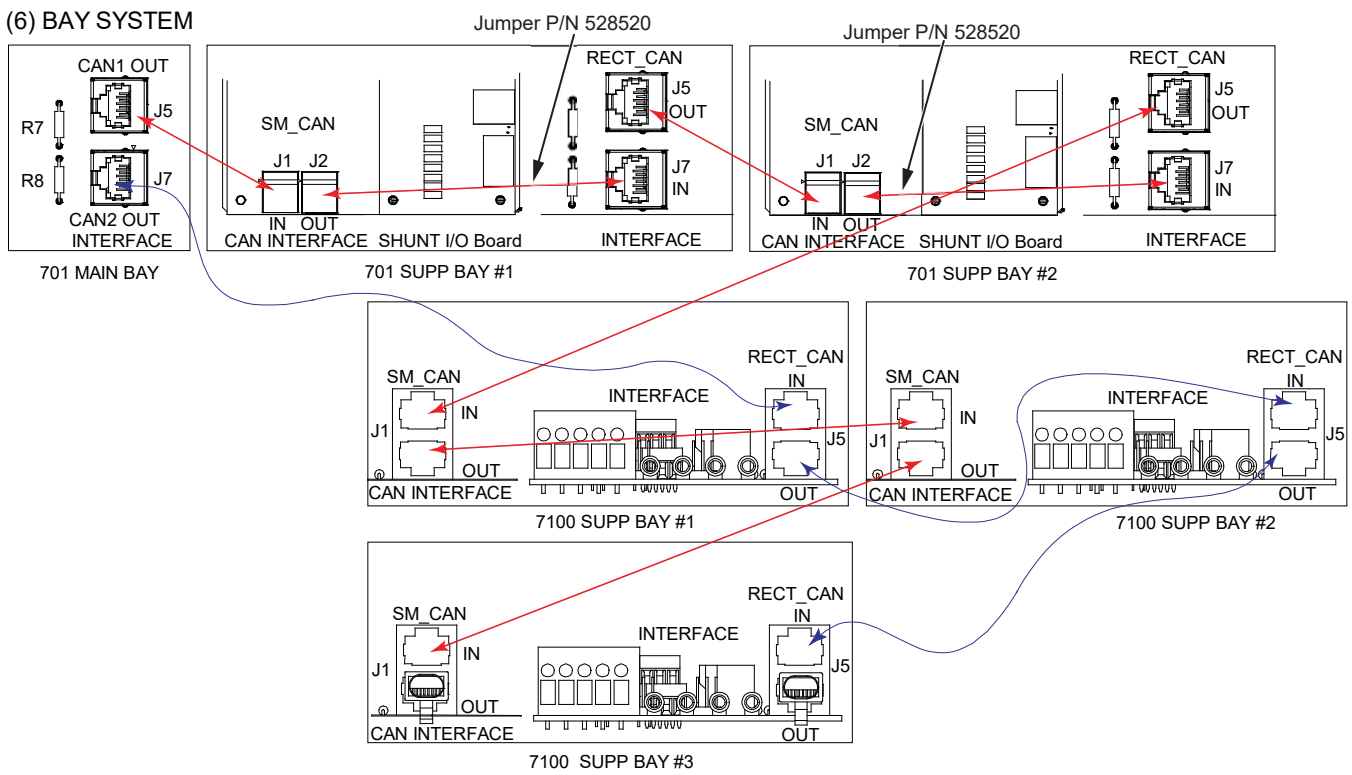

Figure 2.1 Bay-to-Bay Communications Cable Connections (cont'd on next page)

(5) BAY SYSTEM



(6) BAY SYSTEM



## 3 Configuring the System

### 3.1 NCU Controller Initialization

Refer to the NCU Instructions (UM1M830BNA) for detailed instructions.

Refer to Figure 3.1 for locations of the NCU local indicators and navigation keys.

**Figure 3.1 NCU Local Indicators and Navigation Keys**

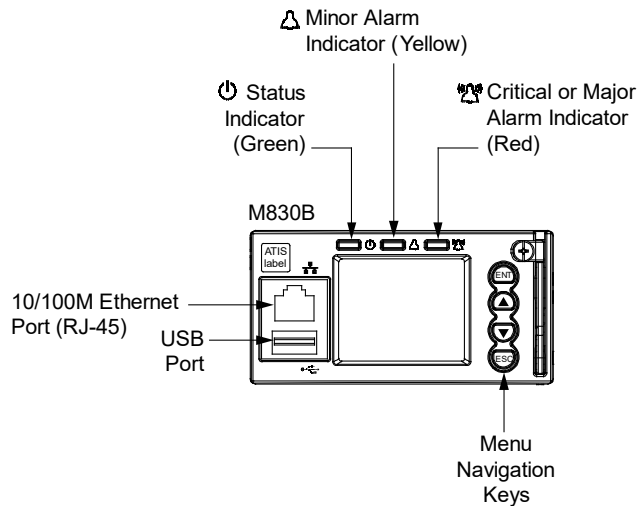

#### Procedure



**NOTE!** The initialization routine takes several minutes. During that time various alarm indicators may illuminate on the NCU front panel and an audible alarm may sound. Disregard all alarms. An audible alarm can be silenced at any time by momentarily depressing any key on the NCU Controller.

1. After the NCU is powered on, the display shows the “logo” screen. The controller is initializing.
2. When initialization is complete, the language screen appears. Press the up or down arrow key to select the desired language. Press the **ENT** key to confirm the selection.
3. The Main Menu displays. See Figure 3.2.



Figure 3.2 NCU Local Display Main Menu

## Main Menu

Date and time are alternately displayed.

Green - No Alarm  
Red - Alarm

The number in ( ) indicates the total number of alarms.

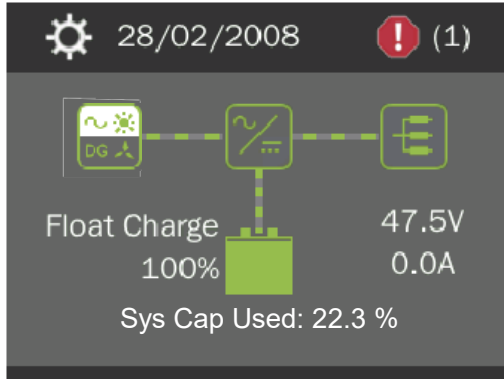

Press the UP and DOWN keys to highlight the desired Menu graphic in the Main Menu.

Press the ENT key to enter the selected menu.

Graphics	Menu Name	Description
	Alarm (Green - No Alarm) (Red - Alarm)	View active alarms and alarm history.
	Settings	Gain access to the NCU Controller's settings menus.
	Input Power	View AC, Solar, DG, and Wind related information.
	Module	View rectifier, solar converter, and converter module related information.
	DC	View DC equipments related information.
	Battery	View battery related information.

To reboot the Controller, from the Main Menu press the ENT and ESC keys at the same time. Release both keys. Press ENT to confirm.



**NOTE!** "Sys Cap Used" is based on the number of installed rectifiers and solar converters (if furnished).

- System information is displayed in multiple screens. Press the ESC key to view other system information. Press the down arrow key to view the next screen. Press the ESC key to return to the Main Menu.
- From the Main Menu, press the UP and DOWN keys to highlight the desired Menu graphic in the Main Menu. Press the ENT key to enter the selected menu.



**NOTE!** Repeatedly press the "ESC" key to return in reverse order level by level from any submenu until the Main Menu appears.

- Refer to the following procedures to verify and set the NCU controller as required for your application.

## 3.2 Verifying and Setting the NCU Controller as Required for Your Application

Refer to the MCA settings recorded at the beginning of the installation procedure. The NCU web interface will be used to make adjustments as needed. Refer to the NCU Instructions (UM1M830BNA) for procedures.

Note that you will have to program the NCU for any temperature probes and external inputs/outputs connected to the IB2 board, optional EIB board, and optional SM-DU+ Shunt Interface Board.

Refer also to "NCU Start Wizard" on page 12.



**NOTE!** When setting total rectifier or total converter current limit, the set point to each unit is the total set point divided by the number of units. For example, if the system contains five rectifiers and the current limit is set to 150 amps then each rectifier has a current limit set point of 30 amps. If one or more rectifiers or converters are removed or fail it will take several seconds for the individual set points to the remaining rectifiers or converters to be reset. In the example given, if one rectifier is removed the current limit set point will drop to 120 amps (30 amps times four remaining rectifiers) until the controller can send updated set points to the remaining rectifiers. This takes a couple communication cycles (several seconds) after which each rectifier would have a new set point of 37.5 amps for a total of 150 amps. The total current limit of the rectifiers and converters should not be set such that the loss of the redundant rectifiers or converters will cause this temporary set point to drop below the actual maximum expected load. If batteries are used on the rectifier output, the batteries should support the load until the current limit set points can be re-established due to loss of a rectifier.

## **NCU Start Wizard**

For initial startup, you can perform the Start Wizard from the local keypad and display to enter basic programmable parameters in one session. Refer to the “Start Wizard” section in the NCU Instructions (UM1M830BNA).

## **Verifying the Configuration File**

Your NCU was programmed with a configuration file that sets all adjustable parameters. The version number of the configuration file can be found on the configuration drawing (C-drawing) that is supplied with your controller documentation, and on a label located on the NCU. You can verify that the correct configuration file has been loaded into your NCU by performing the following procedure.



**NOTE!** The quantity of LVD's and shunt values for your specific system may be different from the values shown on the C-drawing.

### **Procedure**

1. With the Main Menu displayed, press **ESC**. A screen displays the NCU name, serial number, IP number, software version, hardware version, and configuration version number.
2. Press **ESC** to return to the Main Menu.

## **Checking Basic System Settings**

Navigate through the controller menus and submenus to check system settings. You can adjust any parameter as required. Note that these settings can also be checked (and changed if required) via the WEB Interface. Refer also to “NCU Start Wizard” on page 12.



**NOTE!** Repeatedly press the “ESC” key to return in reverse order level by level from any submenu until the Main Menu appears.

### **Procedure**

1. **To Select a Sub-Menu:**  
Press the UP and DOWN keys to highlight the desired sub-menu. Press the ENT key to enter the selected sub-menu.
2. **To Select a User:**  
To select a User, use the UP and DOWN keys to move the cursor to the Select User field. Press ENT. Use the UP and DOWN keys to select a User previously programmed into the NCU. Press ENT to select the User. Note that only Users programmed into the NCU are shown. Users are programmed via the Web Interface. The default User is admin.
3. **To Enter a Password:**  
To enter a password, use the UP and DOWN keys to move the cursor to the Enter Password field. Press ENT. Use the UP and DOWN keys to choose a character. Press ENT to accept and move to the next character. Continue this process until all characters are entered. Press ENT again to accept the password. The default password is 640275.

4. **To Change a Parameter:**  
Press the UP and DOWN keys to move up and down the list of parameters. Press ENT to select the parameter. Press the UP and DOWN keys to change the parameter. Press ENT to make the change. Press ESC to cancel the change.
5. Table 3.1 shows the menu navigation for some basic settings. Refer to the separate NCU Manual (UM1M830BNA) supplied with your power system for complete Local Display menus.



**NOTE!** When a List 5 is cabled to the main battery term bars in the List 1, the battery shunt should be turned off and “Calculate Battery Current” can be turned on.



**NOTE!** If an NCU configuration is furnished that enables NCU capability to receive status information sent from Fiamm SoNick (Sodium Nickel) batteries, some NCU parameters cannot be changed. Refer to the NCU controller manual UM1M830BNA for details.

**Table 3.1 NCU Basic Settings Local Display Menu Navigation**

Parameter	Menu Navigation
Date	Main Menu / Settings Icon / Sys Settings / Date.
Time	Main Menu / Settings Icon / Sys Settings / Time.
IP Communications Parameters (IP address, subnet mask address, gateway address)	Main Menu / Settings Icon / Comm Settings / enter parameters.
Float Voltage	Main Menu / Settings Icon / Batt Settings / Charge / Float Voltage.
Equalize Voltage	Main Menu / Settings Icon / Batt Settings / Charge / EQ Voltage.
Battery Current Limit	Main Menu / Settings Icon / Batt Settings / Charge / Curr Limit Mode and Batt Curr Limit.
Battery Capacity	Main Menu / Settings Icon / Batt Settings / Batt1 Settings or Batt2 Settings / Rated Capacity.
Reset Battery Capacity	Main Menu / Settings Icon / Batt Settings / Basic Settings / Reset Batt Cap
BTRM Feature	<b>Web Menu Navigation Only:</b> Settings Menu / Battery Tab.
Battery Charge Temperature Compensation	Main Menu / Settings Icon / Batt Settings / Temp Comp (enter parameters).
HVSD Limit	<b>Web Menu Navigation Only:</b> Settings Menu / Rectifiers Tab / HVSD (set to enabled) then set HVSD Limit.
Rectifier Current Limit	Main Menu / Settings Icon / Rect Settings / Current Limit (set to enabled) then set Curr Limit Pt.
Over Voltage Alarm 1	Main Menu / Settings Icon / Other Settings / Over Voltage 1.
Over Voltage Alarm 2	Main Menu / Settings Icon / Other Settings / Over Voltage 2.
Under Voltage Alarm 1	Main Menu / Settings Icon / Other Settings / Under Voltage 1.
Under Voltage Alarm 2	Main Menu / Settings Icon / Other Settings / Under Voltage 2.

### **Changing Battery Capacity Rating in the NCU**

1. Change the battery capacity setting of the NCU to match the battery connected to the power system.



**NOTE!** After setting the battery capacity, the User should also reset the battery capacity (battery must be fully charged).

#### **Local Menu Navigation:**

Main Menu / Settings Icon / Batt Settings / Batt1 Settings or Batt2 Settings / Rated Capacity.

#### **Web Menu Navigation:**

Settings Menu / Battery Tab / Batt1 Rated Capacity and Batt2 Rated Capacity.

2. Reset the battery capacity (resets the battery capacity calculation).



**NOTE!** Only reset the battery capacity when the battery is fully charged; otherwise, the battery charge status may not be accurate.

**Local Menu Navigation:**

Main Menu / Settings Icon / Batt Settings / Basic Settings / Reset Batt Cap.

**Web Menu Navigation:**

Settings Menu / Battery Tab / Reset Battery Capacity.

Refer to the NCU Instructions (UM1M830BNA) for detailed instructions.

### **Configuring the NCU Identification of Rectifiers and Assigning which Input Feed is Connected to the Rectifiers**

When rectifiers are all installed prior to applying power and starting the system, the order in which the NCU identifies the rectifiers is by serial number (lowest serial number is Rect 1, next lowest is Rect 2, etc.). If you prefer the NCU to identify the rectifiers by position in the system, perform the following procedure.

Upon power up, the NCU arbitrarily assigns Feed AC1, AC2, or AC3 to each rectifier. This assignment is used to display rectifier AC input feed voltage(s). The User may reassign the feed to each rectifier per your specific installation by following the procedure below.

**Local Menu Navigation:**

None.

**Web Menu Navigation:**

Refer to the NCU Instructions (UM1M830BNA) for detailed instructions.

### **Configuring the NCU Identification of Converters**

When converters are all installed prior to applying power and starting the system, the order in which the NCU identifies the converters is by serial number (lowest serial number is Conv 1, next lowest is Conv 2, etc.). If you prefer the NCU to identify the converters by position in the system, perform the following procedure.

**Local Menu Navigation:**

None.

**Web Menu Navigation:**

Refer to the NCU Instructions (UM1M830BNA) for detailed instructions.

### **NCU Alarm Relay Check**

To verify operation of the external alarm relays, use the NCU alarm relay test feature. Refer to the NCU Instructions (UM1M830BNA) for instructions in using this feature.



**NOTE!** The relays may be preprogrammed for specific functions. Refer to the configuration drawing (C-drawing) supplied with your system for your system's specific configuration.

### 3.3 Resetting the LVD INHIBIT

#### **Procedure**

Ensure that the only alarm(s) present on the NCU is "MAIN LVD INHIBIT" and "SUPP LVD INHIBIT" (if you have a supplemental bay). If there are more alarms present, STOP! and troubleshoot before proceeding.

If no other alarms are present, then check that the two (2) green LEDs on the LVD DRIVER card are illuminated. If either green LED is not illuminated in any 701 bay, STOP! and troubleshoot before proceeding.

If both green LEDs in each 701 retrofitted bay are illuminated, place the INHIBIT switch on the INTERFACE board to the "Normal" position and verify the yellow LED next to the switch turns off.

Verify the alarms on the NCU clear. You should have no alarms present on the NCU.

### 3.4 Programming the Controller for SMDU in the NetSure 701 Supplemental Bays (if present)

#### **Procedure**

The NCU is pre-programmed to have LVD1 and LVD2 enabled. If one or both LVDs are not installed in the system, then you must disable the LVD. Refer to the NCU Instructions (UM1M830BNA) for programming details.

Once the controller has been programmed and you have no further settings to make, refer to the NCU Instructions (UM1M830BNA) and save a copy of the "SettingParam.tar" file.

### 3.5 Programming the Controller for SMDU+ in any NetSure 701 Bay (if present)

Any shunts connected to the SMDU+ will need to be programmed in the NCU. Refer to the NCU Instructions (UM1M830BNA) for programming details.

Once the controller has been programmed and you have no further setting to make, refer to the NCU Instructions (UM1M830BNA) and save a copy of the "SettingParam.tar" file.

### 3.6 Programming the Controller for any NetSure 721/NetSure 7100 Supplemental Bays

#### **Procedure**

Supplied with the NetSure 721/NetSure 7100 supplemental bay is a USB drive which contains the product documentation along with a document file that provides a listing of the SM-DU and optional SM-DU+ settings required for that particular supplemental bay. See Table 3.2 and Table 3.3 for samples of the information provided in the file. Refer to this document file (chart) and program the SM-DU and optional (if furnished) SM-DU+ settings in the controller with the specific values listed in the chart. Refer to the NCU Instructions (UM1M830BNA) for programming details. There are also labels located near the SM-DU and SM-DU+ in the supplemental bay that detail the controller's settings for this bay.

Once the controller has been programmed for the newly installed supplemental bay, refer to the NCU Instructions (UM1M830BNA) and save a copy of the "SettingParam.tar" file.

**Table 3.2 Sample Supplemental Bay SM-DU Programmable Parameter Chart**

Device	Parameter	Factory Setting	Setting for this Bay
SM-DU Shunt 1 Load	Full Scale Current (A)	2500	Refer to USB Drive
	Full Scale Voltage (mV)	25	Refer to USB Drive
SM-DU Shunt 2 Battery	Full Scale Current (A)	2500	Refer to USB Drive
	Full Scale Voltage (mV)	25	Refer to USB Drive
SM-DU LVD	LVD1	Enabled	Refer to USB Drive
	LVD2	Enabled	Refer to USB Drive

**Table 3.3 Sample Supplemental Bay Optional SM-DU+ Programmable Parameter Chart (cont'd on next page)**

Device	Parameter	Factory Setting	Setting for this Bay
SM-DU+ Shunt 1	Full Scale Current (A)	500	Refer to USB Drive
	Full Scale Voltage (mV)	25	Refer to USB Drive
SM-DU+ Shunt 2	Full Scale Current (A)	500	Refer to USB Drive
	Full Scale Voltage (mV)	25	Refer to USB Drive
SM-DU+ Shunt 3	Full Scale Current (A)	500	Refer to USB Drive
	Full Scale Voltage (mV)	25	Refer to USB Drive
SM-DU+ Shunt 4	Full Scale Current (A)	500	Refer to USB Drive
	Full Scale Voltage (mV)	25	Refer to USB Drive
SM-DU+ Shunt 5	Full Scale Current (A)	500	Refer to USB Drive
	Full Scale Voltage (mV)	25	Refer to USB Drive
SM-DU+ Shunt 6	Full Scale Current (A)	500	Refer to USB Drive
	Full Scale Voltage (mV)	25	Refer to USB Drive
SM-DU+ Shunt 7	Full Scale Current (A)	500	Refer to USB Drive
	Full Scale Voltage (mV)	25	Refer to USB Drive
SM-DU+ Shunt 8	Full Scale Current (A)	500	Refer to USB Drive
	Full Scale Voltage (mV)	25	Refer to USB Drive
SM-DU+ Shunt 9	Full Scale Current (A)	500	Refer to USB Drive
	Full Scale Voltage (mV)	25	Refer to USB Drive
SM-DU+ Shunt 10	Full Scale Current (A)	500	Refer to USB Drive
	Full Scale Voltage (mV)	25	Refer to USB Drive
SM-DU+ Shunt 11	Full Scale Current (A)	500	Refer to USB Drive
	Full Scale Voltage (mV)	25	Refer to USB Drive
SM-DU+ Shunt 12	Full Scale Current (A)	500	Refer to USB Drive
	Full Scale Voltage (mV)	25	Refer to USB Drive
SM-DU+ Shunt 13	Full Scale Current (A)	500	Refer to USB Drive
	Full Scale Voltage (mV)	25	Refer to USB Drive
SM-DU+ Shunt 14	Full Scale Current (A)	500	Refer to USB Drive
	Full Scale Voltage (mV)	25	Refer to USB Drive
SM-DU+ Shunt 15	Full Scale Current (A)	500	Refer to USB Drive
	Full Scale Voltage (mV)	25	Refer to USB Drive

**Table 3.3 Sample Supplemental Bay Optional SM-DU+ Programmable Parameter Chart (cont'd from previous page)**

Device	Parameter	Factory Setting	Setting for this Bay
SM-DU+ Shunt 16	Full Scale Current (A)	500	Refer to USB Drive
	Full Scale Voltage (mV)	25	Refer to USB Drive
SM-DU+ Shunt 17	Full Scale Current (A)	500	Refer to USB Drive
	Full Scale Voltage (mV)	25	Refer to USB Drive
SM-DU+ Shunt 18	Full Scale Current (A)	500	Refer to USB Drive
	Full Scale Voltage (mV)	25	Refer to USB Drive
SM-DU+ Shunt 19	Full Scale Current (A)	500	Refer to USB Drive
	Full Scale Voltage (mV)	25	Refer to USB Drive
SM-DU+ Shunt 20	Full Scale Current (A)	500	Refer to USB Drive
	Full Scale Voltage (mV)	25	Refer to USB Drive
SM-DU+ Shunt 21	Full Scale Current (A)	500	Refer to USB Drive
	Full Scale Voltage (mV)	25	Refer to USB Drive
SM-DU+ Shunt 22	Full Scale Current (A)	500	Refer to USB Drive
	Full Scale Voltage (mV)	25	Refer to USB Drive
SM-DU+ Shunt 23	Full Scale Current (A)	500	Refer to USB Drive
	Full Scale Voltage (mV)	25	Refer to USB Drive
SM-DU+ Shunt 24	Full Scale Current (A)	500	Refer to USB Drive
	Full Scale Voltage (mV)	25	Refer to USB Drive
SM-DU+ Shunt 25	Full Scale Current (A)	500	Refer to USB Drive
	Full Scale Voltage (mV)	25	Refer to USB Drive

## 4 External Alarm, Reference, Monitoring, and Control Connections

### 4.1 Circuit Card Locations

Refer to Figure 4.1 and Figure 4.2.

Figure 4.1 Circuit Card Locations (Main Bay)

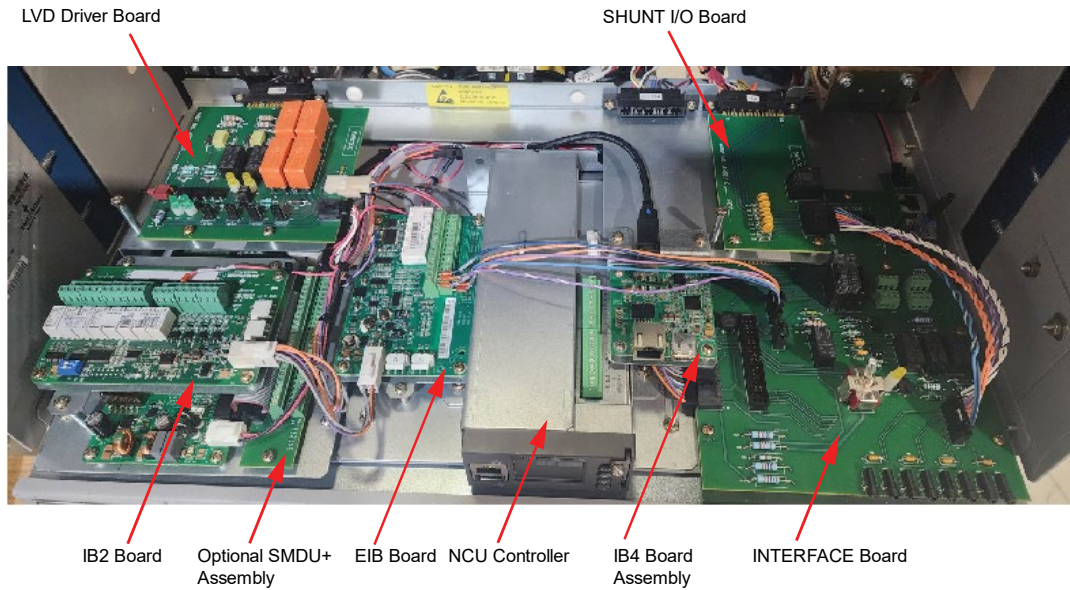
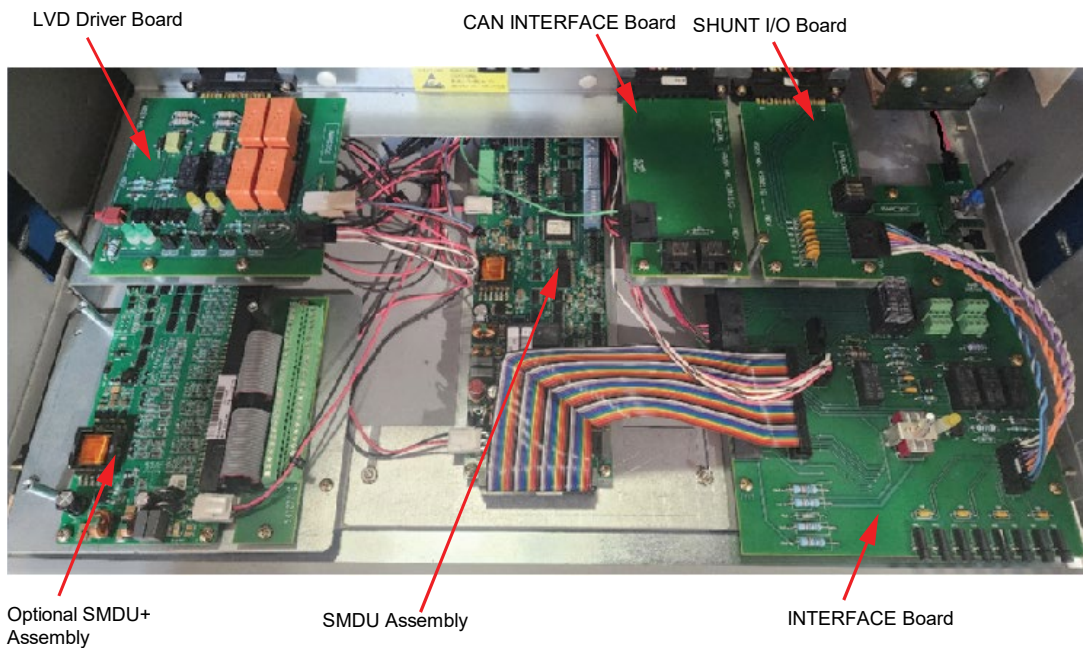

Figure 4.2 Circuit Card Locations (Supplemental Bay)





## 4.2 INTERFACE Board

The INTERFACE board provides connections for the following. Refer to Figure 4.3 and Figure 2.1.

- External Battery FA Signal: This input is used to provide an external battery fuse alarm (FA) on the controller due to a tripped battery disconnect device (fuse, breaker or contactor) external to the power system rack. Application of system voltage to pin TB2 1B activates this alarm. The lead should be protected at the source with an in-line fusible resistor. The source for this lead should be originated from the system side of the disconnect device, not the battery side.
- External System FA Signal: This input is used to provide an external system fuse alarm (FA) on the controller due to a tripped distribution device (fuse or breaker) on the system output external to the power system distribution cabinet. Application of system voltage to pin TB2 1A activates this alarm. The lead should be protected at the source with an in-line fusible resistor. This input is not to be used for any voltage bus (such as converter output) other than the system bus.
- RS485 1A & 2A (Southbound) and RS485 1B & 2B (Northbound) (used for communication with SM modules) (Main Bay Only)  
  
(Also used when an NCU configuration is furnished that enables NCU capability to receive status information sent from Fiamm SoNick [Sodium Nickel] batteries. Connect leads from the Fiamm SoNick batteries to the RS-485 terminals. See Figure 4.3. Refer to the battery manufacturer documentation and the NCU controller manual UM1M830BNA for details.)
- Bay Load Shunt Monitoring Test Points: Provide for measurement of the system load shunt for each distribution row in the bay. Shunts are rated 800A/50mV. The leads are protected against fault.
- Three (3) Axillary fuses (TB1) are provided to be used as needed. Each fuse can be a maximum of 3A.

Figure 4.3 INTERFACE Board Connections

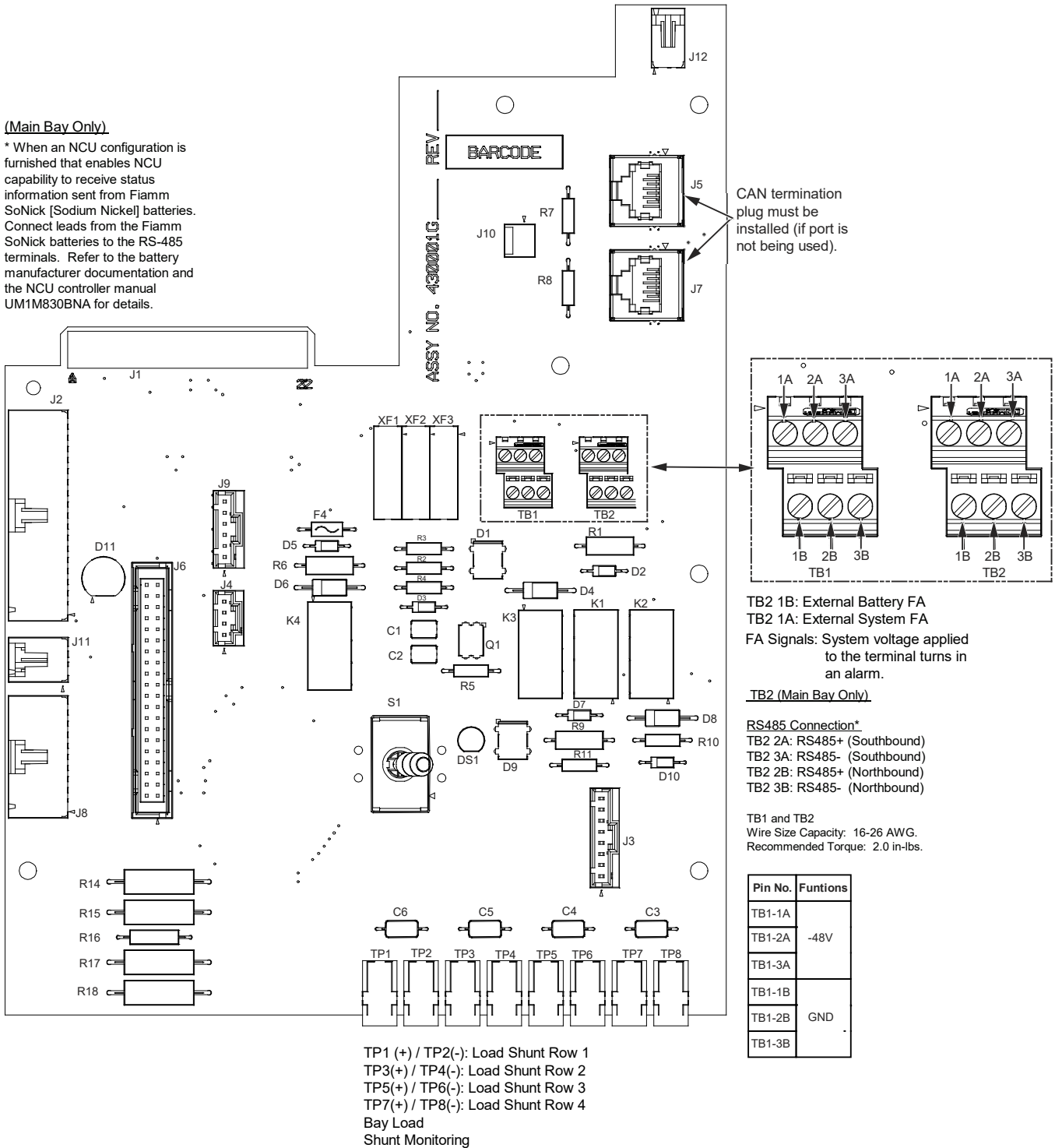

NOTE:  
 See Figure 2.1 for Bay to Bay Communication Cable Connections.

## 4.3 LVD Driver Board Connections

The LVD driver board provides selections for the following. Refer to Figure 4.4.

- J8 is used to select the voltage of the system.
- J3-J6 are used to set the LVD level as set up via the NCU controller for each contactor in the system. J3 is for the LVD in Row 1, J4 is for the LVD in Row 2, J5 is for the LVD in Row 3 and J6 is for the LVD in Row 4. The NCU provides two (2) LVD levels (LV1 and LV2), the settings of which include low voltage disconnect and reconnect thresholds.

Figure 4.4 LVD Driver Board Connections

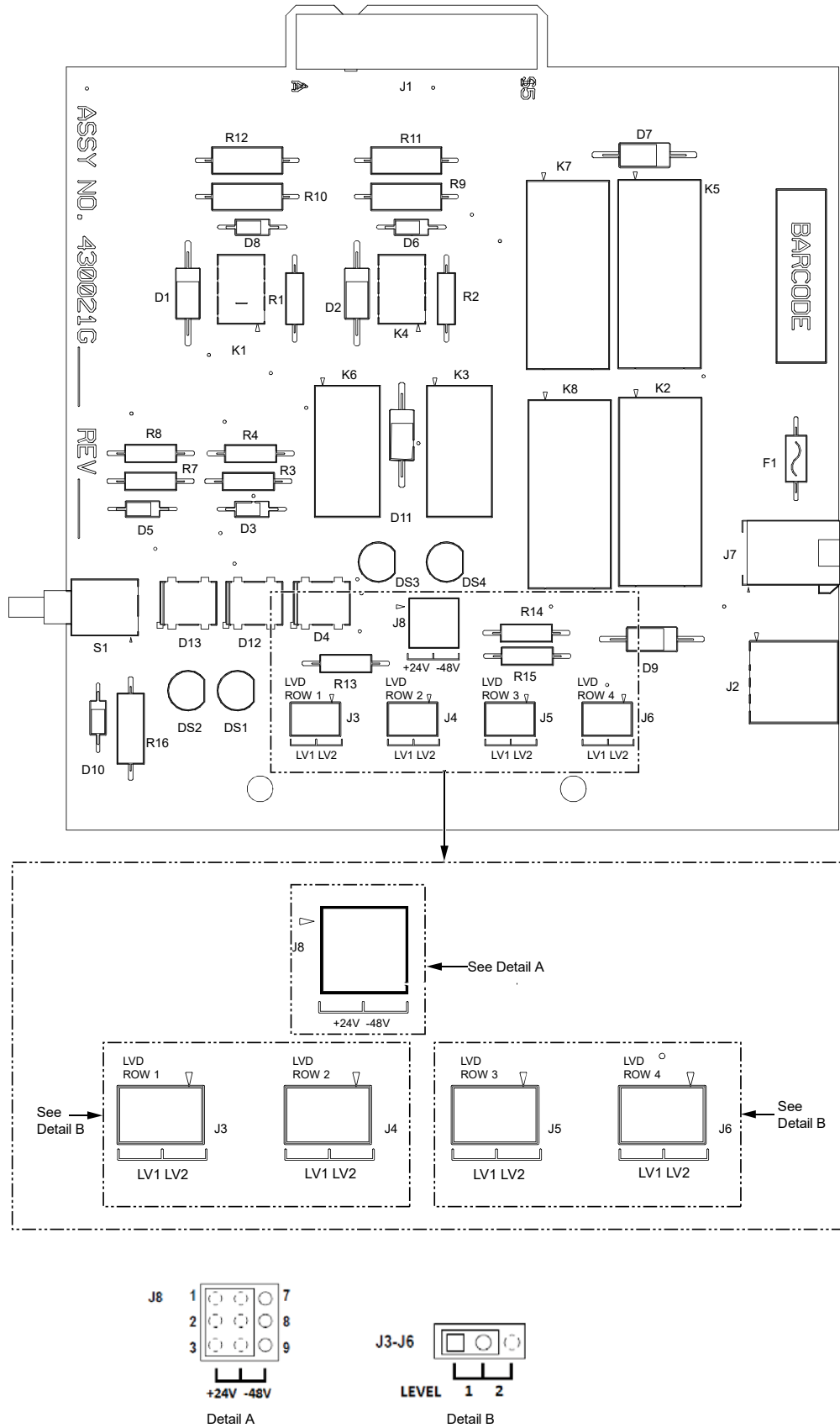

Table 4.1 LED Indicators on the LVD Driver Board

Indicator	System Type	Corresponding LED Location	Normal State (after LVD board installation)	Fault State (applies only during LVD board installation)	Fault Cause
Operation (Yellow)	+24V	DS4 (left side LED only)	ON (with the selector switch set in the +24V position)	OFF	The selector switch is not set to match the system voltage.
					The J8 connector is not plugged in properly.
	-48V	DS3 (right side LED only)	ON (with the selector switch set in the -48V position)	OFF	Power failure (check the input voltage is present).
					Faulty LVD driver board (replace the board).
Power (Green)	Both (+24V and -48V)	DS1	ON (LVD1 has voltage applied)	OFF (LVD1 has no voltage being applied)	Faulty LVD driver board (replace the board).
		DS2	ON (LVD2 has voltage applied)	OFF (LVD2 has no voltage being applied)	
Note: Green LEDs are used for installation purposes to tell you when LVD1 and LVD2 are applying voltage to the contactors. This does not mean the contactors are energized.					

## 4.4 IB2 (Controller Interface Board) Connections (if required) (Main Bay Only)



**NOTE!** The system includes one (1) IB2 board.



**NOTE!** The alarm relay wiring previously disconnected (if applicable) will be reconnected to the IB2 card and/or EIB card provided with the retrofit.

The IB2 board provides connection points for digital inputs, programmable relay outputs, and temperature probes.

### **Digital Inputs and Programmable Relay Outputs**

Digital input and relay output leads are connected to screw-type terminal blocks located on IB2. Recommended torque for these connections is 2.2 in-lbs. Refer to Figure 4.5 for terminal locations. Refer to Table 4.2 and Table 4.3 for pin-out information.

#### **Digital Inputs**

Connect up to eight (8) digital inputs to IB2. Note that you must supply both paths for the digital input (either a positive or negative signal and the opposite polarity return path). Observe proper polarity. Refer to Figure 4.5 for terminal locations and Table 4.2 for pin-out information.



**NOTE!** For the NetSure 701 system, -48V is factory wired to the Digital Input #8 (-) terminal for your convenience and function predefined for ESTOP. Customer-furnished system return (0V potential) applied to terminal Digital Input #8 (+) activates the ESTOP function.



**NOTE!** For the NetSure 700 system, +24V is factory wired to the Digital Input #8 (+) terminal for your convenience and function predefined for ESTOP. Customer-furnished system return (0V potential) applied to terminal Digital Input #8 (-) activates the ESTOP function.

The digital inputs can be programmed to provide an alarm when the signal is applied (HIGH) or removed (LOW). Refer to the NCU Instructions (UM1M830BNA) for programming information.

Digital Input Ratings: Refer to the following.

- a) Maximum Voltage Rating: 60V DC.
- a) Active High: > 19V DC.
- b) Active Low: < 1V DC.

The digital inputs may be preprogrammed for specific functions. Refer to the configuration drawing (C-drawing) supplied with your system for your system's specific configuration.

### **Power System ESTOP Function**

The ESTOP function shuts down and locks out the rectifiers, shuts down and locks out the optional converters, and opens the optional low voltage disconnect (LVD) contactors (battery and load type). If the system has battery connected and does not contain a battery LVD or the controller power option is set to Battery Pwr (jumper J8 on the INTERFACE board is set to Battery Pwr), the controller will remain operational. If the system does not contain battery or load LVD(s) and has battery connected, the loads will be sustained by the battery voltage.

For Systems NOT Containing a Battery LVD: When the ESTOP signal is removed, LVD contactors (battery and load type) will close after the "LVD Reconnect Delay" has elapsed (customer configurable via the controller) if battery voltage is present on the bus. Rectifiers and optional converters will remain off. The rectifiers will restart when the input power is removed and restored after 30 seconds or more (until the LEDs on the modules extinguish). To restart the converters: remove the converter, wait 30 seconds or more (until the LEDs on the converter extinguish), then re-insert the converter.

For Systems Containing a Battery LVD: When the ESTOP signal is removed, LVD contactors (battery and load type) will remain open. Rectifiers and optional converters will remain off. The rectifiers will restart when the input power is removed and restored after 30 seconds or more (until the LEDs on the modules extinguish). When the rectifiers restart, LVD contactors (battery and load type) will close, and the converters will restart.



**NOTE!** *If a customer-furnished method to disconnect the input power to the system is not provided, the rectifiers will stay locked OFF until the input power is recycled. If the ESTOP signal is removed without recycling the input power, the rectifiers will remain off and have a local alarm visible on the module. The ESTOP alarm from the controller will extinguish. The controller will not issue an alarm for this condition.*

### **Programmable Relay Outputs**

The IB2 provides eight (8) programmable alarm relays with dry Form-C contacts. Connect up to eight (8) relay outputs to IB2. Refer to Figure 4.5 for terminal locations and Table 4.3 for pin-out information.



**NOTE!** *The relay assigned to “Critical Summary” alarm (Relay 1 on first IB2 by default) will operate in the “Fail Safe Mode”. “Fail Safe Mode” means Relay 1 is de-energized during an alarm condition, opening the contacts between the C and NO terminals, and closing the contacts between the C and NC terminals.*

The remaining 7 relays energize during an alarm condition, closing the contacts between the C and NO terminals, and opening the contacts between the C and NC terminals.

Refer to the NCU Instructions (UM1M830BNA) for programming information.

Relay Ratings: Refer to the following:

- a) Steady State : 0.5A @ 60V DC; 1.0A @ 30V DC.
- b) Peak : 3A @ 30V DC.

The relays may be preprogrammed for specific functions. Refer to the configuration drawing (C-drawing) supplied with your system for your system's specific configuration.

### **Temperature Probes**



**NOTE!** *Each temperature probe consists of two or three pieces that plug together to make a complete probe. See SAG582127000 for part numbers and descriptions.*

Temperature probes can be connected to IB2 board and/or EIB board mounted inside the distribution cabinet. See Figure 4.5 and Figure 4.7.

The IB2 and EIB boards each allow for the connection of two (2) temperature probes. Any combination of the temperature probes can be programmed to monitor ambient temperature and/or battery temperature. A temperature probe set to monitor battery temperature can also be used for the rectifier battery charge temperature compensation feature, or the battery charge temperature compensation feature can be programmed to use the average or highest value of all battery temperature probes. The battery charge temperature compensation feature allows the controller to automatically increase or decrease the output voltage of the system to maintain battery float current as battery temperature decreases or increases, respectively. Battery life can be extended when an optimum charge voltage to the battery with respect to temperature is maintained. A temperature probe set to monitor battery temperature can also be used for the BTRM (Battery Thermal Runaway Management) feature. The BTRM feature lowers output voltage when a high temperature condition exists to control against battery thermal runaway.

The temperature sensor end of the probe contains a tab with a 5/16" clearance hole for mounting.

A temperature probe programmed to monitor battery temperature should be mounted on the negative post of a battery cell to sense battery temperature. A temperature probe used for battery charge temperature compensation and/or BTRM (Battery Thermal

Runaway Management) should also be mounted on the negative post of a battery cell. A temperature probe programmed to monitor ambient temperature should be mounted in a convenient location, away from direct sources of heat or cold.

**Figure 4.5 IB2-1 and IB2-2 Board Connections**

**Schematic Diagram of IB2 Board**

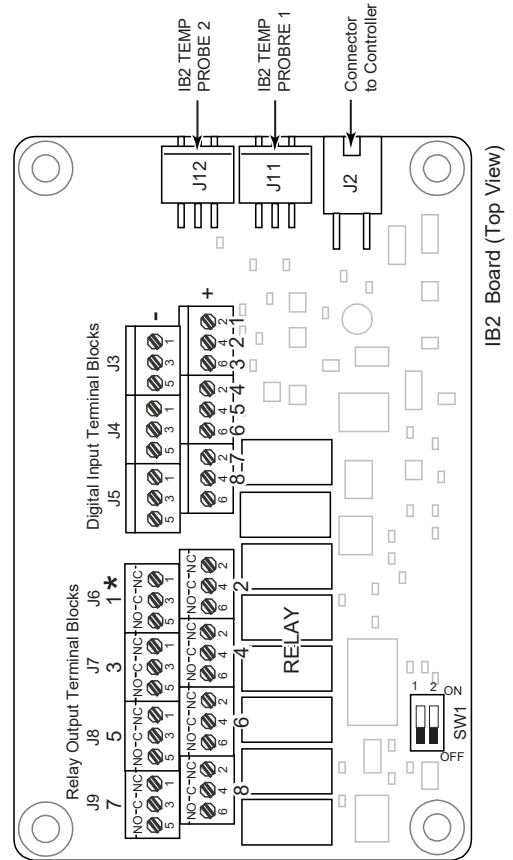
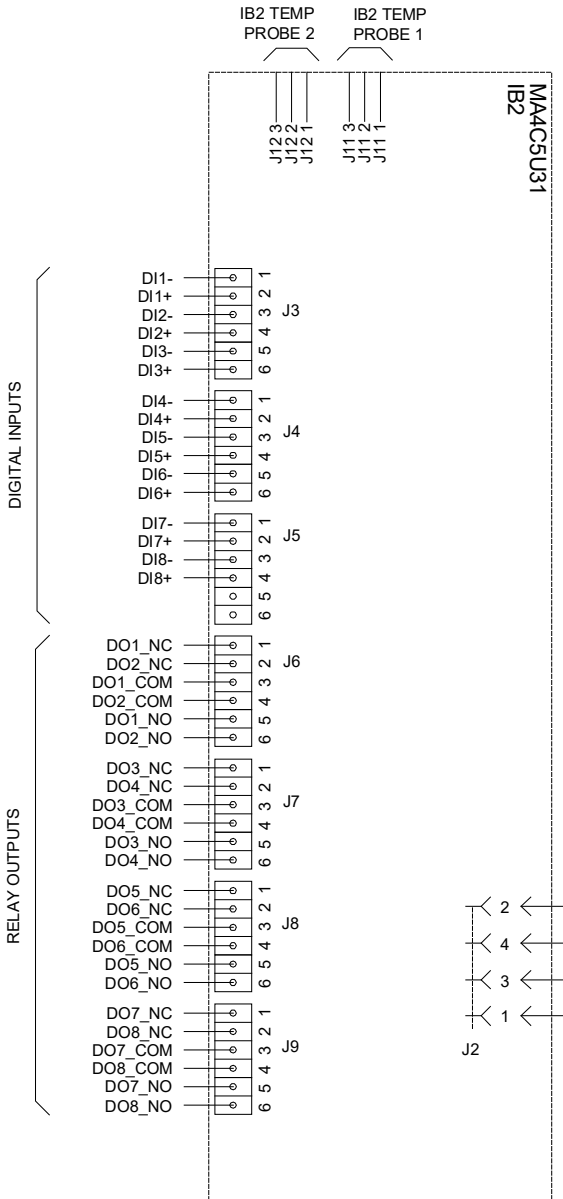

**J3-J9:**  
 Wire Size Capacity: 16-26 AWG.  
 Recommended Torque: 2.2 in-lbs.

**IB2 Board Assembly**

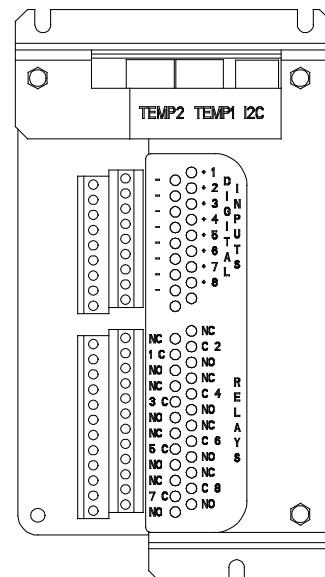

\* The relay assigned to "Critical Summary" alarm (Relay 1 on first IB2 by default) will operate in the "Fail Safe Mode". "Fail Safe Mode" means Relay 1 is de-energized during an alarm condition, opening the contacts between the C and NO terminals, and closing the contacts between the C and NC terminals.

The remaining seven (7) relays energize during an alarm condition, closing the contacts between the C and NO terminals, and opening the contacts between the C and NC terminals.

Refer to the configuration drawing (C-drawing) supplied with your system for your system's specific relay labeling.

Not all I/O points are available for customer connection (some are used for factory system connections).



**Table 4.2 Programmable Digital Inputs – IB2 Board**

Programmable Digital Input	IB2 Pin No.		Factory Wiring	Default Digital Input Function	Customer Defined Digital Input Function		
1	J3-2	+	The digital inputs may be preprogrammed for specific functions and have factory wiring connected. Refer to the configuration drawing (C-drawing) supplied with your system for your system's specific configuration.	The digital inputs may be preprogrammed for specific functions. Refer to the configuration drawing (C-drawing) supplied with your system for your system's specific configuration.			
	J3-1	-					
2	J3-4	+					
	J3-3	-					
3	J3-6	+					
	J3-5	-					
4	J4-2	+					
	J4-1	-					
5	J4-4	+					
	J4-3	-					
6	J4-6	+					
	J4-5	-					
7	J5-2	+					
	J5-1	-					
8	J5-4	+	(to customer ESTOP switch)	ESTOP			
	J5-3	-	-48 VDC				
--	J5-5		not used	not used	not used		
--	J5-6						



**NOTE!** For the NetSure 701 system, -48V is factory wired to the Digital Input #8 (-) terminal for your convenience and function predefined for ESTOP. Customer-furnished system return (0V potential) applied to terminal Digital Input #8 (+) activates the ESTOP function. See "Power System ESTOP Function" on page 24.



**NOTE!** For the NetSure 700 system, +24V is factory wired to the Digital Input #8 (+) terminal for your convenience and function predefined for ESTOP. Customer-furnished system return (0V potential) applied to terminal Digital Input #8 (-) activates the ESTOP function.

**Table 4.3 Programmable Relay Outputs – IB2 Board**

Programmable Relay Output		IB2 Pin No.	Alarms Assigned to this Relay (Default)	Alarms Assigned to this Relay (Custom)
1	NO	J6-5	The relays may be preprogrammed for specific functions. Refer to the configuration drawing (C-drawing) supplied with your system for your system's specific configuration.	
	COM	J6-3		
	NC	J6-1		
2	NO	J6-6		
	COM	J6-4		
	NC	J6-2		
3	NO	J7-5		
	COM	J7-3		
	NC	J7-1		
4	NO	J7-6		
	COM	J7-4		
	NC	J7-2		
5	NO	J8-5		
	COM	J8-3		
	NC	J8-1		
6	NO	J8-6		
	COM	J8-4		
	NC	J8-2		
7	NO	J9-5		
	COM	J9-3		
	NC	J9-1		
8	NO	J9-6		
	COM	J9-4		
	NC	J9-2		



**NOTE!** The relay assigned to “Critical Summary” alarm (relay 1 on first IB2 by default) will operate in the “Fail Safe Mode”. “Fail Safe Mode” means Relay 1 is de-energized during an alarm condition, opening the contacts between the C and NO terminals, and closing the contacts between the C and NC terminals.

The remaining 7 relays energize during an alarm condition, closing the contacts between the C and NO terminals, and opening the contacts between the C and NC terminals.

Refer to the configuration drawing (C-drawing) supplied with your system for your system’s specific relay labeling.

## 4.5 EIB (Controller Extended Interface Board) Connections (if required) (Main Bay Only)



**NOTE!** The system has one (1) EIB board installed.



**NOTE!** The alarm relay wiring previously disconnected (if applicable) will be reconnected to the IB2 card and/or EIB card provided with the retrofit.

The EIB board provides additional connection points for voltage and current inputs, programmable relay outputs, and temperature probes. The EIB board is mounted inside the distribution cabinet. Refer to Figure 4.1.

### **Current Inputs, Voltage Inputs, and Programmable Relay Outputs**

Current input, voltage input, and relay output leads are connected to screw-type terminal blocks located on EIB. Recommended torque for these connections is 2.2 in-lbs. Refer to Figure 4.7 for terminal locations. Refer to Table 4.4, Table 4.5, and Table 4.6 for pin-out information.

#### **Current Inputs**

The three shunt inputs are wired to and programmed for up to three shunts within the power system's distribution cabinet, one shunt per row of distribution. Refer to Figure 4.7 for terminal locations and Table 4.4 for pin-out information.

#### **Voltage Inputs for Battery Block and Battery Midpoint Monitoring**

The controller can monitor battery blocks (12V blocks) or midpoint battery voltage of battery strings connected to the EIB. The EIB provides a total of eight (8) DC voltage inputs for these connections. An alarm is Issued when either battery block voltage or battery midpoint voltage is abnormal. Refer to Figure 4.7 for terminal locations and Table 4.5 for pin-out information.

Refer to Figure 4.6 for connection details. Refer to the NCU Instructions (UM1M830BNA) and program the following parameters.

- **Battery Block Monitoring**

Voltage Type: For the NetSure 701 system, this can be set to "48 (Block 4)". This selects the EIB to monitor up to two (2) 48V battery strings with four (4) 12V blocks per string. For the NetSure 700 system, this can be set to "24 (Block 2)". This selects the EIB to monitor up to four (4) 24V battery strings with two (2) 12V blocks per string.

BlockVDiff(12V): This menu item appears if "48 (Block 4)" or "24 (Block 2)" is selected above. Set to the alarm threshold for battery block monitoring per site requirements. The controller issues an alarm when any block voltage of any battery string has an abnormal value. The alarm is Issued when the difference between any block voltage and a reference voltage is greater than the value of the block voltage difference setting.

Block In-Use: Set to the number of battery strings being monitored.

- **Midpoint Monitoring**

Voltage Type: Set to "Midpoint". This selects the EIB to monitor the midpoint voltage of up to eight (8) battery strings.

BlockVDiff(Mid): This menu item appears if "Midpoint" is selected above. Set to the alarm threshold for battery midpoint monitoring per site requirements. The controller issues an alarm when any battery midpoint voltage of any battery string has an abnormal value. The alarm is Issued when the difference between any battery midpoint voltage and a reference voltage is greater than the value of the block voltage difference setting.

Block In-Use: Set to the number of battery strings being monitored.

Figure 4.6 Sample Battery Block or Battery Midpoint Monitoring Connections (cont'd on next page)

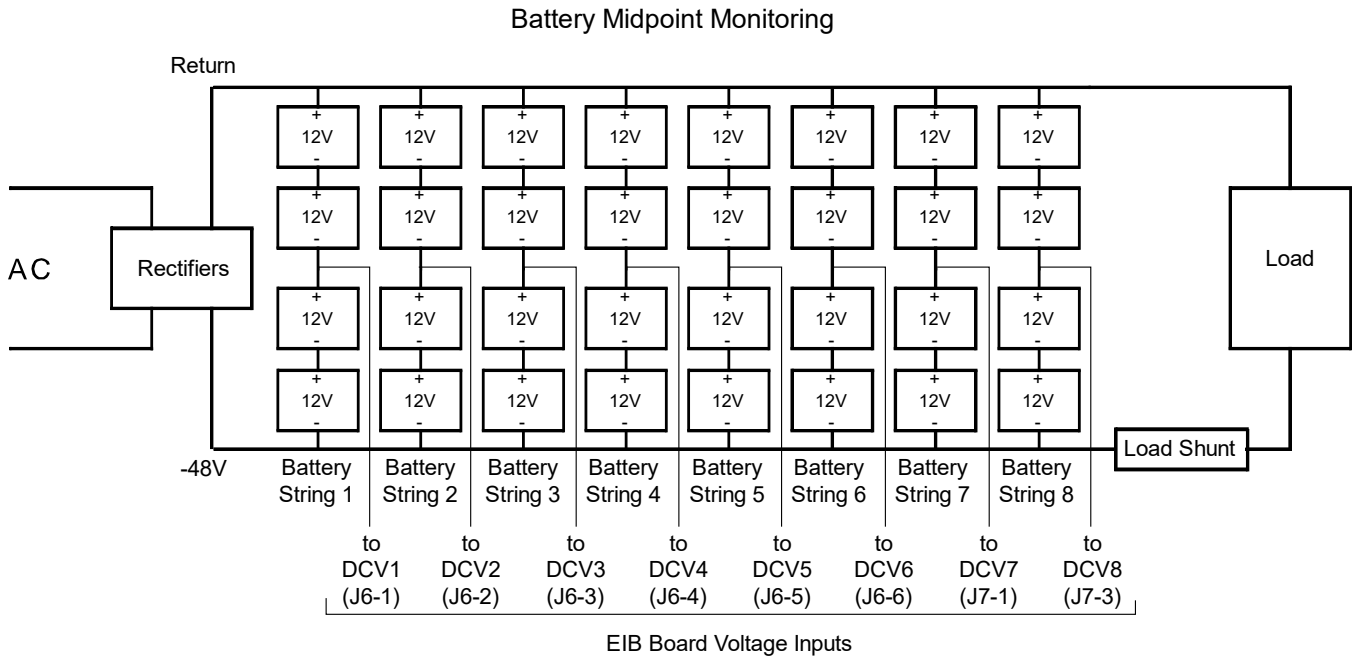
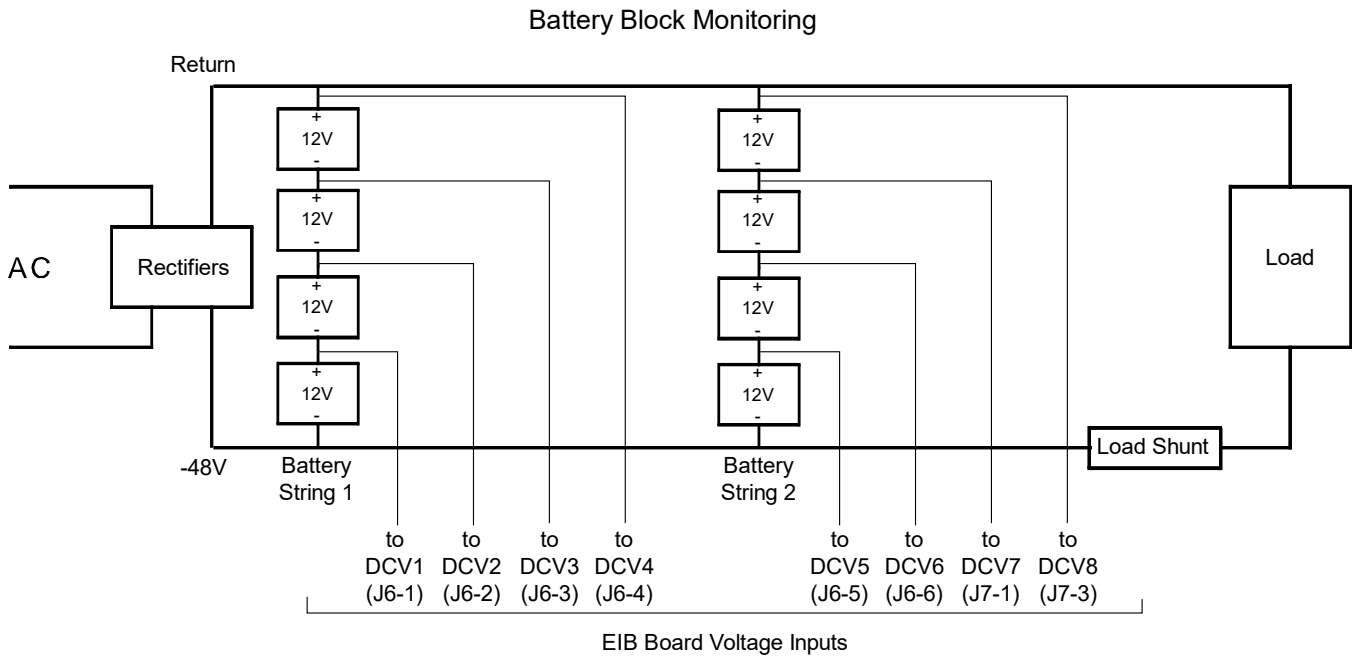
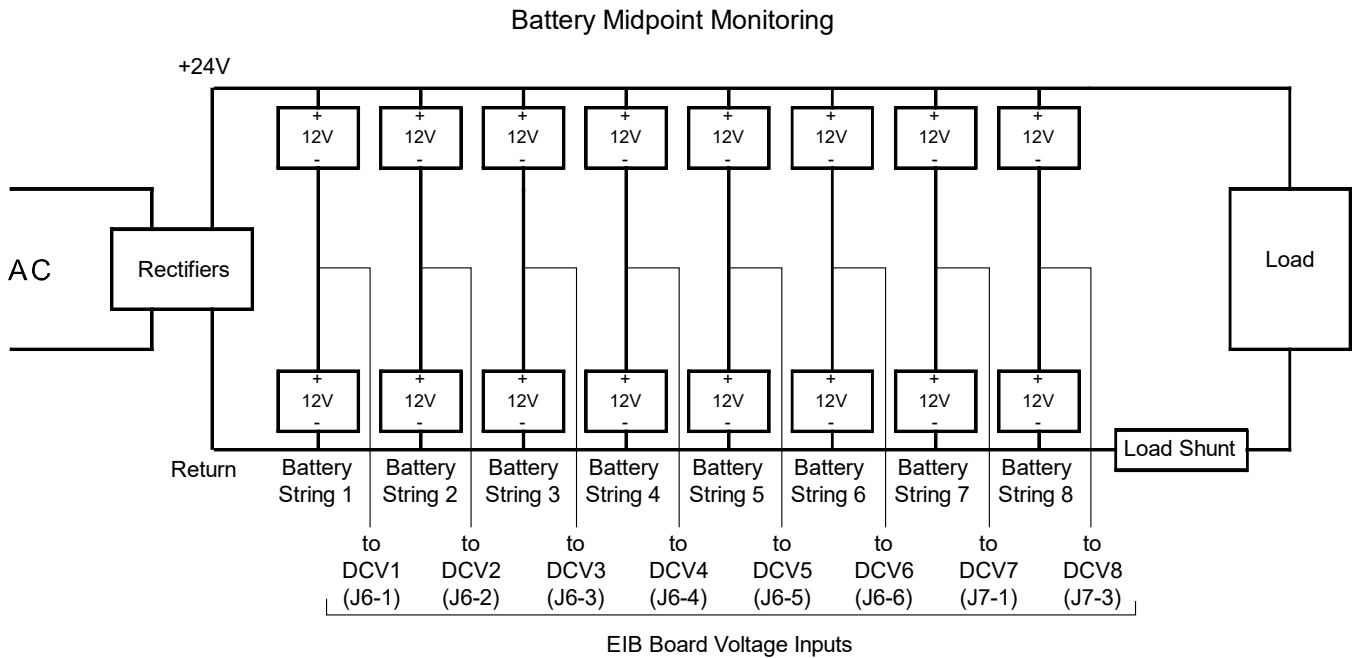

Figure 4.6 Sample Battery Block or Battery Midpoint Monitoring Connections (cont'd from previous page)



### Programmable Relay Outputs

The EIB provides five (5) programmable alarm relays with dry Form-C contacts. Connect up to five (5) relay outputs to the EIB. Refer to Figure 4.7 for terminal locations and Table 4.5 for pin-out information.

Refer to the NCU Instructions (UM1M830BNA) for programming information.

Relay Ratings: Refer to the following:

- a) Steady State : 0.5A @ 60V DC; 1.0A @ 30V DC.
- b) Peak : 3A @ 30V DC.

The relays may be preprogrammed for specific functions. Refer to the configuration drawing (C-drawing) supplied with your system for your system's specific configuration.

### Temperature Probes

Temperature probes can be connected to the EIB board mounted inside the distribution cabinet. Refer to "Temperature Probes" on page 25.

Figure 4.7 EIB-1 and EIB-2 Board Connections

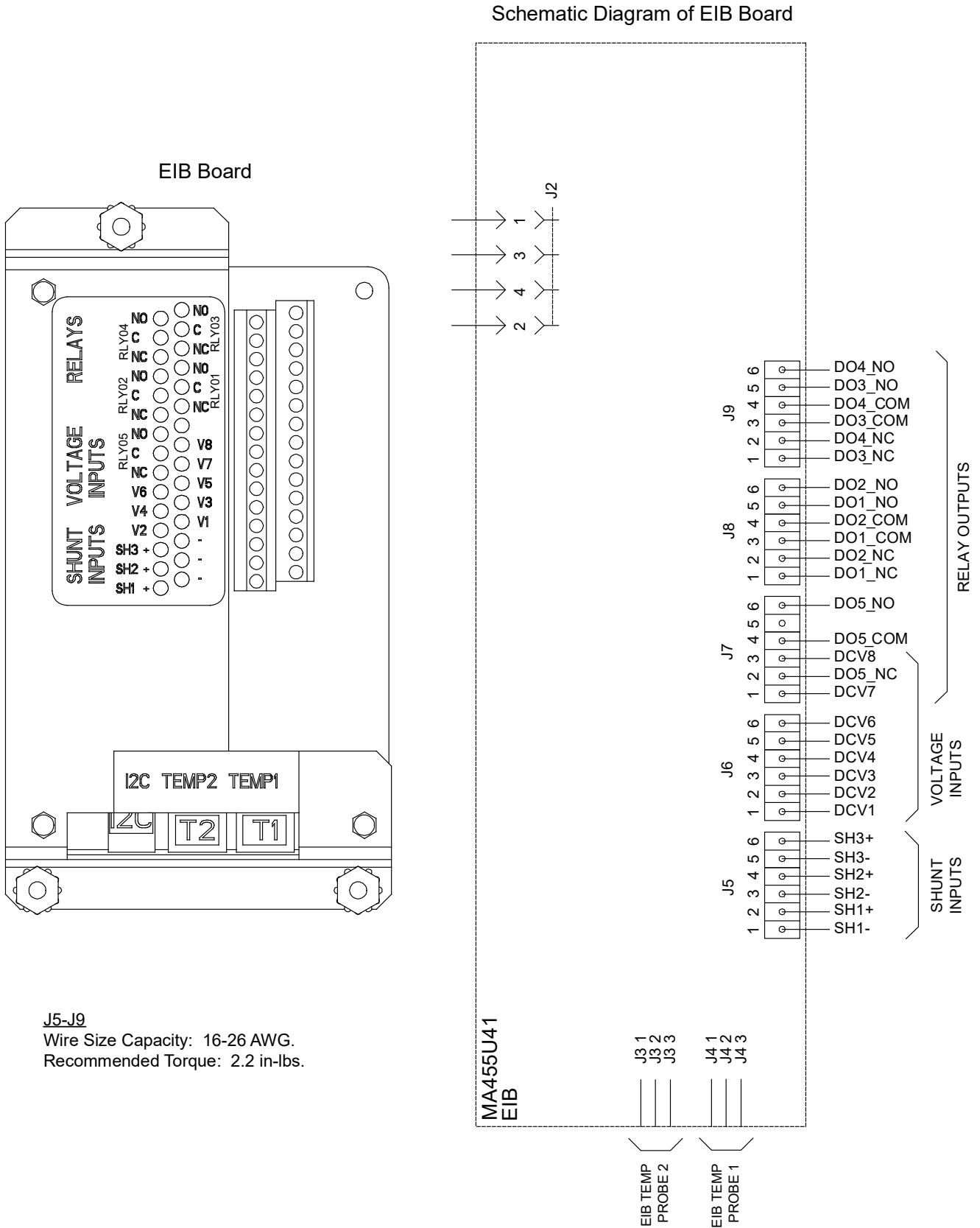

**Table 4.4 Shunt Inputs – EIB**

Shunt Input	EIB Pin No.		Factory Wiring	Default Function	Customer Defined Function
Sh1	J5-2	+	Row 2 Shunt	Row 2 Shunt - 800A, 50mV	
	J5-1	-	--		
Sh2	J5-4	+	Row 3 Shunt	Row 3 Shunt - 800A, 50mV	
	J5-3	-	--		
Sh3	J5-6	+	Row 4 Shunt	Row 4 Shunt - 800A, 50mV	
	J5-5	-	--		

**Table 4.5 Voltage Inputs – EIB**

Voltage Input	EIB Pin No.	Default Function
1	J6-1	Battery Block Monitoring
2	J6-2	
3	J6-3	
4	J6-4	
5	J6-5	
6	J6-6	
7	J7-1	
8	J7-3	

**Table 4.6 Programmable Relay Outputs – EIB**

Programmable Relay Output	EIB Pin No.	Alarms Assigned to this Relay (Default)	Alarms Assigned to this Relay (Custom)
9	NO	J8-5	The relays may be preprogrammed for specific functions. Refer to the configuration drawing (C-drawing) supplied with your system for your system's specific configuration.
	COM	J8-3	
	NC	J8-1	
10	NO	J8-6	
	COM	J8-4	
	NC	J8-2	
11	NO	J9-5	
	COM	J9-3	
	NC	J9-1	
12	NO	J9-6	
	COM	J9-4	
	NC	J9-2	
13	NO	J7-6	
	COM	J7-4	
	NC	J7-2	



**NOTE!** The relays energize during an alarm condition, closing the contacts between the C and NO terminals, and opening the contacts between the C and NC terminals.

Refer to the configuration drawing (C-drawing) supplied with your system for your system's specific relay labeling.

## 4.6 Optional SM-DU+ and Shunt Interface Board

The optional SM-DU+ and Shunt Interface Board provides connections for up to twenty-five (25) shunt inputs. The inputs should be wired to shunts provided with distribution devices located in the distribution cabinets. Refer to Figure 4.8.

### **Procedure**

Current Inputs: Connect up to twenty-five (25) shunt inputs to the Shunt Interface Board. Observe proper polarity. Refer to the NCU Instructions (UM1M830BNA) for programming information for the unused inputs.



**NOTE!** *The shunt needs to be installed in the hot (-48V) bus. Connect the plus side of the shunt to the positive shunt input on the SM-DU+. Connect the negative side of the shunt to the negative shunt input on the SM-DU+.*



Figure 4.8 SM-DU+ and Shunt Interface Board Connections

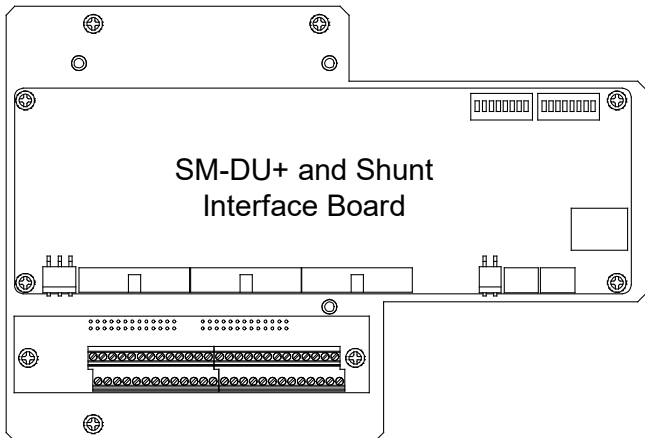
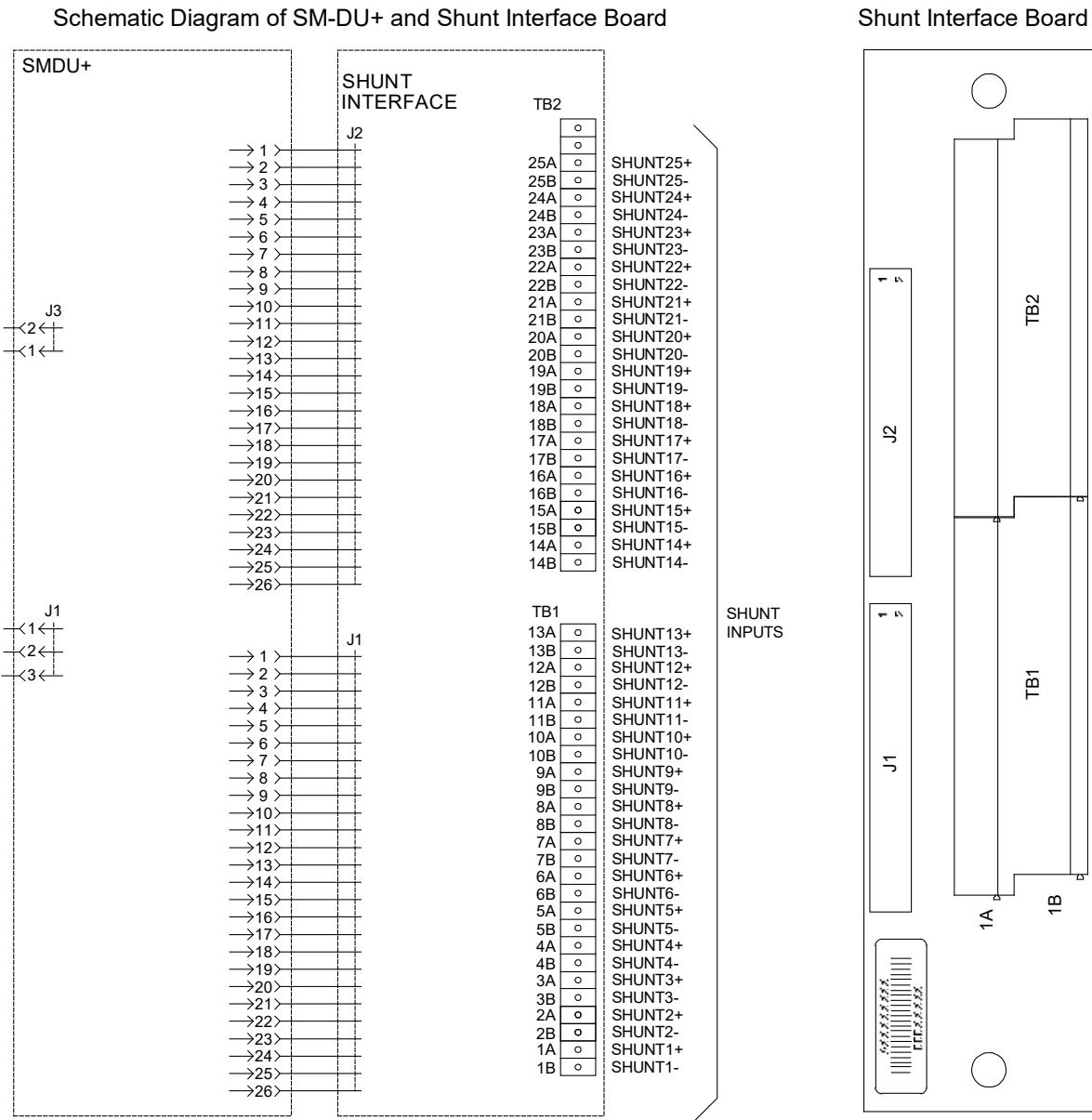

**TB1 - TB2**  
 Wire Size Capacity: 16-26 AWG.  
 Recommended Torque: 2.2 in-lbs.

## 4.7 Connecting a Device or System to the Controller's CAN Bus (if required)

A supporting device or system may be connected to the Controller's CAN Port. Refer to Figure 4.3 for location. Refer also to the external device's or system's instruction manual.

### General Procedure

1. Remove the CAN termination plug from the SM\_CAN OUT connector (or CAN1 OUT connector on the main bay for a single bay system) on the INTERFACE board of the last bay (see Figure 4.3 for location). Connect the device or system to the SM\_CAN OUT connector (or CAN1 OUT connector on the main bay for a single bay system) on the INTERFACE board of the last bay. Ensure that the last device on the controller's CAN bus has a CAN termination plug. Refer also to the external device's or system's instruction manual.

2. Reboot the Controller

**Local Menu Navigation:** At the Main Screen, press ENT and ESC at the same time to reset the NCU Controller.

**Web Menu Navigation:** Go to Advantage Settings Menu / SW Maintenance Tab / Reboot Controller button.

## 4.8 Controller Ethernet Connection (if required)

The controller provides a Web Interface via an Ethernet connection to a TCP/IP network. This interface can be accessed locally on a computer or remotely through a network. An RJ-45 10BaseT jack is provided on the IB4 Ethernet card connected to the NCU for connection into a customer's network. This jack has a standard Ethernet pin configuration scheme, twisted pair. Refer to Figure 4.9 for location and Table 4.7 for pin outs. Use shielded Ethernet cable (grounded at both ends). Refer to the NCU Instructions (UM1M830BNA) for operational details.



**NOTE!** You can access the Web pages of the power system locally by using a "crossover" or "straight" cable connected directly between your PC and the Ethernet card.



**WARNING!** The intra-building port(s) of the equipment or subassembly is suitable for connection to intra-building or unexposed wiring or cabling only. The intra-building port(s) of the equipment or subassembly MUST NOT be metallically connected to the interfaces that connect to the OSP or its wiring. These interfaces are designed for use as intra-building interfaces only (Type 2 or Type 4 ports as described in GR-1089-CORE, Revision 4) and require isolation from the exposed OSP cabling. The addition of Primary Protectors is not sufficient protection in order to connect these interfaces metallically to OSP wiring.

The intra-building port (RJ-45) of the equipment or subassembly must use shielded intra-building cabling/wiring that is grounded at both ends.

**Table 4.7 Controller RJ-45 Ethernet Port Pin Configuration**

Port Pin Number	Name	Definition
1	Tx+	Write Signal +
2	Tx-	Write Signal -
3	Rx+	Read Signal +
4	--	No connection
5	--	No connection
6	Rx-	Read Signal -
7	--	No connection
8	--	No connection

Figure 4.9 Controller Ethernet Port

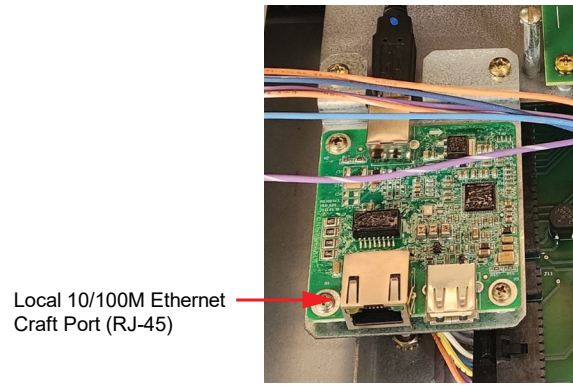

**NOTE!** This system has an IB4 board, DO NOT connect your Local Area Network (LAN) to the NCU controller's front Ethernet port.

Figure 4.10 IB4 Board Location

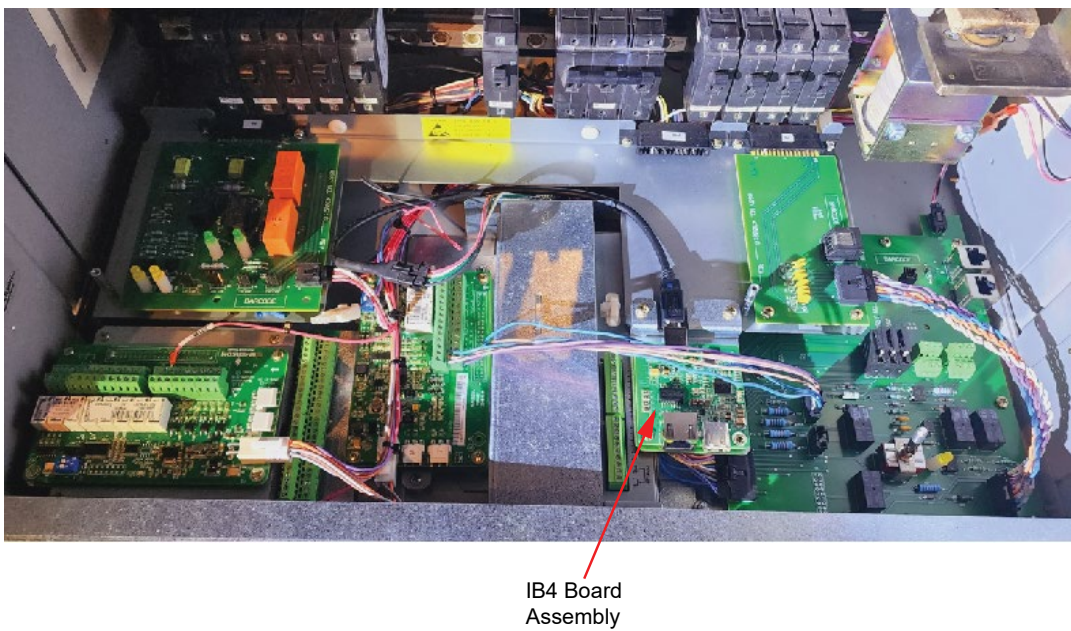

This page intentionally left blank.

## Connect with Vertiv on Social Media



<https://www.facebook.com/vertiv/>



<https://www.instagram.com/vertiv/>



<https://www.linkedin.com/company/vertiv/>



<https://www.twitter.com/vertiv/>



---

Vertiv.com | Vertiv Headquarters, 505 N Cleveland Ave, Westerville, OH 43082, USA

© 2024 Vertiv Group Corp. All rights reserved. Vertiv™ and the Vertiv logo are trademarks or registered trademarks of Vertiv Group Corp. All other names and logos referred to are trade names, trademarks or registered trademarks of their respective owners. While every precaution has been taken to ensure accuracy and completeness here, Vertiv Group Corp. assumes no responsibility, and disclaims all liability, for damages resulting from use of this information or for any errors or omissions.