

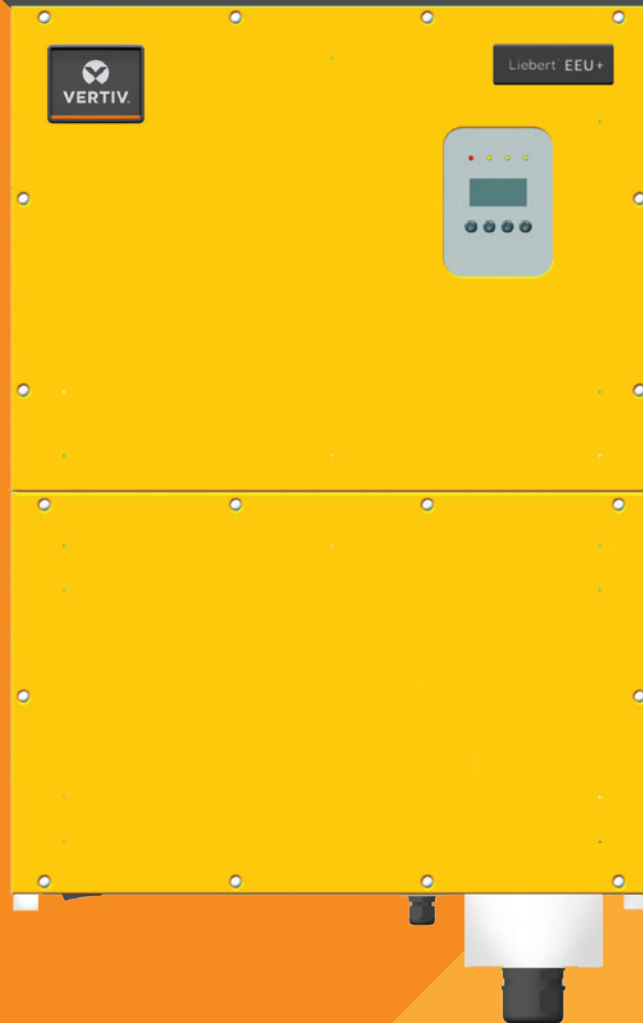

Liebert® EEU +

(Energy Export Units)
Reliable On-Grid Inverter
30kW-50kW



Liebert® EEU +

(Energy Export Units)

Reliable On-Grid Inverter - 30kW-50kW



FEATURES

- MPPT efficiency > 99.9%
- Maximum efficiency > 98.3%
- Three independent MPP tracking gains optimal energy harvesting
- Low sensitivity to grid disturbances to avoid undesired disconnection from the grid
- Wide range of input voltage and operation environment
- Wide DC input range from 250V up to 950V
- Wide operating temperature range -25°C to +60°C
- IP65 harshest industrial protection for indoors & outdoors
- RS232/RS485/WiFi Interfaces
- Easy-to-read LCD display with all operational status and monitored data



APPLICATIONS

- Residential Grid Export
- Commercial Grid Export
- Decentralised Power Plants

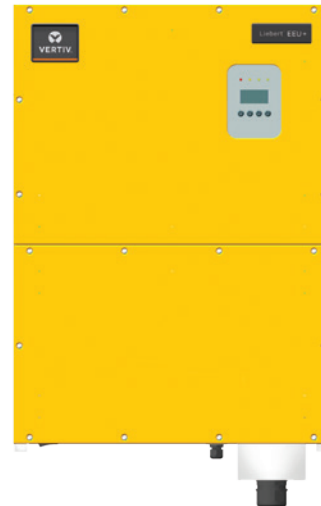

Efficiency curve

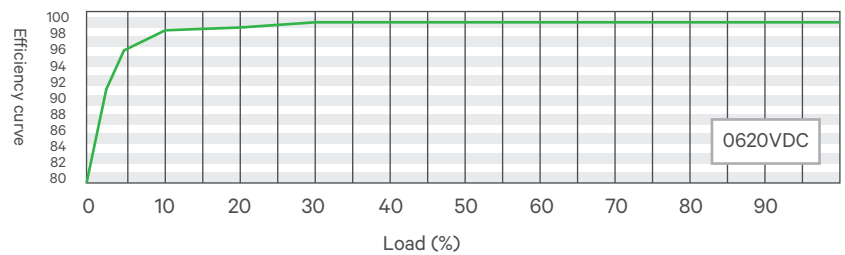

Circuit diagram

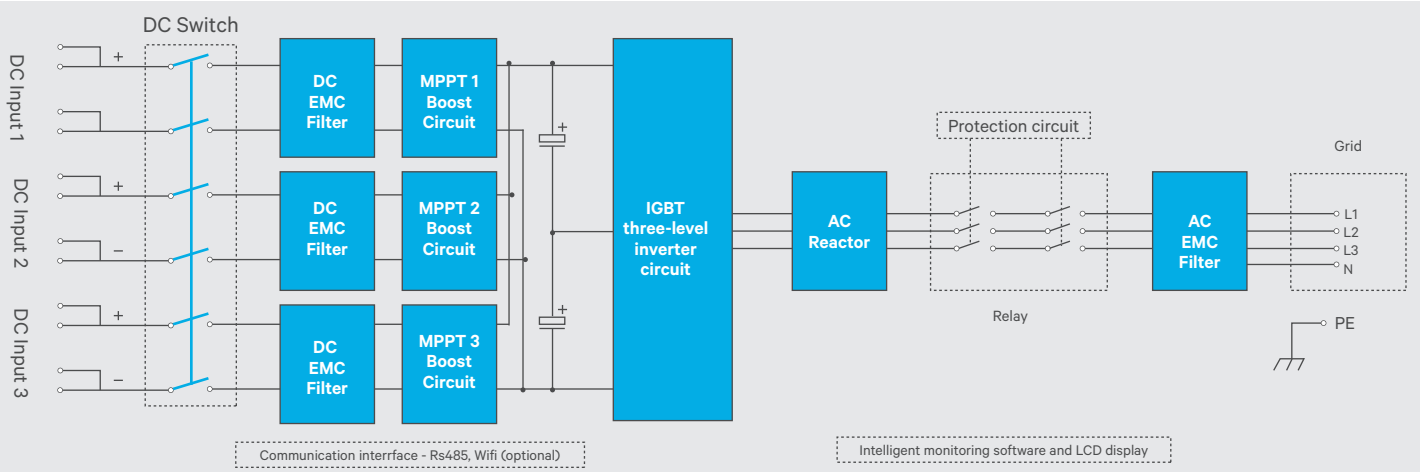

SPECIFICATIONS

| Model | EEU+ 30KW | EEU+ 50KW |
|--|------------------|-------------|
| Input(DC) | | |
| Max. DC power | 35KW | 67 KW |
| Max. DC voltage | 1000V | |
| MPPT voltage range | 250-950V | |
| Full load mppt voltage range | 480-800V | |
| Normal DC voltage | 620V | |
| Min./start DC voltage | 200V/ 250V | |
| Number of MPP trackers | 3 | |
| Strings per MPP tracker | 2 | 4 |
| BUS.V | 620V | |
| DC Switch | yes | |
| Max. input current per MPP tracker | 26A/26A/26A | 36A/36A/36A |
| Output (AC) | | |
| Normal AC output Power | 30KW | 50KW |
| Max. AC output Power | 33KW | 55KW |
| AC voltage range | 400V +/-20% | |
| AC grid frequency range | 50/60Hz +/- 5 Hz | |
| Rated. output current | 44A | 72A |
| Max. output current | 48A | 80A |
| Phase shift (cos (p)) | +/-0.8 | |
| THDI | <3% | |
| AC connection | 3W I N I PE | |
| Topology | Transformerless | |
| Efficiency | | |
| Max. efficiency | 98.3% | 98.6% |
| Euro-eta | 98.0% | 98.2% |
| MPPT efficiency | 99.9% | |
| Consumption: standby/night | <15W/ <2W | |
| Protection devices | | |
| All-pole fault current monitoring unit | yes | |
| AC short-circuit protection | yes | |
| Ground fault monitoring | yes | |
| Mechanism Data | | |
| Dimensions (W/ L/ D) in mm | 636/ 958/ 260 | |
| Weight | 61 Kg | 68Kg |
| Environment Data | | |
| Operating temperature range | -25°C...+60°C | |
| Noise emission (typical) | <40dB | <60dB |
| Cooling concept | Natural | Fans |
| Protection rating | IP65 | |
| Features | | |
| LCD display | yes | |
| Interfaces | RS485 | |



E-mail : marketing.india@vertivco.com
Toll free : 1-800-2096070

VertivCo.com | Nitco Biz Park, 2nd Floor, Plot no. C-19, Road No.16U, Wagle Ind Estate, Thane (W), Maharashtra - 400604. India.

© 2016 Vertiv Co. All rights reserved.