

Liebert® RDC™ Remote Distribution Cabinet

User Manual



FOR HISTORICAL USE ONLY

FOR HISTORICAL USE ONLY

TABLE OF CONTENTS

IMPORTANT SAFETY INSTRUCTIONS	INSIDE FRONT COVER
SAVE THESE INSTRUCTIONS	1
1.0 INSTALLATION	2
1.1 Unpacking and Preliminary Inspection	2
1.2 Handling Considerations	2
1.3 Unit Preparation	5
1.4 Location Considerations	5
1.5 Position the Liebert RDC for Installation	6
1.6 Power Wiring	6
1.6.1 Input Power Connections	6
1.6.2 Junction Box Installation	16
1.6.3 Conduit Box Installation	19
1.7 Output Power Connections	20
1.7.1 Replacing a CT in the CT Module	21
1.8 Liebert LDMF Communication	22
1.8.1 LDMF Setup Port Connection	22
1.8.2 Liebert SiteScan® Web Monitoring Interface	23
1.8.3 Summary Alarm	23
2.0 EQUIPMENT INSPECTION AND STARTUP	24
2.1 Internal Inspection	24
2.2 Startup	24
3.0 INSPECTION AND STARTUP CHECKLIST	25
3.1 Inspection	25
3.2 Startup	26
3.3 Monitoring System Check Out	26
4.0 OPERATING INSTRUCTIONS	27
4.1 Startup Procedures	27
4.2 Normal System Shutdown	27
4.3 Normal System Turn ON	27
4.4 Current Monitoring Panel	27
4.5 Current Plus Monitoring	28
4.6 Liebert LDMF (Optional)	29
5.0 MAINTENANCE	30
5.1 Repair	30
5.2 Inspection & Cleaning	30
5.2.1 Inspection Schedule	30

FIGURES

Figure 1	Typical cabinet and floor planning dimension data	3
Figure 2	Typical tie-breaker cabinet and floor planning dimension data	4
Figure 3	Recommended minimum service and ventilation clearances	6
Figure 4	Electrical connection location for single input	7
Figure 5	Electrical connection location for two inputs	8
Figure 6	Electrical connection location for four inputs	9
Figure 7	Electrical field connections, one input with Liebert LDMF™	10
Figure 8	Electrical field connections, two inputs with Liebert LDMF™	11
Figure 9	Electrical field connections, four inputs with Liebert LDMF™	12
Figure 10	Outline drawing, neutral busbar	13
Figure 11	Outline drawing, ground busbar	13
Figure 12	Liebert LDMF™ location details with Square D® panelboards	14
Figure 13	Liebert LDMF™ location details with GE panelboards	14
Figure 14	Liebert LDMF™ Liebert SiteScan® and Liebert IntelliSlot® location and connection details	15
Figure 15	Liebert LDMF adapter board location details	15
Figure 16	Four input junction box	17
Figure 17	Junction box installation	17
Figure 18	Dual input junction box with tie breakers	18
Figure 19	Conduit box	19
Figure 20	Installation of conduit box	20
Figure 21	Electrical field connections for CT Module replacement CTs	21
Figure 22	Electrical field connections for Liebert Current Plus and LDMF™ communication and summary alarm	22
Figure 23	Liebert LDMF optional local display	29

FOR HISTORICAL USE ONLY

IMPORTANT SAFETY INSTRUCTIONS

SAVE THESE INSTRUCTIONS



NOTE

Read this entire manual before installing or operating the system.



WARNING

The shipping bands may be under tension. Use appropriate eye, face, and hand protection to safeguard against injury from band backlash.



WARNING

Verify that all incoming line voltage (power) circuits are de-energized and locked out before installing cables or making connections in the unit.

Equipment inspection and startup should be performed only by trained personnel. Lethal voltages are present during startup procedures. Electrical safety precautions must be followed throughout inspection and startup.

Only qualified service personnel should perform maintenance on the remote distribution cabinet. All voltage sources to the unit must be disconnected before inspecting or cleaning within the cabinet.

Lethal voltages exist within the equipment during operation. Observe all warnings and cautions in this manual. Failure to comply may result in serious injury or death. Obtain qualified service for this equipment as instructed.



NOTE

The unit should NOT be loosened from the shipping pallet until after all handling by forklift or pallet jack is completed.

All power wiring should be installed by licensed electricians and must comply with the NEC and applicable codes.

ELECTROMAGNETIC COMPATIBILITY—The Liebert RDC complies with the limits for a Class A digital device, pursuant to Part 15 of FCC rules.

Operation is subject to the following conditions:

- This device may not cause harmful interference.
- This device must accept any interference received, including interference that may cause undesired operation.

Operating this device in a residential area is likely to cause harmful interference that users must correct at their own expense.

The Liebert RDC complies with the requirements of EMC Directive 2004/108/EC and the published technical standards. Continued compliance requires installation in accordance with these instructions and use of accessories approved by Emerson.

1.0 INSTALLATION



NOTE

Read this entire manual before installing and operating the system. Upon receipt of a Liebert RDC Remote Distribution Cabinet, the installer should perform the following steps to ensure a top-quality installation.

1.1 Unpacking and Preliminary Inspection

A top-quality installation begins on the receiving dock.

- Inspect the shipping crate(s) for damage or signs of mishandling before unpacking the unit(s). Check Shock-Watch™ indicator.
- Open the shipping crates carefully. Use care to avoid puncturing the container with sharp objects that would damage the contents.
- Remove the packing and vapor barriers and inspect the equipment for any obvious shipping damage.



NOTE

The units should NOT be loosened from the shipping pallet until after all handling by forklift or pallet jack is completed. Complete internal inspection should be performed only after the equipment has been positioned for installation but BEFORE electrical hookup.

1.2 Handling Considerations

The Liebert RDC is bolted to a wooden pallet to allow handling by a forklift, pallet jack or similar equipment.

Check size and weight—Refer to the cabinet drawings furnished with the unit for size and weight information. Typical cabinet dimensions and weights are shown in **Figures 1 and 2**.

Plan the route—The route that the unit will follow to its installation area should be planned to ensure that all passages are large enough to accommodate the unit and that the floors are strong enough to support the weight. Check all doorways, hallways elevators, ramps and other portions of the route to determine if there are any obstructions and to ensure each is large enough and strong enough to allow easy passage.

Move with care—The Liebert RDC should be moved to the installation area on the wooden pallet using forklift or pallet jack.

If any damage as a result of shipping is observed—Immediately file a damage claim with the shipping agency and forward a copy to:

Emerson Network Power
1050 Dearborn Drive
P.O. Box 29186
Columbus, Ohio 43229 USA

Figure 1 Typical cabinet and floor planning dimension data

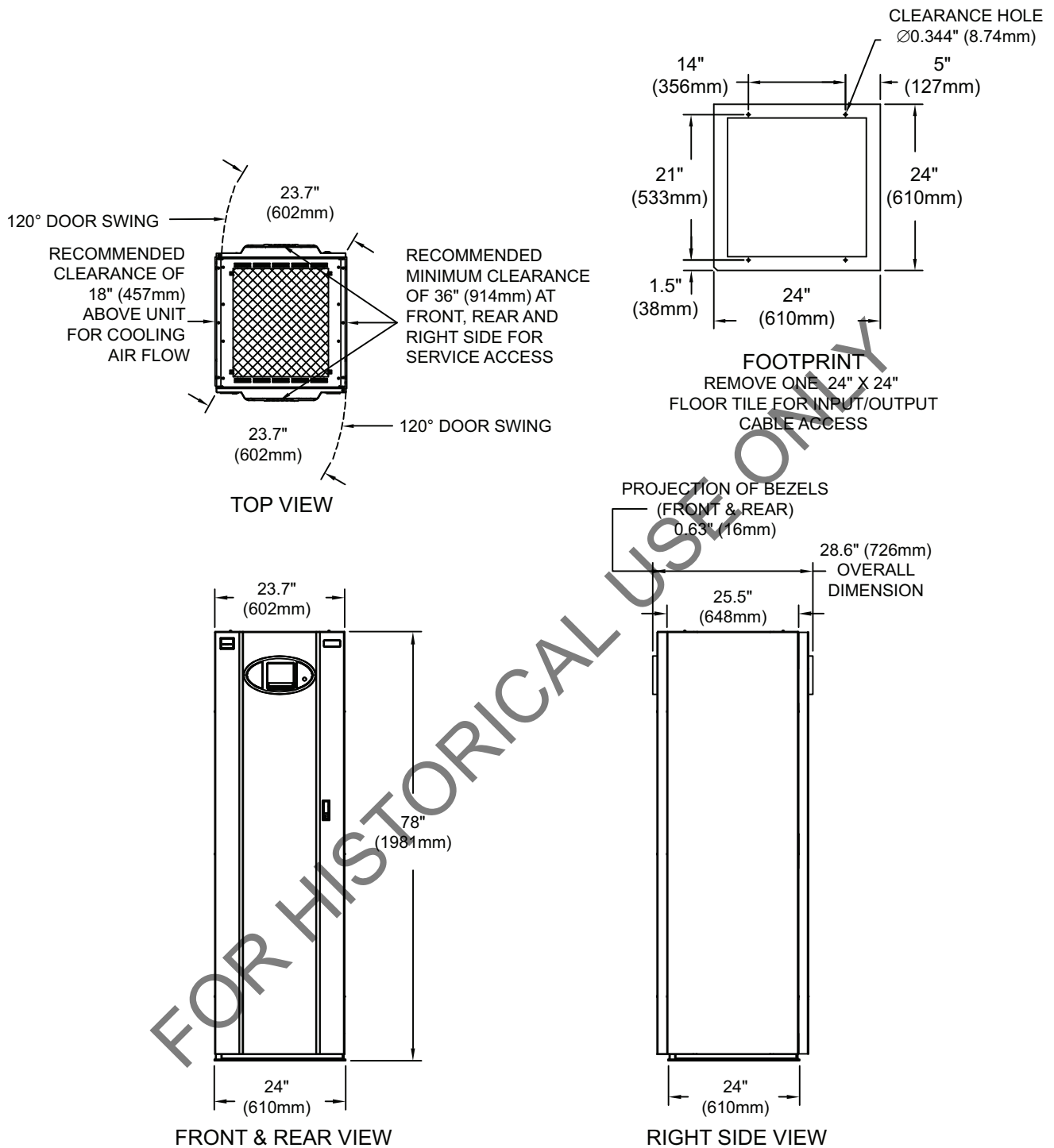

- NOTES:
1. WEIGHT: 750 LB. (340kg)
 2. HEAT OUTPUT: 3,412 BTU/HR (1kW)

RDC11014
Rev. 0

Figure 2 Typical tie-breaker cabinet and floor planning dimension data

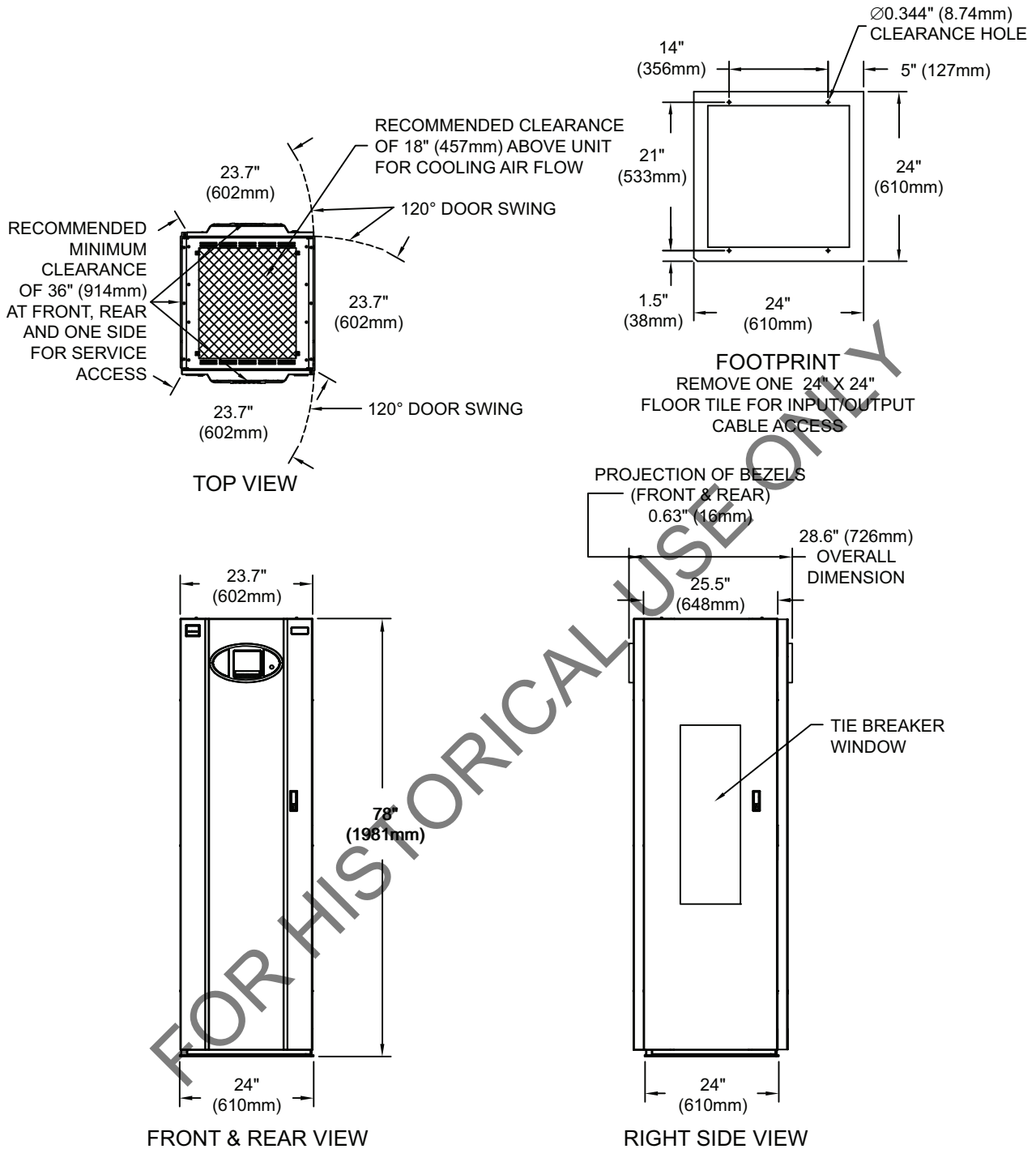

- NOTES:
1. WEIGHT: 750 LB. (340kg)
 2. HEAT OUTPUT: 3,412 BTU/HR (1kW)

RDC11016
Rev. 0

1.3 Unit Preparation

The Liebert RDC may be easily removed from the shipping pallet and installed by customer personnel. A typical procedure is as follows:

- Set the shipping pallet in a level area where there is enough room lift the Liebert RDC off the pallet onto the raised floor.
- Cut the shipping bands.



WARNING

The shipping bands may be under tension. Use appropriate eye, face and hand protection to safeguard against injury from band backlash.

- Remove front and rear doors along with the front and rear kick plate from the unit.
- Remove the bolts holding the unit to the shipping pallet. (Located in each of the four bottom corners.)
- Lift the unit from the pallet and place it on the floor.



CAUTION

Before maneuvering the unit into its final position, read and follow all advisories in **1.4 - Location Considerations**.

1.4 Location Considerations

The Liebert RDC should be located within the data center and/or close to the load(s), which it is supplying.

Equipment Location should employ the shortest output distribution cable runs consistent with logical equipment arrangement and allowances for future additions.

Operating Environment—Ambient temperatures of 32°F to 104°F (0°C to 40°C) with a relative humidity of 0% to 95% (non-condensing).

Bottom Clearance is required for exit of cables/conduits, junction box and/or for cooling airflow. This clearance is automatically provided by a raised floor with a minimum height of 15" (381mm).

Recommended Minimum Service Clearances are shown in **Figure 3**. The indicated clearances at the front, rear, and one side of the unit are required for service access by the National Electrical Code (NEC). Clearance above the unit is required for cooling airflow (exhaust).

As with all electrical devices, the Liebert RDC produces heat under normal operation. The heat output is 3412 BTU/Hr (1 kWh). This heat output should be included when calculating the environmental conditions of the room.

1.5 Position the Liebert RDC for Installation

Remove one 24" x 24" floor tile. Remove the front and rear doors and the right side panel. Remove the panelboard accent panels and the front and rear kick plates. Position the Liebert RDC over the opening; the unit will rest on top of the raised floor cross members on all four sides.

Figure 3 Recommended minimum service and ventilation clearances

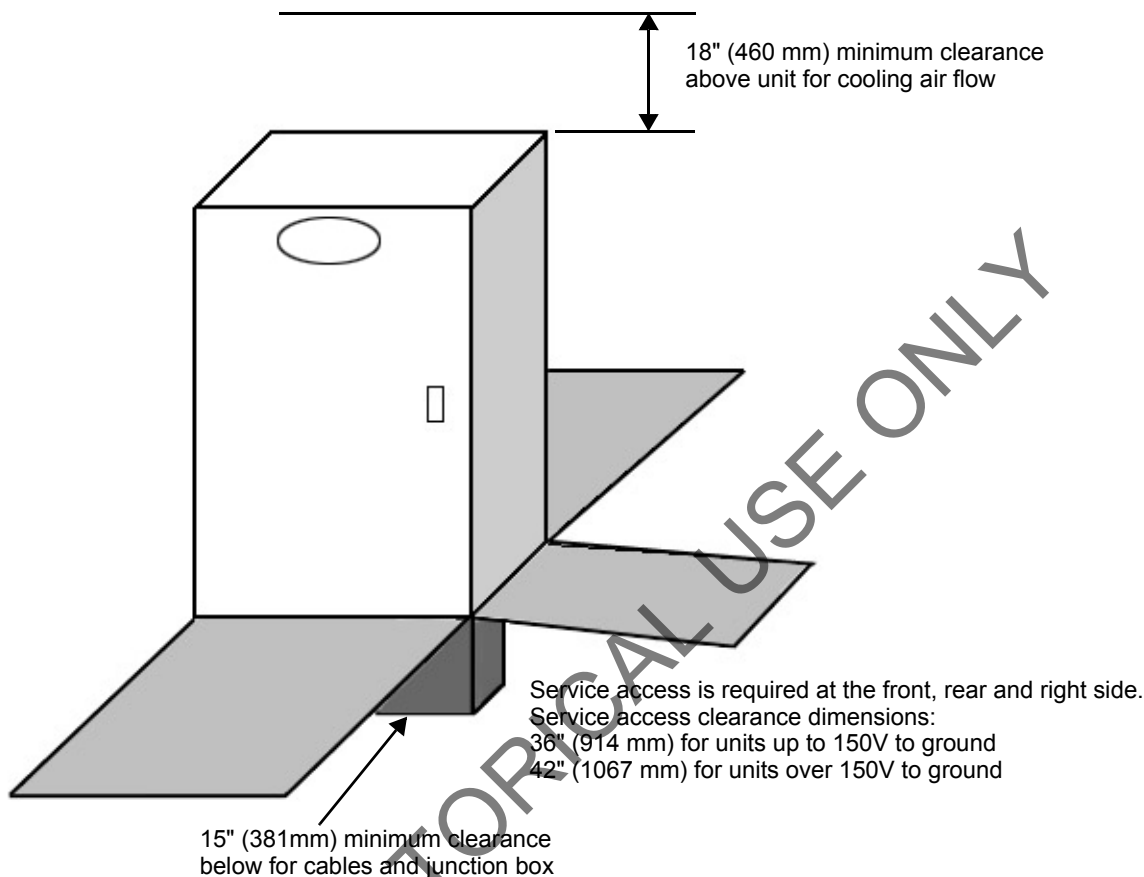

1.6 Power Wiring

Power wiring should be installed by licensed electricians. All power wiring must comply with the NEC and applicable local codes.

1.6.1 Input Power Connections

If the unit is furnished with a junction box, input power connections are made as detailed in **1.6.2 - Junction Box Installation**.

If the unit is furnished with a conduit box, input power connections are made as detailed in **1.6.3 - Conduit Box Installation**.

If a junction box is not furnished, remove front and rear doors and front and rear kick plates. Remove center conduit tray and punch to match number and size of input conduit(s). Replace conduit tray and attach input feeder.

Input power cables should be connected to the input bus bars or blocks located inside the unit. (See **Figures 4, 5 and 6** and the electrical field connection drawing supplied with the unit for details.)



WARNING

Verify that all incoming line voltage (power) circuits are de-energized and locked out before installing cables or making connections, whether in the junction box or in the unit.

To minimize disturbances caused by other loads in the building, the 3-phase power input to the unit should be supplied directly from a dedicated power source.

The input feeder circuit should be sized in accordance with the NEC and any local building codes to assure the feeder's ability to safely carry the system's full load current, including losses.

Input feeder conductors should be sized for no more than 2% voltage drop. If operation at undervoltage conditions for extended periods of time is desired, the input feeders must be oversized.

The main input feeder must consist of 3-phase conductors, one neutral and one (safety) ground conductor (4W + G).

Figure 4 Electrical connection location for single input

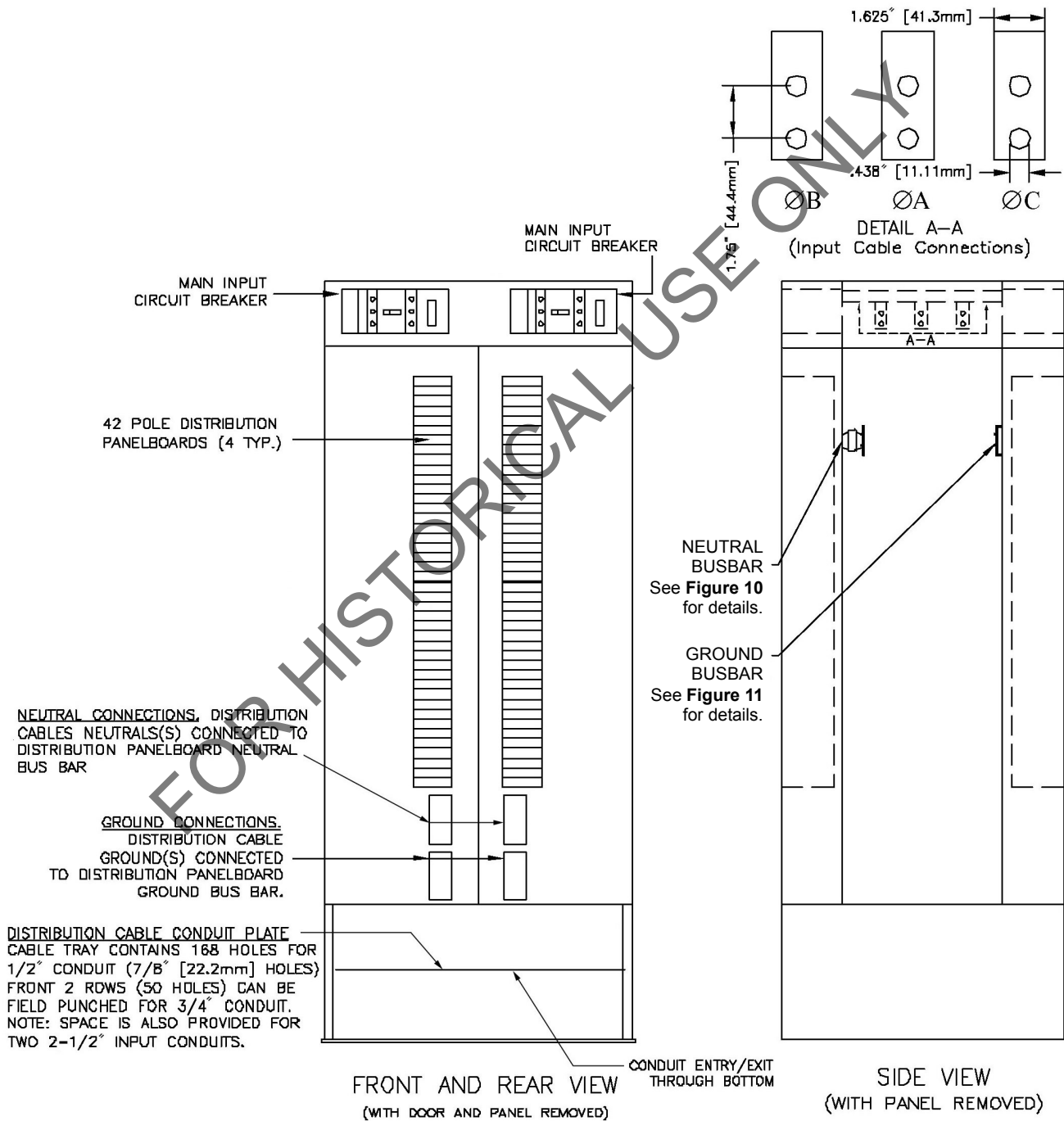

RDC15004
Rev. 3

Figure 5 Electrical connection location for two inputs

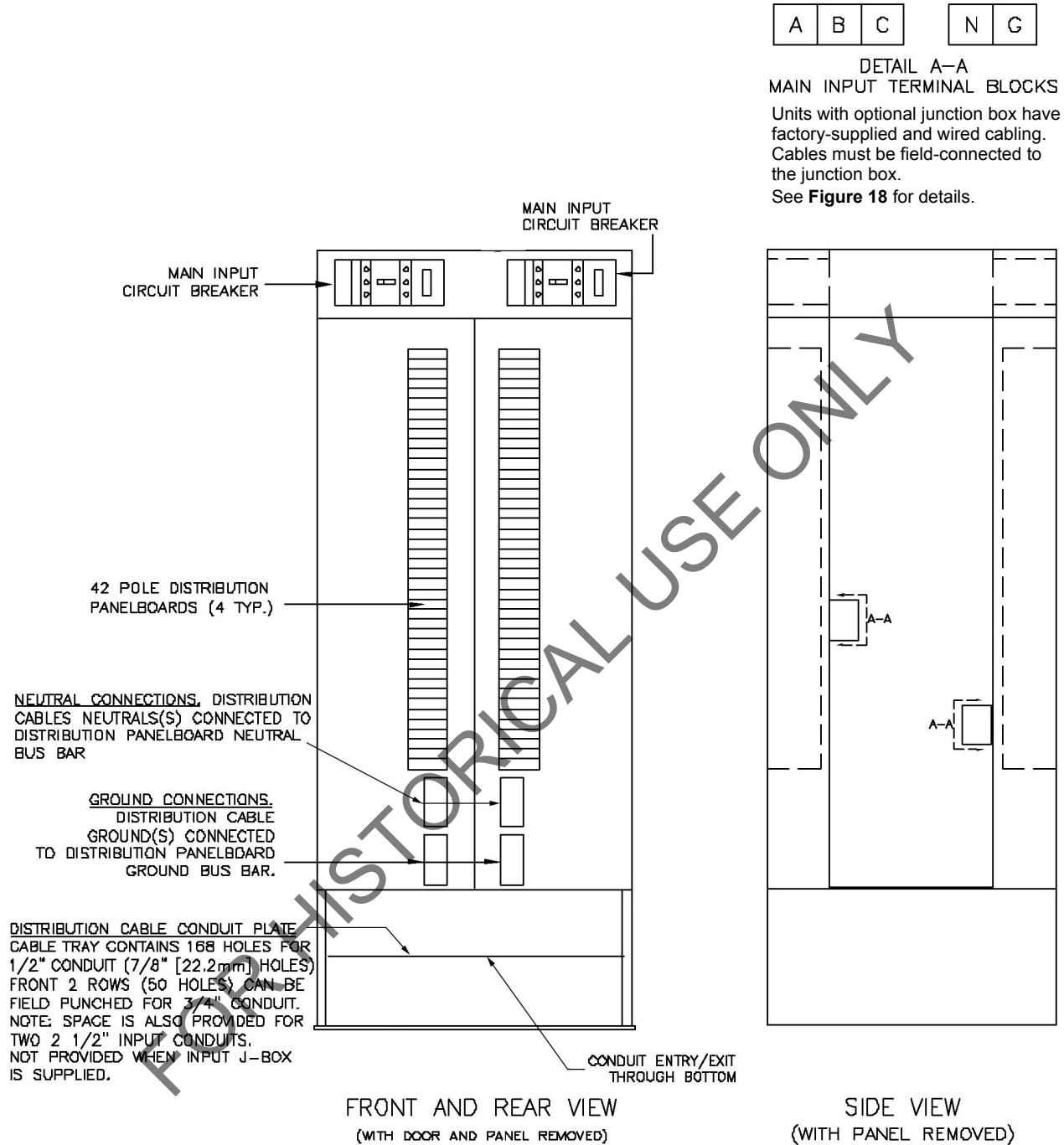

RDC15003
 Rev. 3

Figure 6 Electrical connection location for four inputs

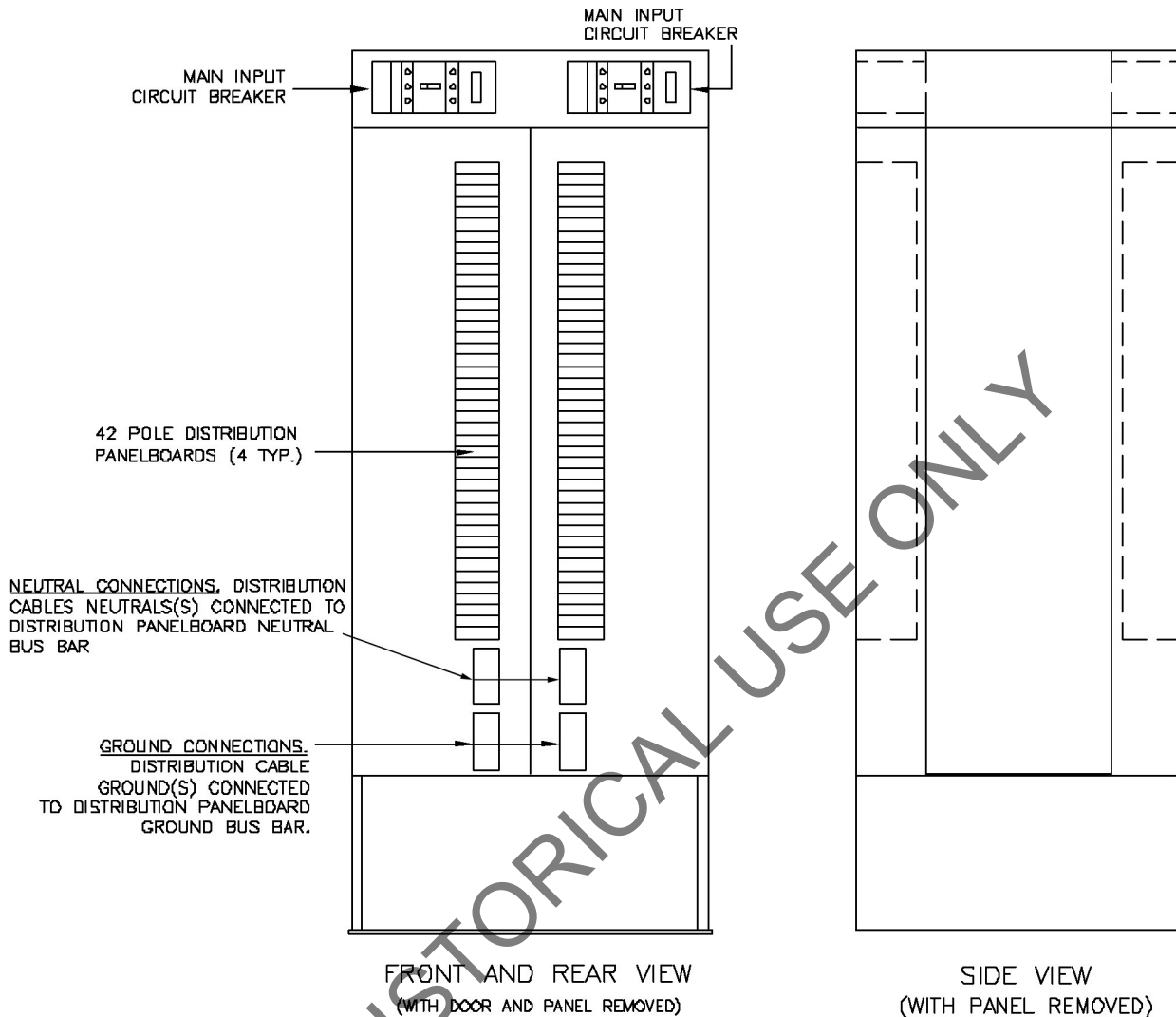

NOTE:
 Unit has factory-supplied cables wired to each main input breaker. Cables must be field-connected to the junction box (factory-supplied).
 See **Figure 16** for details.

RDC15001
 Rev. 3

Figure 7 Electrical field connections, one input with Liebert LDMF™

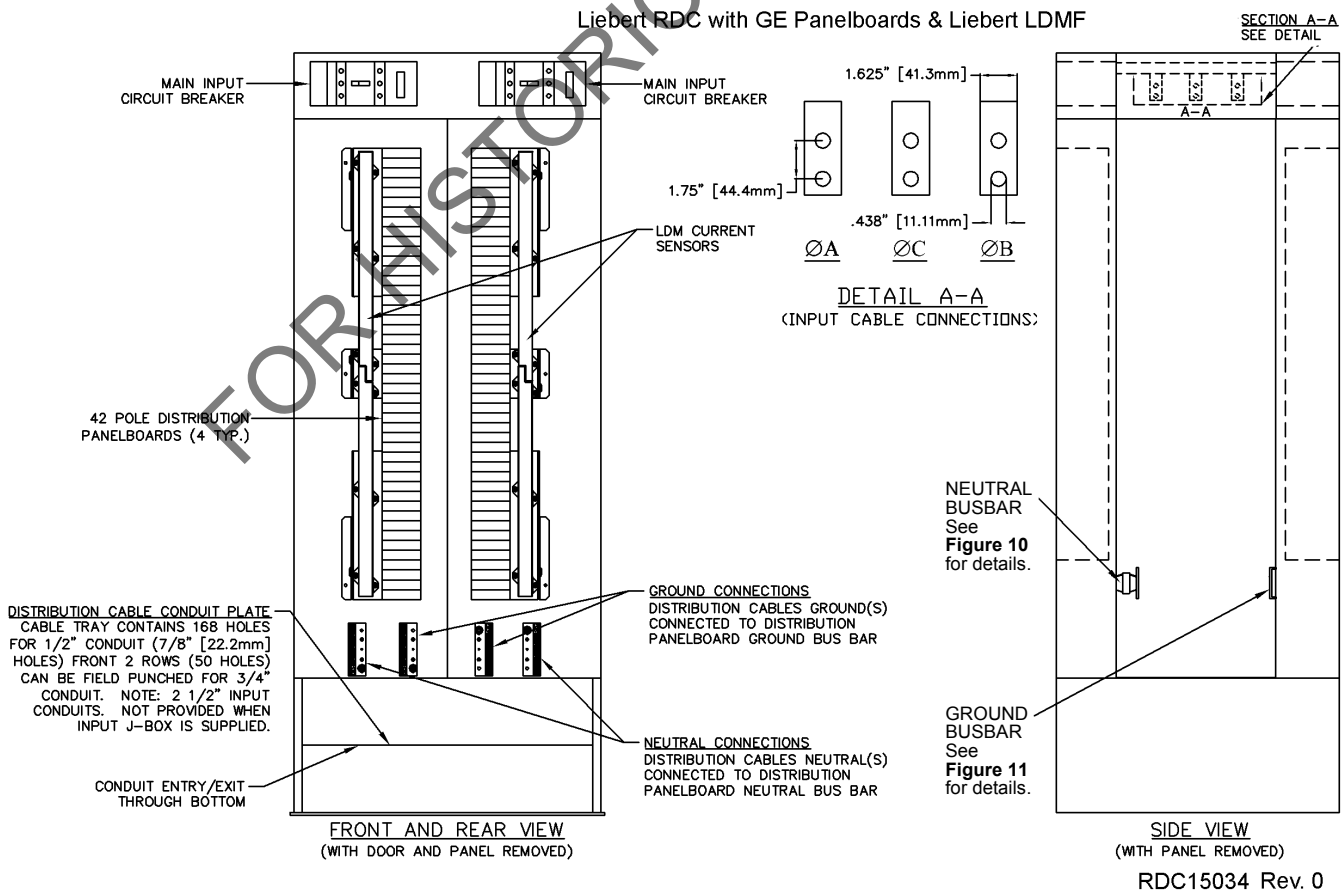
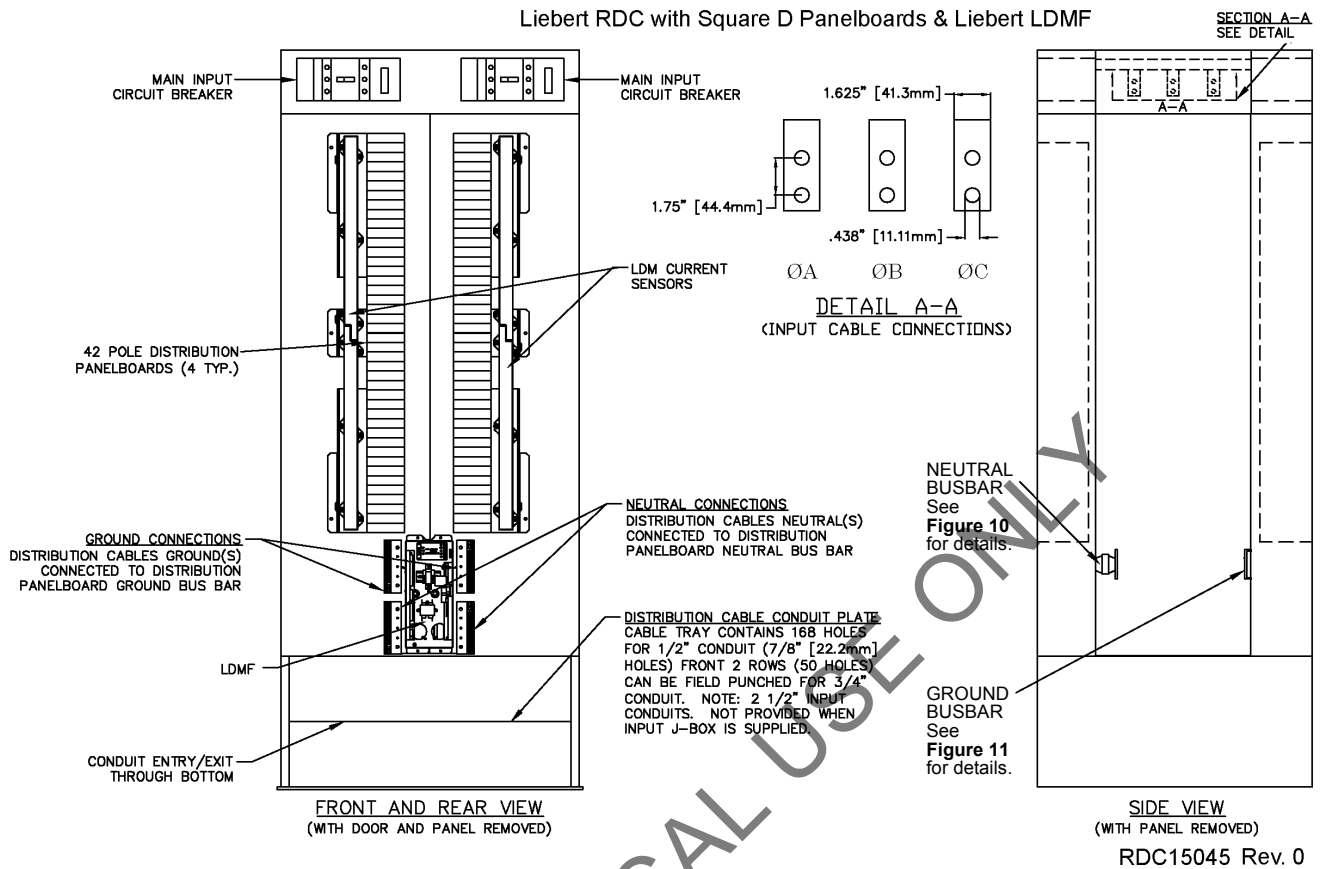

Figure 8 Electrical field connections, two inputs with Liebert LDMF™

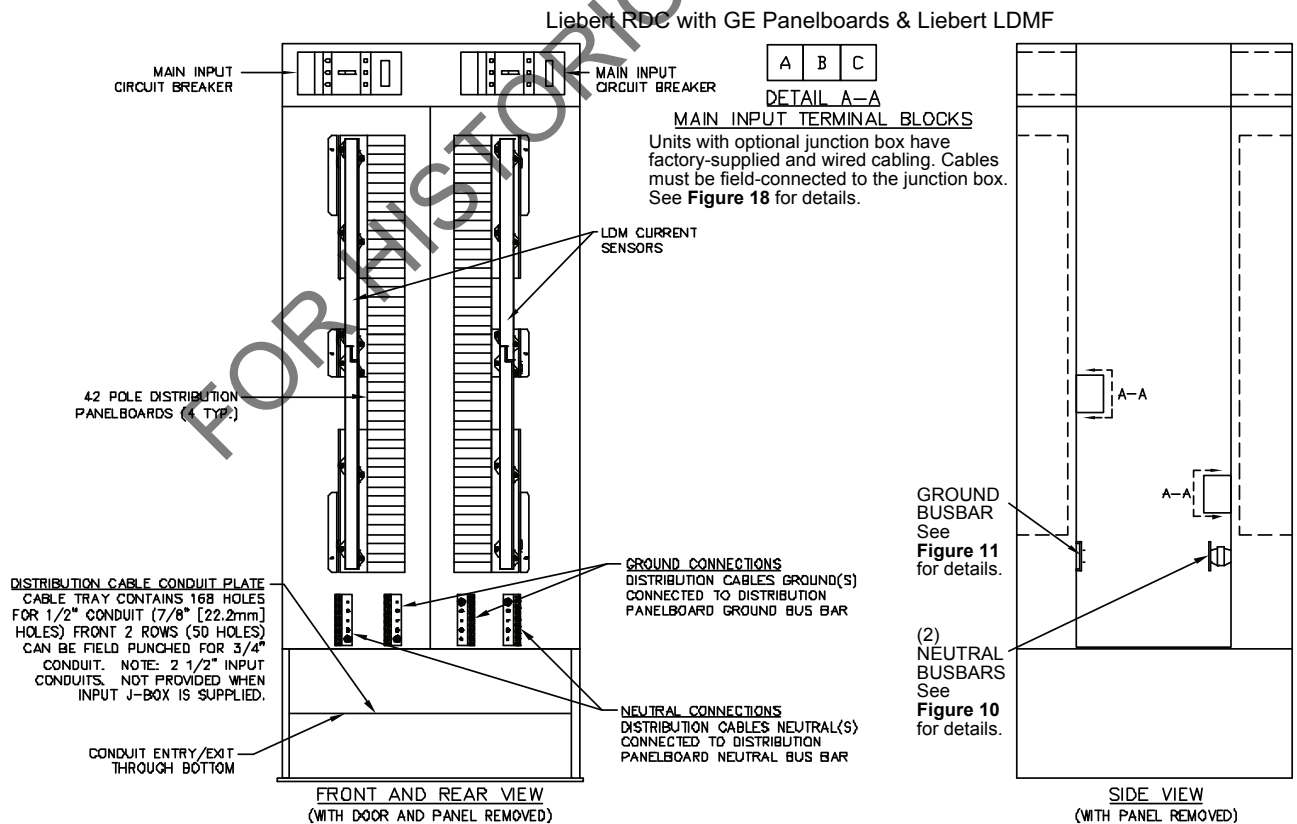
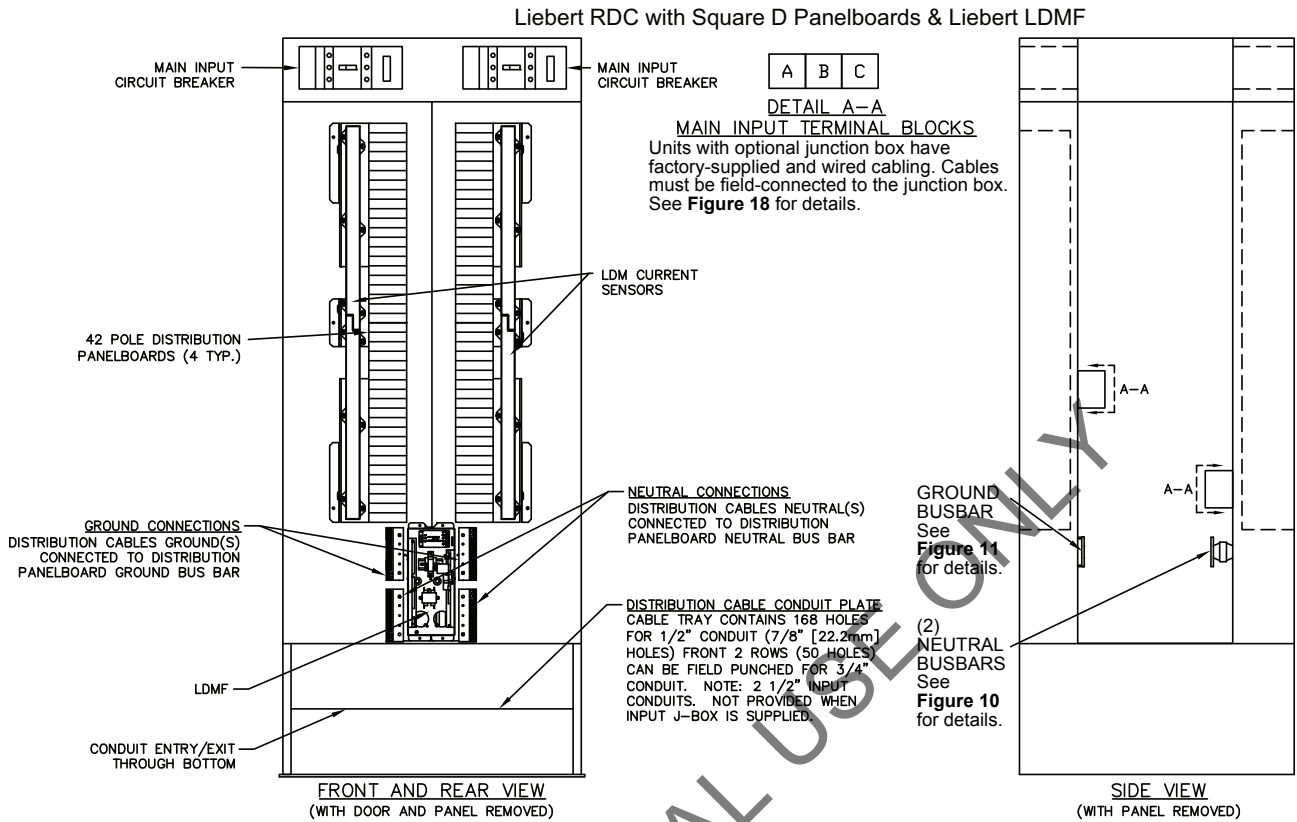
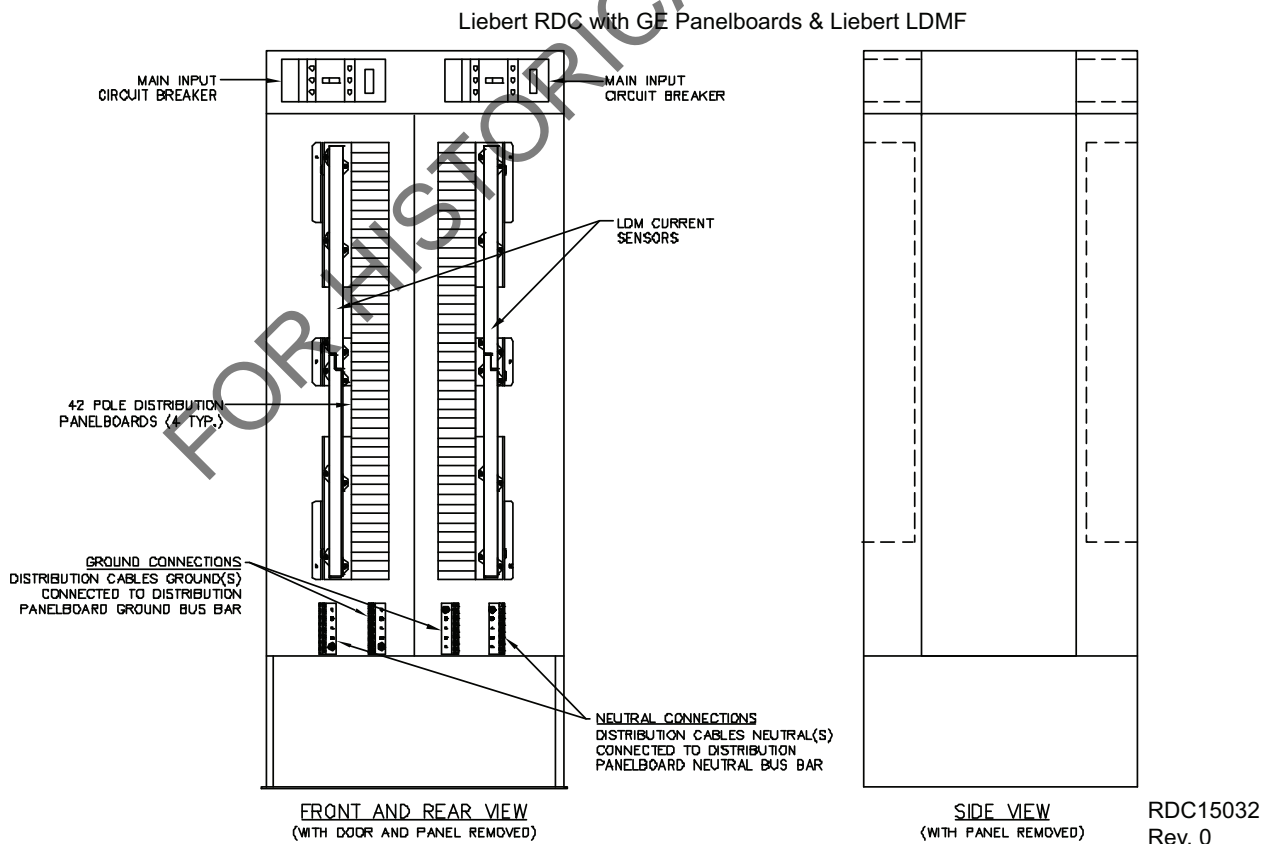
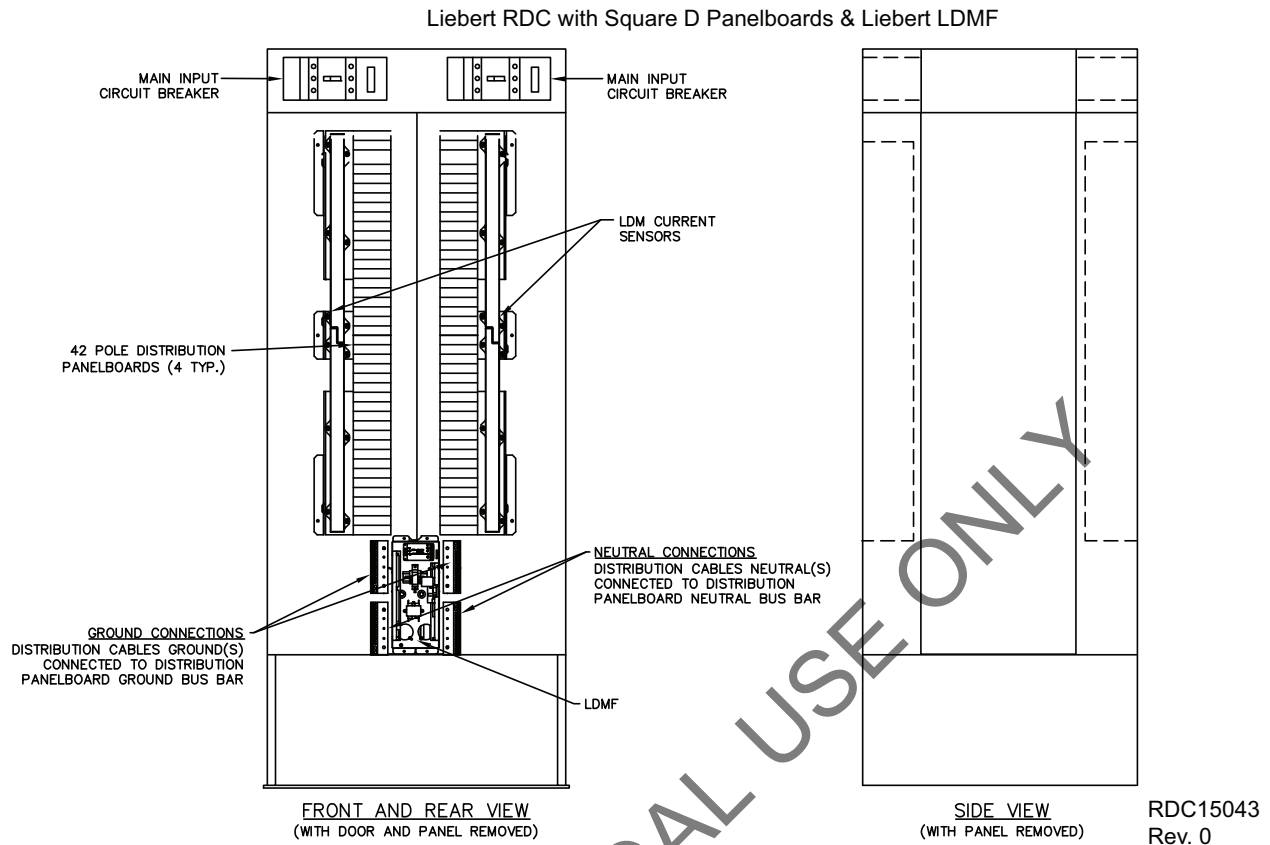

Figure 9 Electrical field connections, four inputs with Liebert LDMF™



NOTE: Unit has factory-supplied cables wired to each main input breaker. Cables must be field-connected to the junction box (factory-supplied). See **Figure 16** for details.

Figure 10 Outline drawing, neutral busbar

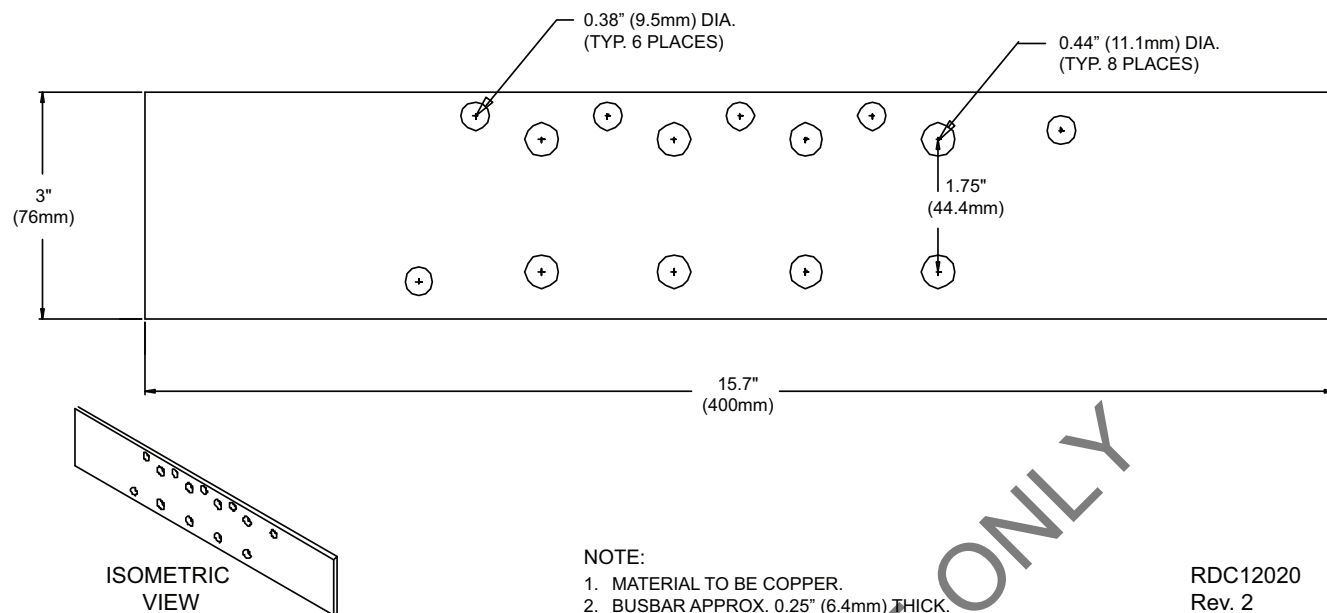

Figure 11 Outline drawing, ground busbar

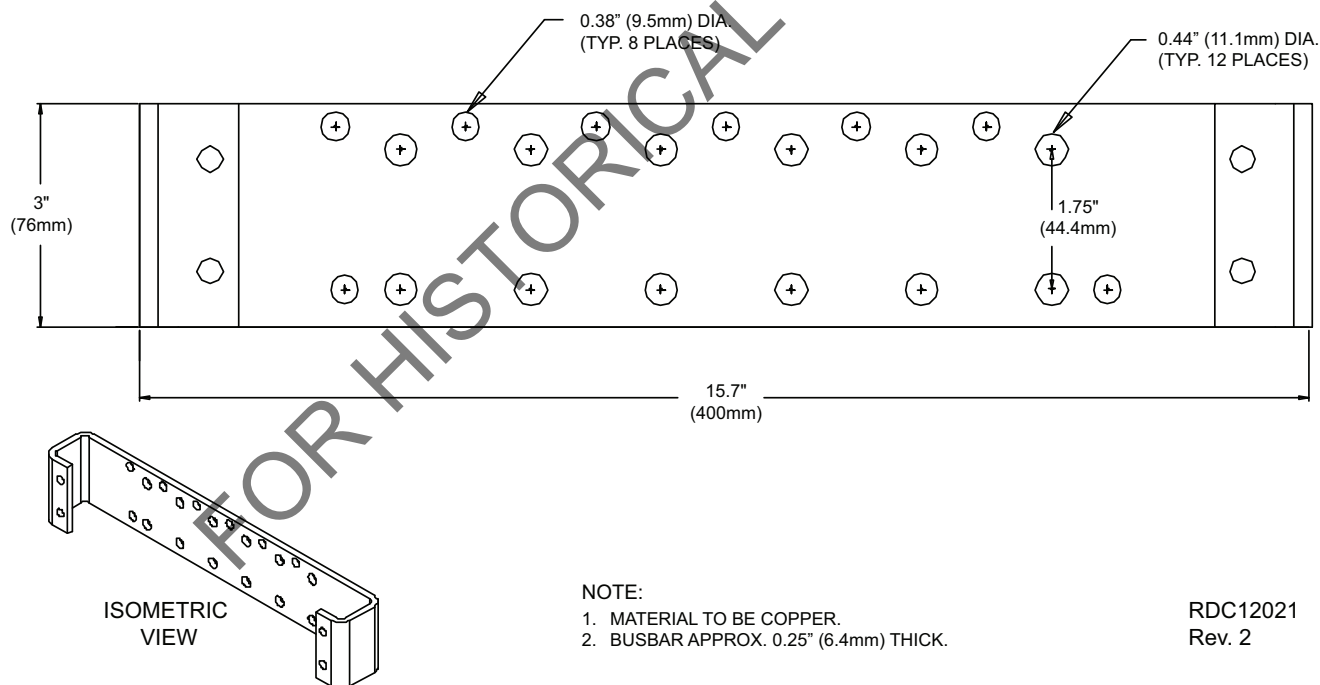

Figure 12 Liebert LDMF™ location details with Square D® panelboards

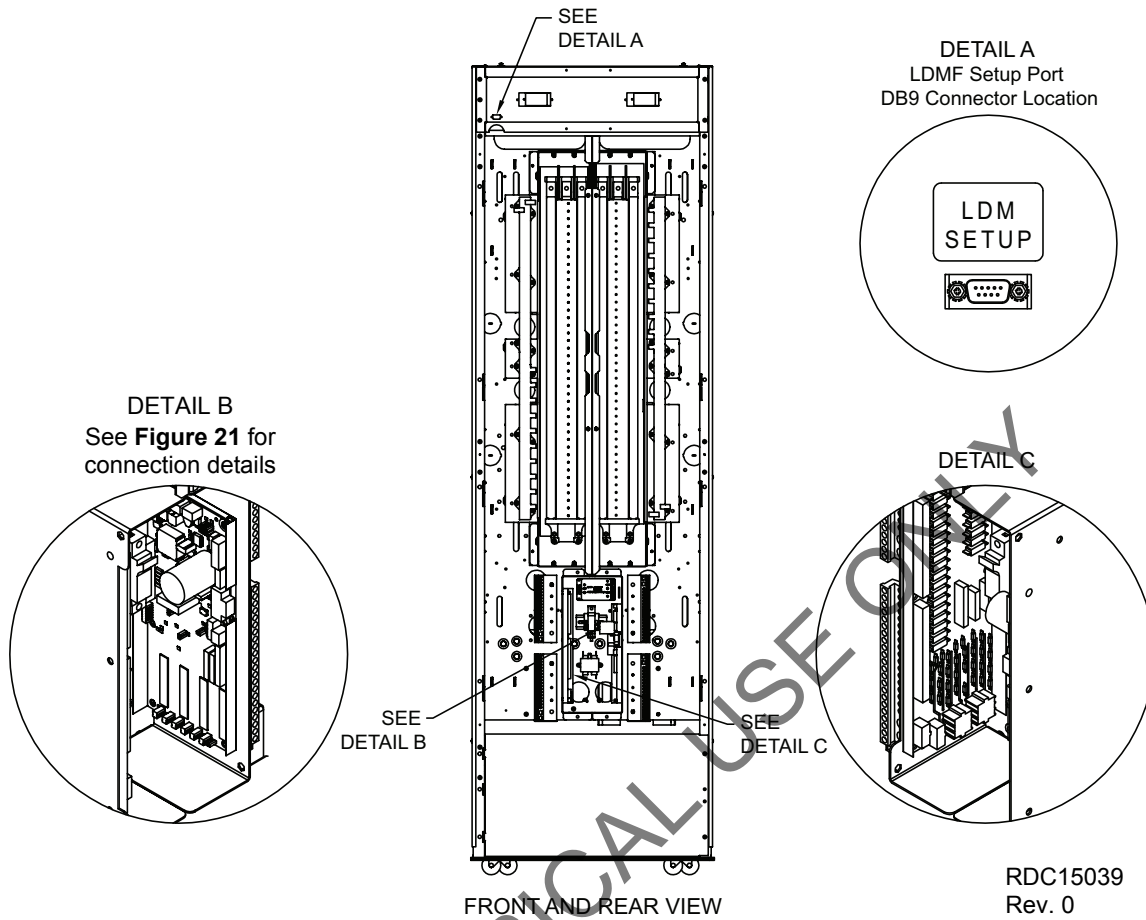

Figure 13 Liebert LDMF™ location details with GE panelboards

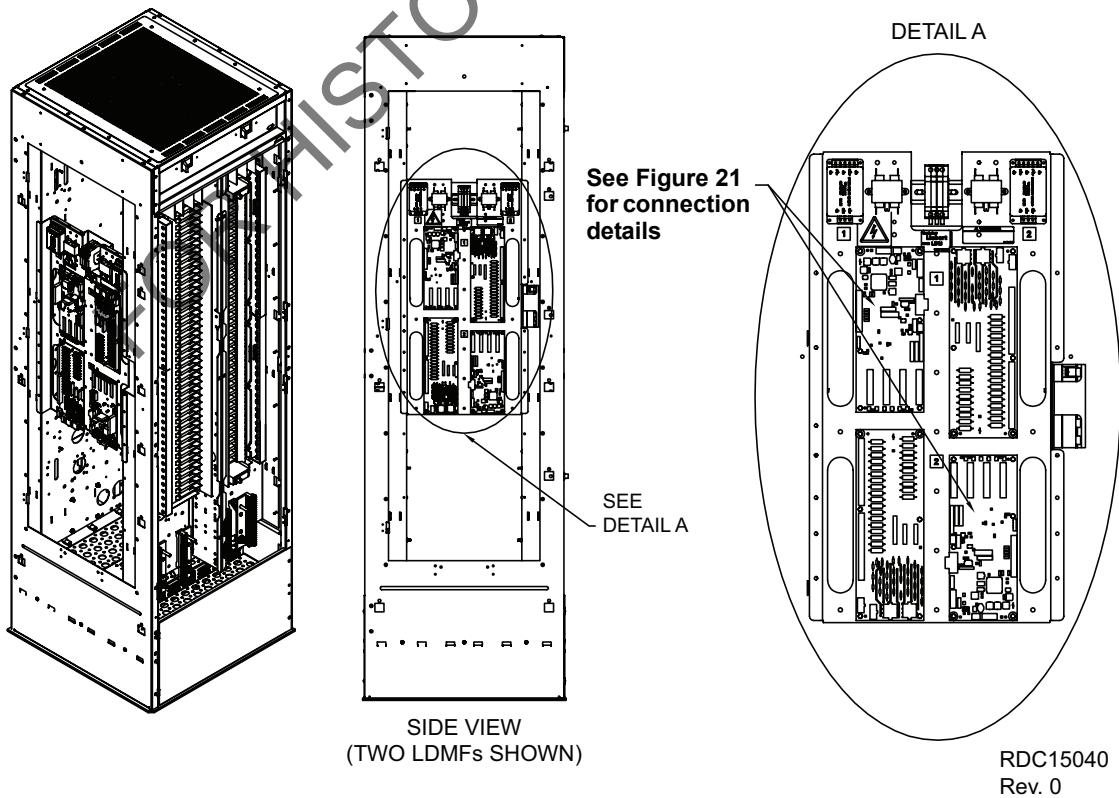

Figure 14 Liebert LDMF™ Liebert SiteScan® and Liebert IntelliSlot® location and connection details

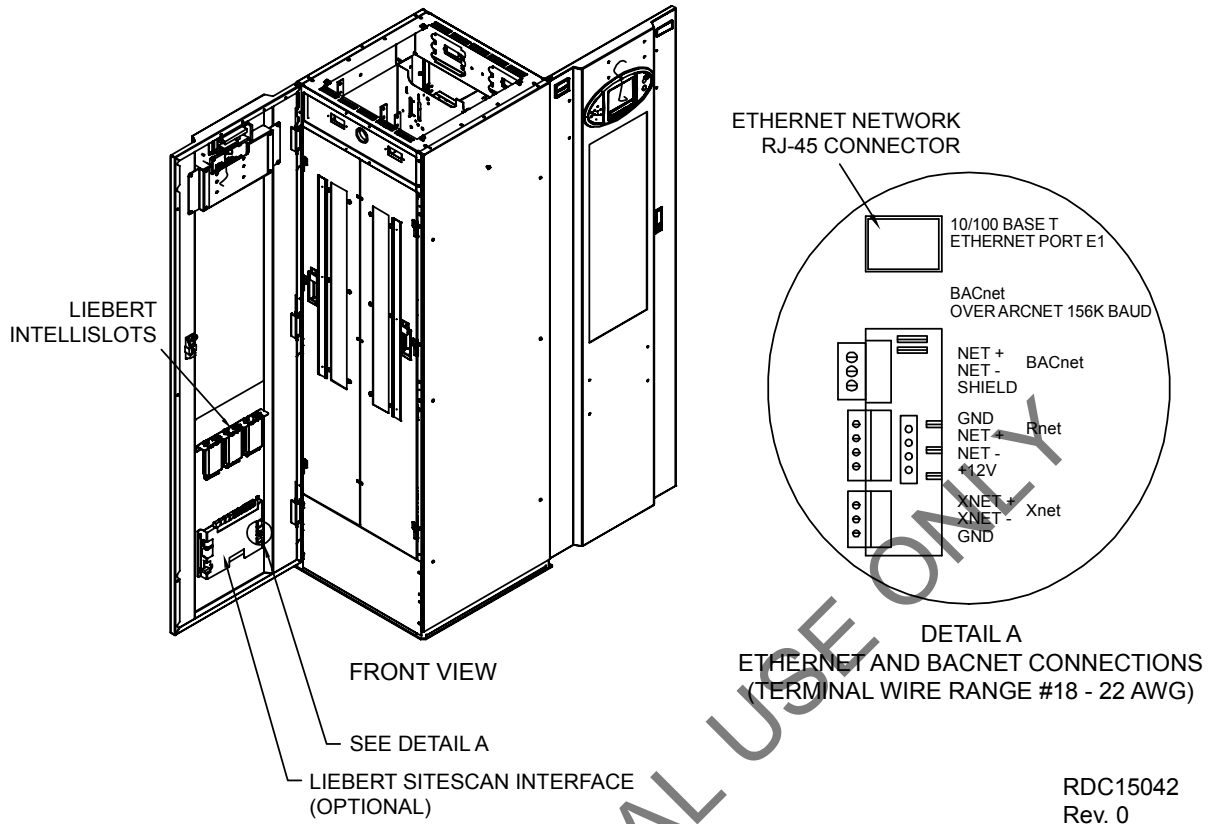
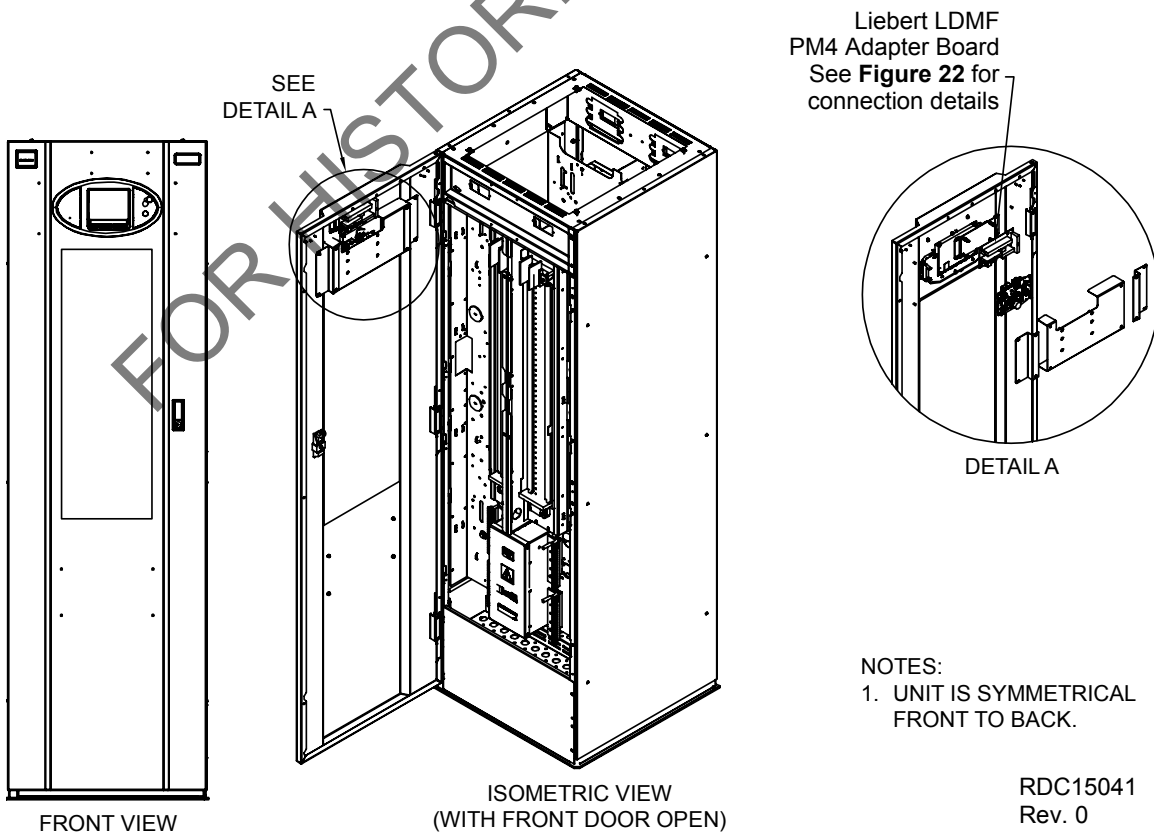

Figure 15 Liebert LDMF adapter board location details



1.6.2 Junction Box Installation

A main input power junction box is standard on the four-input Liebert RDC and available as an option on the two-input cabinet to simplify customer connections.

The junction box, if used, is shipped with the unit. Its dimensions (WxDxH) are:
20-3/4" x 45-5/16" x 14-5/16" (525 mm x 1150 mm x 363 mm).

To install the junction box:

1. Remove two 24" x 24" floor tiles and the raised floor cross member between them. Position standoffs (field supplied and installed by others) if required and secure to the floor.
2. Remove the junction box cover and carefully lower the junction box onto the standoffs.
3. Adjusting the standoffs so the top of the junction box fits up against the bottom of the raised floor cross members.
4. Reinstall the raised floor cross member. See **Figure 17**.

Junction Box Input Power Connections

Install the input feeder cables and attach to the power blocks per the junction box outline drawing supplied with the unit. See **Figure 16**. Be sure to secure the junction box prior to pulling the cables.

Reinstall the floor tile over the power blocks prior to installing the Liebert RDC. The junction box cover can be left off at this point since it will be necessary to remove the floor tile after the Liebert RDC is installed. The factory installed input cables located inside the unit must be connected to the junction box after the Liebert RDC is installed.

To make the junction box input power connections:

1. Place the Liebert RDC on the raised floor in the open area over the junction box with the front door in line with the front of the junction box.
2. Remove front and rear doors and both side panels.
3. Remove panelboard accent panels and the front and rear kick plates.
4. Unroll cables located on the shipment brace at the bottom of the unit.
5. Remove and discard the shipping braces.
6. Connect cables to power blocks in the junction box.
7. Reinstall the junction box cover and floor tile.
8. Reinstall accents, kick plates, side panels and doors.

Junction box connections must be installed in compliance with the NEC and all other applicable codes.



WARNING

Verify that incoming line voltage (power) circuits are de-energized and locked out before installing cables or making any connections in the junction box.

Figure 16 Four input junction box

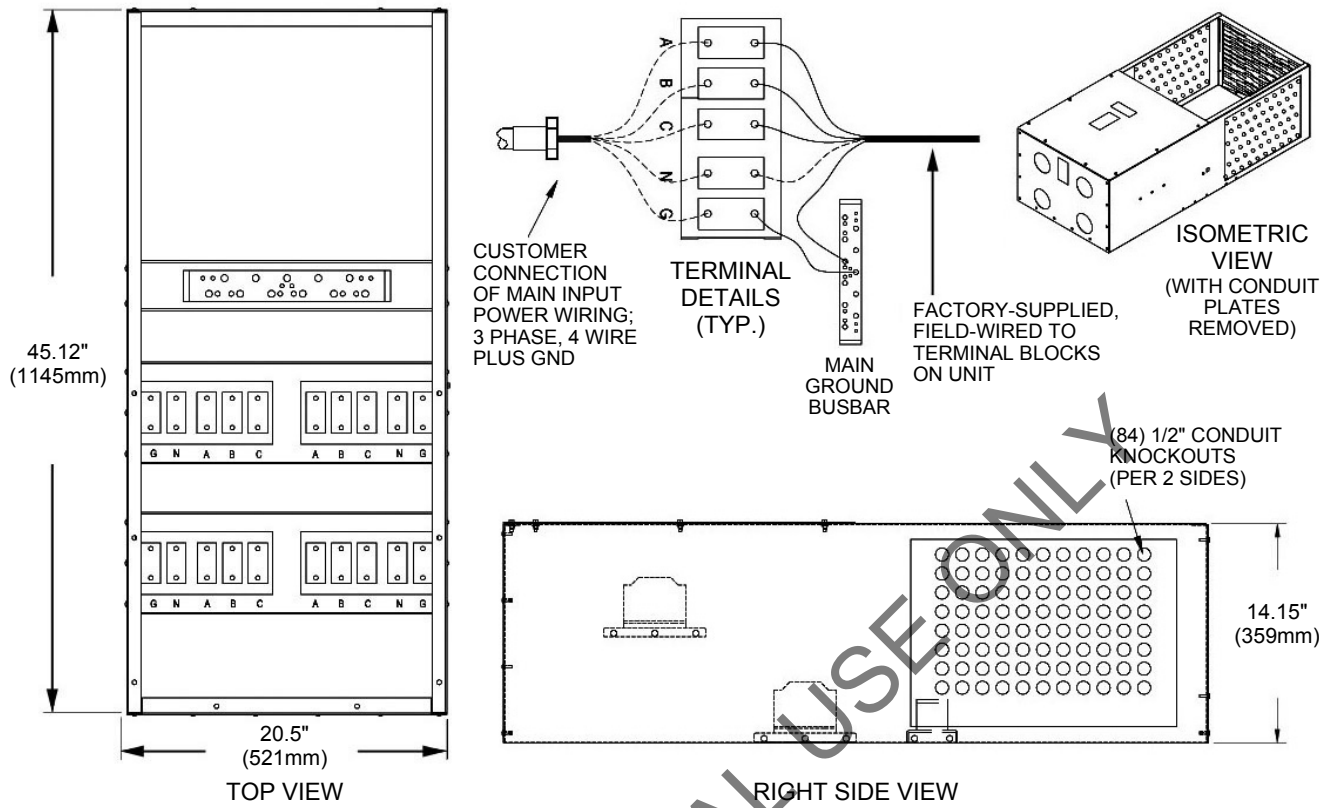

NOTES:

1. TERMINAL BLOCK DUAL STUD FOR 500 KCMIL CONNECTOR.
2. CUSTOMER CONNECTIONS ARE MADE TO THE TERMINAL BLOCKS.

RDC12030
Rev. 3

Figure 17 Junction box installation

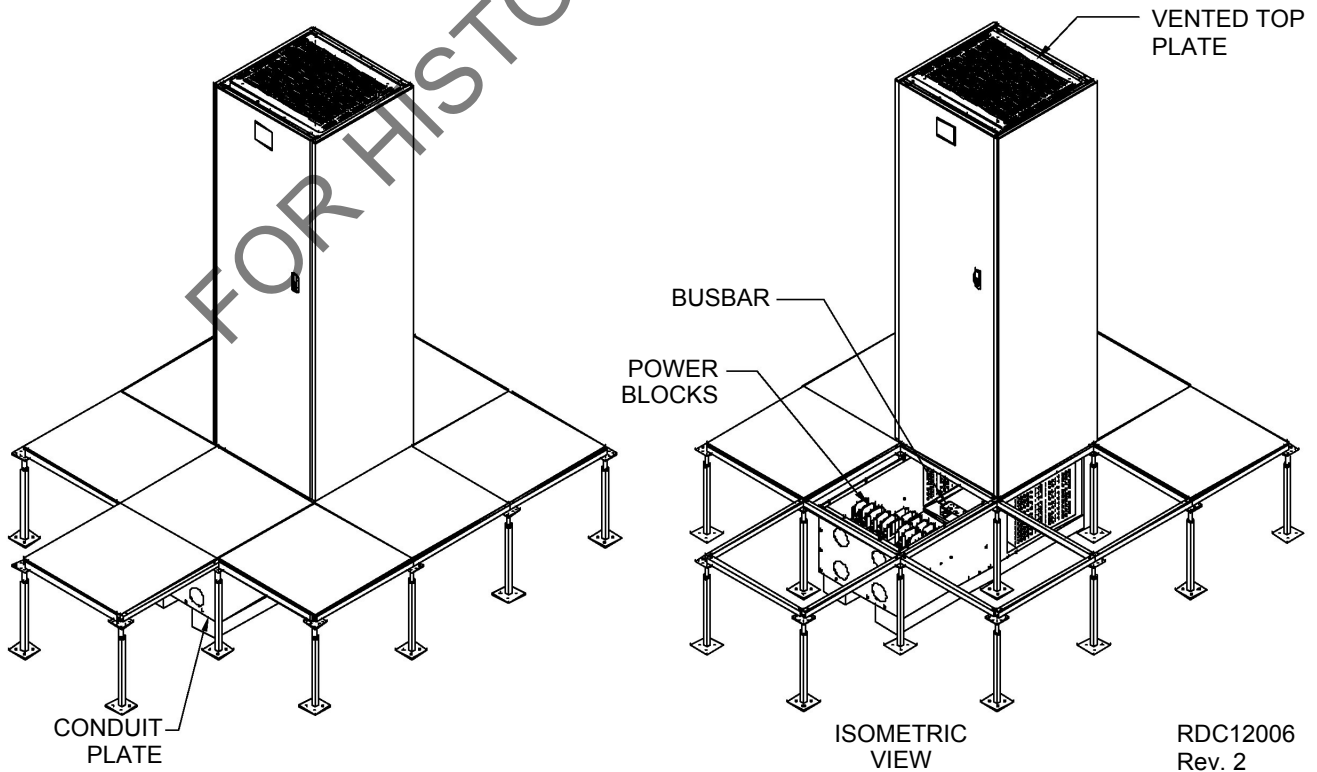

RDC12006
Rev. 2

Figure 18 Dual input junction box with tie breakers

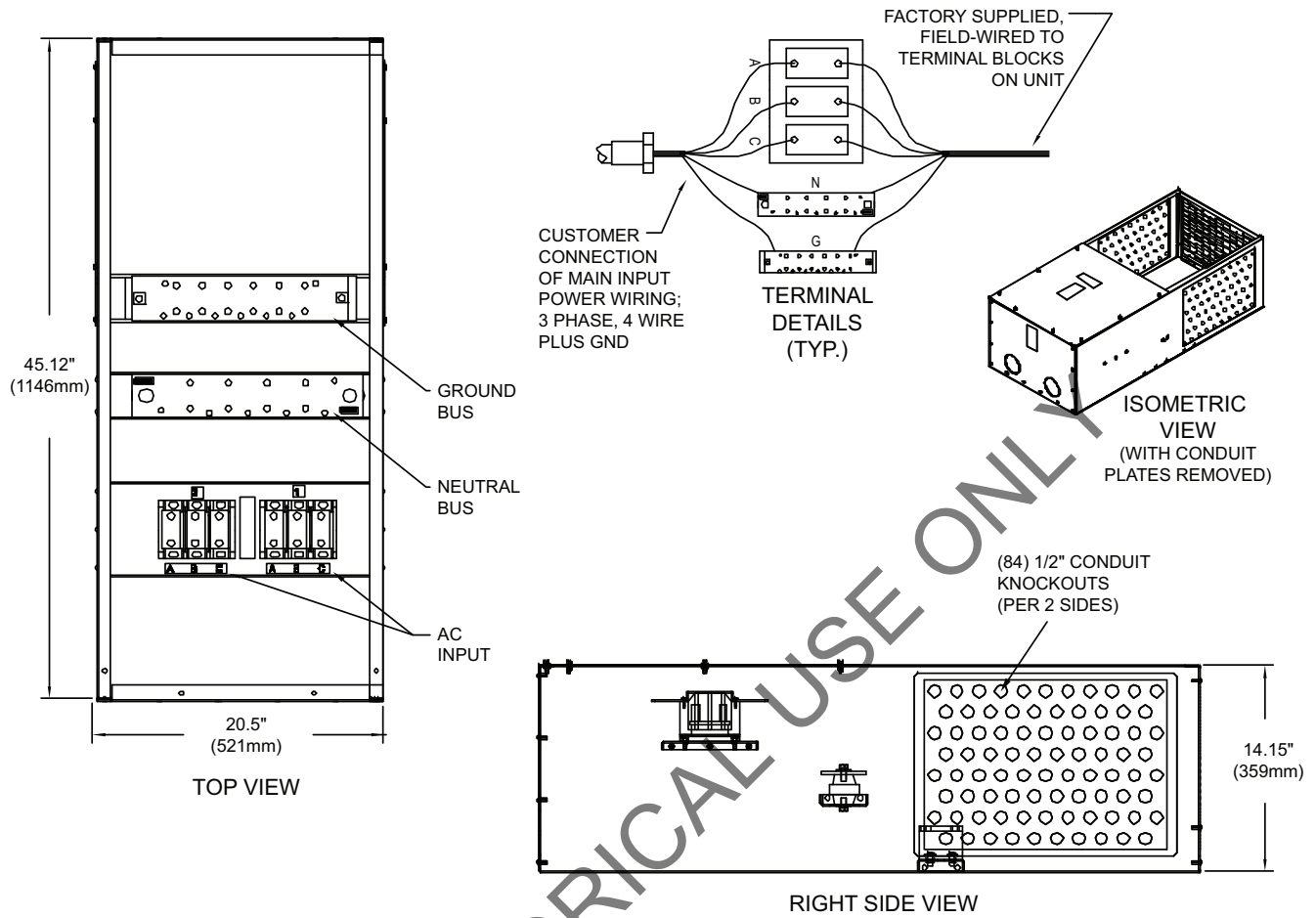

NOTE:
TERMINAL BLOCK DUAL STUD FOR 500 KCMIL CONNECTOR

RDC12031
Rev. 4

FOR HISTORICAL USE ONLY

1.6.3 Conduit Box Installation

The conduit box mounts under the raised floor as an option to simplify customer connections. The conduit box is shipped with the unit. The conduit box dimensions (WxDx H) are: 21-5/8" x 21-5/8" x 11-1/2" (548mm x 548mm x 292mm).

To install the conduit box:

1. Remove one 24" x 24" floor tile.
2. Remove the front and rear doors and the right side panel.
3. Remove the panelboard accent panels and the front and rear kick plates.
4. Position the Liebert RDC over the opening where the tile was removed; the unit will rest on top of the raised floor cross members on all four sides.
5. After the Liebert RDC has been installed on the raised floor, remove the three conduit trays at the bottom of the unit. These are not needed when the conduit box is used and can be discarded. Do NOT remove the conduit trays until the Liebert RDC has been installed on the raised floor.
6. Remove floor tiles as needed for access, but do not remove floor tile cross members.
7. Place the conduit box under the raised floor and use four 1/4" diameter bolts with flat washers, lock washers, one internal tooth washer for grounding and nuts (hardware factory supplied) to attach it to the bottom of the Liebert RDC frame (see **Figure 20**). The internal tooth washer must be in contact with painted surface of base.

Conduit Box Input Power Connections

Attach the input feeder conduits to the sides of the conduit box. Space is provided for one feeder per side. Install cables and attach to the bus bar or power blocks located in the unit.

Reinstall the floor tile, accents, doors, kick plates and side.



WARNING

Verify that incoming line voltage (power) circuits are de-energized and locked out before installing cables or making any connections in the junction box.

Figure 19 Conduit box

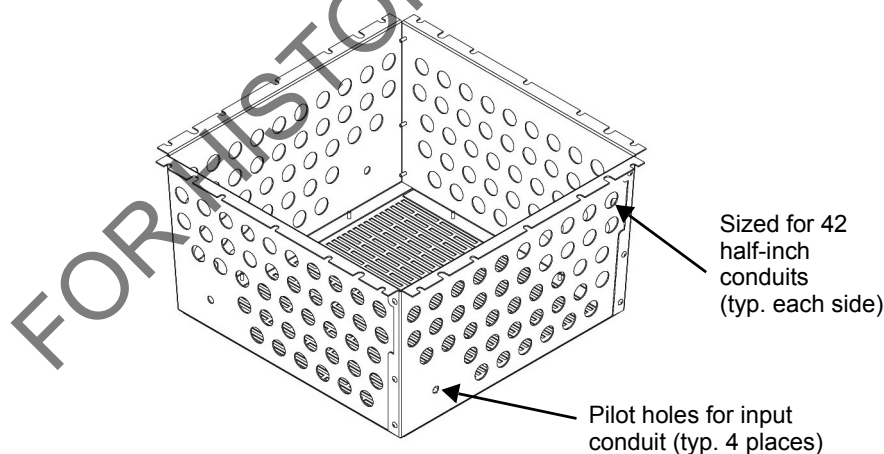
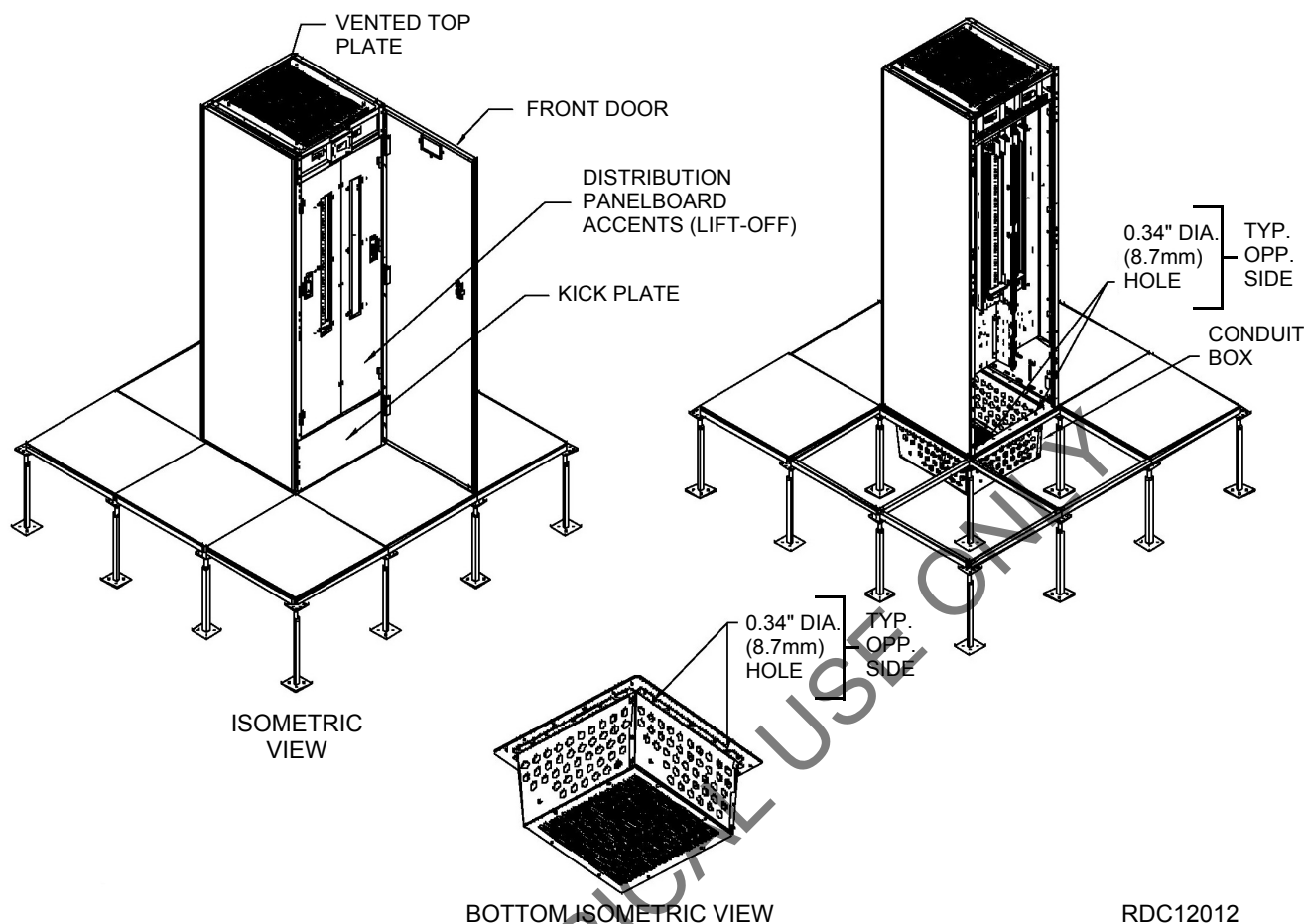

Figure 20 Installation of conduit box



RDC12012

1.7 Output Power Connections

Output panelboards with ground and neutral provisions are provided inside the unit for connecting load(s) as required. (See **Figures 4, 5 and 6**).

Flexible output distribution cables are used in data processing areas under a raised floor. Cable lengths and layout should be well planned:

Cable routes should follow aisles between equipment. This will facilitate access to cables for installation, routine inspection and future changes.

Determine the required cable length by measuring the distance to the load equipment following right-angle paths, rather than diagonally or directly. Always measure to the extreme far side of the equipment with respect to the unit to insure adequate cable length.

Prevent restriction of airflow under the raised floor by running the flexible conduits flat on the sub-floor, in parallel paths.

Initial system output loading should be between 50% and 75% of rated capacity. This allows the addition of future loads without immediately investing in another Liebert RDC.

Balancing of loads is good design practice on any 3-phase system.



WARNING

Verify that incoming line voltage circuits are de-energized and locked out before installing output breakers and cables.

All output cables and connections must comply with the NEC and all other applicable codes.

All output cables without receptacles that are hard-wired to the load equipment must be equipped with a padlock-off accessory for the output circuit breaker. The padlock-off accessory is used to lock out and tag the circuit breaker while service is performed on the hard-wired load equipment in accordance with OSHA safety rules.

1.7.1 Replacing a CT in the CT Module

In the unlikely event a CT in the CT Module should fail, up to six replacement CTs may be installed using a split core CT kit, available separately from your local Emerson representative.

1. Verify that the branch breaker is Off and power is de-energized.
2. Route wiring from the transformer through the panel to the control board.
3. Connect the CT connector to the proper panel location using the first available connection. See **Figure 21** for details:
 - a. For panelboard A use P2 (A1), P3 (A2), P4 (A3).
 - b. For panelboard B use P5 (B1), P6 (B2), P7 (B3).

Ensure all routed wiring is properly secured to the panel with tie wraps.
4. The top piece of the current transformer (CT) is removable by pulling away from the center of the transformer (**Figure 21**, Item 2).
5. Place the main body of the current transformer around the cable, making sure the CT is installed in the direction shown in **Figure 21**, Item 2.
6. Replace the top piece of the CT to complete securing the CT around the cable (**Figure 21**, Item 3), then use the enclosed tie wraps to secure the CT to the cable.

! WARNING

Do not open circuit the secondary windings of current transformers. Failure to follow these instructions may result in serious injury or death.

Figure 21 Electrical field connections for CT Module replacement CTs

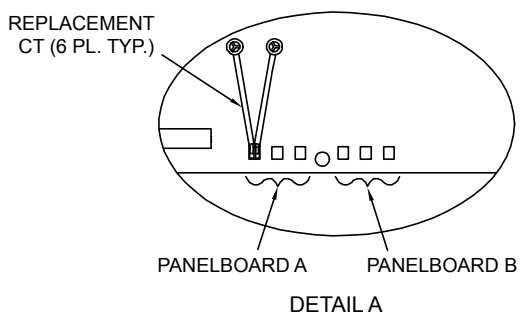
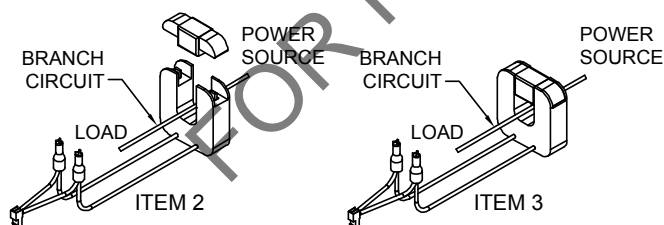
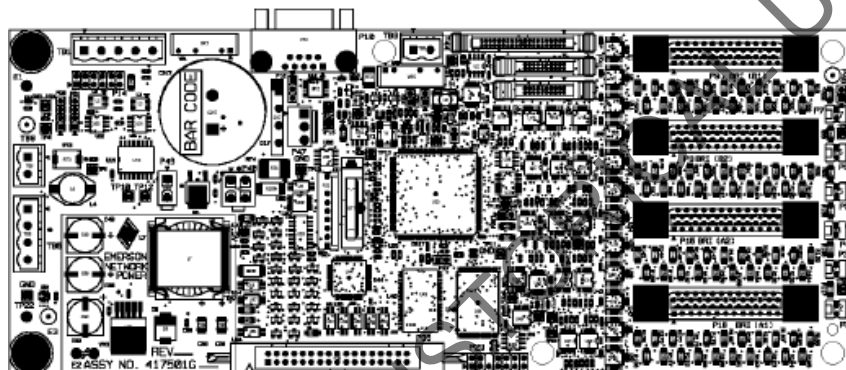

NOTES:

1. REMOVE CT FROM THE BOX. ROUTE WIRING FROM THE TRANSFORMER THROUGH THE PANEL TO THE LDM CONTROL BOARD.
 2. CONNECT THE CT CONNECTOR TO THE PROPER PANEL LOCATION USING THE FIRST AVAILABLE CONNECTION:
 - A. FOR PANELBOARD A USE P2(A1), P3(A2), P4(A3)
 - B. FOR PANELBOARD B USE P5(B1), P6(B2), P7(B3)

ENSURE ALL ROUTED WIRING IS PROPERLY SECURED TO THE PANEL WITH TIE WRAPS.
 3. THE TOP PIECE OF THE CURRENT TRANSFORMER (CT) IS REMOVABLE BY PULLING AWAY FROM THE CENTER OF THE TRANSFORMER (ITEM 2).
 4. PLACE THE MAIN BODY OF THE CURRENT TRANSFORMER AROUND THE CABLE, MAKING SURE THE CT IS INSTALLED IN THE DIRECTION SHOWN (SEE ITEM 2).
 5. REPLACE THE TOP PIECE OF THE CT TO COMPLETE SECURING THE CT AROUND THE CABLE (SEE ITEM 3). USE THE ENCLOSED TIE WRAPS TO SECURE THE CT TO THE CABLE.
- * WARNING: DO NOT OPEN CIRCUIT THE SECONDARY WINDINGS OF CURRENT TRANSFORMERS. FAILURE TO FOLLOW THESE INSTRUCTIONS MAY RESULT IN SERIOUS INJURY OR DEATH.

LDM13004
Rev. 0

Figure 22 Electrical field connections for Liebert Current Plus and LDMF™ communication and summary alarm

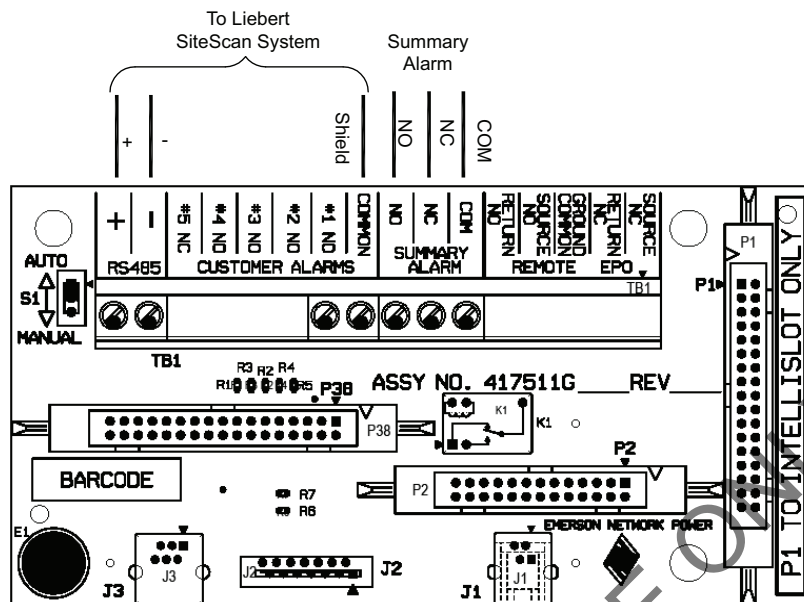

- Notes:
1. The summary alarm contacts are rated for 0 to 30VAC or VDC, 0.5A, 10 watts maximum.
 2. For Liebert SiteScan connection, use #22AWG shielded cable maximum distance 1000ft (300m).
- LDM13011
Rev. 0

1.8 Liebert LDMF Communication

Connecting locally to the Liebert LDMF Monitoring option requires a female-to-female (F-F) DB9 null modem cable. There will be an external port on the Liebert RDC labeled LDMF SETUP. Connect the DB9 null modem cable to a local PC. Once connected you may run any of the provided software tools that can be downloaded from the Liebert Web site, www.liebert.com (see the Liebert LDMF user manual, SL-20200, for details on downloading and using the software).

1.8.1 LDMF Setup Port Connection

The local LDMF Setup port is **not** intended to be a service terminal or hyperterminal connection. It is intended only for use of the Liebert LDMF software tools provided.

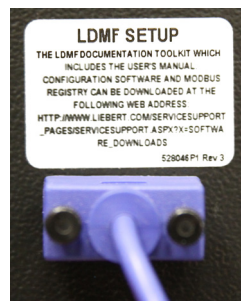

NOTE
Also refer to Figure 12.



NOTE

The images above are intended for illustration only. The location of the external port may vary.



NOTE

Before making any changes to an existing configuration or uploading a file to another Liebert LDMF™ system, make a note of the Software Address. When overwriting an existing configuration file due to changes, modifications or breaker addition/deletion, the Software Address will revert to the value of the file that is loaded. This can lead to incorrect Software Addresses causing Modbus communication errors.

1.8.2 Liebert SiteScan® Web Monitoring Interface

The optional Monitoring interface module allows the Liebert LDMF to communicate with Liebert SiteScan® Web 4.0 or greater. Includes software and graphics which supports up to 168 branch breakers using an Ethernet connection. The monitoring interface is on the back of the Liebert RDC front door with connections for RJ-45 Ethernet and BACnet. See **Figure 14** for location and wiring details.

1.8.3 Summary Alarm

The Liebert LDMF provides Form C (1 NO and 1 NC) summary alarm contacts for remote alarm status. The summary alarm contacts change state upon occurrence of any alarm including warnings and reset when alarm is cleared. The summary alarm connection is on the adapter board (see **Figure 15**, Detail A, and **Figure 22**) marked Summary Alarm (NC) (NO) and (COMM). The contacts are rated at 24VAC @ 1A.

FOR HISTORICAL USE ONLY

2.0 EQUIPMENT INSPECTION AND STARTUP

2.1 Internal Inspection

A detailed internal inspection should be performed after the unit is in place and before it is energized, to ensure trouble-free startup. The same internal inspection should be carried out when performing preventive maintenance.



WARNING

Verify that all incoming power circuits are de-energized and locked out before performing the internal inspection.

Gain access to the internal components of the Liebert RDC by removing the right hand exterior panel.

Visually inspect the wiring and components to be sure they are not damaged.

Check **all** power connections for tightness. Torque requirements of all electrical connections is 80 lb.-in.

Follow the procedures described in **3.0 - Inspection and Startup Checklist** when performing a detailed inspection.

2.2 Startup

Follow the detailed step-by-step checklist in **3.0 - Inspection and Startup Checklist** when installing and starting up the Liebert RDC.

A qualified electrician should be employed to perform the equipment inspection and startup. System startup may be arranged by calling your local Emerson Network Power sales representative or Emerson Network Power Liebert Services. In the USA, call **1-800-543-2378**.

A copy of the appropriate checklist (furnished with the equipment) must be completed, signed, dated and returned to Emerson Network Power. **Warranty coverage of the equipment is not effective unless the Checklist is received by the factory.**



WARNING

Equipment inspection and startup should be performed only by trained personnel.

Hazardous voltages are present during startup procedures.

Electrical safety precautions must be followed throughout inspection and startup.

3.0 INSPECTION AND STARTUP CHECKLIST

Unit Serial Number: _____
 Unit Model Number: _____
 Date: _____

3.1 Inspection



WARNING

All equipment inspection procedures are to be performed with power to the unit turned off and locked out.

Exterior Inspection

- ___ 1. Confirm that the exterior of unit is undamaged
- ___ 2. Confirm that service and ventilation clearances are adequate. (See Figure 3).

Interior Inspection

- ___ 1. Remove accessible exterior panel.
- ___ 2. Inspect all wire and conductor insulation for damage.
- ___ 3. Check all breaker connections for tightness. Retorque if necessary.
- ___ 4. Check all terminal block connections for tightness. Retorque if necessary.
- ___ 5. Remove any foreign objects from the components or the interior area of the unit.
- ___ 6. Check that the intake and exhaust air screens are clean and free of obstructions.
- ___ 7. Replace side panel, leaving access to circuit breakers for the following startup procedure.

FOR HISTORICAL USE ONLY

3.2 Startup



WARNING

Startup procedures should be performed only by qualified personnel. Hazardous voltages are present in the equipment throughout the majority of the startup procedure. Use proper safety equipment. Proceed with caution.

- ___ 1. Make certain that all circuit breakers are in the OFF position and that power to the unit is locked out.



NOTE

Steps 2 through 6 apply to the Input Junction Box. If this installation is not provided with an Input Junction Box, proceed directly to Step 7.

- ___ 2. Remove the cover of the Input Junction Box. Verify proper input power connections to unit, including equipment grounding conductor.
- ___ 3. Turn ON the building power to the junction box. Check the phase rotation at the junction box. Phase rotation should be A, B, C, as indicated.
- ___ 4. Check and record the input voltages at the junction box:

	Input 1	Input 2	Input 3	Input 4
Volts, phase A to phase B =	_____	_____	_____	_____
Volts, phase B to phase C =	_____	_____	_____	_____
Volts, phase C to phase A =	_____	_____	_____	_____

- ___ 5. Turn OFF and lock out the building power to the input junction box.
- ___ 6. Replace the junction box cover.
- ___ 7. Verify proper input power connections to unit, including equipment grounding conductor.
- ___ 8. Turn ON the building input power to the unit.
- ___ 9. Check the phase rotation at the panelboard main breakers. Phase rotation should be A, B, C, left-to-right.
- ___ 10. Check and record the input voltage at each of the panelboard main breakers. Measured voltages should correspond to the unit's nameplate input voltage.

	Panelboard 1	Panelboard 2	Panelboard 3	Panelboard 4
Volts, phase A to phase B =	_____	_____	_____	_____
Volts, phase B to phase C =	_____	_____	_____	_____
Volts, phase C to phase A =	_____	_____	_____	_____

If output voltage is incorrect, check for wiring errors or incorrect input voltage. Contact Liebert Services at **1-800-543-2378** in the USA or the local factory representative for assistance.

- ___ 11. Turn ON the panelboard main breakers.

3.3 Monitoring System Check Out

If the unit is equipped with a Current Monitoring Panel:

- 1. Turn the unit ON.
- 2. Ensure that the LCD display is on. The Monitor Panel displays output and neutral currents for each panelboard (load must be applied to get an accurate reading).

4.0 OPERATING INSTRUCTIONS

4.1 Startup Procedures

Before the unit is placed in service after initial installation, after equipment relocation or after equipment has been de-energized for an extended period of time, perform equipment inspection and startup procedures as detailed in **2.0 - Equipment Inspection and Startup** and in **3.0 - Inspection and Startup Checklist**.

After initial system startup, the following guidelines can be used for standard equipment operation. These guidelines should be reviewed for any special equipment modifications, special site considerations or company policies that may require changes to the standard equipment operation.

4.2 Normal System Shutdown

To perform a normal system shutdown, perform an orderly load equipment shutdown according to the load equipment manufacturer's recommended shutdown sequence. The load equipment can be turned OFF at each piece of load equipment or at the Liebert RDC panelboards (circuit breaker) located behind the unit's front and rear doors. Turn OFF all unit panelboard main breakers. To remove all power from the unit, turn OFF the building power to the unit or junction box.

4.3 Normal System Turn ON

Make certain all unit circuit breakers are in the OFF position. All unit circuit breakers are located behind the front and rear doors. Turn ON building power to the unit. Turn ON the panelboard main circuit breakers. If the circuit breaker has been tripped OFF (instead of being turned OFF), the circuit breaker handle must be moved to the OFF position before being turned ON. Individually turn ON each panelboard circuit breaker following the load equipment manufacturer's startup sequence.

4.4 Current Monitoring Panel

The current monitoring panel consists of a four-digit, high visibility Liquid Crystal Display (LCD) to monitor three phase and neutral currents for each panelboard. Front and rear LCDs are provided with push button switches for selecting currents.

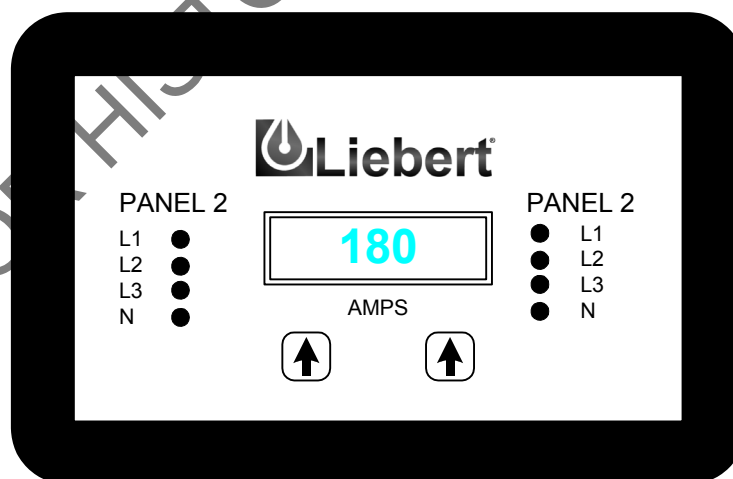

4.5 Current Plus Monitoring

The Liebert RDC has a Current Plus Monitoring (CPM) feature that monitors the current and voltage of the panelboard main circuit breaker. The CPM includes a monochrome Liquid Crystal Display (LCD) with oval bezel that includes power and alarm LEDs, audible alarm and silence push button.

The CPM displays the power parameters and alarms listed below for each panelboard main. The display is mounted on the front and rear doors. The display and switches are accessible without opening the door.

The CPM displays circuit identification, the status of each breaker and the following parameters:

- Voltage
 - Line-to-Line
 - Line-to-Neutral
- Neutral Current
- Ground Current
- kVA
- Power Factor
- Voltage Total Harmonic Distortion (THD)
- Current Total Harmonic Distortion (THD)
- Crest Factor

The CPM annunciates alarm messages for the following conditions. Alarm thresholds for monitored parameters are adjustable through the service port to match site requirements. The alarms and their factory setpoints for the alarms are:

Alarm	Default Setpoint
• Overvoltage	A line-to-line voltage exceeds +6% of nominal
• Undervoltage	A line-to-line or line-to-neutral voltage falls below -13% of nominal
• Neutral Overcurrent	Current exceeds 95% of breaker amps
• Ground Overcurrent	Current exceeds 5 amps
• Phase Overcurrent Warning	Current exceeds 75% of breaker amps
• Phase Overcurrent	Current exceeds 80% of breaker amps
• Summary Alarm	

Summary Alarm - detects and annunciates upon occurrence of any alarm.

Summary Alarm Contacts - The CPM has Form C (1 NO and 1 NC) summary alarm contacts for remote alarm status. The contacts are rated at 24VAC @ 1A. The contacts change state when any alarm or warning occurs and reset when the alarm is cleared.

To facilitate troubleshooting, all alarms are stored in non-volatile memory to protect against erasure by a power outage. Alarms must be manually reset after alarm conditions are corrected.

An event log saves details of up to 128 alarms using a first-in, first-out (FIFO) storage method.

Communication - CPM is supplied with three Liebert IntelliSlot® ports. Three Liebert IntelliSlot cards can be added for customer connection to a Building Management System (BMS). CPM can communicate to a Liebert SiteScan® system using RS-485 connection on the adapter board. See **Figure 22** for connection details.

4.6 Liebert LDMF (Optional)

If the Liebert RDC is equipped with the optional Liebert LDMF, the monitoring unit is On whenever power is supplied to the unit. The Liebert LDMF is factory-configured for 1-pole, 20A branch breakers. Alarms, alarm setpoints, circuit breaker names and circuit breaker ratings are all field-adjustable through the DB9 connector (**LDMF SETUP** port next to the panelboard main circuit breaker).

For more information, refer to **1.8 - Liebert LDMF Communication** for communication options and connections and to the Liebert LDMF user manual, SL-20200, available at the Liebert Web site:

www.liebert.com

The Liebert LDMF has an optional local display that allows users to view monitoring information for the panelboard main circuit breaker as well as each individual branch circuit breaker. Alarm data can be viewed from the local display for up-to-date breaker status.

Figure 23 Liebert LDMF optional local display



5.0 MAINTENANCE

5.1 Repair

Even the most reliable equipment may fail. Liebert Services is at your service to ensure fast repair of your unit and minimum down-time of your installation.

WARNING

Only qualified service personnel should perform maintenance on the Liebert RDC.

Standard electrical troubleshooting procedures should be used to isolate problems in the unit. If there are questions, don't hesitate to contact Liebert Services.

Repair or replacement of standard items, such as circuit breakers and fuses can be either handled by qualified electricians or referred to Liebert Services.

Repairs related to the monitoring system should be referred to Liebert Services.

To contact Liebert Services for information or repair service in the USA, call 1-800-543-2378.

5.2 Inspection & Cleaning

Air circulation through the cabinet may cause dust to accumulate on internal components. Cleaning should be done as necessary during electrical inspections.

Annual general system inspections, cleaning and operation checks are recommended to ensure system performance and long service life.

WARNING

Only qualified service personnel should perform maintenance on the Liebert RDC. All voltage sources to the unit must be disconnected before inspecting or cleaning within the cabinet.

5.2.1 Inspection Schedule

- It is difficult to establish a schedule for periodic cleaning because conditions vary from site to site. Inspections after the first 24 hours, after 30 days and after 6 months of operation should help determine a pattern for the inspection schedule.
- Electrical connections and component mountings should be inspected after the first 24 hours, after 30 days and after 6 months of operation. Inspections should be conducted annually thereafter.
- Ventilation openings and grilles should be inspected and cleaned every 6 months to one year.
- A complete inspection and operational checkout should be performed annually. This is best done by performing the inspection and startup procedure as detailed in **3.0 - Inspection and Startup Checklist**.
- Liebert Services offers a complete range of preventive maintenance services. These include thorough equipment performance checks and calibration of electronics. Contact Liebert Services in the USA (1-800-543-2378) for details.

FOR HISTORICAL USE ONLY

FOR HISTORICAL USE ONLY

Technical Support / Service

Web Site

www.liebert.com

Monitoring

liebert.monitoring@emerson.com

800-222-5877

Outside North America: +00800 1155 4499

Single-Phase UPS & Server Cabinets

liebert.upstech@emerson.com

800-222-5877

Outside North America: +00800 1155 4499

Three-Phase UPS & Power Systems

800-543-2378

Outside North America: 614-841-6598

Environmental Systems

800-543-2778

Outside the United States: 614-888-0246

Locations

United States

1050 Dearborn Drive

P.O. Box 29186

Columbus, OH 43229

Europe

Via Leonardo Da Vinci 8

Zona Industriale Tognana

35028 Piove Di Sacco (PD) Italy

+39 049 9719 111

Fax: +39 049 5841 257

Asia

29/F, The Orient Square Building

F. Ortigas Jr. Road, Ortigas Center

Pasig City 1605

Philippines

+63 2 687 6615

Fax: +63 2 730 9572

While every precaution has been taken to ensure the accuracy and completeness of this literature, Liebert Corporation assumes no responsibility and disclaims all liability for damages resulting from use of this information or for any errors or omissions.

© 2014 Liebert Corporation

All rights reserved throughout the world. Specifications subject to change without notice.

© Liebert is a registered trademark of Liebert Corporation.

All names referred to are trademarks

or registered trademarks of their respective owners.

SL-30750_REV4_08-14

Emerson Network Power

Liebert

www.emerson.com