

Liebert Challenger™ 3000

Installation Manual - 3 & 5 Tons, 50 & 60Hz



FOR HISTORICAL USE ONLY

FOR HISTORICAL USE ONLY

TABLE OF CONTENTS

1.0	INTRODUCTION	1
1.1	System Descriptions	1
1.1.1	Self Contained Systems	1
1.1.2	Chilled Water Models	1
1.1.3	Split Systems	1
2.0	INSTALLATION	2
2.1	Room Preparation	2
2.2	Equipment Inspection	2
2.3	Location Considerations	2
2.4	Equipment Handling	2
2.4.1	Handling With Skid	2
2.4.2	Removal of Skid	3
2.5	Piping Considerations	6
2.5.1	Drain Line	6
2.6	Electrical Connections	12
2.7	Balancing the Air Distribution	13
2.7.1	Under-Floor Discharge Systems	13
2.7.2	Ducted Applications	14
2.7.3	Plenum Installation	14
2.8	Checklist for Completed Installation	14
3.0	AIR COOLED MODELS	16
3.1	Condenser Location	16
3.2	Electrical Connections	16
3.2.1	Line Voltage	16
3.2.2	Low Voltage	16
3.2.3	Lee-Temp/Flood Back Head Pressure Control Condensers	16
3.3	Refrigerant Piping	18
3.4	Fan Speed Control Systems	19
3.4.1	Materials Supplied	19
3.4.2	Dehydration/Leak Test and Charging Procedures for R22 (standard) or R407C (Optional) ..	20
3.4.3	Charging	22
3.5	Lee-Temp/Flood Back Head Pressure Control Systems	22
3.5.1	Piping	22
3.5.2	Materials Supplied	23
3.5.3	Dehydration/Leak Test and Charging Procedures for R22 (Standard) or R407C (Optional) ..	23
3.5.4	Charging	24
4.0	WATER COOLED MODELS	26
4.1	Piping Considerations	26
4.2	Condenser	26
4.3	Water Regulating Valve	28
4.3.1	Standard Valve - 150psig (1034kPa) System for 3 & 5 Ton Units (Johnson Controls Valve) High Pressure Valve - 350psig (2413kPa) System for 5 Ton Units (Johnson Controls Valve)	28
4.3.2	High Pressure Valve - 350 psig (2413 kPa) System for 3 Ton Units (Metrex Valve)	29
4.3.3	Testing Valve Function	29
5.0	GLYCOL/GLYCOOL COOLED MODELS	30
5.1	Drycooler Location	30

5.2	Drycooler Installation	30
5.3	Electrical Connections	30
5.3.1	Line Voltage	30
5.3.2	Low Voltage	30
5.3.3	Pump and Drycooler	30
5.4	Glycol Piping	31
5.4.1	Expansion Tanks, Fluid Relief Valves and Other Devices	32
5.5	Filling Instructions	32
5.5.1	Preparing the System for Filling	32
5.5.2	Glycol Solutions	33
5.5.3	Filling the System	34
5.6	Condenser	39
5.7	Glycol Regulating Valve	39
5.7.1	Standard Valve - 150psig (1034kPa) System for 3 & 5 Ton Units (Johnson Controls Valve) High Pressure Valve - 350psig (2413kPa) System for 5 Ton Units (Johnson Controls Valve)	39
5.7.2	High Pressure Valve - 350 psig (2413 kPa) System for 3 Ton Units (Metrex Valve)	39
5.7.3	Testing Valve Function	39
6.0	CHILLED WATER MODELS	40
6.1	Piping Considerations	40
7.0	SPLIT SYSTEM MODELS	42
7.1	Location Considerations	42
7.1.1	Air Cooled Condensing Units	42
7.1.2	Water/Glycol Cooled Condensing Units	42
7.2	Electrical Connections	42
7.2.1	Line Voltage	42
7.2.2	Low Voltage	42
7.3	Piping Considerations	43
7.3.1	Refrigerant Loop	43
7.3.2	Quick Connect Fittings	46
7.4	Outdoor Air Cooled Condensing Units	47
7.5	Centrifugal Air Cooled Condensing Units	52
7.5.1	Installing the Indoor Condensing Unit	52
7.5.2	Ducting	54
7.6	Water and Glycol Cooled Condensing Units	60
7.6.1	Piping Considerations	60
7.6.2	Condenser Water Requirements	60
7.6.3	Regulating Valve	60
7.6.4	Glycol Systems	60
8.0	R407C REFRIGERANT	65
8.1	Calculating Subcooling	66

FIGURES

Figure 1	Removing Challenger from skid	3
Figure 2	Upflow (BU) cabinet dimensions	4
Figure 3	Downflow (BF) cabinet dimensions	5
Figure 4	Piping connections for air cooled units	7
Figure 5	Piping connections for split system fan coil units	8
Figure 6	Piping connections for water/glycol and GLYCOOL units	9
Figure 7	Piping connections for chilled water self-contained units	10
Figure 8	Electrical connections	12
Figure 9	Air cooled condensers	17
Figure 10	Air cooled fan speed control general arrangement	21
Figure 11	Air cooled, Lee-Temp general arrangement	25
Figure 12	Water cooled general arrangement	27
Figure 13	Johnson Controls valve adjustment	28
Figure 14	Metrex Valve adjustment	29
Figure 15	Drycoolers and pump packages	35
Figure 16	Pump packages—expansion tank	36
Figure 17	Glycol general arrangement	37
Figure 18	GLYCOOL general arrangement	38
Figure 19	Chilled water general arrangement - Upflow (BU)	40
Figure 20	Chilled water general arrangement - downflow (BF) models	41
Figure 21	Refrigerant piping diagram	45
Figure 22	Outdoor air cooled condensing unit—horizontal air discharge models	47
Figure 23	Outdoor air cooled condensing unit—top air discharge models	49
Figure 24	Electrical field connections, prop fan condensing module	51
Figure 25	Detail of ceiling hanging bracket	53
Figure 26	2 and 3 ton centrifugal air cooled condensing unit dimensional data & piping connections	55
Figure 27	3 ton centrifugal air cooled condensing unit (con't.)	56
Figure 28	5 ton centrifugal air cooled condensing unit dimensional data	57
Figure 29	5 ton centrifugal air cooled condensing unit dimensional data (con't.)	58
Figure 30	Split systems general arrangement	59
Figure 31	2 and 3 ton water/glycol cooled condensing unit	61
Figure 32	3 ton water/glycol cooled condensing unit (con't.)	62
Figure 33	5 ton water/glycol cooled condensing unit dimensional data	63
Figure 34	5 ton water/glycol cooled condensing unit (con't.)	64

TABLES

Table 1	Unit net weight	3
Table 2	Piping connection size.	6
Table 3	Recommended free area ft ² (m ²) for grilles or perforated panels at output velocities of 550 and 600 fpm (2.8 and 3.1 m/s)	13
Table 4	Air cooled condenser statistics	17
Table 5	Recommended line sizes — OD copper (inches)*	18
Table 6	Equivalent lengths (feet) for various pipe fittings	19
Table 7	Indoor unit refrigerant charge lbs (kg) R22 or R407C (per unit serial tag).	19
Table 8	Line charges - refrigerant per 100 ft (30 m) of Type "L" copper tube.	19
Table 9	Condenser refrigerant (per serial tag)	19
Table 10	Refrigerant control settings psi (kPa)	22
Table 11	Refrigerant control settings psi (kPa)	24
Table 12	Refrigerant control settings psi (kPa)	29
Table 13	Room dew point temperatures	31
Table 14	Indoor unit glycol volume approximate gallons (liters) max.	32
Table 15	Volume in standard Type "L" copper piping	32
Table 16	Ethylene glycol concentrations.	33
Table 17	Mounting hole dimensional data	36
Table 18	Drycooler data	36
Table 19	Glycol pump data*	36
Table 20	Refrigerant control settings psi (kPa)	39
Table 21	Unit refrigerant charge	44
Table 22	Line charges - refrigerant per 100 ft (30 m) of Type "L" copper tube.	44
Table 23	Recommended refrigerant lines (R22 or R407C) sizes OD copper	44
Table 24	Line coupling sizes	44
Table 25	Equivalent lengths (feet) for various pipe fittings	45
Table 26	Horizontal air discharge cabinet and floor planning dimensional data.	48
Table 27	Horizontal air discharge piping and electrical connection data	48
Table 28	Cabinet and floor planning dimensional data - prop fan condensing modules, top air discharge	50
Table 29	Piping and electrical connections - top air discharge	50
Table 30	Indoor centrifugal condensing unit	52
Table 31	Airflow CFM (CMH)	54
Table 32	Water and glycol cooled condensing unit data	60
Table 33	R407C pressure/temperature chart for operation and superheat (discharge/hot gas and suction gas)	65
Table 34	R407C pressure/temperature chart for subcooling only (liquid measurements).	66

1.0 INTRODUCTION

1.1 System Descriptions

Challenger 3000™ environmental control systems are available in three main system configurations:

- self contained system with a scroll compressor in the room unit
- self contained chilled water system
- split system with an evaporator section and a remote condensing unit

All three types are available in upflow or downflow configurations. The standard upflow configuration is front return. All models require three-phase power. Units are available in 208, 230, 460, or 575 V, 60 Hz; and 200, 230 or 380/415 V, 50 Hz.

The following features are included as standard in all room units regardless of the type of system: A-frame coil (V-frame on upflows), infrared humidifier, finned tubular stainless steel electric reheat, 2" filter, individual high voltage fused protection, and fan assembly.

Each configuration can operate with either Advanced Microprocessor Controls (A), or Advanced Microprocessor Controls with Graphics (G). A brief description of each, including operational differences, is listed below. Check model numbers to see what is supplied with your unit.

1.1.1 Self Contained Systems

Air Cooled Models

Complete refrigeration system including hot gas bypass and crankcase heater with standard condenser and fan speed control for 95°F (35°C) ambient at sea level.

Water Cooled Models

Complete refrigeration system including hot gas bypass with water/glycol cooled condenser and two-way water regulating valve with bypass.

Glycol Cooled Models

The water cooled model as described above plus pump package and 95°F (35°C) design ambient dry-cooler.

GLYCOOL Models (5 Ton Only)

Complete refrigeration system including hot gas bypass with glycol condenser and three-way water regulating valve plus an integrally piped Econ-O-Coil with three-way modulating control valve.

1.1.2 Chilled Water Models

Chilled Water models include chilled water piping, three-way modulating valve, and actuator assembly.

1.1.3 Split Systems

Each Air Cooled split system consists of an evaporator section and one of the following condensing units.

Prop Fan

Includes scroll compressor, condenser coil, prop fan, high pressure switch, and Lee-Temp head pressure control. Unit is designed for outdoor location.

Centrifugal Fan

Includes scroll compressor, condenser coil, centrifugal blower assembly, high pressure switch, head pressure control valve, Lee-Temp receiver and liquid line solenoid valve. Unit must be mounted indoors. Duct flanges are optional.

Each Water Cooled split system consists of an evaporator section and a water/glycol condensing unit, which includes scroll compressor, coaxial condenser, water regulating valve, and high pressure switch. Design pressure is 150 psi (1034 kPa) as standard and 350 psi (2413 kPa) as optional.

Each Glycol Cooled split system consists of an evaporator section, a water/glycol condensing unit (as described above), a pump package, and a 95°F (35°C) design ambient drycooler.

2.0 INSTALLATION

2.1 Room Preparation

The room should be well insulated and must have a sealed vapor barrier. The vapor barrier in the ceiling can be a polyethylene film type. Use a rubber or plastic base paint on concrete walls and floors. Doors should not be undercut or have grilles in them.

Outside (or fresh) air should be kept to an absolute minimum. Outside air adds to the heating, cooling, humidifying and dehumidifying loads of the site. It is recommended that outside air be kept below 5% of the total air circulated in the room and be preconditioned.

2.2 Equipment Inspection

Upon arrival of the unit, inspect all items for visible and concealed damage. Damage should be immediately reported to the carrier and a damage claim filed with a copy sent to Liebert or to your sales representative.

2.3 Location Considerations

The unit can sit on top of an accessible elevated flooring system. It may be necessary to furnish additional pedestal support below the unit to ensure maximum structural support (see **Table 1**). A separate floor stand for the unit may be used as support, independent of the elevated floor and installed prior to the flooring system.

Provide approximately 34" (864 mm) service clearance on the front of the unit.



NOTE

GLYCOOL units require 34" (864 mm) service clearance on the right side of the unit in addition to front service clearance.

Avoid placing units in an alcove or at the extreme end of a room that has a high aspect ratio (long, narrow room). Ducted units can be placed in room corners or ends as long as front access is maintained. Placing units too close together will reduce the effectiveness of the air distribution.



NOTE

Locate and remove shipping screw on fan motor base.

2.4 Equipment Handling



WARNING

The instructions listed below are to be adhered to when handling this unit with or without the skid. There is the potential for this unit to tip over if handled improperly, which will cause damage to the unit and could cause injury or death to the unit handler(s).

2.4.1 Handling With Skid

- Always keep the unit upright, indoors and protected from damage.
- If possible, transport the unit using a fork lift; otherwise, use a crane with belts or cables, avoiding pressing on the top edges of the packaging.
- If using a fork lift, make sure the forks, if adjustable, are spread to the widest allowable distance to still fit under the skid.



CAUTION

While on the skid, the unit is too tall to fit through a standard height doorway (83 inches or 2108 mm tall). Any attempt to move the unit, while on the skid, through a standard doorway will cause damage to the unit.

2.4.2 Removal of Skid

- Remove the plywood skirting that keeps the skid and unit in place.
- Raise the Challenger 3000 off the skid. **Liebert recommends using a fork lift (see Figure 1) or similar machine to ensure that the unit is lifted properly.**
- Once the unit is raised, the skid can be removed.

Figure 1 Removing Challenger from skid

Remove plywood skirting holding unit and skid in place.

Raise unit with fork lift or similar machine.

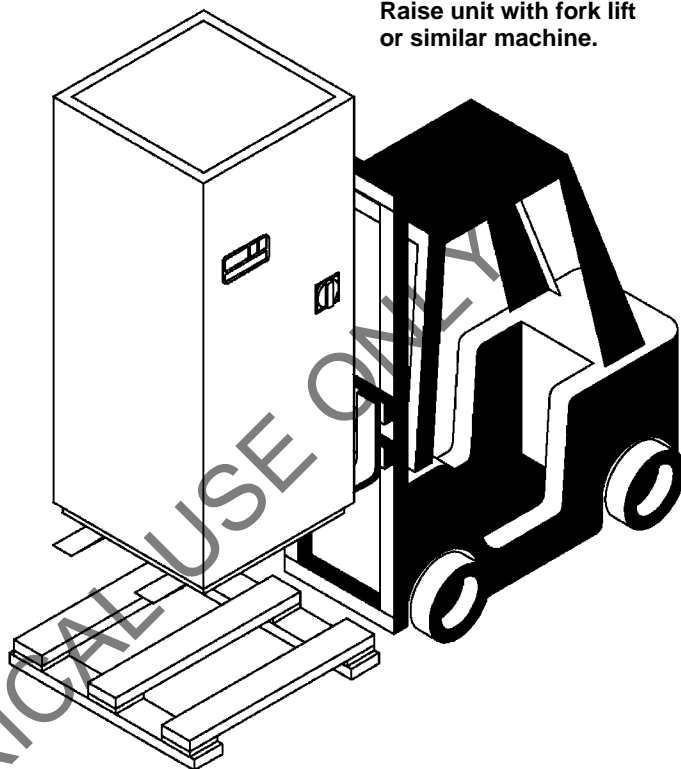
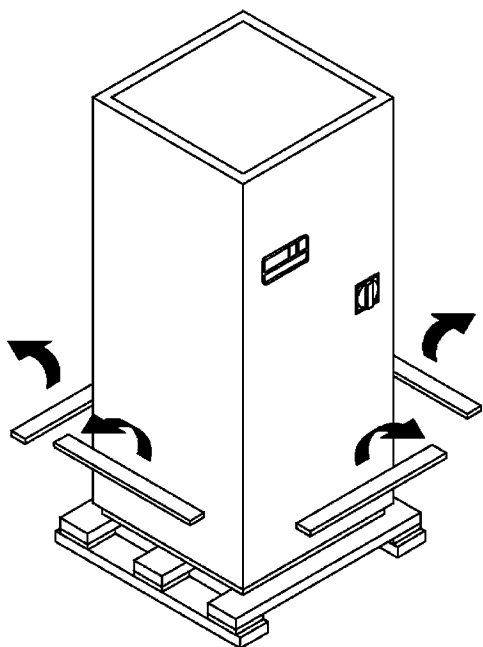
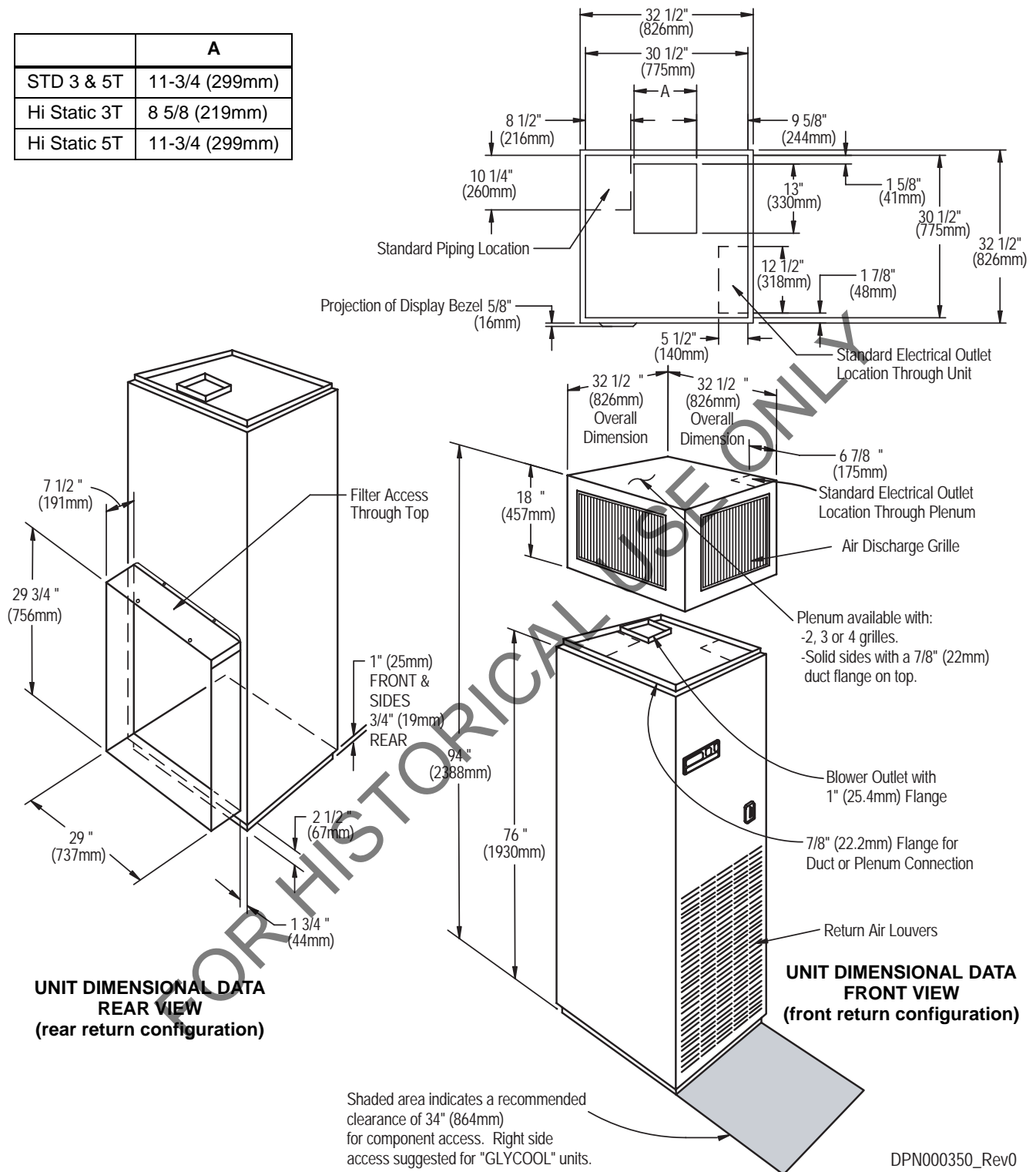

Table 1 Unit net weight

Model	Lbs (kg)
036E/035E	535 (243)
060E/059E	545 (247)
042A/040A	595 (270)
067A/065A	640 (291)
046WG/045WG	640 (291)
071WG/070WG	710 (322)
061G/058G	750 (341)
068C/072C	545 (247)
102C/101C	555 (252)

Figure 2 Upflow (BU) cabinet dimensions

	A
STD 3 & 5T	11-3/4 (299mm)
Hi Static 3T	8 5/8 (219mm)
Hi Static 5T	11-3/4 (299mm)



DPN000350_Rev0

Figure 3 Downflow (BF) cabinet dimensions

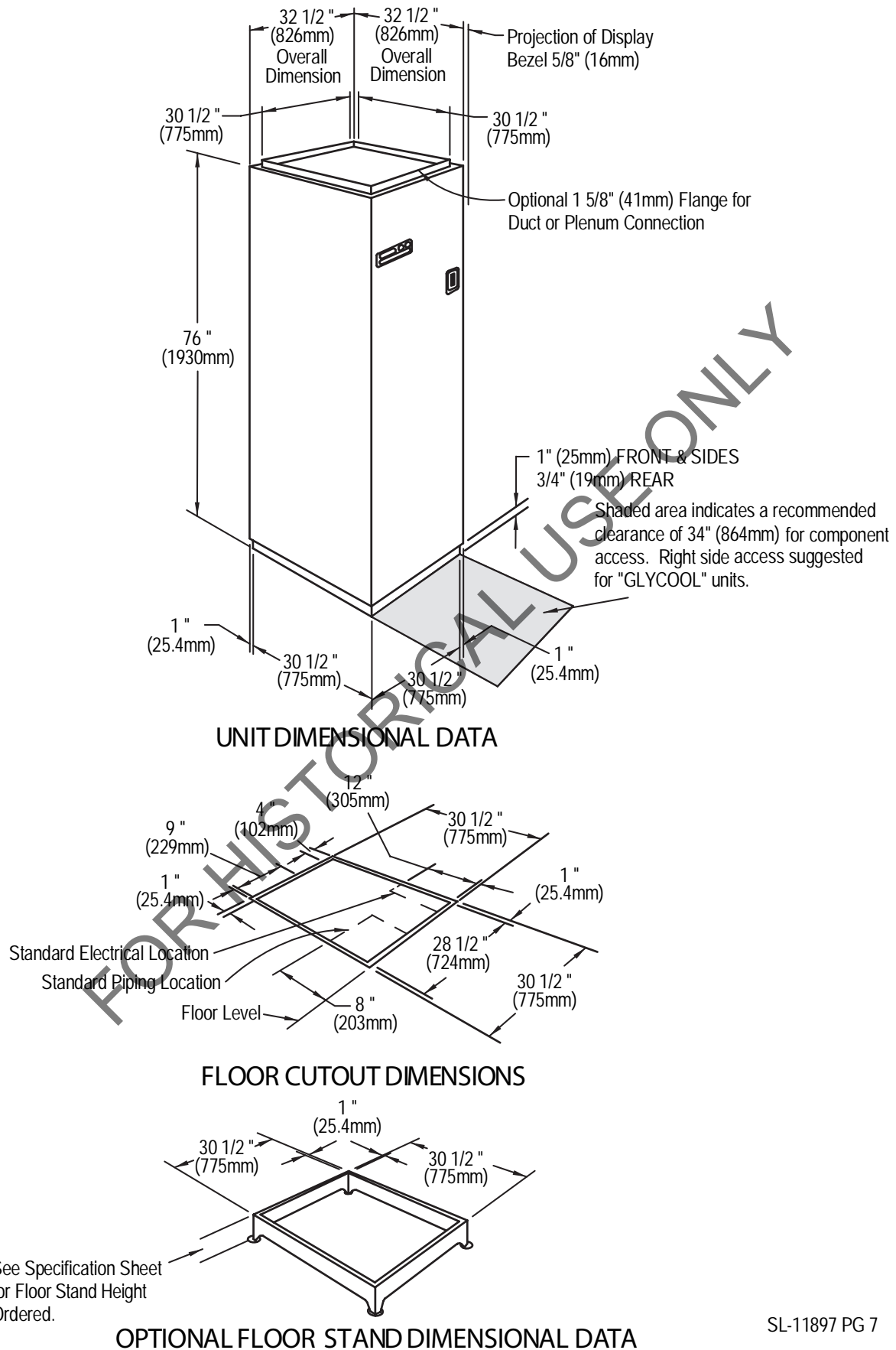

2.5 Piping Considerations

All piping below the elevated floor must be located so that it offers the least resistance to air flow. Careful planning of the piping layout under the raised floor is required to prevent the air flow from being blocked. When installing piping on the subfloor, it is recommended that the pipes be mounted in a horizontal plane rather than stacked one above the other. Whenever possible, the pipes should be run parallel to the air flow.

Condensate pumps for downflow units are shipped separately to be field-installed under the raised floor. Pump height is 11 inches (279 mm).

2.5.1 Drain Line

A 3/4" (19.1 mm) female pipe thread (FPT) connection is provided for the evaporator coil condensate drain. This drain line also drains the humidifier, if applicable. The drain line must be located so it will not be exposed to freezing temperatures. The drain should be at least the full size of the drain connection and pitched a minimum of 1/8" per ft. (11 mm per meter).



NOTE

This line may contain boiling water. Select appropriate drain system materials.

The drain line must include one and only one trap. Units without a condensate pump have a factory-supplied trap in the unit, so a field trap should not be added. Units with a condensate pump will require a field-supplied trap downstream from the pump. The drain line must comply with all applicable codes.

Table 2 Piping connection size

Air Cooled Unit Connection Sizes—in.				
Model No. BF/BU (50 Hz)	Liquid Line O.D. Copper L	Hot Gas Line OD Copper HG		
042A (040A)	3/8	5/8		
067A (065A)	1/2	7/8		
Split System Fan Coil Unit Connection Sizes—in.				
Model No. BF/BU (50 Hz)	Liquid Line L	Suction Line SC		
036E (035E)	5/8 - 18 Female (#6 QC)	1-1/8 - 12 Female (#11 QC)		
060E (059E)	1/2 OD Cu	1-1/8 OD Cu		
All Units: Connection Sizes—in.				
Humidifier Line OD Copper H	Condensate Drain Line C	Condensate Pump Line OD Copper P	Hot Water Reheat OD Copper	
1/4	3/4 FPT	1/2	Supply HWS	Return HWR
			5/8	5/8
Water/Glycol Cooled Unit Connection Sizes—inches				
Model No. BF/BU (50 Hz)	Supply Line S	Return Line R		
046WG (045WG)	7/8	7/8		
071WG (070WG)	1-1/8	1-1/8		
GLYCOOL Unit Connection Sizes—in.				
Model No. BE/BK (50 Hz)	Supply Line S	Return Line R		
061G (058G)	1-1/8	1-1/8		
Chilled Water Unit Connection Sizes—in.				
Model No. BF/BU (50 Hz)	Supply Line CWS	Return Line CWR		
068C (072C)	1-1/8	1-1/8		
102C (101C)	1-1/8	1-1/8		

Figure 4 Piping connections for air cooled units

DOWNFLOW (BF) MODELS

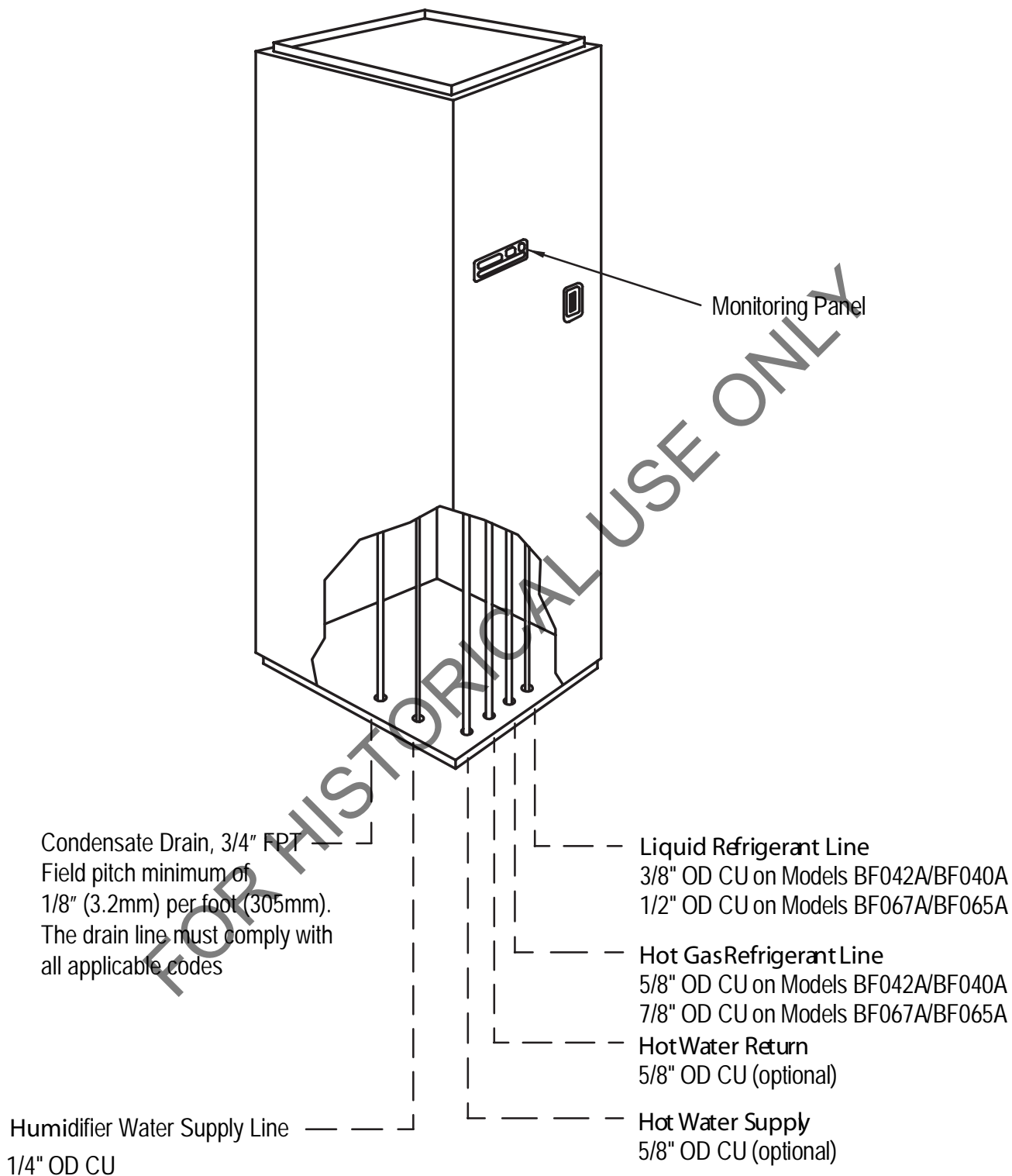

PIPING OUTLET LOCATIONS
(See Cabinet and Floor Planning
Dimensional Data for Piping
Opening Sizes.)

Figure 5 Piping connections for split system fan coil units

UPFLOW (BU) MODELS

Piping outlet locations through the plenum are the same as the unit. See below for descriptions and connection sizes.

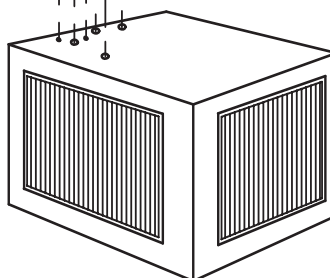

Humidifier Water Supply Line
1/4" OD CU

Hot Water Return
5/8" OD CU (optional)

Suction Refrigerant Line
#11 Quick Connect on Models BU036E/BU035E
1 1/8" OD CU on Models BU060E/BU059E

Liquid Refrigerant Line
#6 Quick Connect on Models BU036E/BU035E
1/2" OD CU on Models BU060E/BU059E

Condensate Pump Line
1/2" OD CU
Used only if optional condensate pump is ordered.

Hot Water Supply
5/8" OD CU (optional)

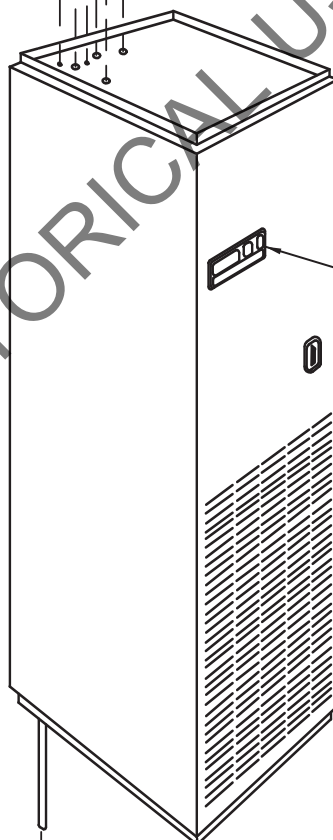

Monitoring Panel

Condensate Drain
3/4" FPT
Field pitch a min. of 1/8" (3.2mm) per ft. (305mm). Units without a condensate pump have a factory-supplied trap in the unit, so a field trap should not be added. Units with a condensate pump will require a field-supplied trap downstream from the pump. The drain line must comply with all applicable codes. (If condensate pump is ordered piping is out top of unit).

PIPING OUTLET LOCATIONS
(See Cabinet and Floor Planning Dimensional Data for Piping Opening Sizes.)

SL-11900 PG 8

Figure 6 Piping connections for water/glycol and GLYCOOL units

DOWNFLOW (BF, BE) MODELS

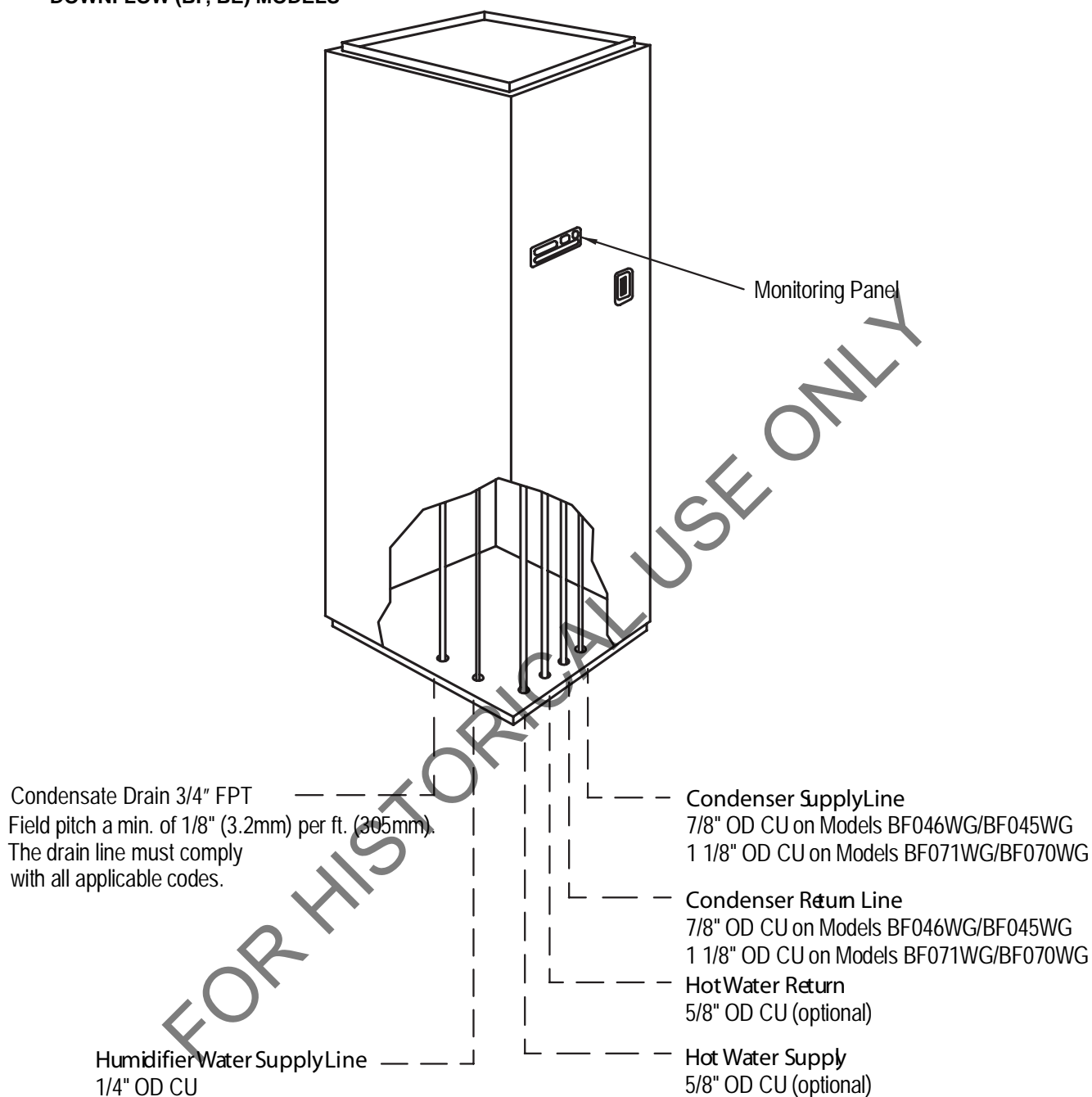

PIPING OUTLET LOCATIONS
(See Cabinet and Floor Planning
Dimensional Data for Piping Opening Sizes.)

SL-11898 PG 10

Figure 7 Piping connections for chilled water self-contained units

UPFLOW (BU) MODELS

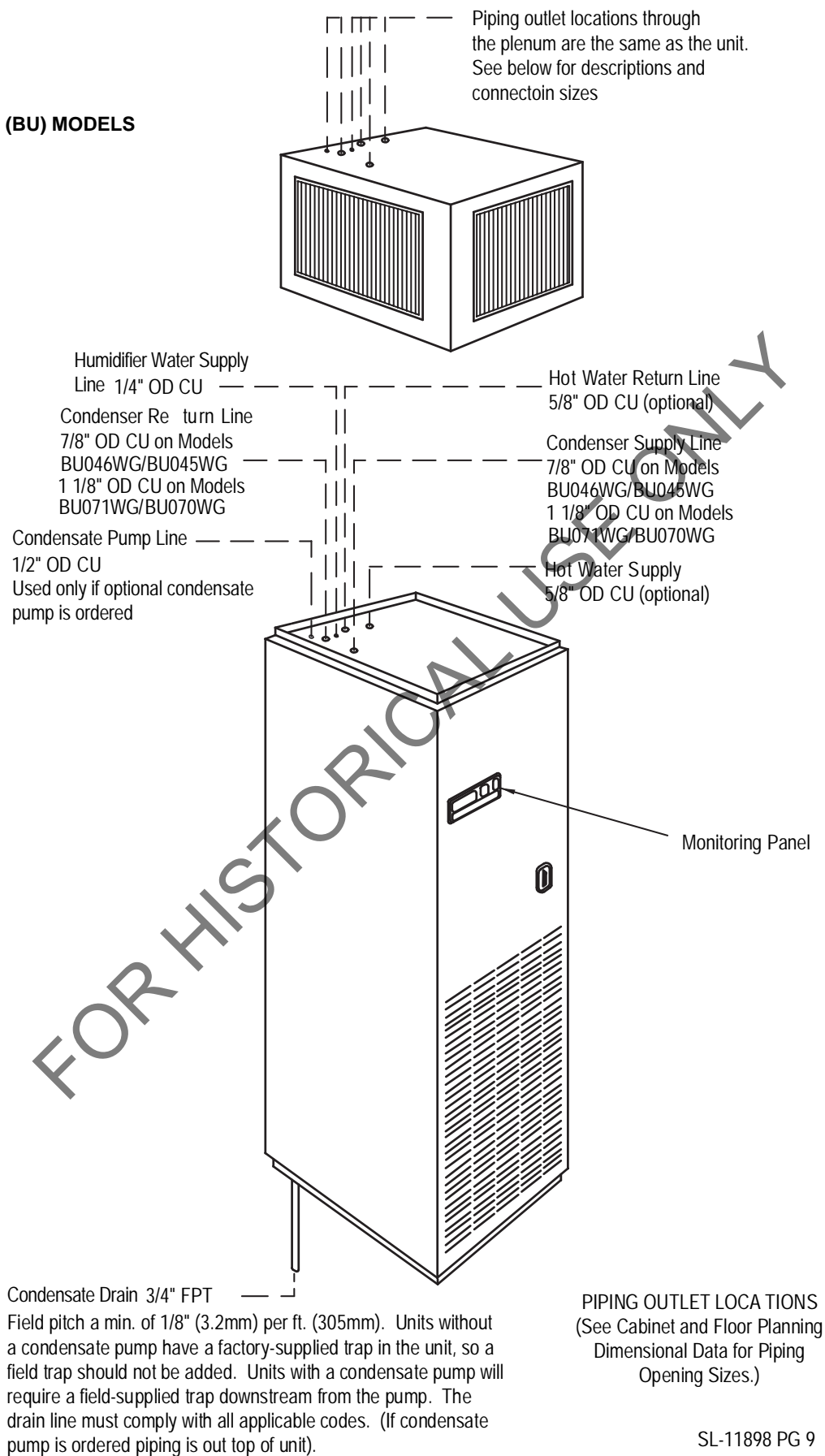

FOR HISTORICAL USE ONLY

2.6 Electrical Connections

Three-phase electrical service is required for all models in either 208, 230, 460, or 575 V, 60 Hz; or 200, 230, or 380/415 V, 50 Hz. Electrical service shall conform to national and local electrical codes. Refer to equipment nameplate regarding wire size and circuit protection requirements. Refer to electrical schematic when making connections.

A manual electrical disconnect switch should be installed within 5 feet (1.6 m) of the unit in accordance with codes, or a factory-supplied disconnect switch may be factory mounted within the unit accessible from the exterior.



WARNING

Use voltmeter to make sure power is turned off before making any electrical connections.



CAUTION

Three-phase power must be connected to the unit line voltage terminals in the proper sequence so that scroll the compressor rotates in the proper direction.

Figure 8 Electrical connections

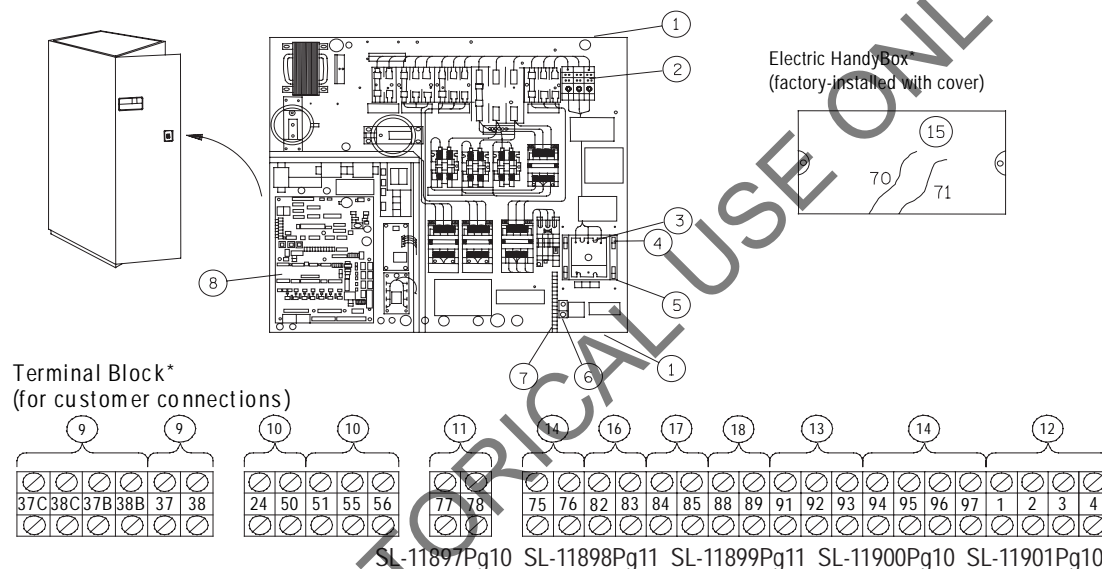

- Electric conduit knockouts** on top and bottom of electric box. Knockout size 1-3/4" (44.5 mm).
- Three phase connection.** Electric service connection terminals when factory disconnect is NOT supplied.
- Three phase connection.** Electric service connection terminals when factory disconnect switch is supplied.
- Factory installed disconnect switch.** (Optional).
- Three phase electric service** not by Liebert.
- Earth ground connection (50/60 Hz).** Connection terminal for field-supplied earth grounding wire.
- Earth ground bar (50 Hz only).** Connection terminals with factory ground from each high voltage component for field-supplied earth grounding wire.
- Control and monitoring section** of electric box.
- Remote unit shutdown.** Replace existing jumper between terminals 37 + 38 with normally closed switch having a minimum 75VA, 24VAC rating. Use field-supplied Class 1 wiring. Two additional contact pairs available as an option (labeled as 37B & 38B, 37C & 38C). Replace existing jumper for appropriate pair as done for 37 & 38.
- Special alarm connections.** Field-supplied 24V. Class 1 wiring for special alarm. Connection made by adding normally open contacts between terminals 24 + 50. Optional additional connections available with Advanced or Advanced with Graphics controls and appropriate optional accessories (connections 51, 55, and 56).
- SiteScan connection.** Terminals 77 (-) and 78 (+) are for connection of a 2 wire, twisted pair, communication cable (available from Liebert or others) to optional SiteScan.
- Remote condensing unit connection.** Field-supplied 24V Class 1 wiring to remote condensing unit terminals 1, 2, 3, & 4 from (R2) relay (split system only.)

13. **Smoke detector alarm connections.** Field-supplied 24V. Class 1 wiring to remote alarm circuits. Factory-wired contacts from optional smoke detector are #91 -comm., #92-NO, and #93-NC.
14. **Common alarm connection.** Field-supplied 24V. Class 1 wiring to common alarm terminals 75 + 76 (and optional 94 + 95, and 96 + 97), which are factory connected to common alarm relay (R3).
15. **Heat rejection connection.** Field-supplied 24V Class 1 wiring to interlock heat rejection from pigtailed 70 + 71 which are factory connected to compressor side switch (self-contained units only and to GLYCOOL relay (R5), GLYCOOL units only).
16. **Reheat and Humidifier Lockout.** Optional emergency power lockout of reheat and/or humidifier: connections provided for remote 24V AC source.
17. **Main Fan Auxiliary Switch.** Optional main fan auxiliary side switch. Terminals located in field wiring compartment for remote indication that the evaporator fan motor/unit is on. Field to connect 24V maximum.
18. **Optional Condensate Alarm (Dual Float Condensate Pump only).** Relay terminals located in field wiring compartment for remote indication.
*Located inside unit on top for Upflow and on base for Downflow.

2.7 Balancing the Air Distribution

2.7.1 Under-Floor Discharge Systems

The systems are designed for constant air delivery, therefore any unusual restrictions within the air circuit must be avoided. For under-floor air distribution, observe the following guidelines:

- Select the air supply grilles and perforated panels for the raised floor to ensure minimum loss of pressure in the circuit. Air volume dampers on grilles, which extend several inches below the surface of the raised floor, are usually detrimental to airflow.
- Consideration of the height of the damper on the grille in conjunction with the floor height will determine whether this type of grille may be used.
- The grilles used in raised floors vary in size, the largest being approximately 18" x 6" (457 x 152 mm). A larger grille size would be detrimental to the structural capacity of the raised floor panel. An 18" x 6" (457 x 152 mm) heavy duty, pencil-proof type grille typically has 56 square inches (0.036 m²) of free area.
- Perforated panels are available from various manufacturers of raised floors. These panels are usually 2' x 2' (610 x 610 mm) square and have a nominal free area of approximately 108 to 144 square inches (0.07 to 0.09 m²). Use caution in selecting perforated panels as some manufacturers have only 36 to 40 square inches (0.023 to 0.026 m²) of free area, requiring four times as many panels.
- Avoid floor elevations below 7-1/2" (190.5 mm), loosely installed flooring systems, and below-floor obstructions such as: electrical wiring chases, unusually long electronic system cables, or piping clusters.
- Always check specifications of the floor supplier before specifying the total number of perforated panels and grilles required to handle the air flow. The proper specifications for grilles and perforated panels should indicate the total free area required for air delivery rather than the number of panels and grilles. (See **Table 3** for recommended free area required for each model.) This table indicates the recommended free area based on having the supply air grilles and perforated panels sized to handle approximately 75% of the total cubic feet per minute (CFM) of the units at a velocity of 550 to 600 ft./min. (2.8 - 3.1 m/s). The remaining 25% of the air flow in the raised floor passes through cable cutouts, cracks between the panels, and other leakage areas.

Table 3 Recommended free area ft² (m²) for grilles or perforated panels at output velocities of 550 and 600 fpm (2.8 and 3.1 m/s)

50 Hz Units					60 Hz Units				
Model	550 FPM	2.8 m/s	600 FPM	3.1 m/s	Model	550 FPM	2.8 m/s	600 FPM	3.1 m/s
3 Ton	2.5	(0.01)	2.3	(0.01)	3 Ton	2.5	(0.01)	2.3	(0.01)
5 Ton	3.5	(0.02)	3.3	(0.02)	5 Ton	3.8	(0.02)	3.5	(0.02)

2.7.2 Ducted Applications

For ducted applications on units, the duct work may be attached to the top perimeter of the unit. Refer to **Figure 2** for information on upflow units and to **Figure 3** for downflow units.

The duct work on upflow units must allow access to the motors/blowers for maintenance. The duct work on upflow units must be designed within the capacity of the unit, otherwise air flow and performance will be compromised.

2.7.3 Plenum Installation

A solid plenum or plenum with discharge grille(s) may be installed. The plenum and instructions for its installation ship separately from the unit.

2.8 Checklist for Completed Installation

- 1. Unpack and check received material.
- 2. Proper clearance for service access has been maintained around the equipment.
- 3. Equipment is level and mounting fasteners are tight.
- 4. Piping completed to refrigerant or coolant loop (if required). Piping has been leak checked, evacuated and charged (if required).
- 5. Check piping within the unit & outside of the unit. Remove potential of rub-through or chaffing.
- 6. Condensate pump installed (if required).
- 7. Drain line connected.
- 8. Water supply line connected to humidifier (if required).
- 9. Field provided pan with drain installed under all ceiling mounted fluid condensing units (if installed).
- 10. Filter box installed (if applicable).
- 11. Ducting completed (if applicable).
- 12. Filter(s) installed.
- 13. Line voltage to power wiring matches equipment serial tag.
- 14. Power wiring connections completed between disconnect switch, evaporator and condensing unit, including earth ground.
- 15. Power line circuit breakers or fuses have proper ratings for equipment installed.
- 16. Control wiring connections completed to evaporator and condensing unit.
- 17. Verify water detection is properly installed around all units (if installed).
- 18. All wiring connections are tight.
- 19. Control panel DIP switches set based on customer requirements.
- 20. Foreign materials have been removed from, in and around all equipment installed (literature, shipping materials, construction materials, tools, etc.).
- 21. Fans and blowers rotate freely.
- 22. Inspect all piping connections for leaks during initial operations. Correct as needed.
- 23. Verify that a blank start-up sheet has been sent with the unit(s) and is ready to be completed by the installer.

FOR HISTORICAL USE ONLY

3.0 AIR COOLED MODELS

3.1 Condenser Location

The air cooled condenser should be located for maximum security and maintenance accessibility. Avoid ground level sites with public access or areas that contribute to heavy snow or ice accumulations. Utilize centrifugal condensers whenever interior building locations must be used. To assure adequate air supply, it is recommended that condensers be located in a clean air area, away from loose dirt and foreign matter that may clog the coil. In addition, condensers should not be located in the vicinity of steam, hot air, or fume exhausts. Also, condensers should be located no closer than three feet (1 meter) from a wall, obstruction, or adjacent unit.

Install condensers in a level position to assure proper refrigerant flow and oil return. For roof installation, mount condensers on steel supports in accordance with local codes. To minimize sound and vibration transmission, mount steel supports across load bearing walls. For ground installation, a concrete pad will provide adequate support. Condenser legs have mounting holes for securing the condenser to the steel supports or concrete pad.

3.2 Electrical Connections

Refer to equipment nameplate regarding wire size and circuit protection requirements. Refer to electrical schematic when making connections. Make all wiring and electrical connection in accordance with local and national codes.



WARNING

Use voltmeter to make sure power is turned off before making any electrical connections.

3.2.1 Line Voltage

Line voltage electrical service is required for all air cooled condensers at the location of the condenser. This power supply does not have to be the same voltage as the indoor unit. This separate power source may be 208, 230, 460, or 575 V, 60 Hz; or 200, 230, or 380/415 V, 50 Hz. The disconnect switch may be factory-supplied and mounted in the electrical panel or field-supplied and mounted per local and national codes.

3.2.2 Low Voltage

A control interlock between the condenser and the indoor unit is required and is connected between 70 and 71 in the handy box of the indoor unit and the electric panel of the air cooled condenser. NEC Class 1 wiring is required.

3.2.3 Lee-Temp/Flood Back Head Pressure Control Condensers

Lee-Temp condensers require a separate power supply for the heated receivers. This power supply is connected to the electrical connection box on the end of the receiver.

Figure 9 Air cooled condensers

FAN SPEED CONDENSER

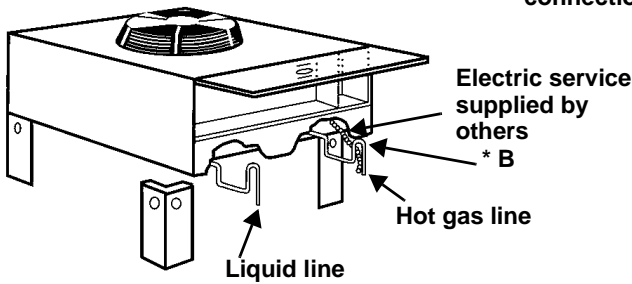

Secure each leg to condenser frame at all points shown using hardware provided.

Lee-Temp heater pad connection box

LEE-TEMP CONDENSER

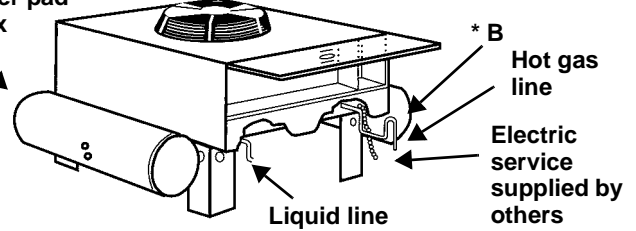

* B - Inverted traps are to be field-supplied and installed (typ). When installing traps, provide clearance for swing end of access door. Traps are to extend above base of coil by a minimum of 7-1/2" (190 mm)

SINGLE FAN AIR-COOLED CONDENSERS

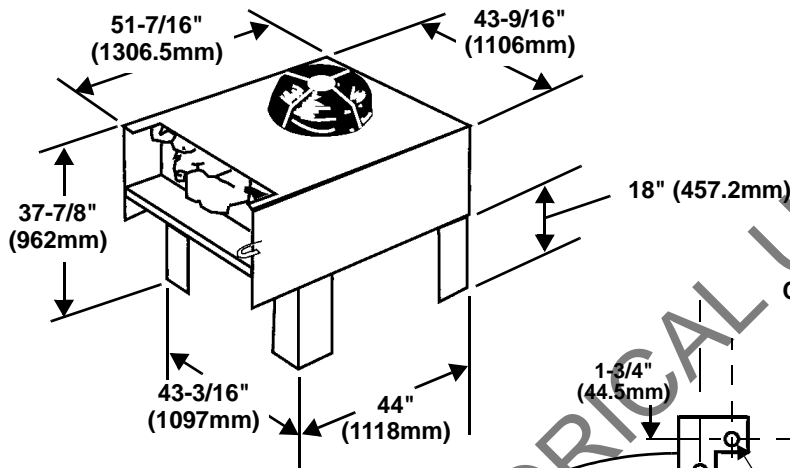

CONDENSER MOUNTING

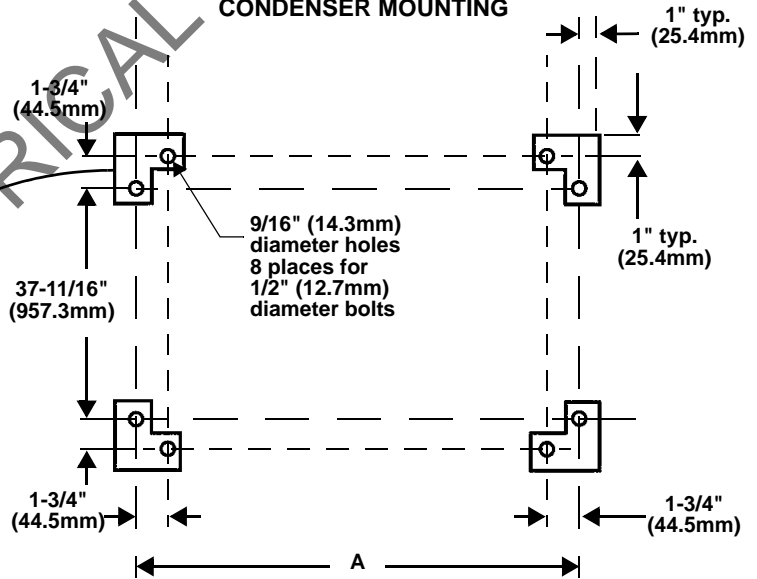

Common to all models. See Table 4 below for key to "A" dimension.

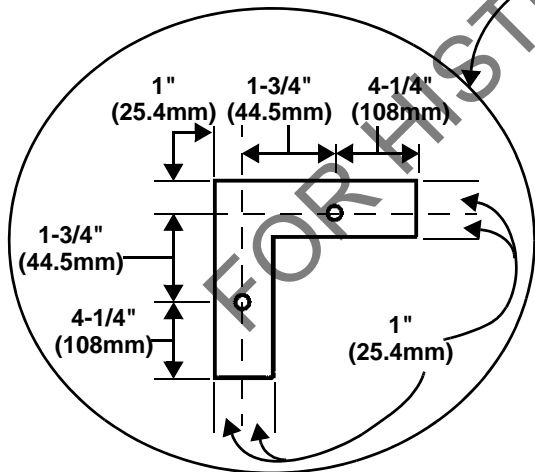

TYPICAL FOOTPRINT

Table 4 Air cooled condenser statistics

Model	Number of Fans	Connection Sizes (OD Copper)		Net Weight lbs (kg)	"A" Dimension in (mm)
		Hot Gas (in.)	Liquid (in.)		
083	1	7/8	5/8	295 (133.8)	42 (1067)
104	1	1-1/8	5/8	315 (142.8)	42 (1067)

3.3 Refrigerant Piping

All refrigeration piping should be installed with high temperature brazed joints. Prevailing good refrigeration practices should be employed for piping supports, leak testing, dehydration and charging of the refrigeration circuits.

Unit refrigeration components and piping are shipped from the factory with a nitrogen holding charge.



NOTE

The refrigeration piping should be isolated from the building by the use of vibration isolating supports.



NOTE

Piping, including inverted trap(s), must be routed to allow unobstructed access to the panel per the NEC.



NOTE

When installing field piping, care must be taken to protect all refrigerant lines from the atmosphere, especially when using refrigerants with POE oils. Do not allow the piping to stand open to air for more than 15 minutes. Units designed for R407C have a compressor that contains POE oil that is very hygroscopic; that is, it quickly absorbs water from the air. The longer the compressor piping is left open to air, the harder it will be to fully evacuate. If left open too long, the POE oil may need to be replaced before achieving the required vacuum level.



NOTE

Keep the evaporator unit and condenser closed with their factory charge of dry nitrogen while all field piping is installed. Keep the field piping clean and dry during installation, and do not allow it to stand open to the atmosphere. When all the field interconnecting piping is in place, vent the condenser dry nitrogen charge and connect to the field piping. Finally, vent the evaporator unit dry nitrogen charge and make its piping connections last.

Follow all proper brazing practices including a dry nitrogen purge to maintain system cleanliness.

Traps should be installed in the hot gas line on vertical risers at the base and every 25 feet (7.6 meters) in elevation. These traps will collect condensed refrigerant and refrigerant oil during the off cycle of the unit and ensure flow of refrigerant oil during operation.

A check valve is factory-supplied with the unit to be field-installed on the discharge side of the scroll compressor. Be sure to install the check valve with the refrigerant flow in the proper direction. When soldering or brazing the valve, it is very important to protect the internal parts by wrapping the valve with a damp cloth to keep the valve temperature below 250°F (121°C).

Approval is required whenever:

- a refrigerant piping run exceeds 150 ft (46 m) equivalent length
- an R22 system condenser must be located more than 15 ft (4.6 m) below the level of the cooling coil
- an R407C system condenser must be located below the level of the cooling coil.

Total discharge line pressure drop must not exceed 10 PSIG (69 kPa).

Consult your local Liebert representative when considering installations outside these guidelines.

Table 5 Recommended line sizes — OD copper (inches)*

Equivalent Length	3.5 Ton 042A (040A)		5 Ton 067A (065A)	
	Hot Gas Line	Liquid Line	Hot Gas Line	Liquid Line
50 ft. (15 m)	5/8	1/2	7/8	1/2
100 ft. (30 m)	3/4	1/2	7/8	5/8
150 ft. (45 m)	3/4	5/8	7/8	5/8

*Recommended vertical line sizes must be used for proper oil return at all cooling and dehumidification steps.

Table 6 Equivalent lengths (feet) for various pipe fittings

Copper Pipe O.D. in.	90 Degree Elbow Copper	90 Degree Elbow Cast	45 Degree Elbow	Tee	Gate Valve	Globe Valve	Angle Valve
1/2	0.8	1.3	0.4	2.5	0.26	7.0	4.0
5/8	0.9	1.4	0.5	2.5	0.28	9.5	5.0
3/4	1.0	1.5	0.6	2.5	0.3	12.0	6.5
7/8	1.45	1.8	0.8	3.6	0.36	17.2	9.5
1-1/8	1.85	2.2	1.0	4.6	0.48	22.5	12.0
1-3/8	2.4	2.9	1.3	6.4	0.65	32.0	16.0
1-5/8	2.9	3.5	1.6	7.2	0.72	36.0	19.5

Refrigerant trap = 4 times equivalent length of pipe per this table.

Table 7 Indoor unit refrigerant charge lbs (kg) R22 or R407C (per unit serial tag)

Model	R22	R407C
	Approximate Charge lbs (kg)	Approximate Charge lbs (kg)
42A/40A	1.0 (0.45)	0.9 (0.4)
67A/65A	1.5 (0.68)	1.4 (0.6)

Table 8 Line charges - refrigerant per 100 ft (30 m) of Type "L" copper tube

O.D.	R22		R407C	
	Liquid Line lbs (kg)	Hot Gas Line lbs (kg)	Liquid Line lbs (kg)	Hot Gas Line lbs (kg)
1/2"	7.3 (3.3)	1.3 (0.6)	6.9 (2.9)	-
5/8"	11.7 (5.3)	2.1 (1.0)	11.0 (4.6)	2.2 (0.9)
3/4"	16.6 (7.5)	3.0 (1.4)	15.7 (6.5)	3.1 (1.3)
7/8"	24.4 (11.1)	4.4 (2.0)	23.0 (9.6)	4.5 (1.9)

Table 9 Condenser refrigerant (per serial tag)

Model	R22		R407C	
	Approximate Charge lbs (kg)		Approximate Charge lbs (kg)	
	Fan Speed	Lee-Temp*	Fan Speed	Lee-Temp*
083	5 (2.27)	27 (12.3)	8 (3)	25 (12)
104	8 (3.63)	39 (17.7)	9 (4)	37 (17)

* Charge includes the receiver charge.

3.4 Fan Speed Control Systems

Fan Speed Control provides an infinite number of speed variations on specially designed, permanent split-capacitor motors. The control module varies the air quantity passing over the condenser coil by monitoring refrigerant pressure.

3.4.1 Materials Supplied

1. Built-in pre-wired condenser control box
2. Air cooled condenser
3. Piping access cover to be reinstalled when piping is complete
4. Bolts (four per leg) 3/8" x 5/8"
5. Terminal block for two-wire, 24-volt interlock connection between unit and condenser
6. Condenser legs, four on one-fan models

3.4.2 Dehydration/Leak Test and Charging Procedures for R22 (standard) or R407C (Optional)

Fan Speed Control Type Condenser



CAUTION

All local codes for handling refrigerant must be followed.



NOTE

As R22 and R407C are similar in properties, proper safety equipment and proper refrigeration tools are required on both types. Check unit nameplate for correct refrigerant type before topping off or recharging a system.



NOTE

Refrigerant R407C uses a POE (polyol ester) lubricant. The R407C refrigerant must be introduced and charged from the cylinder only as a liquid.



NOTE

When installing field piping, care must be taken to protect all refrigerant lines from the atmosphere, especially when using refrigerants with POE oils. Do not allow the piping to stand open to air for more than 15 minutes. Units designed for R407C have a compressor which contains POE oil that is very hygroscopic; that is, it quickly absorbs water from the air. The longer the compressor piping is left open to air, the harder it will be to fully evacuate. If left open too long, the POE oil may need to be replaced before achieving the required vacuum level.

Dehydration/Leak Test

1. Make sure unit is OFF. Open all disconnects and remove all fuses except control fuses. On units supplied with circuit breakers, open all breakers except for the transformer.
2. Add a jumper to the Fan Safety Switch between Common and Normal Open and disconnect the wire connected to the Normally Closed. Turn unit disconnect ON. (Fan operation not required.)



NOTE

The above allows the technician to use unit 24 VAC power and controls to open liquid line solenoid valve(s) and hot gas bypass solenoid valve(s) for the dehydration process. If no power is at the unit disconnect, the technician is to use a separate 24 VAC source rated at 75 VA and connect to the system liquid line solenoid valve(s) and hot gas bypass solenoid valve(s) directly.

3. Connect refrigeration gauges to the suction and discharge service valves of the compressor. Open all compressor service valves.
4. To energize the liquid line solenoid valves through the control system power, set the control temperature setpoint (see operation manual) to 60°F (15°C) and set the % relative humidity setpoint higher than the conditioned room ambient to ensure that solenoid valves and hot gas bypass valves are open during the dehydration process.
5. Pressurize the system circuit(s) to 150 PSIG (1034 kPa) by using dry nitrogen with a trace of refrigerant. Check system for leaks with suitable leak finder.
6. After completion of leak testing, release the test pressure (per local code) and pull a deep vacuum on the system with a suitable pump.
7. After four hours, check the pressure readings, and if they have not changed, break vacuum with refrigerant. Pull another vacuum to 250 microns or less. Recheck the pressure after two hours. After completing this step, pressurize the circuits with refrigerant (R407C liquid or R22 vapor per unit nameplate) until suction and discharge pressures have equalized.

Figure 10 Air cooled fan speed control general arrangement

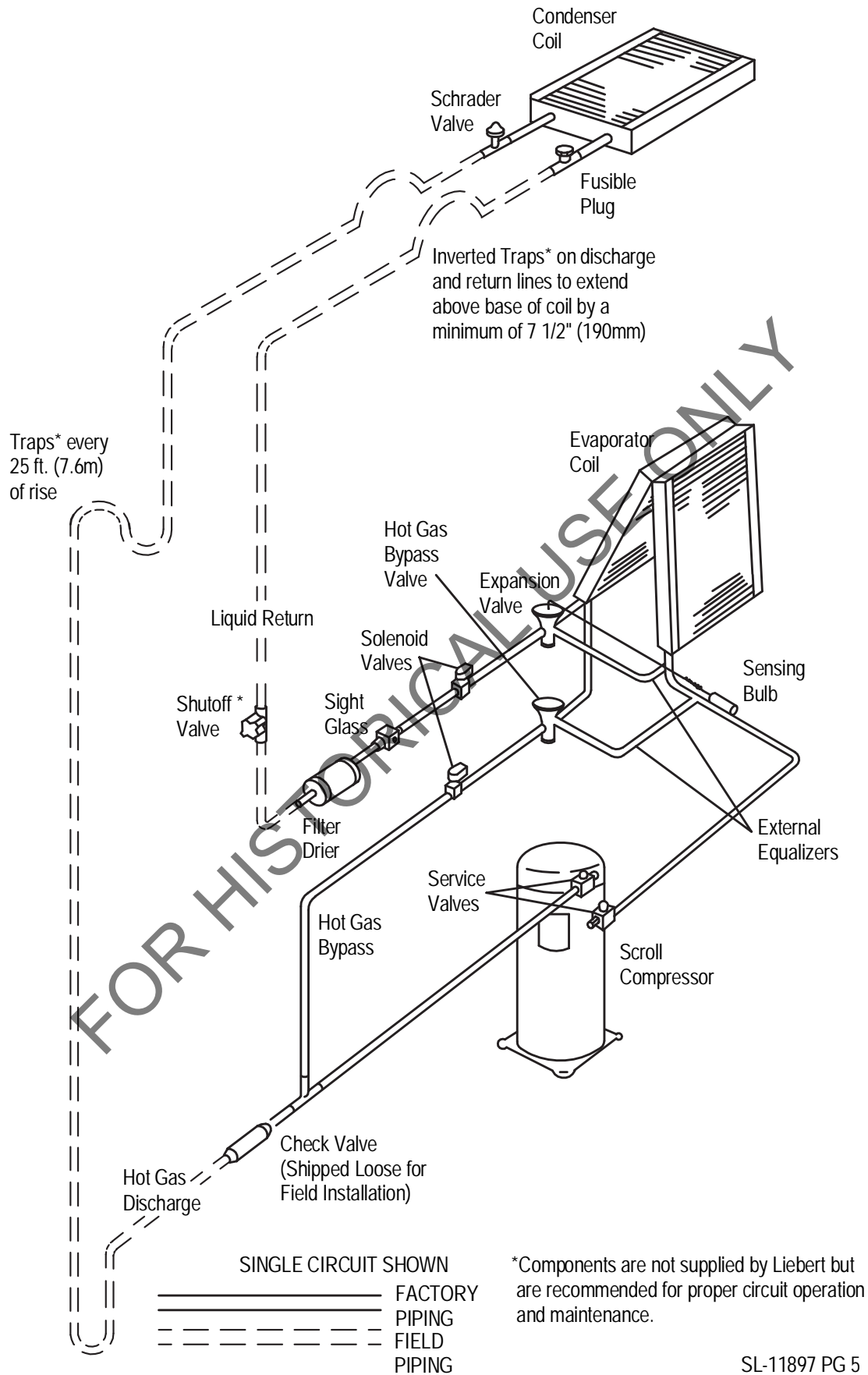

3.4.3 Charging

1. Make sure unit is OFF. Open all disconnect switches and, on units supplied with circuit breakers, open all breakers. Replace all fuses for the Fan and Compressors or close breakers.
2. Remove jumper on the Fan Safety Switch and reconnect the system wire connections. Ensure that all operational components are clear of debris. Turn unit ON. (Fan operation is required.) Check the evaporator fan for proper rotation and correct if necessary.
3. Connect the refrigerant gauge charging hose to the drum of refrigerant and to the suction and discharge service valves of the compressor.
4. Calculate the amount of charge for the system. Weigh in as much of the system charge as possible. Refer to the unit, condenser and refrigerant line charge tables.
5. Set the control temperature setpoint (see operation manual) to 60°F (15°C) and set the % relative humidity setpoint higher than the conditioned room ambient to ensure that solenoid valves and hot gas bypass valves are open during the charging procedure. You may have to bypass the LP Switch (low pressure switch) to start the compressors and stop short cycling. Reset the Head Pressure switch(es) if open.
6. Add refrigerant (R407C liquid, or R22 vapor per unit nameplate) to the suction side of the compressor until there is sufficient pressure to energize the low-pressure switch.



NOTE

When adding refrigerant to an operating system, it may be necessary to add the refrigerant through the compressor suction service valve. Because the refrigerant leaving the refrigerant cylinder must be in a liquid state, care must be exercised to avoid damage to the compressor. It is suggested that a sight glass be connected between the charging hose and the compressor suction service valve. This will permit adjustment of the cylinder hand valve so that liquid can leave the cylinder while allowing vapor to enter the compressor.

Then you may remove the manual bypass you applied earlier.

7. Charge the unit until the liquid line sight glass becomes clear. Then add one additional pound of refrigerant.
8. As head pressure builds, the condenser fan starts rotating. The fan becomes fully energized when sufficient head pressure is developed. (Fan starts to rotate at 190 psi and is full speed at 250 psi.)

Table 10 Refrigerant control settings psi (kPa)

Low Pressure Cut Out	Low Pressure Cut In	High Pressure Cut Out
20 (137.9)	65 (448.2)	360 (2482)

3.5 Lee-Temp/Flood Back Head Pressure Control Systems

The Lee-Temp system consists of a modulating type head pressure control valve and insulated receiver with heater pad to ensure operation at ambient temperatures as low as -30°F (-34.4°C).

3.5.1 Piping

Lee-Temp systems have two factory-supplied, field-installed check valves: one on the discharge side of the scroll compressor and one on the inlet side of the receiver. Be sure to install the check valves with the refrigerant flow in the proper direction. When soldering or brazing the valves, it is very important that the internal parts be protected by wrapping the valve with a damp cloth to keep the valve temperature below 250°F (121°C).

3.5.2 Materials Supplied

1. Built-in pre-wired condenser control box
2. Air cooled condenser
3. Piping access cover to be reinstalled when piping is complete
4. Bolts (four per leg) 3/8" x 5/8"
5. Terminal block for two-wire 24V interlock connection between the unit and the condenser
6. Condenser legs: four on one-fan models
7. Lee-Temp system:
 - a. Insulated storage receiver
 - b. Head pressure control valve with integral check valve
 - c. Adapter assembly
 - d. Rotalock valve
 - e. Pressure relief valve
 - f. Liquid level sight glass
 - g. Check valve
8. Bolts - (six per receiver) 3/8" x 1"



NOTE

Lee-Temp heater pad requires a separate, continuous electrical source of either 115 VAC or 200/208/230 VAC.

3.5.3 Dehydration/Leak Test and Charging Procedures for R22 (Standard) or R407C (Optional)

Lee-Temp Control Type Condenser



CAUTION

All local codes for handling refrigerant must be followed.



NOTE

As R22 and R407C are similar in properties, proper safety equipment and proper refrigeration tools are required on both types. Check unit nameplate for correct refrigerant type before topping off or recharging a system.



NOTE

Refrigerant R407C uses a POE (polyol ester) lubricant. The R407C refrigerant must be introduced and charged from the cylinder only as a liquid.



NOTE

When installing field piping, care must be taken to protect all refrigerant lines from the atmosphere, especially when using refrigerants with POE oils. Do not allow the piping to stand open to air for more than 15 minutes. Units designed for R407C have a compressor which contains POE oil that is very hygroscopic; that is, it quickly absorbs water from the air. The longer the compressor piping is left open to air, the harder it will be to fully evacuate. If left open too long, the POE oil may need to be replaced before achieving the required vacuum level.

Dehydration/Leak Test

1. Make sure unit is OFF. Open all disconnect switches and pull all fuses except control fuses. On units supplied with circuit breakers, open all breakers except for the transformer.
2. Add a jumper to the Fan Safety Switch between Common and Normal Open and disconnect the wire connected to the Normally Closed. Turn unit disconnect ON. (Fan operation not required.)



NOTE

The above allows the technician to use unit 24 VAC power and controls to open liquid line solenoid valve(s) and hot gas bypass solenoid valve(s) for the dehydration process. If no power is at the unit disconnect, the technician is to use a separate 24 VAC source rated at 75 VA and connect to the system liquid line solenoid valve(s) and hot gas bypass solenoid valve(s) directly.

3. Connect refrigeration gauges to the suction and discharge service valves of the compressor and open.
4. Attach a “jumper” hose from the Rotalock fitting on the outlet of the receiver and the Schrader fitting on the liquid header of the condenser. Front seat the Rotalock valve approximately two turns.
5. To energize the liquid line solenoid valve(s) through the control system, set the temperature setpoint (see operation manual) to 60°F (15°C) and set the % relative humidity setpoint higher than the conditioned room ambient to ensure that solenoid valves and hot gas bypass valves are open during the dehydration process.
6. Pressurize system circuit(s) to 150 PSIG (1034 kPa) by using dry nitrogen with a trace of refrigerant. Check system for leaks with suitable leak finder.
7. After completion of leak testing, release test pressure (per local code) and pull a vacuum on the system.
8. After 4 hours, check pressure readings and, if they have not changed, break vacuum with refrigerant. Pull a second and third vacuum of 250 microns or less. Recheck pressure after 2 hours.

3.5.4 Charging

1. Make sure unit is OFF. Open all disconnect switches and, on units supplied with circuit breakers, open all breakers. Replace all fuses for the Fan and Compressors or close breakers.
2. Remove jumper on the Fan Safety Switch and reconnect the system wire connections. Ensure that all operational components are clear of debris. Turn unit ON. (Fan operation is required.) Check the evaporator fan for proper rotation and correct if necessary.
3. Connect the refrigerant gauge charging hose to the drum of refrigerant and to the suction and discharge service valves of the compressor(s).
4. Calculate the amount of charge for the system. Weigh in as much of the system charge as possible. Refer to the unit, condenser and refrigerant line charge tables.
5. Set the control temperature setpoint (see operation manual) to 60°F (15°C) and set the % relative humidity setpoint higher than the conditioned room ambient to ensure that solenoid valves and hot gas bypass valves are open during the charging procedure. You may have to bypass the LP Switch (low pressure switch) to start the compressors and stop short cycling. Reset the Head Pressure switch(es) if open.
6. Add refrigerant (R407C liquid or R22 vapor per unit nameplate) to the suction side of the compressor until there is sufficient pressure to energize the low pressure switch.



NOTE

When adding refrigerant to an operating system, it may be necessary to add the refrigerant through the compressor suction service valve. Because the refrigerant leaving the refrigerant cylinder must be in a liquid state, care must be exercised to avoid damage to the compressor. It is suggested that a sight glass be connected between the charging hose and the compressor suction service valve. This will permit adjustment of the cylinder hand valve so that liquid can leave the cylinder while allowing vapor to enter the compressor.

Then you may remove the manual bypass you applied earlier.

7. Charge the unit until the proper charge is weighed in.

Table 11 Refrigerant control settings psi (kPa)

Low Pressure Cut Out	Low Pressure Cut In	High Pressure Cut Out
20 (137.9)	65 (448.2)	360 (2482)

Figure 11 Air cooled, Lee-Temp general arrangement

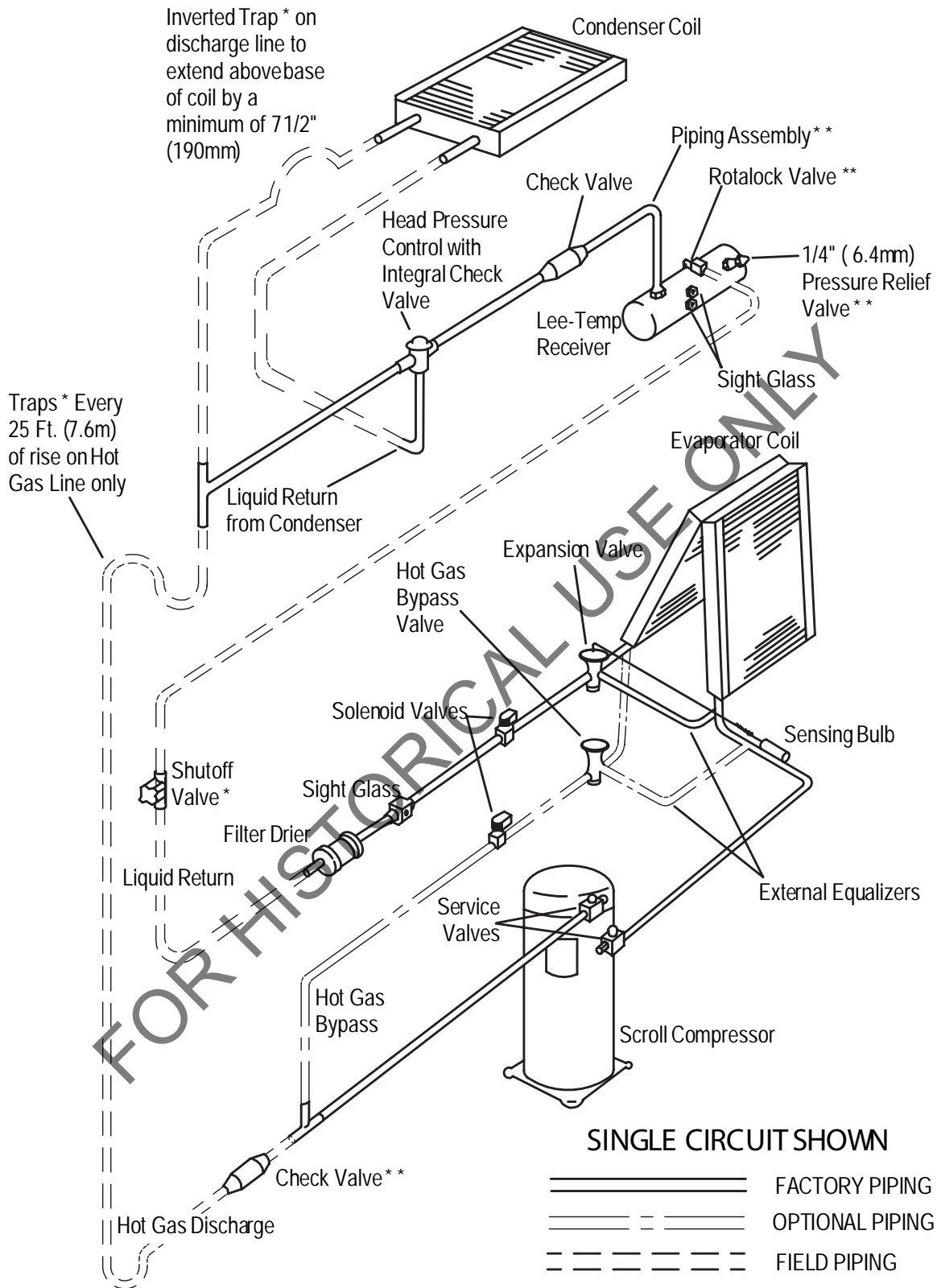

Traps* Every 25 Ft. (7.6m) of rise on Hot Gas Line only

Inverted Trap* on discharge line to extend above base of coil by a minimum of 7 1/2" (190mm)

Condenser Coil

Piping Assembly**

Check Valve

Rotalock Valve**

Head Pressure Control with Integral Check Valve

Lee-Temp Receiver

1/4" (6.4mm) Pressure Relief Valve**

Sight Glass

Evaporator Coil

Liquid Return from Condenser

Expansion Valve

Hot Gas Bypass Valve

Solenoid Valves

Sensing Bulb

Shutoff Valve*

Sight Glass

Filter Drier

Liquid Return

Service Valves

External Equalizers

Hot Gas Bypass

Scroll Compressor

Check Valve**

Hot Gas Discharge

SINGLE CIRCUIT SHOWN

- ===== FACTORY PIPING
- OPTIONAL PIPING
- .-.-.-.- FIELD PIPING

* Components are not supplied by Liebert but are recommended for proper circuit operation and maintenance.
 ** Components supplied by Liebert and must be field installed.

4.0 WATER COOLED MODELS

4.1 Piping Considerations

Manual shut-off valves should be installed at the supply and return lines of each unit. This will provide for routine maintenance or emergency isolation of the unit.

When the water source for the condenser is of poor quality, it is good practice to provide cleanable filters in the supply line. These filters will trap the particles in the water supply and extend the service life of the water cooled condenser.

To provide for the emergency of water leaks and the consequences of sub-floor flooding, floor drains should be provided with wet traps or a water detection system such as a Liqui-tect sensor that is installed near the base of the unit or below the elevated floor.

4.2 Condenser

The condenser is designed to operate in conjunction with either a cooling tower or city water. The maximum water pressure is 150 psig (1034 kPa). A high pressure system rated at 350 psig (2413 kPa) is available as an option.

FOR HISTORICAL USE ONLY

Figure 12 Water cooled general arrangement

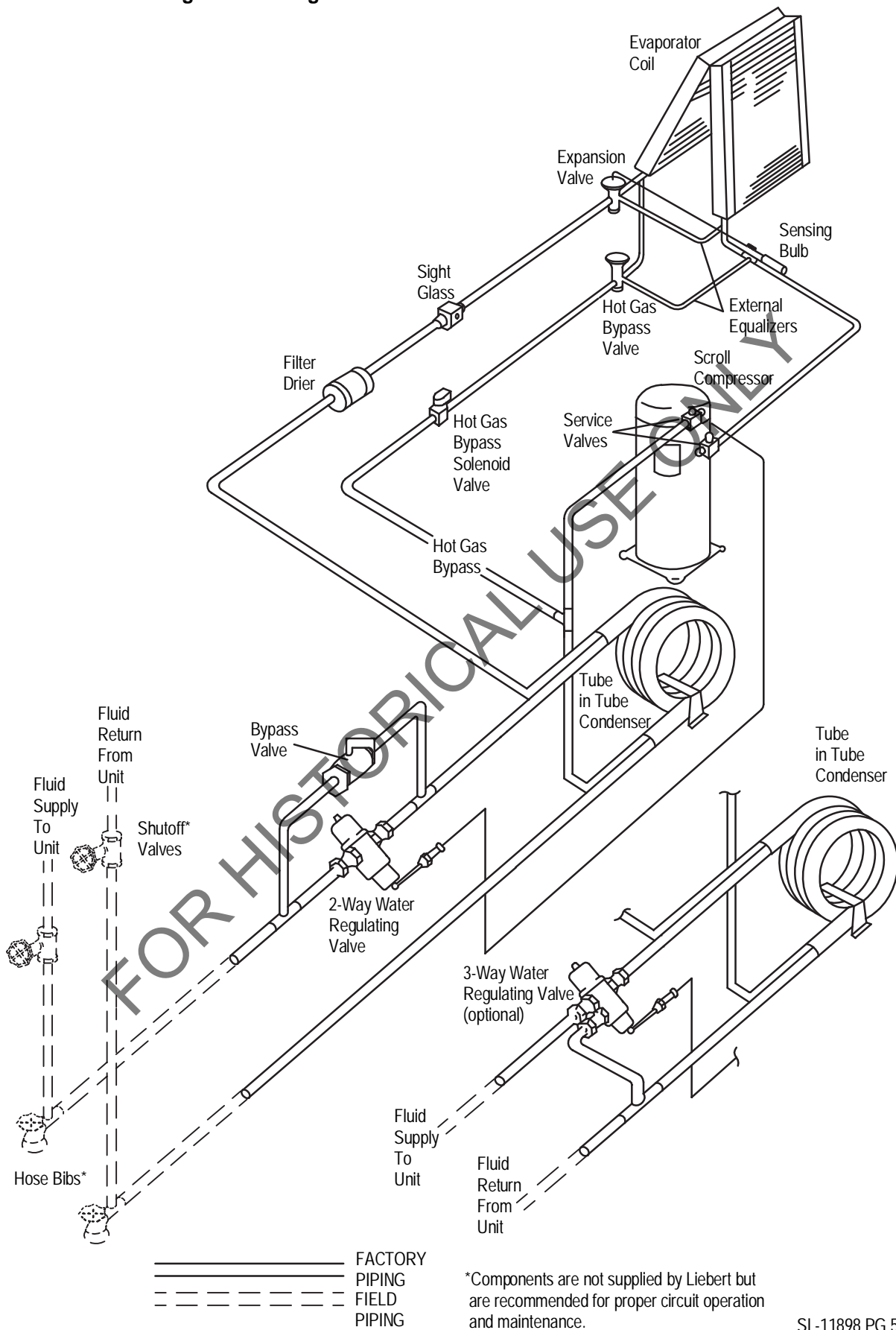

4.3 Water Regulating Valve

The water regulating valve automatically regulates the amount of fluid necessary to remove the heat from the refrigeration system, permitting more fluid to flow when load conditions are high and less fluid to flow when load conditions are low. The valve consists of a brass body, balance spring, valve seat, valve disc holders, capillary tube to discharge pressure, and adjusting screw.

4.3.1 Standard Valve - 150psig (1034kPa) System for 3 & 5 Ton Units (Johnson Controls Valve) High Pressure Valve - 350psig (2413kPa) System for 5 Ton Units (Johnson Controls Valve)

Adjustment

The valve may be adjusted with a standard refrigeration service valve wrench or screw driver.

To lower the head pressure setting, turn the square adjusting screw clockwise until the high pressure gauge indicates the desired setting.

To raise the head pressure setting, turn the adjusting screw counterclockwise until the desired setting is obtained.

Figure 13 Johnson Controls valve adjustment

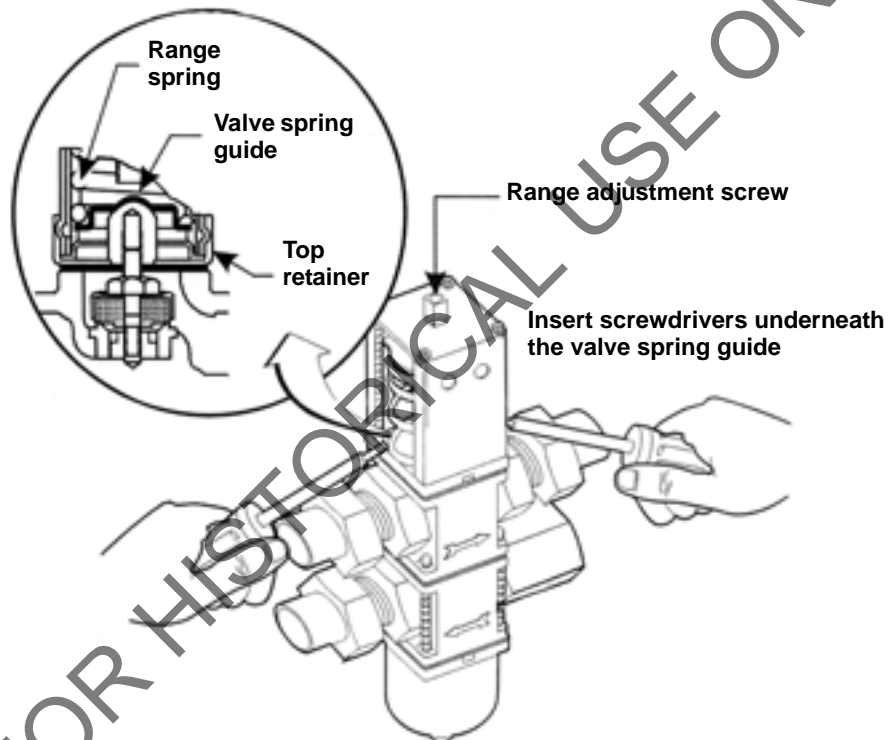

Manual Flushing

The valve may be flushed by inserting a screwdriver or similar tool under the two sides of the main spring and lifting. This action will open the valve seat and flush any dirt particles from the seat. If this fails, it will be necessary to disassemble the valve and clean the seat.

4.3.2 High Pressure Valve - 350 psig (2413 kPa) System for 3 Ton Units (Metrex Valve)

Adjustment

The valve may be adjusted using a 1/8" diameter rod. Turn the adjusting collar nut counterclockwise to raise head pressure; turn it clockwise to lower head pressure. Rotation directions are viewed from top of valve spring housing.

Figure 14 Metrex Valve adjustment



Table 12 Refrigerant control settings psi (kPa)

Low Pressure Cut Out	Low Pressure Cut In	High Pressure Cut Out
20 (137.9)	65 (448.2)	360 (2482)

Manual Flushing

The valve may be flushed by rotating the socket head screw clockwise. This screw must be in the OUT position (counterclockwise) for normal valve operation.

4.3.3 Testing Valve Function

When the refrigeration system has been off for approximately 10-15 minutes, the water flow should stop.

Should the water continue to flow, the valve is either improperly adjusted or the pressure sensing capillary is not properly connected to the condenser.

5.0 GLYCOL/GLYCOOL COOLED MODELS

5.1 Drycooler Location

The drycooler should be located for maximum security and maintenance accessibility. Avoid ground-level sites with public access or areas which contribute to heavy snow or ice accumulations. To assure adequate air supply, it is recommended that drycoolers be located in a clean air area, away from loose dirt and foreign matter that may clog the coil. In addition, drycoolers should not be located in the vicinity of steam, hot air or fume exhausts. Also, drycoolers should not be located closer than 3 feet (1 meter) from a wall, obstruction or adjacent unit.

5.2 Drycooler Installation

For roof installation, mount drycoolers on steel supports in accordance with local codes. To minimize sound and vibration transmission, mount steel supports across load bearing walls. For ground installation, a concrete pad will provide adequate support. Drycooler legs have mounting holes for securing the drycooler to steel supports or concrete pad.

5.3 Electrical Connections

Refer to equipment nameplate regarding wire size and circuit protection requirements. Refer to electrical schematic when making connections. Make all wiring and electrical connections in accordance with local and national codes.



WARNING

Use voltmeter to make sure power is turned off before making any electrical connections.

5.3.1 Line Voltage

Line voltage electrical service is required for all drycoolers at the location of the drycooler. This power supply does not have to be the same voltage as the indoor unit. This separate power source may be 208, 230, 460, or 575 V, 60 Hz; or 200, 230, or 380/415 V, 50 Hz. The disconnect switch is factory-supplied and mounted in the electric panel.

5.3.2 Low Voltage

A control interlock between the drycooler and the indoor unit is required and is connected between 70 and 71 in the handy box of the indoor unit and the pump and drycooler control box of the drycooler. NEC Class 1 wiring is required.

5.3.3 Pump and Drycooler

All wiring to the pump and drycooler from the control box should be done in accordance with the electrical schematic on the inside lid of the drycooler control box and with local and national codes.

5.4 Glycol Piping



CAUTION

Galvanized pipe must not be used in or with systems or units that contain glycol. The phosphates in the inhibitor can react with the zinc in the galvanized pipe, precipitating an insoluble material that can eventually foul the system.



CAUTION

To help prevent piping failures, supply and return lines must be supported in a way that keeps their weight from bearing on the piping of the unit, drycooler or pumps.



CAUTION

To avoid the possibility of burst pipes, it is necessary to install a relief valve in the system. This valve may be obtained from the supplier as an option or obtained from another vendor.



CAUTION

Fluid cooled condensers have small internal flow passages. To avoid clogging and other resulting system operation problems, install a 16-20 mesh filter in the fluid supply line to the indoor unit. The filter should be located where it can be easily serviced or replaced.



CAUTION

Do not install unit on open loop systems. Debris carried by the fluid will clog the brazed plate condenser.

It is recommended that manual service shut-off valves be installed at the supply and return connections to each unit. This enables routine service and/or emergency isolation of the unit. In addition, multiple pump packages require a check valve at the discharge of each pump to prevent back flow through the standby pump(s).

To facilitate filling, installation of hose bibs at the lowest point of the system is recommended.

Consideration of the minimum glycol temperature to be supplied from the drycooler will determine if the need exists to insulate the glycol supply and return lines. Insulation will prevent condensation on the glycol lines in low ambient conditions.

All fluid piping must comply with local codes. Care in sizing pipes will help reduce pumping power and operating costs.

Table 13 Room dew point temperatures

Dry Bulb °F (°C)	Wet Bulb °F (°C)	Relative Humidity	Dew Point* °F (°C)
70 (21.1)	57.2 (14.0)	45	48.0 (8.9)
70 (21.1)	58.5 (14.7)	50	50.5 (10.3)
72 (22.2)	58.9 (24.9)	45	50.0 (10.0)
72 (22.2)	60.0 (15.5)	50	52.4 (11.3)
75 (23.8)	61.2 (16.2)	45	52.4 (11.3)
75 (23.8)	62.5 (16.9)	50	55.0 (12.7)

* Minimum glycol temperature before condensation will occur.

5.4.1 Expansion Tanks, Fluid Relief Valves and Other Devices

An expansion tank must be provided for expansion and contraction of the fluid due to temperature change in this closed system. Vents are required at system high points to vent trapped air when filling the system. A relief valve is also a necessary piping component.

Depending on the complexity of the system, various other devices may be specified. Pressure gauges, flow switches, automatic air separator, tempering valves, standby pumps, sensors for electrical controls, and flow switches are just a few of these devices.



CAUTION

Immediately following the use of water for leak testing or system cleaning, charge the tested system with the proper percentage of glycol and water for your coldest design ambient. Complete system drain-down cannot be assured and damage to the system could result from freezing of residual water.

5.5 Filling Instructions

5.5.1 Preparing the System for Filling

It is important to remove any dirt, oil or metal filings that may contaminate the cooling system piping in order to prevent contamination of the fresh glycol solution and fouling of the drycooler piping. The system should be flushed thoroughly using a mild cleaning solution or high-quality water and then completely drained before charging with glycol. Cleaning new systems is just as important as cleaning old ones. New systems can be coated with oil or a protective film; dirt and scale are also common. Any residual contaminants could adversely affect the heat transfer stability and performance of your system. In many cases, in both old and new systems, special cleaners are needed to remove scale, rust and hydrocarbon foulants from pipes, manifolds and passages. Clean heat transfer surfaces are important in maintaining the integrity of the heating/cooling system. For more information on cleaners and degreasers, contact your sales representative. Follow the manufacturer's instructions when using these products.

Calculate the internal volume of the system as closely as possible. See **Table 14** and **Table 16** for unit volumes. Use volume in **Table 15** for glycol piping volumes.

Table 14 Indoor unit glycol volume approximate gallons (liters) max.

Model (50 Hz)	Glycol Cooled	GLYCOOL
046WG/(045WG)	1.2 (4.5)	
071WG/(070WG)	2.0 (7.5)	
061G/(058G)		4.0 (15.1)

Table 15 Volume in standard Type "L" copper piping

Diameter (in.)		Volume	
Outside	Inside	Gal/Ft	L/M
1/2	0.123	0.008	0.01
5/8	0.555	0.012	0.15
3/4	0.666	0.018	0.22
7/8	0.785	0.025	0.31
1-1/8	1.025	0.043	0.53

5.5.2 Glycol Solutions



NOTE

Glycol solutions should be considered for protection of the coil. When it is not used, damage can occur from either freezing or corrosion from water.

When considering the use of any glycol products in a particular application, you should review the latest Material Safety Data Sheets and ensure that the use you intend can be accomplished safely. For Material Safety Data Sheets and other product safety information, contact the supplier nearest you. Before handling any other products mentioned in the text, you should obtain available product safety information and take necessary steps to ensure safety of use.



CAUTION

When mishandled, glycol products pose a threat to the environment. Before using any glycol products, review the latest Material Safety Data Sheets and ensure that you can use the product safely.

Glycol manufacturers request that the customer read, understand and comply with the information on the product packaging and in the current Material Safety Data Sheets. Make this information available to anyone responsible for operation, maintenance and repair of the drycooler and related equipment.

No chemical should be used as or in a food, drug, medical device, or cosmetic, or in a product or process in which it may contact a food, drug, medical device, or cosmetic until the user has determined the suitability and legality of the use. Since government regulations and use conditions are subject to change, it is the user's responsibility to determine that this information is appropriate and suitable under current, applicable laws and regulations.



CAUTION

Automotive antifreeze is unacceptable and must NOT be used.

Typical inhibited formula ethylene glycol and propylene glycol manufacturers and suppliers are Union Carbide (Ucartherm) or Dow Chemical (Dowtherm SR-1, Dowfrost). These glycols are supplied with corrosion inhibitors and do not contain a silicone anti-leak formula. Commercial ethylene glycol, when pure, is generally less corrosive to the common metals of construction than water itself. Aqueous solutions of these glycols, however, assume the corrosivity of the water from which they are prepared and may become increasingly corrosive with use if not properly inhibited.

There are two basic types of additives: corrosion inhibitors and environmental stabilizers. The corrosion inhibitors function by forming a surface barrier that protects the metals from attack. Environmental stabilizers, while not corrosion inhibitors in the strictest sense of the word, decrease corrosion by stabilizing or favorably altering the overall environment. An alkaline buffer such as borax is a simple example of an environmental stabilizer since its prime purpose is to maintain an alkaline condition (pH above 7).

The percentage of glycol to water must be determined by using the lowest design outdoor temperature in which the system is operating. **Table 16** indicates the solution freeze point at several concentration levels of ethylene glycol. Propylene glycol concentrations should be 1% higher than the ethylene glycol table values to find the freeze point. For example, 41% propylene glycol freezes at -10°F.

Table 16 Ethylene glycol concentrations

% Glycol by Volume	0 *	10	20	30	40	50
Freezing Point °F (°C)	32 (0)	25 (-3.9)	16 (-8.9)	5 (-15.0)	-10 (-23.3)	-32 (-35.5)
Apparent Specific Gravity @ 50°F (10°C)	1	1.014	1.028	1.042	1.057	1.071

* A minimal amount of glycol should be considered for inhibitive coil protection.



CAUTION

The quality of water used for dilution must be considered because water may contain corrosive elements which reduce the effectiveness of the inhibited formulation. Water that is classified as soft (low in chloride and sulfate ion content less than 100 parts per million each) should be used.

5.5.3 Filling the System

Installation of hose bibs at the lowest point of the system is recommended. When filling a glycol system keep air to a minimum. Air in glycol turns to foam and is difficult and time-consuming to remove. (Anti-foam additives are available and may be considered.) Open all operating systems to the loop. With the top vent(s) open, fill the system from the bottom of the loop. This will allow the glycol to push the air out of the top of the system, minimizing trapped air. Fill to approximately 80% of calculated capacity. Fill slowly from this point, checking fluid levels until full.

**NOTE**

For glycol solution preparation and periodic testing, follow manufacturer's recommendations. Do not mix products of different manufacturers.

FOR HISTORICAL USE ONLY

Figure 15 Drycoolers and pump packages

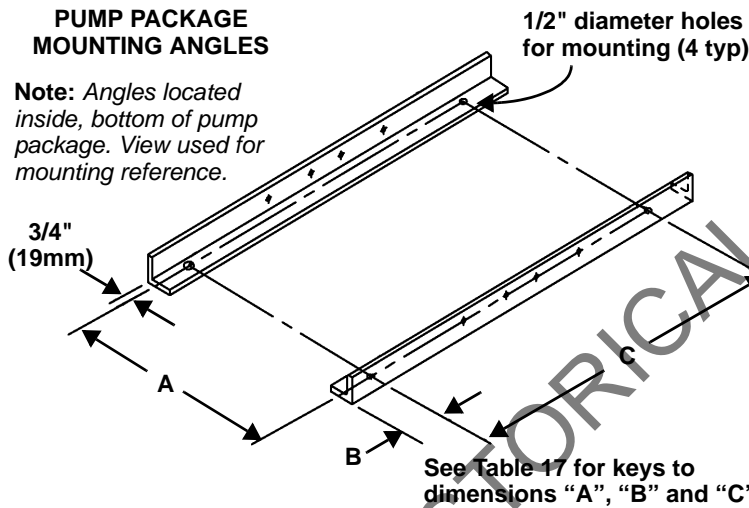
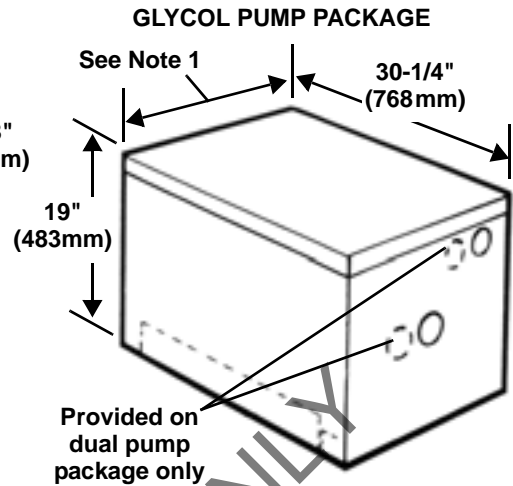
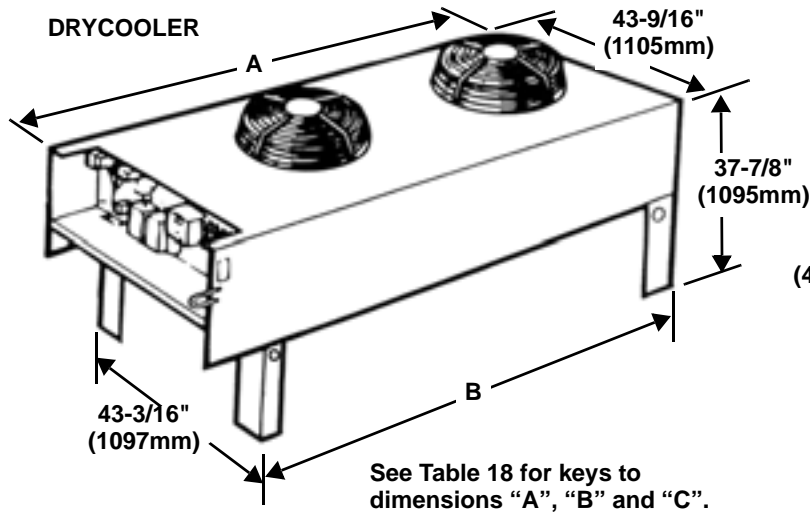

Notes

1. Single pump packages are 17-1/4" (438 mm) wide. Dual pump packages are 32-1/4" (819 mm) wide.
2. Mounting holes are 15-1/4" (387 mm) apart on single pump packages and 30-1/4" (768 mm) apart on dual pump packages.
3. Connection sizes apply to primary pump supplier.

For expansion tank dimensions, see Figure 16 on page -36.

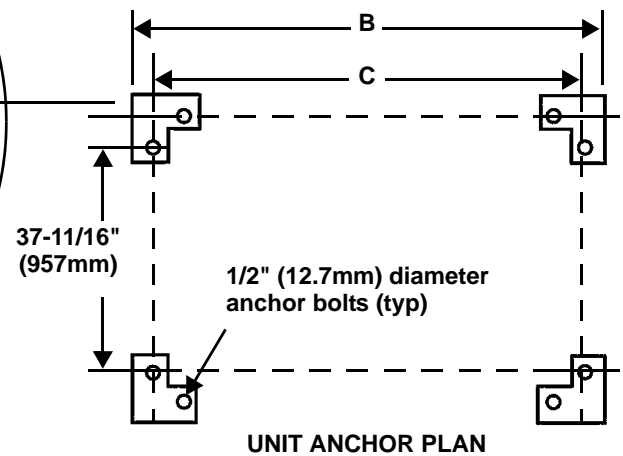
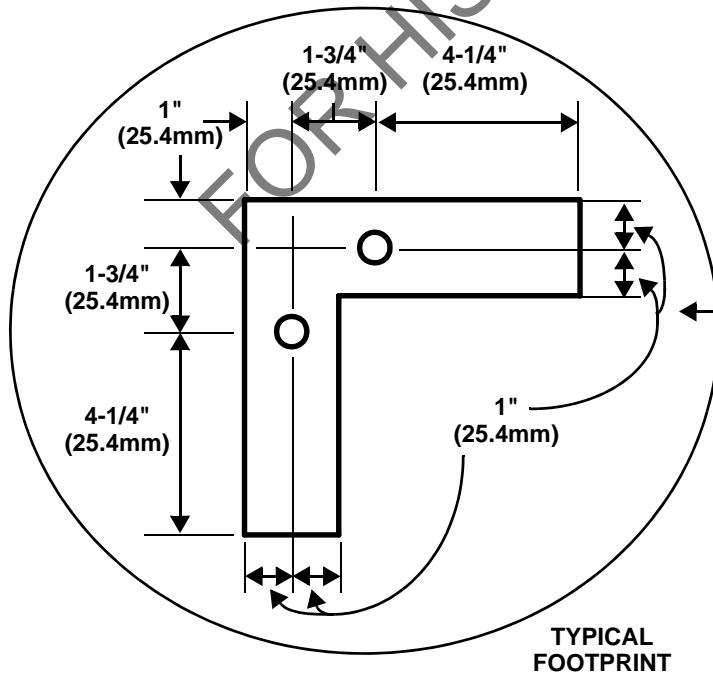

Figure 16 Pump packages—expansion tank

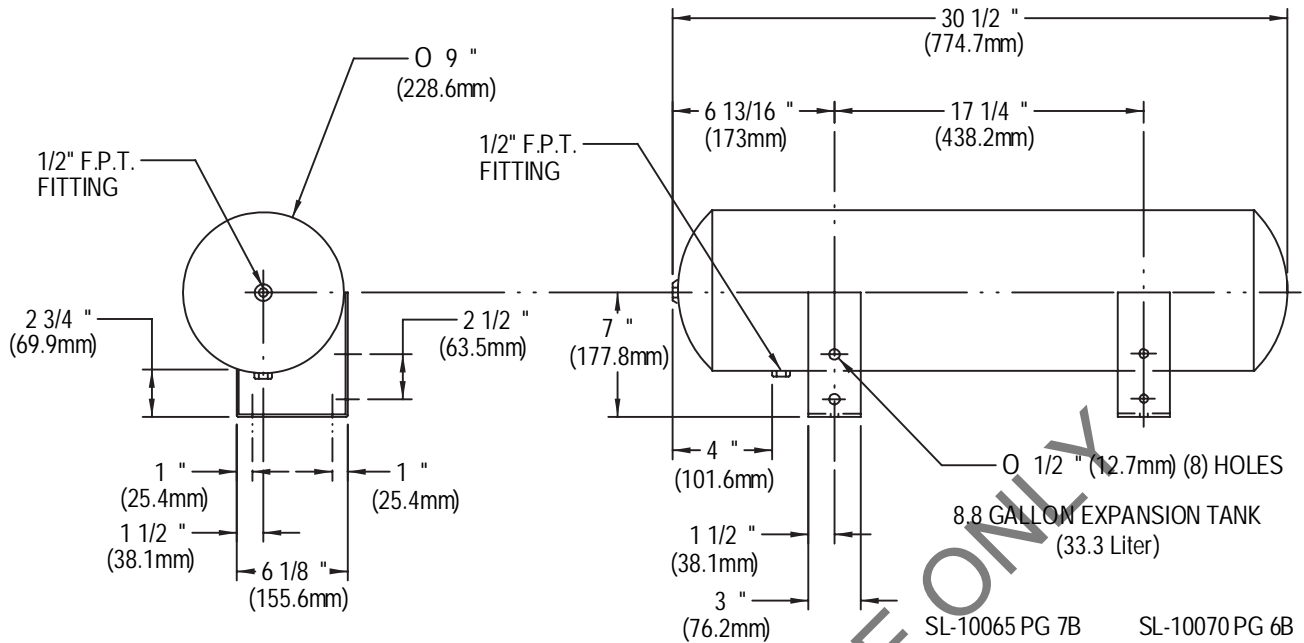

Table 17 Mounting hole dimensional data

PUMP PACKAGE	A in (mm)	B in (mm)	C in (mm)
SINGLE (0.75 - 7.5 Hp)	15-1/4 (387.4)	2-1/2 (63.5)	22-1/2 (571.5)
DUAL (0.75 - 5 Hp)	30-1/4 (768.4)	2-1/2 (63.5)	22-1/2 (571.5)
DUAL (7.5 Hp)	39-5/16 (998.5)	1-3/4 (44.5)	26-7/8 (682.6)

Table 18 Drycooler data

Model No.	No. of Fans	Weight lbs (kg)	Drycooler Conn. Sizes (Suct. & Disc.) in.	"A" Dimension in. (mm)	"B" Dimension in. (mm)	"C" Dimension in. (mm)	Coil Internal Volume gal. (l)
-069	1	410 (186)	1-1/4	51-1/2 (1308)	44 (1118)	42 (1067)	2.4 (9.2)
-092	1	430 (195)	1-1/2	51-1/2 (1308)	44 (1118)	42 (1067)	3.7 (13.9)
-109	1	450 (204)	2	51-1/2 (1308)	44 (1118)	42 (1067)	4.9 (18.6)
-112	1	470 (213)	2	51-1/2 (1308)	44 (1118)	42 (1067)	5.8 (22.0)
-139	2	565 (256)	2	91-1/2 (2324)	84 (2134)	82 (2083)	4.8 (18.2)
-197	2	605 (274)	2	91-1/2 (2324)	84 (2134)	82 (2083)	9.0 (34.1)

Table 19 Glycol pump data*

Pump		Pump Suction Connection in.	Pump Discharge Connection in.
Hp	Hz		
1-1/2	60	1-1/4	3/4
2	60	1-1/4	3/4
3	60	1-1/2	1
5	60	1-1/2	1-1/4
1	50	1-1/4	3/4
1-1/2	50	1-1/4	3/4
2	50	1-1/4	3/4
3	50	1-1/2	1-1/4

* Connection sizes apply to primary pump supplier

Figure 17 Glycol general arrangement

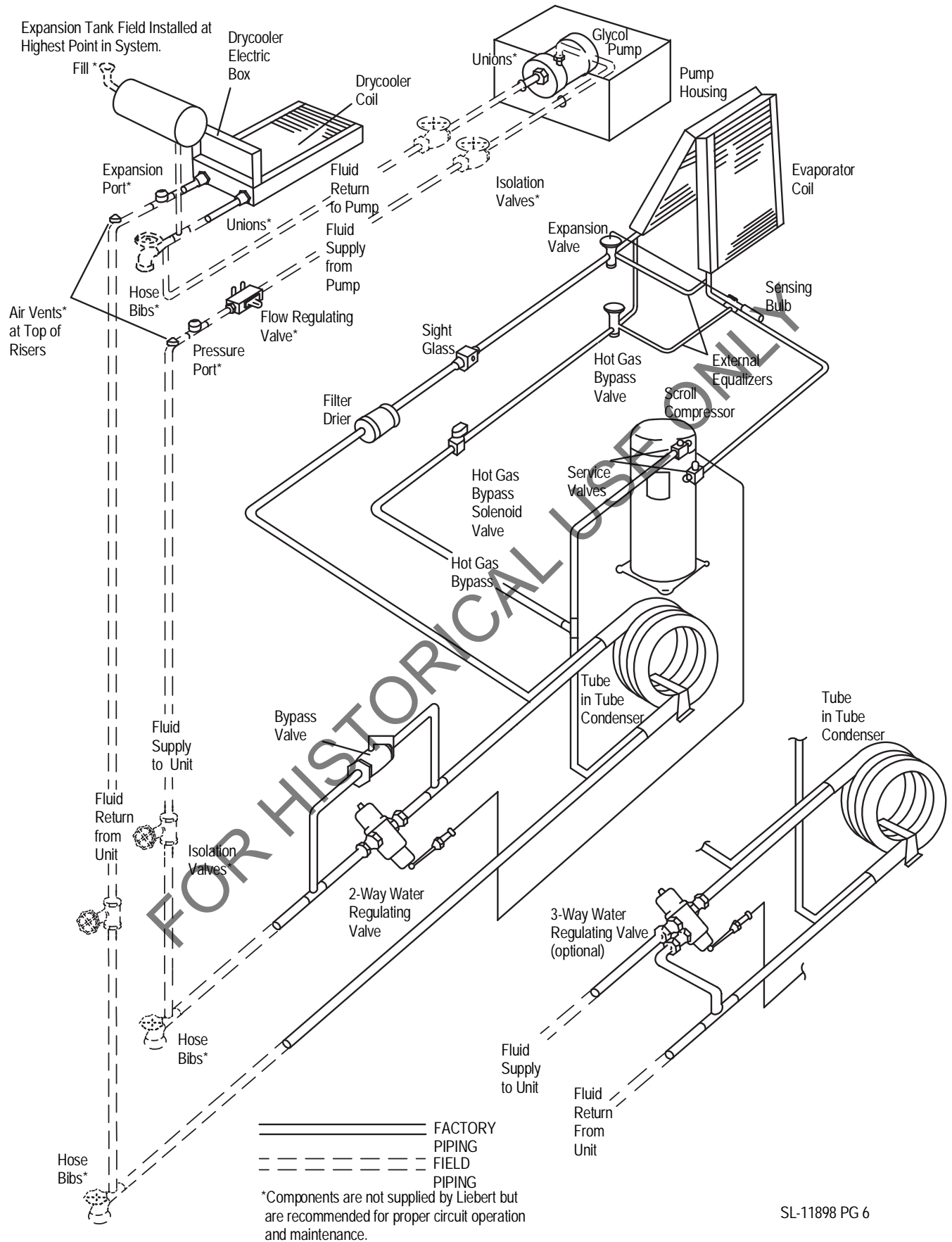
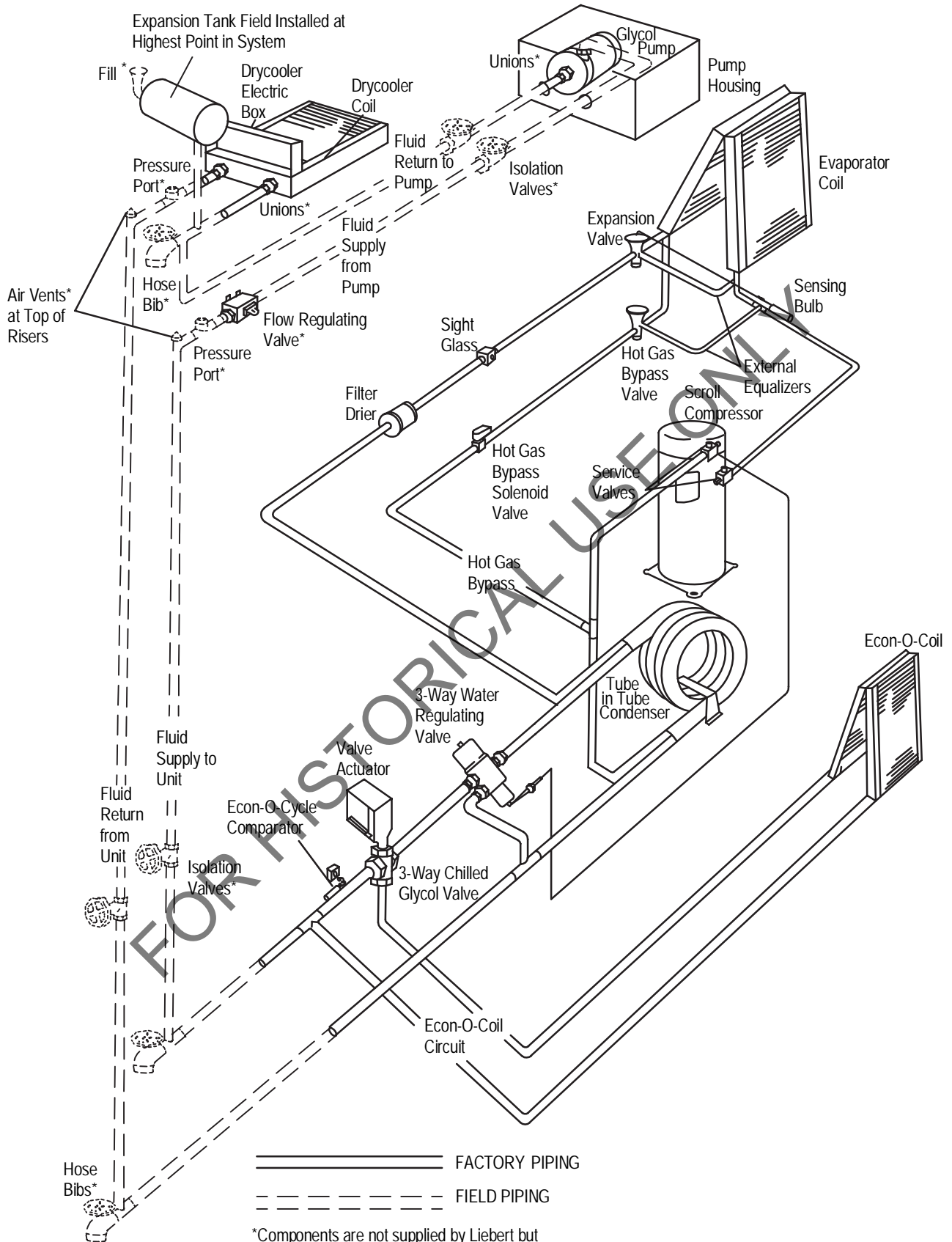

Figure 18 GLYCOOL general arrangement



5.6 Condenser

The condenser is designed to operate in conjunction with a drycooler. The maximum coolant pressure is 350 psig (2413 kPa).



NOTE

For pressures above 150 psig (1034 kPa), the high pressure option for high pressure valve(s) is required.

5.7 Glycol Regulating Valve

The glycol regulating valve automatically regulates the amount of coolant necessary to remove the heat from the refrigeration system, permitting more fluid to flow when load conditions are high and less fluid to flow when load conditions are low. The valve consists of a brass body, balance spring, valve seat, valve disc holders, capillary tube to discharge pressure, and adjusting screw.

5.7.1 Standard Valve - 150psig (1034kPa) System for 3 & 5 Ton Units (Johnson Controls Valve) High Pressure Valve - 350psig (2413kPa) System for 5 Ton Units (Johnson Controls Valve)

For details, refer to 4.3.1 - Standard Valve - 150psig (1034kPa) System for 3 & 5 Ton Units (Johnson Controls Valve) High Pressure Valve - 350psig (2413kPa) System for 5 Ton Units (Johnson Controls Valve).

5.7.2 High Pressure Valve - 350 psig (2413 kPa) System for 3 Ton Units (Metrex Valve)

For details, refer to 4.3.2 - High Pressure Valve - 350 psig (2413 kPa) System for 3 Ton Units (Metrex Valve).

5.7.3 Testing Valve Function

When the refrigeration system has been off for approximately 10-15 minutes, the coolant flow should stop.

Should the coolant continue to flow, the valve is either improperly adjusted or the pressure sensing capillary is not connected properly to the condenser.

Table 20 Refrigerant control settings psi (kPa)

Low Pressure Cut Out	Low Pressure Cut In	High Pressure Cut Out
20 (137.9)	65 (448.2)	360 (2482)

6.0 CHILLED WATER MODELS

6.1 Piping Considerations

Manual shut-off valves should be installed at the supply and return lines to each unit. This will provide for routine service and emergency isolation of the unit.

Consideration of the minimum water temperature to be supplied from the chiller will determine if the need exists to insulate supply and return lines. Insulation will prevent condensation on the supply and return lines.

To provide for the emergency of water leaks and the consequences of sub-floor flooding, floor drains should be provided with wet traps or a water detection system, such as a Liqui-tect, that is installed near the base of the unit or below the elevated floor.

Figure 19 Chilled water general arrangement - Upflow (BU)

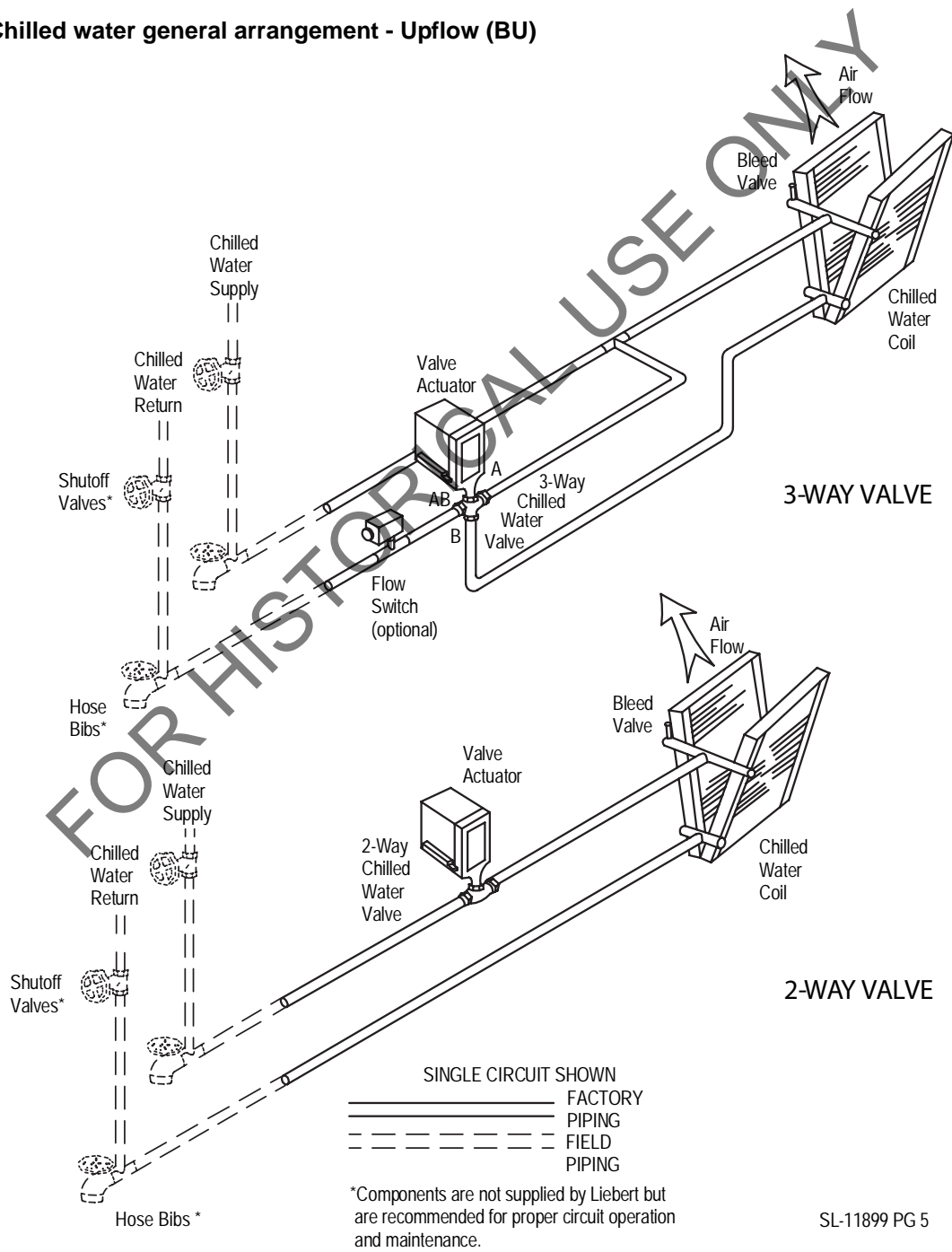
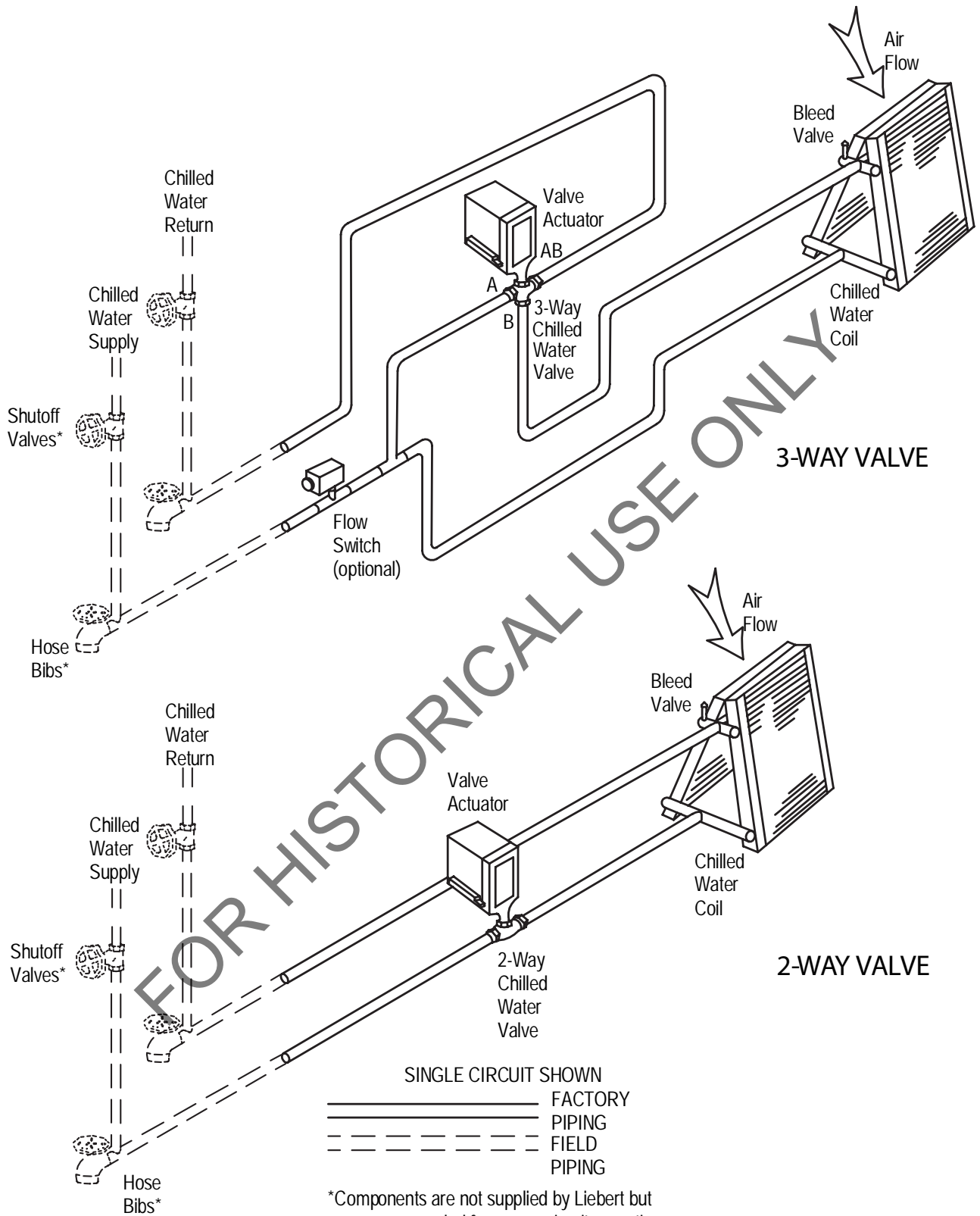

Figure 20 Chilled water general arrangement - downflow (BF) models



7.0 SPLIT SYSTEM MODELS

Three (3) condensing unit styles are available: two (2) air cooled and one (1) water/glycol cooled condensing unit.

7.1 Location Considerations

7.1.1 Air Cooled Condensing Units

To assure an adequate air supply, it is recommended that all condensing units be located in a clean air area, away from loose dirt and foreign matter that may clog the coil.

Condensing units must not be located in the vicinity of steam, hot air, or fume exhausts or closer than 18" from a wall, obstruction, or adjacent unit.

The outdoor condensing unit should be located for maximum security and maintenance accessibility. Avoid ground-level sites with public access or areas that will contribute to heavy snow accumulations. Do not allow the discharge air to blow into another condensing unit.

A solid base, capable of supporting the weight of the condenser and at least 2" (51 mm) higher than the surrounding grade and at least 2" (51 mm) larger than the condensing unit base dimensions, should be installed at the pre-determined location. In snow areas, a base of sufficient height to clear snow accumulation must be installed.

The centrifugal fan air cooled condensing unit may be located above the dropped ceiling or any remote indoor area. If noise is of concern, the condensing unit should be located away from personnel. Normal operating sound may be objectionable if the condensing unit is placed near quiet work areas.

To mount the unit in the ceiling, refer to **7.5.1 - Installing the Indoor Condensing Unit** for hanging guidelines and to **Figure 25 - Detail of ceiling hanging bracket** for dimensional data.

7.1.2 Water/Glycol Cooled Condensing Units

The condensing unit may be located above the dropped ceiling or any remote indoor area. If noise is of concern, the condensing unit should be located away from personnel. Normal operating sound may be objectionable if the condensing unit is placed near quiet work areas. To mount the unit in the ceiling, refer to **7.5.1 - Installing the Indoor Condensing Unit**.

7.2 Electrical Connections

Refer to equipment nameplate regarding wire size and circuit protection requirements. Refer to electrical schematic when making connections. Make all wiring and electrical connections in accordance with local and national codes.



WARNING

Use voltmeter to make sure power is turned off before making any electrical connections.

7.2.1 Line Voltage

Line voltage electrical service is required for all condensing units at the location of the condensing unit. This power supply does not have to be the same voltage as the indoor unit. This separate power source may be 208, 230, 460 or 575V, 60 Hz; or 200, 230, or 380/415V, 50 Hz. A disconnect switch is required and must be mounted per local and national codes to isolate the unit for maintenance.

7.2.2 Low Voltage

The control cable between the condensing unit and the evaporator unit is connected between terminals 1,2 and 3 on the terminal strip in the evaporator unit and the condensing unit control box. A fourth wire is required on systems with hot gas bypass. NEC Class 1 wiring is required. Glycol cooled units also require a two-wire control connection to the drycooler and pump package.

7.3 Piping Considerations

7.3.1 Refrigerant Loop



CAUTION

All local codes for handling refrigerant must be followed.



NOTE

As R22 and R407C are similar in properties, proper safety equipment and proper refrigeration tools are required on both types. Check unit nameplate for correct refrigerant type before topping off or recharging a system.



NOTE

Refrigerant R407C uses a POE (polyol ester) lubricant. The R407C refrigerant must be introduced and charged from the cylinder only as a liquid.



NOTE

When installing field piping, care must be taken to protect all refrigerant lines from the atmosphere, especially when using refrigerants with POE oils. Do not allow the piping to stand open to air for more than 15 minutes. Units designed for R407C have a compressor which contains POE oil that is very hygroscopic; that is, it quickly absorbs water from the air. The longer the compressor piping is left open to air, the harder it will be to fully evacuate. If left open too long, the POE oil may need to be replaced before achieving the required vacuum level.



NOTE

Complete all piping and evacuate lines before connecting quick connects when using an optional sweat adapter kit and field installed hard piping.

Follow all proper brazing practices including a dry nitrogen purge to maintain system cleanliness.

All split systems require two refrigerant lines (an insulated copper suction line and a copper liquid line) between the evaporator and the condensing unit.

Two possible methods exist for installing the copper suction and liquid lines.

1. Using an optional Sweat Adapter Kit and hard piping between the two units.
2. Using optional pre-charged line sets (for 3 ton R22 models only).

All refrigeration piping should be installed with high temperature brazed joints. Prevailing good refrigeration practices should be employed for piping supports, leak testing, evacuation, dehydration, and charging of the refrigeration circuits. The refrigeration piping should be isolated from the building by the use of vibration isolating supports.

It is important to handle the pre-charged lines for 3 ton units with care so they will not get kinked or damaged. Use tube benders and make all bends before making connections to either end. Coil any excess tubing in a horizontal plane with the slope of the tubing toward the condensing unit.

To prevent tube damage when sealing openings in walls and to reduce vibration transmission, use a soft flexible material to pack around the tubes.

When installing remote condensing units mounted above the evaporator, the suction gas line should be trapped at the evaporator. This trap will retain refrigerant oil in the off cycle. When the unit starts, oil in the trap is carried up the vertical riser and returns to the compressor.

Refrigerant charge requirements: Total refrigerant charge will be required only if units are evacuated during installation or maintenance. Total refrigerant charge = evaporator + lines + condensing unit.



NOTE

*All condensing units and 3-ton evaporator units are fully charged with refrigerant. All 5 ton evaporator units include a nitrogen holding charge only. See **Table 21** for field charge required. If field-supplied refrigerant piping is installed, refrigerant must be added to the system.*

Once all piping is complete, check for leaks and dehydrate the field piping as follows:

1. Pressurize the field piping to 150 PSIG (1034 kPa) using dry nitrogen with a trace of refrigerant. Check system for leaks with a suitable leak detector.
2. After completion of leak testing, release the test pressure (per local code) and pull a deep vacuum on the field piping with a suitable pump.
3. After 15 minutes, check the pressure readings and, if they have not changed, break vacuum with dry nitrogen. Pull a second vacuum to 250 microns or less. Recheck the pressure after 15 minutes.

Table 21 Unit refrigerant charge

Model	R22 Charge	R407C Charge	Model	R22 Charge	R407C Charge
	lbs (kg)	lbs (kg)		lbs (kg)	lbs (kg)
BF/BU 036E	0.56 (0.25)	0.5 (0.2)	PF_042A-_H	26.63 (12.08)	25.8 (11.7)
BF/BU 035E	0.56 (0.25)	0.5 (0.2)	PF_041A-_H	26.63 (12.08)	25.8 (11.7)
BF/BU 060E	0.81 (0.37)	0.8 (0.4)	PF_067A-_L	26.63 (12.08)	25.8 (11.7)
BF/BU 059E	0.81 (0.37)	0.8 (0.4)	PF_066A-_L	26.63 (12.08)	25.8 (11.7)
MC_40/39A	13.31 (6.04)	12.9 (5.8)	PF_Z67A-_L	51.69 (23.45)	50.1 (22.7)
MC_65/64A	27.00 (12.25)	26.1 (11.8)	PF_Z66A-_L	51.69 (23.45)	50.1 (22.7)
PF_042A-_L	13.31 (6.04)	12.9 (5.8)	PF_067A-_H	51.69 (23.45)	50.1 (22.7)
PF_041A-_L	13.31 (6.04)	12.9 (5.8)	PF_066A-_H	51.69 (23.45)	50.1 (22.7)
PF_Z42A-_L	26.63 (12.08)	25.8 (11.7)	MC_44/43W	3.38 (1.53)	n/a
PF_Z41A-_L	26.63 (12.08)	25.8 (11.7)	MC_69/68W	5.88 (2.67)	n/a

Table 22 Line charges - refrigerant per 100 ft (30 m) of Type "L" copper tube

O.D.	R22		R407C	
	Liquid Line lbs (kg)	Suction Line lbs (kg)	Liquid Line lbs (kg)	Suction Line lbs (kg)
1/2"	7.3 (3.3)	0.2 (0.1)	6.9 (2.9)	-
5/8"	11.7 (5.3)	0.3 (0.2)	11.0 (4.6)	0.4 (0.2)
7/8"	24.4 (11.1)	0.7 (0.3)	23.0 (9.6)	1.0 (0.4)
1-1/8"	41.6 (18.9)	1.2 (0.6)	39.3 (16.3)	1.7 (0.7)
1-3/8"	63.3 (28.7)	1.9 (0.8)	59.8 (24.8)	2.7 (1.1)

Table 23 Recommended refrigerant lines (R22 or R407C) sizes OD copper

Equivalent Feet (m)	3.5 Tons 036E (035E)		5 Tons 060E (059E)	
	Suction	Liquid	Suction	Liquid
0-50 (0-15)	7/8"	1/2"	1-1/8"	1/2"
51-100 (16-30)	1-1/8"	1/2"	1-1/8"	5/8"
101-150 (31-45)	1-1/8"	5/8"	1-3/8"	5/8"

Table 24 Line coupling sizes

Model (Tons)	Line Size OD Cu, in.	Coupling Size	Torque lb-ft.
3	3/8	#6	10-12
5	1/2 & 5/8	#10	35-45
3	7/8	#11	35-45
5	1-1/8	#12	50-65

Table 25 Equivalent lengths (feet) for various pipe fittings

Copper Pipe OD in.	90 Degree Elbow Copper	90 Degree Elbow Cast	45 Degree Elbow	Tee	Gate Valve	Globe Valve	Angle Valve
1/2	0.8	1.3	0.4	2.5	0.26	7.0	4.0
5/8	0.9	1.4	0.5	2.5	0.28	9.5	5.0
3/4	1.0	1.5	0.6	2.5	0.3	12.0	6.5
7/8	1.45	1.8	0.8	3.6	0.36	17.2	9.5
1-1/8	1.85	2.2	1.0	4.6	0.48	22.5	12.0
1-3/8	2.4	2.9	1.3	6.4	0.65	32.0	16.0
1-5/8	2.9	3.5	1.6	7.2	0.72	36.0	19.5

Refrigerant trap = 4 times equivalent length of pipe per this table

Figure 21 Refrigerant piping diagram

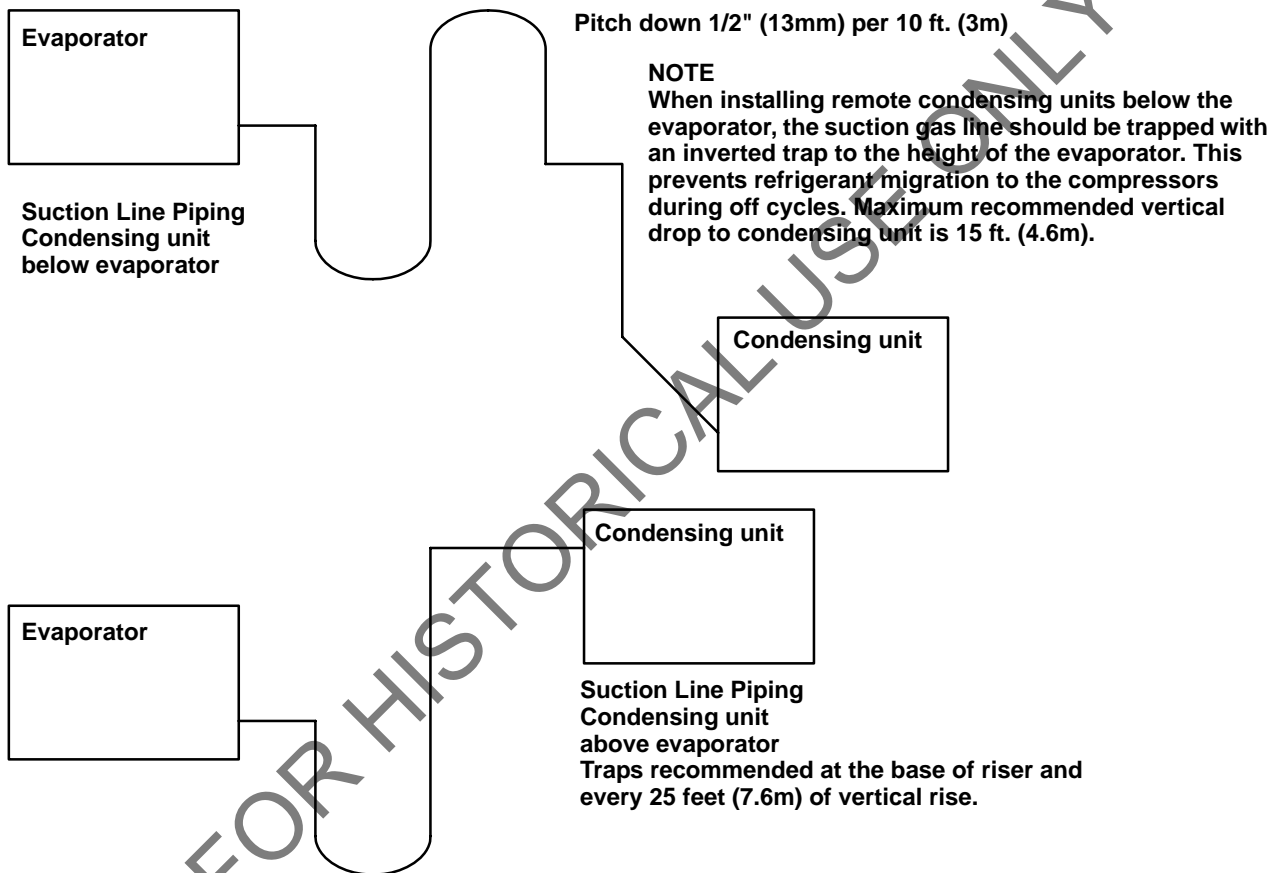

7.3.2 Quick Connect Fittings

**NOTE**

When hard piping is used, complete all piping and evacuate lines before connecting quick connects.

Be especially careful when connecting the quick connect fittings. Read through the following steps before making the connections.

1. Remove protector caps and plugs.
2. Carefully wipe coupling seats and threaded surfaces with a clean cloth.
3. Lubricate the male diaphragm and synthetic rubber seal with refrigerant oil.
4. Thread the coupling halves together by hand to ensure that the threads mate properly.
5. Tighten the coupling body hex nut and union nut with the proper sized wrench until the coupling bodies “bottom out” or until a definite resistance is felt.
6. Using a marker or pen, make a line lengthwise from the coupling union nut to the bulkhead.
7. Tighten the nuts an additional quarter turn; the misalignment of the lines shows how much the coupling has been tightened. This final quarter turn is necessary to ensure that the joint will not leak. Refer to **Table 24** for torque requirements.
8. Add charge for the additional piping (refer to **Table 22**).

FOR HISTORICAL USE ONLY

7.4 Outdoor Air Cooled Condensing Units

Figure 22 Outdoor air cooled condensing unit—horizontal air discharge models

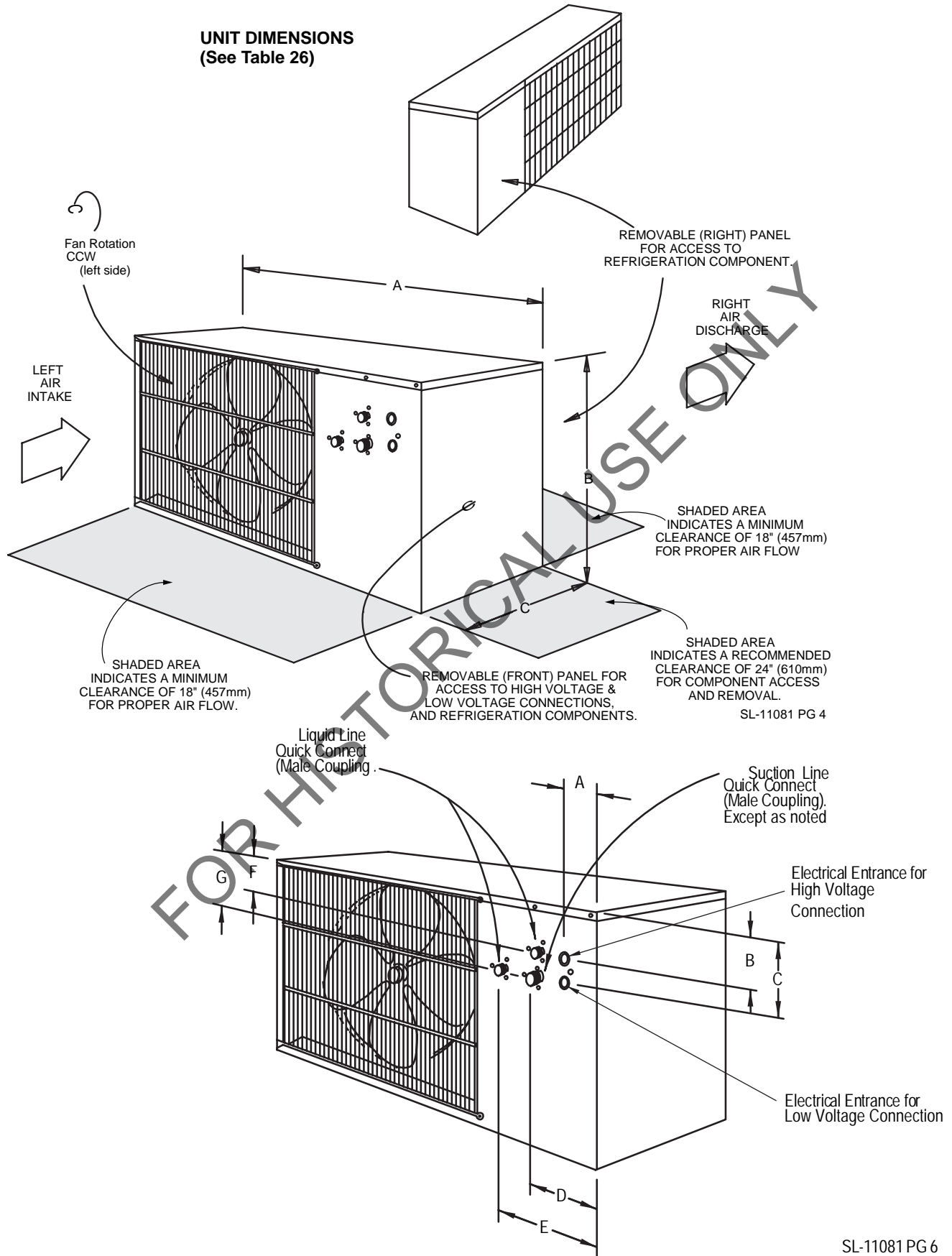

Table 26 Horizontal air discharge cabinet and floor planning dimensional data

Model Numbers		Dimensional Data in. (mm)			Module Weight lbs (kg) net
60 Hz	50 Hz	A	B	C	
PFC042A-_L	PFC041A-_L	48 (1219)	31 (787)	18 (457)	241 (109)
PFH042A-_L					
PFC042A-_H	PFC041A-_H	53 (1343)	36-1/4 (918)	18 (457)	351 (159)
PFH042A-_H					
PFCZ42A-_L	PFCZ41A-_L				
PFC067A-_L	PFC066A-_L				
PFH067A-_L					

Table 27 Horizontal air discharge piping and electrical connection data

Model Numbers		Dimensional Data in. (mm)			Piping Connections in. (mm)			
60 Hz	50 Hz	A	B	C	D	E	F	G
PFC042A-_L	PFC041A-_L	2 (51)	5-3/4 (146)	8-1/2 (216)	4-3/4 (121)	6-3/4 (171)	-	8-1/2 (216)
PFH042A-_L								
PFC042A-_H	PFC041A-_H	2 (51)	6 (152)	8-1/2 (216)	4-3/4 (121)	7-3/4 (197)	-	8-1/2 (216)
PFH042A-_H	PFCZ41A-_L							
PFCZ42A-_L								
PFC067A-_L	PFC066A-_L							
PFH067A-_L								

FOR HISTORICAL USE ONLY

Figure 23 Outdoor air cooled condensing unit—top air discharge models

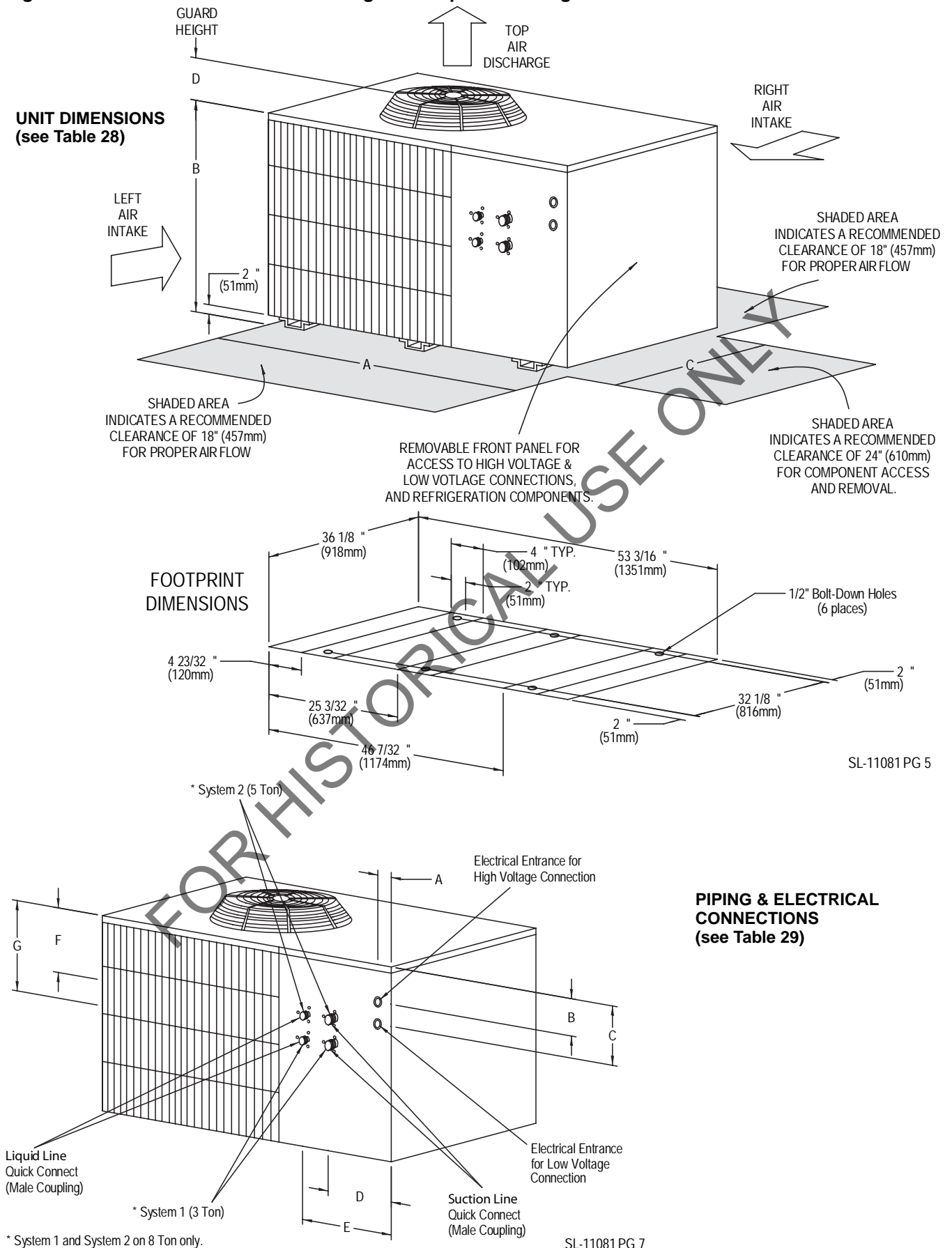

Table 28 Cabinet and floor planning dimensional data - prop fan condensing modules, top air discharge

Model Numbers		Dimensional Data in. (mm)				Module Weight lbs (kg) net
60 Hz	50 Hz	A	B	C	D	
PFC067A-_H	PFC066A-_H	53 (1343)	36-1/4 (918)	38-1/2 (978)	5-1/2 (140)	488 (222)
PFH067A-_H						
PFCZ67A-_L	PFCZ66A-_L					

Table 29 Piping and electrical connections - top air discharge

Model Numbers		Dimensional Data in. (mm)			Piping Connections in. (mm)		
60 Hz	50 Hz	A	B	C	D	E	F
PFC067A-_H	PFC066A-_H	2 (51)	6 (152)	8-1/2 (216)	4-3/4 (121)	7-3/4 (197)	8-1/2 (216)
PFH067A-_H							
PFCZ67A-_L	PFCZ66A-_L						

FOR HISTORICAL USE ONLY

Figure 24 Electrical field connections, prop fan condensing module

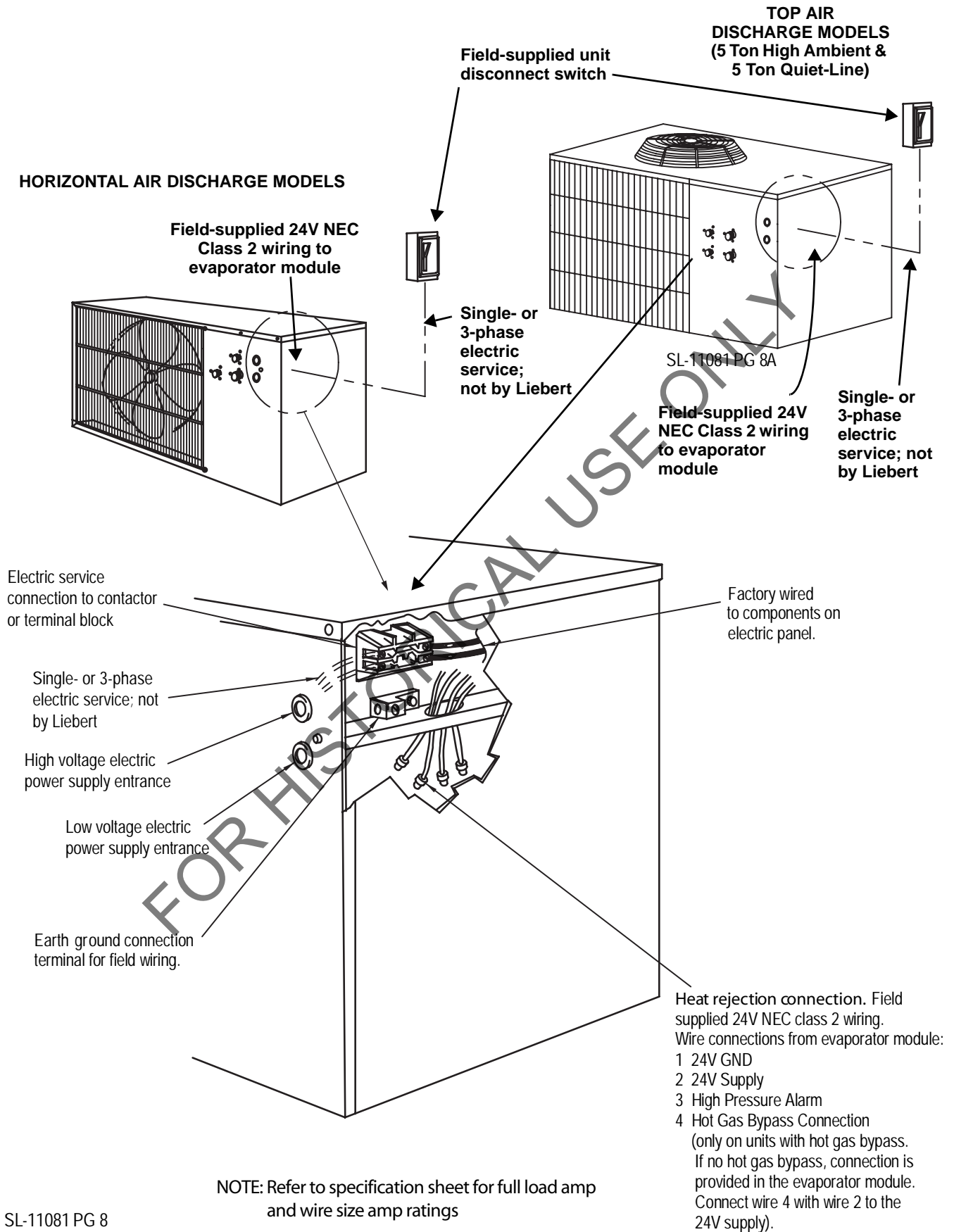

7.5 Centrifugal Air Cooled Condensing Units

7.5.1 Installing the Indoor Condensing Unit

Refer to drawings for unit dimensions and component locations.



WARNING

Be sure the supporting roof structure is capable of supporting the weight of the unit(s) and the accessories during installation and service. (See **Table 30 - Indoor centrifugal condensing unit.**)

Be sure to securely anchor the top ends of the suspension rods. Make sure all nuts are tight.

The indoor condensing unit is usually mounted above the ceiling and must be securely mounted to the roof structure. The ceiling and ceiling supports of existing buildings may require reinforcements. Be sure to follow all applicable codes. Use field-supplied threaded suspension rods and 3/8"-16 factory hardware kit.

Recommended clearance between ceiling grids and building structural members is unit height plus three inches.

Install the four field-supplied rods by suspending them from suitable building structural members. Locate the rods so that they will align with the four mounting holes in the flanges that are part of the unit base.

Using a suitable lifting device, raise the unit up and pass the threaded rods through the four mounting holes in the flanges that are part of the unit base.

Attach the threaded rods to the unit flanges using the supplied nuts and grommets. (See **Figure 25 - Detail of ceiling hanging bracket, Threaded Rod and Hardware Kit Installation.**) The rubber grommets provide vibration isolation.

1. Use the plain nuts to hold unit in place. Adjust these nuts so that the weight of the unit is supported evenly by the four rods, does not rest on the ceiling grid, and is level.



NOTE

The units must be level in order to operate properly.

2. Use the Nylock nuts to “jam” the plain nuts.

Table 30 Indoor centrifugal condensing unit

Model		Net Weight lbs (kg)
60 Hz	50 Hz	
MC_40A	MC_39A	240 (109)
MC_65A	MC_64A	449 (204)
MC_44W	MC_43W	190 (86)
MC_69W	MC_68W	282 (128)

Figure 25 Detail of ceiling hanging bracket

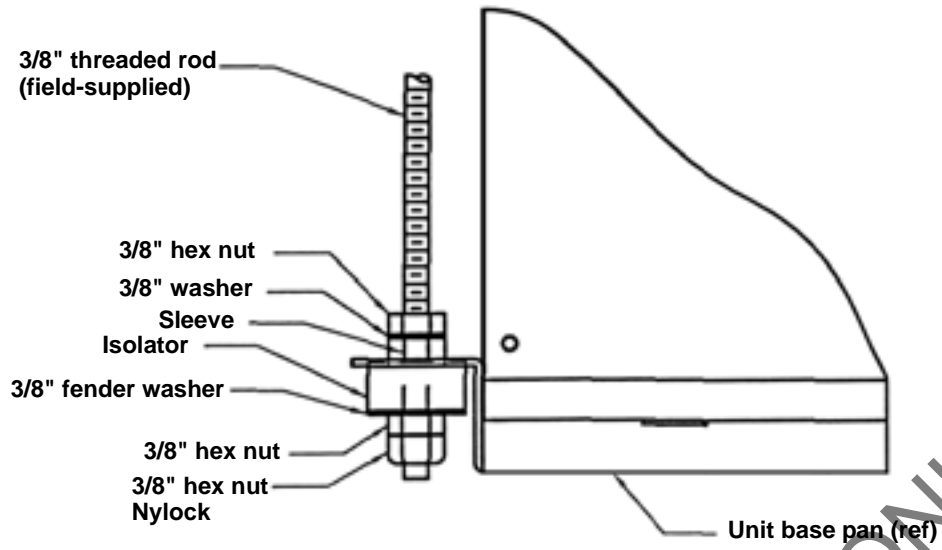

7.5.2 Ducting

The total external static pressure for the inlet and outlet ducts, including grille, must not exceed 0.5 inches of H₂O. Hood intake dimensions should be the same as the condensing unit duct dimensions.

If the condensing unit is located close to the outside of the building, rain hoods must be installed. In addition, install a triple layer bird screen over rain hood openings to eliminate the possibility of insects, birds, water, or debris entering the unit.

Use flexible ductwork or nonflammable cloth collars to attach ductwork to the unit and to control vibration transmission to the building. Attach the ductwork to the unit using the flanges provided. Locate the unit and ductwork so that the return air does not short circuit to the supply air inlet.

Avoid directing the hot exhaust air toward adjacent doors or windows.

Normal operating sound may be objectionable if the condensing unit is placed directly over quiet work areas. Ductwork that runs through a conditioned space or is exposed to areas where condensation may occur must be insulated. Whenever possible, ductwork should be suspended using flexible hangers. Ductwork should not be fastened directly to the building structure. In applications where the ceiling plenum is used as the heat rejection domain, the discharge air must be directed away from the condensing unit air inlet and a screen must be added to the end of the discharge duct to protect service personnel.

For multiple unit installations, space the units so that the hot condensing unit exhaust air is not directed toward the air inlet of an adjacent unit.

Table 31 Airflow CFM (CMH)

	3 Ton	5 Ton
60 Hz	2000 (3398)	3500 (5947)
50 Hz	1650 (2800)	3500 (5947)

Figure 26 2 and 3 ton centrifugal air cooled condensing unit dimensional data & piping connections

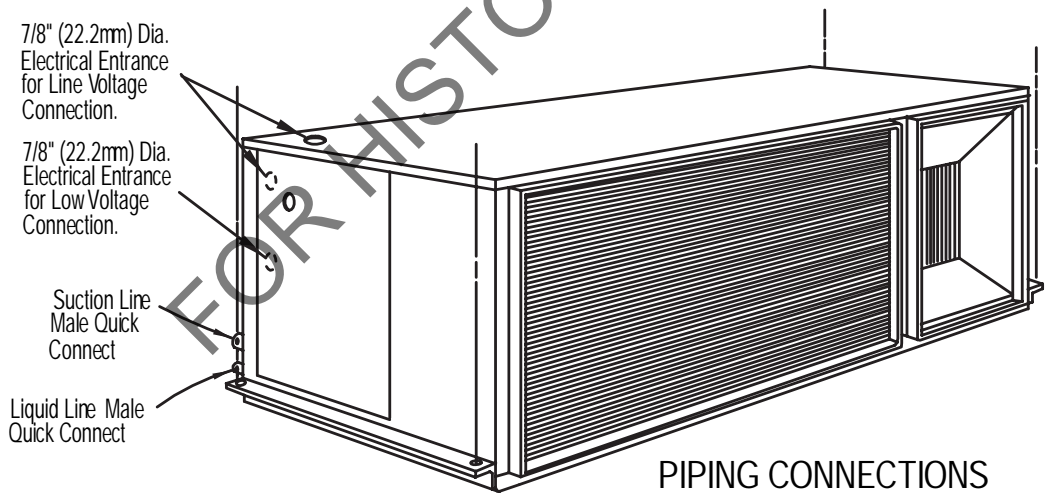
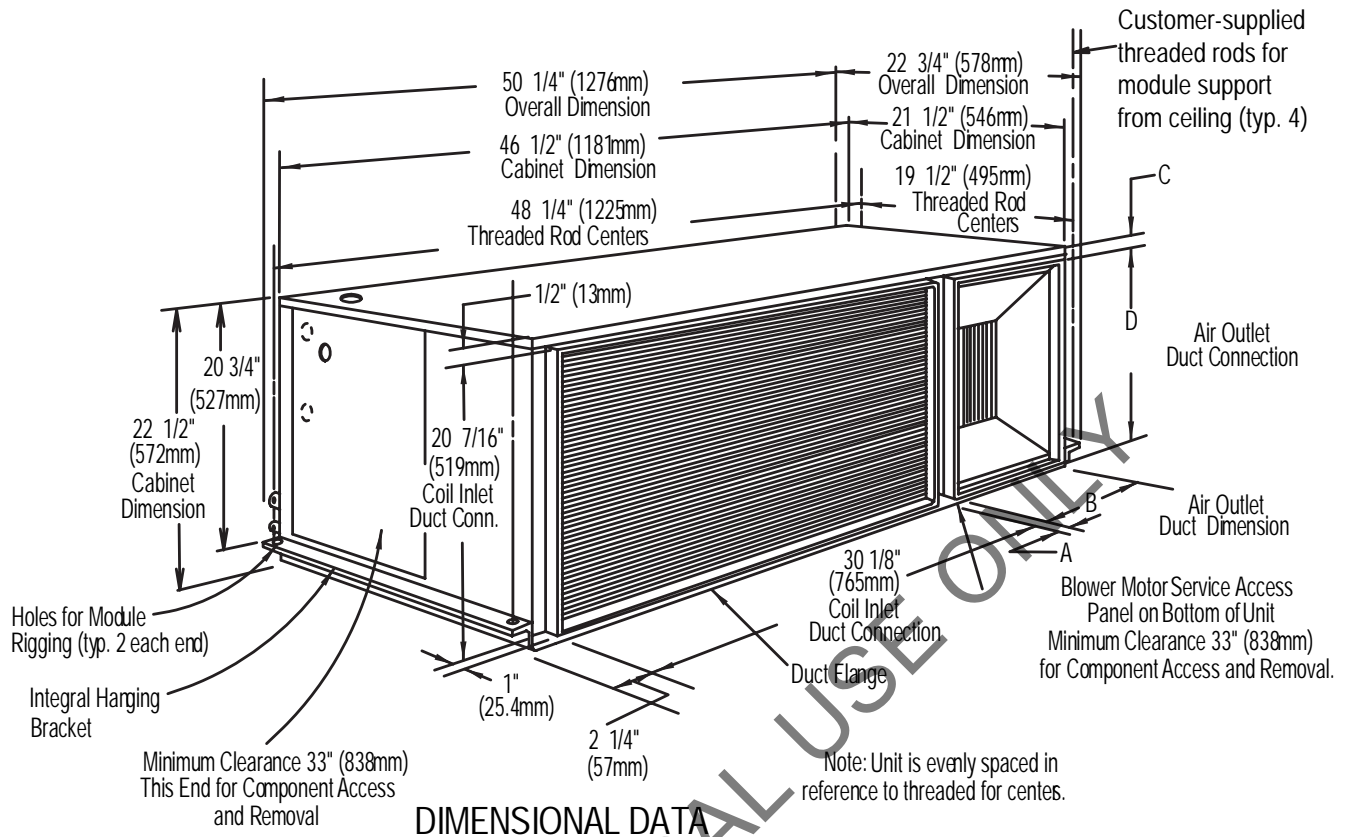

SL-11085 PG 4

Figure 27 3 ton centrifugal air cooled condensing unit (con't.)

Field-supplied unit disconnect switch when optional disconnect is not provided in unit

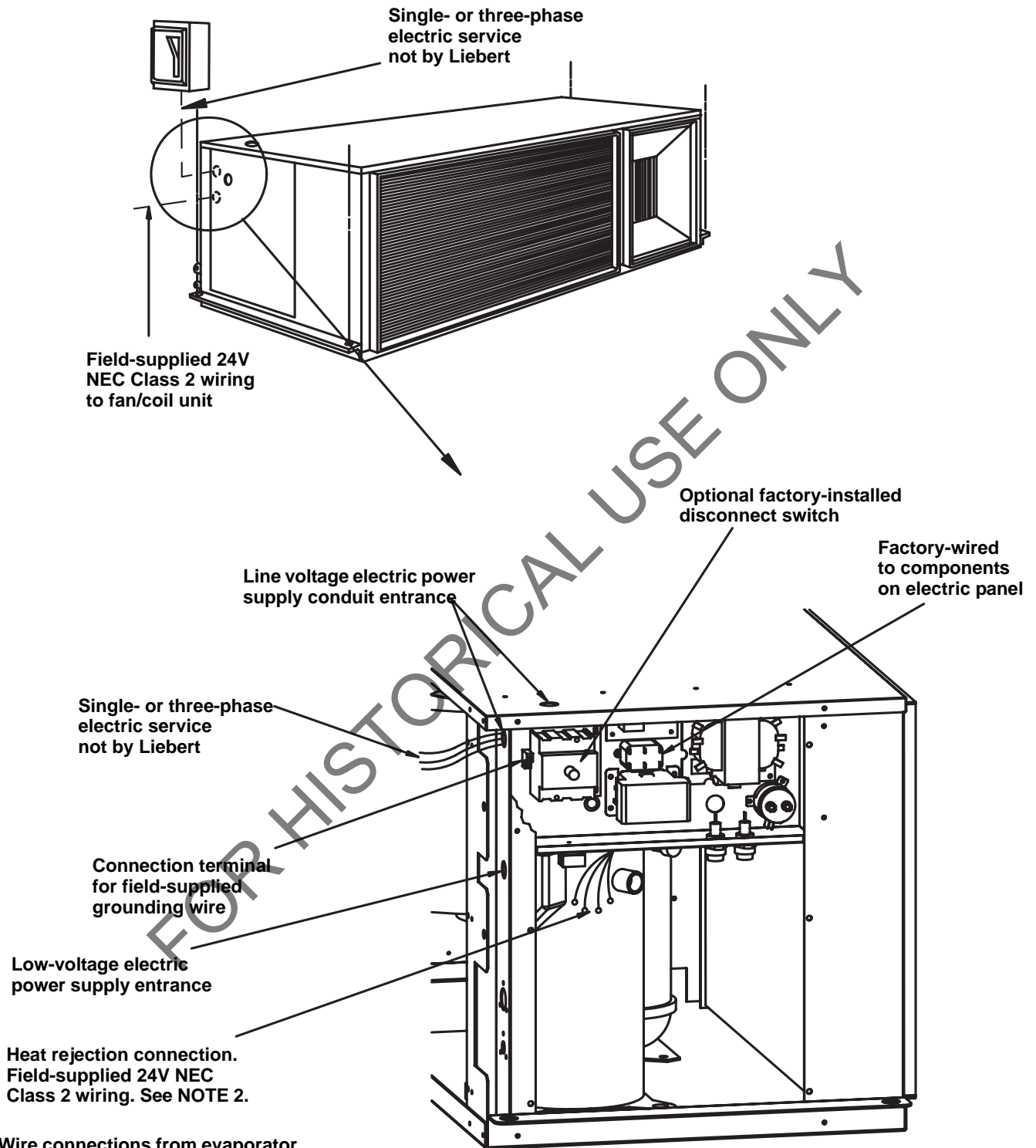

Wire connections from evaporator mod:

1. 24V ground
2. 24V supply
3. High-pressure alarm (optional)
4. Hot gas bypass connection (only on units with hot gas bypass)

NOTES:

1. Refer to specification sheet for full load amp. and wire size amp. ratings.
2. Control voltage wiring must be a minimum of 16 GA (1.6mm) for up to 75' (23m) or not to exceed 1 volt drop in control line.

DPN000207_Rev0

Figure 28 5 ton centrifugal air cooled condensing unit dimensional data

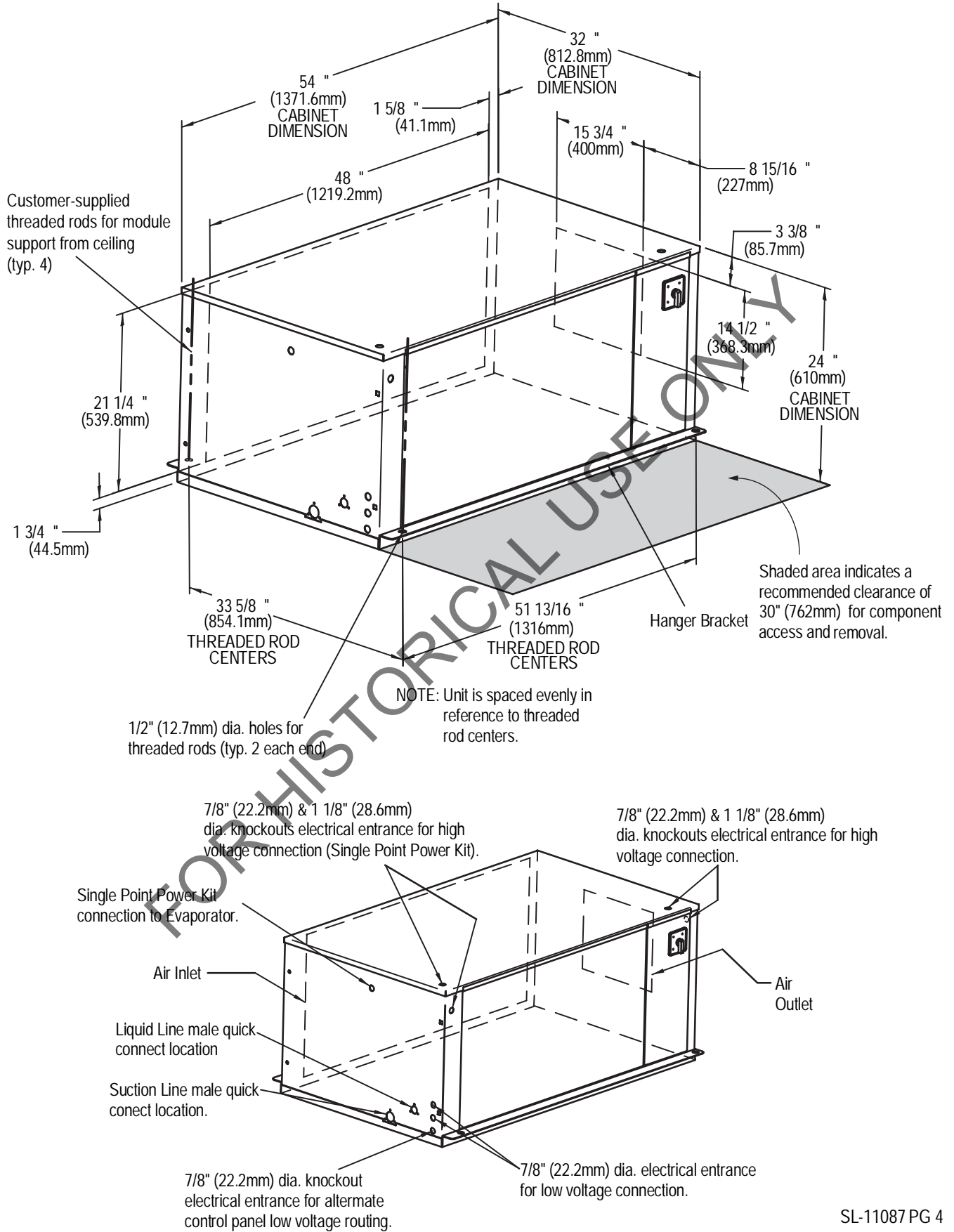
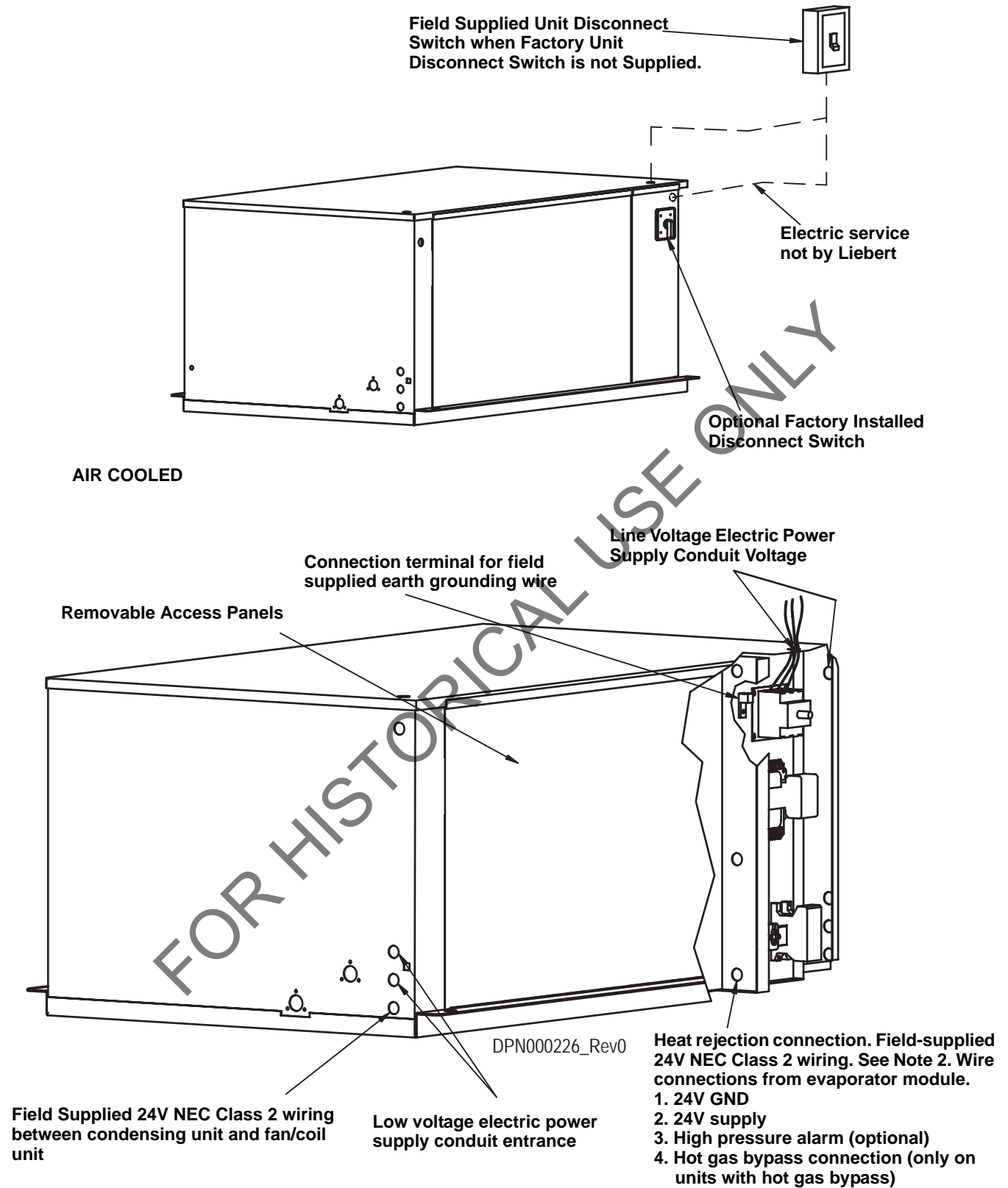

Figure 29 5 ton centrifugal air cooled condensing unit dimensional data (con't.)



NOTES:

1. Refer to specification sheet for full load amp and wire size amp ratings.
2. Control voltage wiring must be a minimum of 16 GA (1.6mm) for up to 75' (23m) or not to exceed 1 volt drop in control line.

Figure 30 Split systems general arrangement

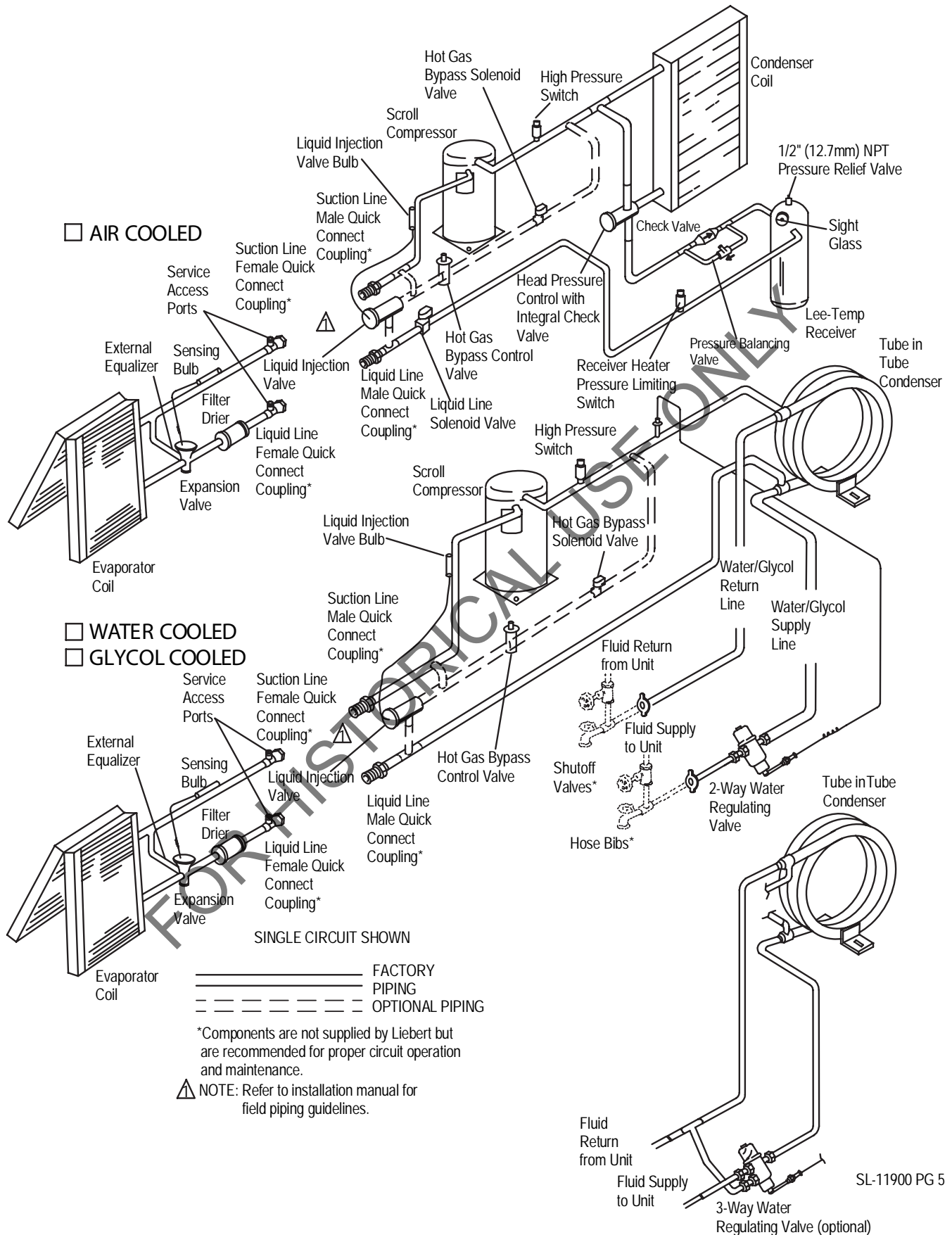

SL-11900 PG 5

7.6 Water and Glycol Cooled Condensing Units

For installation guidelines, refer to **Installing the Indoor Condensing Unit on page 52.**

7.6.1 Piping Considerations

It is recommended that manual service shut-off valves be installed at the supply and return line to each unit. This will provide for routine service or emergency isolation of the unit.

When the water source for the condenser is of poor quality, it is good practice to provide cleanable filters in the supply line. These filters will trap the particles in the water supply and extend the service life of the water cooled condenser.

3-Ton Connection Sizes

Condenser Water Inlet	7/8" OD Cu
Condenser Water Outlet	7/8" OD Cu
Suction Line	1-1/8" - 12 male #11 quick connect
Liquid Line:	5/8" - 18 male #6 quick connect

5-Ton Connection Sizes

Condenser Water Inlet	1-1/8" OD Cu
Condenser Water Outlet	1-1/8" OD Cu
Suction Line	1-7/16" - 16 male #12 quick connect
Liquid Line	1-1/16" - 12 male #10 quick connect

Table 32 Water and glycol cooled condensing unit data

Model	Net Weight		Glycol Volume	
	lbs	kg	gal	liters
MC_44W MC_43W	190	86	1.2	4.5
MC_69W MC_68W	282	128	2.0	7.6

7.6.2 Condenser Water Requirements

The standard maximum water pressure is 150 psig (1034 kPa). For applications above this pressure, consult the factory about high pressure systems.

The system will operate in conjunction with a cooling tower, city water, or drycooler.

7.6.3 Regulating Valve

For details, refer to sections **4.3.1 - Standard Valve - 150 psig (1034 kPa) System for 3 & 5 Ton Units (Johnson Controls Valve) High Pressure Valve - 350 psig (2413 kPa) System for 5 Ton Units (Johnson Controls Valve)**, **4.3.2 - High Pressure Valve - 350 psig (2413 kPa) System for 3 Ton Units (Metrex Valve)**, and **4.3.3 - Testing Valve Function.**

7.6.4 Glycol Systems

For split system glycol systems, use drycooler and pump data found in **5.0 - Glycol/GLYCOOL Cooled Models.** See **Table 18 - Drycooler data.**

Electrical control interconnect to drycooler is wired from water/glycol condensing unit.

Figure 31 2 and 3 ton water/glycol cooled condensing unit

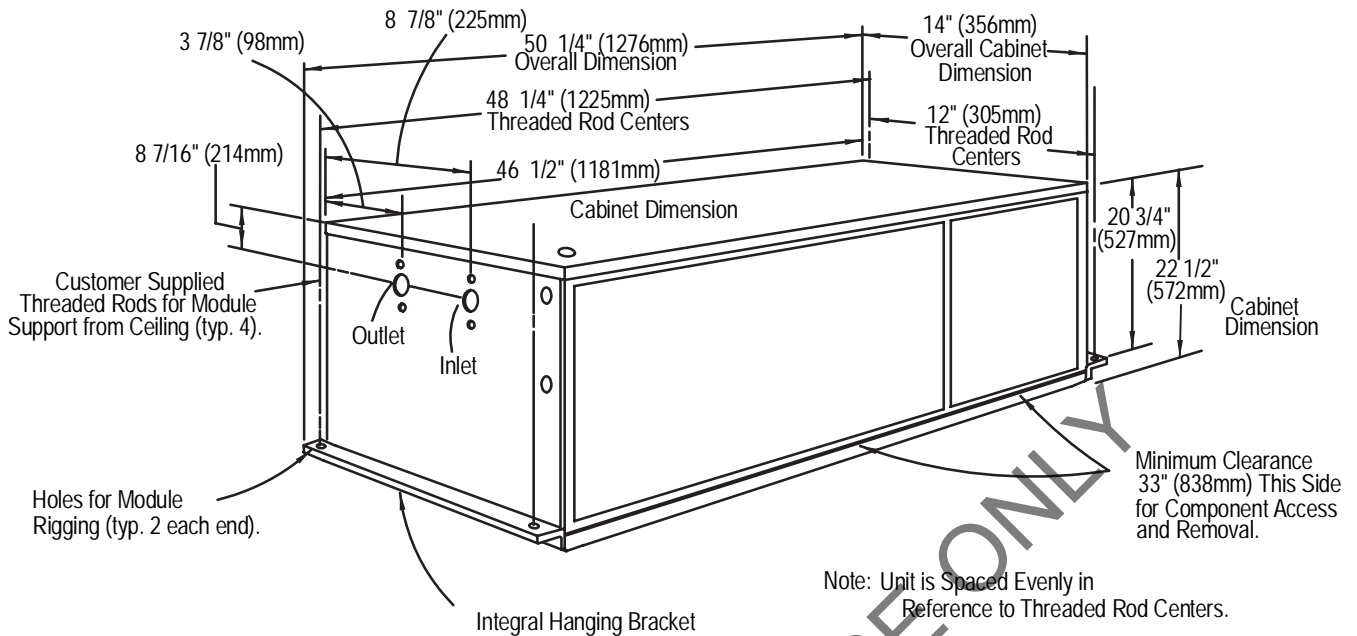

DIMENSIONAL DATA

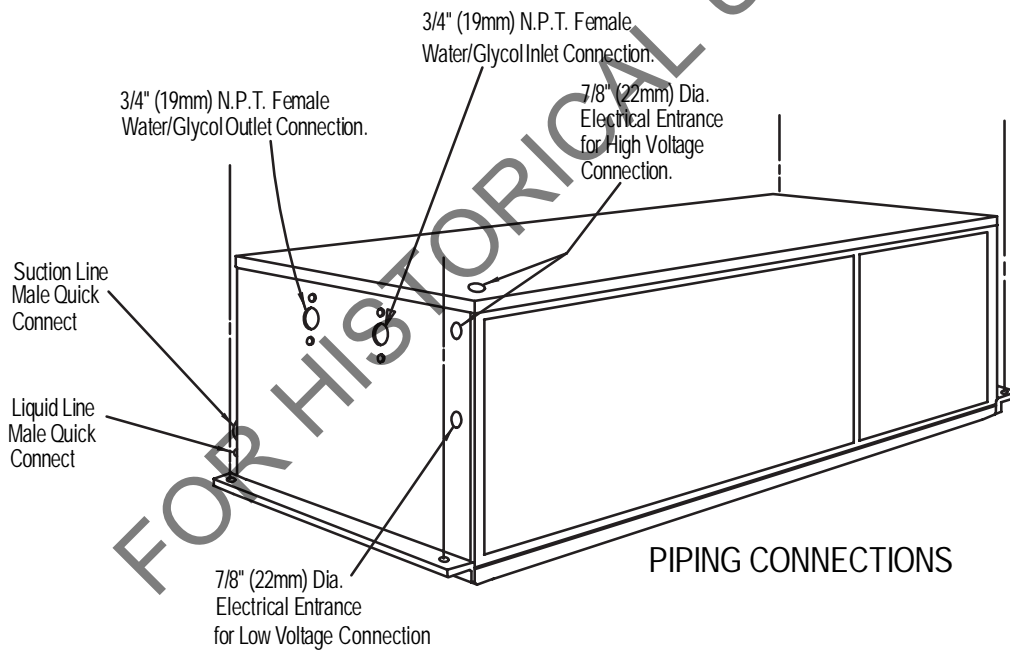

SL-11085 PG 6

Figure 32 3 ton water/glycol cooled condensing unit (con't.)

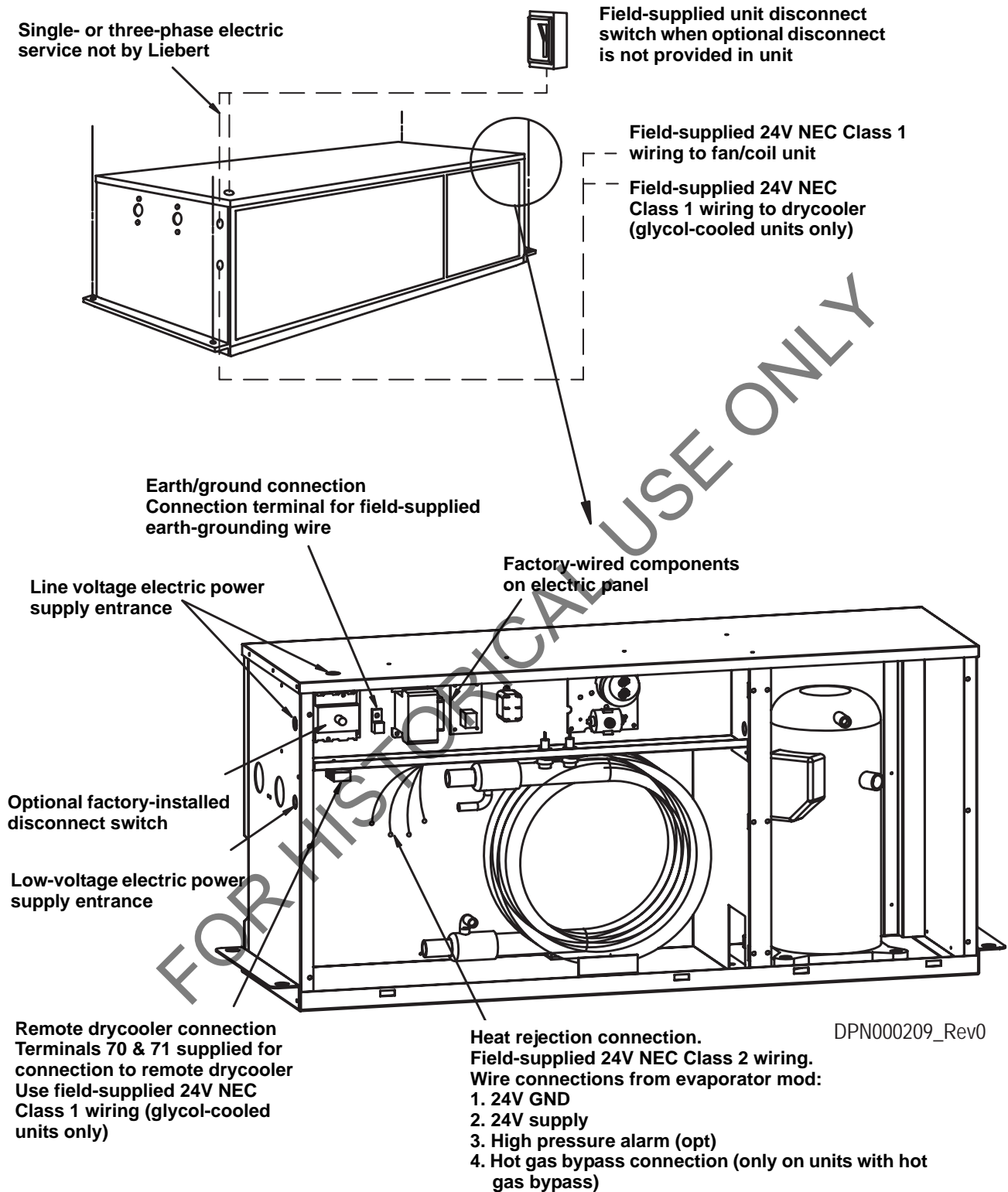

NOTES

1. Refer to specification sheet for full load amp. and wire size amp. ratings.
2. Control voltage wiring must be a minimum of 16 GA (1.6mm) for up to 75' (23m) or not to exceed 1 volt drop in control line.

Figure 33 5 ton water/glycol cooled condensing unit dimensional data

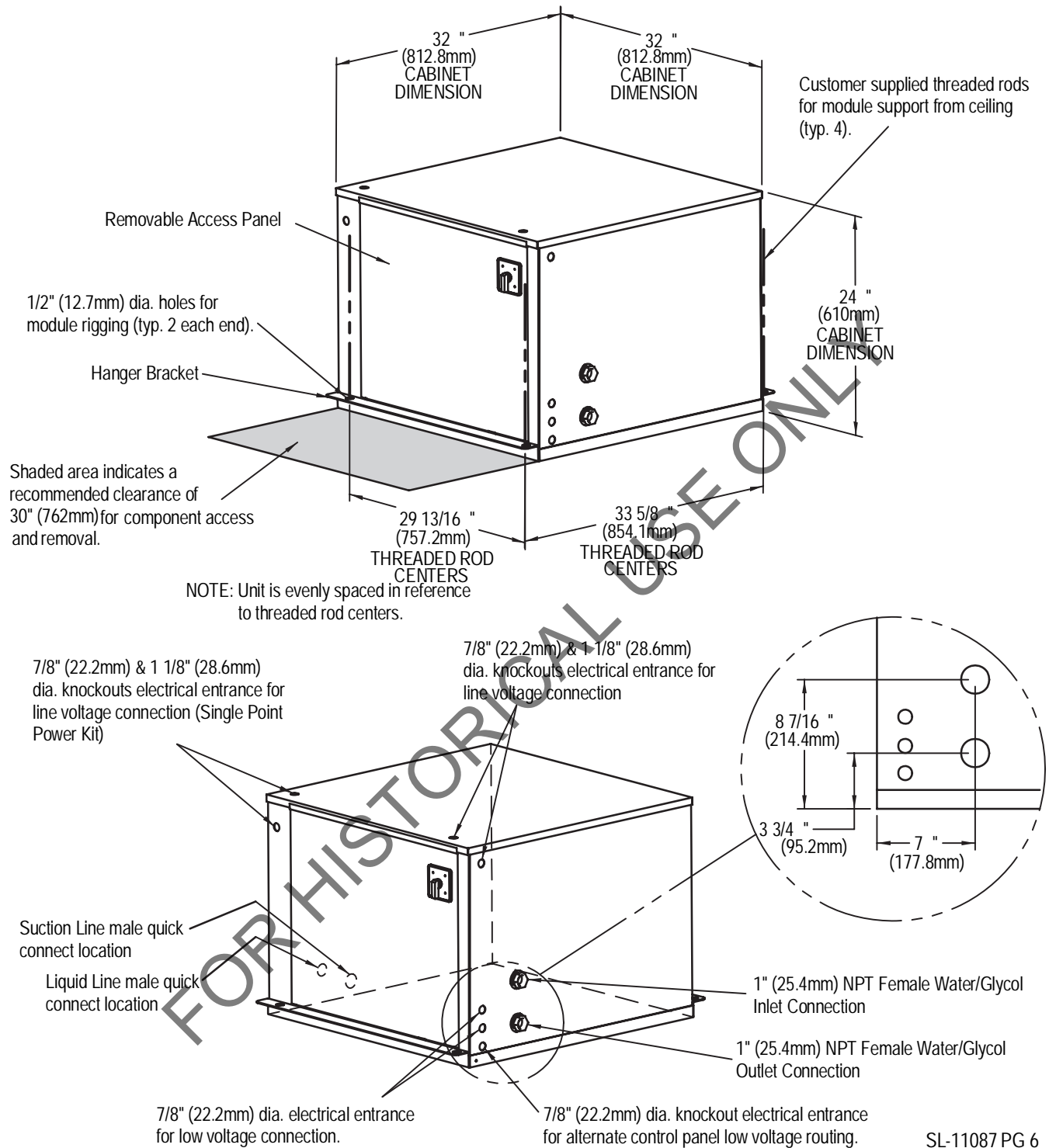
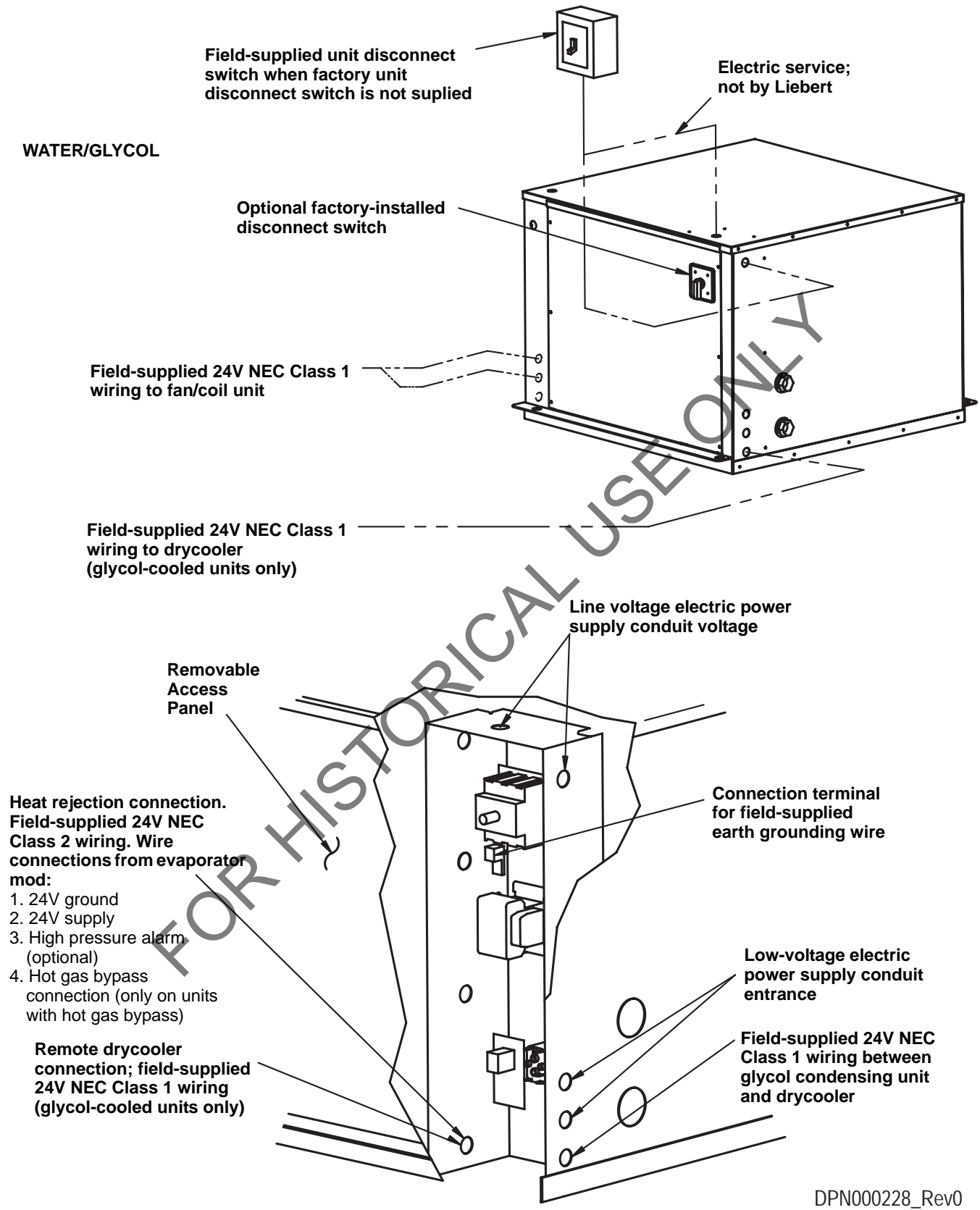

Figure 34 5 ton water/glycol cooled condensing unit (con't.)



DPN000228_Rev0

NOTES

1. Refer to specification sheet for full load amp. and wire size amp. ratings.
2. Control voltage wiring must be a minimum of 16 GA (1.6mm) for up to 75' (23m) or not to exceed 1 volt drop in control line.

8.0 R407C REFRIGERANT

Table 33 R407C pressure/temperature chart for operation and superheat (discharge/hot gas and suction gas)

Temperature		Gauge Pressure		Temperature		Gauge Pressure		Temperature		Gauge Pressure	
°F	°C	Psig	kPa	°F	°C	Psig	kPa	°F	°C	Psig	kPa
0.0	-17.8	18.9	130	35.0	1.7	54.8	378	70.0	21.1	114.9	792
1.0	-17.2	19.6	135	36.0	2.2	56.1	387	72.0	22.2	119.3	822
2.0	-16.7	20.4	141	37.0	2.8	57.5	396	74.0	23.3	124	853
3.0	-16.1	21.2	146	38.0	3.3	58.9	406	76.0	24.4	128	885
4.0	-15.6	22.0	152	39.0	3.9	60.3	415	78.0	25.6	133	917
5.0	-15.0	22.8	157	40.0	4.4	62.2	429	80.0	26.7	138	950
6.0	-14.4	23.6	163	41.0	5.0	63.1	435	82.0	27.8	143	984
7.0	-13.9	24.5	169	42.0	5.6	64.6	445	84.0	28.9	148	1019
8.0	-13.3	25.4	175	43.0	6.1	66.1	456	86.0	30.0	153	1054
9.0	-12.8	26.2	181	44.0	6.7	67.6	466	88.0	31.1	158	1091
10.0	-12.2	27.1	187	45.0	7.2	69.1	476	90.0	32.2	164	1128
11.0	-11.7	28.0	193	46.0	7.8	70.7	487	92.0	33.3	169	1167
12.0	-11.1	28.9	200	47.0	8.3	72.2	498	94.0	34.4	175	1206
13.0	-10.6	29.9	206	48.0	8.9	73.8	509	96.0	35.6	181	1246
14.0	-10.0	30.8	213	49.0	9.4	75.4	520	98.0	36.7	187	1287
15.0	-9.4	31.8	219	50.0	10.0	77.1	531	100.0	37.8	193	1329
16.0	-8.9	32.8	226	51.0	10.6	78.7	543	102.0	38.9	199	1372
17.0	-8.3	33.8	233	52.0	11.1	80.4	554	104.0	40.0	205	1416
18.0	-7.8	34.8	240	53.0	11.7	82.1	566	106.0	41.1	212	1461
19.0	-7.2	35.8	247	54.0	12.2	83.9	578	108.0	42.2	219	1507
20.0	-6.7	36.9	254	55.0	12.8	85.6	590	110.0	43.3	225	1553
21.0	-6.1	38.0	262	56.0	13.3	87.4	603	112.0	44.4	232	1601
22.0	-5.6	39.0	269	57.0	13.9	89.2	615	114.0	45.6	239	1650
23.0	-5.0	40.1	277	58.0	14.4	91.0	628	116.0	46.7	247	1701
24.0	-4.4	41.3	284	59.0	15.0	92.9	640	118.0	47.8	254	1752
25.0	-3.9	42.4	292	60.0	15.6	94.8	653	120.0	48.9	262	1804
26.0	-3.3	43.6	300	61.0	16.1	96.7	666	122.0	50.0	269	1858
27.0	-2.8	44.7	308	62.0	16.7	98.6	680	124.0	51.1	277	1912
28.0	-2.2	45.9	317	63.0	17.2	100.5	693	126.0	52.2	285	1968
29.0	-1.7	47.1	325	64.0	17.8	102.5	707	128.0	53.3	294	2025
30.0	-1.1	48.4	333	65.0	18.3	104.5	721	130.0	54.4	302	2083
31.0	-0.6	49.6	342	66.0	18.9	106.5	735	132.0	55.6	311	2143
32.0	0.0	50.9	351	67.0	19.4	108.6	749	134.0	56.7	320	2203
33.0	0.6	52.1	359	68.0	20.0	110.7	763	136.0	57.8	329	2265
34.0	1.1	53.5	369	69.0	20.6	112.8	778	138.0	58.9	338	2329
-	-	-	-	-	-	-	-	140.0	60.0	347	2393



NOTE

Use this table for superheat and for control adjustment (e.g., pressure switches). See **Table 34** for subcooling.

Table 34 R407C pressure/temperature chart for subcooling only (liquid measurements)

Temperature		Pressure Gauge		Temperature		Pressure Gauge		Temperature		Pressure Gauge	
°F	°C	Psig	kPa	°F	°C	Psig	kPa	°F	°C	Psig	kPa
36.0	2.2	73	500	59.0	15.0	114	786	94.0	34.4	203	1402
37.0	2.8	74	511	60.0	15.6	116	801	96.0	35.6	209	1444
38.0	3.3	76	522	61.0	16.1	118	815	98.0	36.7	216	1488
39.0	3.9	77	533	62.0	16.7	120	830	100.0	37.8	222	1532
40.0	4.4	79	544	63.0	17.2	123	845	102.0	38.9	229	1578
41.0	5.0	81	556	64.0	17.8	125	860	104.0	40.0	236	1624
42.0	5.6	82	567	65.0	18.3	127	875	106.0	41.1	242	1671
43.0	6.1	84	579	66.0	18.9	129	891	108.0	42.2	249	1720
44.0	6.7	86	591	67.0	19.4	131	906	110.0	43.3	257	1769
45.0	7.2	87	602	68.0	20.0	134	922	112.0	44.4	264	1819
46.0	7.8	89	615	69.0	20.6	136	938	114.0	45.6	271	1870
47.0	8.3	91	627	70.0	21.1	138	954	116.0	46.7	279	1922
48.0	8.9	93	639	72.0	22.2	143	987	118.0	47.8	287	1975
49.0	9.4	95	652	74.0	23.3	148	1021	120.0	48.9	294	2029
50.0	10.0	96	664	76.0	24.4	153	1055	122.0	50.0	302	2085
51.0	10.6	98	677	78.0	25.6	158	1090	124.0	51.1	310	2141
52.0	11.1	100	690	80.0	26.7	163	1126	126.0	52.2	319	2198
53.0	11.7	102	704	82.0	27.8	169	1163	128.0	53.3	327	2256
54.0	12.2	104	717	84.0	28.9	174	1201	130.0	54.4	336	2315
55.0	12.8	106	730	86.0	30.0	180	1239	132.0	55.6	345	2376
56.0	13.3	108	744	88.0	31.1	185	1279	134.0	56.7	354	2437
57.0	13.9	110	758	90.0	32.2	191	1319	136.0	57.8	363	2500
58.0	14.4	112	772	92.0	33.3	197	1360	138.0	58.9	372	2563
-	-	-	-	-	-	-	-	140.0	60.0	381	2628

**NOTE**

Use this table for subcooling calculation *ONLY*. See **Table 33** for superheat or control adjustment.

8.1 Calculating Subcooling

Example

Measure the liquid pressure (e.g., 200 psig). Find the liquid saturation temperature at that pressure on **Table 34** (e.g., 93°F). Measure the temperature of the liquid line (e.g., 90°F). Subtract the actual temperature from the liquid saturation temperature to obtain the subcooling (e.g., 93 – 90 = 3°F). If the actual temperature is greater than the liquid saturation temperature, then there is no subcooling, and the fluid may be a mixture of liquid and vapor.

Why There Are Two R407C Temperature and Pressure Tables

R407C is a blend of refrigerants that exhibits a temperature “glide” of approximately 8 to 12°F (4 to 7°C). This “glide” is the difference between the liquid and vapor saturation temperatures at a given pressure. Use the correct table for the saturation temperature you need. **Table 33** is for superheat or operating controls. **Table 34** is for subcooling only.

Notes

FOR HISTORICAL USE ONLY

FOR HISTORICAL USE ONLY

FOR HISTORICAL USE ONLY

Ensuring The High Availability Of Mission-Critical Data And Applications.

Emerson Network Power, the global leader in enabling business-critical continuity, ensures network resiliency and adaptability through a family of technologies—including Liebert power and cooling technologies—that protect and support business-critical systems. Liebert solutions employ an adaptive architecture that responds to changes in criticality, density and capacity. Enterprises benefit from greater IT system availability, operational flexibility and reduced capital equipment and operating costs.

While every precaution has been taken to ensure the accuracy and completeness of this literature, Liebert Corporation assumes no responsibility and disclaims all liability for damages resulting from use of this information or for any errors or omissions.
© 2006 Liebert Corporation
All rights reserved throughout the world. Specifications subject to change without notice.
® Liebert and the Liebert logo are registered trademarks of Liebert Corporation. All names referred to are trademarks or registered trademarks of their respective owners.

SL-11925_REV1_08-06

Emerson Network Power.

The global leader in enabling Business-Critical Continuity™.

- | | | | |
|--------------------|--------------------------------|-----------------------------|--------------------|
| ■ AC Power Systems | ■ Embedded Computing | ■ Outside Plant | ■ Services |
| ■ Connectivity | ■ Embedded Power | ■ Power Switching & Control | ■ Site Monitoring |
| ■ DC Power Systems | ■ Integrated Cabinet Solutions | ■ Precision Cooling | ■ Surge Protection |

Technical Support / Service Web Site

www.liebert.com

Monitoring

800-222-5877

monitoring@emersonnetworkpower.com

Outside the US: 614-841-6755

Single-Phase UPS

800-222-5877

upstech@emersonnetworkpower.com

Outside the US: 614-841-6755

Three-Phase UPS

800-543-2378

powertech@emersonnetworkpower.com

Environmental Systems

800-543-2778

Outside the United States

614-888-0246

Locations

United States

1050 Dearborn Drive

P.O. Box 29186

Columbus, OH 43229

Europe

Via Leonardo Da Vinci 8

Zona Industriale Tognana

35028 Piove Di Sacco (PD) Italy

+39 049 9719 111

Fax: +39 049 5841 257

Asia

7/F, Dah Sing Financial Centre

108 Gloucester Road, Wanchai

Hong Kong

852 2572220

Fax: 852 28029250