

**UPStation GXT™**

**6 & 10 kVA  
208V & 240V**

**USER MANUAL**  
English



## IMPORTANT SAFETY INSTRUCTIONS

**WARNING:** Opening or removing the cover may expose you to lethal voltages within this unit even when it is apparently not operating and the input wiring is disconnected from the electrical source. Observe all cautions and warnings in this manual. Failure to do so MAY result in serious injury or death. Refer all UPS and battery service to qualified service personnel. Do not attempt to service this product yourself. Never work alone.

1. SAVE THESE INSTRUCTIONS. THIS MANUAL CONTAINS IMPORTANT SAFETY INSTRUCTIONS. Read all safety, installation, and operating instructions before installing and operating the Uninterruptible Power System (UPS). Adhere to all warnings on the unit and in this manual. Follow all operating and user instructions. Individuals without previous training can operate this equipment.
2. This product is designed for Commercial/Industrial use only. It is not intended for use with life support and other designated "critical" devices. Maximum load must not exceed that shown on the UPS rating label. The UPS is designed for data processing equipment. If uncertain, consult your dealer. See Limited Warranty.
3. This UPS is designed for use on a properly grounded (earthed), 208-240 VAC, 50Hz or 60Hz supply, for installation by qualified personnel. A qualified electrician must review and approve customer supplied wiring, circuit breakers, intended loads, and verify correct input, output and ground connections to ensure compliance with technical standards and local electrical codes of practice. Installation instructions and warning notices only for use by qualified personnel are located after the UPS operator instructions in this manual.
4. ELECTROMAGNETIC COMPATIBILITY - The GXT 6 & 10 kVA complies with the limits for a Class A digital device, pursuant to Part 15 of FCC rules. These limits provide reasonable protection against harmful interference in a commercial environment. This device generates, uses, and radiates radio frequency energy and, if not installed and used in accordance with the instruction manual, may cause harmful interference to radio communications. Operating this device in a residential area is likely to cause harmful interference, which the user must correct at his own expense.
5. Operate the UPS in an indoor environment only in an ambient temperature range of 0°C to +40°C (32°F to +104°F). Install it in a clean environment, free from moisture, flammable liquids, gasses, or corrosive substances.
6. This UPS contains no user serviceable parts. The UPS ON/OFF pushbuttons do not electrically isolate internal parts. Under no circumstances attempt to gain access internally, due to the risk of electric shock or burn. Do not continue to use the UPS if the front panel indications are not in accordance with these operating instructions, or the UPS performance alters in use. Refer all faults to your dealer.
7. Only trained engineers authorized by Liebert should perform troubleshooting. To replace batteries, refer all servicing to qualified service personnel. PROPER DISPOSAL OF BATTERIES IS REQUIRED. REFER TO YOUR LOCAL LAWS AND REGULATIONS FOR DISPOSAL REQUIREMENTS.

8. Never block or insert any object into the ventilation holes or other openings.
9. DO NOT CONNECT equipment that could overload the UPS or demand DC current from the UPS, for example: electric drills, vacuum cleaners, laser printers, hairdryers or any appliance using half wave rectification.
10. Storing magnetic media on top of the UPS may result in data loss or corruption.
11. Turn the UPS off and isolate the UPS before cleaning. Use only a soft cloth, never liquid or aerosol cleaners. Keep the front and rear vents free of dust accumulation that could restrict airflow.

## GLOSSARY OF SYMBOLS

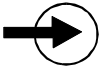

Indicates AC Input

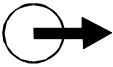

Indicates AC Output



Indicates Caution: Note the accompanying instruction



Indicates the position of a fuse



Requests the user to consult the manual for additional information



Indicates that the unit contains a valve regulated lead acid battery

## INTRODUCTION

Congratulations on your choice of the UPStation GXT™ Uninterruptible Power System (UPS). It provides conditioned power to microcomputers and other sensitive electronic equipment.

Upon generation, AC power is clean and stable. However, during transmission and distribution it may be subject to voltage sags, spikes, or complete power failure, which may interrupt computer operations, cause data loss, or even damage equipment. The UPStation GXT protects equipment from these disturbances.

The UPStation GXT is an “on-line” UPS that continuously conditions and regulates its output voltage, whether the utility power is present or not. It supplies connected equipment with clean sinewave power. Sensitive electronic equipment operates best from sinewave power. The GXT 6000/10000T-208X, and 240X models have an additional output isolation transformer.

For ease of use, the UPStation GXT contains a light emitting diode (LED) display to indicate either “load percentage” or “battery capacity” depending upon the mode of operation. It also provides self-diagnostics, a combination On/Alarm Silence/Manual Battery Test button, a combination Off/Bypass button, and two levels of alarms when the unit is operating on battery.

The UPStation GXT has an interface port for communications between the UPS and a LAN server or other computer system. This port provides detailed operating information including voltages, currents, and alarm status to the host system when used in conjunction with the SiteNet® 2 software. SiteNet® 2 software can also remotely control UPS operation.

# MAJOR COMPONENTS

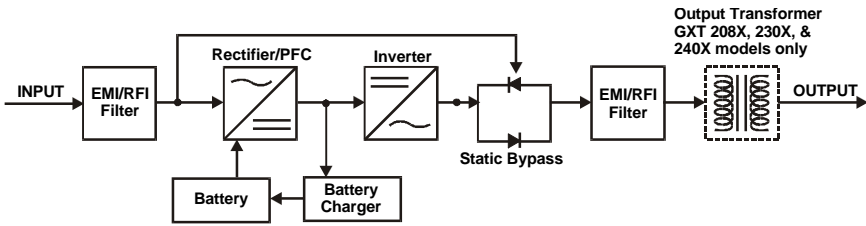

## EMI /RFI FILTERS

These UPS components provide surge protection, and filter both electromagnetic interference (EMI) and radio frequency interference (RFI). They minimize any surges or interference present in the utility line and keep the sensitive equipment protected.

## RECTIFIER/POWER FACTOR CORRECTION (PFC) CIRCUIT

In normal operation, the rectifier/power factor correction (PFC) circuit converts utility AC power to regulated DC power for use by the inverter, while ensuring that the wave shape of the input current used by the UPS is near ideal. Extracting this sinewave input current achieves two objectives: the utility power is used as efficiently as possible by the UPS, and the amount of distortion reflected on the utility is reduced. This results in cleaner power being available to other devices in the building not being protected by the UPStation GXT.

## INVERTER

In normal operation, the inverter utilizes the DC output of the power factor correction circuit and “inverts” it into precise, regulated sinewave AC power. Upon a utility power failure, the inverter receives its required energy from the battery through the Rectifier / PFC. In both modes of the operation, the UPS inverter is on-line and continuously generating clean, precise, regulated AC output power.

## BATTERY CHARGER

The battery charger utilizes energy from the Rectifier / PFC and precisely regulates it to continuously “float” charge the battery system. The battery system charges whenever the UPStation GXT is connected to utility power.

## BATTERY

The UPStation GXT employs valve regulated, nonspillable, lead acid batteries. At a typical room temperature (70° F) and with the UPS float charging, the battery system will last many years. Optional external battery cabinets are available to provide extended run times.

## **STATIC BYPASS**

The UPStation GXT provides an alternate path for utility power to the connected load, in the unlikely event of a UPS malfunction. Should the UPS have an overload, over temperature, or UPS failure condition, the UPS automatically transfers the connected load to **BYPASS** providing the bypass voltage is within specification. **BYPASS** operation is indicated by an alarm and an illuminated **BYPASS** LED (other LED's may be illuminated to indicate any diagnosed problem). The load may also be transferred to BYPASS using the control panel. **NOTE:** The **BYPASS** power path does NOT protect the connected equipment from disturbances on the utility supply and its range of operation is limited to +/- 17% of the nominal input supply voltage.

## **AUTO RE-START**

Upon restoration of the utility AC power after a utility power outage and complete battery discharge, the UPS will automatically restart and supply power to the critical load and the battery charger will automatically recharge the battery.

# INSTALLATION

These instructions are for use by competent personnel only.

## INSTALLATION CONSIDERATIONS

Detailed instructions to help you install the UPS are provided in the following pages; however, you should give some consideration to the proposed environment in which the UPS is to be installed, and carry out some preparatory work.

## UNPACKING AND INSPECTION

Follow unloading instructions printed on the carton. Do not discard any packaging until installation is complete, check that you have removed to a safe place the user manual, stabilizing brackets, and any other items shipped with the unit to be used in its installation.

**CAUTION:** GXT6000 UPS weighs up to 173kg (381lbs) and the GXT10000 UPS weighs up to 287kg (633lbs). Use adequate handling aids when moving or installing the UPS. The UPS is fitted with castor wheels for easy movement. Take care when the UPS is removed from its packing and being wheeled across an uneven floor without the stabilizers fitted, that it does not tip over.

Before you install the UPS, give it a thorough visual examination to ensure it has not been subjected to shipping damage. If it is not in perfect condition, you should advise both the shipper and the supplier immediately. **DO NOT ATTEMPT TO INSTALL A DAMAGED UPS.**

**IMPORTANT** - Check the UPS rating plate that the UPS is suitable for operation on your UTILITY voltage and load voltage requirements before installing.

## LOCATION

Locate the UPStation GXT indoors in a controlled environment, where it cannot be accidentally disconnected. Locate it in an area with unrestricted airflow, away from water, flammable liquids, gases, corrosives, or conductive contaminants.

Air vents are located at the front and the rear of the UPS. Do not position the UPS in an enclosed space where airflow is restricted. Allow at least 150mm (6 inches) free space around the UPS, with a minimum of 300mm (12 inches) at the back to enable easy operator access to the rear panel mounted input/output/battery circuit breakers.

Electrical maintenance/servicing requires access to all four sides of the UPS, provide the necessary free space or use a flexible wiring system to allow the UPS to be pulled forward.

Maintain an ambient temperature range of 0 - +40° centigrade (32-104° F)

**NOTE-** UPS operation in temperatures above 25°C (77°F) reduces battery life.

Model	AIRFLOW		DISSIPATION*		OUTPUT RATING**	
	Cfm	m <sup>3</sup> h	Watts	K Btu/hr	VA	Watts
GXT6000T	130	221	504	1.7	6000	4200
GXT10000T	270	459	840	2.8	10000	7000

\* Increase dissipation 25% for 208X, and 240X transformer models.

\*\* Decrease output rating 10% for 208 and 208X model.

## ELECTRICAL INSTALLATION CONSIDERATIONS

This UPS must be installed by competent electrical personnel and wired in accordance with local/national electrical codes.

The following information is provided for your guidance.

On start-up, the UPS will take a half cycle inrush current of up to 3 times the rated current. This must be taken into account when selecting the overload protection device at the input Utility supply distribution point. To avoid random tripping on start-up, we recommend that the input Utility supply be protected with an MCB capable of withstanding this initial inrush.

The utility input supply cable must be connected to the UPS via a wall mounted double pole circuit breaker, rated to carry the input current and be capable of breaking the maximum prospective short circuit current of this branch circuit. The breaker is to be mounted within six feet of the UPS and be readily accessible to the operator.

## ELECTRICAL CONNECTIONS

The UPS is supplied with an input/output/battery terminal block assembly on the rear of the UPS within a cable box. (see outline drawing) The cable box (gland plate) can be removed to enable knockouts to be removed, or new holes drilled, to secure the cables.

The cable sizes and distribution methods used during installation are subject to local/national electrical codes of practice, and therefore are not detailed here. The following tables detail the standard current ratings. The UPS rating plate gives details of the current ratings for alternative output voltages.

The terminals will accept wire sizes up to the values below:

GXT6000 = 8 AWG                      Recommended for all GXT6000 wiring.

GXT10000 = 6 AWG                    Recommended for all GXT10000 wiring.

(75°C copper wire)

Terminal tightening torque is 35 in-lb.



**Connecting the UPS Power cables**

Power cables connect to screw terminals on a terminal block that is located behind the rear mounted cable box (see figure). Permanent wiring must be routed to the cable box using appropriate materials as required by local codes.

**Connection of optional remote battery cabinets**

Full installation instructions are provided with these cabinets. Safety/EMC certification limits the use of these terminals to Liebert supplied options.

**Properly grounded (earthed) equipment provide multiple benefits**

High quality ground (earth) connections are required for the equipment ground conductors (protective earth) and grounding electrode conductor (power system earth connection) to reduce electrical noise and provide for safe operation of the UPS and connected loads. Conduit used alone without a grounding conductor wire is not an acceptable connection. Size ground (protective earth) conductors equal to circuit conductors.

## GXT6000T / 10000T - 208 UPS ONLY

Models whose part number ends with a “208” are NOT fitted with an isolating output transformer and are NOT separately derived sources under the NEC. The output L1 terminal is connected to the input L1 terminal and must not be connected to ground at the UPS (see NEC 250-5d, 250-26, 250.91, 250.92).

### GXT6000T-208 CONNECTIONS

CONNECTION	CURRENT RATING	Recommended Wire Size	Recommended External Overcurrent Protection
INPUT	28 AMPS	8 AWG (10 mm <sup>2</sup> )	40 AMPS
OUTPUT	26 AMPS	8 AWG (10 mm <sup>2</sup> )	
BATTERY	23 AMPS	8 AWG (10 mm <sup>2</sup> )	

SIZE GROUNDING (PROTECTIVE EARTH) CONDUCTORS EQUAL TO CIRCUIT CONDUCTORS

### GXT10000T-208 CONNECTIONS

CONNECTION	CURRENT RATING	Recommended Wire Size	Recommended External Overcurrent Protection
INPUT	45 AMPS	6AWG (16 mm <sup>2</sup> )	60 AMPS
OUTPUT	43 AMPS	6AWG (16 mm <sup>2</sup> )	
BATTERY	37 AMPS	6AWG (16 mm <sup>2</sup> )	

SIZE GROUNDING (PROTECTIVE EARTH) CONDUCTORS EQUAL TO CIRCUIT CONDUCTORS

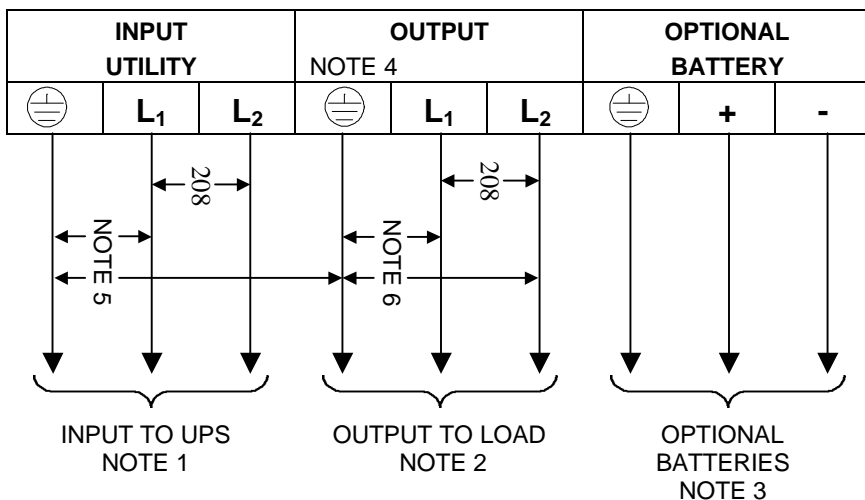

## **NOTES FOR GXT6000T / 10000T - 208 UPS ONLY**

1. The installer must provide circuit breaker protection according to local codes. The UTILITY disconnect must be within sight of the UPS. Maintain service space around the UPS or use flexible conduit.
2. The installer must provide output distribution panels and circuit breaker protection according to local codes. Output circuits must not share a common conduit with input circuits or any other wiring.
3. Refer to the manual provided with any optional battery cabinets.
4. This unit does NOT contain an isolating transformer. It is NOT a separately derived source. System grounding is provided at the UTILITY. Do not connect any output circuit conductor to ground at the UPS.
5. The UTILITY may be derived from a single-phase or three-phase source. The line to ground voltages are dependant upon the grounding of the UTILITY. Do not use a floating AC source.
6. Output L1 is connected directly to the Input L1. The line-ground voltages will match the input line-ground voltages.

# GXT6000T / 10000T - 208X UPS ONLY

Models whose part number ends with a “208X” are fitted with a single-phase isolating output transformer and are separately derived sources. The output neutral is already bonded to ground on the output terminals with a Bonding Jumper (see NEC 250-5d, 250-26, 250.91, 250.92). The output L1 and L2 terminals are not connected to the input L1 and L2.

## GXT6000T-208X CONNECTIONS

CONNECTION	CURRENT RATING	Recommended Wire Size	Recommended External Overcurrent Protection
INPUT	28 AMPS	8 AWG (10 mm <sup>2</sup> )	40 AMPS
OUTPUT @ 208V	26 AMPS	8 AWG (10 mm <sup>2</sup> )	
OUTPUT @ 120V	45 AMPS	8 AWG (10 mm <sup>2</sup> )	
BATTERY	33 AMPS	8 AWG (10 mm <sup>2</sup> )	

SIZE GROUNDING (PROTECTIVE EARTH) CONDUCTORS EQUAL TO CIRCUIT CONDUCTORS

## GXT10000T-208X CONNECTIONS

CONNECTION	CURRENT RATING	Recommended Wire Size	Recommended External Overcurrent Protection
INPUT	45 AMPS	6AWG (16 mm <sup>2</sup> )	60 AMPS
OUTPUT @ 208V	43 AMPS	6AWG (16 mm <sup>2</sup> )	
OUTPUT @ 120V	75 AMPS	6AWG (16 mm <sup>2</sup> )	
BATTERY	39 AMPS	6AWG (16 mm <sup>2</sup> )	

SIZE GROUNDING (PROTECTIVE EARTH) CONDUCTORS EQUAL TO CIRCUIT CONDUCTORS

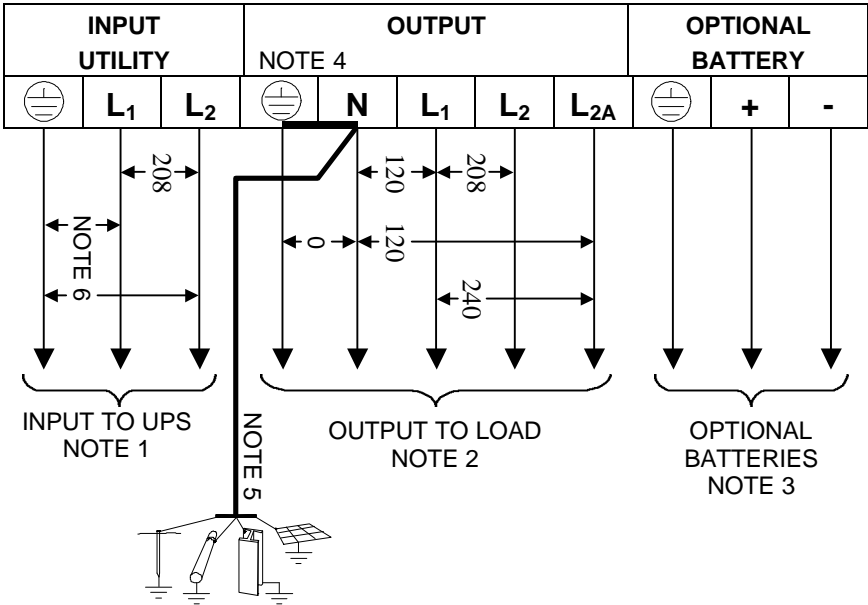

Grounding Electrode System  
or Protective Earth System

## NOTES FOR GXT6000T / 10000T - 208X UPS ONLY

1. The installer must provide circuit breaker protection according to local codes. The utility disconnect must be within sight of the UPS. Maintain service space around the UPS or use flexible conduit.
2. The installer must provide output distribution panels, circuit breaker protection, or emergency disconnect switches according to local codes. Output circuits must not share a common conduit with input circuits or any other wiring. IMPORTANT - Distribute any 120VAC loads evenly between L1 AND L2A. Do not connect loads between the output terminals L2-N or L2-L2A. These are not standard voltages.
3. Refer to the manual provided with any optional battery cabinets.
4. The single-phase isolating output transformer is a separately derived source. The output neutral is already bonded to ground on the output terminals with a Bonding Jumper. No other bonding wire is needed. (see NEC 250-5d, 250-26, 250.91, 250.92)
5. Install an 8 AWG (10 mm<sup>2</sup>) (75° C copper wire) (minimum size, see NEC 250-5d, 250-81, 250-83, table 250-94) grounding electrode conductor between the grounded circuit conductor (neutral) and the nearest effectively grounded metal structural member, nearest effectively grounded metal water pipe, or other grounding electrode in the grounding electrode system. If the grounding electrode conductor must be protected, non-metal conduit is recommended. If metal conduit must be used, bond both ends of the conduit to the grounding electrode conductor. Conduit is not an acceptable grounding electrode conductor.
6. The utility may be derived from a single-phase or three-phase source. The line to ground voltages are dependant upon the grounding of the utility and do not affect the output voltages. Do not use a floating AC source.

# GXT6000T / 10000T - 240X ONLY

Models whose part number ends with a “240X” are fitted with a single-phase isolating output transformer and are separately derived sources. The output neutral is already bonded to ground on the output terminals with a Bonding Jumper (see NEC 250-5d, 250-26, 250.91, 250.92). The output L1 and L2 terminals are not connected to the input L1 and L2.

## GXT6000T-240X CONNECTIONS

CONNECTION	CURRENT RATING	Recommended Wire Size	Recommended External Overcurrent Protection
INPUT	27 AMPS	8 AWG (10 mm <sup>2</sup> )	40 AMPS
OUTPUT @ 230V	25 AMPS	8 AWG (10 mm <sup>2</sup> )	
OUTPUT @ 120V	50 AMPS	8 AWG (10 mm <sup>2</sup> )	
BATTERY	27 AMPS	8 AWG (10 mm <sup>2</sup> )	

SIZE GROUNDING (PROTECTIVE EARTH) CONDUCTORS EQUAL TO CIRCUIT CONDUCTORS

## GXT10000T-240X CONNECTIONS

CONNECTION	CURRENT RATING	Recommended Wire Size	Recommended External Overcurrent Protection
INPUT	44 AMPS	6AWG (16 mm <sup>2</sup> )	60 AMPS
OUTPUT @ 230V	42 AMPS	6AWG (16 mm <sup>2</sup> )	
OUTPUT @ 120V	83 AMPS	6AWG (16 mm <sup>2</sup> )	
BATTERY	44 AMPS	6AWG (16 mm <sup>2</sup> )	

SIZE GROUNDING (PROTECTIVE EARTH) CONDUCTORS EQUAL TO CIRCUIT CONDUCTORS

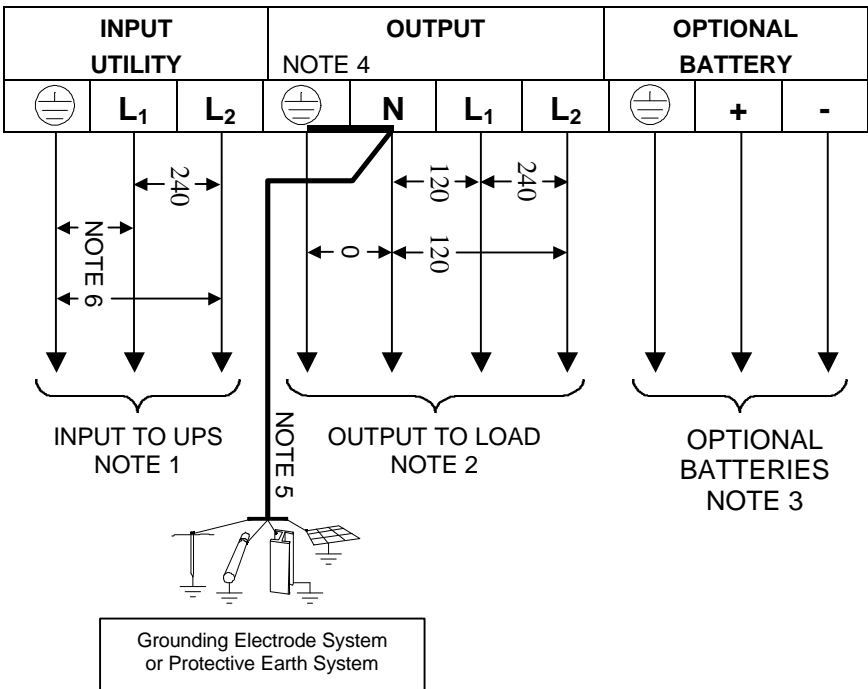

## **NOTES FOR GXT6000T / 10000T - 240X ONLY**

1. The installer must provide circuit breaker protection according to local codes. Maintain service space around the UPS or use flexible conduit.
2. The installer must provide output distribution panels, circuit breaker protection, or emergency disconnect switches according to local codes. Output circuits must not share a common conduit with input circuits or any other wiring. **IMPORTANT** - Distribute any 120VAC loads evenly between L1 AND L2.
3. Refer to the manual provided with any optional battery cabinets.
4. The single-phase isolating output transformer is a separately derived source. The output neutral is already bonded to ground on the output terminals with a Bonding Jumper. (see NEC 250-5d, 250-26, 250.91, 250.92)
5. Install an 8 AWG (10 mm<sup>2</sup>) (75° C copper wire) (minimum size, see NEC 250-5d, 250-81, 250-83, table 250-94) grounding electrode conductor between the grounded circuit conductor (neutral) and the nearest effectively grounded metal structural member, nearest effectively grounded metal water pipe, or other grounding electrode in the grounding electrode system. If the grounding electrode conductor must be protected, non-metal conduit is recommended. If metal conduit must be used, bond both ends of the conduit to the grounding electrode conductor. Conduit is not an acceptable grounding electrode conductor.
6. The utility may be derived from a single-phase or three-phase source. The line to ground voltages are dependant upon the grounding of the utility and do not affect the output voltages. Do not use a floating AC source.

## STABILIZERS / LEVELING FEET

When the UPS is located in its final position before or after wiring, it is necessary to fit stabilizer brackets and, if necessary, adjust the leveling feet. If the UPS is wired using a rigid wiring system, then movement of the UPS must be prevented by winding down the 4 leveling feet under the UPS as shown below. For UPS wired with flexible cables, this is optional. Note - Access to the leveling feet is obstructed by the stabilizer brackets, on the GXT10000 models.

Adjust the leveling feet as necessary using a 12mm open ended spanner/wrench. **DO NOT LOOSEN THE LARGER NUT ABOVE, AS THIS FIXES THE LEVELING FEET TO THE CHASSIS**

Attach the stabilizing brackets as follows.

GXT6000 models:

1. Using a Phillips-head screwdriver, remove the screws(4) from each of the bottom corners of the side panels.
2. Attach the stabilizing brackets to each corner using screws just removed.

GXT10000 models:

1. Using a Phillips-head screwdriver, remove the three inner-most screws at the base of both side panels.
2. Attach the stabilizers fixing with the screws just removed.

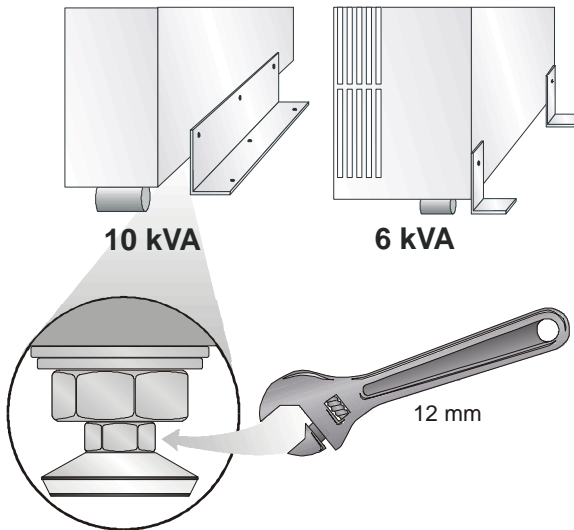

**Leveling Feet Adjustment Diagram**



## FERRITE BEAD INSTALLATION

When using either of the options below, to reduce the risk of radio interference, fit the ferrite assemblies supplied with the UPS as follows:

### Serial Communications

Attach the smaller enclosed ferrite bead clamp to the communication cable as shown in the drawing using the following directions:

- Open the ferrite bead.
- Place the communication cable inside the ferrite bead groove.
- Position the ferrite beads as close as possible to the end of the cable that connects to the DB9 connector of the UPS.
- Close the ferrite bead so that the ferrite bead's case snaps closed with the cable routed inside the ferrite bead's case.

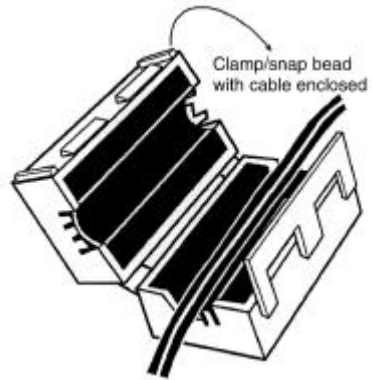

### SNMP Installation ( When fitted)

Attach the larger enclosed ferrite bead clamp to the network cable as shown in the drawing using the following directions:

- Open the ferrite bead.
- Place the network cable inside the ferrite bead groove.
- Wrap the cable once around the bead.
- Position the ferrite cable as close as possible to the end of the cable that connects to the UPS.
- Close the ferrite bead so that the ferrite bead's case snaps closed with the cable routed inside the ferrite bead's case.

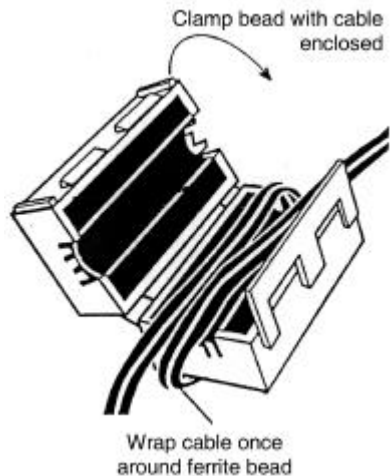

## COMMISSIONING THE UPS

### Output Voltage Selector Switches

The Output Voltage Selector Switches, located on the rear of the UPS, are designed to allow selecting or changing the desired output voltage to match the utility. The settings to choose from are 208, 220, 230 and 240 VAC output.

240X Units	
208 / 104	↑↑ - both switches up
220 / 110	↑↓ - first switch up, second down
230 / 115	↓↓ - both switches down
240 / 120	↓↑ - first switch down, second up (Factory Default)
208X Units	
Output voltage will be 208/120 regardless of switch position.	
208 Units	
208 V	↑↑ - both switches up (Factory Default)
220 V	↑↓ - first switch up, second down
230 V	↓↓ - both switches down
240 V	↓↑ - first switch down, second up

**NOTE:** NEVER change the switch settings while UPS is on and powering connected loads.

**NOTE:** Setting output voltage to 208 VAC will cause UPS unit to be derated to 90% of the VA and Watt rating listed in specification section.

1. Adjust the output voltage switch settings to the desired value.
2. Follow the instructions for Powering up the UPS referenced earlier in this manual. Sequence through the operating modes, using the front panel pushbuttons, in accordance with operating instructions to check functionality of the UPS.
3. Set the UPS to NORMAL MODE OPERATION- UPS mode. Check on the output terminals of the UPS, for the correct output voltage for the voltage rating of the intended loads.
4. In NORMAL MODE OPERATION- UPS mode, power up customers load and check that it is within the UPS rating by observing the front panel LED's
5. In UPS mode, press the UPS ON/ALARM /BATTERY TEST pushbutton to carry out battery test and ensure the load can be supported. Note - Full battery capacity will not be available until a battery recharge cycle has been completed.

The UPS is now ready for service. In case of problems refer to the fault finding section or call your local distributor for advice.

# CONTROLS AND INDICATORS

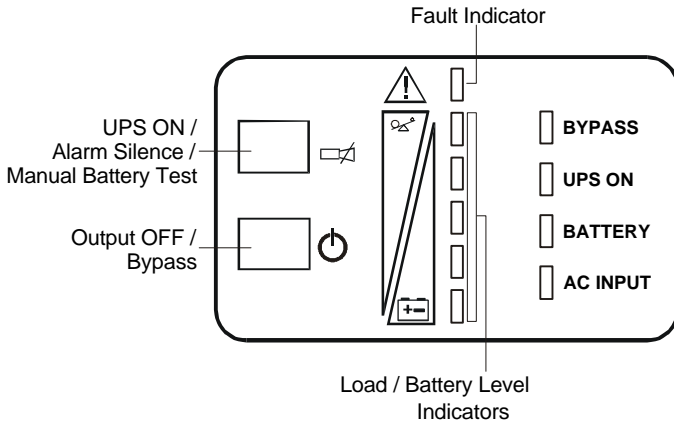

## **Fault Indicator (Red)**

The Fault indicator is illuminated if the UPS has detected a problem. Also, one or more of the load/battery level indicators may be illuminated (refer to Troubleshooting Guide).

## **BYPASS Indicator (Amber)**

The BYPASS indicator is illuminated when the UPS is operating from BYPASS power. An alarm will sound indicating the UPS is powering the load through the BYPASS.

## **UPS ON Indicator (Green)**

The UPS On indicator is illuminated when the UPS inverter is operating and supplying power to your connected loads.

## **Battery Indicator (Amber)**

The Battery indicator is illuminated when the UPS is operating from the battery system. An alarm will sound indicating the UPS is powered from batteries.

## **AC Input Indicator (Green)**

The AC Input indicator is illuminated when utility power is available and within the PFC input specification.

### **Load/Battery Level Indicators (4 Green, 1 Amber)**

The Load/Battery Level indicators have dual functions. During NORMAL mode operation LED indicators display the approximate electrical load placed upon the UPS; and during battery mode operation LED indicators display approximate battery capacity.

The UPStation GXT is equipped with automatic and remote battery test features. The automatic test occurs every 14 days if a manual battery test has not been performed or if utility has not been interrupted (14 day timer resets if unit goes to battery). Should the battery fail this test, the fault indicator along with the A and C diagnostic LEDs will illuminate and an alarm will sound (refer to Troubleshooting Guide). The remote test feature functions with either SiteNet® 2 or SiteNet® SNMP Manager software and can remotely initiate the battery test.

### **UPS ON/Alarm Silence/Manual Battery Test Button**

This button controls output power to connected load(s) and has three functions: UPS ON, Alarm Silence, and Manual Battery Test. To start the UPS, while in the BYPASS mode, press the ON button until the command is acknowledged by a beep from the audible alarm. This will provide conditioned and protected power into the output terminal block.

To silence alarms; press the ON button for at least one half second while alarm conditions are present. After the alarm is silenced, the UPStation GXT will reactivate the alarm system to alert of additional problems.

**NOTE:** The low battery and BYPASS reminder alarms cannot be silenced.

**BATTERY TESTING** - To initiate a manual battery test, press the ON button for at least one half second while operating in normal UPS mode power and no alarm conditions are present. If the bottom two LED's do not illuminate during a Battery Test, allow the UPS to recharge the batteries for 24 hours. After 24 hours, retest the batteries. If the batteries have been re-tested and the bottom two LED's still do not illuminate, contact your dealer or Technical Support for a battery replacement.

### **OUTPUT OFF/BYPASS Button**

This button controls output power to connected load(s) and has dual functions: OUTPUT OFF and BYPASS.

**CAUTION:** Pressing the OUTPUT OFF/BYPASS button once during normal operation will cause the load to be transferred to BYPASS power if BYPASS voltage is within +/- 17% of nominal. If the BYPASS voltage is outside this range, transfer to BYPASS power will not be permitted to protect the connected load. Pressing this button a second time within 4 seconds will result in loss of power to the output and connected loads in all cases. Perform all necessary shutdown procedures on connected loads before pressing this button.

# GXT 6 & 10 kVA Component Diagram 208 Models Shown

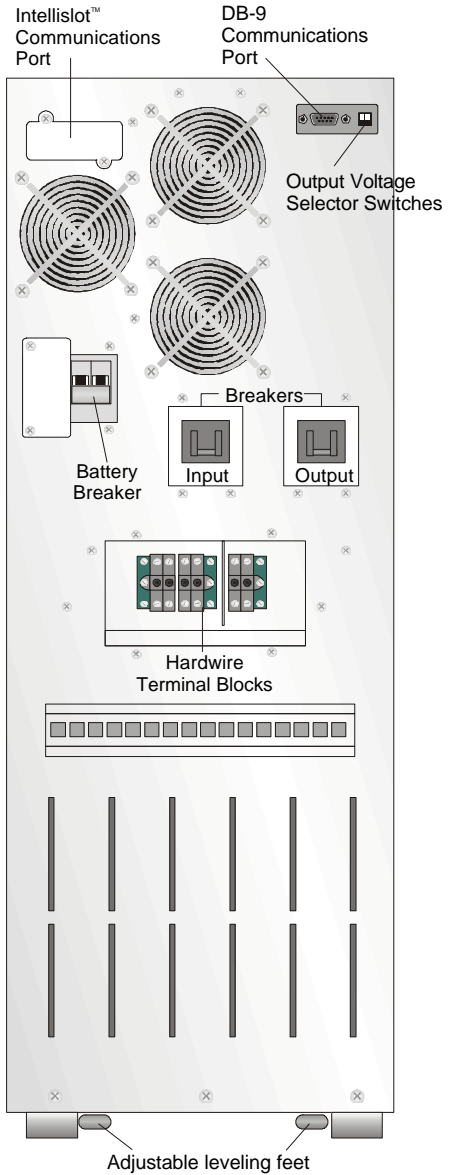
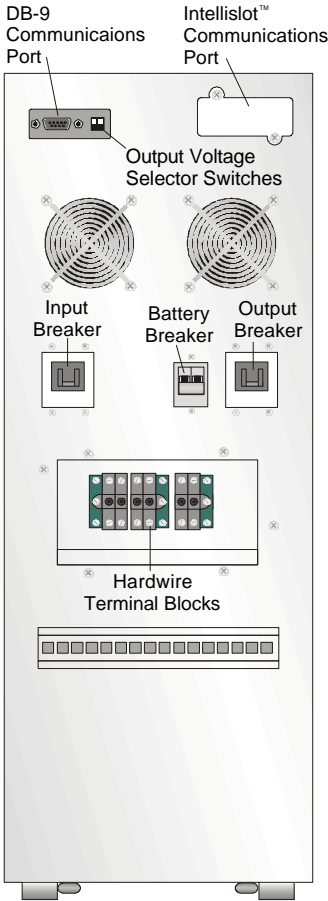

# OPERATING MODES

## NORMAL MODE OPERATION- UPS mode

During normal operation, utility power provides energy to the UPS. The filters, the power factor correction circuit and the inverter process this power to provide computer grade power to connected loads. The UPS maintains the batteries in a fully charged state.

The four green Leads indicate an approximate level of load in 25% increments. If the UPS becomes loaded beyond full rating, the fifth (amber) LED indicator will illuminate and sound an alarm.

The display template indicates the percentage of load on the UPS output.

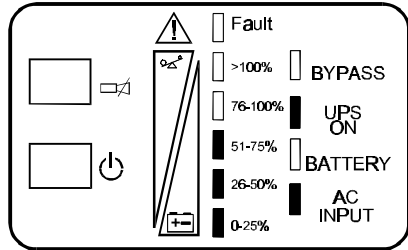

*Normal Mode Operation at 51-75% loading*

## BATTERY MODE OPERATION

Battery mode occurs in event of an extreme input voltage condition or complete utility failure. The battery system supplies power through the Rectifier / PFC to the inverter to generate power for the connected load.

During battery mode the AC Input LED will extinguish, and the Battery LED will illuminate to warn that a utility problem has occurred. An alarm will sound every 10 seconds. This will change to 2 beeps every 5 seconds when battery runs low (approximately 2 minutes remaining). Each load/battery level indicator represents a 20% capacity level. As capacity decreases, fewer indicators remain illuminated. Refer to the Troubleshooting Guide.

To increase this time, turn off non-essential pieces of equipment (such as idle computers and monitors) or add optional external battery cabinets.

**CAUTION:** Turning off the UPS while in battery mode will result in loss of output power.

Once utility power is restored, the UPS resumes normal operation. At this time, the Battery Charger begins recharging the battery.

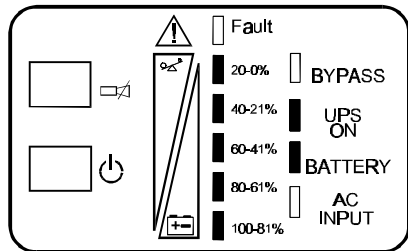

*Battery Mode Operation at 81-100% battery capacity*

## BYPASS MODE OPERATION

During BYPASS operation, utility power provides energy to your load and maintains the batteries in a fully charged state. The BYPASS will automatically power the load temporarily during overloads of the inverter, when diagnostics detect equipment problems, or when the operator selects BYPASS operation.

The four green LEDs indicate an approximate level of load in 25% increments. If the BYPASS becomes loaded beyond full rating, the fifth (amber) LED indicator will illuminate and sound an alarm.

The display template indicates the percentage of load on the output.

**CAUTION:** The BYPASS power path does not protect the connected equipment from severe disturbances on the utility supply.

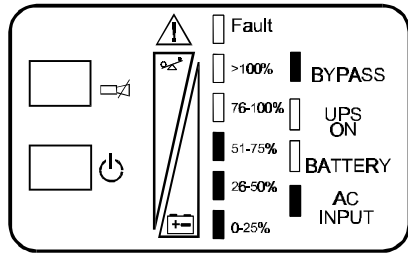

*Bypass Mode Operation at  
51-75% loading*

## OUTPUT OFF MODE OPERATION

The UPS output may be disabled even when utility or batteries are available. Output power may be enabled or disabled using both the front panel controls or communication options. The UPS output may be disabled automatically when the utility is absent for an extended time and batteries have been discharged. Output power will be restored automatically upon restoration of utility.

When the UPS is standing by in this mode with the utility power absent, all panel LEDs and cooling fans will turn off.

**CAUTION:** The UPS and loads are not isolated from hazardous voltages in this mode and output power could be restored at any time. Follow instructions for powering down the UPS and fully isolating the equipment for maintenance.

## MANUAL OPERATION WITH UTILITY AVAILABLE

Under normal circumstances, the UPS will be operated with utility available. The UPS can operate in three possible modes with utility available:

**NORMAL MODE OPERATION** - **UPS ON** LED will be on and the inverter will provide power to the load.

**BYPASS MODE OPERATION** - **BYPASS** LED will be on and the bypass will provide power to the load directly from the utility.

**OUTPUT OFF MODE OPERATION** - **UPS ON** and **BYPASS** LEDs will be off and the load will not have power. **AC LINE** LED will be on and batteries will recharge.

## STARTING THE UPS WITH UTILITY AVAILABLE

1. Ensure the load equipment is turned off, and all loads are properly connected to the UPS output.
2. Verify that the utility supplying the UPS is turned on by closing any circuit breaker or switch on the supply side of the UPS.
3. Turn On (Close) the BATTERY circuit breaker.
4. Turn ON (Close) the INPUT and OUTPUT circuit breakers. After a start-up sequence, the **AC INPUT** LED should be on. If this LED is not on, verify that the utility is turned on to the UPS from any external distribution panel or isolating switch.
5. After about 10 seconds, the UPS will automatically default to **BYPASS MODE OPERATION**. The **BYPASS** LED should be on. The load will now receive power, but is not protected from disturbances in the utility.
6. Press the **UPS ON/ALARM/BATTERY TEST** button for at least one second until you hear the audible alarm "beep" to signal acceptance of the command. After a delay of about 10 seconds, the **BYPASS** LED will extinguish, and the **UPS ON** LED should light. The UPS will then initiate a self-test and battery test. When these tests are complete, the UPS is ready for **NORMAL UPS OPERATION**.
7. Confirm that the **UPS ON** and **AC INPUT** LEDs are on and the **BATTERY** and **BYPASS** LEDs are off.
8. Connected load equipment may now be turned on.



## **POWERING DOWN THE UPS WITH UTILITY AVAILABLE**

1. Shutdown all connected load equipment.
2. Press the **OUTPUT OFF/BYPASS** button once until a "beep" is heard. The **UPS ON LED** will extinguish and the **BYPASS LED** will light if the **BYPASS** voltage is within an acceptable range. The load is now powered through the **BYPASS** and there is no **UPS** protection. The **UPS** will remain in **BYPASS MODE OPERATION** until the user continues with the next step to turn the **UPS** off.
3. Press the **OUTPUT OFF/BYPASS** button for at least 1 second, twice, within a 4 second time interval. The **BYPASS LED** will extinguish and all power to the load will stop. The **UPS** is in **OUTPUT OFF MODE OPERATION** and the **AC LINE LED** will be on.
4. To isolate the **UPS**, turn off the **INPUT**, **OUTPUT**, and **BATTERY** breakers on the rear of the **UPS**. For complete isolation, turn off the utility to the **UPS**.

## **ALTERNATE QUICK POWERING DOWN THE UPS**

The **UPS** will skip past **BYPASS MODE OPERATION** directly to **OUTPUT OFF MODE OPERATION** even with utility available.

1. Shutdown all connected load equipment.
2. Press the **OUTPUT OFF/BYPASS** button for at least 1 second, twice, within a 4 second time interval. The **UPS ON LED** will extinguish and the **BYPASS LED** will light for a short period then extinguish and all power to the load will stop. The **UPS** is in **OUTPUT OFF MODE OPERATION** and the **AC LINE LED** will be on.
3. To isolate the **UPS**, turn off the **INPUT**, **OUTPUT**, and **BATTERY** breakers on the rear of the **UPS**. For complete isolation, turn off the utility to the **UPS**.

**NOTE:** Pressing the **OUTPUT OFF/BYPASS** button will always remove the load from **UPS** power protection. Pressing the **OUTPUT OFF/ BYPASS** button for at least 1 second, twice, within a 4 second time interval will always remove power from the load.

## **MANUAL OPERATION WITHOUT UTILITY**

The **UPS** operating time is limited by available battery power without utility. The **UPS** may be manually turned off after the loads have been turned off to prevent the batteries from being completely drained. It may also be desirable to power up the loads for a short time without utility power to support a critical operation.

With utility unavailable, the **UPS** has two possible modes:

**BATTERY MODE OPERATION** - **UPS ON** and **BATTERY** LEDs will be on and the inverter will provide power to the load using battery power.

**OUTPUT OFF MODE OPERATION** – All LED's will be off and the load will not have power.

## **POWERING UP THE UPS WITHOUT UTILITY**

1. Ensure the load equipment is turned off, and all loads are properly connected to the UPS output.
2. Verify that the **BATTERY, INPUT, AND OUTPUT** circuit breakers remain closed.
3. Press the **UPS ON/ALARM/BATTERY TEST** button for at least one second until you hear the audible alarm emit a "double beep" to signal acceptance of the command. After a short delay, the **BATTERY** LED should light. The UPS will then initiate a self-test and approximately 10 seconds after these tests are completed, the **UPS ON** and **BATTERY** LEDs will light indicating that the batteries now power the load.
4. Connected loads may now be started. If the utility is not restored before the batteries are fully discharged, the UPS will automatically turn off all power to the load.

**NOTE:** Closely monitor remaining stored energy using the battery capacity LEDs or communication option. If an orderly shutdown of the load is required, it must be completed before the batteries are fully discharged.

## **POWERING DOWN THE UPS WITHOUT UTILITY**

1. Shutdown all connected load equipment.
2. Press the **OUTPUT OFF/BYPASS** button once until a "beep" is heard. The UPS will switch from **BATTERY MODE OPERATION** to **OUTPUT OFF MODE OPERATION**. All LEDs will turn off and all power to the load will stop.
3. To isolate the UPS, turn off the **INPUT, OUTPUT, and BATTERY** breakers on the rear of the UPS. For complete isolation, turn off the AC supply to the UPS.

**CAUTION:** When the UPS is in **OUTPUT OFF MODE OPERATION** without **UTILITY**, control panel LEDs and cooling fans will be off. The UPS is not disabled and output power could be restored at any time. Do not attempt to service the load or UPS without isolating the UPS.

## COMMUNICATIONS

### UPS MONITORING

The UPStation GXT UPS has the capability of being monitored with stand alone computers, network workstations, network servers, or UNIX hosts via the DB-9 socket located on the rear of the UPS.

This capability is used in applications requiring the UPS to provide status and power monitoring information to the computer system. For example, during a Utility power failure, the information can be used by the computer's operating system or application program to automatically save information in buffers, to close files, and shut down operations prior to battery capacity depletion.

Monitoring of the UPS via a computer is as easy as downloading SiteNet® MultiLink™ free from our web site ([www.liebert.com](http://www.liebert.com)). A MultiLink cable may also be built by following instructions provided on our web page. You may also purchase a Liebert SiteNet® 1 shutdown kit (sold separately). Consult your local Liebert representative to determine the correct software kit for your application. The kit includes shutdown software and a special purpose cable.

### UPS INTELLIGENT COMMUNICATIONS

The UPStation GXT UPS has the capability to communicate intelligently with stand alone computers, network workstations, network servers, or UNIX hosts via the DB-9 socket located at the rear of the UPS. By purchasing the optional Liebert SiteNet® 2 software package (sold separately), intelligent communications allows the following capabilities:

- Quantitative monitoring of Utility and UPS power
- Quantitative monitoring of internal UPS parameters
- Periodic tests of battery quality and replacement notification
- Timed and delayed shutdown of the UPS
- Logging of power disturbances and anomalies

Consult your local Liebert sales representative for more information about SiteNet® 2 software.

### UPS INTELLISLOT™ COMMUNICATIONS

The UPStation GXT UPS contains an Intellislot™ communications port for the optional internal MultiPort 4 card, AS400 card, or Ethernet SNMP card. Optional SiteNet® SNMP Manager software is available to allow communication through several network management systems to be used in conjunction with the Intellislot SNMP card. Contact your local Liebert representative, dealer, or reseller.

## COMMUNICATIONS INTERFACE PORT

The UPStation GXT UPS contains a standard DB-9 socket located on the rear of the UPS unit. Several signals are provided on this port and are assigned as follows:

PIN	ASSIGNMENT DESCRIPTION
1	Low Battery (open collector)
2	UPS TxD (typical RS-232 levels)
3	UPS RxD (typical RS-232 levels)
4	Remote Shutdown (5-12V); battery operation
5	Common
6	Remote Shutdown (short to pin 5); any mode
7	Low Battery (open emitter)
8	Utility Fail (open emitter)
9	Utility Fail (open collector)

**PIN ASSIGNMENT**

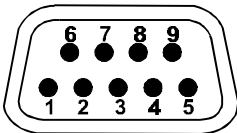

**COLLECTOR TO EMITTER\***

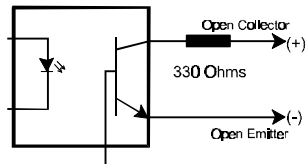

\*Maximum voltage and current on pins 1,7,8,9 is 80V DC; 10.0 mA.

**CAUTION:** TO MAINTAIN SAFETY (SELV-Safety Extra Low Voltage) BARRIERS AND FOR ELECTROMAGNETIC COMPATIBILITY, SIGNAL CABLES SHOULD BE SEGREGATED AND RUN SEPARATE FROM ALL OTHER POWER CABLES, BY 1inch (25mm) WHERE APPLICABLE.

## TROUBLESHOOTING

The information below indicates various symptoms a user may encounter in the event the UPStation GXT develops a problem. Use this information to determine whether external factors cause the problem and how to remedy the situation.

1. The fault indicator will illuminate indicating the UPS detected a problem.
2. An alarm will sound, alerting that the UPS requires attention.
3. One or more additional load/battery level LED indicators will be illuminated to provide a diagnostic aid to the operator, as described below:

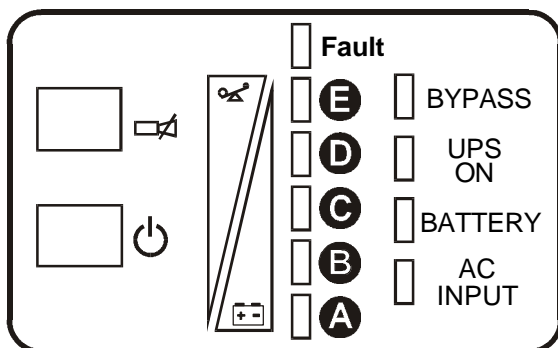

- |                 |   |
|-----------------|---|
| <b>All.</b>     | On bypass due to output overload (beep every half second)             |
| <b>A.</b>       | On bypass due to over temperature condition<br>(beep every 4 seconds) |
| <b>B.</b>       | On bypass due to DC bus over voltage (beep every 4 seconds)           |
| <b>D.</b>       | On bypass due to PFC failure (beep every 4 seconds)                   |
| <b>E.</b>       | On bypass due to inverter failure (beep every 4 seconds)              |
| <b>A&amp;C.</b> | UPS failed battery test (long beep every minute)                      |
| <b>C&amp;E.</b> | UPS shutdown due to command from communication port (SNMP); no beep   |

The fault indicators will be illuminated indefinitely while battery charger is operational, or for a maximum of 5 minutes while battery charger is not operational. If a problem persists consult your dealer, or contact Technical Support. World Wide Technical Support numbers are located at the end of this manual.

## AUDIBLE ALARM CONDITIONS

CONDITION	ALARM
Battery mode (utility failure)	One short beep every ten seconds
Low battery	Two short beeps every five seconds
Output overload (bypass)	One short beep every half second
Over temperature (bypass)	One second beep every four seconds
DC Bus over voltage (bypass)	One second beep every four seconds
PFC failure (bypass)	One second beep every four seconds
Inverter failure	One second beep every four seconds
Battery Test failure	Two second beep every minute

## TROUBLESHOOTING GUIDE

PROBLEM	CAUSE	SOLUTION
UPS fails to start when on button is pressed	UPS is short circuited or overloaded	Ensure UPS is off. Disconnect all loads and ensure nothing is lodged in output terminal block. Ensure loads are not defective or shorted internally.
	Internal fuse is blown, indicating internal fault	Do not attempt to open or service the UPS. Contact your dealer or technical support.
	Breaker not closed or has tripped.	Close breaker or remove overload.
Battery indicator is illuminated	UPS input not connected	UPS is operating from battery mode, make certain UPS is securely connected to source.
	UPS input protection has opened	UPS is operating from battery mode. Save data and close applications. Replace UPS input fuse or reset input breaker, then restart UPS.
	Utility voltage out of UPS input range.	UPS is operating from battery mode. Save data and close applications. Ensure Utility supply voltage is within acceptable limits for UPS.
UPS has reduced battery time	Batteries not fully charged	Apply input voltage for at least 24 hrs to recharge batteries.
	UPS is overloaded	Check load level display and reduce load level
	Batteries may not be able to hold a full charge due to age	Replace batteries. Contact your dealer or technical support.

## TROUBLESHOOTING GUIDE

PROBLEM	CAUSE	SOLUTION
Fault indicators and all load level LED's are illuminated	UPS overloaded or load equipment is faulty	Check load level display and remove non-essential loads. Recalculate load VA and reduce number of loads connected to UPS. Check load equipment for faults.
Fault indicators and diagnostic LED A are illuminated	UPS internal fan has a problem or UPS shutdown due to temperature condition. Load is on bypass power.	Press Alarm silence button. Ensure that there are no obstructions in front panel vents or on rear panel fans; and UPS is not overloaded. Once the temperature is reduced, the UPS will restart and transfer the connected equipment to inverter power automatically.
Fault indicators and diagnostic LED B are illuminated	UPS internal DC bus over voltage	UPS requires service. Contact your dealer or technical support.
Fault indicators and diagnostic LED D are illuminated	UPS PFC fault.	UPS requires service. Contact your dealer or technical support.
Fault indicators and diagnostic LED E are illuminated	UPS inverter fault.	UPS requires service. Contact your dealer or technical support.
Fault indicators and diagnostic LED A & C are illuminated	UPS failed the battery test.	Replace batteries. Contact your dealer or technical support.
Fault indicators and diagnostic LED C & E are illuminated	UPS shutdown due to a command from the communications port(s)	Your UPS has received a signal or command from the attached computer. If this was inadvertent, ensure the communication cable used is correct for your system. For assistance, contact your dealer or technical support.

## MAINTENANCE

The UPStation GXT UPS requires very little maintenance. The batteries are valve regulated, nonspillable, lead acid, and should be kept charged to obtain their designed life. The UPS continuously charges the batteries when connected to the Utility supply.

When storing the UPS for any length of time, it is recommended to apply power to the UPS for at least 24 hours every four to six months to ensure full recharge of the batteries. In no case should the unit be stored in excess of six months without recharge. Periodically, examine the vents on the front and rear of the cabinet, and remove any obstructions from the surface of the vents.



## SPECIFICATIONS

MODEL NUMBER	GXT6000T-208	GXT10000T-208
MODEL RATING VA/W (max)	5400 / 3780	9000 / 6300
<b>DIMENSIONS: mm (in)</b>		
Unit W x D x H	260 x 555 x 803 (10.3 x 21.9 x 31.6)	340 x 650 x 960 (13.4 x 25.6 x 37.8)
Shipping W x D x H	400 x 850 x 1065 (15.8 x 33.5 x 41.9)	510 x 840 x 1235 (20.1 x 33.1 x 48.6)
<b>WEIGHT: kg (lbs)</b>		
Unit	99 (218)	187 (412)
Shipping	130 (288)	227 (500)
<b>INPUT AC PARAMETERS</b>		
Voltage Range (typical)	208 VAC nominal; variable based upon output load	
100% - 90% Loading	186 VAC to 280 VAC; ±5.0 VAC	
90% - 70% Loading	159 VAC to 280 VAC; ±5.0 VAC	
70% - 30% Loading	139 VAC to 280 VAC; ±5.0 VAC	
30% - 0% Loading	119 VAC to 280 VAC; ±5.0 VAC	
Frequency	46.6 – 52.4 Hz or 57.1 - 62.9 Hz; auto sensing	
Input connection	Hardwire terminal block	
<b>OUTPUT AC PARAMETERS</b>		
Output connection	Hardwire terminal block	
Voltage	208/220/230/240 VAC; ±3%	
Frequency	50 Hz or 60 Hz; auto sensing	
Waveform	Sinewave	
Main Mode Overload	200% for 8 cycles; 130% for 10 seconds, then transfer to bypass	
<b>BATTERY PARAMETERS</b>		
Type	Valve-regulated, nonspillable, lead acid	
Qty. x Voltage x Rating	20 x 12V x 7.0 Ah	40 x 12V x 7.0 Ah
Back-up Time	7 min. minimum	10 min. minimum
<b>ENVIRONMENTAL</b>		
Operating Temperature	0° C to +40° C (+32° F to +104° F)	
Storage Temperature	-15° C to +50° C (+5° F to +122 °F)	
Relative Humidity	0% to 95%, non-condensing	
Operating Elevation	Up to 3000 m (10,000 ft.) at 40° C without derating	
Storage Elevation	15,000 m (50,000 ft.) maximum	
Audible Noise	<55 dB "A" at 1 meter	<65 dB "A" at 1 meter
<b>AGENCY</b>		
Safety	UL1778, Listed	
EMI/EMC	FCC Part 15, Class A	
Immunity	IEEE C62.41:1991	

# SPECIFICATIONS

<b>MODEL NUMBER</b>	GXT6000T-208X	GXT10000T-208X
<b>MODEL RATING VA/W (max)</b>	5400 / 3780	9000 / 6300
<b>DIMENSIONS: mm (in)</b>		
Unit W x D x H	260 x 555 x 803 (10.3 x 21.9 x 31.6)	340 x 650 x 960 (13.4 x 25.6 x 37.8)
Shipping W x D x H	400 x 850 x 1065 (15.8 x 33.5 x 41.9)	510 x 840 x 1235 (20.1 x 33.1 x 48.6)
<b>WEIGHT: kg (lbs)</b>		
Unit	142 (313)	247 (544)
Shipping	173 (381)	287 (633)
<b>INPUT AC PARAMETERS</b>		
Voltage Range (typical)	208 VAC nominal; variable based upon output load	
100% - 90% Loading	186 VAC to 280 VAC; $\pm 5.0$ VAC	
90% - 70% Loading	159 VAC to 280 VAC; $\pm 5.0$ VAC	
70% - 30% Loading	139 VAC to 280 VAC; $\pm 5.0$ VAC	
30% - 0% Loading	119 VAC to 280 VAC; $\pm 5.0$ VAC	
Frequency	46.6 – 52.4 Hz or 57.1 - 62.9 Hz; auto sensing	
Input connection	Hardwire terminal block	
<b>OUTPUT AC PARAMETERS</b>		
Output connection	Hardwire terminal block	
Voltage	208/120 VAC; $\pm 7\%$	
Frequency	50 Hz or 60 Hz; auto sensing	
Waveform	Sinewave	
Main Mode Overload	200% for 8 cycles; 130% for 10 seconds, then transfer to bypass	
<b>BATTERY PARAMETERS</b>		
Type	Valve-regulated, nonspillable, lead acid	
Qty. x Voltage x Rating	20 x 12V x 7.0 Ah	40 x 12V x 7.0 Ah
Back-up Time	7 min. minimum	10 min. minimum
<b>ENVIRONMENTAL</b>		
Operating Temperature	0° C to +40° C (+32° F to +104° F)	
Storage Temperature	-15° C to +50° C (+5° F to +122 °F)	
Relative Humidity	0% to 95%, non-condensing	
Operating Elevation	Up to 3000 m (10,000 ft.) at 40° C without derating	
Storage Elevation	15,000 m (50,000 ft.) maximum	
Audible Noise	<55 dB "A" at 1 meter	<65 dB "A" at 1 meter
<b>AGENCY</b>		
Safety	UL1778, Listed	
EMI/EMC	FCC Part 15, Class A	
Immunity	IEEE C62.41:1991	

## SPECIFICATIONS

<b>MODEL NUMBER</b>	GXT6000T-240X	GXT10000T-240X
<b>MODEL RATING VA/W (max)</b>	6000 / 4200	10000 / 7000
<b>DIMENSIONS: mm (in)</b>		
Unit	260 x 555 x 803	340 x 650 x 960
W x D x H	(10.3 x 21.9 x 31.6)	(13.4 x 25.6 x 37.8)
Shipping	400 x 850 x 1065	510 x 840 x 1235
W x D x H	(15.8 x 33.5 x 41.9)	(20.1 x 33.1 x 48.6)
<b>WEIGHT: kg (lbs)</b>		
Unit	139 (306)	244 (538)
Shipping	170 (374)	284 (626)
<b>INPUT AC PARAMETERS</b>		
Voltage Range (typical)	240 VAC nominal; variable based upon output load	
100% - 90% Loading	186 VAC to 280 VAC; $\pm 5.0$ VAC	
90% - 70% Loading	159 VAC to 280 VAC; $\pm 5.0$ VAC	
70% - 30% Loading	139 VAC to 280 VAC; $\pm 5.0$ VAC	
30% - 0% Loading	119 VAC to 280 VAC; $\pm 5.0$ VAC	
Frequency	46.6 – 52.4 Hz or 57.1 - 62.9 Hz; auto sensing	
Input connection	Hardwire terminal block	
<b>OUTPUT AC PARAMETERS</b>		
Output connection	Hardwire terminal block	
Voltage	208/104, 220/110, 230/115, 240/120 VAC (switch selectable); $\pm 7\%$	
Frequency	50 Hz or 60 Hz; auto sensing	
Waveform	Sinewave	
Main Mode Overload	200% for 8 cycles; 130% for 10 seconds, then transfer to bypass	
<b>BATTERY PARAMETERS</b>		
Type	Valve-regulated, nonspillable, lead acid	
Qty. x Voltage x Rating	20 x 12V x 7.0 Ah	40 x 12V x 7.0 Ah
Back-up Time	7 min. minimum	10 min. minimum
<b>ENVIRONMENTAL</b>		
Operating Temperature	0° C to +40° C (+32° F to +104° F)	
Storage Temperature	-15° C to +50° C (+5° F to +122 °F)	
Relative Humidity	0% to 95%, non-condensing	
Operating Elevation	Up to 3000 m (10,000 ft.) at 40° C without derating	
Storage Elevation	15,000 m (50,000 ft.) maximum	
Audible Noise	<55 dB "A" at 1 meter	<65 dB "A" at 1 meter
<b>AGENCY</b>		
Safety	UL 1778; Listed	
EMI/EMC	FCC Part 15 Class A	
Immunity	IEEE C62.41:199	

## LIMITED WARRANTY

Liebert Corporation extends the following LIMITED WARRANTY to the purchaser and to its customer (collectively referred to as the "Purchaser"); the enclosed Uninterruptible Power System (UPS) and components are free from defects in materials and workmanship under normal use, service, and maintenance FOR A PERIOD OF TWO YEARS FROM THE DATE OF ORIGINAL PURCHASE from Liebert or the Liebert dealer or retailer. THE FOREGOING WARRANTY IS THE ONLY WARRANTY GIVEN AND NO OTHER WARRANTY IS PROVIDED, EXPRESS OR IMPLIED, INCLUDING WITHOUT LIMITATION, MERCHANTABILITY OR FITNESS FOR A PARTICULAR PURPOSE. Certain aspects of disclaimers are not applicable to consumer products acquired by individuals and used for personal, family, or household purposes (as distinguished from industrial or other purposes). Local laws may not allow limitations on how long an implied warranty lasts, so the above limitation may not apply to you. This warranty gives you specific legal rights, and you may have other rights which vary according to local law.

Certain repairs or services are the responsibility of the Purchaser and the Purchaser is expected to pay for them. This warranty does not extend either to products with removed or altered serial numbers or to any losses or damages due to act of God or source external to the product, misuse, accident, abuse, neglect, negligence, unauthorised modification, alteration, or repair, use beyond rated capacity, or improper installation, maintenance, application or use, including, without limitation, use in a manner contrary to the accompanying instructions or applicable codes. WARNING: Warranty is void if the battery is allowed to discharge below the minimum battery cut-off point. The battery must be recharged every four (4) to six (6) months when not in use.

If the UPS fails to conform with the above warranty within the two year warranty period, Liebert will repair or replace the UPS, at Liebert's option. Repairs or replacements are warranted for the remainder of the original warranty period. Purchaser, to make a warranty claim, should call to obtain a Returned Goods Authorisation number and shipping instructions. Return transportation costs to Liebert are the responsibility of the Purchaser.

### "LIFE SUPPORT" APPLICATIONS

Due to the diversity of applications and considerations to be applied in each case, Liebert does not recommend or knowingly sells its products for such use.

The responsibility for risk assessment and management in applications where the malfunction or failure of the UPS could be reasonably expected to give rise to a risk of human life shall be the sole responsibility of the purchaser. Liebert accepts no liability for consequential harm in such applications.



## UPStation GXT™

**6 & 10 kVA  
208V & 240V**

### Technical Support

---

Global Services	1-800-LIEBERT
Applications U.S.A.	1-800-222-5877
Outside the U.S.A.	614-841-6755
U.K.	+44 (0) 1793 553355
France	+33 (0) 1 43 60 01 77
Germany	+49 89 99 19 220
Italy	+39 2 98250 1
Netherlands	+31 (0) 475 503333
E-mail	upstech@liebert.com
Web site	<a href="http://www.liebert.com">http://www.liebert.com</a>
Worldwide FAX tech support	+614-841-5471

#### The Company Behind The Products

With more than 500,000 installations around the globe, Liebert is the world leader in computer protection systems. Since its founding in 1965, Liebert has developed a complete range of support and protection systems for sensitive electronics:

- Environmental systems: close-control air conditioning from 1.5 to 60 tons.
- Power conditioning and UPS with power ranges from 250 VA to more than 1000 kVA.
- Integrated systems that provide both environmental and power protection in a single, flexible package.
- Monitoring and control — on-site or remote — from systems of any size or location
- Service and support, through more than 100 service centers around the world, and a 24-hour Customer Response Center.

While every precaution has been taken to ensure accuracy and completeness of this literature, Liebert Corporation assumes no responsibility, and disclaims all liability for damages resulting from use of this information or for any errors or omissions.

©1999 Liebert Corporation All rights reserved throughout the world. Specifications subject to change without notice.

® Liebert and the Liebert logo are registered trademarks of Liebert Corporation. All names referred to are trademarks or registered trademarks of their respective owners.

SL-23445 (12/99) Rev. 1