

# **GXT5000R-208**

**with GXT5VBATTW120 / GXT5VBATT Battery Cabinets**

**USER MANUAL**



**5000VA/3750W  
208 Volt**

**DISCONTINUED  
PRODUCT**

# TABLE OF CONTENTS

<b>IMPORTANT SAFETY INSTRUCTIONS</b> .....	<b>1</b>
<b>GLOSSARY OF SYMBOLS</b> .....	<b>3</b>
<b>INTRODUCTION AND SYSTEM DESCRIPTION</b> .....	<b>4</b>
<b>MAJOR COMPONENTS</b> .....	<b>5</b>
<b>Transient Voltage Surge Suppression (TVSS) &amp; EMI/RFI Filters</b> .....	<b>5</b>
<b>Rectifier/Power Factor Correction (PFC) Circuit</b> .....	<b>5</b>
<b>Inverter</b> .....	<b>5</b>
<b>Battery Charger</b> .....	<b>5</b>
<b>DC to DC Converter</b> .....	<b>5</b>
<b>Battery</b> .....	<b>5</b>
<b>Auxiliary 120V / 400VA Power</b> .....	<b>6</b>
<b>Dynamic Bypass</b> .....	<b>6</b>
<b>GENERAL DESCRIPTION</b> .....	<b>7</b>
<b>GENERAL INSTALLATION</b> .....	<b>9</b>
<b>CONTROLS AND INDICATORS</b> .....	<b>10</b>
<b>MODES OF OPERATION</b> .....	<b>12</b>
<b>Normal Mode Operation</b> .....	<b>12</b>
<b>Battery Mode Operation</b> .....	<b>12</b>
<b>Bypass Mode</b> .....	<b>13</b>
<b>Battery Recharge Mode</b> .....	<b>13</b>
<b>OPERATING INSTRUCTIONS</b> .....	<b>14</b>
<b>Turn On</b> .....	<b>14</b>
<b>Manual Bypass</b> .....	<b>14</b>
<b>Standby</b> .....	<b>14</b>
<b>OPTIONAL BATTERIES - PROGRAMMABLE RUN TIME</b> .....	<b>15</b>
<b>Programming the GXT5000R-208 for Battery Cabinet Count</b> .....	<b>15</b>
<b>Procedure to confirm the battery count</b> .....	<b>16</b>
<b>Procedure to change the battery count</b> .....	<b>16</b>
<b>COMMUNICATIONS</b> .....	<b>17</b>
<b>Relay Interface Card</b> .....	<b>17</b>
<b>Pin Configuration</b> .....	<b>17</b>
<b>EPO</b> .....	<b>18</b>
<b>SERIAL COMMUNICATIONS</b> .....	<b>19</b>
<b>Serial Cable</b> .....	<b>19</b>

<b>UPS COMMUNICATIONS WITH INTELLISLOT . . . . .</b>	<b>20</b>
<b>MAINTENANCE . . . . .</b>	<b>21</b>
<b>TROUBLESHOOTING . . . . .</b>	<b>22</b>
<b>SPECIFICATIONS . . . . .</b>	<b>24</b>
<b>BATTERY CABINET SPECIFICATIONS . . . . .</b>	<b>25</b>

## FIGURES

Figure 1	GXT5000R-208 UPS - Front view . . . . .	7
Figure 2	GXT5000R-208 UPS - Rear view . . . . .	7
Figure 3	GXT5VBATTW120 battery cabinet with auxiliary 120 VAC power - Rear view . . . . .	8
Figure 4	GXT5VBATT battery cabinet - Rear view . . . . .	8

## TABLES

Table 1	Pin configuration . . . . .	17
Table 2	LED indicators . . . . .	22
Table 3	Troubleshooting guide . . . . .	23

# IMPORTANT SAFETY INSTRUCTIONS



## WARNING

**OPENING OR REMOVING THE COVER MAY EXPOSE YOU TO LETHAL VOLTAGES WITHIN THIS UNIT EVEN WHEN IT IS APPARENTLY NOT OPERATING AND THE INPUT WIRING IS DISCONNECTED FROM THE ELECTRICAL SOURCE. OBSERVE ALL CAUTIONS AND WARNINGS IN THIS MANUAL. FAILURE TO DO SO MAY RESULT IN SERIOUS INJURY OR DEATH. REFER ALL UPS AND BATTERY SERVICE TO QUALIFIED SERVICE PERSONNEL. DO NOT ATTEMPT TO SERVICE THIS PRODUCT YOURSELF. NEVER WORK ALONE.**

## SAVE THESE INSTRUCTIONS

This manual contains important safety instructions. Read all safety, installation, and operating instructions before operating the Uninterruptible Power System (UPS). Adhere to all warnings on the unit and in this manual. Follow all operating and user instructions. Individuals without previous training can install and operate this equipment.

It is not intended for use with life support or other designated “critical” devices. Maximum load must not exceed that shown on the UPS rating label. The UPS is designed for data processing equipment. If uncertain, consult your local dealer or Liebert representative.

This UPS is designed for use on a properly grounded (earthed), 208VAC, 50Hz or 60Hz supply. Installation instructions and warning notices are located in the **Operating Instructions** section of this manual.

**ELECTROMAGNETIC COMPATIBILITY** - The GXT Series complies with the limits for a CLASS A DIGITAL DEVICE, PURSUANT TO Part 15 of FCC rules. Operation is subject to the following two conditions: (1) This device may not cause harmful interference, and (2) this device must accept any interference received, including interference that may cause undesired operation. Operating this device in a residential area is likely to cause harmful interference that users are responsible for correcting at their own expense.

Operate the UPS in an indoor environment only in an ambient temperature range of 32°F to +104°F (0°C to +40°C). Install unit in an environment free from conductive contaminants, moisture, flammable liquids, gases, or corrosive substances.

This UPS and BATTERY CABINETS contain no user serviceable parts. The UPS ON/Standby push buttons do not electrically isolate internal parts. Under no circumstances attempt to gain access internally due to risk of electric shock or burn. Do not continue to use the UPS if the front panel indications are not in accordance with these operating instructions, or the UPS performance alters in use. Refer all faults to your local dealer, Liebert representative or the Liebert Worldwide Support Group.

Never block or insert any object into the ventilation holes or other openings of the UPS.

DO NOT CONNECT equipment that could overload the UPS or demand DC current from the UPS, for example: electric drills, vacuum cleaners, laser printers, hair dryers or any appliance using half-wave rectification.

Storing magnetic media on top of the UPS may result in the possibility of data loss or corruption.

Turn the UPS off and disconnect AC and DC sources of power to the UPS before cleaning. Use only a soft cloth, never use liquid or aerosol cleaners. Keep the front and rear vents free of dust accumulation that could restrict airflow.

## SERVICE PERSONNEL INFORMATION

Servicing of batteries should be performed by qualified personnel knowledgeable about batteries and the required precautions. Keep unauthorized personnel away from the batteries. **PROPER DISPOSAL OF BATTERIES IS REQUIRED. REFER TO YOUR LOCAL LAWS AND REGULATIONS FOR BATTERY DISPOSAL REQUIREMENTS.**

When replacing batteries, replace with the same model of Liebert-authorized replacement batteries described in this manual (see **BATTERY PARAMETERS** in the **Battery Cabinet Specifications**).



### CAUTION

**Do not dispose of battery or batteries in a fire. The battery may explode.**



### CAUTION

**Do not open or mutilate the battery or batteries. Released electrolyte is harmful to skin and eyes. It may be toxic.**



### CAUTION

**A battery can present a risk of electrical shock and high short circuit current. The following precautions should be observed when working on batteries:**

- **Remove watches, rings, or other metal objects.**
- **Use tools with insulated handles.**
- **Wear rubber gloves and boots.**
- **Do not lay tools or metal parts on top of batteries.**
- **Disconnect charging source prior to connecting or disconnecting battery terminals.**

# GLOSSARY OF SYMBOLS



**Risk of electrical shock**



**Indicates caution followed by important instructions**



**Requests the user to consult the manual**

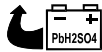

**Indicates the unit contains a valve-regulated lead acid battery**



**Recycle**



**DC voltage**



**Equipment grounding conductor**



**Bonded to ground**



**AC voltage**



**ON**



**Standby**

## INTRODUCTION AND SYSTEM DESCRIPTION

Congratulations on your choice of the Liebert GXT5000R-208 Uninterruptible Power System (UPS). It provides conditioned power to microcomputers and other sensitive electronic equipment.

Upon generation, AC power is clean and stable. However, during transmission and distribution it may be subject to voltage sags, spikes, or complete power failure that may interrupt computer operations, cause data loss, and even damage equipment. The GXT5000R-208 protects equipment from these disturbances.

The GXT5000R-208 has a nominal power rating of 5,000VA, 3,750 W. Complete model specifications appear at the end of this manual.

At least one external battery cabinet must be connected to the GXT5000R-208 to form a complete “on-line” UPS system. Two different models of battery cabinets are available:

- The GXT5VBATT provides batteries only.
- The GXT5VBATTW120 provides batteries and an auxiliary transformer to provide up to 400VA at 120V.

Both battery cabinets provide two battery connectors to allow the daisy-chain connection of additional battery cabinets. The UPS may be used with either battery cabinet, depending on whether the additional 120V / 400VA power supply is needed.

For applications requiring 120V, one GXT5VBATTW120 should be the first battery cabinet located adjacent to the GXT5000R-208. The GXT5000R-208 requires a one-foot interconnect cable to provide power to the internal 208V step-down transformer.

If more than one battery cabinet is desired for additional backup battery time, additional GXT5VBATTs can be added. Only one GXT5VBATTW120 external battery cabinet can be used per UPS system.

For ease of use, the GXT5000R-208 utilizes light emitting diode (LED) displays to indicate “load percentage” and “battery capacity,” and fault indications. It also provides a self-diagnostics test, a combination ON/Manual Battery Test button, a combination Standby/Manual Bypass button, and a variety of relay alarm contacts.



## MAJOR COMPONENTS

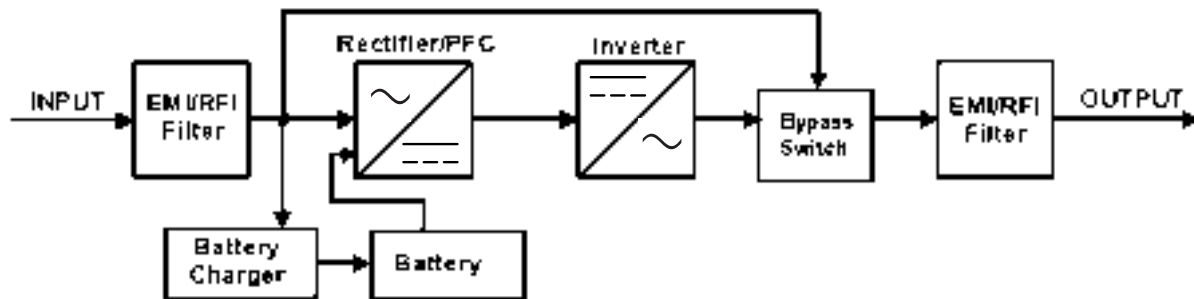

### Transient Voltage Surge Suppression (TVSS) & EMI/RFI Filters

These UPS components provide surge protection and filter both electromagnetic interference (EMI) and radio frequency interference (RFI). They minimize any surges or interference present in the utility line and keep sensitive equipment protected.

### Rectifier/Power Factor Correction (PFC) Circuit

In normal operation, the rectifier/PFC circuit converts utility AC power to regulated DC power for use by the inverter while ensuring that the waveshape of the input current used by the UPS is near ideal. Extracting this sinewave input current achieves two objectives: the utility power is used as efficiently as possible by the UPS, and the amount of distortion reflected on the utility is reduced. This results in cleaner power being available to other devices in the building not being protected by the GXT5000R-208.

### Inverter

In normal operation, the inverter utilizes the DC output of the power factor correction circuit and “inverts” it into precise, regulated sinewave AC power. When utility power fails, the inverter takes power from the battery through the DC to DC converter and inverts it into alternating current. In both modes of operation, the UPS inverter is on-line and continuously generating clean, precise, regulated AC output power.

### Battery Charger

The battery charger utilizes utility power and precisely regulates it to continuously “float” charge the battery system.

### DC to DC Converter

The DC to DC converter utilizes energy from the battery system and raises the DC voltage to the optimum operating voltage for the inverter. This allows the inverter to operate continuously at its optimum efficiency and voltage, thus increasing reliability.

### Battery

The GXT5VBATT and GXT5VBATTW120 employs valve-regulated, nonspillable, lead acid batteries. At an ambient temperature of 68°F to 77°F (20°C to 25°C) and with the UPS float charging, the battery design life will be maintained.

## Auxiliary 120V / 400VA Power

The GXT5VBATTW120 battery cabinet also provides a transformer to provide up to 400VA of 120V power.

## Dynamic Bypass

The GXT5000R-208 provides an alternate path for utility power to the connected load in the unlikely event of a UPS malfunction, such as overload, overtemperature, or an internal UPS failure. If a malfunction does occur, the UPS automatically transfers the connected load to bypass. Bypass operation is indicated by an alarm and illuminated Bypass LED (other LEDs also may be illuminated to indicate the diagnosed problem). To manually transfer the connected load from the inverter to bypass, press the Standby button  once.



### NOTE

*The bypass power path does NOT protect the connected equipment from disturbances on the utility supply, such as spikes, sags, and failure.*

# GENERAL DESCRIPTION

**Figure 1 GXT5000R-208 UPS - Front view**

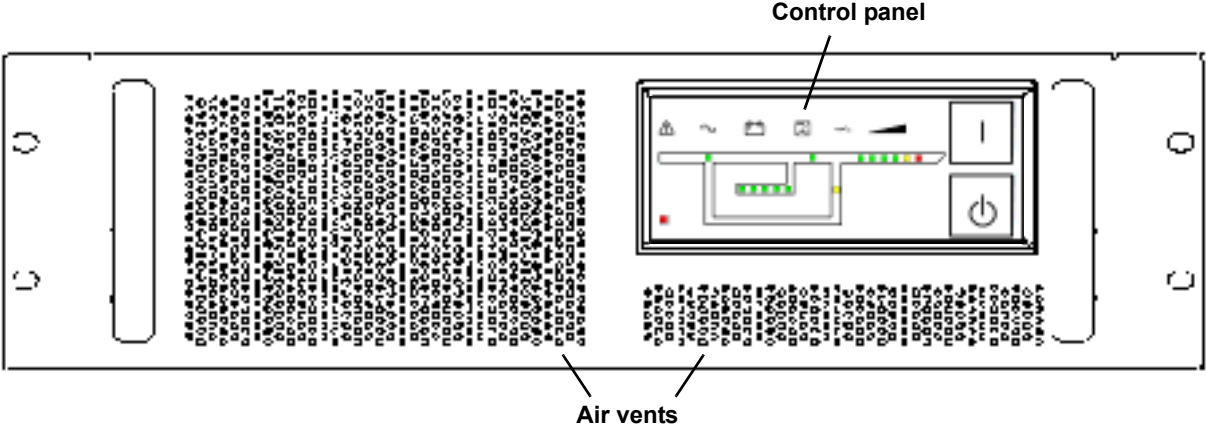

**Figure 2 GXT5000R-208 UPS - Rear view**

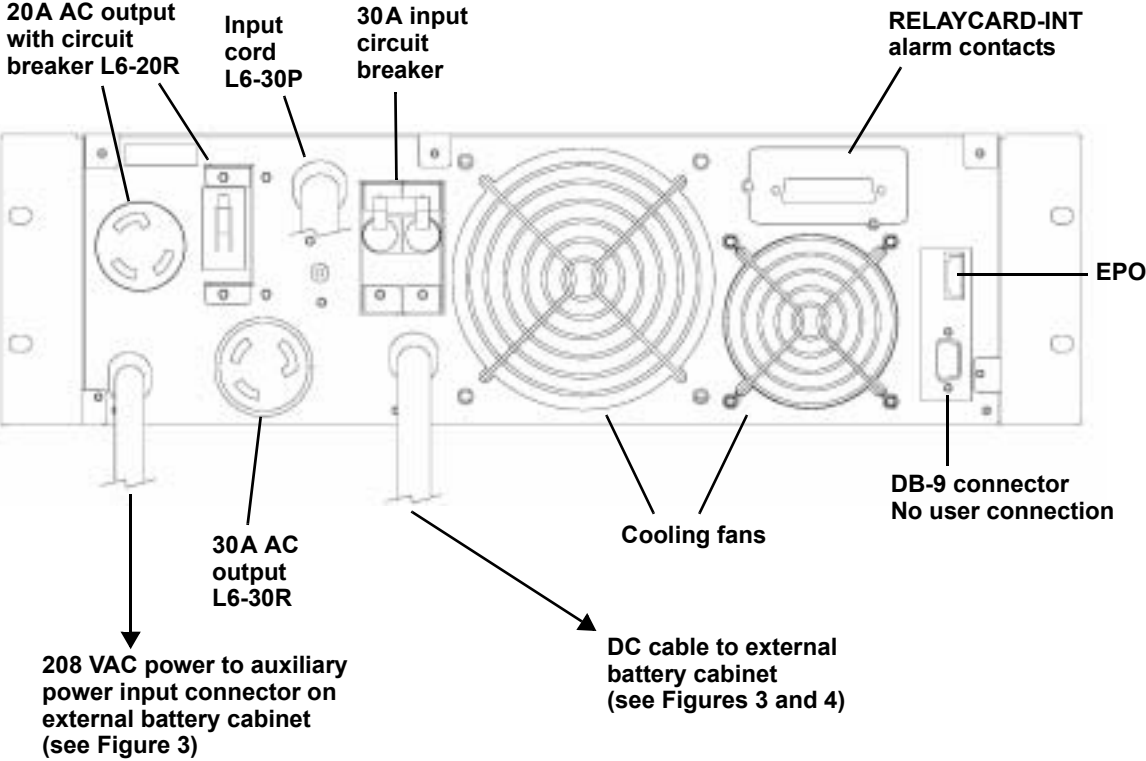

**Figure 3 GXT5VBATTW120 battery cabinet with auxiliary 120 VAC power - Rear view**

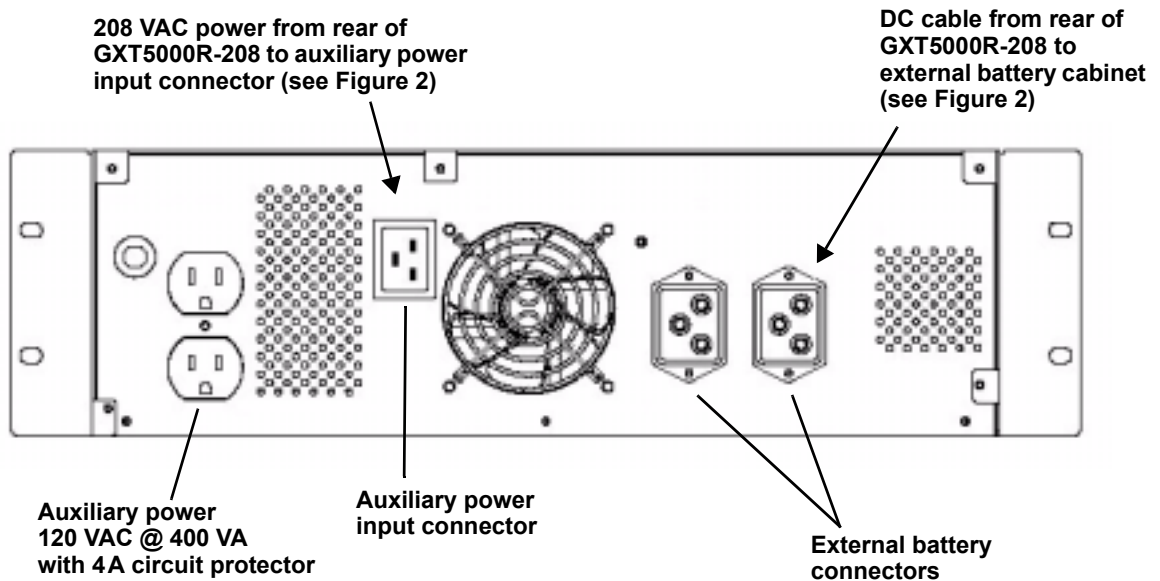

**Figure 4 GXT5VBATT battery cabinet - Rear view**

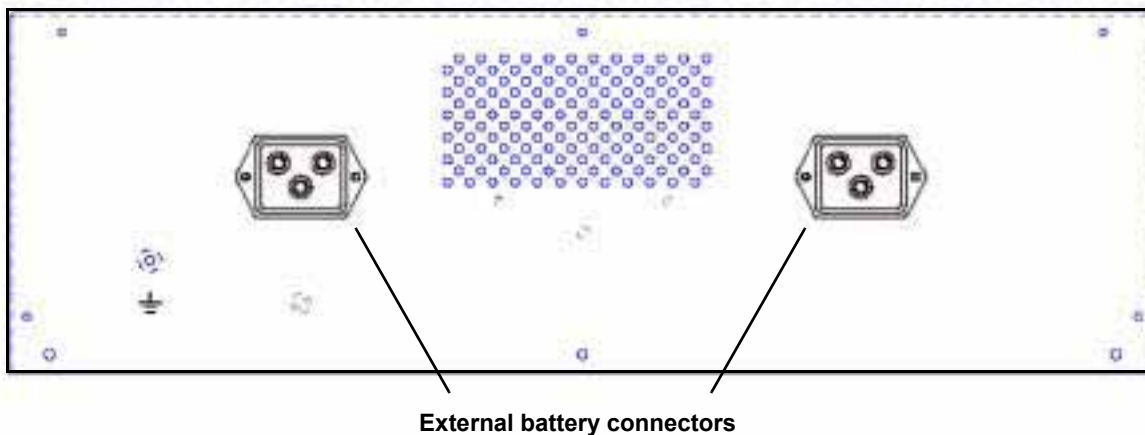

## GENERAL INSTALLATION

1. Verify that the 30A input circuit breaker on the GXT5000R-208 is in the OFF position.
2. **For GXT5VBATTW120 only** - Connect the 208V, one-foot-long cord, from the rear of the GXT5000R-208 to the mating external battery connector on the rear of the GXT5VBATTW120.
3. Connect the L6-20P from the load to the L6-20R on the rear of the GXT5000R-208. Turn on the 20A circuit breaker on the rear of the GXT5000R-208.
4. Verify that the EPO connector and jumper are in place.
5. Connect any 120V loads to the 5-15R receptacles on the rear of the GXT5VBATTW120, if used. Verify that the 4A circuit protector is not tripped.
6. Connect the DC cable from the GXT5000R-208 to the first battery cabinet. If additional battery cabinets are used, connect each battery cabinet to the next using the 18-inch battery cable supplied with each additional cabinet.
7. Connect the input cord to the nearest L6-30 branch circuit receptacle.

The UPS is now ready to turn on. Power will be applied to the load (bypass mode) immediately whenever the input 30A circuit breaker is initially closed. Please refer to the **Operating Instructions** section of this manual before turning on the input circuit breaker.

# CONTROLS AND INDICATORS

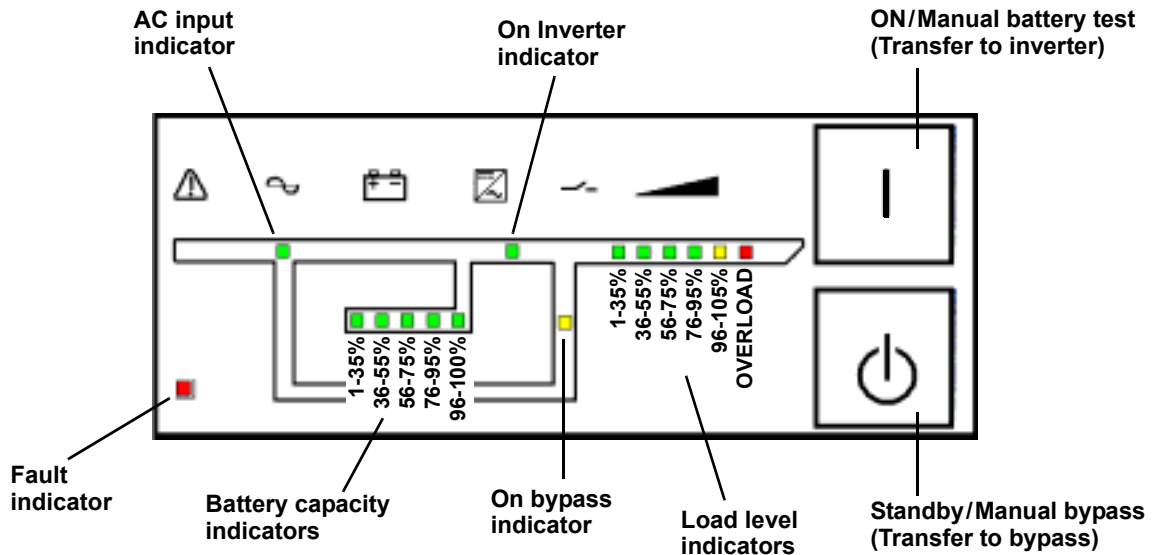

## ON/Manual Battery Test button

This button controls output power to connected load(s) and has two functions:

- Transfer load to inverter
- Manual battery test

Pressing the ON/Manual Battery Test button will transfer the load from bypass to inverter in order to provide conditioned and protected power to the output power receptacles. If the output is turned off using the Standby button , pressing the ON button will restart the load directly from the inverter.

To initiate a manual battery test, press the ON/Manual Battery Test button for at least one second while operating from utility power and no alarm conditions are present.

The manual battery test should be initiated with fully charged batteries (all Battery Capacity LEDs on). The Battery Capacity LEDs will flash during the battery test.

## Standby/Manual Bypass button



This button controls output power to connected load(s) and has dual functions:

- Standby
- Manual bypass



### CAUTION

Pressing the Standby/Manual Bypass button during normal operation while the inverter is on will transfer the load to bypass power, if the bypass voltage and frequency are within a safe range.

Pressing the Standby/Manual Bypass button when the UPS is in bypass mode will shut off power to the output receptacles and connected loads. Turning the unit off leaves the UPS in standby mode. To fully isolate the load from power, open the input circuit breaker.

### **Load Level indicators - 4 green, 1 amber, 1 red LEDs**

The Load Level indicators display the approximate load level at all times.

- The four green LEDs indicate acceptable levels up to 95%.
- The amber light comes on when the load level is 96-105%.
- The last LED at right (red) indicates an overload (more than 105%) and warns of imminent shutdown if the load is not reduced.

### **Battery Capacity indicators - 5 green LEDs**

The GXT5000R-208 features an automatic battery test. The Battery Capacity LEDs display the approximate level of battery reserves.

An automatic test occurs every 28 days if utility power has not been interrupted. Should the battery fail this test, the Battery Capacity LEDs will flash and the failure code will be displayed.

### **Fault indicator - 1 red LED**

The Fault indicator LED is illuminated if the UPS detects a problem. Also, one or more of the Load Level/Battery Level indicators may be illuminated (refer to **Troubleshooting**).

### **On Bypass indicator - 1 amber LED**

The On Bypass indicator LED is illuminated when the UPS is operating from bypass power.

### **On Inverter indicator - 1 green LED**

The On Inverter indicator LED is illuminated when the UPS inverter is operating and supplying power to your connected loads.

### **AC Input indicator - 1 green LED**

The AC Input indicator LED is illuminated when utility power is available and falls within the input specification.

# MODES OF OPERATION

## Normal Mode Operation

During normal operation, utility power provides energy to the UPS. The filters, the power factor correction circuit and the inverter process this power to provide computer-grade power to connected loads. The UPS maintains the batteries in a fully charged state.

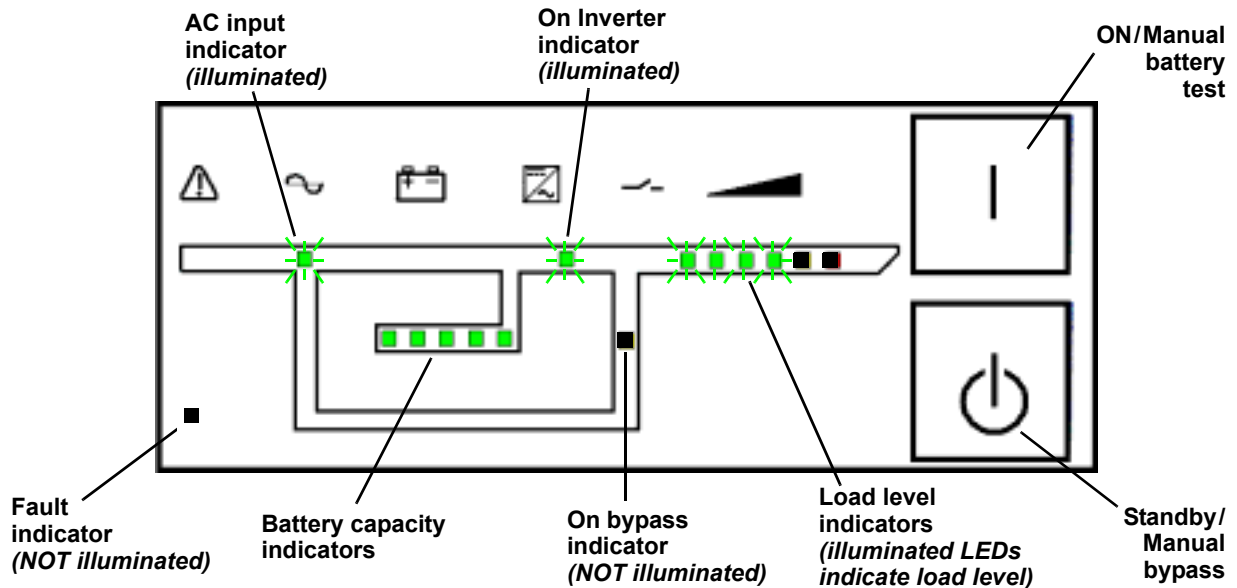

## Battery Mode Operation

The UPS will enter Battery mode if there is a power surge, extreme power drop, or utility failure. The battery system supplies power through the DC to DC converter to the inverter to generate power for the connected load.



### CAUTION

Turning off the UPS while in battery mode will shut off output power.

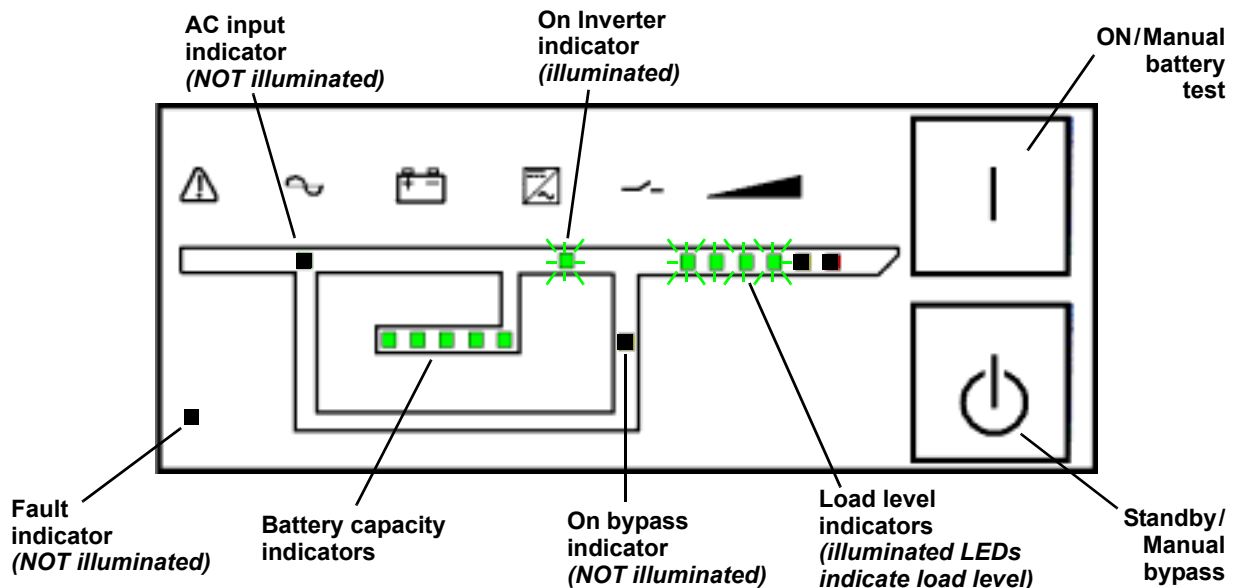



# Bypass Mode

Bypass mode provides an alternate path for utility power to the connected load in the unlikely event of a UPS malfunction, such as overload, overtemperature, or an internal UPS failure.

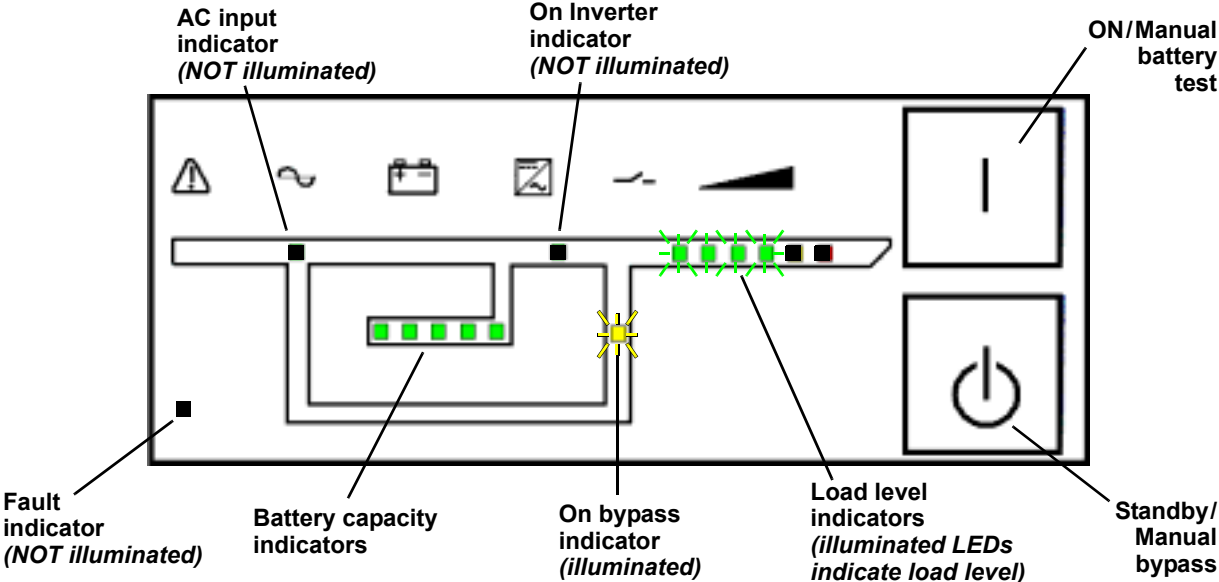

# Battery Recharge Mode

Once utility power is restored, the UPS resumes normal operation and the Battery Charger begins recharging the battery.

# OPERATING INSTRUCTIONS

## Turn On

Once the AC supply has been applied to the unit, power will be applied to the load (bypass mode) immediately when the 30 A input circuit breaker is initially closed. Turn the unit ON (inverter mode) by pressing the ON button  once.

## Manual Bypass

To manually put the unit in Bypass mode, press the Standby button  once. Pressing this button once will cause the load to be transferred to bypass power. Pressing this button a second time will result in loss of power to the output receptacles and connected loads.



### CAUTION

**Pressing the Standby/Manual Bypass button during normal operation while the inverter is on will transfer the load to bypass power, if the bypass voltage and frequency are within a safe range.**

**The bypass power path does NOT protect the connected equipment from disturbances on the utility supply.**

## Standby

To put the unit in Standby mode, press the Standby button  while the unit is in bypass mode.



### CAUTION

**Pressing the Standby/Manual Bypass button when the UPS is in bypass mode will shut off power to the output receptacles and connected loads. Turning the unit off leaves the UPS in standby mode. To fully isolate the load from power, open the input circuit breaker.**

## OPTIONAL BATTERIES - PROGRAMMABLE RUN TIME

The GXT5000R-208 may be equipped with up to five battery GXT5VBATT cabinets. At least one battery cabinet is required. The first battery cabinet may be a GXT5VBATTW120 if a 120V, 400VA auxiliary voltage source is needed.

The enhanced communication provides an estimated run time in minutes, taking into account the number of battery cabinets and UPS load. The number of attached battery cabinets must be programmed into the UPS for accurate time estimates.

Even when external monitoring software is not used, the enhanced accuracy is applied to the low battery contact closure alarm provided by the standard relay alarm card.

The front control panel provides a convenient method of programming the number of battery cabinets.

### Programming the GXT5000R-208 for Battery Cabinet Count

Programming the UPS uses the ON button, the Standby button, and the Load LEDs on the front control panel (see illustration at right).

The battery count display mode should be entered only with the UPS load off.

Once the battery count is displayed, the user has the option of leaving the battery count unchanged or modifying the count to match the number of attached battery cabinets.

The count should always be checked on new installations to confirm the setting.

In this mode, the Load LEDs function as Battery Count LEDs. On completion of the procedure, one to five Load LEDs illuminate to indicate how many battery cabinets are connected to the GXT5000R-208 (see illustration below).

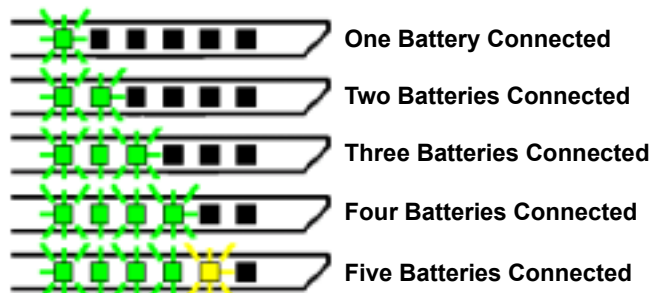
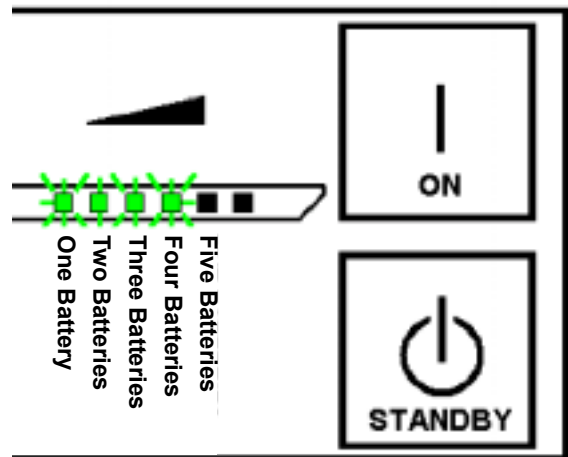

## Procedure to confirm the battery count

1. Apply AC input power to the UPS.
2. Turn the UPS output off using the Standby button. If the UPS is in inverter mode, the load must first be transferred to bypass and then to off.
3. Once the UPS output is off, press and hold the Standby button continuously. The Standby button must be held continuously for the duration of this procedure. The UPS will do nothing for the first 10 seconds. After approximately 10 seconds, the LED display will scroll and the horn will beep. When the LED display comes to rest (about 15 seconds after first pressing the Standby button), the battery cabinet count will be displayed on the Load LEDs. The count will display as long as the Standby button is continuously held.
4. If the Standby button is released at any time, the entire procedure must be restarted.
5. Once the battery count is displayed, or at any time if you wish to abort the procedure, you may release the Standby button and restart the UPS using the ON button.

## Procedure to change the battery count

This procedure required the simultaneous use of the Standby button and ON button. No other UPS procedure calls for simultaneously pressing the Standby and ON buttons.

The first three steps of this procedure repeats **Steps 1 through 3** in the **Procedure to confirm the battery count**. However, once the battery count is displayed, you have the option of changing the count. As before, the Standby button must be held continuously for the entire procedure. Releasing the button prematurely will require that the whole process be repeated.

1. Apply AC input power to the UPS.
2. Turn the UPS output off using the Standby button. If the UPS is in inverter mode, the load must first be transferred to bypass and then to off.
3. Once the UPS output is off, press and hold the Standby button continuously. After approximately 10 seconds, the LED display will scroll and the horn will beep. When the LED display comes to rest (about 15 seconds after first pressing the Standby button), the battery cabinet count will be displayed on the Load LEDs. The count will display as long as the Standby button is continuously held.
4. If the displayed battery count is incorrect, press the ON button for 1 second while simultaneously continuing to hold the Standby button. The display will scroll and the horn will beep, and the battery count will be increased by one.
5. If the desired battery count has not been reached, repeat **Step 4**. The count can only be increased. After a count of 5 is reached, the count will restart at 1.
6. Once the desired battery count is displayed—or at any time you wish to abort the procedure—you may release the Standby button and restart the UPS using the ON button.

# COMMUNICATIONS

Do not exceed NEC Class 2 limits for any connection to the DB-25 connector on the Relay Interface card, the DB-9 communication port, and the EPO connector.

## Relay Interface Card

Your GXT5000R-208 comes equipped with the RELAYCARD-INT relay card. Connections must not exceed NEC Class 2 limits.

The Intellislot<sup>®</sup> Interface for Relay Contacts card provides contact closures for remote monitoring of alarm conditions in your Liebert UPS, delivering signals for On Battery, On Bypass, Low Battery, Summary Alarm, UPS Fault and On UPS.

The contacts are rated for 24 VAC or DC at 1A.

## Pin Configuration

**Table 1 Pin configuration**

Pin	Function	Operation
1	UPS Fault	Closed if no UPS failure
2	Not Used	—
3	Not Used	—
4	UPS Fault	Closed if UPS fails
5	Summary Alarm*	Closed if SUMMARY ALARM* occurs
6	Summary Alarm*	Closed if no alarm conditions are present
7	Signal Ground (for UPS Any Mode Shutdown)	
8	Not Used	—
9	Common – Low Battery	
10	Low Battery	Closed if battery is OK
11	Low Battery	Closed if LOW BATTERY point occurs.
12	Not Used	—
13	Not Used	—
14	UPS Any Mode Shutdown (short to pin 7)	Not utilized on GXT5000R-208 - See <b>EPO</b> section
15	On UPS	Closed if ON UPS (inverter) power
16	On Battery	Closed if ON BATTERY power (Utility failure)
17	Common – UPS Fault, Summary Alarm, On UPS, On Battery, On Bypass	
18	On Battery	Closed if not ON Battery power (Utility OK)
19	Not Used	—
20	Not Used	—
21	Not Used	—
22	Not Used	—
23	Not Used	—
24	On Bypass	Closed if ON BYPASS
25	Not Used	—

- A Summary Alarm occurs when any of the following four conditions exist:
1. Utility power is out of the acceptable range (voltage and/or frequency).
  2. UPS is in BYPASS MODE (load not on Inverter power).
  3. UPS Battery is LOW (< 2 minutes of battery power remaining).
  4. UPS fault has occurred.

## **EPO**

This unit is equipped with provisions for the terminal connections for a UPS Emergency Power OFF Switch (EPO). The terminal is located on the rear of the UPS next to the DB-9 connector. If an EPO switch is used, it must have the characteristics of an emergency button—closed under normal conditions and held open mechanically when operated. If this connection is removed, the unit will not start up.

Connections must not exceed NEC Class 2 limits.

# SERIAL COMMUNICATIONS

The UPStationGXT5000R-208 has a DB-9 serial port male connector on the rear of the unit. Contact closure signals are not provided on this connector. Serial signals are provided on this port and are assigned as follows:

PIN	DESCRIPTION
1,4,6,7,8,9	Do not connect
2	UPS RxD (typical RS-232 levels)
3	UPS TxD (typical RS-232 levels)
5	Common

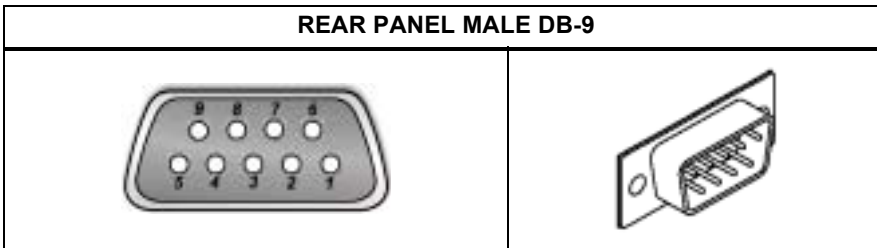

This port is not directly compatible with the Liebert M3LS9P9S serial communication cable supplied with the UPS. A DB-9 adapter must be used to provide a standard Liebert UPS communication port.

A DB-9 adapter is included in the UPS accessory box. Attach the adapter to the UPS using the captive screws.

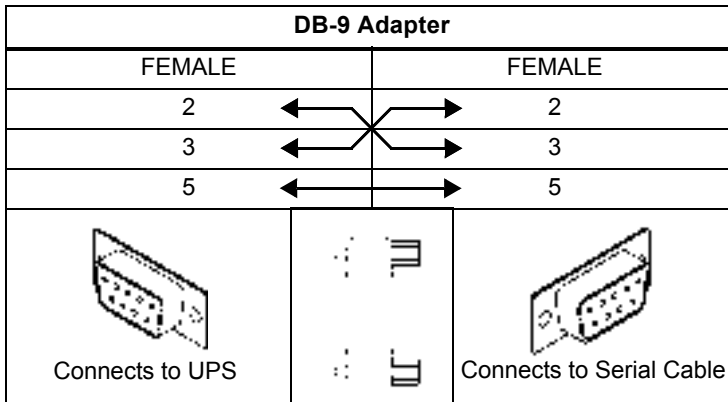

The DB-9 adapter will redirect the communication signals and provide a female DB-9 communication port suitable for connection to the Liebert M3LS9P9S serial communication.

## Serial Cable

Connect the DB-9 adapter to your computer serial port using the Liebert M3LS9P9S serial communication cable.

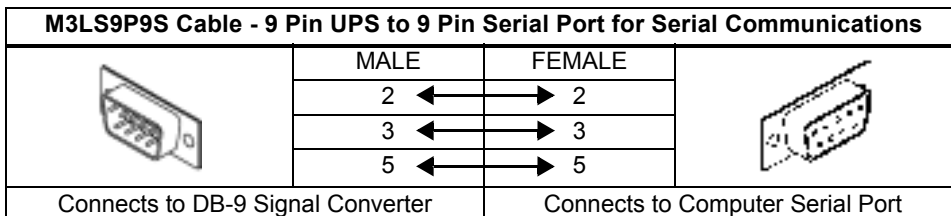

## UPS COMMUNICATIONS WITH INTELLISLOT

Your GXT5000R-208 comes equipped with the RELAYCARD-INT relay card. The addition of serial communications now expands the list of cards that may be used in the Intellislot.

The UPStation GXT5000R-208 UPS is equipped with an Intellislot bay to provide advanced communication and monitoring options.

Liebert's MultiLink™ software continually monitors the UPS via a serial cable and can shut down your computer or server in the event of an extended power failure.

MultiLink can also be configured for use without the serial cable when the Intellislot SNMP/Web card is installed in the UPS. Additionally, MultiLink can be configured to coordinate shutdown across the network with other computers running MultiLink when you purchase a MultiLink License Kit. For more information about the Intellislot SNMP/Web Card and MultiLink License Kits, please visit the Web site <http://multilink.liebert.com> or contact your local dealer or Liebert representative.

Several option cards are available for use in the Intellislot bay of the UPStation GXT5000R-208. The Intellislot SNMP/Web Card provides SNMP and Web-based monitoring and control of the UPS across the network.

The Intellislot MultiPort 4 Card allows you to install MultiLink software on four computers and coordinate an orderly shutdown in the event of a power failure.

The standard Intellislot Relay Card provides dry contact relay outputs for custom-wired applications and delivers support for built-in shutdown for AS/400 systems.



### CAUTION

**TO MAINTAIN SAFETY (SELV) BARRIERS AND FOR ELECTROMAGNETIC COMPATIBILITY, SIGNAL CABLES SHOULD BE SEGREGATED AND RUN SEPARATE FROM ALL OTHER POWER CABLES, WHERE APPLICABLE.**



## MAINTENANCE

The GXT5000R-208 UPS requires very little maintenance. The batteries are valve-regulated, nonspillable, lead acid and should be kept charged to obtain their design life. The UPS continuously charges the batteries when connected to the utility supply.

When storing the UPS for an extended period, connect it to utility power for at least 24 hours every six months to keep the batteries fully charged.



### **CAUTION**

**Only qualified service personnel may replace internal batteries in the battery cabinets.**

# TROUBLESHOOTING

This section presents various problems a user might encounter. Use this information to determine whether external factors cause the problem and how to remedy the situation.

1. The Fault LED will illuminate, indicating the UPS detected a problem.
2. An alarm will sound, alerting that the UPS requires attention.
3. One or more additional load/battery level LED indicators will be illuminated to provide a diagnostic aid to the operator, as shown below:

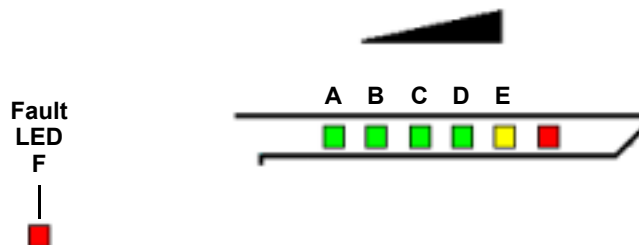

4. Record the LED condition and horn condition. Turn off the 30A AC input circuit breaker on the rear of the UPS and restart the UPS based on the **Operating Instructions** in this manual.

**Table 2 LED indicators**

LED status	Diagnosis	Audible alarm
All LEDs on	AC input overvoltage	Continuous beep
A, F on	On bypass due to overtemperature condition until the UPS cools, then re-transferring load to inverter.	Continuous beep
	Or off due to very high temperatures.	—
D, F on	Battery overvoltage	Continuous beep
E, F on	Battery mode overload	Half-second beep every 1 second
A, D, F on	Inverter output short	Continuous beep
Line LED flashing	Input AC present, but exceeds PFC input requirements (> 276 or < 170)	—
All battery capacity LEDs flashing	Battery failure warning	Continuous beep
B, C, F on	EPO shutdown	Continuous beep
Other	Record condition of LEDs and horn. Contact Liebert technical support.	—

If a problem persists, consult your local dealer, Liebert representative or the Liebert Worldwide Support Group—telephone numbers may be found on the back of this manual. Please have the UPS model number and serial number available at the time of your inquiry.

**Table 3 Troubleshooting guide**

Fault classification	LED display	Audible alarm	Condition	Response time
<b>Bus fault</b>	C & F LEDs	Continuous	± Bus V > 450 VDC	80 ms
			± Bus V > 410 VDC	1.5 seconds
			± Bus V < 230 VDC	80 ms
			$ (\text{Abnormal} + \text{Bus V}) - ( \text{-Bus V} )  > 40 \text{ VDC}$ or $ (+\text{Bus V}) - (\text{Abnormal}  \text{-Bus V} )  > 35 \text{ VDC}$	2 minutes
<b>Inverter fault</b>	B & F LEDs	Continuous	Inverter output power > 276 VAC or Inverter output power < 140 VAC	Minimum 90 ms
			Inverter output power short. UPS short circuit fault.	5 cycles
<b>Overtemp fault</b>	A & F LEDs	Continuous	If temperature is > 90°F (32°C) detected NTC's temperature on CNTL pcb.	5 seconds
			If temperature > 65°F (18°C) and < 90°F (32°C), then transfer to bypass mode, and wait until temperature < 40°F (5°C) then back to inverter mode	4.5 seconds
<b>Battery overvoltage fault</b>	D & F LEDs	Continuous	Battery voltage > 15V per unit	6.4 seconds
<b>Battery mode overload alarm</b>	E & F LEDs	0.5 second beep, recurring every 1 second	Battery mode load > 105%, < 125%	1 minute
			Battery mode load > 125%, < 150%	10 seconds
			Battery mode load > 150%	Instantaneous
<b>Bypass fault</b>	A, B & F LEDs	Continuous	Try to turn unit on (inverter mode). Check output load for shorts.	Instantaneous
<b>Relay bonded on N.O.</b>	A, C & F LEDs	Continuous	Check inverter output voltage, before inverter soft start. If detected inverter output voltage > 85 VAC, then set fault.	Instantaneous
<b>Inverter mode output power short circuit fault</b>	A, D & F LEDs	Continuous	If detected inverter output power I > 70 ADC and output voltage < 90 VDC, then increase {short_cnt}. If {short_cnt} > 30 any time in period of 96 ms, then set UPS short circuit fault.	Not specified
<b>Line LED flash warning</b>	—	—	Line voltage > 276 VAC	48 ms
			Line voltage < 170 VAC	160 ms or (48 ms)
<b>Battery disconnected warning</b>	BAT LED flashing	0.5 second beep, recurring every 1 second	When UPS turn off charger and detected battery voltage < 10 VDC per unit	Instantaneous
<b>Battery fail warning</b>	BAT LED flashing	Continuous	When the UPS is in battery test sequence and detected battery voltage < 10 VDC per unit	Instantaneous
<b>Bypass mode bus overvoltage or input voltage too high fault</b>	All LEDs bright, buzzer beeping	Continuous	Bus overvoltage > 400 VDC or input voltage > 292 VAC	Not specified
<b>Input voltage &gt; 292 VAC</b>	All LEDs bright, buzzer beeping	Continuous	Check input voltage—must be greater than 292 VAC.	Not specified
<b>BUS voltage fault</b>	All LEDs bright, buzzer beeping	Continuous	Check the BUS voltage—must be lower than 242 VDC.	Not specified

# SPECIFICATIONS

<b>MODEL NUMBER</b>	GXT5000R-208
<b>MODEL RATING VA/W</b>	5000 / 3750
<b>DIMENSIONS: inches (mm)</b>	
Unit: W x D x H	16.1 x 23.6 x 5.1(410 x 600 x 130)
Shipping: W x D x H	23.2 x 31.1 x 12.8 (590 x 790 x 325)
<b>WEIGHT: lbs (kg)</b>	
Unit	41.2 (18.7)
Shipping	53.8 (24.4)
<b>INPUT AC PARAMETERS</b>	
Voltage Range	208 VAC Nominal: 176-276 VAC
Frequency	50/60 Hz, ±5%; Auto Sensing
Input Power Cord	10 ft. attached, w/ NEMA L6-30P
<b>OUTPUT AC PARAMETERS</b>	
Output Receptacles	L6-30R (1), L6-20R (1)
Voltage	208 VAC, ±3%
Frequency	50 Hz or 60 Hz
Waveform	Sinewave
Main Mode Overload	151 - 300% for 2 seconds; 126 - 150% for 10 seconds; 105 - 125% for 60 seconds with transfer to bypass
<b>DC INPUT PARAMETERS</b>	
Voltage	240 VDC Nominal
Recharge Time	8 Hours to 90% capacity after full discharge into 100% load
<b>ENVIRONMENTAL</b>	
Operating Temperature	+32°F to +104°F (0°C to +40°C)
Storage Temperature	+5°F to +122°F (-15°C to +50°C)
Relative Humidity	0% to 95%, non-condensing
Operating Elevation	Up to 10,000 ft. (3000 m) at 104°F (40°C) without derating
Storage Elevation	50,000 ft. (15,000 m) maximum
Audible Noise	< 55 dBA
<b>AGENCY</b>	
Safety	UL 1778, c-UL Listed
RFI/EMI	FCC Part 15, Subpart B, Class A
Transportation	ISTA Procedure 1A

# BATTERY CABINET SPECIFICATIONS

## GXT5VBATTW120

<b>MODEL NUMBER</b>	GXT5VBATTW120
<b>DIMENSIONS: inches (mm)</b>	
Unit: W x D x H	16.1 x 23.6 x 5.1 (410 x 600 x 130)
Shipping: W x D x H	23.2 x 31.1 x 12.8 (590 x 790 x 325)
<b>WEIGHT: lbs (kg)</b>	
Unit	121.7 (55.2)
Shipping	132.3 (60.0)
<b>AC PARAMETERS – AUXILIARY AC POWER</b>	
Nominal AC Input	208 VAC, 50/60 Hz, 400 VA, Single-Phase
Nominal AC Output	120 VAC, 50/60 Hz, 400 VA, 0.75 PF (Power Factor)
Output Receptacles	5-15R (2)
<b>BATTERY PARAMETERS</b>	
Type	Valve-regulated, nonspillable, lead acid
Qty. x Battery Voltage x Battery Rating	20 x 12 VDC x 28 watts per cell (10-minute rate)
Battery Mfg./ Part #	Yuasa 28-12
<b>ENVIRONMENTAL</b>	
Operating Temperature	+32°F to +104°F (0°C to +40°C)
Storage Temperature	+5°F to +122°F (-15°C to +50°C)
Relative Humidity	0% to 95%, non-condensing
Operating Elevation	Up to 10,000 ft. (3000 m) at 104°F (40°C) without derating
<b>AGENCY</b>	
Safety	UL 1778, c-UL Listed
RFI/EMI	FCC Part 15, Subpart B, Class A
Transportation	ISTA Procedure 1A

## GXT5VBATT

<b>MODEL NUMBER</b>	GXT5VBATT
<b>DIMENSIONS: inches (mm)</b>	
Unit: W x D x H	16.1 x 18.5 x 5.1 (410 x 470 x 130)
Shipping: W x D x H	23.2 x 31.1 x 12.8 (590 x 790 x 325)
<b>WEIGHT: lbs (kg)</b>	
Unit	107.3 (48.7)
Shipping	116.6 (52.9)
<b>BATTERY PARAMETERS</b>	
Type	Valve regulated, nonspillable, lead acid
Qty. x Battery Voltage x Battery Amp Rating	20 x 12 VDC x 28 watts per cell (10-minute rate)
Battery Mfg./ Part #	Yuasa 28-12
<b>ENVIRONMENTAL</b>	
Operating Temperature	+32°F to +104°F (0°C to +40°C)
Storage Temperature	+5°F to +122°F (-15°C to +50°C)
Relative Humidity	0% to 95%, non-condensing
Operating Elevation	Up to 10,000 ft. (3000 m) at 104°F (40°C) without derating
<b>AGENCY</b>	
Safety	UL 1778, c-UL Listed
RFI/EMI	FCC Part 15, Subpart B, Class A
Transportation	ISTA Procedure 1A



**DISCONTINUED  
PRODUCT**

# **GXT5000R-208**

**with GXT5VBATTW120 / GXT5VBATT Battery Cabinets**

**USER MANUAL**

## **The Company Behind the Products**

With over a million installations around the globe, Liebert is the world leader in computer protection systems. Since its founding in 1965, Liebert has developed a complete range of support and protection systems for sensitive electronics:

- Environmental systems—Close-control air conditioning from 1 to 60 tons
- Power conditioning and UPS with power ranges from 300 VA to more than 1000 kVA
- Integrated systems that provide both environmental and power protection in a single, flexible package
- Monitoring and control—From systems of any size or location, on-site or remote
- Service and support through more than 100 service centers around the world and a 24/7 Customer Response Center

While every precaution has been taken to ensure the accuracy and completeness of this literature, Liebert Corporation assumes no responsibility and disclaims all liability for damages resulting from use of this information or for any errors or omissions.

© 2002 Liebert Corporation

All rights reserved throughout the world. Specifications subject to change without notice.

® Liebert and the Liebert logo are registered trademarks of Liebert Corporation. All names referred to are trademarks or registered trademarks of their respective owners.

23156, Rev. 0 (7/02)

## **Technical Support/Service**

### **Web Site**

[www.liebert.com](http://www.liebert.com)

### **Monitoring**

800-222-5877

[monitoring@liebert.com](mailto:monitoring@liebert.com)

Outside the US: 614-841-6755

### **Single-Phase UPS**

800-222-5877

[upstech@liebert.com](mailto:upstech@liebert.com)

Outside the US: 614-841-6755

### **Three-Phase UPS**

800-543-2378

[powertech@liebert.com](mailto:powertech@liebert.com)

### **Environmental Systems**

800-543-2778

### **Outside the United States**

614-888-0246

## **Locations**

### **United States**

1050 Dearborn Drive

P.O. Box 29186

Columbus, OH 43229

### **Italy**

Via Leonardo Da Vinci 8

Zona Industriale Tognana

35028 Piove Di Sacco (PD)

+39 049 9719 111

Fax: +39 049 5841 257

### **Asia**

23F, Allied Kajima Bldg.

138 Gloucester Road

Wanchai

Hong Kong

+852 2 572 220

Fax: +852 2 831 011