

**DISCONTINUED
PRODUCT**



POWER PROTECTION

Series 600T™ UPS

**Single Module Three Phase
500 kVA to 750 kVA, 60 Hz**

**Installation
Manual**

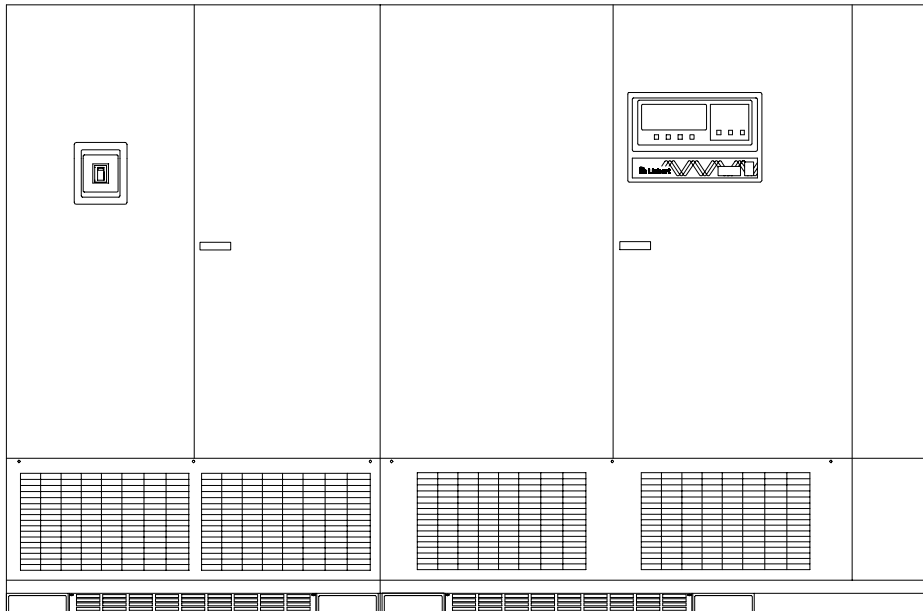

**DISCONTINUED
PRODUCT**

Table of Contents

1.0	SAFETY PRECAUTIONS	3
2.0	INSTALLATION CONSIDERATIONS	4
3.0	UNLOADING AND HANDLING	5
4.0	INSPECTIONS	
	4.1 External Inspections	6
	4.2 Internal Inspections	6
5.0	EQUIPMENT LOCATION	7
6.0	BATTERY INSTALLATION	
	6.1 Battery Safety Precautions	8
	6.2 Battery Cabinets	11
	6.3 Non-Standard Batteries	11
7.0	CONFIGURING YOUR GROUND AND NEUTRAL CONNECTIONS	
	7.1 Preferred Grounding Configuration, Wye-Connected Service	13
	7.2 Alternative Grounding Configuration, Wye-Connected Service	14
	7.3 Grounding Configuration, Delta Source or Impedance-Grounded Wye	15
	7.4 Preferred Grounding Configuration with Power-Tie™ Switchgear	16
	7.5 Preferred Grounding Configuration, Battery Systems	17
8.0	WIRING CONSIDERATIONS	
	8.1 Power and Control Wiring	19
	8.2 Battery Wiring	19
9.0	WIRING CONNECTIONS	21
10.0	WIRING INSPECTION	
	Table 1 Power Wiring Terminals - Factory Supplied	24
	Table 2 Torque Specifications	24
	Table 3 Table 310-16	25
11.0	INSTALLATION DRAWINGS	26
12.0	APPENDIX A - SITE PLANNING DATA	
	Table 4 Site Planning Data, 480 Volt Input	63
	Table 5 Site Planning Data, 600 Volt Input	64
	Table 6 Circuit Breaker Ratings	64
13.0	APPENDIX B - FIELD SUPPLIED LUGS	
	Table 7 One-Hole Lugs	65

**DISCONTINUED
PRODUCT**

List of Figures

Figure 1	Preferred Grounding Configuration, 480 or 600 VAC input and output.	13
Figure 2	Alternative Grounding Configuration, 480 or 600 VAC input and output	14
Figure 3	Preferred Grounding Configuration with Delta Source Input	15
Figure 4	Preferred Grounding Configuration, Power-Tie™ Systems.	16
Figure 5	Preferred Battery Cabinet Grounding Configuration	17
Figure 6	Typical Power Wiring.	20
Figure 7	Outline Drawing, 500 kVA Single Module UPS, 6-Pulse Rectifier	26
Figure 8	Outline Drawing, 500 kVA Single Module UPS, 12-Pulse Rectifier	27
Figure 9	Outline Drawing, 625-750 kVA Single Module UPS, 6-Pulse Rectifier	28
Figure 10	Outline Drawing, 625-750 kVA Single Module UPS, 12-Pulse Rectifier	29
Figure 11	Battery Cabinet, Size A	30
Figure 12	Battery Cabinet, Size B	31
Figure 13	Parallel Battery Power Pack	32
Figure 14	Base Mounting Patterns, 500 kVA SMS, 12-Pulse Rectifier	33
Figure 15	Base Mounting Patterns, 625-750 kVA SMS, 6-Pulse Rectifier	34
Figure 16	Base Mounting Patterns, 625-750 kVA SMS, 12-Pulse Rectifier	35
Figure 17	Shipping Split Detail, 500 kVA SMS, 12-Pulse Rectifier	36
Figure 18	Shipping Split Detail, 625-750 kVA SMS, 6-Pulse Rectifier	37
Figure 19	Shipping Split Detail, 625-750 kVA SMS, 12-Pulse Rectifier	38
Figure 20	Bussing Details, 500 kVA SMS, 6-Pulse Rectifier	39
Figure 21	Bussing Details, 500 kVA SMS, 12-Pulse Rectifier	40
Figure 22	Bussing Details, 625-750 SMS, 12-Pulse Rectifier	41
Figure 23	Bussing Details, 750 kVA/675 kW Standard and 750 kVA/600 kW Optional Input Busbars	42
Figure 24	Control Wiring, External Interconnect Diagram	43
Figure 25	Control Connection Location Diagram, 500 kVA SMS.	44
Figure 26	Control Connection Location Diagram, 625-750 kVA SMS	45
Figure 27	Control Wire List, External Interconnections, 500-750 kVA SMS	46
Figure 28	Control Wiring, Alarm Status Contacts Option	47
Figure 29	Control Wiring, Maintenance Bypass Interlock Option.	48
Figure 30	Control Wiring, Remote Status Panel Interface Option.	49
Figure 31	Control Wiring, Remote Terminal IFM (RS-232 Communications) Option	50
Figure 32	Control Wiring, SiteScan Interface	51
Figure 33	Control Wiring, Customer Alarm Interface Option	52
Figure 34	Control Wiring, Battery Temperature Sensor Interface	53
Figure 35	Control Wiring, SNMP Interface Option.	54
Figure 36	Control Wiring, Internal Modem Option.	55
Figure 37	Control Wiring, Maintenance Bypass Cabinet Option.	56
Figure 38	Wiring Configurations, UPS Video Display Terminal	57
Figure 39	Outline Drawing, Module Battery Disconnect, 500 kVA SMS with 6-Pulse Rectifier	58
Figure 40	Outline Drawing, Module Battery Disconnect, 500-750 kVA SMS with 12-Pulse Rectifier	59
Figure 41	Remote Status Panel, Surface Mount	60
Figure 42	Circuit Breaker Schedule, 300-750 kVA	61

IMPORTANT SAFETY INSTRUCTIONS

Save These Instructions.

This manual contains important instructions that should be followed during installation of your Series 600T UPS and batteries.



WARNING

EXERCISE EXTREME CARE WHEN HANDLING UPS CABINETS TO AVOID EQUIPMENT DAMAGE OR INJURY TO PERSONNEL. THE UPS MODULE WEIGHT RANGES FROM 4200 POUNDS (1909 KG) TO 9170 POUNDS (4170 KG), INCLUDING TRANSFORMER CABINET. THE BATTERY CABINETS WEIGH BETWEEN 3000 POUNDS (1364 KG) AND 4900 POUNDS (2227 KG).

LOCATE CENTER OF GRAVITY SYMBOLS BEFORE HANDLING EACH CABINET. TEST LIFT AND BALANCE THE CABINETS BEFORE TRANSPORTING. MAINTAIN MINIMUM TILT FROM VERTICAL AT ALL TIMES.

SLOTS AT THE BASE OF THE MODULES AND BATTERY CABINETS ARE INTENDED FOR FORKLIFT USE. BASE SLOTS WILL SUPPORT THE UNIT ONLY IF THE FORKS ARE COMPLETELY BENEATH THE UNIT.

FOLLOW ALL BATTERY SAFETY PRECAUTIONS WHEN INSTALLING, CHARGING, OR SERVICING BATTERIES. IN ADDITION TO THE HAZARD OF ELECTRIC SHOCK, GAS PRODUCED BY BATTERIES CAN BE EXPLOSIVE AND SULFURIC ACID CAN CAUSE SEVERE BURNS.

IN CASE OF FIRE INVOLVING ELECTRICAL EQUIPMENT, ONLY CARBON DIOXIDE FIRE EXTINGUISHERS, OR THOSE APPROVED FOR USE IN ELECTRICAL FIRE FIGHTING, SHOULD BE USED.

EXTREME CAUTION IS REQUIRED WHEN PERFORMING MAINTENANCE.

BE CONSTANTLY AWARE THAT THE UPS SYSTEM CONTAINS HIGH DC AS WELL AS AC VOLTAGES.

CHECK FOR VOLTAGE WITH BOTH AC AND DC VOLTMETERS PRIOR TO MAKING CONTACT.



WARNING

**LOCATE CENTER OF GRAVITY SYMBOLS 
AND DETERMINE UNIT WEIGHT
BEFORE HANDLING CABINET.**

If you require assistance for any reason, call the toll-free Liebert Global Services number; 1-800-543-2378. For LGS to assist you expediently, please have the following information available:

Part Number: _____
Serial Number: _____
kVA Rating: _____
Date Purchased: _____
Date Installed: _____
Location: _____
Input Voltage: _____
Output Voltage: _____
Battery Reserve Time: _____

1.0 SAFETY PRECAUTIONS

Read this manual thoroughly, paying special attention to the sections that apply to you, before working with the UPS. **Retain this manual for use by installing personnel.**

Under typical operation and with all UPS doors closed, only normal safety precautions are necessary. The area around the UPS system should be kept free from puddles of water, excess moisture, or debris.

Special safety precautions are required for procedures involving handling, installation, and maintenance of the UPS system or the battery. Observe all safety precautions in this manual before handling or installing the UPS system. Observe all precautions in the **Operation and Maintenance Manual**, before as well as during performance of all maintenance procedures. Observe all battery safety precautions before working on or near the battery.

This equipment contains several circuits that are energized with high voltage. Only test equipment designated for troubleshooting should be used. This is particularly true for oscilloscopes. Always check with an AC and DC voltmeter to ensure safety before making contact or using tools. Even when the power is turned Off, dangerously high potentials may exist at the capacitor banks and at the batteries.

ONLY qualified service personnel should perform maintenance on the UPS system. When performing maintenance with any part of the equipment under power, service personnel and test equipment should be standing on rubber mats. The service personnel should wear insulating shoes for isolation from direct contact with the floor (earth ground).

Unless all power is removed from the equipment, one person should never work alone. A second person should be standing by to assist and summon help in case an accident should occur.

Three types of messages are used throughout the manual to stress important text. Carefully read the text below each Warning, Caution, and Note and use professional skills and prudent care when performing the actions described by that text.

A **Warning** signals the presence of a possible serious, life-threatening condition. For example:



WARNING

LETHAL VOLTAGES MAY BE PRESENT WITHIN THIS UNIT EVEN WHEN IT IS APPARENTLY NOT OPERATING. OBSERVE ALL CAUTIONS AND WARNINGS IN THIS MANUAL. FAILURE TO DO SO COULD RESULT IN SERIOUS INJURY OR DEATH. DO NOT WORK ON OR OPERATE THIS EQUIPMENT UNLESS YOU ARE FULLY QUALIFIED TO DO SO!! NEVER WORK ALONE.

A **Caution** indicates a condition that could seriously damage equipment and possibly injure personnel. For example:



CAUTION

Extreme care is necessary when removing shoring braces. Do not strike the cabinet with hammers or other tools.

A **Note** emphasizes important text. If the note is not followed, equipment could be damaged or may not operate properly. For example:



NOTE

If the UPS system has a blown fuse, the cause should be determined before you replace the fuse. Contact Liebert Global Services.

2.0 INSTALLATION CONSIDERATIONS

Install your Series 600T UPS in accordance with the submittal drawing package and the following procedures.

A Liebert authorized representative must perform the initial system check-out and start-up to ensure proper system operation. Equipment warranties will be voided unless system start-up is performed by a Liebert authorized representative. Contact your local Liebert sales representative or Liebert Global Services at **1-800-543-2378** to arrange for system start-up.



CAUTION

Read this manual thoroughly before attempting to wire or operate the unit. Improper installation is the most significant cause of UPS start-up problems.

Do not install this equipment near gas or electric heaters. It is preferable to install the UPS in a restricted location to prevent access by unauthorized personnel.

1. Proper planning will speed unloading, location, and connection of the UPS. **Refer to Figure 7 through Figure 33 and Appendix A - Site Planning Data.**
2. Refer to information later in this manual regarding the optional Battery Cabinet(s), Maintenance Bypass Cabinet, and Transformer Cabinet. **Observe all battery safety precautions when working on or near the battery.**
3. Use the shortest output distribution cable runs possible, consistent with logical equipment arrangements and with allowances for future additions if planned.
4. Recommended ambient operating temperature is 25°C (77°F). Relative humidity must be less than 95%, non-condensing. Note that room ventilation is necessary, but air conditioning may not be required. Maximum ambient operating temperature is 40°C (104°F) without derating. The batteries should not exceed 25°C (77°F). At elevations above 4,000 feet (1219 meters) derating may be required (consult your Liebert sales representative).
5. Even though your Liebert UPS unit is 92.5 to 94% efficient, the heat output is substantial. For more specific information, see **Appendix A - Site Planning Data**. Be sure environmental conditioning systems can accommodate this BTU load, even during utility outages.
6. The routing (inside the facility) to the installation site, as well as the floor at the final equipment location, must be capable of supporting the cabinet weight and the weight of any moving equipment. The modules weigh between 5,000 and 10,000 pounds. The battery cabinets weigh between 3100 and 5100 pounds. Refer to **Appendix A - Site Planning Data**.
7. Plan the routing to ensure that the unit can move through all aisleways, doorways, and around corners without risking damage. If the modules and batteries must be moved by elevator, check the size of the door openings and the weight-carrying capacity of the elevator.



WARNING

LOCATE CENTER OF GRAVITY SYMBOLS AND DETERMINE UNIT WEIGHT BEFORE HANDLING CABINET.



3.0 UNLOADING AND HANDLING

The UPS module is shipped in one cabinet to allow easy handling at the site. Because the weight distribution in the cabinet is uneven, use extreme care during handling and transport. Your installation may also include Battery Cabinet(s), a Maintenance Bypass Cabinet, and an optional transformer cabinet.



WARNING

EXERCISE EXTREME CARE WHEN HANDLING UPS CABINETS TO AVOID EQUIPMENT DAMAGE OR INJURY TO PERSONNEL. THE UPS MODULE WEIGHT RANGES FROM 2770 POUNDS TO 7500 POUNDS, NOT INCLUDING THE OPTIONAL TRANSFORMER CABINET. BATTERY CABINETS WEIGH BETWEEN 3100 AND 5100 POUNDS.

LOCATE CENTER OF GRAVITY SYMBOLS BEFORE HANDLING CABINET. TEST LIFT AND BALANCE THE CABINET BEFORE TRANSPORTING. MAINTAIN MINIMUM TILT FROM VERTICAL AT ALL TIMES. SLOTS AT THE BASE OF THE UNIT ARE INTENDED FOR FORKLIFT USE. BASE SLOTS WILL SUPPORT THE UNIT ONLY IF THE FORKS ARE COMPLETELY BENEATH THE UNIT.

To reduce the possibility of shipping damage, cabinets are shored with 2x4 bracing, secured with screw-type nails. This shoring must be carefully removed prior to unloading.



CAUTION

Extreme care is necessary when removing shoring braces. Do not strike cabinet with hammers or other tools.

4.0 INSPECTIONS

4.1 External Inspections

1. While the UPS system is still on the truck, inspect the equipment and shipping container(s) for any signs of damage or mishandling. Do not attempt to install the system if damage is apparent. If any damage is noted, file a damage claim with the shipping agency within 24 hours and contact Liebert Global Services at 1-800-543-2378 to inform them of the damage claim and the condition of the equipment.
2. Locate the bag containing the keys for the front access door. The bag is attached to the cabinet.
3. Compare the contents of the shipment with the bill of lading. Report any missing items to the carrier and to Liebert Global Services immediately.
4. Check the nameplate on the cabinet to verify that the model number corresponds with the one specified. Record the model number and serial number in the front of this installation manual. A record of this information is necessary should servicing become required.

4.2 Internal Inspections

1. Verify that all items have been received.
2. If spare parts were ordered, verify arrival.
3. Open doors and remove cabinet panels to check for shipping damage to internal components.
4. Check for loose connections or unsecured components in the cabinet(s).
5. Check for installation of circuit breaker line safety shields. There should be no exposed circuit breaker terminals when the cabinet doors are opened.
6. Check for any unsafe condition that may be a potential safety hazard.
7. UPS modules are shipped with internally mounted shipping brackets. The shipping brackets (painted orange) must be removed from the rear (remove rear panels).

5.0 EQUIPMENT LOCATION

1. Handle cabinet(s) in accordance with **WARNINGS in 16.0 - Unloading and Handling**. Use a suitable material handling device to move cabinet to its final location. **Exercise extreme care because of the uneven weight distribution**. Carefully lower the cabinet to the floor.
2. Verify that the UPS system is installed in a clean, cool and dry location.
3. Installation and serviceability will be easier if adequate access is provided on all sides of the equipment, but only front access is required.
 - a. Verify that there is adequate clearance to open cabinet doors. See drawings and local codes (4 feet is recommended).
 - b. Verify that there is adequate area in front of circuit breakers to perform maintenance. Check installation drawings for location of breakers. Check with local codes.
 - c. Verify that there is adequate clearance above all cabinets to allow exhaust air to flow without restriction (2 feet minimum, unobstructed).

6.0 BATTERY INSTALLATION

6.1 Battery Safety Precautions

Servicing of batteries should be performed or supervised by personnel knowledgeable of batteries and the required precautions. Keep unauthorized personnel away from batteries.

When replacing batteries, use the same number and type of batteries.



CAUTION

Lead-acid batteries contain hazardous materials. Batteries must be handled, transported, and recycled or discarded in accordance with federal, state, and local regulations. Because lead is a toxic substance, lead-acid batteries should be recycled rather than discarded.

Do not open or mutilate the battery or batteries. Released electrolyte is harmful to the skin and eyes. It may be toxic. Do not dispose of battery or batteries in a fire. The battery may explode.

A battery can present a risk of electrical shock and high short circuit current. The following precautions should be observed when working on batteries:

- 1. Remove watches, rings, or other metal objects.**
- 2. Use tools with insulated handles.**
- 3. Wear rubber gloves and boots.**
- 4. Do not lay tools or metal parts on top of batteries.**
- 5. Disconnect charging source prior to connecting or disconnecting battery terminals.**
- 6. Determine if battery is inadvertently grounded. If inadvertently grounded, remove source of ground. Contact with any part of a grounded battery can result in electrical shock. The likelihood of such shock will be reduced if such grounds are removed during installation and maintenance.**

Lead-acid batteries can present a risk of fire because they generate hydrogen gas. The following procedures should be followed:

- 1. DO NOT SMOKE when near batteries.**
- 2. DO NOT cause flame or spark in battery area.**
- 3. Discharge static electricity from body before touching batteries by first touching a grounded metal surface.**

Battery Safety Precautions in French Per CSA Requirements

Instructions Importantes Concernant La Sécurité

Conserver Ces Instructions



ADVERTISSEMENT

DES PIÈCES SOUS ALIMENTATION SERONT LAISSÉES SANS PROTECTION DURANT CES PROCÉDURES D'ENTRETIEN. UN PERSONNEL QUALIFIÉ EST REQUIS POUR EFFECTUER CES TRAVAUX.

LES FUSIBLES A C.C. DE LA BATTERIE D'ACCUMULATEURS OPÈRENT EN TOUT TEMPS A LA TENSION NOMINALE. LA PRÉSENCE D'UN FUSIBLE A C.C. BRÛLE INDIQUE UN PROBLÈME SÉRIEUX. LE REMPLACEMENT DE CE FUSIBLE, SANS AVOIR DÉTERMINÉ LES RAISONS DE LA DÉFECTUOSITÉ, PEUT ENTRAINER DES BLESSURES OU DES DOMMAGES SÉRIEUX À L'ÉQUIPEMENT. POUR ASSISTANCE, APPELER LE DÉPARTEMENT DE SERVICE À LA CLIENTÈLE DE LIEBERT.



DANGER

Les accumulateurs plomb-acide contiennent de la matière comportant un certain risque. Les accumulateurs doivent être manipulés, transportés et recyclés ou éliminés en accord avec les lois fédérales, provinciales et locales. Parce que le plomb est une substance toxique, les accumulateurs plomb-acide devraient être recyclés plutôt qu'éliminés.

Il ne faut pas brûler le ou les accumulateurs. L'accumulateur pourrait alors exploser.

Il ne faut pas ouvrir ou endommager le ou les accumulateurs. L'électrolyte qui pourrait s'en échapper est dommageable pour la peau et les yeux.

Un accumulateur représente un risque de choc électrique et de haut courant de court-circuit. Lorsque des accumulateurs sont manipulés, les mesures préventives suivantes devraient être observées:

- 1. Retirer toutes montres, bagues ou autres objets métalliques.**
- 2. Utiliser des outils avec manchon isolé.**
- 3. Porter des gants et des bottes de caoutchouc.**
- 4. Ne pas déposer les outils ou les pièces métalliques sur le dessus des accumulateurs.**
- 5. Interrompre la source de charge avant de raccorder ou de débrancher les bornes de la batterie d'accumulateurs.**
- 6. Déterminer si l'accumulateur est mis à la terre par erreur. Si oui, défaire cette mise à la terre. Tout contact avec un accumulateur mis à la terre peut se traduire en un choc électrique. La possibilité de tels chocs sera réduite si de telles mises à la terre sont débranchées pour la durée de l'installation ou de l'entretien.**

Les accumulateurs plomb-acide présentent un risque d'incendie parce qu'ils génèrent des gaz à l'hydrogène. Les procédures suivantes devront être respectées.

1. **NE PAS FUMER** lorsque près des accumulateurs.
2. **NE PAS** produire de flammes ou d'étincelles près des accumulateurs.
3. Décharger toute électricité statique présente sur votre corps avant de toucher un accumulateur en touchant d'abord une surface métallique mise à la terre.



DANGER

L'électrolyte est un acide sulfurique dilué qui est dangereux au contact de la peau et des yeux. Ce produit est corrosif et aussi conducteur électrique. Les procédures suivantes devront être observées:

1. Porter toujours des vêtements protecteurs ainsi que des lunettes de protection pour les yeux.
2. Si l'électrolyte entre en contact avec la peau, nettoyer immédiatement en rinçant avec de l'eau.
3. Si l'électrolyte entre en contact avec les yeux, arroser immédiatement et généreusement avec de l'eau. Demander pour de l'aide médicale.
4. Lorsque l'électrolyte est renversée, la surface affectée devrait être nettoyée en utilisant un agent neutralisant adéquat. Une pratique courante est d'utiliser un mélange d'approximativement une livre (500 grammes) de bicarbonate de soude dans approximativement un gallon (4 litres) d'eau. Le mélange de bicarbonate de soude devra être ajouté jusqu'à ce qu'il n'y ait plus apparence de réaction (mousse). Le liquide résiduel devra être nettoyé à l'eau et la surface concernée devra être asséchée.

6.2 Battery Cabinets

Two sizes of optional battery cabinets are available. Refer to **Figure 11** through **Figure 13**. The battery cabinet cells range from 90 to 150 Ampere-hours. The same model battery cabinet may be paralleled in multiple cabinet strings for additional capacity. Battery capacity (in minutes) at your installation will depend on cabinet model, number of cabinets, and amount of critical load on the UPS.

1. **Handling.** The Battery Cabinet weighs between 3100 and 5100 pounds. Forklift slots are provided for easy handling.
2. **Cabinet Inspection.** Remove all panels and visually inspect the batteries, bus connections, and cabinet for any damage. **Exercise caution; voltage is present within the Battery Cabinet even before installation.** If there are signs of damage, do not proceed. Call Liebert Global Services at 1-800-542-2378.
3. **Battery Storage.** The batteries used in the Battery Cabinet have an excellent charge retaining characteristic. The batteries can be stored for up to six months without any appreciable deterioration. Self-discharge rate of the batteries is approximately 3% per month when the batteries are stored in temperatures of 15°C to 25°C (59°F to 77°F). If the Battery Cabinet must be stored for longer than six months, contact Liebert Global Services for recommended action.
4. **Installation.** The Battery Cabinet(s) can be located conveniently next to the UPS module. The front-access-only-design eliminates side and rear service clearance requirements.
 - **Environment.** Locate the Battery Cabinet in a clean, dry environment. Recommended temperature range for optimum performance and lifetime is 20°C (68°F) to 25°C (77°F).
 - **Service Clearance.** Allow front access to the Battery Cabinet at all times for maintenance and servicing. Electrical codes require that the Battery Cabinet be installed with no less than 3 feet (1 meter) of clearance at the front of the cabinet when operating. Side and rear panels do not require service clearance.
 - **Side Panels.** Remove protective side panels to connect battery cabinets together. Panels are retained at the bottom with three screws.
 - **Shield Plate.** The shield plate in each Battery Cabinet should be on the side toward the UPS system. Move the shield if required by your Battery Cabinet location.
 - **Cables.** Cables may be run between the cabinets through cutouts in the top of the cabinets, eliminating the need for external conduit runs. **Route cables before moving cabinets into final position for bolting together.** Remove top panels for access. No top or bottom entry cables are required, except for remotely located cabinets which require conduits. Refer to **Figure 11** through **Figure 13**.



NOTE

The 300-450 kVA UPS module is approximately 2 inches deeper than the Battery Cabinet and is not designed to bolt directly to it.

6.3 Non-Standard Batteries

When batteries other than a matching Battery Cabinet are used (not recommended), a remote battery disconnect switch with overcurrent protection is required per the National Electrical Code. Refer to **Figure 39** and **Figure 40**. Contact your Liebert sales representative.

1. Install battery racks/cabinets and batteries per manufacturer's installation and maintenance instructions.
2. Verify battery area has adequate ventilation and battery operating temperature complies with manufacturer's specification.

If you have any questions concerning batteries, battery racks, or accessories, contact Liebert Global Services at **1-800-543-2378**.

7.0 CONFIGURING YOUR GROUND AND NEUTRAL CONNECTIONS

Improper grounding is the largest single cause of UPS installation and start-up problems. This is not an easy subject, since grounding techniques vary significantly from site to site, depending on several factors. The questions you should ask are:

- What is the configuration of the input power source? Most of the recommended schemes for UPS grounding require grounded-wye service. The UPS system requires a bypass neutral for sensing and monitoring the quality of the bypass input. If the building service is ungrounded delta or corner-grounded delta, contact your Liebert representative to ensure your system
- What is the configuration of the UPS equipment? A Power-Tie system has different needs than a standalone UPS module.
- What is the connected load? Does the critical load consist of one or more Power Distribution Units (PDUs)? Do the PDUs have isolation transformers?

The following sections discuss recommended grounding procedures for various system configurations.



NOTE

Some UPS modules are equipped with input isolation transformers. However, these transformers have no effect upon any system grounding considerations. These modules will be grounded exactly as shown in the following examples.

7.1 Preferred Grounding Configuration, 480 or 600 VAC Input and Output, Isolated Power Distribution Units, Wye-Connected Service

Figure 1 Preferred Grounding Configuration, 480 or 600 VAC input and output

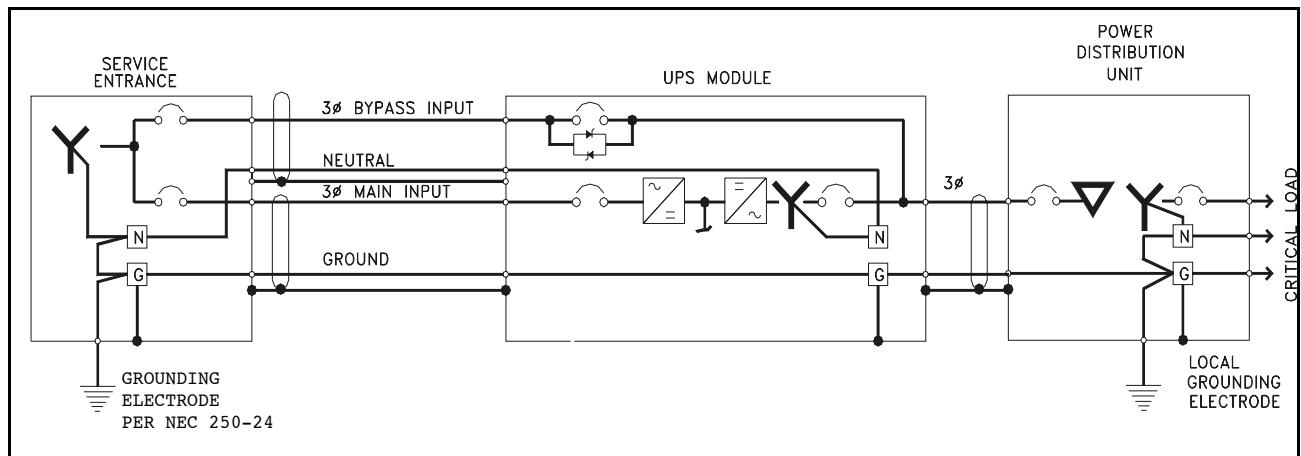

One of the most-common configurations of the Series 600T UPS is the Single Module System with 480 VAC input, 480 VAC output, and a connected load consisting of multiple Power Distribution Units (PDUs) with isolation transformers in the PDUs to produce 208 VAC. For Canadian customers, the UPS modules usually have 600 VAC input and output. The same principles apply if the connected load is an isolation transformer feeding various loads. Figure 1 above shows a typical installation.

Notice that the UPS module main input and bypass input are connected to a grounded-wye service. In this configuration, the UPS module is not considered a separately derived source. The UPS module output neutral is solidly connected to the building service neutral, which is bonded to the grounding conductor at the service entrance equipment

The isolation transformers in the PDUs are considered a separately derived source. Therefore the PDU neutral should be bonded to the PDU grounding conductor and connected to a local grounding electrode in compliance with NEC 250-26.

Advantages of this configuration include:

- A measure of common-mode noise attenuation, since the isolation (common-mode rejection) occurs as close to the load as practical (i.e. at the PDU).
- The UPS module can be located remotely from the PDU without compromising common-mode noise performance.
- By using UPS modules with 480 VAC input and output and creating 208 VAC at the PDU, smaller and less costly power feeders can be used and less voltage drop (as a percent of nominal) occurs.



NOTE

Some UPS modules are equipped with input isolation transformers. However, these transformers have no effect upon any system grounding considerations. These modules will be grounded exactly as shown in these pages.

7.2 Alternative Grounding Configuration, 480 or 600 VAC Input and Output, Isolated Power Distribution Units, Wye-Connected Service

Figure 2 Alternative Grounding Configuration, 480 or 600 VAC input and output

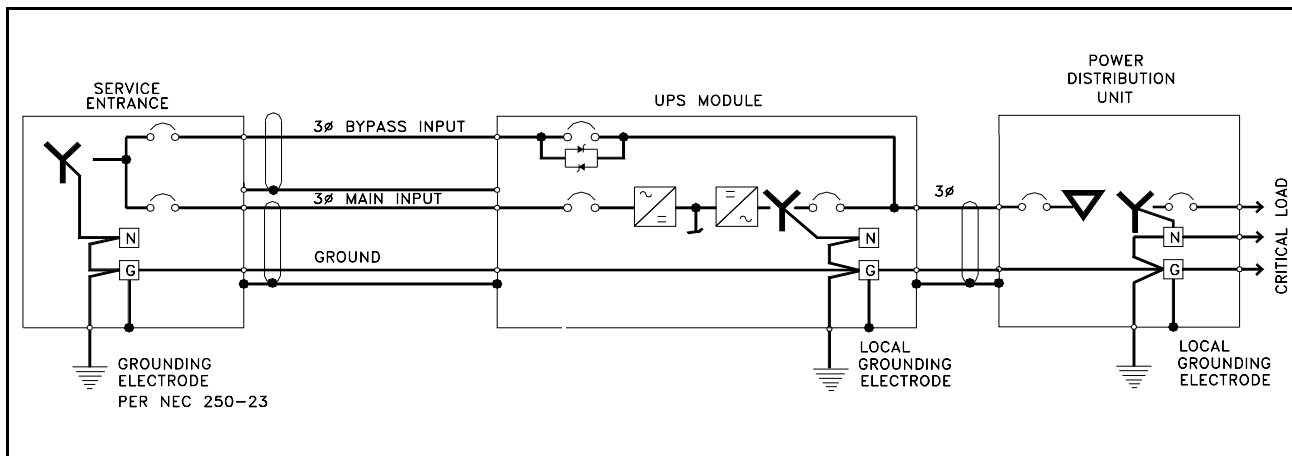

This configuration is similar to that shown in Section 7.1, except that the service entrance neutral is not brought into the UPS module. In this configuration, the UPS output transformer is considered a separately derived source. The UPS module neutral is bonded to the UPS ground, which is connected to a local grounding electrode in accordance with NEC 250-26.

Please note that this configuration represents a price/performance trade-off. Whenever the UPS module transfers to or from bypass, two AC sources (input and bypass) are briefly connected together and circulating current must flow. In the previous configuration, the current flows through the neutral conductor. In this configuration, the current flows through the ground path, possibly tripping ground fault interruptors (GFIs) and distorting the bypass waveform reference. Proper adjustment of ground fault interruptors is necessary to avoid unwanted tripping.

This configuration is reserved for those applications which meet all the following criteria:

- The facility has Wye-connected service
- The module rectifier input and bypass input are fed from the same source
- The connected load is strictly 3-wire (such as one or more PDUs) and does not require a neutral from the UPS
- Special precautions are taken to prevent tripping the ground fault interruptors. The time delay should be set to at least 30 cycles to prevent tripping when the UPS performs a transfer or retransfer operation.



CAUTION

Failure to properly set the ground fault interruptors could cause loss of power to the critical load.

7.3 Grounding Configuration, 480 or 600 VAC Input and Output, Delta Source or Impedance-Grounded Wye

Figure 3 Preferred Grounding Configuration with Ungrounded Delta Source Input (top) and Corner-Grounded Delta (bottom)

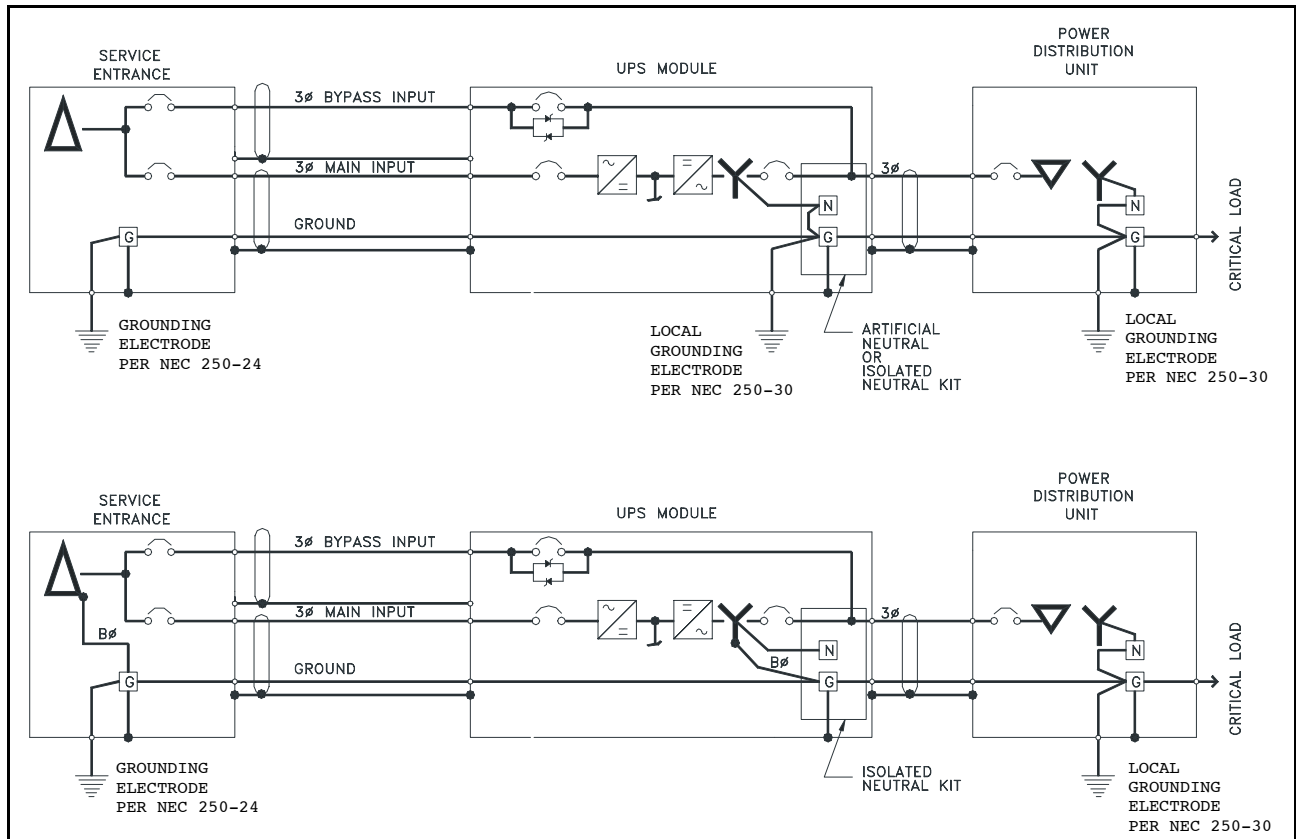

As previously mentioned, Series 600T UPS modules require a bypass input neutral for sensing and monitoring. With a wye-connected input source, the installer should connect the building service neutral to the module output neutral to achieve this. When the building service is delta-connected, however, the installer must take special steps to ensure reliable UPS functioning.

If building service is ungrounded delta (and there is no intent to operate with one corner of the delta grounded, either on purpose or accidentally), the UPS requires the Series 600T Artificial Neutral Kit for proper operation. This kit uses a resistor network to create a reference point for the bypass input. In this case, the UPS output neutral *must* be bonded to the UPS ground. See Figure 5 above.

If the building service is corner-grounded delta or an impedance-grounded wye, the UPS requires the Series 600T Isolated Neutral Kit. This kit uses control isolation transformers to create a reference point. For this application, the UPS output neutral *must not* be bonded to the UPS ground.

7.4 Preferred Grounding Configuration, 480 or 600 VAC Input and Output, with Power-Tie™ Switchgear

Figure 4 Preferred Grounding Configuration, Power-Tie™ Systems

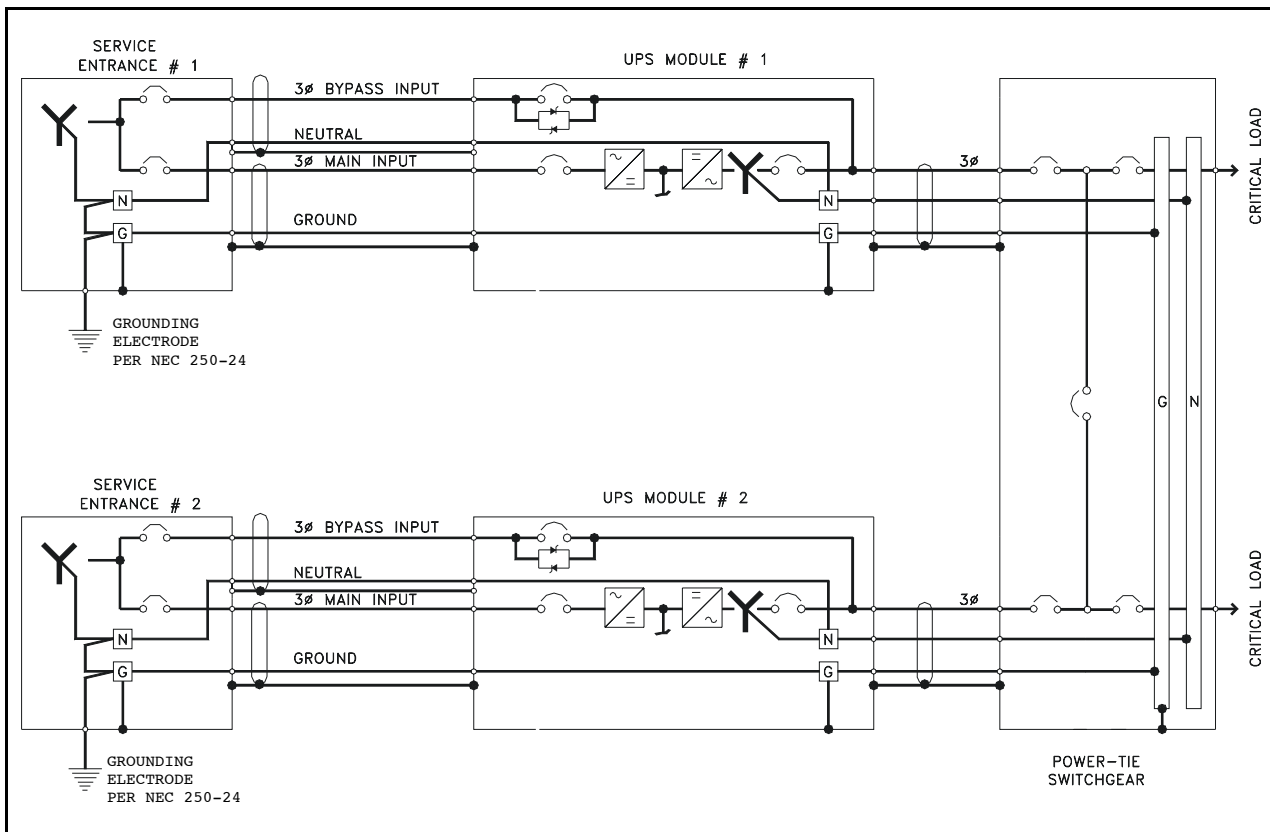

Single Module Systems can be used with Power-Tie switchgear to provide dual critical load buses. The Power-Tie switchgear permits transferring critical loads from one critical bus to the other so that one UPS module and associated breakers can be de-energized for maintenance. Certain configurations of Power-Tie equipment also permit the operator to continuously parallel the output of the UPS modules.

In tied systems, each UPS module must have its neutral solidly connected to its own building service neutral and to the Power-Tie switchgear neutral. See Figure 6 above.



NOTE

It is essential to run a neutral connection between the tie switchgear and both UPS modules as shown in the illustration above.

7.5 Preferred Grounding Configuration, Battery Systems

Figure 5 Preferred Battery Cabinet Grounding Configuration

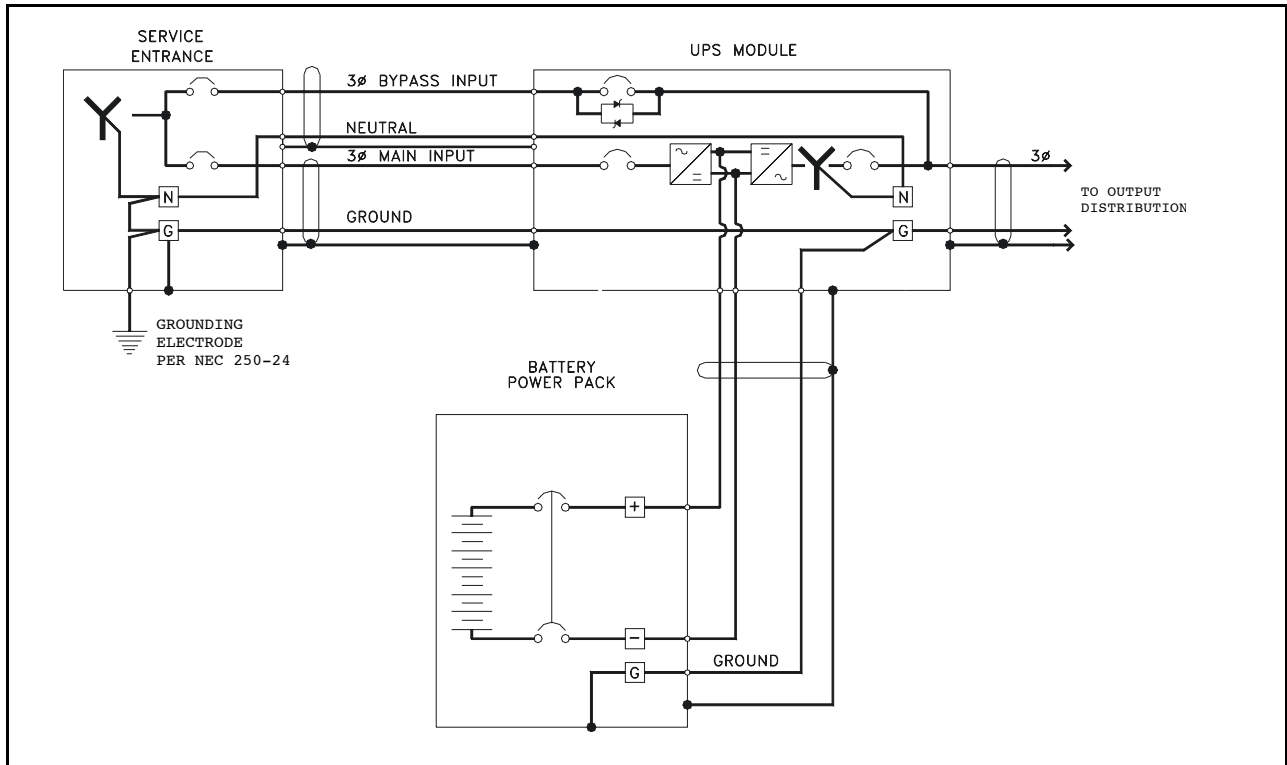

Large, open-rack battery systems are normally either locally grounded or left ungrounded, depending on local code requirements.

Battery cabinet systems, on the other hand, should be grounded to the UPS ground bus bar. Figure 7 above illustrates how a simple one-cabinet system would be grounded. For systems with multiple cabinets, the same configuration would apply. However, for simplicity the installer can connect all the battery cabinet grounds together and run a single ground conductor (in the same conduit as the phase conductors) to the UPS ground.

8.0 WIRING CONSIDERATIONS



WARNING

ALL POWER CONNECTIONS MUST BE COMPLETED BY A LICENSED ELECTRICIAN THAT IS EXPERIENCED IN WIRING THIS TYPE OF EQUIPMENT. WIRING MUST BE INSTALLED IN ACCORDANCE WITH ALL APPLICABLE NATIONAL AND LOCAL ELECTRICAL CODES. IMPROPER WIRING MAY CAUSE DAMAGE TO THE EQUIPMENT OR INJURY TO PERSONNEL.

VERIFY THAT ALL INCOMING HIGH AND LOW VOLTAGE POWER CIRCUITS ARE DE-ENERGIZED AND LOCKED OUT BEFORE INSTALLING CABLES OR MAKING ANY ELECTRICAL CONNECTIONS.

Refer to **Appendix A - Site Planning Data** and installation drawings in **Figure 7** through **Figure 42**. Determine AC currents for your system (kVA, voltage, and options). Also refer to equipment nameplate for the model number, rating, and voltage. For wire termination data, refer to **Table 1** and **Appendix B - Field Supplied Lugs**.



NOTE

*Use 75°C copper wire. Select wire size based on the ampacities in **Table 3** of this manual, a reprint of **Table 310-16** and associated notes of the **National Electrical Code (NFPA 70)**.*



CAUTION

The weight of power cables must be adequately supported to avoid stress on bus bars and lugs. In addition to weight support, the following restraining method is recommended to control cable movement during external fault conditions: Wrap line cables together at 6 inches and 12 inches from the terminals with 5 wraps of 3/8 inch nylon rope or equivalent (tensile strength of 2000 pounds). Support remainder of cable with 5 wraps every 6 inches or 1 wrap every 1 inch.

8.1 Power and Control Wiring

1. Power wiring must be run in individual, separate conduit or cable tray. Control wiring must be stranded and run in individual separate steel conduit.



CAUTION

Power and control wiring must be separated!

2. Observe local, state and national electrical codes. Verify utility power and its overcurrent protection rating will accommodate the UPS input rating, including battery recharging.
3. A safety ground wire must be run from building ground to ground point in the UPS Module Cabinet and Battery Cabinet. The grounding conductor shall comply with the following conditions of installation:
 - a. An insulated grounding conductor that is green with or without one or more yellow stripes is to be installed as part of the branch circuit that supplies the unit or system. The grounding conductor should be sized in accordance with NEC and local codes.
 - b. The grounding conductor described above is to be grounded to earth at the service equipment or, if supplied by a separately derived system, at the supply transformer or motor-generator set.
 - c. The attachment-plug receptacles in the vicinity of the unit or system are all to be of a grounding type, and the grounding conductors serving these receptacles are to be connected to earth ground at the service equipment.
4. When possible, input to the UPS and bypass should be four wire plus ground. When input is straight delta, the UPS artificial neutral kit should be ordered. When input is corner-grounded delta, the isolated neutral kit should be ordered.
5. Observe clockwise phase rotation of all power wiring. Phase A leads Phase B leads Phase C. A qualified electrician should check the phase rotation.
6. NEC Class 1 wiring methods are required for control and communication Class 2 circuits.

8.2 Battery Wiring

Power wiring to the Battery Cabinet connects positive, negative, and ground power cables from the Battery Cabinet to the associated UPS. Connection of the UPS to the Battery Cabinet serves to both charge and discharge the batteries (when needed). The battery disconnect (circuit breaker) requires a control cable. Power and control cables are field supplied. Refer to **Figure 11** through **Figure 13**.



WARNING

A BATTERY INTERCELL CONNECTION ON EACH TIER IS DISCONNECTED FOR SAFETY DURING SHIPMENT. DO NOT COMPLETE THESE CONNECTIONS. THE LIEBERT CUSTOMER SERVICE REPRESENTATIVE WILL COMPLETE THESE CONNECTIONS AS PART OF START-UP. AN IMPROPERLY INSTALLED UNIT CAN RESULT IN INJURY TO PERSONNEL OR DAMAGE TO EQUIPMENT.



CAUTION

Be sure polarity is correct when wiring the Battery Cabinet to the connected equipment (positive to positive; negative to negative). If polarity is not correct, fuse failures or equipment damage can result.

Call Liebert Global Services to schedule installation check-out, final battery intercell connections, and start-up.



NOTE

Inspection of the battery installation is a service that can be provided by Liebert. A Battery Specialist can perform a detailed inspection of the entire battery system to ensure it meets current IEEE standards. This inspection service is recommended because batteries are a very critical part of the UPS system.

Figure 6 Typical Power Wiring

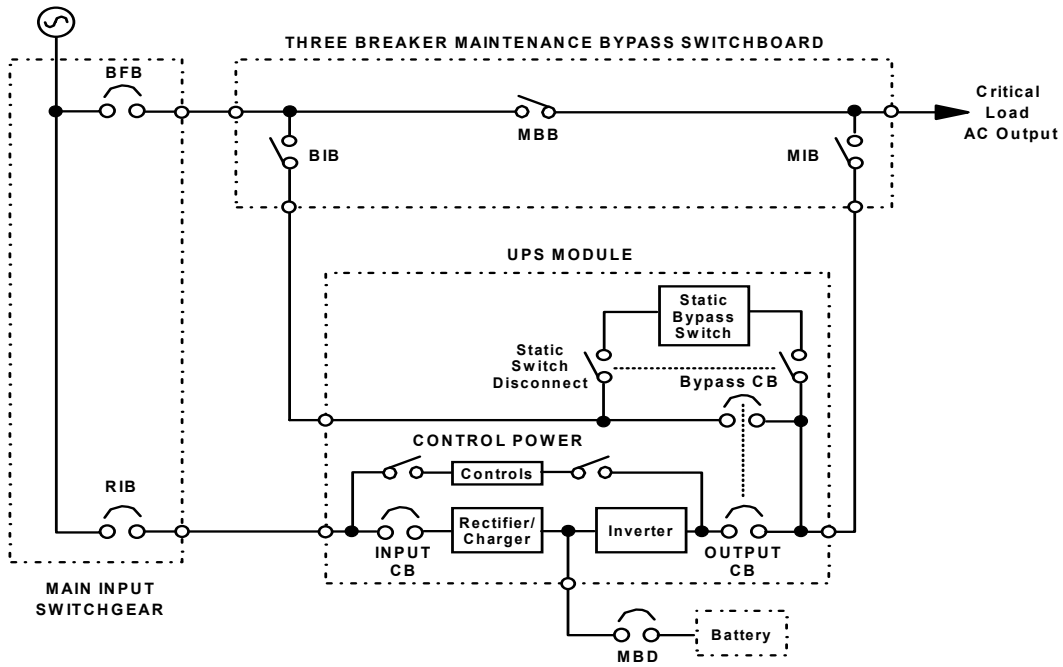

Abbreviations for Circuit Breakers	
BFB	Bypass Feeder Breaker
BIB	Bypass Input Breaker
MBB	Maintenance Bypass Breaker
MBD	Module Battery Disconnect
MBFB	Maintenance Bypass Feeder Breaker
MIB	Maintenance Isolation Breaker
RIB	Rectifier Input Breaker

9.0 WIRING CONNECTIONS



WARNING

VERIFY THAT ALL INCOMING HIGH AND LOW VOLTAGE POWER CIRCUITS ARE DE-ENERGIZED AND LOCKED OUT BEFORE INSTALLING CABLES OR MAKING ELECTRICAL CONNECTIONS.

ALL POWER CONNECTIONS MUST BE COMPLETED BY A LICENSED ELECTRICIAN EXPERIENCED IN WIRING UPS EQUIPMENT, AND IN ACCORDANCE WITH ALL APPLICABLE NATIONAL AND LOCAL ELECTRICAL CODES.

IMPROPER WIRING MAY CAUSE DAMAGE TO THE UPS OR INJURY TO PERSONNEL.



CAUTION

All shielded cables, non-shielded cables, non-shielded control wires, non-shielded battery breaker control wires, and non-shielded remote control wires must be housed in individual, separate, steel conduits. Placing multiple cables in the same conduit with other control or power wiring may cause system failure.

Refer to the drawings in this manual and any other drawings provided by Liebert for this installation. Make all of the following connections:

1. AC power cables from input power source circuit breaker (RIB) to UPS Module Input. Observe phase rotation.



CAUTION

If there are line-to-neutral loads connected to the UPS output, the input source must be wye connected and have three phases plus neutral plus ground. If the specified input is not available, an isolation transformer is required.

2. AC power cables from bypass power source circuit breaker (BIB) to UPS Module Bypass input. Observe phase rotation.
3. AC power cables from UPS Module Output to critical load. Observe phase rotation.



NOTE

If your installation includes a Maintenance Bypass Panelboard or a Transformer Cabinet, some (or all) power cables will be terminated in these cabinet(s). Make sure all required wiring between UPS module and the optional cabinet(s) is completed. Observe phase rotation.

-
- The UPS Module Output Neutral is connected to one common point and solidly grounded per requirements of the National Electrical Code. The ground connection inside the UPS cabinet may be required by the power wiring configuration at your site.



CAUTION

UPS bypass and output neutral must be connected to only one common point in the UPS. This neutral line must be grounded at the source.

- For Battery Cabinets:

DC power cables (and ground) from Battery Cabinet to UPS Module, and between Battery Cabinets. Observe polarity.



NOTE

DC power and battery circuit breaker control cables are provided with the matching Battery Cabinet.



WARNING

DO NOT MAKE ANY CONNECTIONS BETWEEN BATTERY TIERS IN THE BATTERY CABINET. THESE CONNECTIONS WILL BE MADE BY THE LIEBERT CUSTOMER SERVICE REPRESENTATIVE DURING START-UP.

- For remote battery:

DC power cables (and ground) from battery to Module Battery Disconnect, and then to UPS Module DC bus. Observe polarity.

- Module Battery Disconnect control wiring to UPS Module, and between Battery Cabinets.
- Control wiring to Remote Monitor Panel, if used. Selected alarm messages are also available for customer use through a set of contacts on a separate terminal board. Wiring must be run in individual separate steel conduit.
- Emergency Power Off control wiring must be run in separate steel conduit.
- Communications wiring for site monitoring or for modem must be run in separate steel conduit.
- Power and control connections required for the Maintenance Bypass.
- Any additional special wiring required at your site.

10.0 WIRING INSPECTION

1. Verify all power connections are tight.
2. Verify all control wire terminations are tight.
3. Verify all power wires and connections have proper spacing between exposed surfaces, phase-to-phase and phase-to-ground.
4. Verify that all control wires are run in individual, separate, steel conduit.

Table 1 Power Wiring Terminals - Factory Supplied

UPS Module Rating kVA	Connection Type
500-750 kVA	<p>Bus bars for connecting hardware (with 3/8" holes on 1.75" centers) are provided for bypass input, critical load output and DC wiring terminations. DC bus bars for 625-750 kVA modules are designed for top entry and are located adjacent to the input circuit breaker. Rectifier input wiring is top-entry, directly to lugs on top of the input circuit breaker. Field-supplied lugs are required.</p> <p>EXCEPTION: 500 kVA UPS modules with the 6-pulse rectifier and no input isolation transformer have rectifier input bus bars exactly like those described above for bypass and critical load termination.</p>

Use 75°C copper wire. Select wire size based on the ampacities in **Table 310-16** (see **Table 3** of this manual) and associated notes of the National Electrical Code (NFPA 70).

Use commercially available solderless lugs for the wire size required for your application. Refer to **Appendix B - Field Supplied Lugs**. Connect wire to the lug using tool and procedure specified by the lug manufacturer.

Table 2 Torque Specifications

Nut and Bolt Combinations				
Bolt Shaft Size	Grade 2 Standard		Electrical Connections with Belleville Washers	
	Lb-in	N-m	Lb-in	N-m
1/4	53	6.0	46	5.2
5/16	107	12	60	6.8
3/8	192	22	95	11
1/2	428	48	256	29

Circuit Breakers With Compression Lugs (For Power Wiring)		
Cable Size or Range	Lb-in	N-m
#6 - #4	100	11
#3 - #1	125	14
1/0 - 2/0	150	17
3/0 - 200 MCM	200	23
250 - 400 MCM	250	28
500 - 700 MCM	300	34

Terminal Block Compression Lugs (For Control Wiring)		
AWG Wire Size or Range	Lb-in	N-m
#22 - #14	3.5 to 5.3	0.4 to 0.6

Use the values in this table unless the equipment is labeled with a different torque value.

Table 3 Table 310-16

Allowable Ampacities of Insulated Conductors Rated 0-2000 Volts, 60° to 90°C (140° to 194°F)¹

Not More than Three Conductors in Raceway or Cable or Earth (Directly Buried), based on Ambient Temperature of 30° (86°F)

Size	Temperature Rating of Conductor. See Table 310-13.						Size
	60°C (140°F)	75°C (167°F)	90°C (194°F)	60°C (140°F)	75°C (167°F)	90°C (194°F)	
	Types TW† UF†	Types FEPW†, RH,RHW†, THHW†, THW†, THWN†, XHHW†, USE†, ZW†	Types TBS, SA, SIS,FEP†, FEPB†,MI, RHH†, RHW-2 THHN†,THHW†, THW-2,THWN-2, USE-2, XHH, XHHW† XHHW-2,ZW-2	Types TW† UF†	Types RH†, RHW†, THHW†, THW†, THWN†, XHHW†, USE†	Types TBS, SA,SIS, THHN†, THHW†, THW-2, THWN-2, RHH†, RHW-2, USE-2, XHH, XHHW†, XHHW-2, ZW-2	
Copper			Aluminum or Copper-Clad Aluminum				
18	14
16	18
14	20†	20†	25†
12	25†	25†	30†	20†	20†	25†	12
10	30	35†	40†	25	30†	35†	10
8	40	50	55	30	40	45	8
6	55	65	75	40	50	60	6
4	70	85	95	55	65	75	4
3	85	100	110	65	75	85	3
2	95	115	130	75	90	100	2
1	110	130	150	85	100	115	1
1/0	125	150	170	100	120	135	1/0
2/0	145	175	195	115	135	150	2/0
3/0	165	200	225	130	155	175	3/0
4/0	195	230	260	150	180	205	4/0
250	215	255	290	170	205	230	250
300	240	285	320	190	230	255	300
350	260	310	350	210	250	280	350
400	280	335	380	225	270	305	400
500	320	380	430	260	310	350	500
600	355	420	475	285	340	385	600
700	385	460	520	310	375	420	700
750	400	475	535	320	385	435	750
800	410	490	555	330	395	450	800
900	435	520	585	355	425	480	900
1000	455	545	615	375	445	500	1000
1250	495	590	665	405	485	545	1250
1500	520	625	705	435	520	585	1500
1750	545	650	735	455	545	615	1750
2000	560	665	750	470	560	630	2000
Correction Factors							
Ambient Temp °C	For ambient temperatures other than 30°C (86°F), multiply the allowable ampacities shown above by the appropriate factor shown below.						Ambient Temp °F
21-25	1.08	1.05	1.04	1.08	1.05	1.04	70-77
26-30	1.00	1.00	1.00	1.00	1.00	1.00	78-86
31-35	.91	.94	.96	.91	.94	.96	87-95
36-40	.82	.88	.91	.82	.88	.91	96-104
41-45	.71	.82	.87	.71	.82	.87	105-113
46-50	.58	.75	.82	.58	.75	.82	114-122
51-55	.41	.67	.76	.41	.67	.76	123-131
56-6058	.7158	.71	132-140
61-7033	.5833	.58	141-158
71-804141	159-176

† Unless otherwise specifically permitted elsewhere in this Code, the overcurrent protection for conductor types marked with an obelisk (†) shall not exceed 15 amperes for No. 14, 20 amperes for No. 12, and 30 amperes for No. 10 copper; or 15 amperes for No. 12 and 25 amperes for No. 10 aluminum and copper-clad aluminum after any correction factors for ambient temperature and number of conductors have been applied.

¹ Reprinted with permission from NFPA 70-1993, the National Electrical Code®, Copyright 1996, National Fire Protection Association, Quincy, MA 02269. This reprinted material is not the complete and official position of the National Fire Protection Association, on the referenced subject which is represented only by the standard in its entirety.

11.0 INSTALLATION DRAWINGS

Figure 7 Outline Drawing, 500 kVA Single Module UPS, 6-Pulse Rectifier

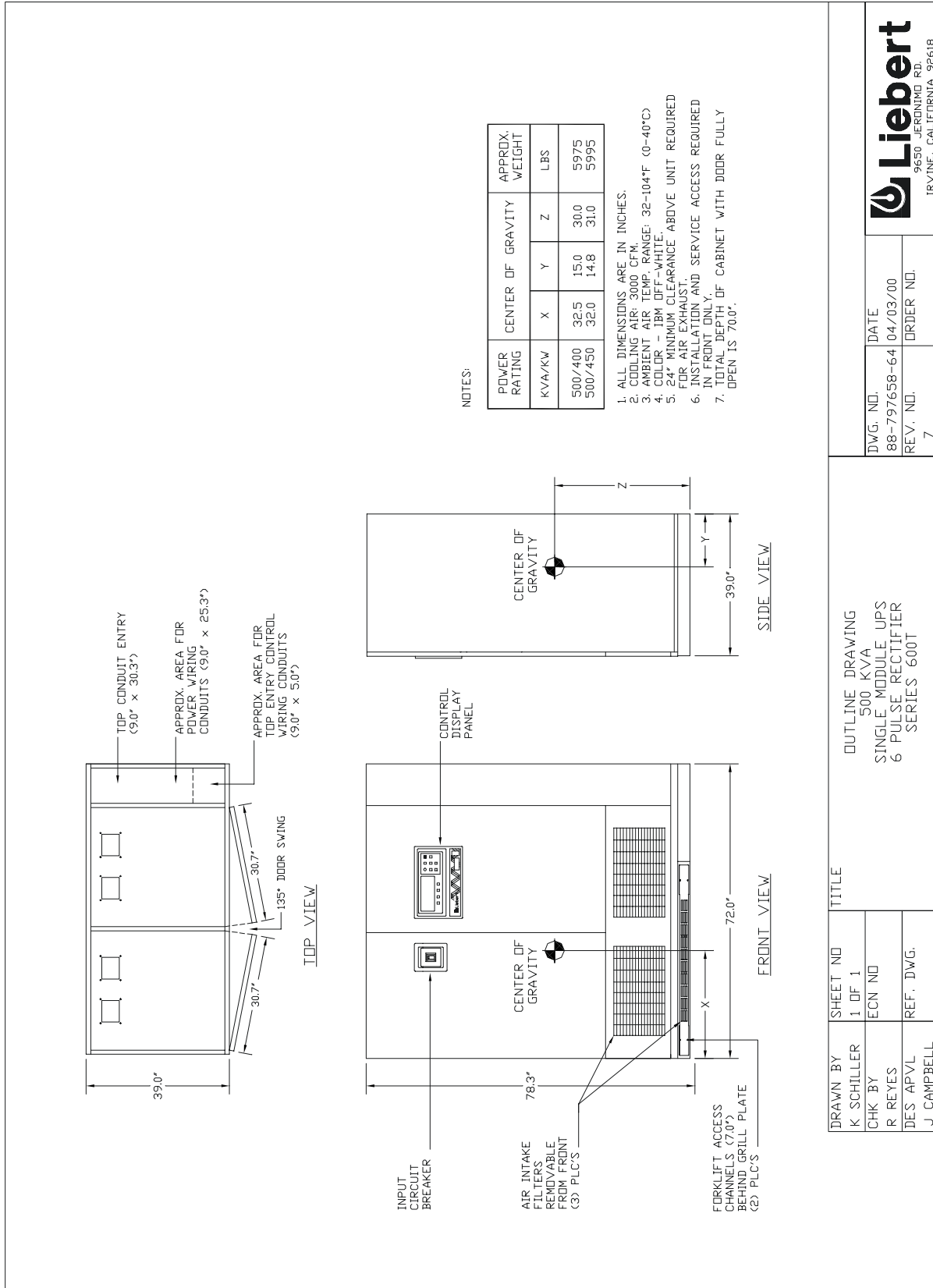

DRAWN BY K SCHILLER	SHEET NO 1 OF 1	TITLE OUTLINE DRAWING 500 KVA SINGLE MODULE UPS 6 PULSE RECTIFIER SERIES 600T	
CHK BY R REYES	ECN NO	DWG. NO. 88-797658-64	DATE 04/03/00
DES APVL J CAMPBELL	REF. DWG.	REV. NO. 7	ORDER NO.

FILE NAME: 88-797658-64-07.DWG

Libert
 9650 JERONIMO RD.
 IRVINE, CALIFORNIA 92618

Figure 8 Outline Drawing, 500 kVA Single Module UPS, 12-Pulse Rectifier

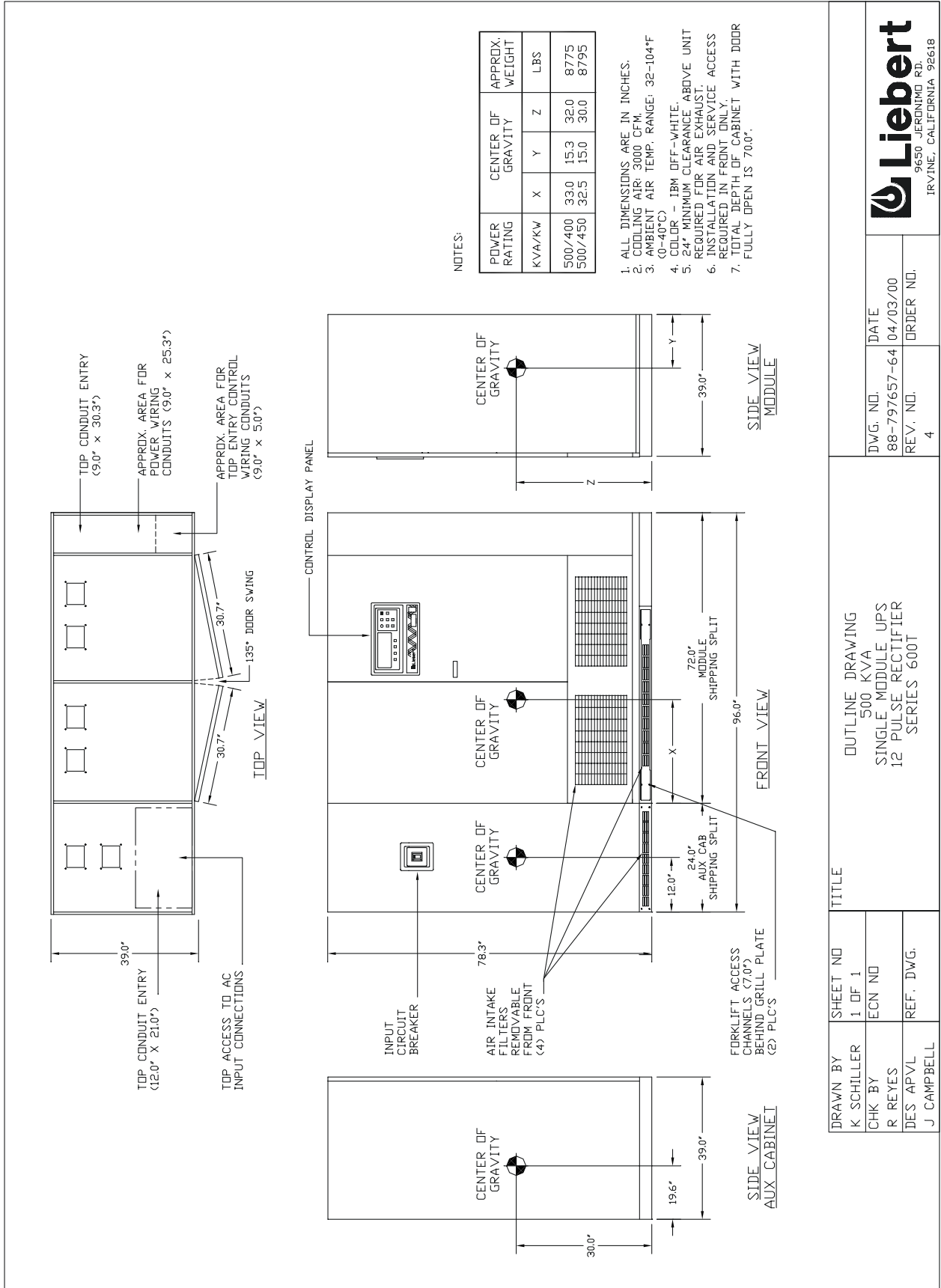

NOTES:

POWER RATING	CENTER OF GRAVITY			APPROX. WEIGHT
	X	Y	Z	
500/400	33.0	15.3	32.0	8775
500/450	32.5	15.0	30.0	8795

1. ALL DIMENSIONS ARE IN INCHES.
2. COOLING AIR: 3000 CFM.
3. AMBIENT AIR TEMP. RANGE: 32-104°F (0-40°C).
4. COLOR: IBM OFF-WHITE.
5. 24" MINIMUM CLEARANCE ABOVE UNIT REQUIRED FOR AIR EXHAUST.
6. INSTALLATION AND SERVICE ACCESS REQUIRED IN FRONT ONLY.
7. TOTAL DEPTH OF CABINET WITH DOOR FULLY OPEN IS 70.0".

DRAWN BY K SCHILLER		SHEET NO 1 OF 1	
CHK BY R REYES		ECN NO	
DES APVL J CAMPBELL		REF. DWG.	
DWG. NO. 88-797657-64		DATE 04/03/00	
REV. NO. 4		ORDER NO.	

TITLE

OUTLINE DRAWING
500 KVA
SINGLE MODULE UPS
12 PULSE RECTIFIER
SERIES 600T



FILE NAME: 88-797657-64-04.DWG

Figure 9 Outline Drawing, 625-750 kVA Single Module UPS, 6-Pulse Rectifier

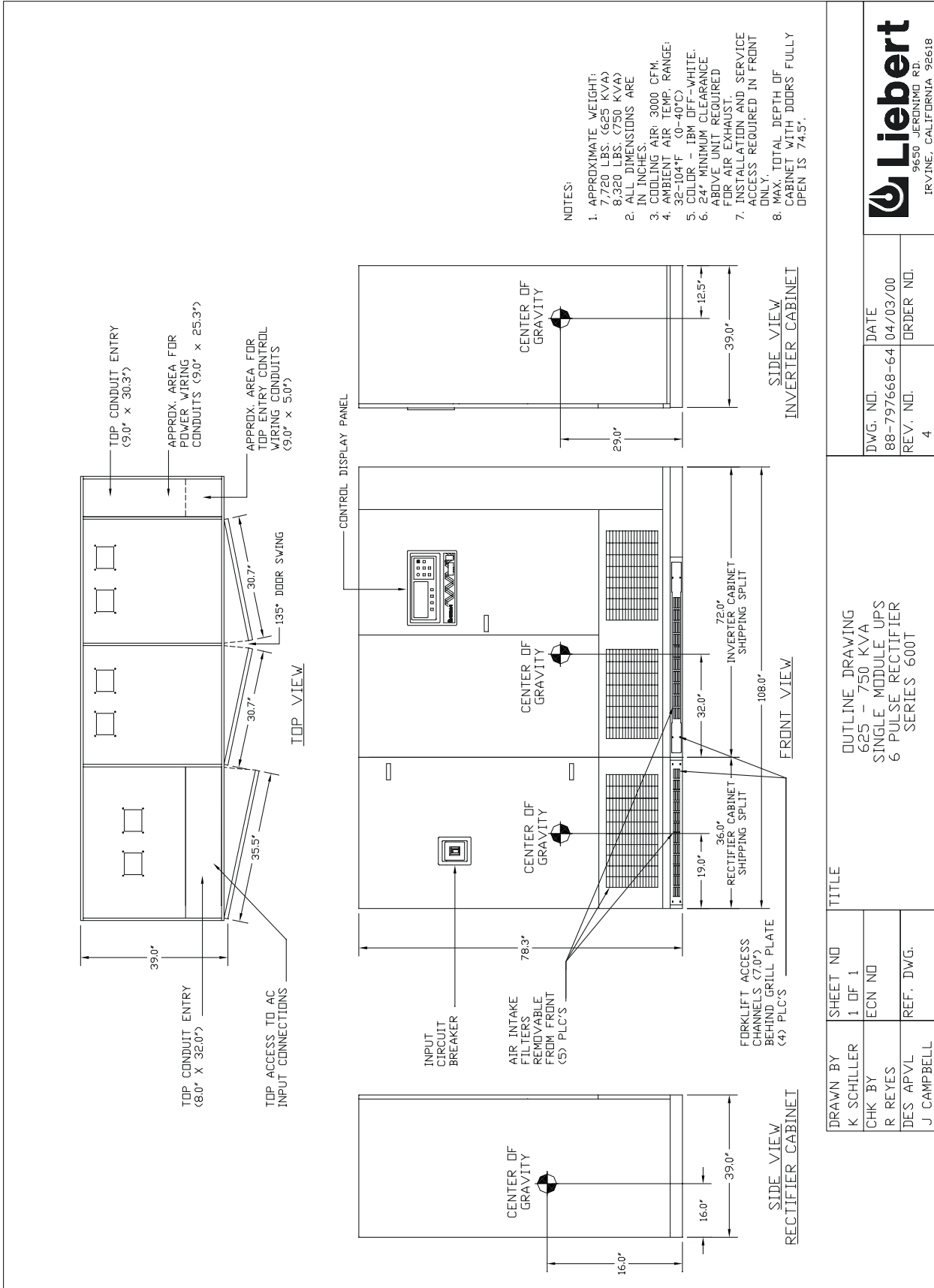

DWG. NO.		DATE	
88-797668-64		04/03/00	
REV. NO.		ORDER NO.	
4			

FILE NAME: 88-797668-64-04.DWG

TITLE

OUTLINE DRAWING
625 - 750 KVA
SINGLE MODULE UPS
6 PULSE RECTIFIER
SERIES 600T

DRAWN BY	SHEET NO	TITLE	
K SCHILLER	1 OF 1	OUTLINE DRAWING 625 - 750 KVA SINGLE MODULE UPS 6 PULSE RECTIFIER SERIES 600T	
CHK BY	ECN NO		
R REYES			
DES APVL	REF. DWG.		
J CAMPBELL			



Figure 10 Outline Drawing, 625-750 kVA Single Module UPS, 12-Pulse Rectifier

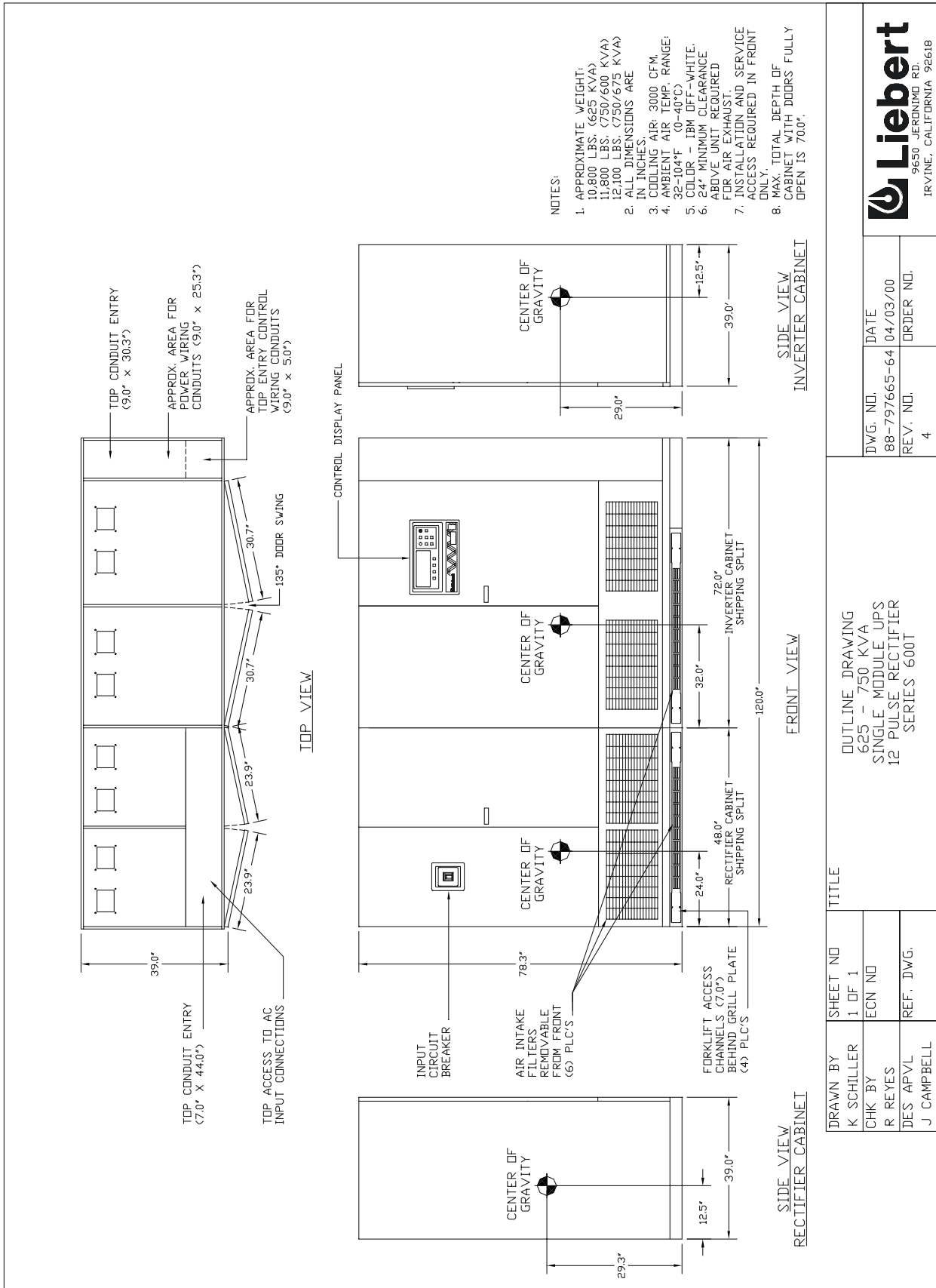

DWG. NO.	DATE
88-797665-64	04/03/00
REV. NO.	ORDER NO.
4	

FILE NAME: 88-797665-64-04.DWG

OUTLINE DRAWING
625 - 750 KVA
SINGLE MODULE UPS
12 PULSE RECTIFIER
SERIES 600T

TITLE	SHEET NO
	1 OF 1
DRAWN BY	ECN NO
K SCHILLER	
CHK BY	REF. DWG.
R REYES	
DES. APVL	
J CAMPBELL	

Figure 11 Battery Cabinet, Size A

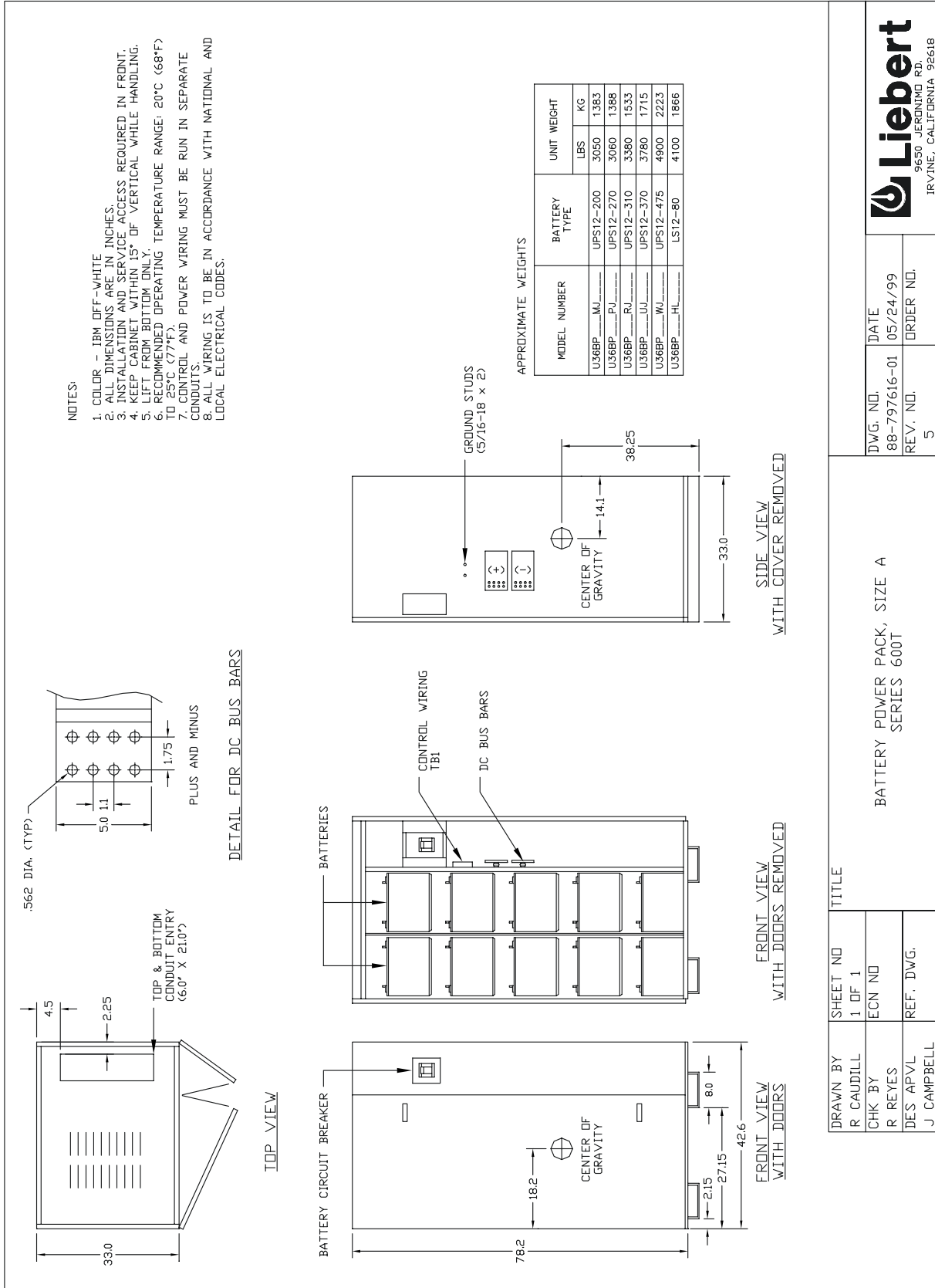

DRAWN BY R CAUDILL		SHEET NO 1 OF 1		TITLE BATTERY POWER PACK, SIZE A SERIES 600T	
CHK BY R REYES		ECN NO		DWG. NO. 88-797616-01	
DES APVL J CAMPBELL		REF. DWG.		DATE 05/24/99	
				ORDER NO.	
				5	
FILE NAME: 88-797616-01-05.DWG					



Figure 12 Battery Cabinet, Size B

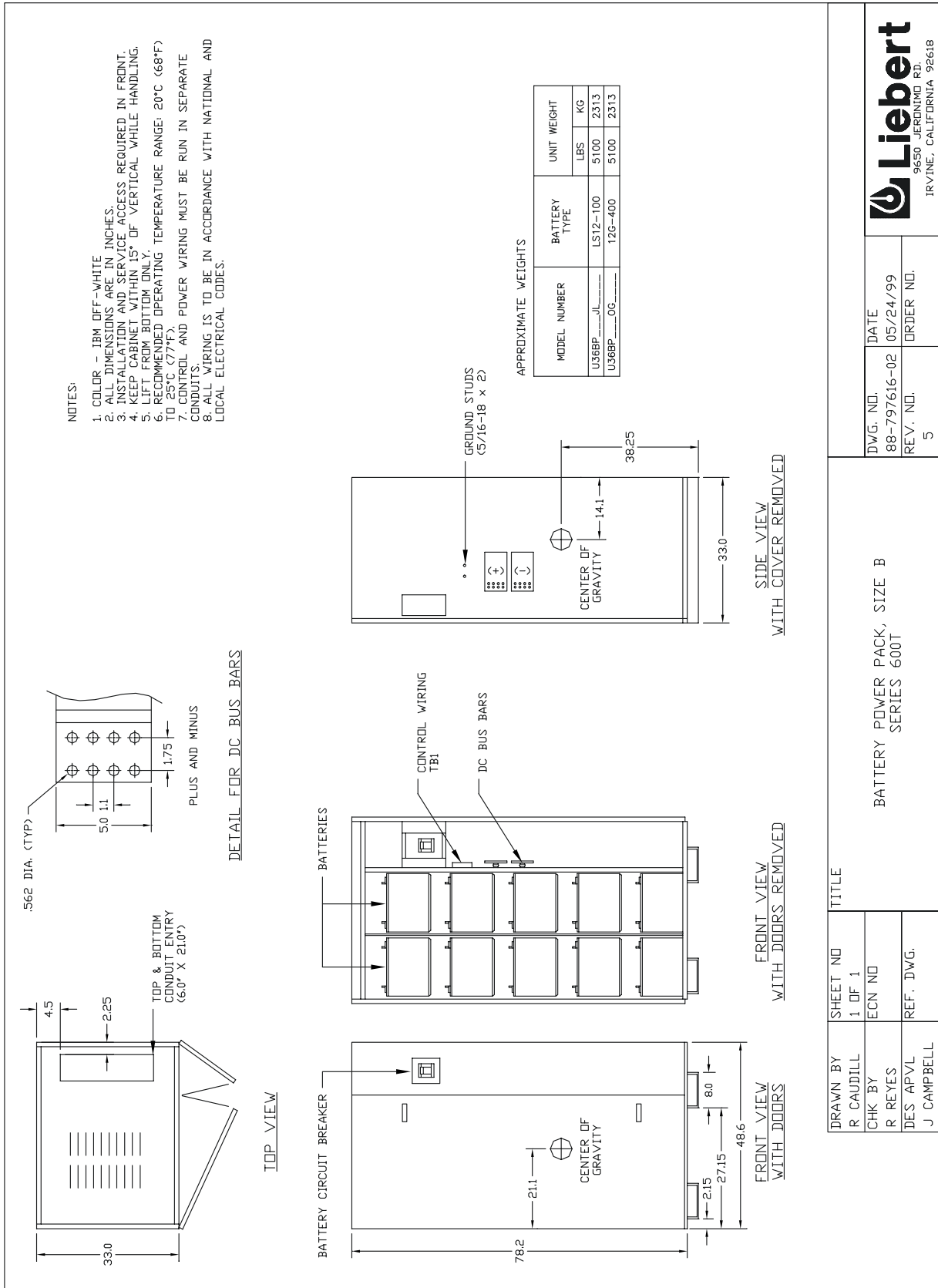
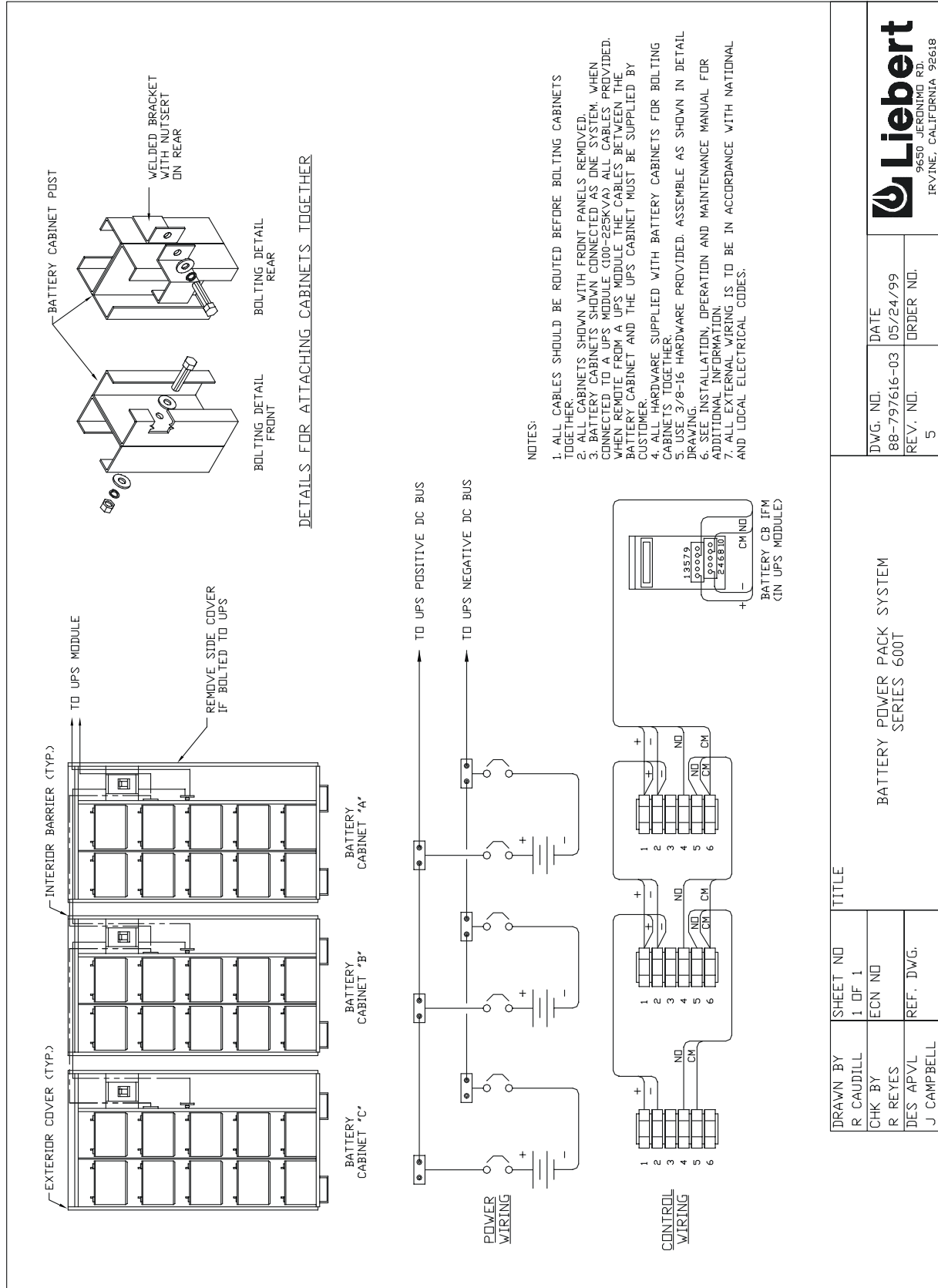

Figure 13 Parallel Battery Power Pack



DWG. NO.	DATE
88-797616-03	05/24/99
REV. NO.	ORDER NO.
5	

FILE NAME: 88-797616-03-03.DWG

TITLE	
BATTERY POWER PACK SYSTEM SERIES 600T	

DRAWN BY	SHEET NO
R CAUDILL	1 OF 1
CHK BY	ECN NO
R REYES	
DES' APVL	REF. DWG.
J CAMPBELL	

Figure 14 Base Mounting Patterns, 500 kVA SMS, 12-Pulse Rectifier

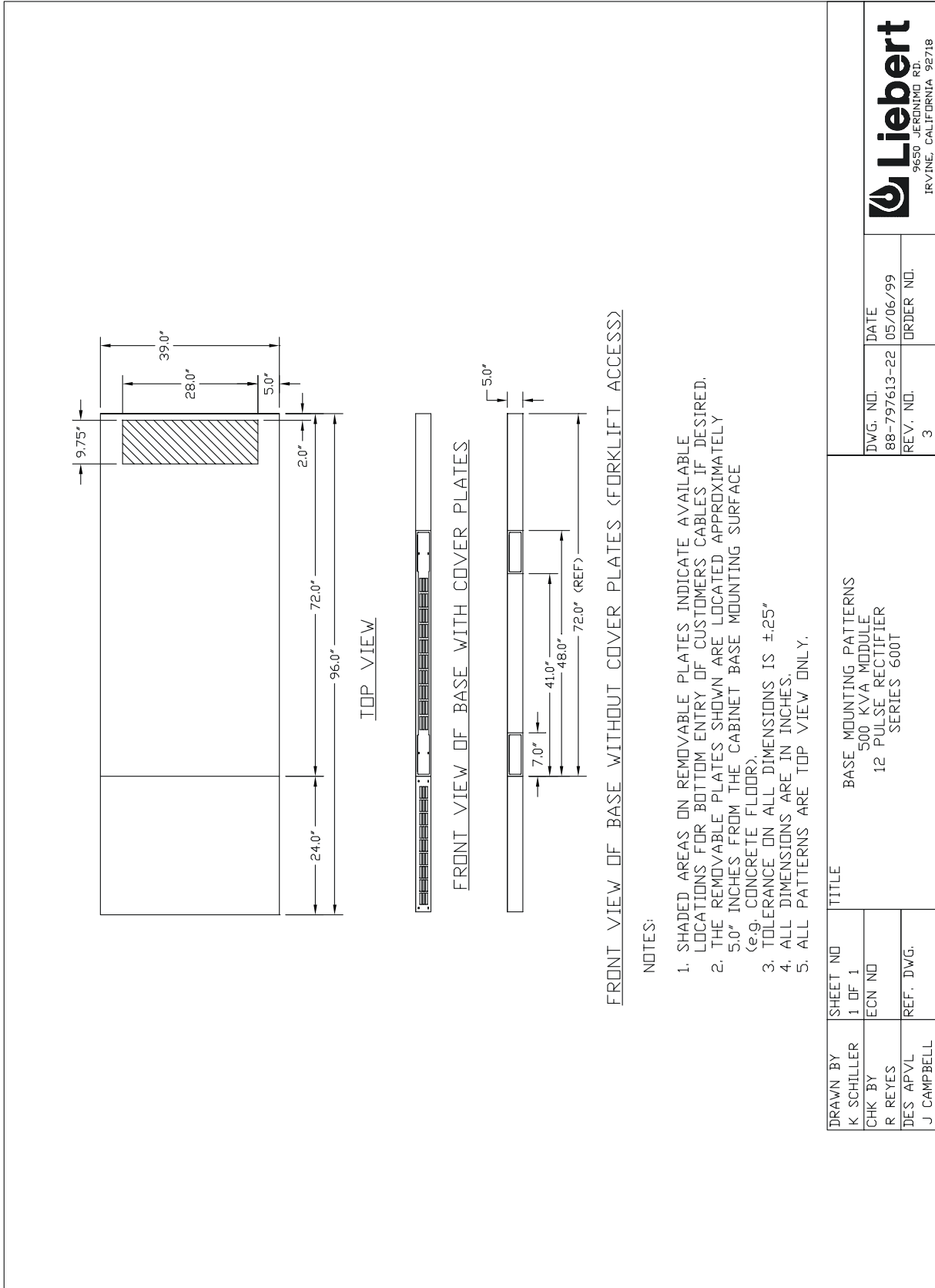

NOTES:

1. SHADED AREAS ON REMOVABLE PLATES INDICATE AVAILABLE LOCATIONS FOR BOTTOM ENTRY OF CUSTOMER CABLES IF DESIRED.
2. THE REMOVABLE PLATES SHOWN ARE LOCATED APPROXIMATELY 5.0" INCHES FROM THE CABINET BASE MOUNTING SURFACE (e.g. CONCRETE FLOOR).
3. TOLERANCE ON ALL DIMENSIONS IS $\pm .25"$
4. ALL DIMENSIONS ARE IN INCHES.
5. ALL PATTERNS ARE TOP VIEW ONLY.

DRAWN BY K SCHILLER		SHEET NO 1 OF 1		TITLE BASE MOUNTING PATTERNS 500 KVA MODULE 12 PULSE RECTIFIER SERIES 600T		DWG. NO. 88-797613-22		DATE 05/06/99	
CHK BY R REYES		ECN NO				REV. NO. 3		ORDER NO.	
DES APVL J CAMPBELL		REF. DWG.							



FILE NAME 88-797613-22-03.DWG

Figure 15 Base Mounting Patterns, 625-750 kVA SMS, 6-Pulse Rectifier

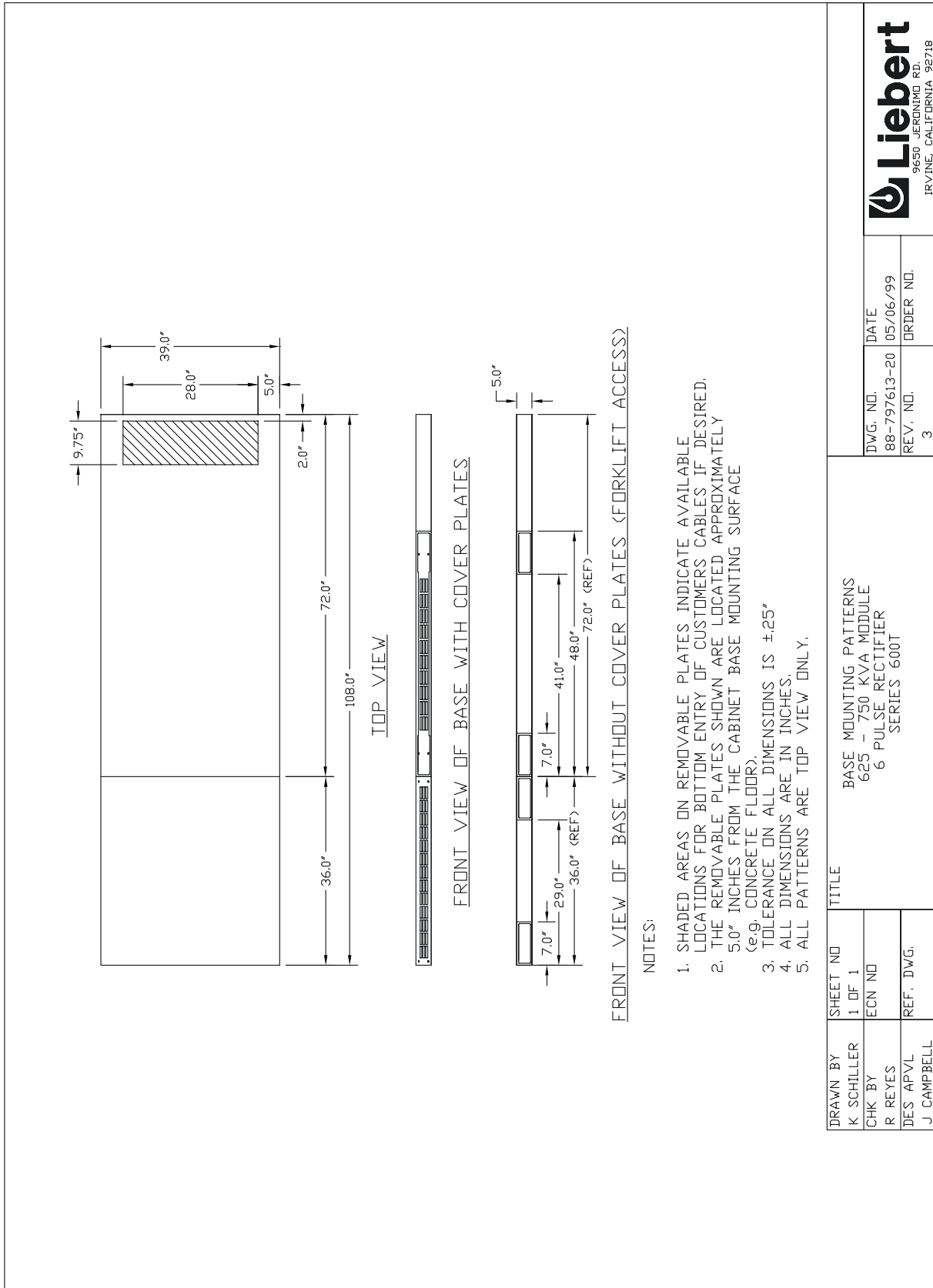

DRAWN BY K SCHILLER	SHEET NO 1 OF 1	TITLE BASE MOUNTING PATTERNS 625 - 750 KVA MODULE 6 PULSE RECTIFIER SERIES 600T	DWG. NO. 88-797613-20	DATE 05/06/99
CHK BY R REYES	ECN NO		REV. NO. 3	ORDER NO.
DES APVL J CAMPBELL	REF. DWG.		FILE NAME 88-797613-20-03.DWG	



Figure 16 Base Mounting Patterns, 625-750 kVA SMS, 12-Pulse Rectifier

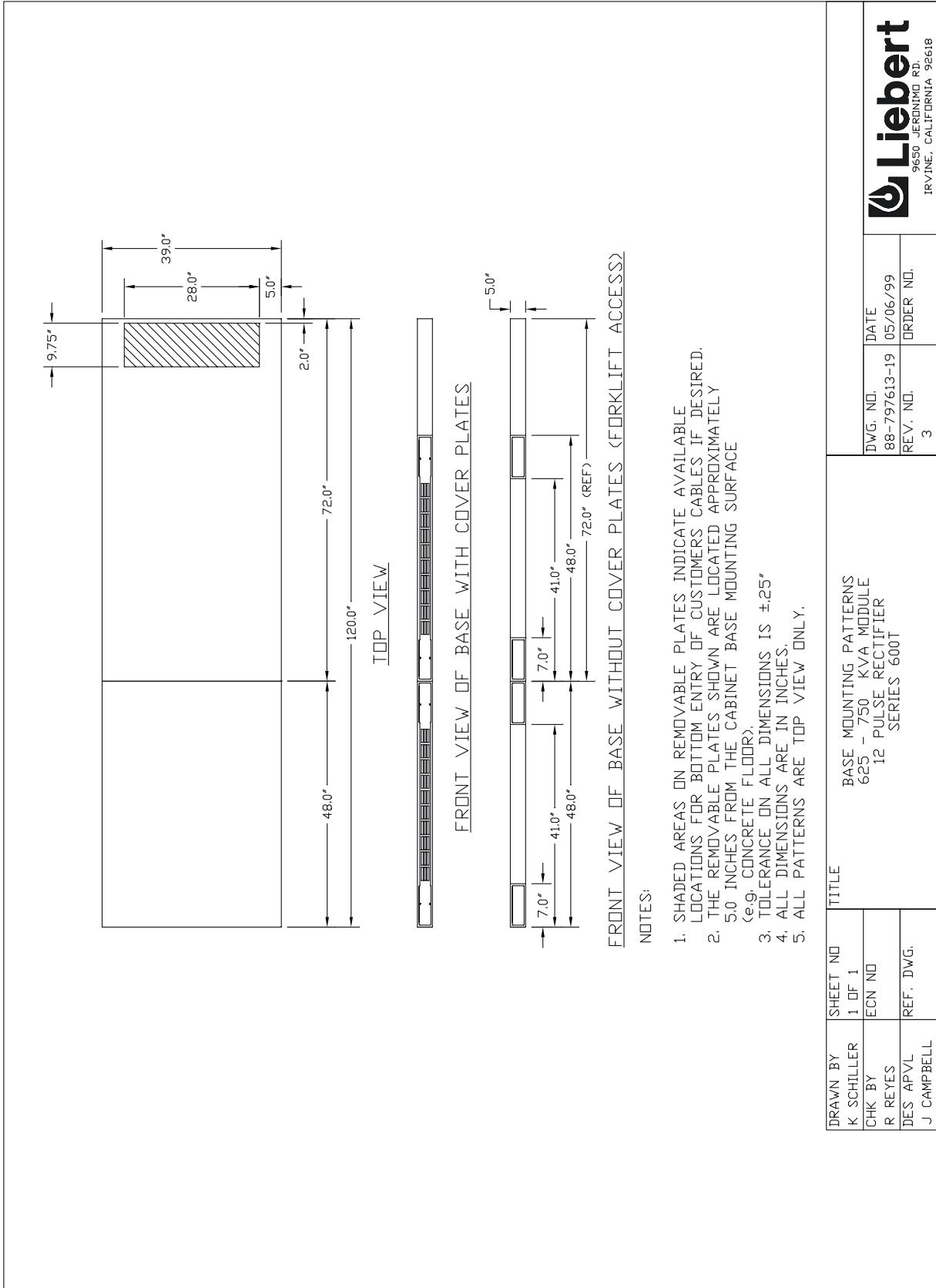

DRAWN BY	SHEET NO	TITLE
K SCHILLER	1 OF 1	BASE MOUNTING PATTERNS
CHK BY	ECN NO	625 - 750 KVA MODULE
R REYES		12 PULSE RECTIFIER
DES APVL	REF. DWG.	SERIES 600T
J CAMPBELL		

DWG. NO.	DATE
88-797613-19	05/06/99
REV. NO.	ORDER NO.
3	



Figure 17 Shipping Split Detail, 500 kVA SMS, 12-Pulse Rectifier

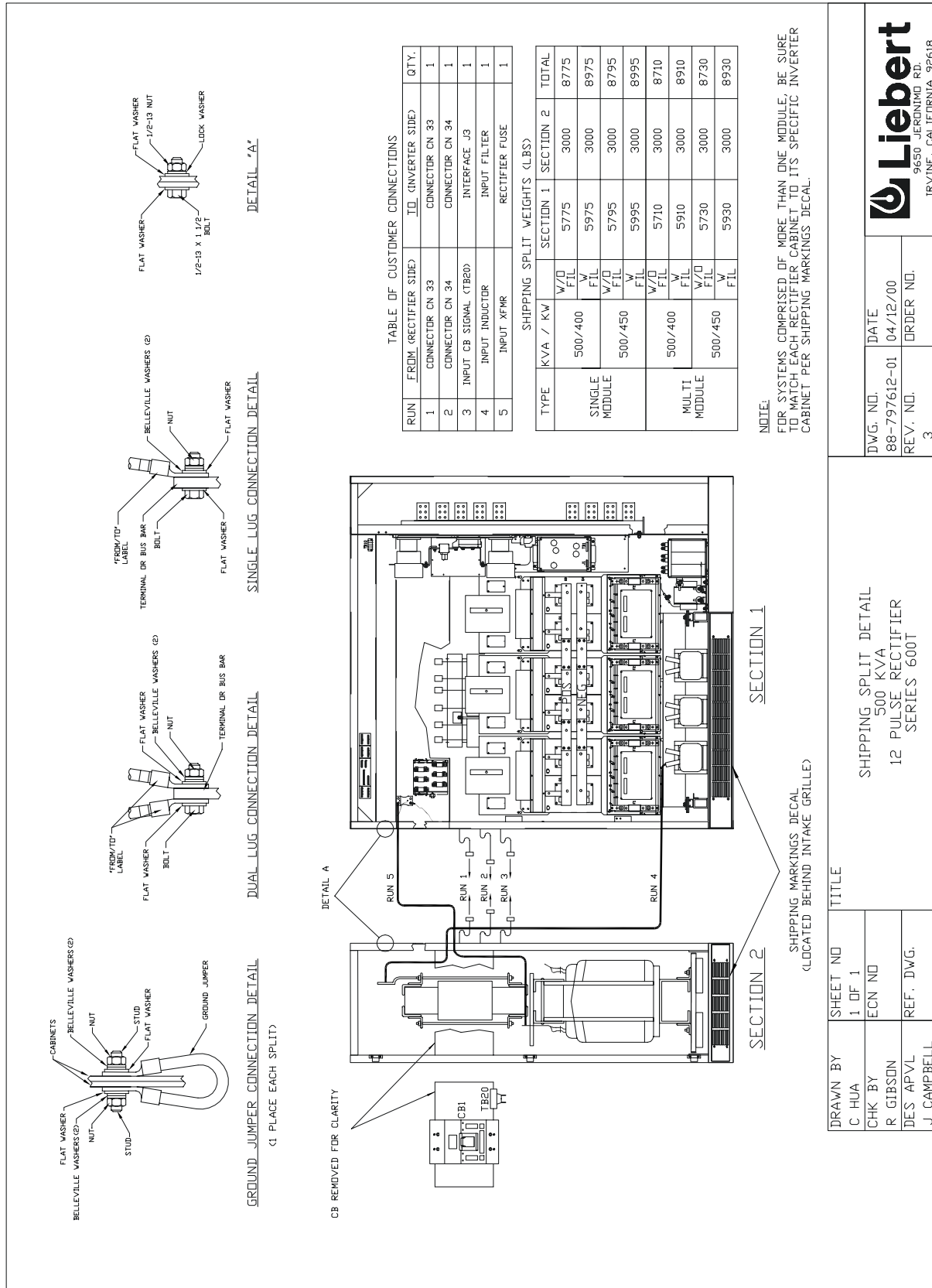
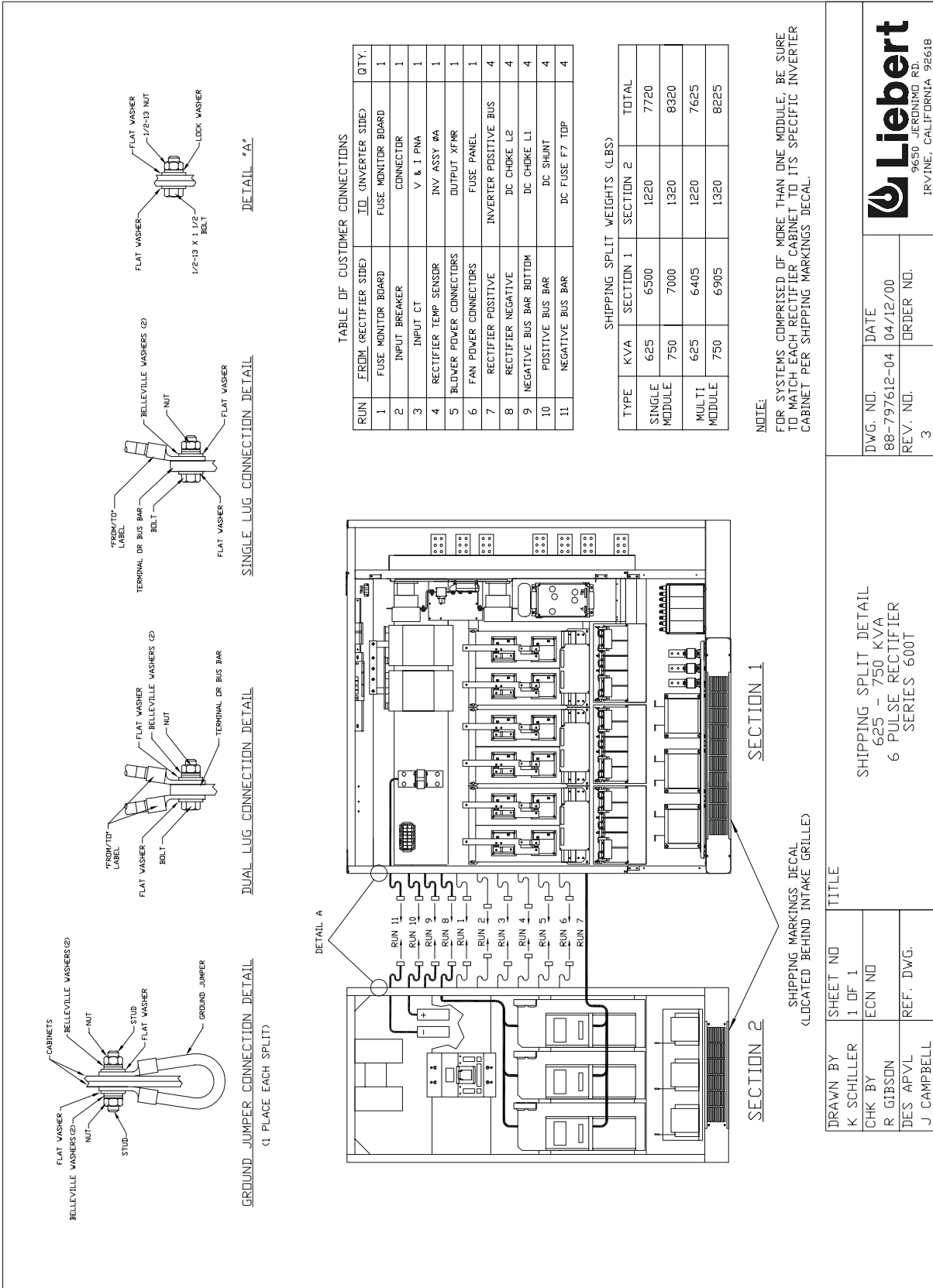
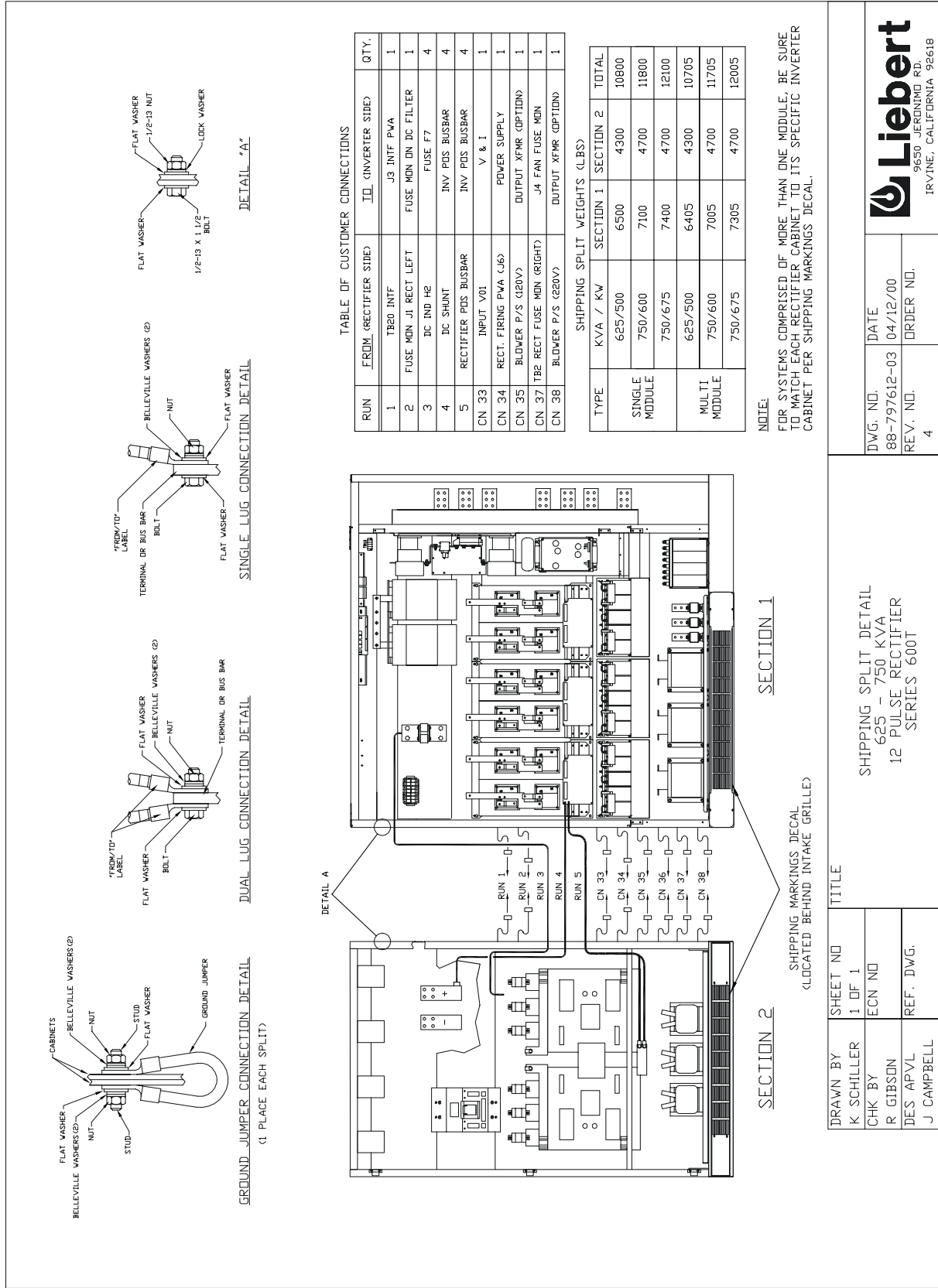

Figure 18 Shipping Split Detail, 625-750 kVA SMS, 6-Pulse Rectifier



DRAWN BY K SCHILLER		SHEET NO 1 OF 1		TITLE SHIPPING SPLIT DETAIL	
CHK BY R GIBSON		ECN NO		625 - 750 KVA	
DES APVL J CAMPBELL		REF. DWG.		6 PULSE RECTIFIER	
				SERIES 600T	
		DWG. NO. 88-797612-04		DATE 04/12/00	
		REV. NO. 3		ORDER NO.	
		FILE NAME: 88-797612-04-03.DWG		IRVINE, CALIFORNIA 92618	

Figure 19 Shipping Split Detail, 625-750 kVA SMS, 12-Pulse Rectifier



DWG. NO.	DATE
88-797612-03	04/12/00
REV. NO.	ORDER NO.
4	

FILE NAME: 88-797612-03-04.DWG

SHIPPING SPLIT DETAIL
625 - 750 KVA
12 PULSE RECTIFIER
SERIES 600T

DRAWN BY	SHEET NO	TITLE
K SCHILLER	1 OF 1	
CHK BY	ECN NO	
R GIBSON		
DES APVL	REF. DWG.	
J CAMPBELL		



Figure 20 Bussing Details, 500 kVA SMS, 6-Pulse Rectifier

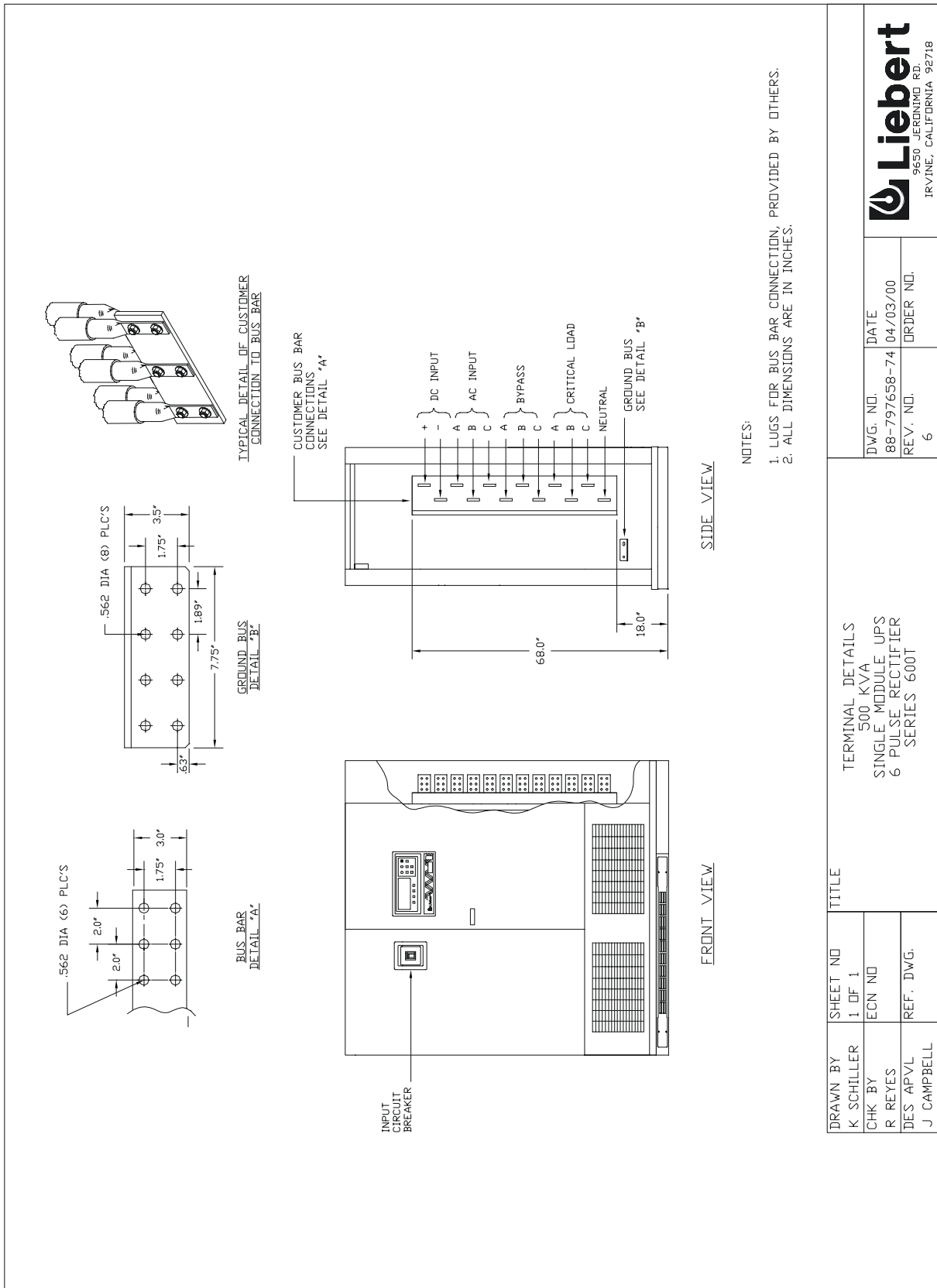

DRAWN BY K SCHILLER	SHEET NO 1 OF 1	TITLE TERMINAL DETAILS 500 KVA SINGLE MODULE UPS 6 PULSE RECTIFIER SERIES 600T	
CHK BY R REYES	ECN NO	DWG. NO. 88-797658-74	DATE 04/03/00
DES APVL J CAMPBELL	REF. DWG.	REV. NO. 6	ORDER NO.

FILE NAME: 88-797658-74-06.DWG

Liebert
9650 JEROME RD.
IRVINE, CALIFORNIA 92718

Figure 21 Bussing Details, 500 kVA SMS, 12-Pulse Rectifier

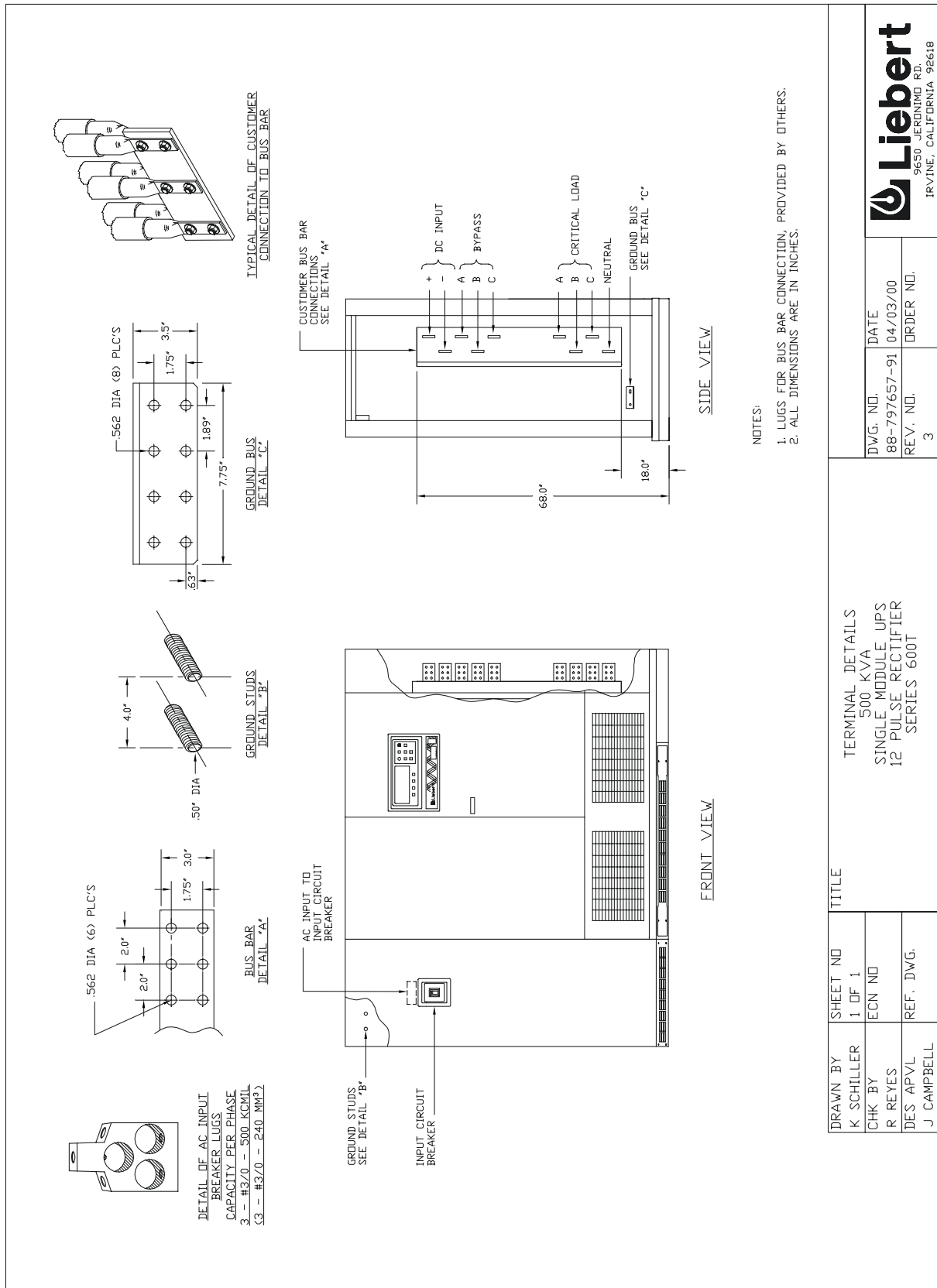

DRAWN BY K SCHILLER		SHEET NO 1 OF 1		TITLE TERMINAL DETAILS	
CHK BY R REYES		ECN NO		500 KVA SINGLE MODULE UPS 12 PULSE RECTIFIER SERIES 600T	
DES APVL J CAMPBELL		REF. DWG.		DWG. NO. 88-797657-91	DATE 04/03/00
				REV. NO. 3	ORDER NO.
 9650 JERONIMO RD. IRVINE, CALIFORNIA 92618					
FILE NAME: 88-797657-91-02.DWG					

Figure 22 Bussing Details, 625-750 SMS, 12-Pulse Rectifier

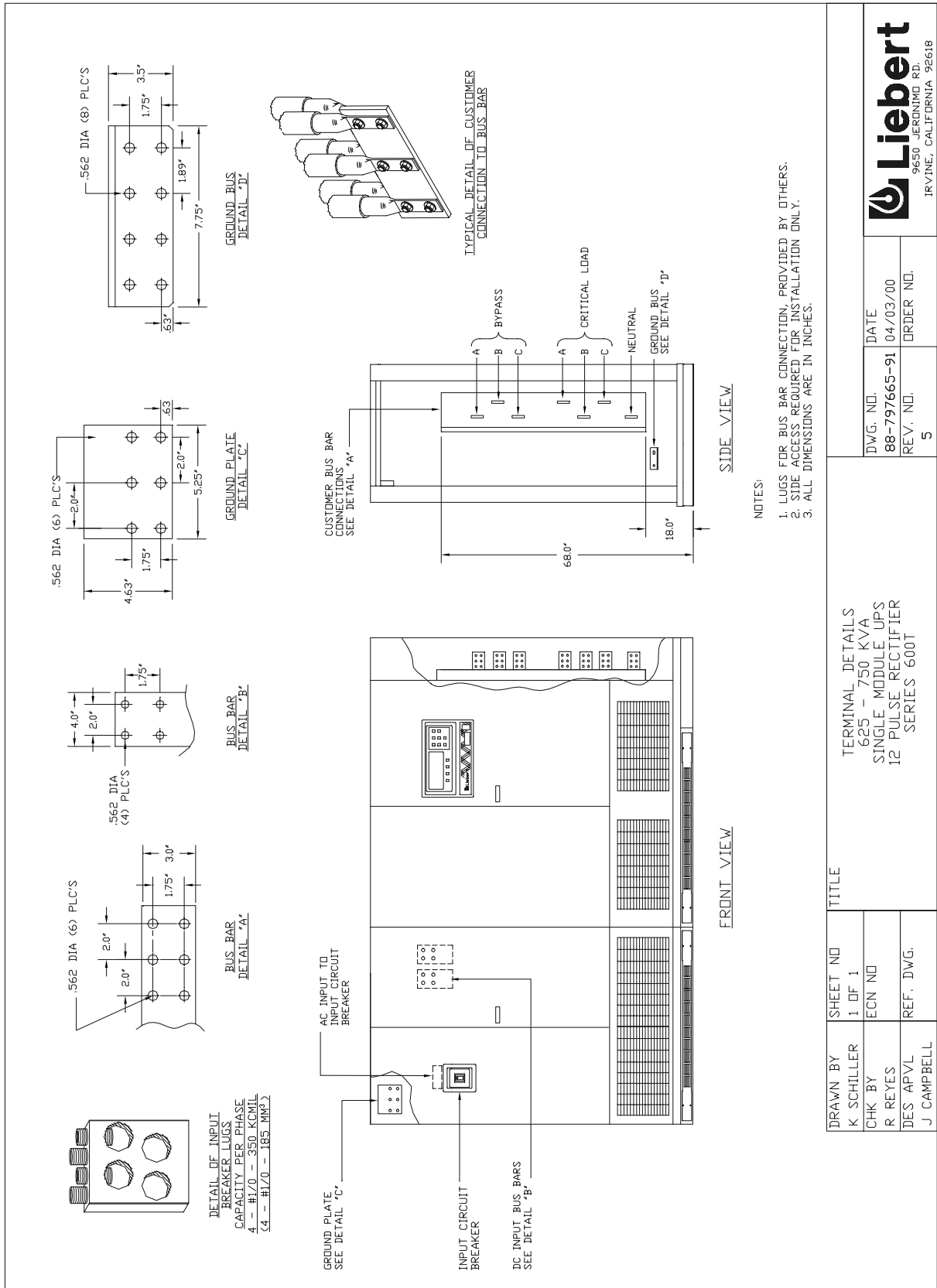
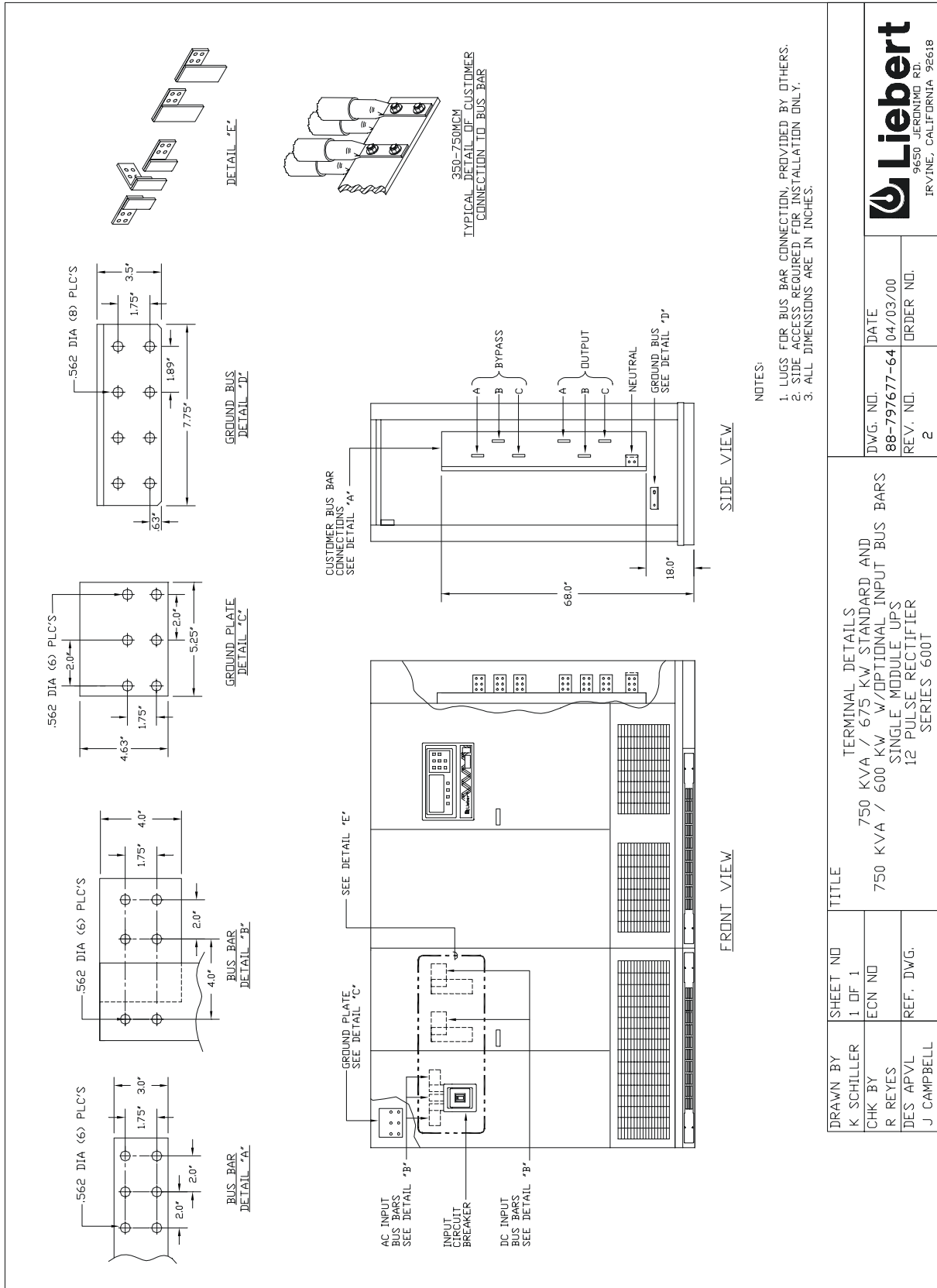

Figure 23 Bussing Details, 750 kVA/675 kW Standard and 750 kVA/600 kW Optional Input Busbars, SMS, 12-Pulse Rectifier



DRAWN BY K SCHILLER	SHEET NO 1 OF 1	TITLE TERMINAL DETAILS	DWG. NO. 88-797677-64	DATE 04/03/00
CHK BY R REYES	ECN NO	750 KVA / 675 KW STANDARD AND 750 KVA / 600 KW W/OPTIONAL INPUT BUS BARS	REV. NO. 2	ORDER NO.
DES APVL J CAMPBELL	REF. DWG.	SINGLE MODULE UPS 12 PULSE RECTIFIER SERIES 600T	FILE NAME: 88-797677-64-06.DWG	



Figure 24 Control Wiring, External Interconnect Diagram, SMS with Maintenance Bypass Panelboard or Switchboard

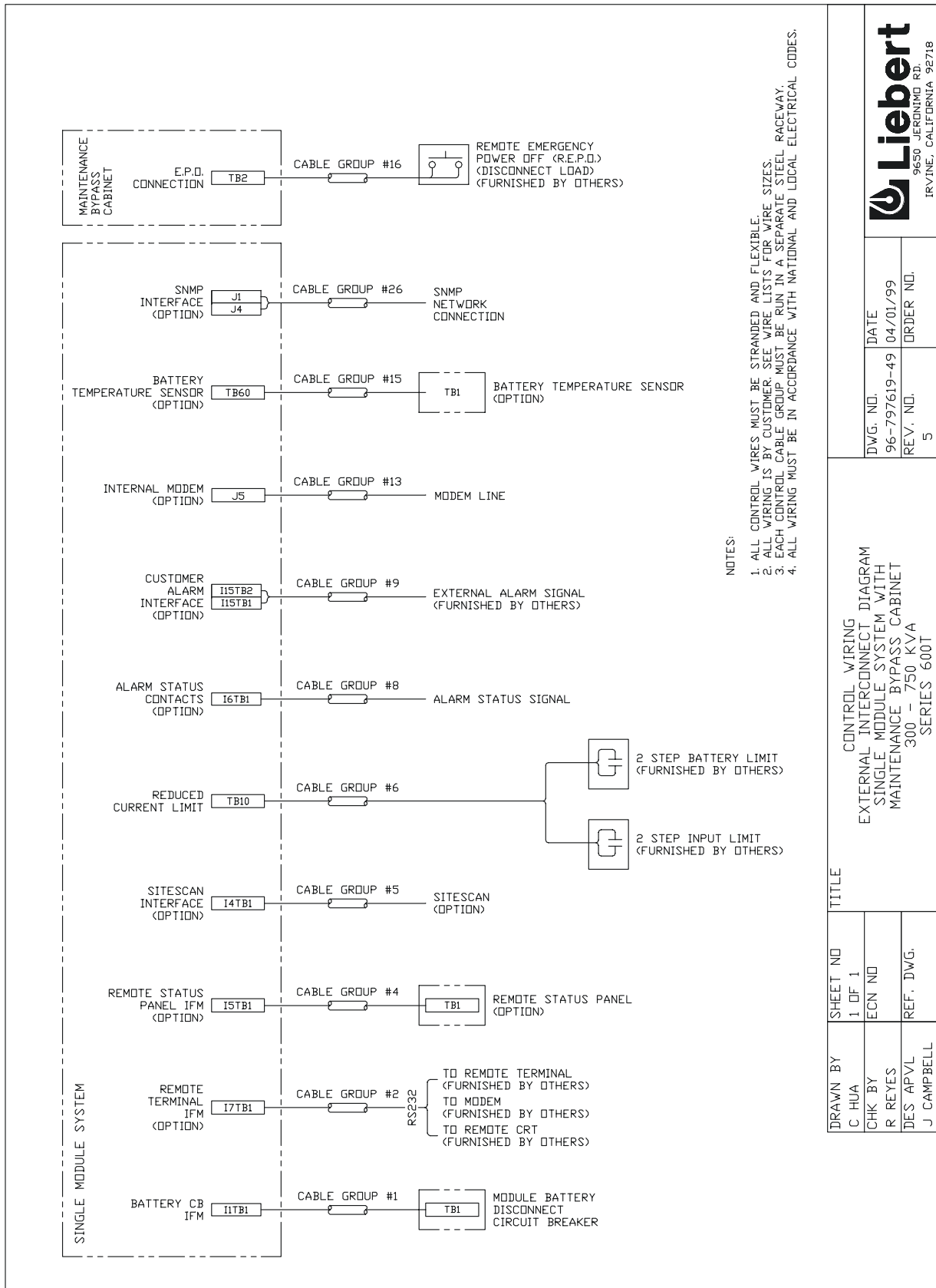

DWG. NO.	DATE
96-797619-49	04/01/99
REV. NO.	ORDER NO.
5	

FILE NAME: 96-797619-49-05.DWG

TITLE

CONTROL WIRING
EXTERNAL INTERCONNECT DIAGRAM
SINGLE MODULE SYSTEM WITH
MAINTENANCE BYPASS CABINET
300 - 750 KVA
SERIES 600T

SHEET NO	1 OF 1
CHK BY	R REYES
DES APVL	J CAMPBELL
REF. DWG.	

Figure 25 Control Connection Location Diagram, 500 kVA SMS

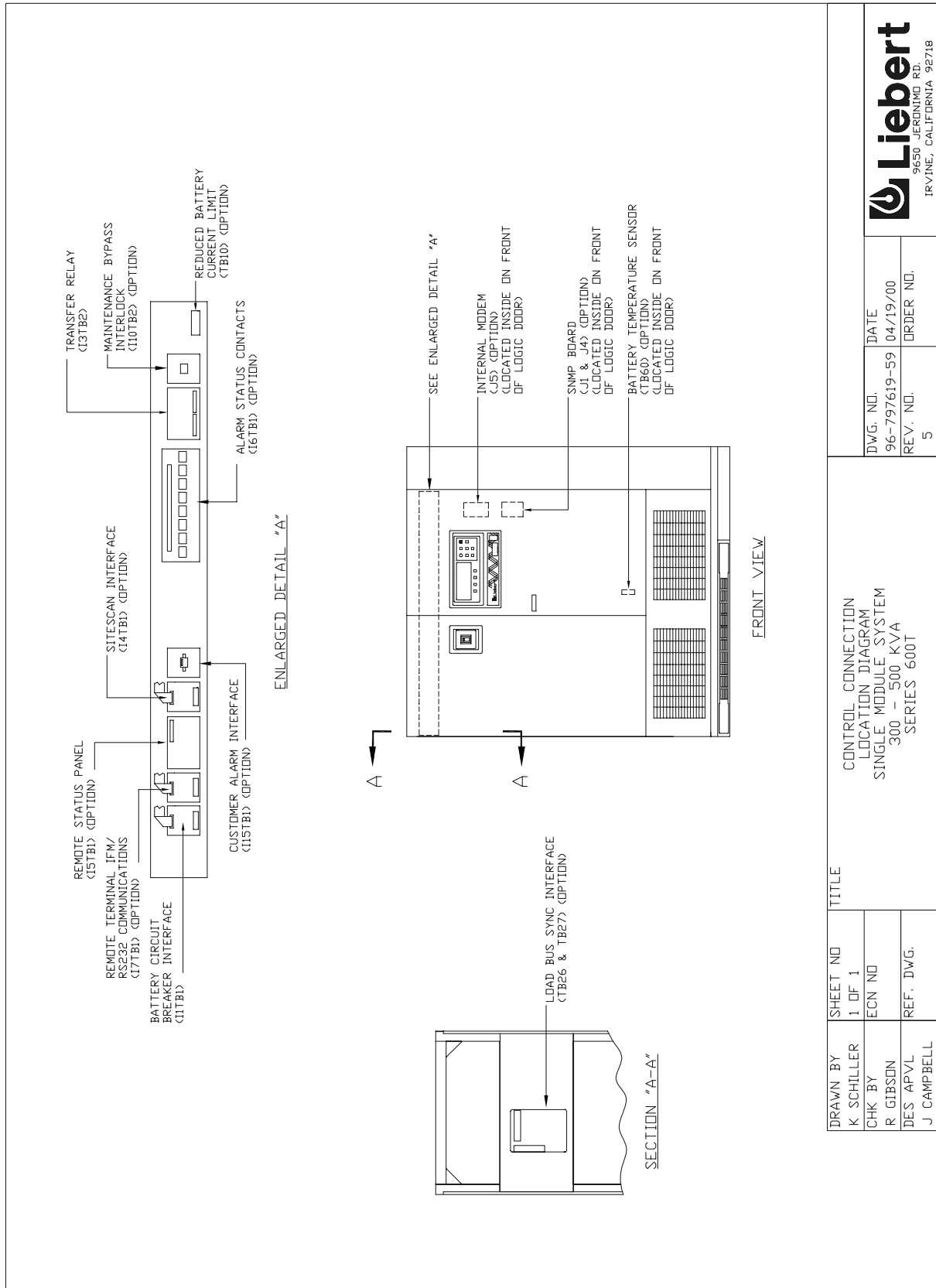

DWG. NO.	DATE
96-797619-59	04/19/00
REV. NO.	ORDER NO.
5	

FILE NAME: 96-797619-59-03.DWG

Figure 26 Control Connection Location Diagram, 625-750 kVA SMS

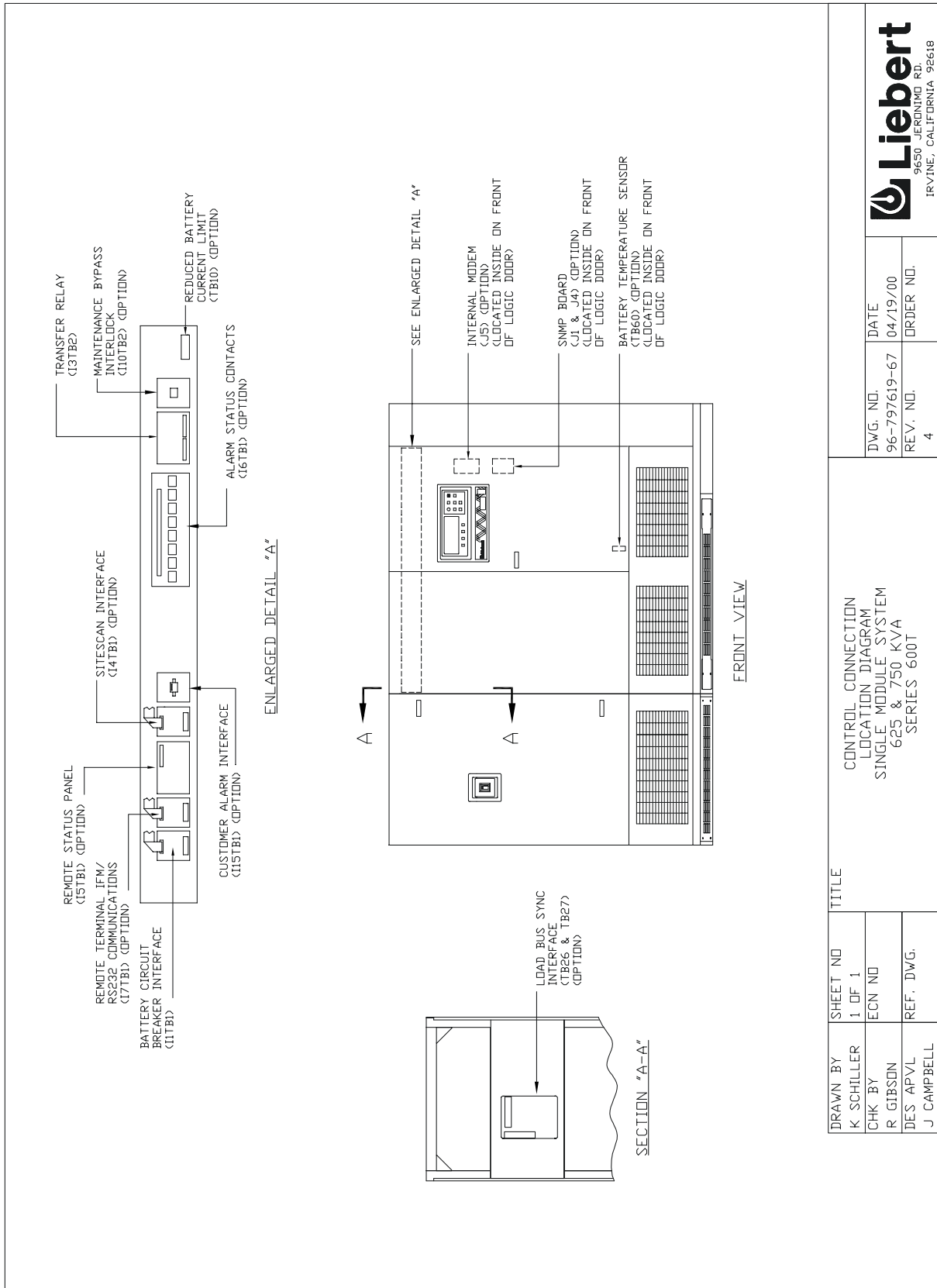

DRAWN BY K SCHILLER		SHEET NO 1 OF 1		TITLE CONTROL CONNECTION LOCATION DIAGRAM SINGLE MODULE SYSTEM 625 & 750 KVA SERIES 600T	
CHK BY R GIBSON		ECN NO		DWG. NO. 96-797619-67	
DES APVL J CAMPBELL		REF. DWG.		DATE 04/19/00	
				ORDER NO.	
				4	



FILE NAME: 96-797619-67-04.DWG

Figure 27 Control Wire List, External Interconnections, 500-750 kVA SMS

WIRE NO.	TERMINAL DESIGNATION		SIGNAL NAME	MAXIMUM VOLTAGE	MAXIMUM CURRENT	COLOR	WIRE SIZE & TYPE	MAX. LENGTH	REMARKS
	FROM	TO							
CABLE GROUP #1 (BATTERY CB IFM) FROM I1 IN UPS MODULE TO TBI ON MODULE BATTERY DISCONNECT (MBD) CIRCUIT BREAKER									
901	I1TBI-1	TBI-1	TRIP SIGNAL (+)	+24VDC	100mA				
902	I1TBI-2	TBI-2	TRIP SIGNAL (-)	-24VDC	100mA		1/C #14	500 FT. (150 METERS)	
903	I1TBI-7	TBI-7	AUX *A* COMM	24VDC	100mA				
904	I1TBI-8	TBI-8	AUX *A* N.D.	24VDC	100mA				
CABLE GROUP #6 (REDUCED CURRENT LIMIT) FROM I2 IN UPS MODULE TO CUSTOMER CONNECTION (F.B.O.)									
761	TBI0-4	N.D.	2 STEP BATTERY LIMIT	24VDC	100mA				
762	TBI0-5	COMM.	2 STEP BATTERY LIMIT	24VDC	100mA				
763	TBI0-7	N.D.	2 STEP INPUT LIMIT	24VDC	100mA		1/C #14	500 FT. (150 METERS)	
764	TBI0-8	COMM.	2 STEP INPUT LIMIT	24VDC	100mA				

- NOTES:
- EACH CABLE GROUP MUST BE RUN IN A SEPARATE STEEL RACEWAY TO PREVENT CONTROL SIGNAL INTERFERENCE.
 - REFER TO UPS MODULE CONTROL CONNECTION LOCATION DIAGRAM FOR LOCATION OF WIRING CONNECTIONS.
 - FOR OPTION WIRING CONNECTIONS, REFER TO INDIVIDUAL CONTROL WIRE LISTS.
 - F.B.O. - FURNISHED BY OTHERS.
 - ALL EXTERNAL WIRE FURNISHED BY OTHERS.
 - N.D. = NORMALLY OPEN, COMM. = COMMON.
 - ALL WIRING MUST BE IN ACCORDANCE WITH NATIONAL AND LOCAL ELECTRICAL CODES.

DRAWN BY C HUA	SHEET NO 1 OF 1	TITLE CONTROL WIRE LIST EXTERNAL INTERCONNECTIONS	
CHK BY R REYES	ECN NO	DWG. NO. 96-797619-50	DATE 04/01/99
DES APVL J CAMPBELL	REF. DWG.	REV. NO. 4	ORDER NO.
SINGLE MODULE SYSTEM w/ MAINT. BYPASS CABINET 300 - 750 KVA SERIES 600T		 9650 JERONIMO RD. IRVINE, CALIFORNIA 92618	

Figure 28 Control Wiring, Alarm Status Contacts Option

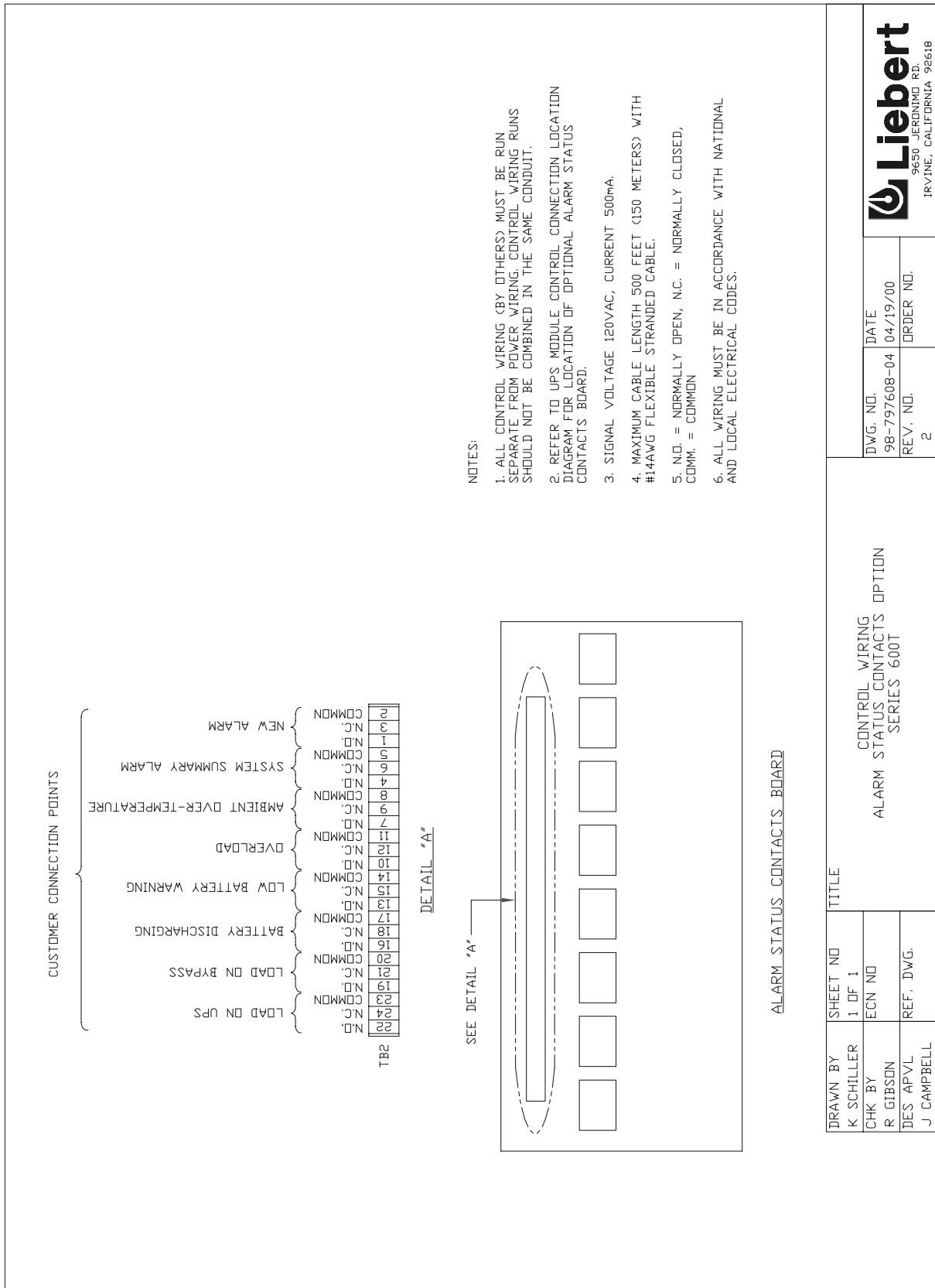
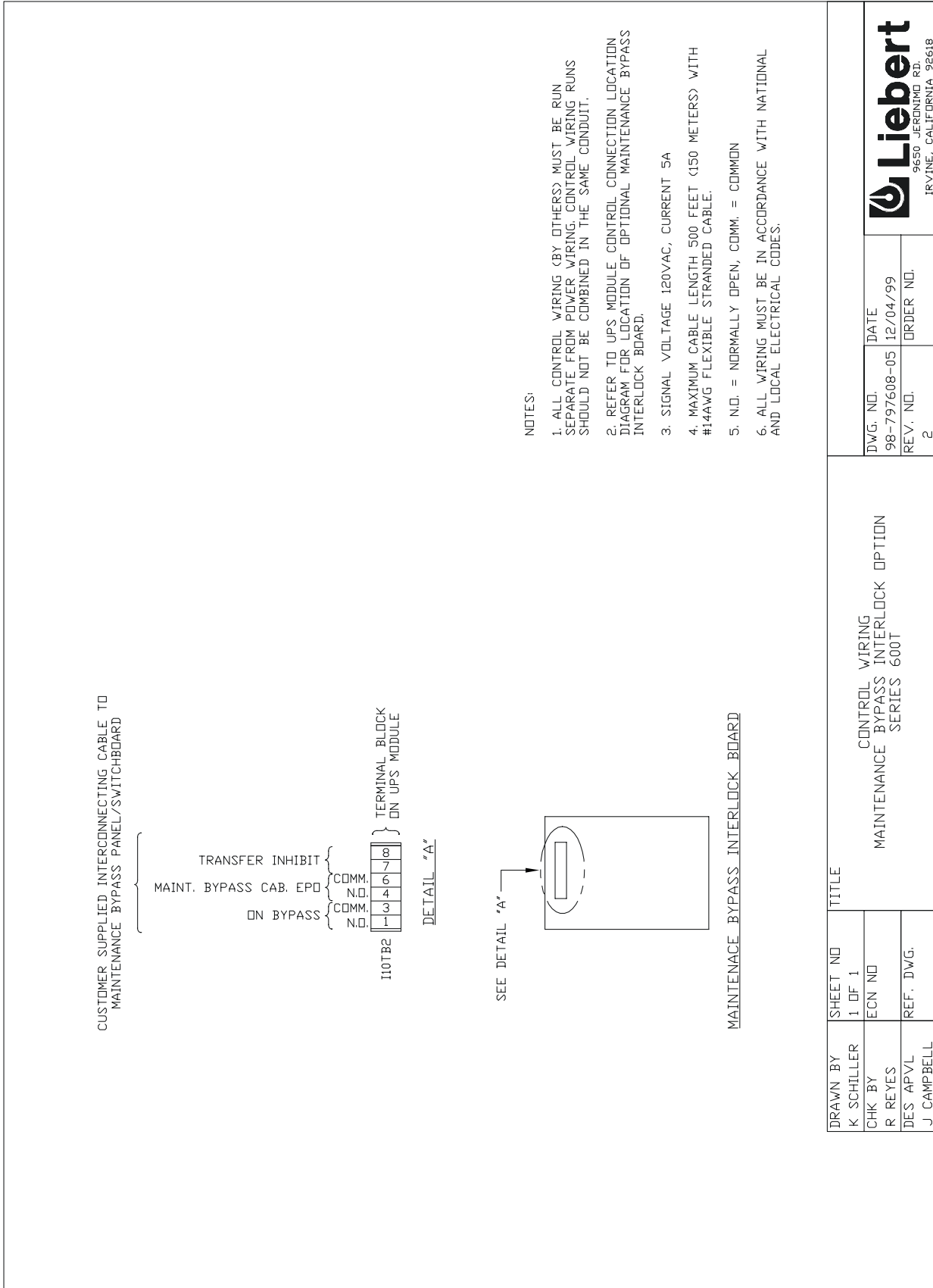

Figure 29 Control Wiring, Maintenance Bypass Interlock Option



DRAWN BY K SCHILLER	SHEET NO 1 OF 1	TITLE CONTROL WIRING MAINTENANCE BYPASS INTERLOCK OPTION SERIES 600T	
CHK BY R REYES	ECN NO	DWG. NO. 98-797608-05	DATE 12/04/99
DES APVL J CAMPBELL	REF. DWG.	REV. NO. 2	ORDER NO.
		 IRVINE, CALIFORNIA 92618	

Figure 30 Control Wiring, Remote Status Panel Interface Option

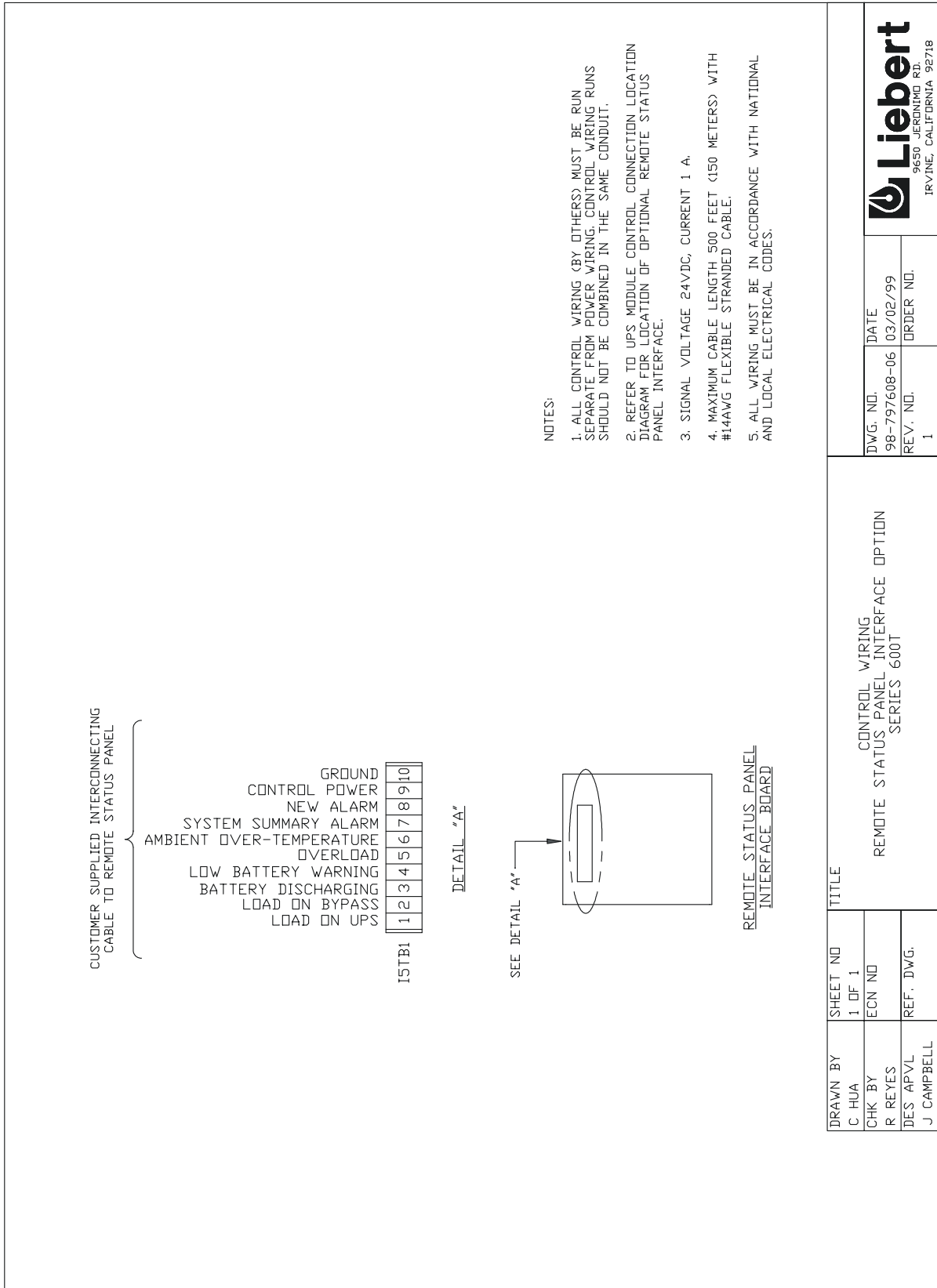

Figure 31 Control Wiring, Remote Terminal IFM (RS-232 Communications) Option

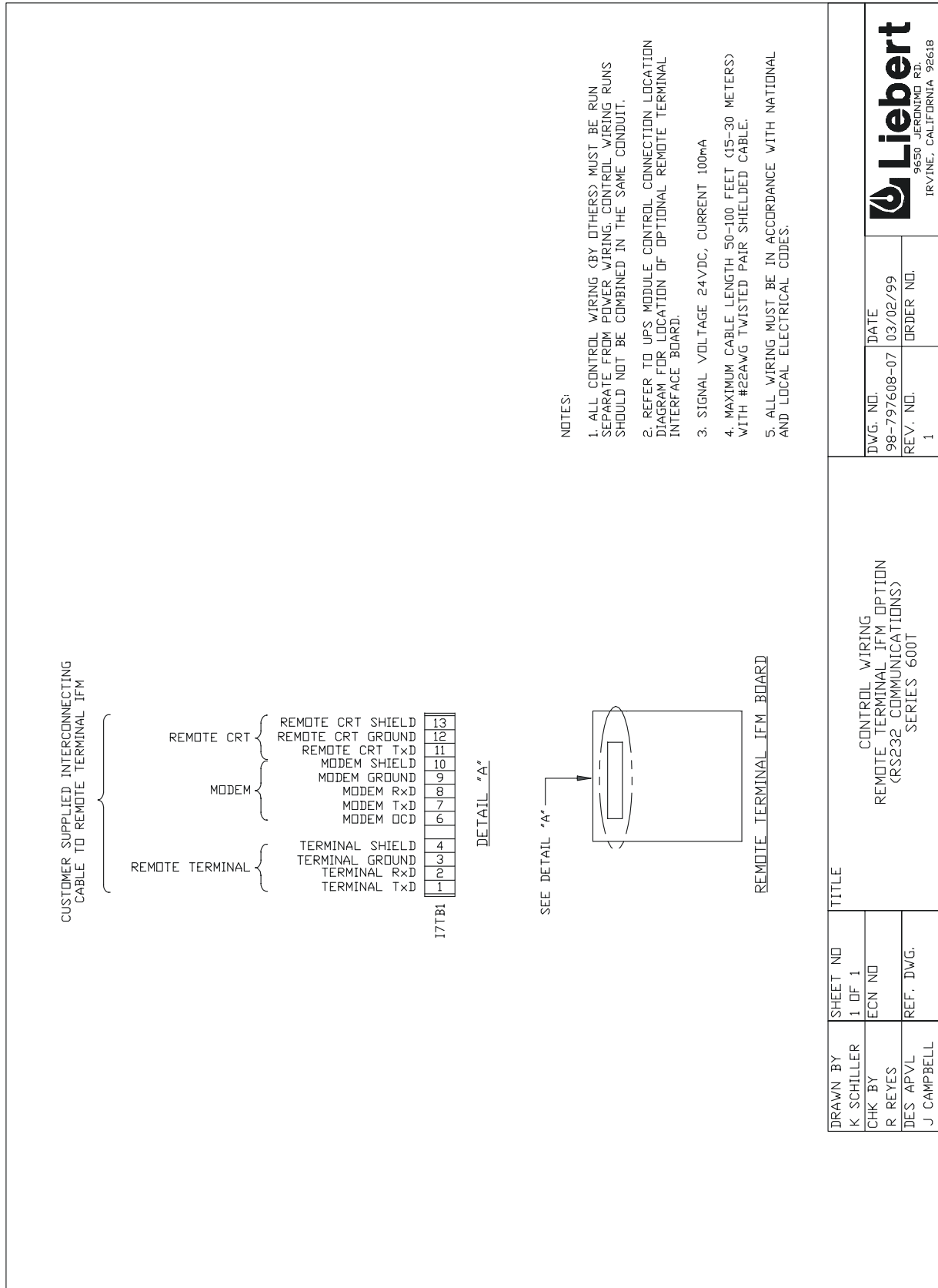
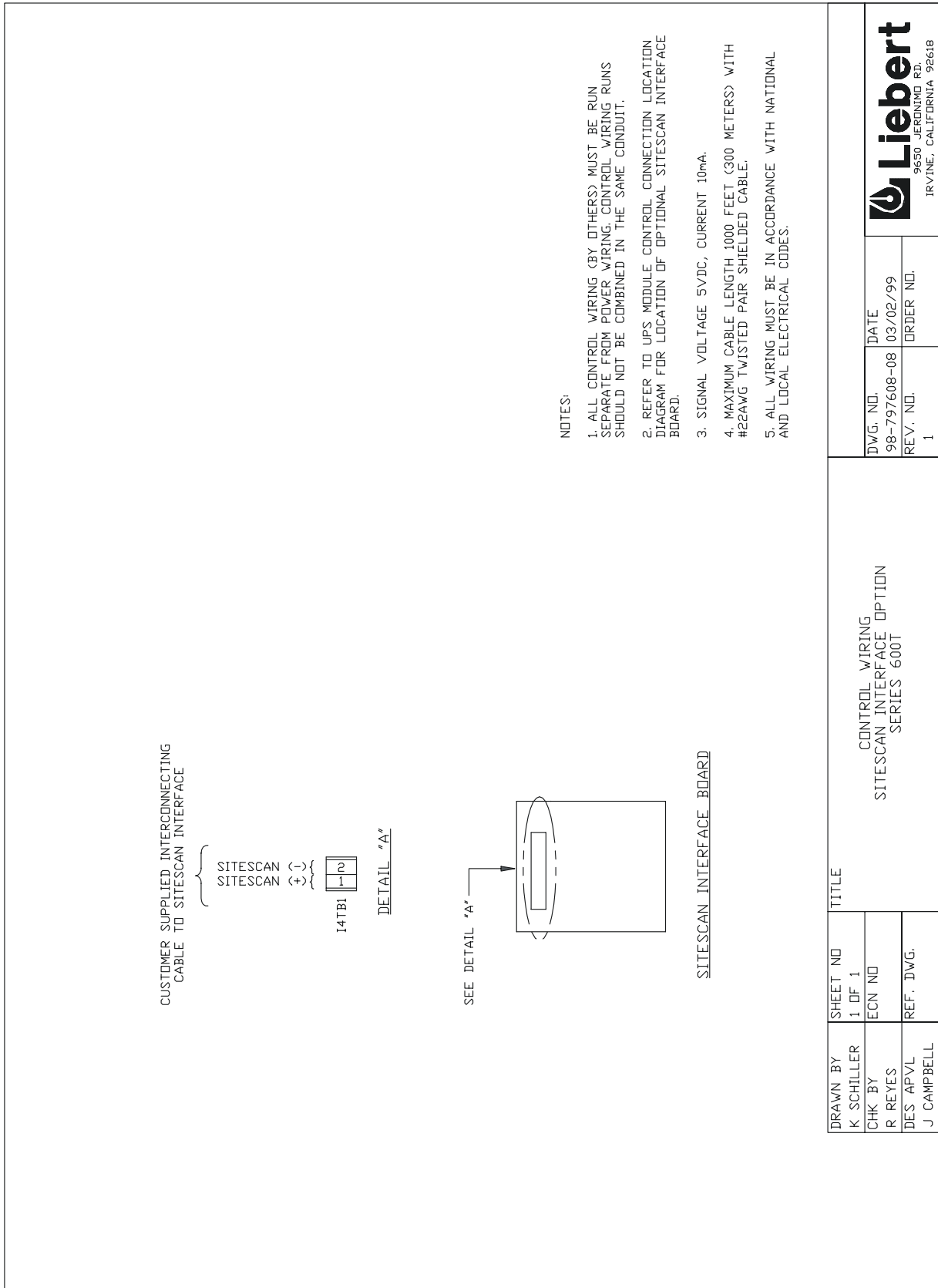

Figure 32 Control Wiring, SiteScan Interface



NOTES:

1. ALL CONTROL WIRING (BY OTHERS) MUST BE RUN SEPARATE FROM POWER WIRING. CONTROL WIRING RUNS SHOULD NOT BE COMBINED IN THE SAME CONDUIT.
2. REFER TO UPS MODULE CONTROL CONNECTION LOCATION DIAGRAM FOR LOCATION OF OPTIONAL SITESCAN INTERFACE BOARD.
3. SIGNAL VOLTAGE 5VDC, CURRENT 10mA.
4. MAXIMUM CABLE LENGTH 1000 FEET (300 METERS) WITH #22AWG TWISTED PAIR SHIELDED CABLE.
5. ALL WIRING MUST BE IN ACCORDANCE WITH NATIONAL AND LOCAL ELECTRICAL CODES.

DRAWN BY K SCHILLER		SHEET NO 1 OF 1		TITLE CONTROL WIRING SITESCAN INTERFACE OPTION SERIES 600T	
CHK BY R REYES		ECN NO		DWG. NO. 98-797508-08	
DES APVL J CAMPBELL		REF. DWG.		DATE 03/02/99	
				REV. NO. 1	
				ORDER NO.	
				 9650 JERDINMO RD. IRVINE, CALIFORNIA 92618	

FILE NAME: 98-797508-08-01.DWG

Figure 33 Control Wiring, Customer Alarm Interface Option

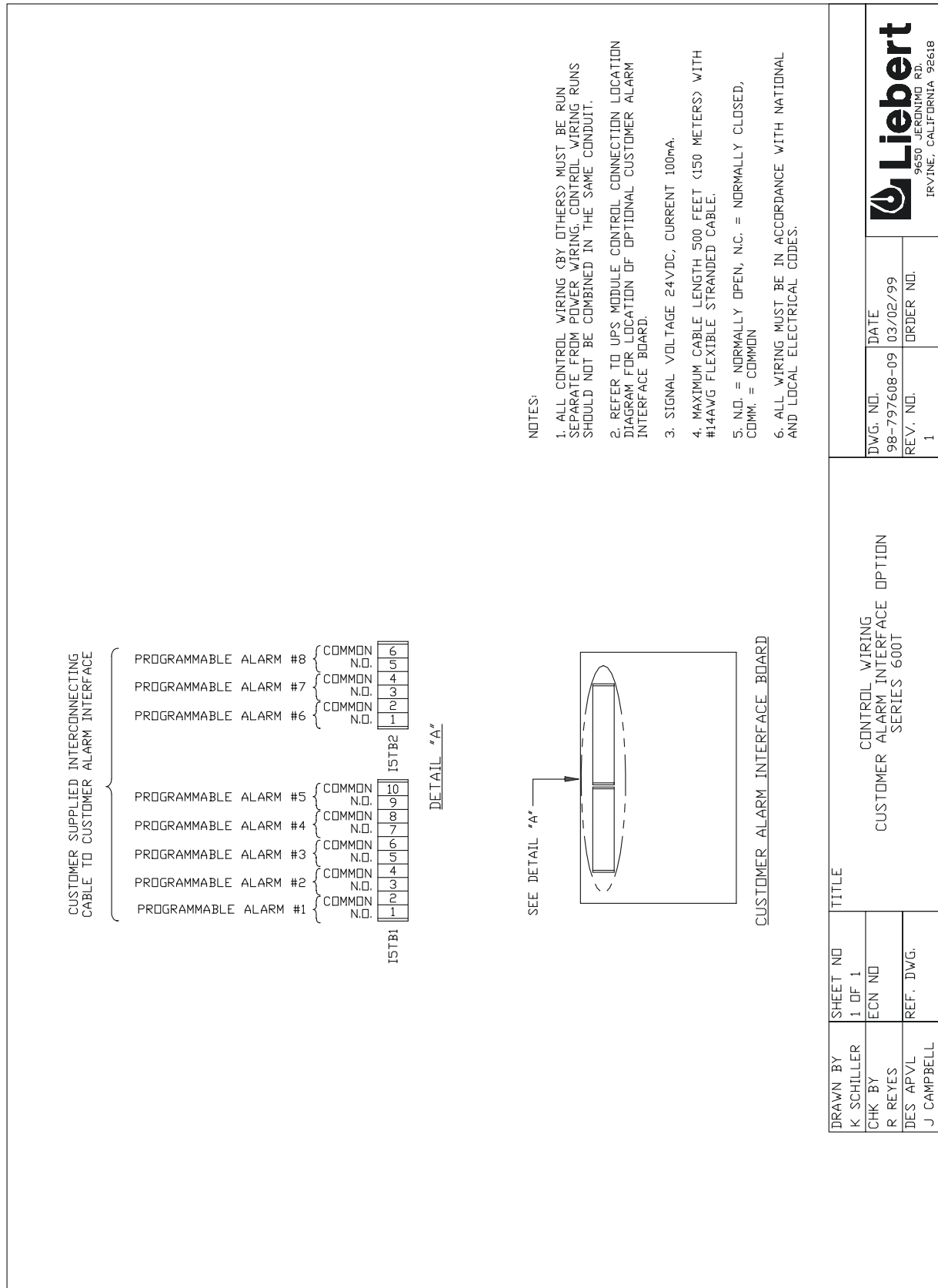
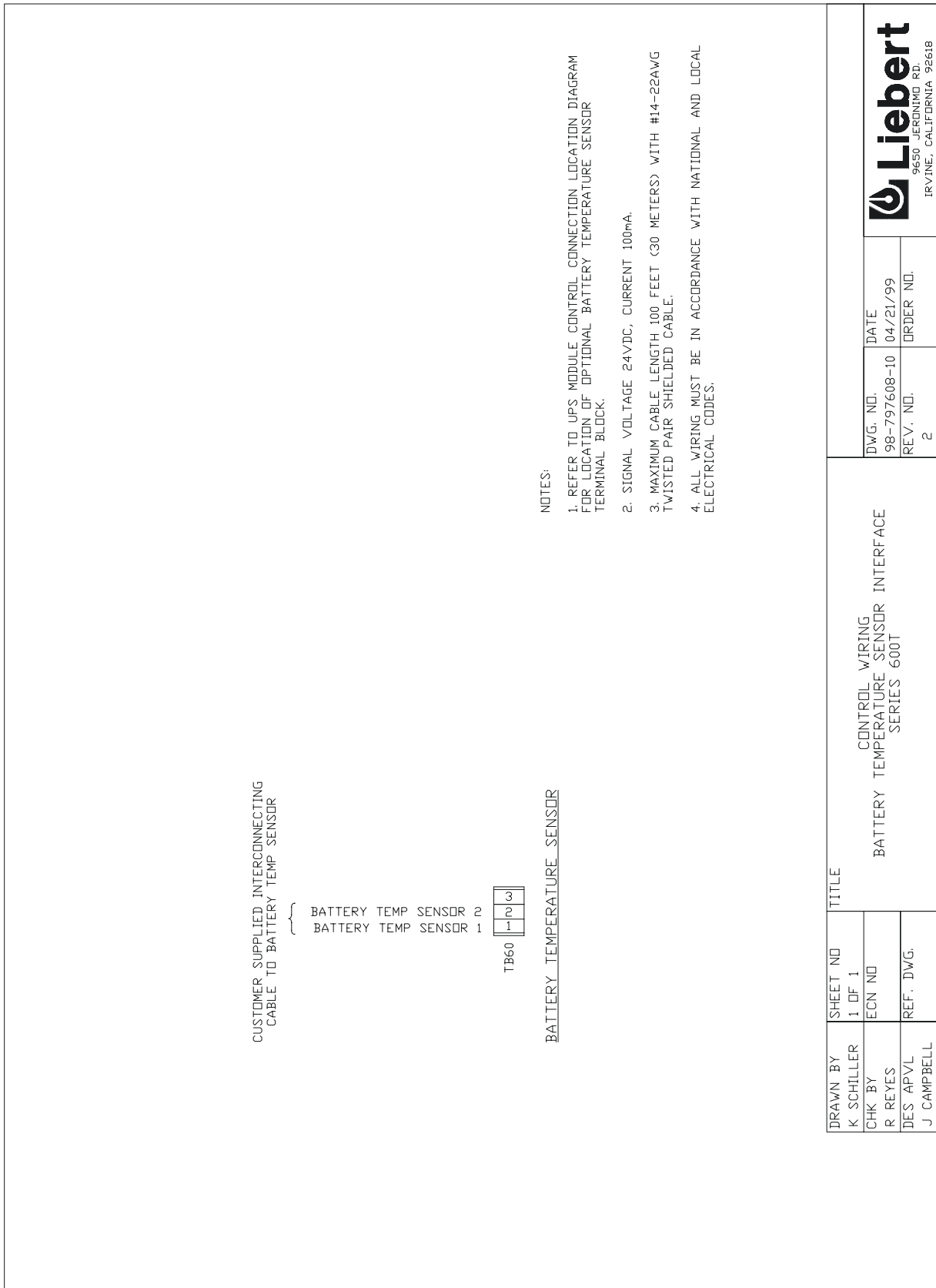

Figure 34 Control Wiring, Battery Temperature Sensor Interface



NOTES:

1. REFER TO UPS MODULE CONTROL CONNECTION LOCATION DIAGRAM FOR LOCATION OF OPTIONAL BATTERY TEMPERATURE SENSOR TERMINAL BLOCK.
2. SIGNAL VOLTAGE 24VDC, CURRENT 100mA.
3. MAXIMUM CABLE LENGTH 100 FEET (30 METERS) WITH #14-22AWG TWISTED PAIR SHIELDED CABLE.
4. ALL WIRING MUST BE IN ACCORDANCE WITH NATIONAL AND LOCAL ELECTRICAL CODES.

DRAWN BY K SCHILLER	SHEET NO 1 OF 1	TITLE CONTROL WIRING BATTERY TEMPERATURE SENSOR INTERFACE SERIES 600T	
CHK BY R REYES	ECN NO	DWG. NO. 98-797608-10	DATE 04/21/99
DES APVL J CAMPBELL	REF. DWG.	REV. NO. 2	ORDER NO.



FILE NAME: 98-797608-10-02.DWG

Figure 35 Control Wiring, SNMP Interface Option

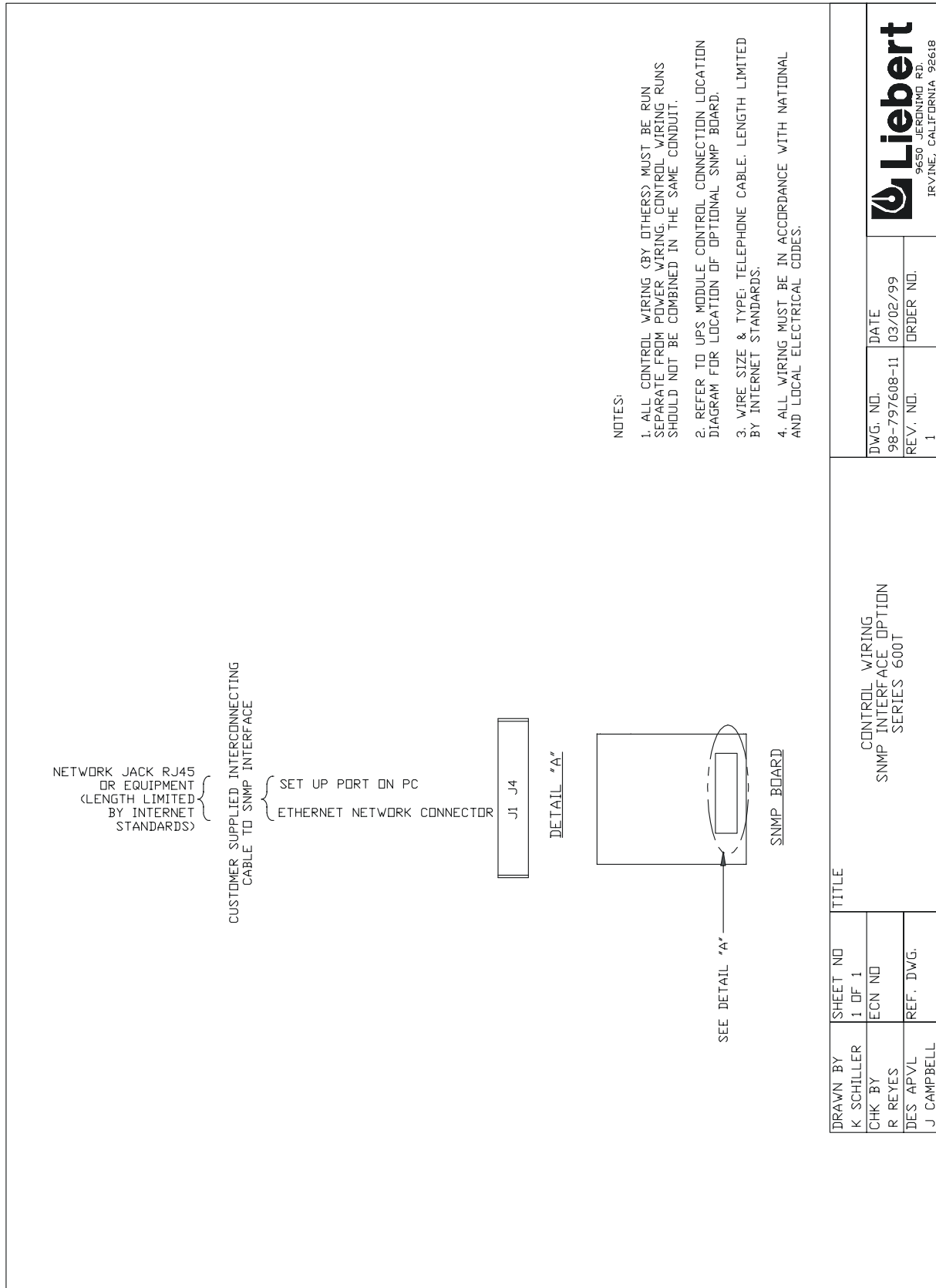
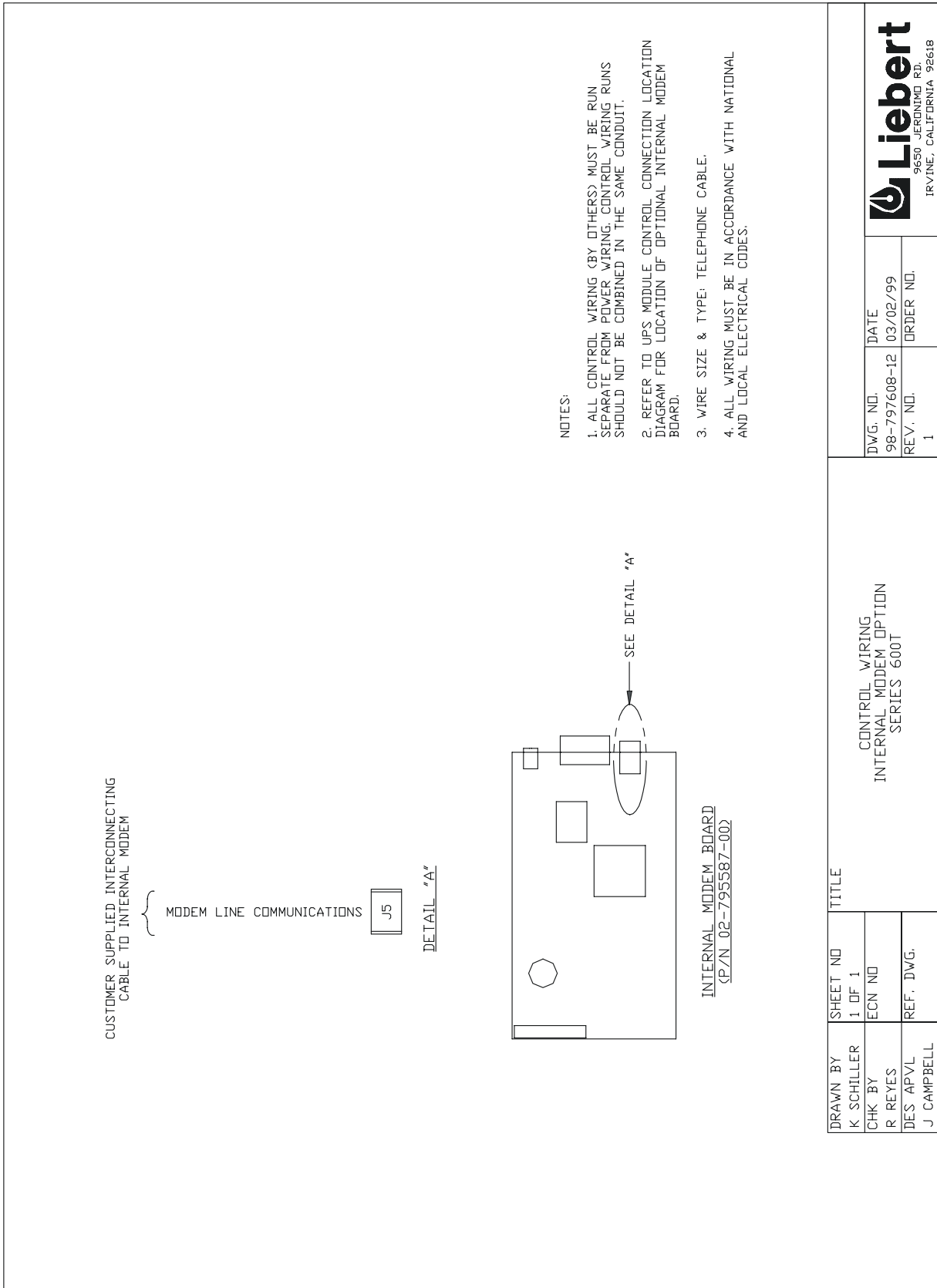

Figure 36 Control Wiring, Internal Modem Option



NOTES:

1. ALL CONTROL WIRING (BY OTHERS) MUST BE RUN SEPARATE FROM POWER WIRING. CONTROL WIRING RUNS SHOULD NOT BE COMBINED IN THE SAME CONDUIT.
2. REFER TO UPS MODULE CONTROL CONNECTION LOCATION DIAGRAM FOR LOCATION OF OPTIONAL INTERNAL MODEM BOARD.
3. WIRE SIZE & TYPE: TELEPHONE CABLE.
4. ALL WIRING MUST BE IN ACCORDANCE WITH NATIONAL AND LOCAL ELECTRICAL CODES.

INTERNAL MODEM BOARD
(P/N 02-795587-00)

DRAWN BY	SHEET NO	TITLE
K SCHILLER	1 OF 1	CONTROL WIRING INTERNAL MODEM OPTION SERIES 600T
CHK BY	ECN NO	
R REYES	REF. DWG.	
DES APVL		
J CAMPBELL		

DWG. NO.	DATE
98-797608-12	03/02/99
REV. NO.	ORDER NO.
1	



FILE NAME: 98-797608-12-01.DWG

Figure 37 Control Wiring, Maintenance Bypass Cabinet Option

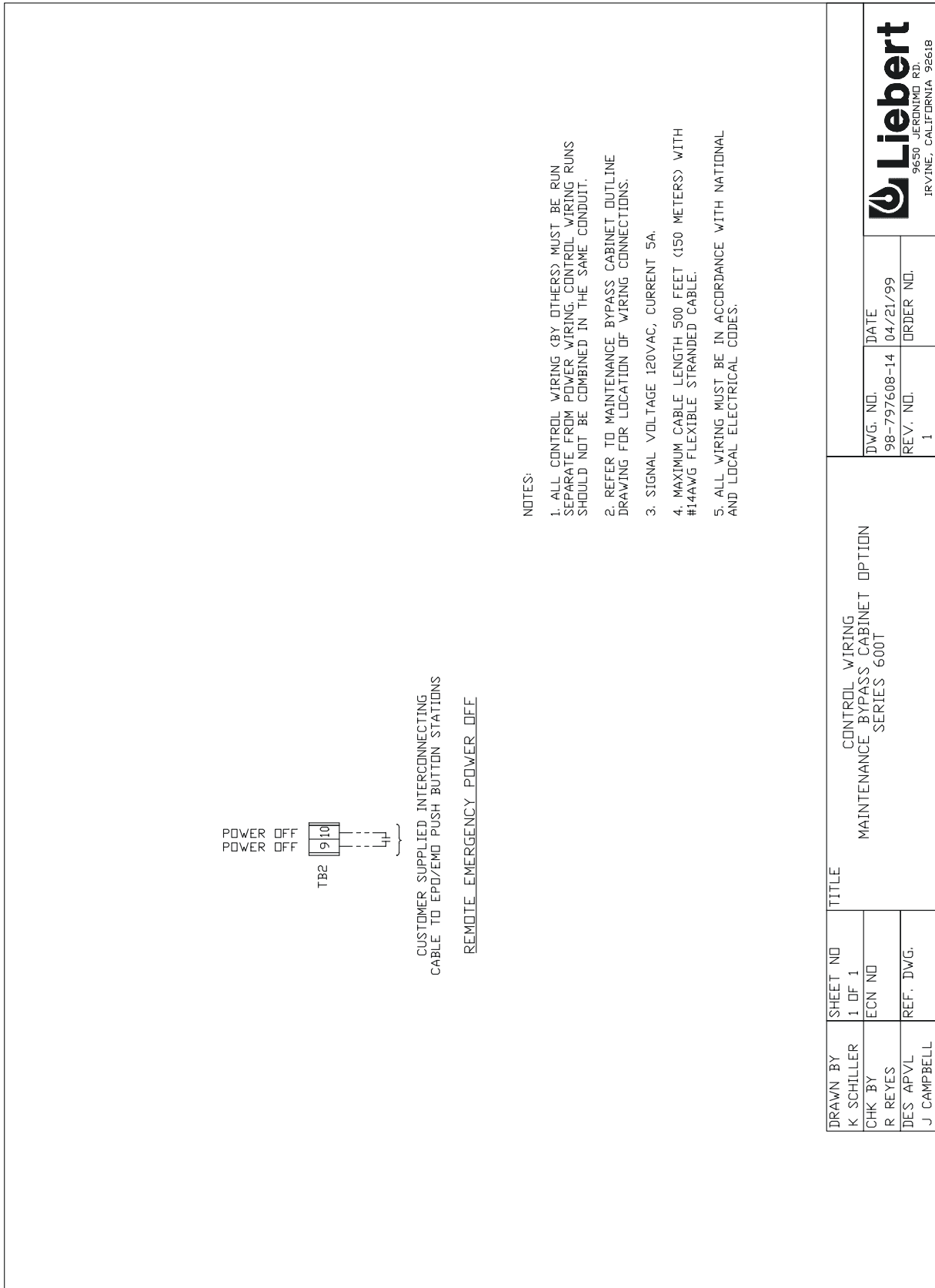
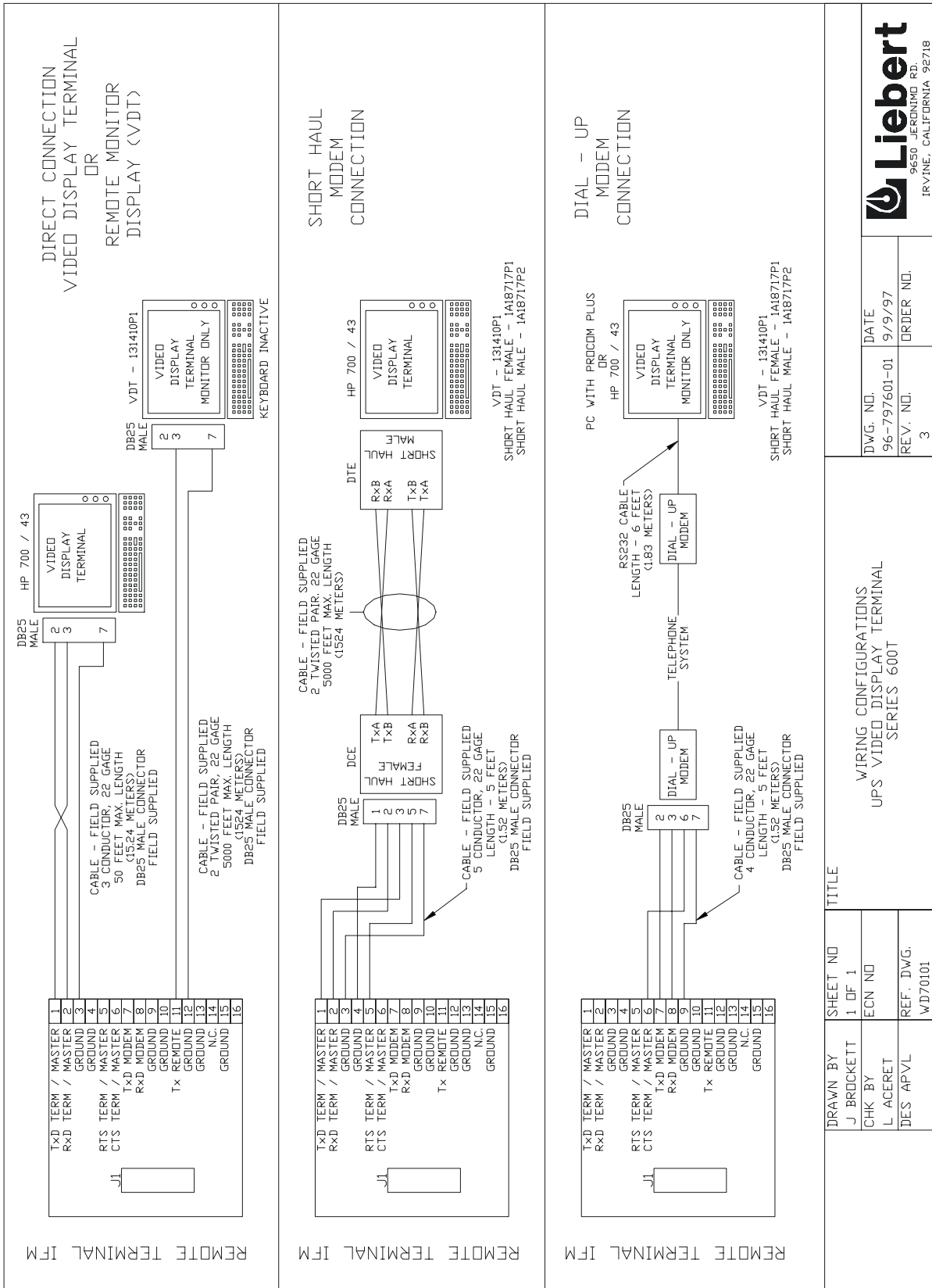

Figure 38 Wiring Configurations, UPS Video Display Terminal



DWG. NO.	DATE
96-797601-01	9/9/97
REV. NO.	ORDER NO.
3	

FILE NAME: WD7003.DWG

WIRING CONFIGURATIONS UPS VIDEO DISPLAY TERMINAL SERIES 600T	
TITLE	SHEET NO
	1 OF 1
DRAWN BY	ECN NO
J. BROCKETT	
CHK BY	REF. DWG.
L. ACERET	WD70101
DES' APVL	

Figure 39 Outline Drawing, Module Battery Disconnect, 500 kVA SMS with 6-Pulse Rectifier

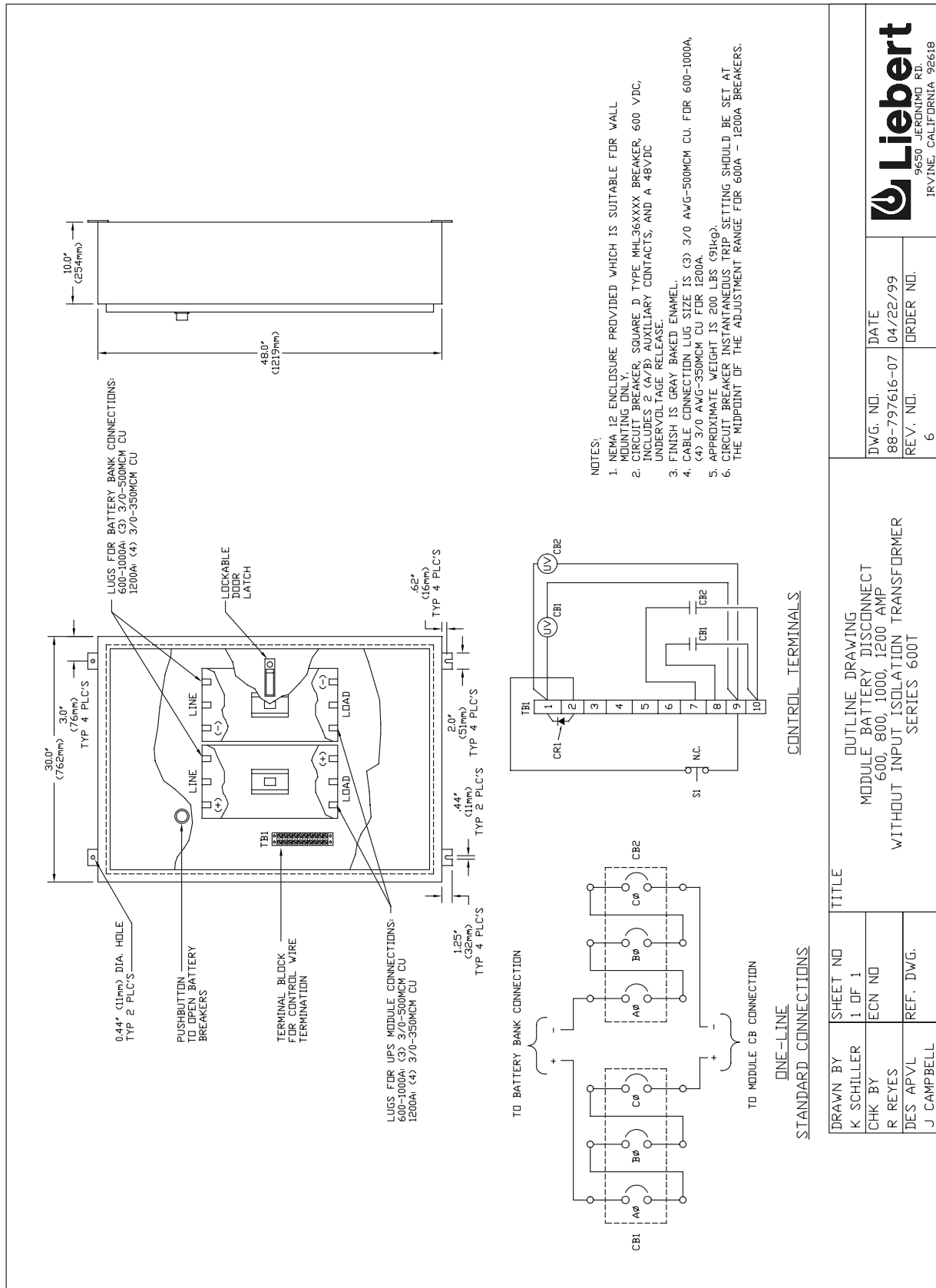

DWG. NO. 88-797616-07
 REV. NO. 6
 DATE 04/22/99
 ORDER NO.

OUTLINE DRAWING
 MODULE BATTERY DISCONNECT
 600, 800, 1000, 1200 AMP
 WITHOUT INPUT ISOLATION TRANSFORMER
 SERIES 600T

DRAWN BY	K. SCHILLER	SHEET NO	1 OF 1	TITLE	OUTLINE DRAWING
CHK BY	R. REYES	ECN NO			MODULE BATTERY DISCONNECT
DES. APVL	J. CAMPBELL	REF. DWG.			600, 800, 1000, 1200 AMP
					WITHOUT INPUT ISOLATION TRANSFORMER
					SERIES 600T

FILE NAME: 88-797616-07-06.DWG

Figure 40 Outline Drawing, Module Battery Disconnect, 500-750 kVA SMS with 12-Pulse Rectifier

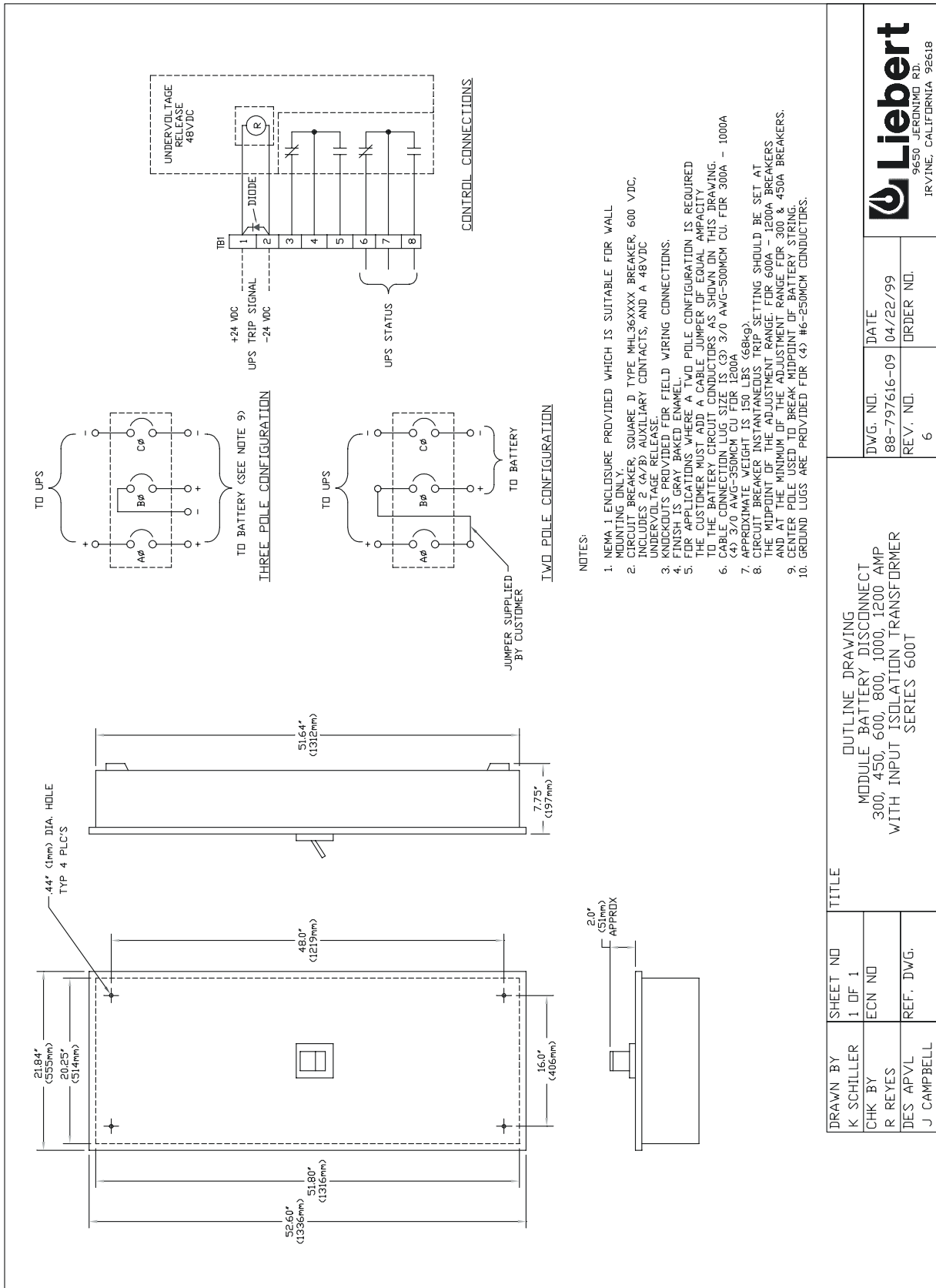
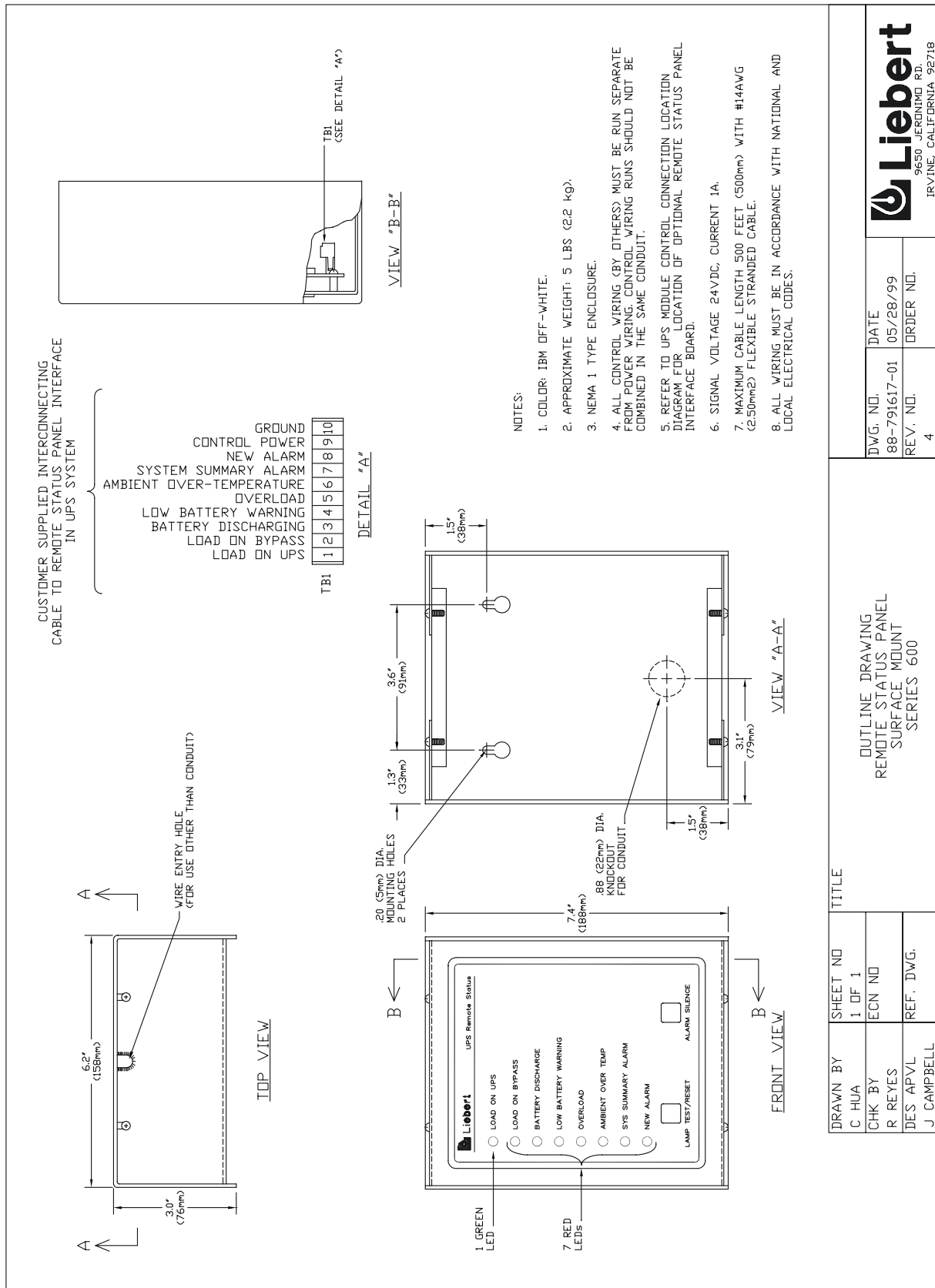

Figure 41 Remote Status Panel, Surface Mount



DRAWN BY		SHEET NO		TITLE	
C HUA		1 OF 1		OUTLINE DRAWING REMOTE STATUS PANEL SURFACE MOUNT SERIES 600	
CHK BY		ECN NO			
R REYES					
DES APVL		REF. DWG.			
J CAMPBELL					
DWG. NO.		DATE		Liebert	
88-791617-01		05/28/99		9650 JERDINMO RD.	
REV. NO.		ORDER NO.		IRVINE, CALIFORNIA 92718	
4					
FILE NAME: 88-791617-01-04.DWG					

Figure 42 Circuit Breaker Schedule, 300-750 kVA

SERIES 600T SINGLE MODULE CIRCUIT BREAKER SCHEDULE												
USAGE KVA/KW	INPUT CIRCUIT BREAKER (CB1)						OUTPUT (CB2) / BYPASS (CB3) CIRCUIT BREAKER					
	VOLTAGE IN	VENDOR	TYPE	INTERRUPTING RATING AIC	VOLTAGE OUT	VENDOR	TYPE	INTERRUPTING RATING AIC	VOLTAGE OUT	VENDOR	TYPE	INTERRUPTING RATING AIC
300/240	208V 480V 600V	SQUARE D	MHL MHL MHL	65K 65K 25K	208V 480V 600V	MERLIN GERIN	CKHH NJHF NJHF	100K 65K 25K				
400/320	208V (1) 480V 600V	SQUARE D	MHL MHL MHL	65K 65K 25K	208V 480V 600V	MERLIN GERIN	CKHH NJHF NJHF	100K 65K 25K				
400/360	480V	SQUARE D	MHL	65K	480V	MERLIN GERIN	NJHF	65K				
450/360	480V	SQUARE D	MHL	65K	480V	MERLIN GERIN	CKHH	65K				
500/400	480V 600V	SQUARE D	MHL MHL	65K 25K	480V 600V	MERLIN GERIN	CKHH CKHH	65K 42K				
500/450	480V 600V	SQUARE D	MHL MHL	65K 25K	480V 600V	MERLIN GERIN	CKHH CKHH	65K 42K				
625/500	480V 600V	SQUARE D	MHL MHL	65K 25K	480V 600V	MERLIN GERIN	CKHH CKHH	65K 42K				
750/600	480V 600V	SQUARE D	MHL MHL	65K 25K	480V 600V	MERLIN GERIN	CKHH CKHH	65K 42K				
750/675	480V 600V	MERLIN GERIN	CKHH CKHH	65K 42K	480V 600V	MERLIN GERIN	CKHH CKHH	65K 42K				

NOTES:

- 400KVA 208V INPUT/OUTPUT USES AN INPUT TRANSFORMER CABINET FOR 208V TO 480V CONVERSION.
THE UPS MODULE IS 480V/208V.

DRAWN BY	SHEET NO	TITLE
K SCHILLER	1 OF 1	CIRCUIT BREAKER SCHEDULE SINGLE MODULE UPS 300-750 KVA SERIES 600T
CHK BY	ECN NO	
R REYES		
DES APVL	REF. DWG.	
J CAMPBELL		



9630 JEROME RD.
IRVINE, CALIFORNIA 92618

DWG. NO.	DATE
84-797605-112	04/07/00
REV. NO.	ORDER NO.
2	

FILE NAME: 84-797605-112-03.DWG

12.0 APPENDIX A - SITE PLANNING DATA

500-750 kVA Single Module Systems

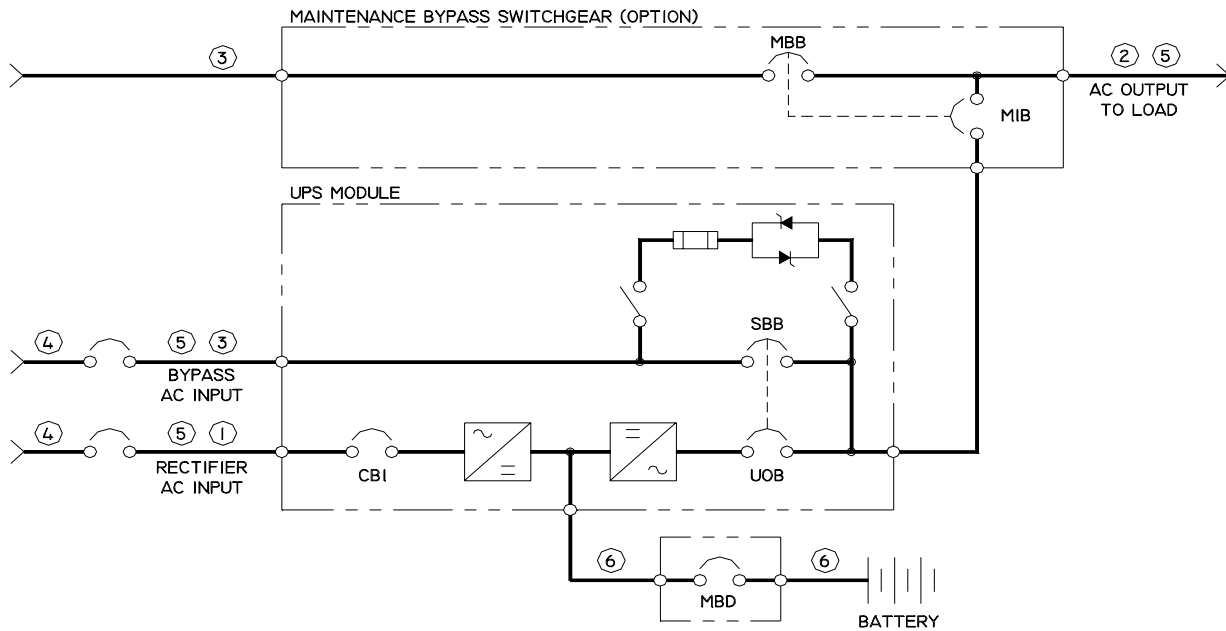

12.1 Notes

1. Nominal rectifier AC input current (considered continuous) is based on full rated output load. Maximum current includes nominal input current and maximum battery recharge current (considered noncontinuous). Continuous and noncontinuous current limit are defined in NEC 100. Maximum input current is controlled by current limit setting which is adjustable. Values shown are for maximum setting of 125%. Standard factory setting is 115%.
2. Nominal AC output current (considered continuous) is based on full rated output load. Maximum current includes nominal output current and overload for 10 minutes.
3. Bypass AC input current (considered continuous) is based on full rated output load.
4. Feeder protection (by others in external equipment) for rectifier AC input and bypass AC input is recommended to be provided by separate overcurrent protection devices.
5. UPS output load cables must be run in separate conduit from input cables.
6. Power cable from module DC bus to battery should be sized for a total maximum 2.0 volt line drop (measured at the module) at maximum discharge current.
7. Grounding conductors to be sized per NEC 250-95. Neutral conductors to be sized for full capacity—per NEC 310-16, Note 10—for systems with 4-wire loads and half capacity for systems with 3-wire loads.
8. Rectifier AC Input: 3-phase, 3-wire, plus ground
AC Output to Load: 3-phase, 3 or 4-wire, plus ground
Bypass AC Input: 3-phase, 3 or 4-wire, plus ground
Module DC Input from Battery: 2-wire, (positive and negative)
9. All wiring is to be in accordance with National and Local Electrical Codes.
10. Minimum clearance is 2 feet above UPS.
11. Top or bottom cable entry through removable access plates. Cut plate to suit conduit size.
12. Control wiring and power cables must be run in separate conduits. Control wiring must be stranded conductors.
13. For systems with six-pulse rectifiers: 7% maximum input harmonic current and 0.92 lagging input power factor at full load with optional input filter. 30% maximum input harmonic current and 0.85 lagging input power factor at full load without optional input filter.
14. For systems with 12-pulse rectifiers: 4% maximum input harmonic current and 0.92 lagging input power factor at full load with optional input filter. 9% maximum input harmonic current and 0.85 lagging input power factor at full load without optional input filter.

Table 4 Site Planning Data, 480 Volt Input

UPS Rating		AC Output Voltage	Options		Rectifier AC Input Current		Inverter or Bypass Output Current		Required Battery Disconnect	Maximum Battery Current at End of	Maximum Heat Dissipation (BTU/Hr)	Dimensions Inches	Approx. Weight	Floor Loading (Lb/Sq Ft) (concentrated loading)	
kVA	kW		Input Filter	Input Xfmr	Nom	Max	Nom	Max	Rating (Amperes)	Dis-charge (Amperes)	Full Load	(WxDxH)	(unpacked)		
500	400	480	NO	NO	602	753	601	752	1,000	1,079	87,150	72x39x79	5,775	296	
500	400	480	YES	NO	558	698	601	752	1,000	1,079	91,800	72x39x79	5,975	306	
500	400	480	NO	YES	612	765	601	752	1,000	1,079	110,700	96x39x79	8,775	338	
500	400	480	YES	YES	565	707	601	752	1,000	1,079	115,500	96x39x79	8,975	345	
500	450	480	NO	NO	677	847	601	752	1,200	1,214	98,050	72x39x79	5,795	297	
500	450	480	YES	NO	628	785	601	752	1,200	1,214	103,250	72x39x79	5,995	307	
500	450	480	NO	YES	688	861	601	752	1,200	1,214	124,550	96x39x79	9,095	350	
500	450	480	YES	YES	638	798	601	752	1,200	1,214	129,931	96x39x79	9,295	358	
625	500	480	NO	NO	749	936	752	936	1,400	1,349	99,300	108x39x79	7,500	256	
625	500	480	YES	NO	694	867	752	936	1,400	1,349	105,050	108x39x79	7,720	264	
625	500	480	NO	YES	757	946	752	936	1,400	1,349	118,650	120x39x79	10,580	326	
625	500	480	YES	YES	701	877	752	936	1,400	1,349	124,509	120x39x79	10,800	332	
750	600	480	NO	NO	898	1123	902	1128	1,600	1,619	119,200	108x39x79	8,100	277	
750	600	480	YES	NO	833	1041	902	1128	1,600	1,619	126,100	108x39x79	8,320	284	
750	600	480	NO	YES	908	1135	902	1128	1,600	1,619	142,350	120x39x79	11,580	356	
750	600	480	YES	YES	842	1052	902	1128	1,600	1,619	149,410	120x39x79	11,800	363	
750	675	480	NO	YES	1022	1277	902	1128	1,600	1,822	160,150	120x39x79	11,880	366	
750	675	480	YES	YES	947	1184	902	1128	1,600	1,822	168,100	120x39x79	12,100	372	
			13		1,4,5,7,8,9,11,12		2,3,5,7,8,9,11,12		6	6,8,9,11,12					

Table 5 Site Planning Data, 600 Volt Input

UPS Rating		AC Output Voltage	Options		Rectifier AC Input Current		Inverter or Bypass Output Current		Required Battery Disconnect	Maximum Battery Current at End of	Maximum Heat Dissipation (BTU/Hr)	Dimensions Inches	Approx. Weight	Floor Loading (Lb/Sq Ft) (concentrated loading)	
kVA	kW		Input Filter	Input Xfmr	Nom	Max	Nom	Max	Rating (Amperes)	Discharge (Amperes)	Full Load	(WxDxH)	(unpacked)		
500	400	600	NO	NO	484	605	481	601	1,000	1,079	94,900	72x39x79	6,175	317	
500	400	600	YES	NO	449	561	481	601	1,000	1,079	99,600	72x39x79	6,375	327	
500	400	600	NO	YES	490	612	481	601	1,000	1,079	110,700	96x39x79	8,775	338	
500	400	600	YES	YES	454	567	481	601	1,000	1,079	115,500	96x39x79	8,975	345	
500	450	600	NO	NO	545	681	481	601	1,200	1,214	106,750	72x39x79	6,195	318	
500	450	600	YES	NO	505	631	481	601	1,200	1,214	112,050	72x39x79	6,395	328	
500	450	600	NO	YES	551	688	481	601	1,200	1,214	124,550	96x39x79	9,095	350	
500	450	600	YES	YES	510	638	481	601	1,200	1,214	129,950	96x39x79	9,295	358	
625	500	600	NO	NO	602	753	601	752	1,400	1,349	108,950	108x39x79	7,900	270	
625	500	600	YES	NO	559	699	601	752	1,400	1,349	118,650	108x39x79	8,120	278	
625	500	600	NO	YES	609	761	601	752	1,400	1,349	128,450	120x39x79	10,580	326	
625	500	600	YES	YES	554	705	601	752	1,400	1,349	134,400	120x39x79	10,800	332	
750	600	600	NO	NO	723	903	722	902	1,600	1,619	130,700	108x39x79	8,500	291	
750	600	600	YES	NO	671	839	722	902	1,600	1,619	142,350	108x39x79	8,720	298	
750	600	600	NO	YES	730	913	722	902	1,600	1,619	154,150	120x39x79	11,580	356	
750	600	600	YES	YES	677	846	722	902	1,600	1,619	161,250	120x39x79	11,800	363	
750	675	600	NO	YES	822	1027	722	902	1,600	1,822	173,400	120x39x79	11,880	366	
750	675	600	YES	YES	762	952	722	902	1,600	1,822	181,400	120x39x79	12,100	372	
			13		1,4,5,7,8,9,11,12		2,3,5,7,8,9,11,12		6	6,8,9,11,12					

Table 6 Circuit Breaker Ratings

UPS Module	Input	Input Breaker Ratings (Amps)			Output and Bypass Breaker Ratings (Amps)		
kVA Ratings	Voltage	Frame	Trip	Interrupting (KAIC)	Frame	Trip	Interrupting (KAIC)
500 (400 kW)	480	1000	800	65	1000	900	65
500 (400 kW)	600	1000	700	42	1000	700	42
500 (450 kW)	480	1000	900	65	1000	900	65
500 (450 kW)	600	1000	700	42	1000	700	42
625 (500 kW)	480	1000	1000	65	1000	1000	65
625 (500 kW)	600	1000	800	42	1000	800	42
750 (600 kW)	480	1200	1100	65	1200	1100	65
750 (600 kW)	600	1000	1000	42	1000	1000	42
750 (675 kW)	480	1200	1200	65	1200	1100	65
750 (675 kW)	600	1200	1000	42	1200	1000	42

13.0 APPENDIX B - FIELD SUPPLIED LUGS

Table 7 One-Hole Lugs

	T & B¹ Lug Style	Wire Size	Bolt Size (Inches)	Tongue Width (Inches)	T & B¹ P/N	Liebert P/N
1	Stak-On	1/0 AWG	3/8	0.88	J973	12-714255-56
2		2/0 AWG	3/8	1.00	K973	12-714255-66
3		3/0 AWG	3/8	1.10	L973	12-714255-76
4		4/0 AWG	3/8	1.20	M973	12-714255-86
5	Color-Keyed Aluminum/ Copper	1/0 AWG	3/8	0.93	60130	—
6		2/0 AWG	3/8	0.97	60136	—
7		3/0 AWG	3/8	1.06	60142	—
8	Color-Keyed Copper Cable Long Barrel	1/0 AWG	3/8	0.75	54909BE	—
9		2/0 AWG	3/8	0.81	54910BE	—
10		3/0 AWG	1/2	0.94	54965BE	—
11		4/0 AWG	1/2	1.03	54970BE	—
12		250MCM	1/2	1.09	54913BE	—
13	Narrow-Tongue Copper Cable	350MCM	1/2	1.09	55165	—
14		500MCM	1/2	1.20	55171	—

¹ NOTE: Manufacturer Thomas & Betts (T & B), 1-800-862-8324



Series 600T™ UPS

Single Module Three Phase

500kVA to 750 kVA, 60 Hz

Technical Support

U.S.A. 1-800-222-5877
Outside the U.S.A. 614-841-6755
U.K. +44 (0) 1793 553355
France +33 1 4 87 51 52
Germany +49 89 99 19 220
Italy +39 2 98250 1
Netherlands +00 31 475 503333
E-mail upstech@liebert.com
Web site <http://www.liebert.com>
Worldwide FAX 614-841-5471
tech support

The Company Behind The Products

With more than 500,000 installations around the globe, Liebert is the world leader in computer protection systems. Since its founding in 1965, Liebert has developed a complete range of support and protection systems for sensitive electronics:

- Environmental systems: close-control air conditioning from 1.5 to 60 tons.
- Power conditioning and UPS with power ranges from 250 VA to more than 1000 kVA.
- Integrated systems that provide both environmental and power protection in a single, flexible package.
- Monitoring and control — on-site or remote — from systems of any size or location

Service and support, through more than 100 service centers around the world, and a 24-hour Customer Response Center.

While every precaution has been taken to ensure accuracy and completeness of this literature, Liebert Corporation assumes no responsibility, and disclaims all liability for damages resulting from use of this information or for any errors or omissions.

© 2000 Liebert Corporation. All rights reserved throughout the world. Specifications subject to change without notice.

® Liebert and the Liebert logo are registered trademarks of Liebert Corporation. All names referred to are trademarks or registered trademarks of their respective owners.

Printed in U.S.A.

SL-30527