

DISCONTINUED  
PRODUCT

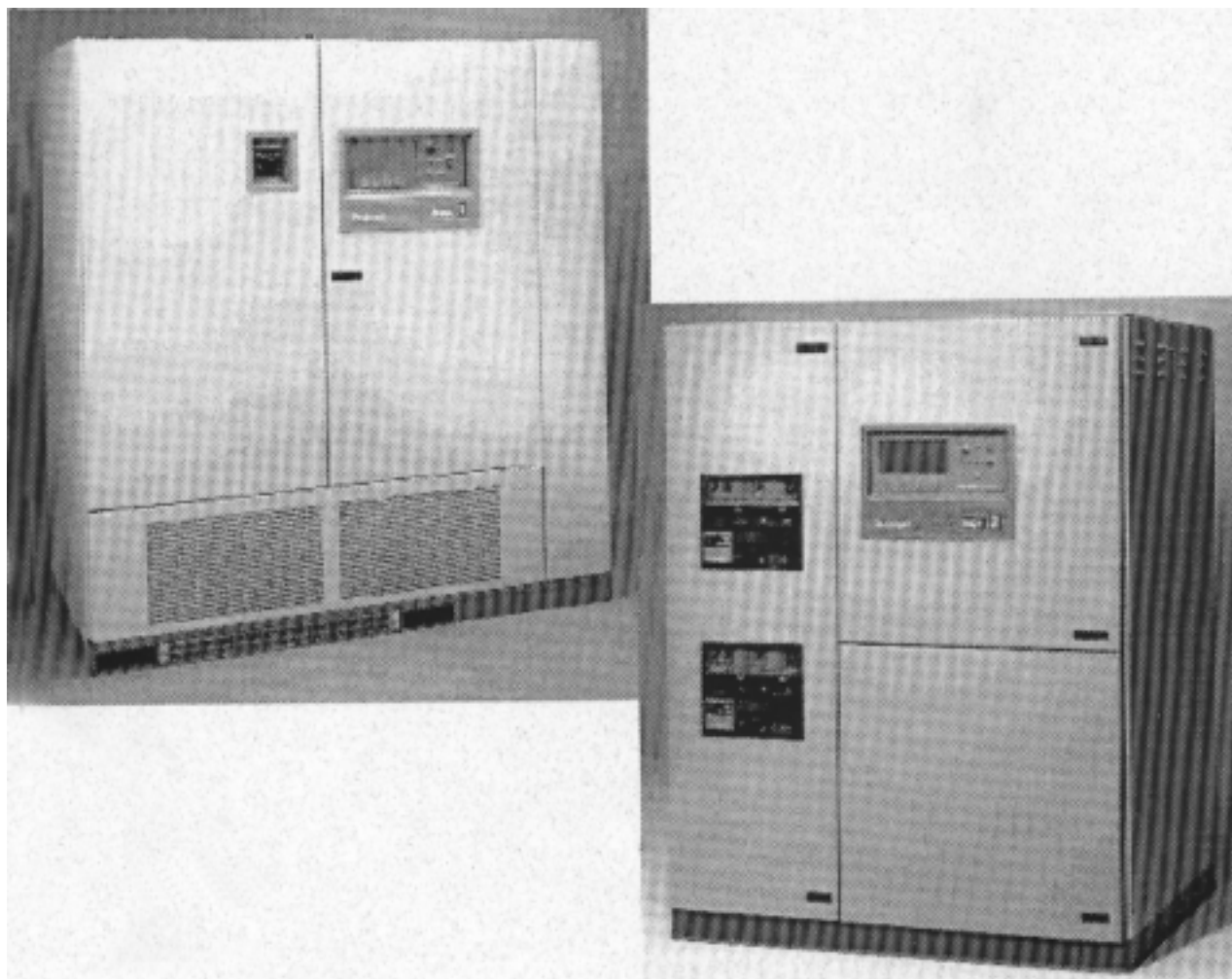


POWER PROTECTION

# Series 600T™ UPS

Multi-Module Three Phase  
300 kVA to 450 kVA; 60 Hz

Installation  
Manual



---

---

**DISCONTINUED  
PRODUCT**

---

## TABLE OF CONTENTS

<b>IMPORTANT SAFETY INSTRUCTIONS</b> .....	<b>1</b>
<b>1.0 SAFETY PRECAUTIONS</b> .....	<b>3</b>
<b>2.0 INSTALLATION CONSIDERATIONS</b> .....	<b>4</b>
<b>3.0 UNLOADING AND HANDLING</b> .....	<b>6</b>
<b>4.0 INSPECTIONS</b> .....	<b>7</b>
4.1 External Inspections .....	7
4.2 Internal Inspections .....	7
<b>5.0 EQUIPMENT LOCATION</b> .....	<b>8</b>
<b>6.0 BATTERY INSTALLATION</b> .....	<b>9</b>
6.1 Battery Safety Precautions .....	9
6.2 Battery Cabinets .....	14
6.3 Non-Standard Batteries .....	14
<b>7.0 OPTIONAL TRANSFORMER CABINET</b> .....	<b>15</b>
<b>8.0 WIRING CONSIDERATIONS</b> .....	<b>16</b>
8.1 Power and Control Wiring .....	17
8.2 Battery Wiring .....	17
<b>9.0 WIRING CONNECTIONS</b> .....	<b>20</b>
<b>10.0 WIRING INSPECTION</b> .....	<b>22</b>
<b>11.0 APPENDIX A - SITE PLANNING DATA</b> .....	<b>50</b>
11.1 Notes .....	50
<b>12.0 APPENDIX B - FIELD SUPPLIED LUGS</b> .....	<b>54</b>

---

## FIGURES

Figure 1	Multi-Module 300 to 450 kVA UPS	5
Figure 2	UPS Multi-Module Unit Block Diagram	12
Figure 3	System Control Cabinets	13
Figure 4	Typical Multi-Module Configurations	18
Figure 5	Outline Drawing, 300 to 450 kVA Multi-Module UPS, 480 or 600 VAC Input	24
Figure 6	Outline Drawing, 375 kVA with 208 VAC Input, or All Other 300 to 450 kVA UPS With Optional Transformer Cabinet	25
Figure 7	Outline Drawing, Optional Transformer Cabinet	26
Figure 8	Outline Drawing, System Control Cabinet (SCCB) 640 to 800 Amps	27
Figure 9	Outline Drawing, System Control Cabinet (SCCB) 1280 to 1600 Amps	28
Figure 10	Outline Drawing, System Control Cabinet (SCCP) 200 to 480 Amps	29
Figure 11	Outline Drawing, System Control Cabinet (SCCP) 560 to 960 Amps	30
Figure 12	Outline Drawing, System Control Cabinet (SCCP) 1120 to 2000 Amps	31
Figure 13	Base Mounting Patterns, 300 to 450 kVA UPS Modules	32
Figure 14	Base Mounting Patterns, System Control Cabinet (SCCB) 640 to 3000 Amps	33
Figure 15	Base Mounting Patterns, System Control Cabinet (SCCP) 200 to 480 Amps	34
Figure 16	Base Mounting Patterns, System Control Cabinet (SCCP) 560 to 2000 Amps	35
Figure 17	Bussing Details, Modules With 480 and 600 VAC Output	36
Figure 18	Bussing Details, Modules With 208 VAC Output	37
Figure 19	Outline Drawing, Battery Cabinet, Size A	38
Figure 20	Outline Drawing, Battery Cabinet, Size B	39
Figure 21	Installation Drawing, Parallel Battery Cabinets	40
Figure 22	One-Line Diagram, 2-Module Parallel System With 2-Breaker Maintenance Bypass	41
Figure 23	One-Line Diagram, 4-Module Parallel System With 3-Breaker Maintenance Bypass	42
Figure 24	Control Wiring Interconnect Diagram	43
Figure 25	Control Connection Location Diagram, Multi-Module Unit	44
Figure 26	Control Connection Location Diagram, System Control Cabinet	45
Figure 27	Video Display Terminal Wiring	46
Figure 28	Module Battery Disconnect, Systems With Isolation Transformer	47
Figure 29	Module Battery Disconnect, Systems Without Isolation Transformer	48
Figure 30	Remote Status Panel	49

## TABLES

Table 1	Power Wiring Terminals - Factory Supplied	22
Table 2	Torque Specifications	22
Table 3	Table 310-16	23
Table 4	Series 600T Multi-Module Systems - 208 Volt Input	51
Table 5	Series 600T Multi-Module Systems, 300-450 kVA - 480 Volt Input	51
Table 6	Series 600T Multi-Module Systems, 600 Volt Input	52
Table 7	Battery Pack	52
Table 8	UPS Efficiency, All kVA / kW Ratings	52
Table 9	System Control Cabinets	53
Table 10	One-Hole Lugs	54

---

## IMPORTANT SAFETY INSTRUCTIONS

---

### Save These Instructions.

This manual contains important instructions that should be followed during installation of your Series 600T UPS and batteries.



#### **WARNING**

**EXERCISE EXTREME CARE WHEN HANDLING UPS CABINETS TO AVOID EQUIPMENT DAMAGE OR INJURY TO PERSONNEL. THE UPS MODULE WEIGHT RANGES FROM 4150 POUNDS (1885 KG) TO 9120 POUNDS (4145 KG), INCLUDING TRANSFORMER CABINET. THE BATTERY CABINETS WEIGH BETWEEN 3000 POUNDS (1364 KG) AND 4900 POUNDS (2227 KG).**

**LOCATE CENTER OF GRAVITY SYMBOLS BEFORE HANDLING EACH CABINET. TEST LIFT AND BALANCE THE CABINETS BEFORE TRANSPORTING. MAINTAIN MINIMUM TILT FROM VERTICAL AT ALL TIMES.**

**SLOTS AT THE BASE OF THE MODULE AND BATTERY CABINETS ARE INTENDED FOR FORKLIFT LIFT USE. BASE SLOTS WILL SUPPORT THE UNIT ONLY IF THE FORKS ARE COMPLETELY BENEATH THE UNIT.**

**SYSTEM CONTROL CABINETS (SCC'S) HAVE HOLES INTENDED FOR RIGGING BARS OR CHAINS. PREVENT CHAINS OR CABLES FROM CONTACTING CABINET BY USING SPREADER BAR AND ADEQUATE PADDING.**

**FOLLOW ALL BATTERY SAFETY PRECAUTIONS WHEN INSTALLING, CHARGING, OR SERVICING BATTERIES. IN ADDITION TO THE HAZARD OF ELECTRIC SHOCK, GAS PRODUCED BY BATTERIES CAN BE EXPLOSIVE AND SULFURIC ACID CAN CAUSE SEVERE BURNS.**

**IN CASE OF FIRE INVOLVING ELECTRICAL EQUIPMENT, ONLY CARBON DIOXIDE FIRE EXTINGUISHERS, OR THOSE APPROVED FOR USE IN ELECTRICAL FIRE FIGHTING, SHOULD BE USED.**

**EXTREME CAUTION IS REQUIRED WHEN PERFORMING MAINTENANCE.**

**BE CONSTANTLY AWARE THAT THE UPS SYSTEM CONTAINS HIGH DC AS WELL AS AC VOLTAGES.**

**CHECK FOR VOLTAGE WITH BOTH AC AND DC VOLTMETERS PRIOR TO MAKING CONTACT.**



**WARNING**

**LOCATE CENTER OF GRAVITY SYMBOLS  
AND DETERMINE UNIT WEIGHT  
BEFORE HANDLING CABINET.**



If you require assistance for any reason, call the toll-free Liebert Customer Service & Support number; 1-800-543-2378. For CS&S to assist you expediently, please have the following information available:

Part Numbers: \_\_\_\_\_  
Serial Numbers: \_\_\_\_\_  
kVA Rating: \_\_\_\_\_  
Date Purchased: \_\_\_\_\_  
Date Installed: \_\_\_\_\_  
Location: \_\_\_\_\_  
Input Voltage: \_\_\_\_\_  
Output Voltage: \_\_\_\_\_  
Battery Reserve Time: \_\_\_\_\_

---

## 1.0 SAFETY PRECAUTIONS

---

Read this manual thoroughly, paying special attention to the sections that apply to you, before working with the UPS. **Retain this manual for use by installing personnel.**

Under typical operation and with all UPS doors closed, only normal safety precautions are necessary. The area around the UPS system should be kept free from puddles of water, excess moisture, or debris.

Special safety precautions are required for procedures involving handling, installation, and maintenance of the UPS system or the battery. Observe all safety precautions in this manual before handling or installing the UPS system. Observe all precautions in the **Operation and Maintenance Manual**, before as well as during performance of all maintenance procedures. Observe all battery safety precautions before working on or near the battery.

**This equipment contains several circuits that are energized with high voltage.** Only test equipment designated for troubleshooting should be used. This is particularly true for oscilloscopes. Always check with an AC and DC voltmeter to ensure safety before making contact or using tools. Even when the power is turned Off, dangerously high potentials may exist at the capacitor banks and at the batteries.

**ONLY qualified service personnel should perform maintenance on the UPS system.** When performing maintenance with any part of the equipment under power, service personnel and test equipment should be standing on rubber mats. The service personnel should wear insulating shoes for isolation from direct contact with the floor (earth ground).

Unless all power is removed from the equipment, one person should never work alone. A second person should be standing by to assist and summon help in case an accident should occur.

Four types of messages are used throughout the manual to stress important text. Carefully read the text below each Danger, Warning, Caution, and Note and use professional skills and prudent care when performing the actions described by that text.

A **Danger** signals immediate hazards resulting in severe personal injury or death. For example:



### **DANGER**

**A DANGER SIGNALS IMMEDIATE HAZARDS WHICH WILL RESULT IN SEVERE PERSONAL INJURY OR DEATH.**

A **Warning** signals the presence of a possible serious, life-threatening condition. For example:



### **WARNING**

**LETHAL VOLTAGES MAY BE PRESENT SENT WITHIN THIS UNIT EVEN WHEN IT IS APPARENTLY NOT OPERATING. OBSERVE ALL CAUTIONS AND WARNINGS IN THIS MANUAL. FAILURE TO DO SO COULD RESULT IN SERIOUS INJURY OR DEATH. DO NOT WORK ON OR OPERATE THIS EQUIPMENT UNLESS YOU ARE FULLY QUALIFIED TO DO SO!! NEVER WORK ALONE.**

A **Caution** indicates a condition that could seriously damage equipment and possibly injure personnel. For example:



### **CAUTION**

**Extreme care is necessary when removing shoring braces. Do not strike the cabinet with hammers or other tools.**

A **Note** emphasizes important text. If the note is not followed, equipment could be damaged or may not operate properly. For example:



### **NOTE**

*If the UPS system has a blown fuse, the cause should be determined before you replace the fuse. Contact Liebert Customer Service and Support.*

---

## 2.0 INSTALLATION CONSIDERATIONS

---

Install your Series 600T UPS in accordance with the submittal drawing package and the following procedures.

A Liebert authorized representative must perform the initial system check-out and start-up to ensure proper system operation. Equipment warranties will be voided unless system start-up is performed by a Liebert authorized representative. Contact your local Liebert sales representative or Liebert Customer Service and Support at **1-800-543-2378** to arrange for system start-up.



### CAUTION

**Read this manual thoroughly before attempting to wire or operate the unit. Improper installation is the most significant cause of UPS start-up problems.**

**Do not install this equipment near gas or electric heaters. It is preferable to install the UPS in a restricted location to prevent access by unauthorized personnel.**

1. Proper planning will speed unloading, location, and connection of the UPS. Refer to **Figure 5** through **Figure 30** and **Appendix A - Site Planning Data**.
2. Refer to information later in this manual regarding the optional Battery Cabinets and Transformer Cabinets. **Observe all battery safety precautions when working on or near the battery.**
3. Use the shortest output distribution cable runs possible, consistent with logical equipment arrangements and with allowances for future additions if planned.
4. Recommended ambient operating temperature is 25°C (77°F). Relative humidity must be less than 95%, non-condensing. Note that room ventilation is necessary, but air conditioning may not be required. Maximum ambient operating temperature is 40°C (104°F) without derating. The batteries should not exceed 25°C (77°F). At elevations above 4,000 feet (1219 meters) derating may be required (consult your Liebert sales representative).
5. Even though your Liebert UPS unit is 92.5 to 94% efficient, the heat output is substantial. For more specific information, see **Appendix A - Site Planning Data**. Be sure environmental conditioning systems can accommodate this BTU load, even during utility outages.
6. The routing (inside the facility) to the installation site, as well as the floor at the final equipment location, must be capable of supporting the cabinet weight and the weight of any moving equipment. The modules weigh between 4150 and 7920 pounds, not including transformer cabinets. The battery cabinets weigh between 3100 and 5100 pounds. The System Control Cabinets weigh between 1000 and 2550 pounds. Refer to **Appendix A - Site Planning Data**.
7. Plan the routing to ensure that the unit can move through all aisleways, doorways, and around corners without risking damage. If the modules and batteries must be moved by elevator, check the size of the door openings and the weight-carrying capacity of the elevator.





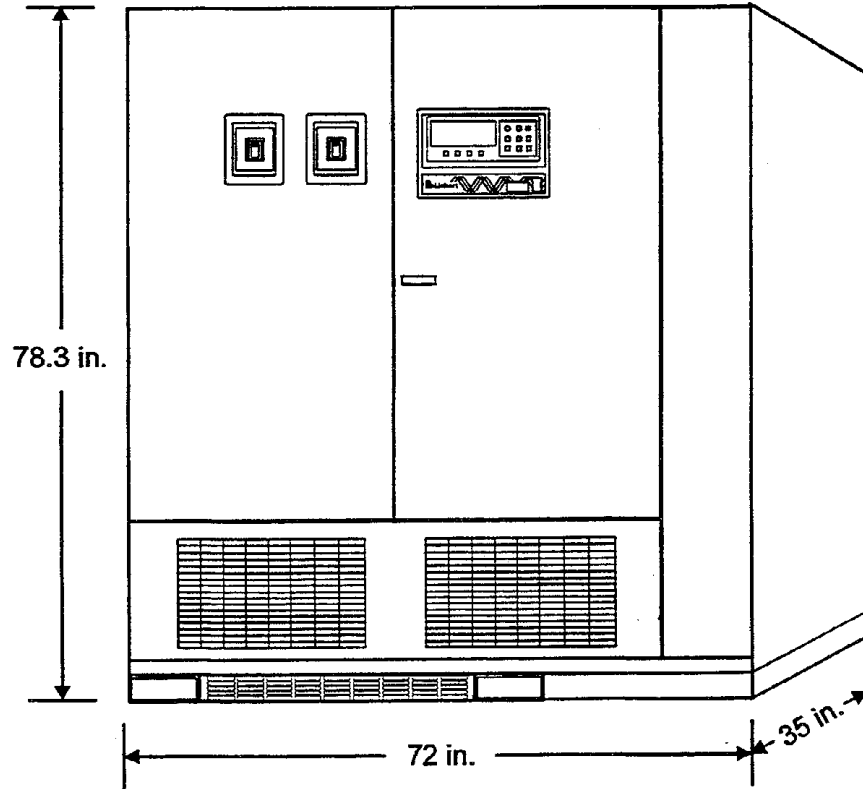
**WARNING**

**LOCATE CENTER OF GRAVITY SYMBOLS AND DETERMINE UNIT WEIGHT BEFORE HANDLING CABINET.**



**Figure 1 Multi-Module 300 to 450 kVA UPS**

Note: The 375 kVA UPS with 208 VAC input measures 96x35x78.3 inches.



---

## 3.0 UNLOADING AND HANDLING

---

The UPS module is shipped in one cabinet to allow easy handling at the site. Because the weight distribution in the cabinet is uneven, use extreme care during handling and transport. Your installation may also include Battery Cabinets and a System Control Cabinet.



### **WARNING**

**EXERCISE EXTREME CARE WHEN HANDLING UPS CABINETS TO AVOID EQUIPMENT DAMAGE OR INJURY TO PERSONNEL. THE UPS MODULE WEIGHT RANGES FROM 4150 POUNDS TO 7920 POUNDS, NOT INCLUDING TRANSFORMER CABINETS. BATTERY CABINETS WEIGH BETWEEN 3100 AND 5100 POUNDS.**

**LOCATE CENTER OF GRAVITY SYMBOLS BEFORE HANDLING CABINET. TEST LIFT AND BALANCE THE CABINET BEFORE TRANSPORTING. MAINTAIN MINIMUM TILT FROM VERTICAL AT ALL TIMES.**

**SLOTS AT THE BASE OF THE MODULES AND BATTERY CABINETS ARE INTENDED FOR LIFT USE. BASE SLOTS WILL SUPPORT THE UNIT ONLY IF THE FORKS ARE COMPLETELY BENEATH THE UNIT.**

**SYSTEM CONTROL CABINETS (SCC'S) HAVE HOLES INTENDED FOR RIGGING BARS OR CHAINS. PREVENT CHAINS OR CABLES FROM CONTACTING CABINET BY USING SPREADER BAR AND ADEQUATE PADDING.**

To reduce the possibility of shipping damage, cabinets are shored with 2x4 bracing, secured with screw-type nails. This shoring must be carefully removed prior to unloading.



### **CAUTION**

**EXTREME CARE IS NECESSARY WHEN REMOVING SHORING BRACES. DO NOT STRIKE CABINET WITH HAMMERS OR OTHER TOOLS.**

---

## 4.0 INSPECTIONS

---

### 4.1 External Inspections

1. While the UPS system is still on the truck, inspect the equipment and shipping container(s) for any signs of damage or mishandling. Do not attempt to install the system if damage is apparent. If any damage is noted, file a damage claim with the shipping agency within 24 hours and contact Liebert Customer Service and Support at 1-800-543-2378 to inform them of the damage claim and the condition of the equipment.
2. Locate the bag containing the keys for the front access door. The bag is attached to the cabinet.
3. Compare the contents of the shipment with the bill of lading. Report any missing items to the carrier and to Liebert Customer Service and Support immediately.
4. Check the nameplate on the cabinets to verify that the model numbers correspond with the one specified. Record the model numbers and serial numbers in the front of this installation manual. A record of this information is necessary should servicing become required.

### 4.2 Internal Inspections

1. Verify that all items have been received.
2. If spare parts were ordered, verify arrival.
3. Open doors and remove cabinet panels to check for shipping damage to internal components.
4. Check for loose connections or unsecured components in the cabinet(s).
5. Check for installation of circuit breaker line safety shields. There should be no exposed circuit breaker terminals when the cabinet doors are opened.
6. Check for any unsafe condition that may be a potential safety hazard.
7. UPS modules are shipped with internally mounted shipping brackets. The shipping brackets (painted orange) must be removed from the rear (remove rear panels).

---

## 5.0 EQUIPMENT LOCATION

---

1. Handle cabinet(s) in accordance with **WARNINGS** in **3.0 - Unloading and Handling**. Use a suitable material handling device to move cabinet to its final location. Exercise extreme care because of the uneven weight distribution. Carefully lower the cabinet to the floor.
2. Verify that the UPS system is installed in a clean, cool and dry location.
3. Installation and serviceability will be easier if adequate access is provided on all sides of the equipment, but only front access is required.
  - a. Verify that there is adequate clearance to open cabinet doors. See drawings and local codes (4 feet is recommended).
  - b. Verify that there is adequate area in front of circuit breakers to perform maintenance. Check installation drawings for location of breakers. Check with local codes.
  - c. Verify that there is adequate clearance above all cabinets to allow exhaust air to flow without restriction (2 feet minimum, unobstructed).

---

## 6.0 BATTERY INSTALLATION

---

### 6.1 Battery Safety Precautions

Servicing of batteries should be performed or supervised by personnel knowledgeable of batteries and the required precautions. Keep unauthorized personnel away from batteries.

When replacing batteries, use the same number and type of batteries.



#### **CAUTION**

**Lead-acid batteries contain hazardous materials. Batteries must be handled, transported, and recycled or discarded in accordance with federal, state, and local regulations. Because lead is a toxic substance, lead-acid batteries should be recycled rather than discarded.**

**Do not open or mutilate the battery or batteries. Released electrolyte is harmful to the skin and eyes. It may be toxic. Do not dispose of battery or batteries in a fire. The battery may explode.**

**A battery can present a risk of electrical shock and high short circuit current. The following precautions should be observed when working on batteries**

- 1. Remove watches, rings, or other metal objects.**
- 2. Use tools with insulated handles.**
- 3. Wear rubber gloves and boots.**
- 4. Do not lay tools or metal parts on top of batteries.**
- 5. Disconnect charging source prior to connecting or disconnecting battery terminals.**
- 6. Determine if battery is inadvertently grounded. If inadvertently grounded, remove source of ground. Contact with any part of a grounded battery can result in electrical shock. The likelihood of such shock will be reduced if such grounds are removed during installation and maintenance.**

**Lead-acid batteries can present a risk of fire because they generate hydrogen gas. The following procedures should be followed:**

- 1. DO NOT SMOKE when near batteries.**
- 2. DO NOT cause flame or spark in battery area.**
- 3. Discharge static electricity from body before touching batteries by first touching a grounded metal surface.**

---

## Battery Safety Precautions in French Per CSA Requirements

### Instructions Importantes Concernant La Sécurité

#### Conserver Ces Instructions



#### ADVERTISSEMENT

DES PIÈCES SOUS ALIMENTATION SERONT LAISSÉES SANS PROTECTION DURANT CES PROCÉDURES D'ENTRETIEN. UN PERSONNEL QUALIFIÉ EST REQUIS POUR EFFECTUER CES TRAVAUX.

LES FUSIBLES A C.C. DE LA BATTERIE D'ACCUMULATEURS OPÈRENT EN TOUT TEMPS A LA TENSION NOMINALE. LA PRÉSENCE D'UN FUSIBLE A C.C. BRÛLÉ INDIQUE UN PROBLÈME SÉRIEUX. LE REMPLACEMENT DE CE FUSIBLE, SANS AVOIR DÉTERMINÉ LES RAISONS DE LA DÉFECTUOSITÉ, PEUT ENTRAÎNER DES BLESSURES OU DES DOMMAGES SÉRIEUX À L'ÉQUIPEMENT. POUR ASSISTANCE, APPELER LE DÉPARTEMENT DE SERVICE À LA CLIENTÈLE DE LIEBERT.



#### DANGER

Les accumulateurs plomb-acide contiennent de la matière comportant un certain risque. Les accumulateurs doivent être manipulés, transportés et recyclés ou éliminés en accord avec les lois fédérales, provinciales et locales. Parce que le plomb est une substance toxique, les accumulateurs plomb-acide devraient être recyclés plutôt qu'éliminés.

Il ne faut pas brûler le ou les accumulateurs. L'accumulateur pourrait alors exploser.

Il ne faut pas ouvrir ou endommager le ou les accumulateurs. L'électrolyte qui pourrait s'en échapper est dommageable pour la peau et les yeux.

Un accumulateur représente un risque de choc électrique et de haut courant de court-circuit. Lorsque des accumulateurs sont manipulés, les mesures préventives suivantes devraient être observées:

1. Retirer toutes montres, bagues ou autres objets métalliques.
2. Utiliser des outils avec manchon isolé.
3. Porter des gants et des bottes de caoutchouc.
4. Ne pas déposer les outils ou les pièces métalliques sur le dessus des accumulateurs.
5. Interrompre la source de charge avant de raccorder ou de débrancher les bornes de la batterie d'accumulateurs.
6. Déterminer si l'accumulateur est mis à la terre par erreur. Si oui, défaire cette mise à la terre. Tout contact avec un accumulateur mis à la terre peut se traduire en un choc électrique. La possibilité de tels chocs sera réduite si de telles mises à la terre sont débranchées pour la durée de l'installation ou de l'entretien.

---

Les accumulateurs plomb-acide présentent un risque d'incendie parce qu'ils génèrent des gaz à l'hydrogène. Les procédures suivantes devront être respectées.

1. **NE PAS FUMER** lorsque près des accumulateurs.
2. **NE PAS** produire de flammes ou d'étincelles près des accumulateurs.
3. Décharger toute électricité statique présente sur votre corps avant de toucher un accumulateur en touchant d'abord une surface métallique mise à la terre.



**DANGER**

L'électrolyte est un acide sulfurique dilué qui est dangereux au contact de la peau et des yeux. Ce produit est corrosif et aussi conducteur électrique. Les procédures suivantes devront être observées:

1. Porter toujours des vêtements protecteurs ainsi que des lunettes de protection pour les yeux.
2. Si l'électrolyte entre en contact avec la peau, nettoyer immédiatement en rinçant avec de l'eau.
3. Si l'électrolyte entre en contact avec les yeux, arroser immédiatement et généreusement avec de l'eau. Demander pour de l'aide médicale.
4. Lorsque l'électrolyte est renversée, la surface affectée devrait être nettoyée en utilisant un agent neutralisant adéquat. Une pratique courante est d'utiliser un mélange d'approximativement une livre (500 grammes) de bicarbonate de soude dans approximativement un gallon (4 litres) d'eau. Le mélange de bicarbonate de soude devra être ajouté jusqu'à ce qu'il n'y ait plus apparence de réaction (mousse). Le liquide résiduel devra être nettoyé à l'eau et la surface concernée devra être asséchée.

Figure 2 UPS Multi-Module Unit Block Diagram

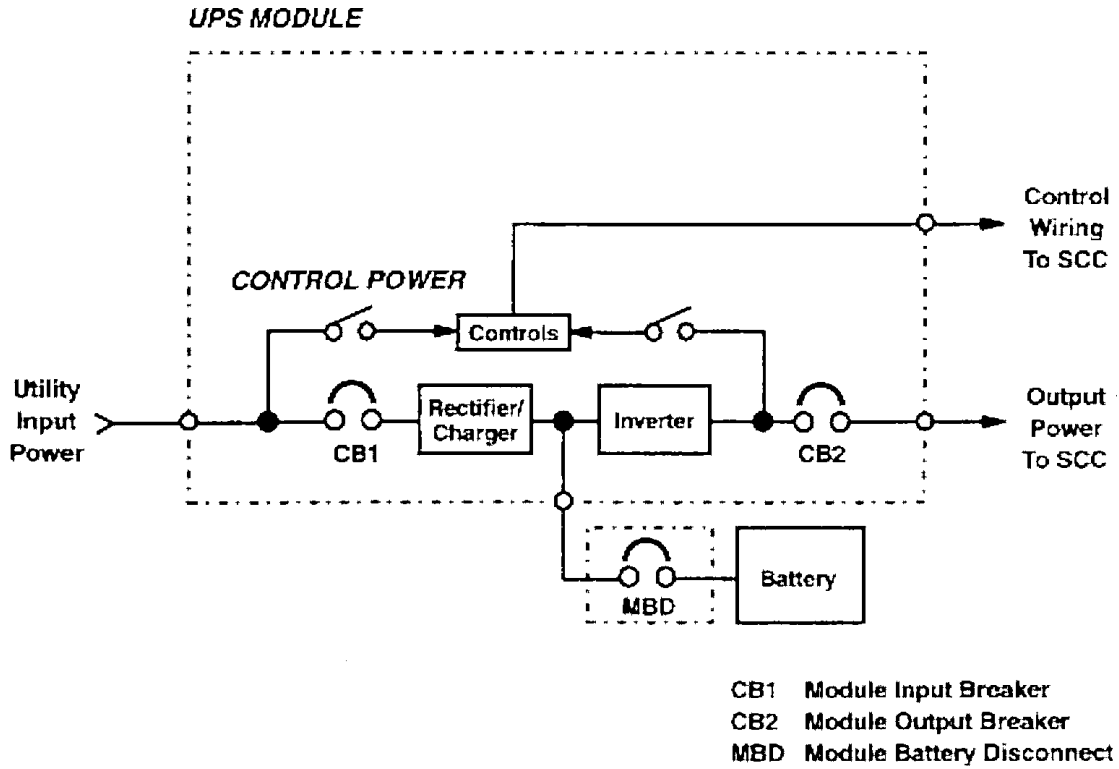
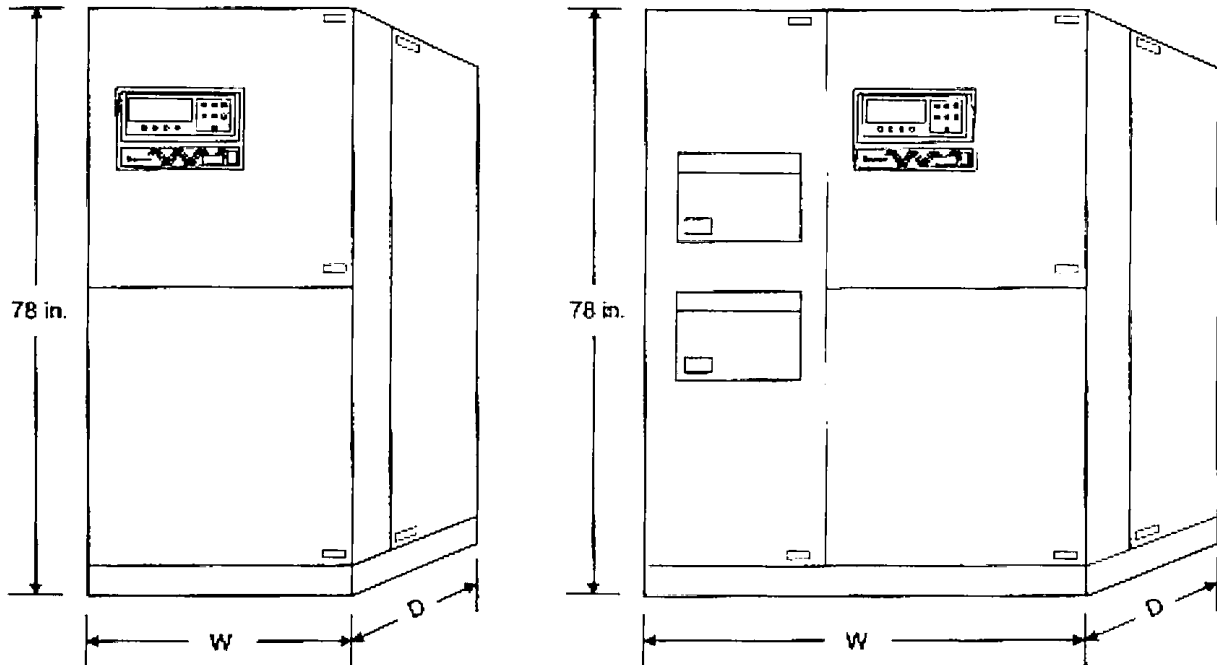




Figure 3 System Control Cabinets



**SCCP Dimensions**

Amps	W x D (Inches)	Weight (lbs.)
2000	37 x 50	1400
1120-1600	37 x 50	1250
560-960	37 x 37	1000
200-480	37 x 33	1000

**SCCB Dimensions**

Amps	W x D (Inches)	Weight (lbs.)
4000	132 x 60	4880
2000-3000	61 x 50	2370
1280-1600	60 x 50	2000
640-800	37 x 37	1100

**TYPES OF SYSTEM CONTROL CABINETS (SCC)**

- SCCB** A stand **alone** cabinet containing system control logic for up to six UPS modules, static bypass switch, manually operated disconnects for static bypass switch, and two motor operated system circuit breakers.
- SCCC** An **integrated** configuration (like SCCI) with the static bypass switch rated for **continuous** duty.
- SCCI** System control logic and static bypass switch are **integrated** into a switchboard cabinet manufactured by others, which also includes the system circuit breakers.
- SCCP** A stand alone cabinet similar to SCCB except smaller in and designed for two UPS modules (a **pair**). Current range is 200 to 2000 amperes.

---

## 6.2 Battery Cabinets

Two sizes of optional battery cabinets are available. Refer to **Figure 19** through **Figure 21**. The battery cabinet cells range from 90 to 150 Ampere-hours. The same model battery cabinet may be paralleled in multiple cabinet strings for additional capacity. Battery capacity (in minutes) at your installation will depend on cabinet model, number of cabinets, and amount of critical load on the UPS.



### NOTE

*Battery cabinets are 33 inches deep, compared to 35 inches deep for the 300-450 kVA UPS modules. They may be installed adjacent to the UPS module, but will not be an exact bolt-up match, as would be the case with 150-225 kVA modules.*

1. **Handling.** The Battery Cabinet weighs 3100 to 5100 pounds. Forklift slots are provided for easy handling.
2. **Cabinet Inspection.** Remove all panels and visually inspect the batteries, bus connections, and cabinet for any damage. **Exercise caution; voltage is present within the Battery Cabinet even before installation.** If there are signs of damage, do not proceed. Call Liebert Customer Service and Support at 1-800-542-2378.
3. **Battery Storage.** The batteries used in the Battery Cabinet have an excellent charge retaining characteristic. The batteries can be stored for up to six months without any appreciable deterioration. Self-discharge rate of the batteries is approximately 3% per month when the batteries are stored in temperatures of 45°C to 45°C (59°F to 77°F). If the Battery Cabinet is planned to be stored for longer than six months, contact Liebert Customer Service for recommended action.
4. **Installation.** The Battery Cabinet(s) can be located conveniently next to each UPS module. The front-access-only-design eliminates side and rear service clearance requirements.
  - **Environment.** Locate the Battery Cabinet in a clean, dry environment. Recommended temperature range for optimum performance and lifetime is 20°C (68°F) to 25°C (77°F).
  - **Service Clearance.** Allow front access to the Battery Cabinet at all times for maintenance and servicing. Electrical codes require that the Battery Cabinet be installed with no less than 3 feet (1 meter) of clearance at the front of the cabinet when operating. Side and rear panels do not require service clearance.
  - **Side Panels.** Remove protective side panels to connect cabinets together. Panels are retained at the bottom with three screws.
  - **Shield Plate.** The shield plate in each Battery Cabinet should be on the side toward the UPS module for proper UPS ventilation. Move the shield if required by your Battery Cabinet location.
  - **Cables.** Cables may be run between the cabinets through cutouts in the top of the cabinet, eliminating the need for external conduit runs. **Route cables before moving cabinets into final position for bolting together.** Remove top panels for access, if required. No top or bottom entry cables are required, except for remotely located cabinets which require conduits. Refer to **Figure 19** through **Figure 21**.

## 6.3 Non-Standard Batteries

When batteries other than a matching Battery Cabinet are used, a remote battery disconnect switch with overcurrent protection is required per the National Electrical Code. Refer to **Figure 28** and **Figure 29**. Contact your Liebert sales representative regarding this option.

1. Install battery racks/cabinets and batteries per manufacturer's installation and maintenance instructions.
2. Verify battery area has adequate ventilation and battery operating temperature complies with manufacturer's specification.

If you have any questions concerning batteries, battery racks, or accessories, contact Liebert Customer Service and Support at **1-800-543-2378**.

---

## 7.0 OPTIONAL TRANSFORMER CABINET

---

The optional transformer cabinet is a free-standing enclosure that must be bolted to the right side of the UPS module. Forklift slots are included in the cabinet base for easy handling. Power and control cables for UPS system interconnections are provided with each cabinet. Refer to **Figure 6** and **Figure 7**.

The optional Transformer Cabinet (**Figure 7**) encloses the Rectifier Isolation Transformer and the optional Bypass Isolation Transformer. The cabinet is cooled by fans, with a disposable filter at the bottom.

---

## 8.0 WIRING CONSIDERATIONS

---



### WARNING

**ALL POWER CONNECTIONS MUST BE COMPLETED BY A LICENSED ELECTRICIAN THAT IS EXPERIENCED IN WIRING THIS TYPE OF EQUIPMENT. WIRING MUST BE INSTALLED IN ACCORDANCE WITH ALL APPLICABLE NATIONAL AND LOCAL ELECTRICAL CODES. IMPROPER WIRING MAY CAUSE DAMAGE TO THE EQUIPMENT OR INJURY TO PERSONNEL.**

**VERIFY THAT ALL INCOMING HIGH AND LOW VOLTAGE POWER CIRCUITS ARE DE-ENERGIZED AND LOCKED OUT BEFORE INSTALLING CABLES OR MAKING ANY ELECTRICAL CONNECTIONS.**

Refer to **Appendix A - Site Planning Data** and installation drawings (**Figure 5** through **Figure 30**). Determine AC currents for your system (kVA, voltage, and options). Also refer to equipment nameplate for the model number, rating, and voltage. Refer to **Table 1** and **Table 2** for wire termination data.



### NOTE

*Use 75°C copper wire. Select wire size based on the ampacities in **Table 3** of this manual, a reprint of Table 310-16 and associated notes of the National Electrical Code (NFPA 70).*



### CAUTION

**The weight of power cables must be adequately supported to avoid stress on bus bars and lugs. In addition to weight support, the following restraining method is recommended to control cable movement during external fault conditions. Wrap line cables together at 6 inches and 12 inches from the terminals with 5 wraps of 3/8 inch nylon rope or equivalent (tensile strength of 2000 pounds). Support remainder of cable with 5 wraps every 6 inches or 1 wrap every 1 inch.**

---

## 8.1 Power and Control Wiring

1. Power wiring must be run in individual, separate conduits or cable trays. Control wiring must be stranded and run in individual separate steel conduits.



### CAUTION

**Power and control wiring must be separated!**

2. Observe local, state and national electrical codes. Verify utility power and its overcurrent protection rating will accommodate the UPS input rating, including battery recharging.
3. A safety ground wire must be run from building ground to ground point in the UPS Module Cabinet and Battery Cabinet. The grounding conductor shall comply with the following conditions of installation:
  - a. An insulated grounding conductor that is sized in accordance with the NEC and local codes and is green (with or without one or more yellow stripes) is to be installed as part of the branch circuit that supplies the unit or system.
  - b. The grounding conductor described above is to be grounded to earth at the service equipment or, if supplied by a separately derived system, at the supply transformer or motor-generator set.
  - c. The attachment-plug receptacles in the vicinity of the unit or system are all to be of a grounding type, and the grounding conductors serving these receptacles are to be connected to earth ground at the service equipment.
4. When possible, input to the UPS and bypass should be four wire plus ground. When input is straight delta, the UPS artificial neutral kit should be ordered. When input is corner-grounded delta, the isolated neutral kit should be ordered.
5. Observe clockwise phase rotation of all power wiring. Phase A leads Phase B leads Phase C. A qualified electrician should check the phase rotation.
6. NEC Class I wiring methods are required for control and communication Class 2 circuits.

## 8.2 Battery Wiring

Power wiring to the Battery Cabinet connects positive, negative, and ground power cables from the Battery Cabinet to the associated UPS. Connection of the UPS to the Battery Cabinet serves to both charge and discharge the batteries (when needed). The battery disconnect (circuit breaker) requires a control cable. Power and control cables are field supplied. Refer to **Figure 19** through **Figure 21**.



### DANGER

**A BATTERY INTERCELL CONNECTION ON EACH TIER IS DISCONNECTED FOR SAFETY DURING SHIPMENT. DO NOT COMPLETE THESE CONNECTIONS. THE LIEBERT CUSTOMER SERVICE REPRESENTATIVE WILL COMPLETE THESE CONNECTIONS AS PART OF START-UP. AN IMPROPERLY INSTALLED UNIT CAN RESULT IN INJURY TO PERSONNEL OR DAMAGE TO EQUIPMENT.**



### CAUTION

**Be sure polarity is correct when wiring the Battery Cabinet to the connected equipment (positive to positive; negative to negative). If polarity is not correct, fuse failures or equipment damage can result.**

Call Liebert Customer Service and Support to schedule installation check-out, final battery inter-cell connections, and start-up.



### NOTE

*A Liebert Battery Specialist can perform a detailed inspection of the entire battery system to ensure it meets current IEEE standards. This inspection service is recommended because batteries are a very critical part of the UPS system.*

Figure 4 Typical Multi-Module Configurations

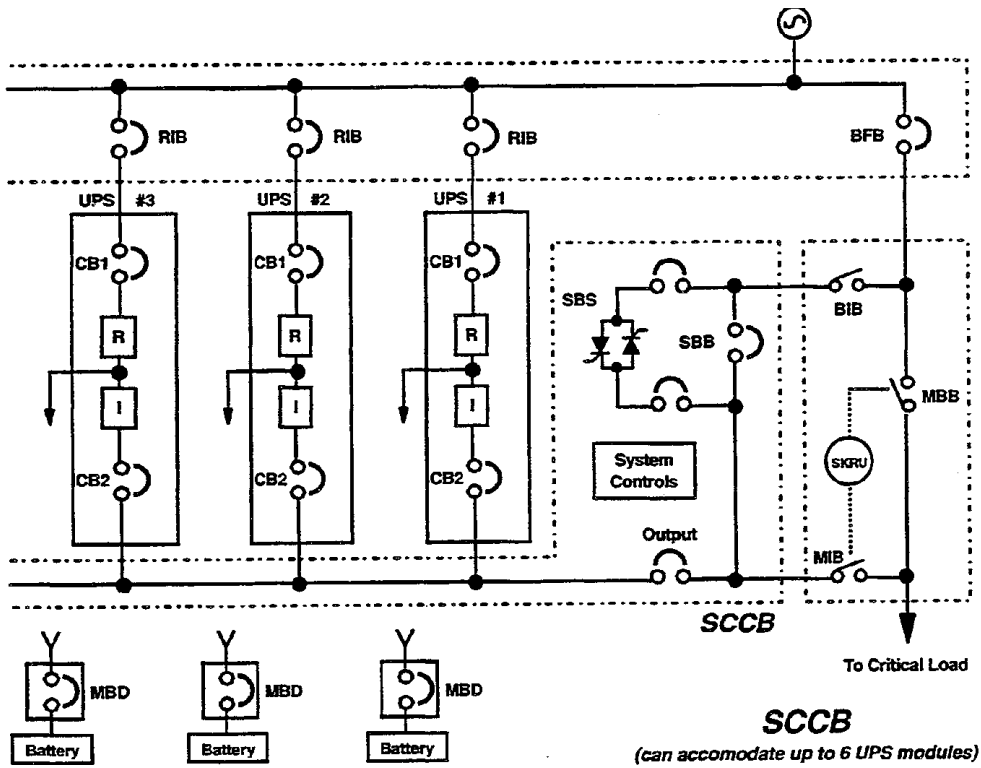
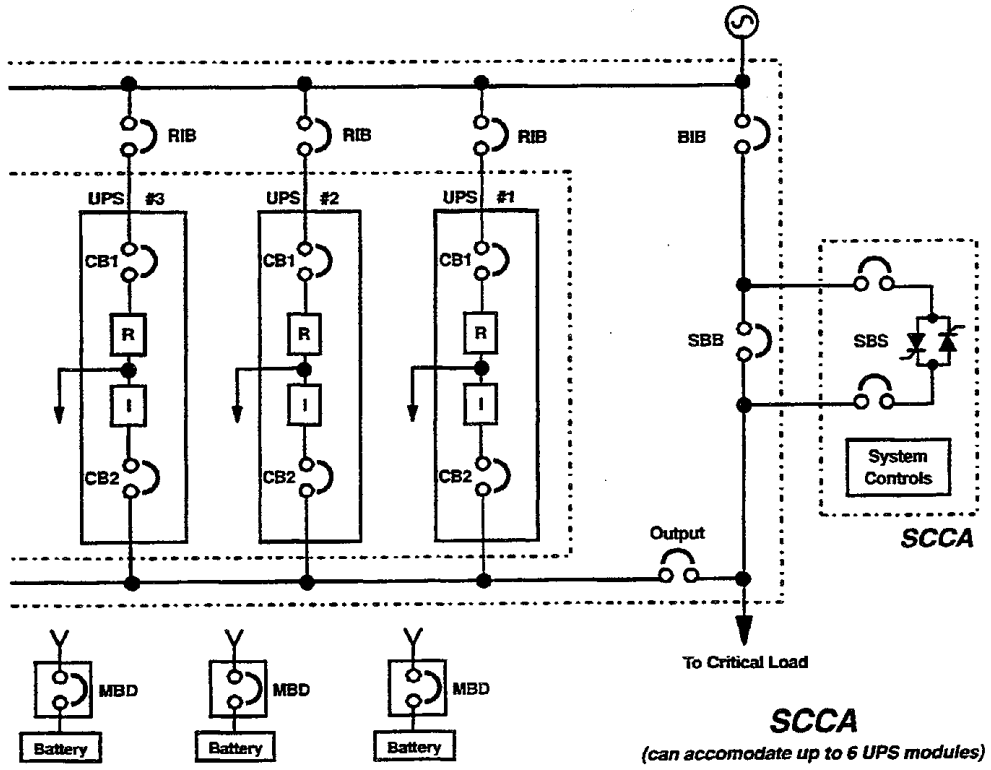
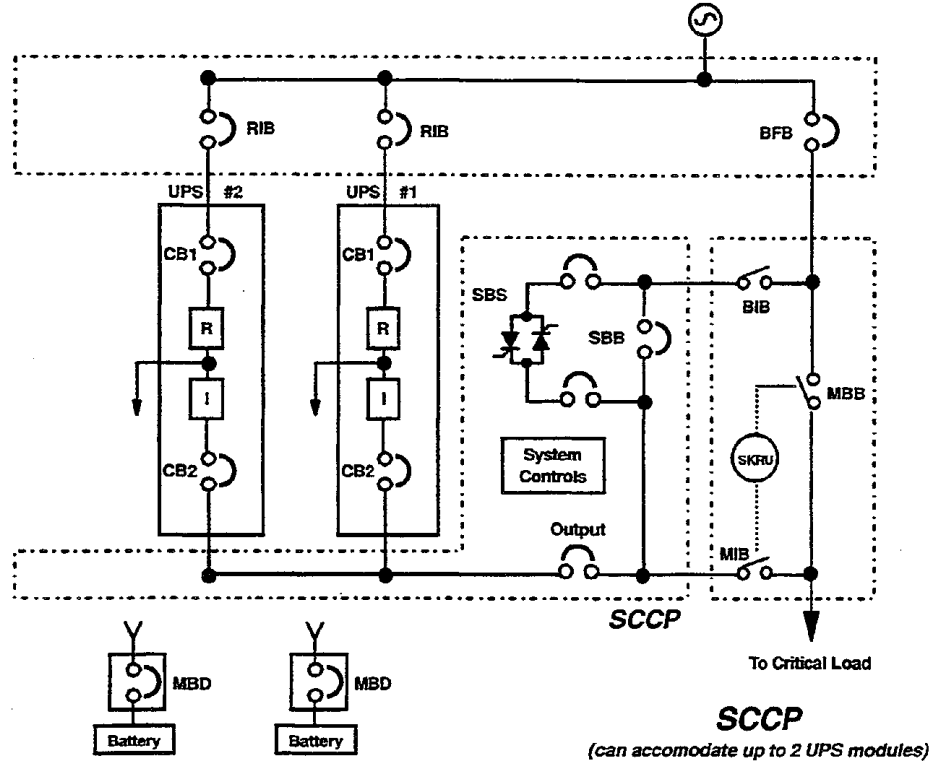
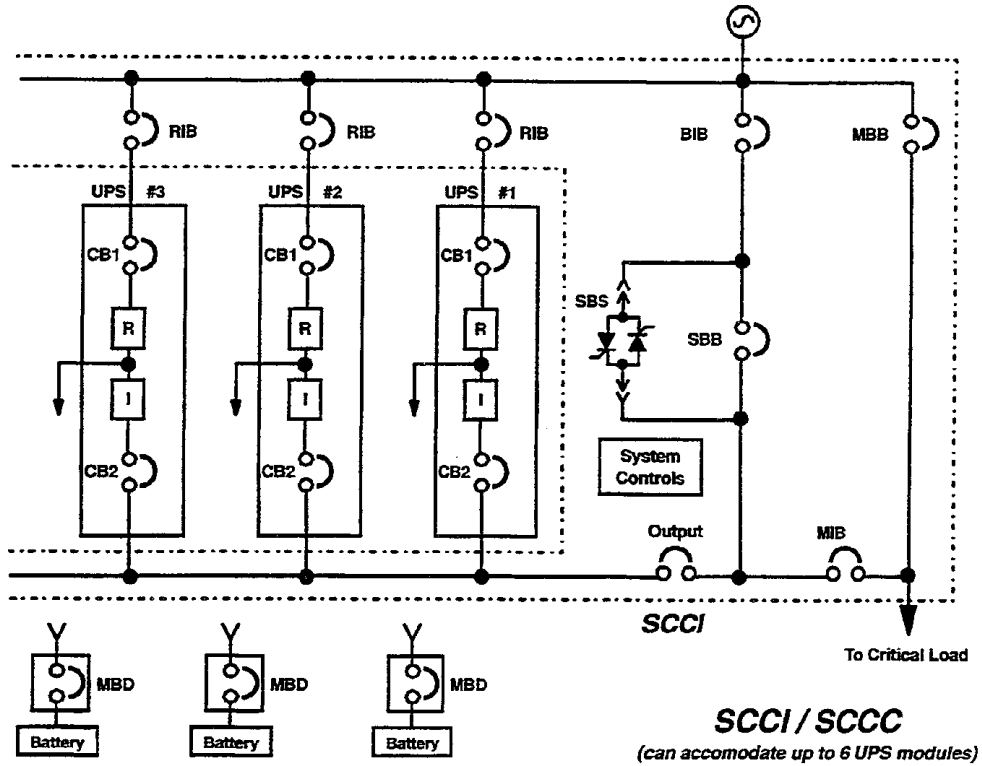


Figure 4 Typical Multi-Module Configurations (continued)



## 9.0 WIRING CONNECTIONS



### DANGER

**VERIFY THAT ALL INCOMING HIGH AND LOW VOLTAGE POWER CIRCUITS ARE DE-ENERGIZED AND LOCKED OUT BEFORE INSTALLING CABLES OR MAKING ELECTRICAL CONNECTIONS.**

**ALL POWER CONNECTIONS MUST BE COMPLETED BY A LICENSED ELECTRICIAN EXPERIENCED IN WIRING UPS EQUIPMENT, AND IN ACCORDANCE WITH ALL APPLICABLE NATIONAL AND LOCAL ELECTRICAL CODES.**

**IMPROPER WIRING MAY CAUSE DAMAGE TO THE UPS OR INJURY TO PERSONNEL.**



### CAUTION

**All shielded cables, non-shielded cables, non-shielded control wires, non-shielded battery breaker control wires, and non-shielded remote control wires must be housed in individual, separate, steel conduits. Placing multiple cables in the same conduit with other control or power wiring may cause system failure.**

Refer to the drawings in this manual and any other drawings provided by Liebert for this installation. Make all of the following connections:

1. AC power cables from input power source circuit breaker (RIB) to UPS Module Input. Observe phase rotation.
2. AC power cables from bypass power source circuit breaker (BIB) to UPS system bypass input at System Control Cabinet (SCC). Observe phase rotation.



### CAUTION

**If there are line-to-neutral loads connected to the UPS output, the bypass input source must be wye connected and have three phases plus neutral plus ground. If the specified input is not available, an isolation transformer is required.**

3. AC power cables from UPS Module Outputs to SCC or to switchgear for critical load bus. Observe phase rotation.



### NOTE

*Make sure all required wiring between each UPS module and the optional cabinet(s) is completed. Observe phase rotation.*

Abbreviations for Circuit Breakers	
BFB	Bypass Feeder Breaker
BIB	Bypass Input Breaker
CB1	Module Input Breaker
CB2	Module Output Breaker
MBB	Maintenance Bypass Breaker
MBD	Module Battery Disconnect
MBFB	Maintenance Bypass Feeder Breaker
MIB	Maintenance Isolation Breaker
RIB	Rectifier Input Breaker
SBB	System Bypass Breaker
SBS	Static Bypass Switch



- 
- Each UPS Module Output Neutral to SCC or to switchgear for critical load bus.
  - The UPS System Output Neutral is connected to one common point and solidly grounded per requirements of the National Electrical Code. The ground connection inside the UPS SCC cabinet may be required by the power wiring configuration at your site.

**CAUTION**

**UPS bypass and system output neutral must be connected to only one common point in the UPS system. This neutral line must be grounded at the source.**

- For Battery Cabinets:  
DC power cables (and ground) from Battery Cabinet to UPS Module, and between Battery Cabinets. Observe polarity.

**NOTE**

*DC power and battery circuit breaker control cables are provided with the matching Battery Cabinet.*

**DANGER**

**DO NOT MAKE ANY CONNECTIONS BETWEEN BATTERY TIERS IN THE BATTERY CABINET. THESE CONNECTIONS WILL BE MADE BY THE LIEBERT CUSTOMER SERVICE REPRESENTATIVE DURING START-UP.**

- For remote battery:  
DC power cables (and ground) from battery to Module Battery Disconnect, and then to UPS Module DC bus. Observe polarity.
- Module Battery Disconnect control wiring to UPS Module, and between Battery Cabinets.
- Control wiring from System Control Cabinet (SCC) to UPS modules. Wiring must be run in individual separate steel conduit.
- Power and control connections required for the Maintenance Bypass.
- Power connections from SCC to critical load bus. Observe phase rotation.
- Control wiring to Remote Monitor Panel, if used. Selected alarm messages are also available for customer use through a set of contacts on a separate terminal board. Wiring must be run in individual separate steel conduit.
- Emergency Power Off control wiring (to SCC) must be run in separate steel conduit.
- Communications wiring (to SCC) for terminals, site monitoring or for modem must be run in separate steel conduit.
- Any additional special wiring required at your site.

## 10.0 WIRING INSPECTION

1. Verify all power connections are tight.
2. Verify all control wire terminations are tight.
3. Verify all power wires and connections have proper spacing between exposed surfaces, phase-to-phase and phase-to-ground.
4. Verify that all control wires are run in individual, separate, steel conduit.

**Table 1 Power Wiring Terminals - Factory Supplied**

Connection Type					
UPS Module Rating kVA	AC Input	Battery	AC Output	Neutral	Ground
300-450 kVA	Bus bars for connecting hardware (3/8" on 1-3/4" centers) are provided for all power wiring terminations. A field-supplied lug is required.				Stud 5/16" - 18

Use 75°C copper wire. Select wire size based on the ampacities in **Table 310-16** (see **Table 3** of this manual) and associated notes of the National Electrical Code (NFPA 70).

Use commercially available solderless lugs for the wire size required for your application. Connect wire to the lug using tool and procedure specified by the lug manufacturer.

**Table 2 Torque Specifications**

Nut and Bolt Combinations				
Bolt Shaft Size	Grade 2 Standard		Electrical Connections with Belleville Washers	
	Lb-in	N-m	Lb-in	N-m
1/4	53	6.0	46	5.2
5/16	107	12	60	6.8
3/8	192	22	95	11
1/2	428	48	256	29

Circuit Breakers With Compression Lugs (For Power Wiring)		
Current Rating	Lb-in	N-m
400 - 1200 Amps	300	34

Terminal Block Compression Lugs (For Control Wiring)		
AWG Wire Size or Range	Lb-in	N-m
#22 - #14	3.5 to 5.3	0.4 to 0.6

Use the values in this table unless the equipment is labeled with a different torque value.

**Table 3 Table 310-16**

**Allowable Ampacities of Insulated Conductors Rated 0-2000 Volts, 60° to 90°C (140° to 194°F)<sup>1</sup>**

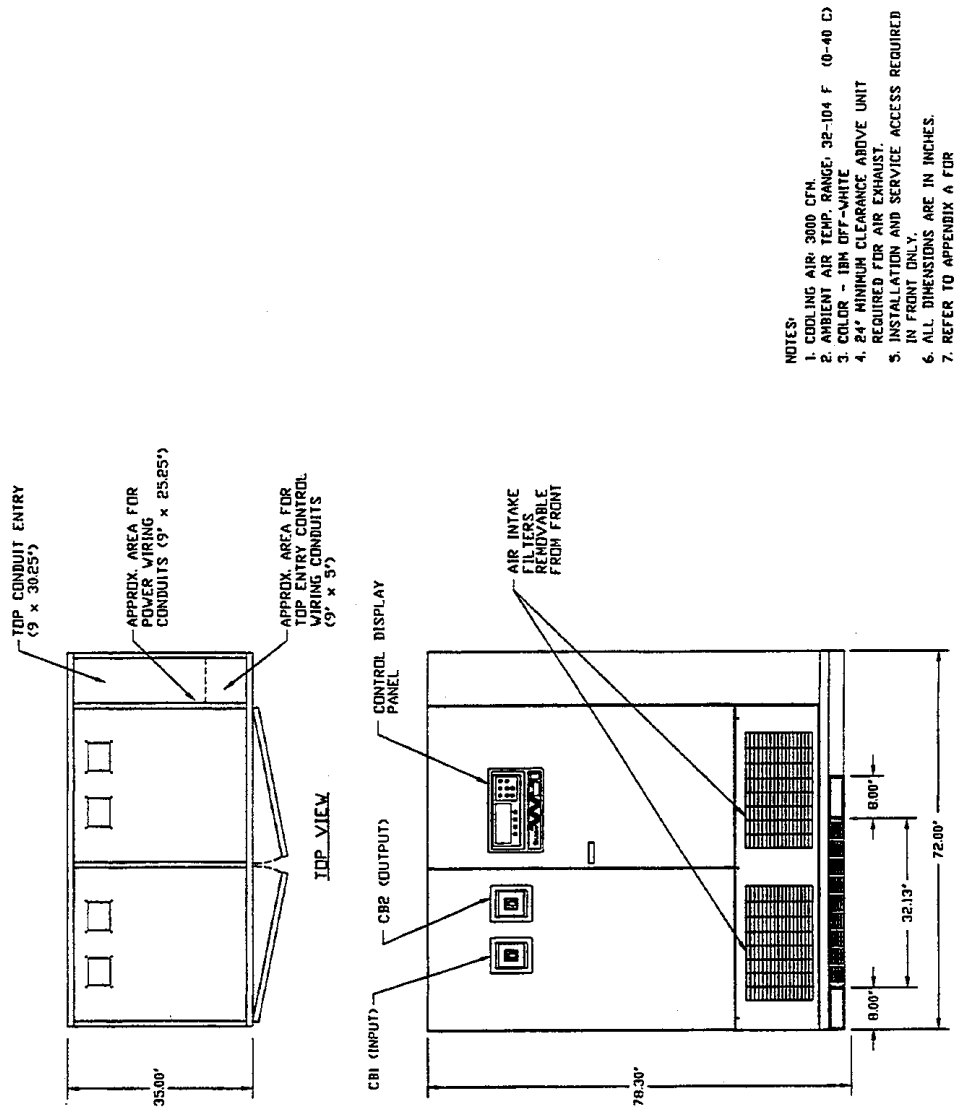
Not More than Three Conductors in Raceway or Cable or Earth (Directly Buried), based on Ambient Temperature of 30° (86°F)

Size	Temperature Rating of Conductor. See Table 310-13.						Size
	60°C (140°F)	75°C (167°F)	90°C (194°F)	60°C (140°F)	75°C (167°F)	90°C (194°F)	
	Types TW† UF†	Types FEPW†, RH,RHW†, THHW†, THW†, THWN†, XHHW†, USE†, ZW†	Types TBS, SA, SIS,FEP†, FEPB†,MI, RHH†, RHW-2 THHN†,THHW†, THW-2,THWN-2, USE-2, XHH, XHHW† XHHW-2,ZW-2	Types TW† UF†	Types RH†, RHW†, THHW†, THW†, THWN†, XHHW†, USE†	Types TBS, SA,SIS, THHN†, THHW†, THW-2, THWN-2, RHH†, RHW-2, USE-2, XHH, XHHW†, XHHW-2, ZW-2	
Copper			Aluminum or Copper-Clad Aluminum				
18	.....	.....	14	.....	.....	.....	.....
16	.....	.....	18	.....	.....	.....	.....
14	20†	20†	25†	.....	.....	.....	.....
12	25†	25†	30†	20†	20†	25†	12
10	30	35†	40†	25	30†	35†	10
8	40	50	55	30	40	45	8
6	55	65	75	40	50	60	6
4	70	85	95	55	65	75	4
3	85	100	110	65	75	85	3
2	95	115	130	75	90	100	2
1	110	130	150	85	100	115	1
1/0	125	150	170	100	120	135	1/0
2/0	145	175	195	115	135	150	2/0
3/0	165	200	225	130	155	175	3/0
4/0	195	230	260	150	180	205	4/0
250	215	255	290	170	205	230	250
300	240	285	320	190	230	255	300
350	260	310	350	210	250	280	350
400	280	335	380	225	270	305	400
500	320	380	430	260	310	350	500
600	355	420	475	285	340	385	600
700	385	460	520	310	375	420	700
750	400	475	535	320	385	435	750
800	410	490	555	330	395	450	800
900	435	520	585	355	425	480	900
1000	455	545	615	375	445	500	1000
1250	495	590	665	405	485	545	1250
1500	520	625	705	435	520	585	1500
1750	545	650	735	455	545	615	1750
2000	560	665	750	470	560	630	2000
Correction Factors							
Ambient Temp °C	For ambient temperatures other than 30°C (86°F), multiply the allowable ampacities shown above by the appropriate factor shown below.						Ambient Temp °F
21-25	1.08	1.05	1.04	1.08	1.05	1.04	70-77
26-30	1.00	1.00	1.00	1.00	1.00	1.00	78-86
31-35	.91	.94	.96	.91	.94	.96	87-95
36-40	.82	.88	.91	.82	.88	.91	96-104
41-45	.71	.82	.87	.71	.82	.87	105-113
46-50	.58	.75	.82	.58	.75	.82	114-122
51-55	.41	.67	.76	.41	.67	.76	123-131
56-60	.....	.58	.71	.....	.58	.71	132-140
61-70	.....	.33	.58	.....	.33	.58	141-158
71-80	.....	.....	.41	.....	.....	.41	159-176

† Unless otherwise specifically permitted elsewhere in this Code, the overcurrent protection for conductor types marked with an obelisk (†) shall not exceed 15 amperes for No. 14, 20 amperes for No. 12, and 30 amperes for No. 10 copper; or 15 amperes for No. 12 and 25 amperes for No. 10 aluminum and copper-clad aluminum after any correction factors for ambient temperature and number of conductors have been applied.


<sup>1</sup> Reprinted with permission from NFPA 70-1993, the National Electrical Code®, Copyright 1996, National Fire Protection Association, Quincy, MA 02269. This reprinted material is not the complete and official position of the National Fire Protection Association, on the referenced subject which is represented only by the standard in its entirety.

Figure 5 Outline Drawing, 300 to 450 kVA Multi-Module UPS, 480 or 600 VAC Input

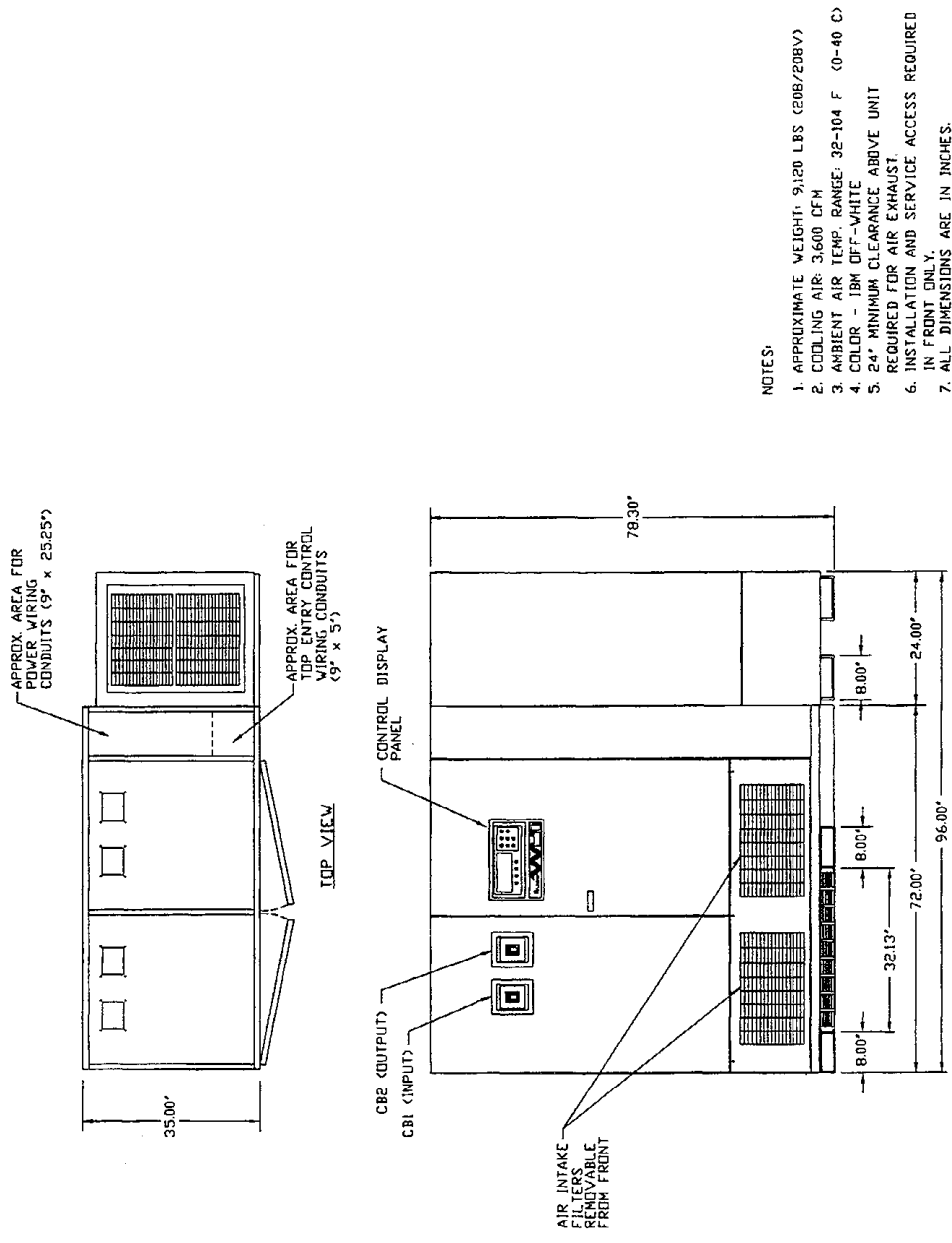


- NOTES:
1. COOLING AIR: 3000 CFM.
  2. AMBIENT AIR TEMP. RANGE: 32-104 F (0-40 C)
  3. COLOR - IBM OFF-WHITE
  4. 24" MINIMUM CLEARANCE ABOVE UNIT REQUIRED FOR AIR EXHAUST.
  5. INSTALLATION AND SERVICE ACCESS REQUIRED IN FRONT ONLY.
  6. ALL DIMENSIONS ARE IN INCHES.
  7. REFER TO APPENDIX A FOR WEIGHTS AND HEAT DISSIPATION.

FRONT VIEW

DRAWN BY T. NGUYEN		SHEET NO 1 OF 1		DWG. NO. 88-797601-10		DATE 04/10/96	
CHK BY J. CAMPBELL		ECN NO		REV. NO. 1		ORDER NO.	
DES' APVL		REF. DWG. IN70110		TITLE OUTLINE DRAWING 300 - 450 KVA MULTI - MODULE UPS SERIES 600T			
 9650 LERMINO RD. IRVINE, CALIFORNIA 92718							

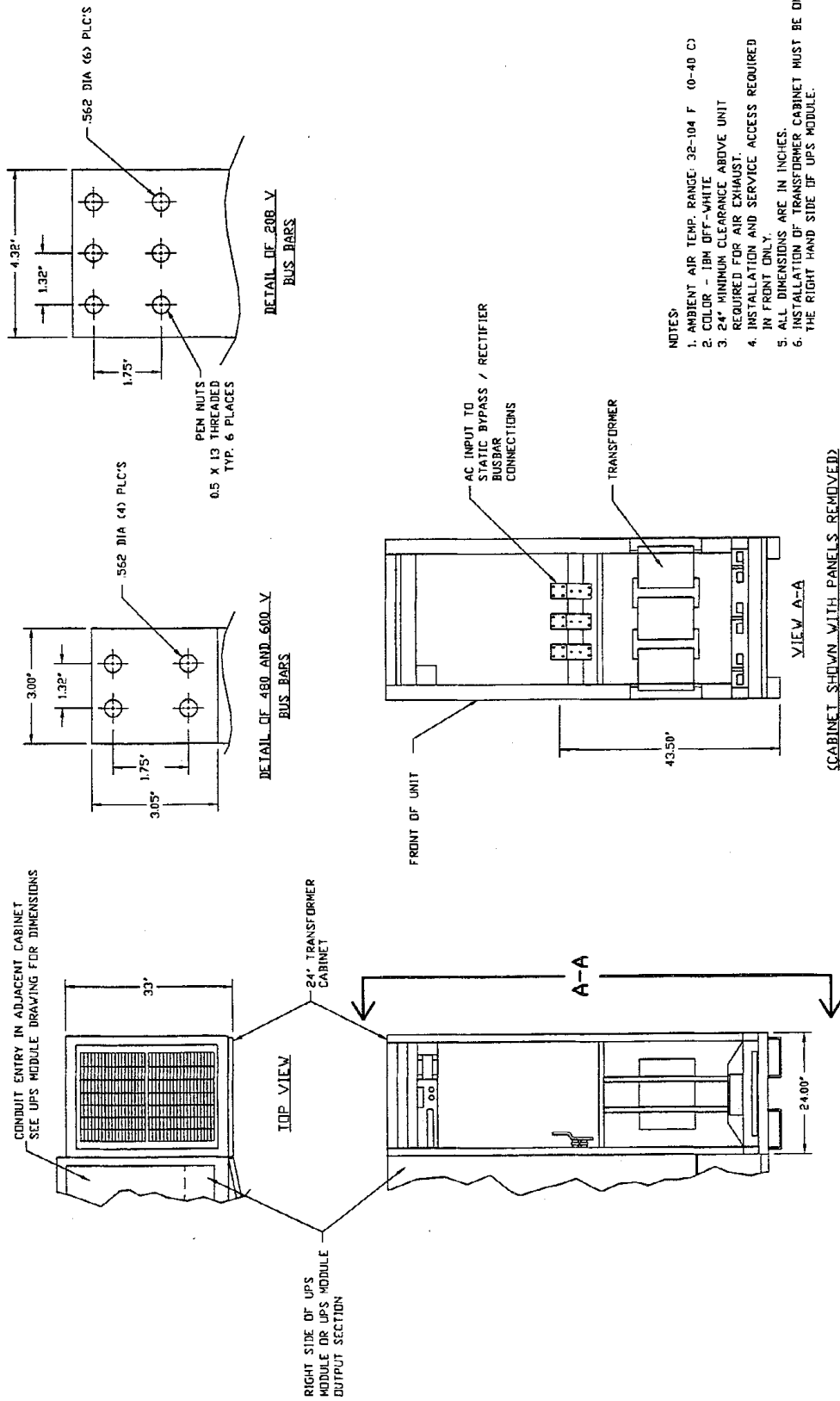
**Figure 6 Outline Drawing, 375 kVA with 208 VAC Input, or All Other 300 to 450 kVA UPS With Optional Transformer Cabinet**



- NOTES:**
1. APPROXIMATE WEIGHT: 9,120 LBS (208/208V)
  2. COOLING AIR: 3,600 CFM
  3. AMBIENT AIR TEMP. RANGE: 32-104 F (0-40 C)
  4. COLOR - IBM OFF-WHITE
  5. 24" MINIMUM CLEARANCE ABOVE UNIT REQUIRED FOR AIR EXHAUST.
  6. INSTALLATION AND SERVICE ACCESS REQUIRED IN FRONT ONLY.
  7. ALL DIMENSIONS ARE IN INCHES.

DRAWN BY T. NGUYEN		SHEET NO 1 OF 1		TITLE	
CHK BY J. CAMPBELL		ECN NO		OUTLINE DRAWING	
DES. APVL		REF. DWG. IN74681		375 kVA MULTI-MODULE UPS	
				208 V INPUT - 208 / 120 V OUTPUT	
				SERIES 6001	
				DWG. NO.	DATE
				88-797646-81	06/05/96
				REV. NO.	ORDER NO.
				2	
				 9650 JEROME RD. IRVINE, CALIFORNIA 92718	

Figure 7 Outline Drawing, Optional Transformer Cabinet




- NOTES:
1. AMBIENT AIR TEMP. RANGE: 32-104 F (0-40 C)
  2. COLOR - IBM OFF-WHITE
  3. 24" MINIMUM CLEARANCE ABOVE UNIT REQUIRED FOR AIR EXHAUST.
  4. INSTALLATION AND SERVICE ACCESS REQUIRED IN FRONT ONLY.
  5. ALL DIMENSIONS ARE IN INCHES.
  6. INSTALLATION OF TRANSFORMER CABINET MUST BE ON THE RIGHT HAND SIDE OF UPS MODULE.

FRONT VIEW

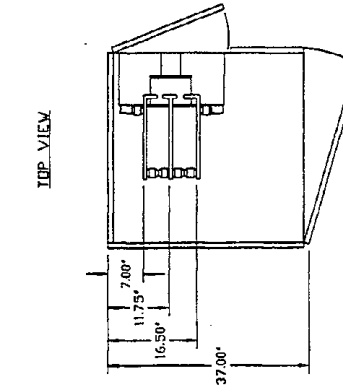
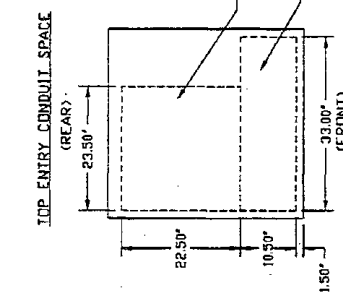
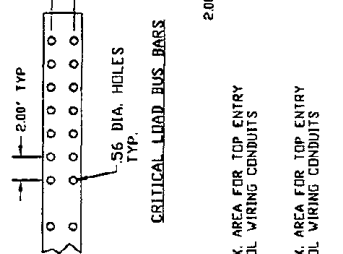
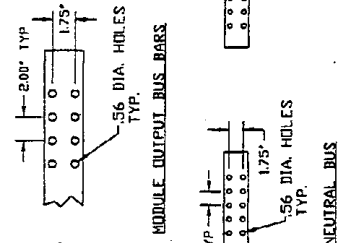
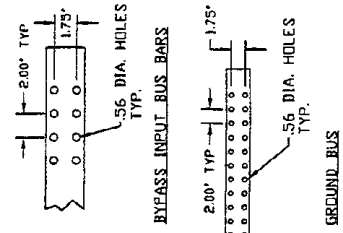
VIEW A-A

SCABINET SHOWN WITH PANELS REMOVED

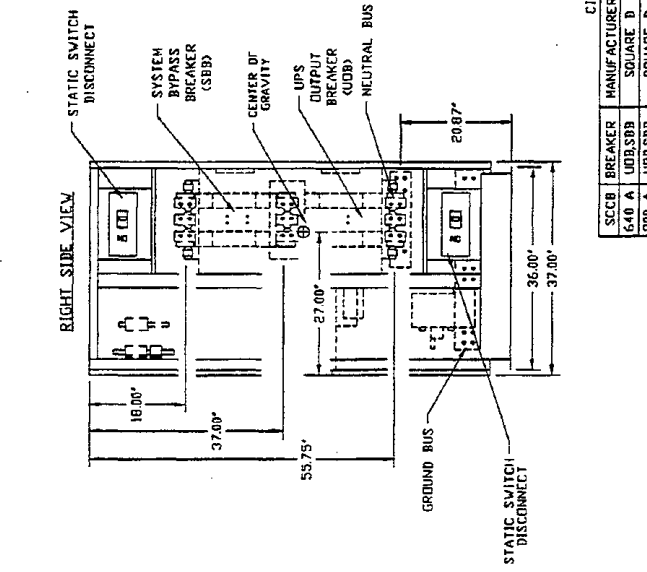
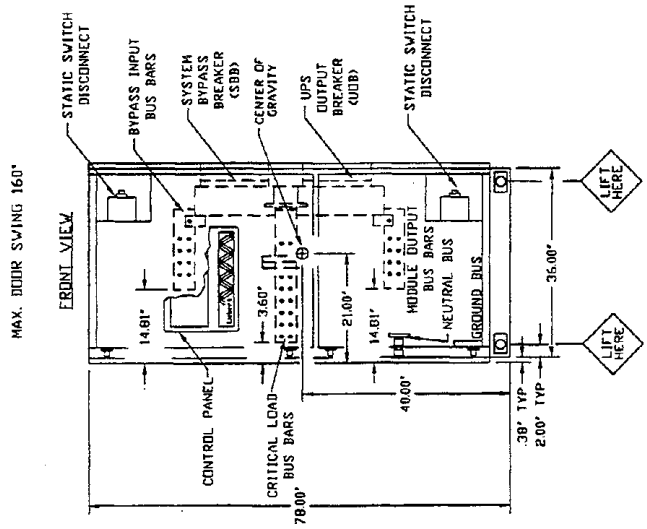
DRAWN BY T HECKMAN	SHEET NO 1 OF 1	TITLE	
		OUTLINE DRAWING 300 - 450 KVA 24" TRANSFORMER CABINET (OPTIONAL) SERIES 600T	
CHK BY J CAMPBELL	ECN NO	DWG. NO. 88-797611-05	DATE 04/18/96
DES APVL	REF. DWG. IN7105	REV. NO. 1	ORDER NO.
 9650 JERONIMO RD. IRVINE, CALIFORNIA 92718			

FILE NAME: INT105.DWG

Figure 8 Outline Drawing, System Control Cabinet (SCCB) 640 to 800 Amps



MAX. DOOR SWING 160°



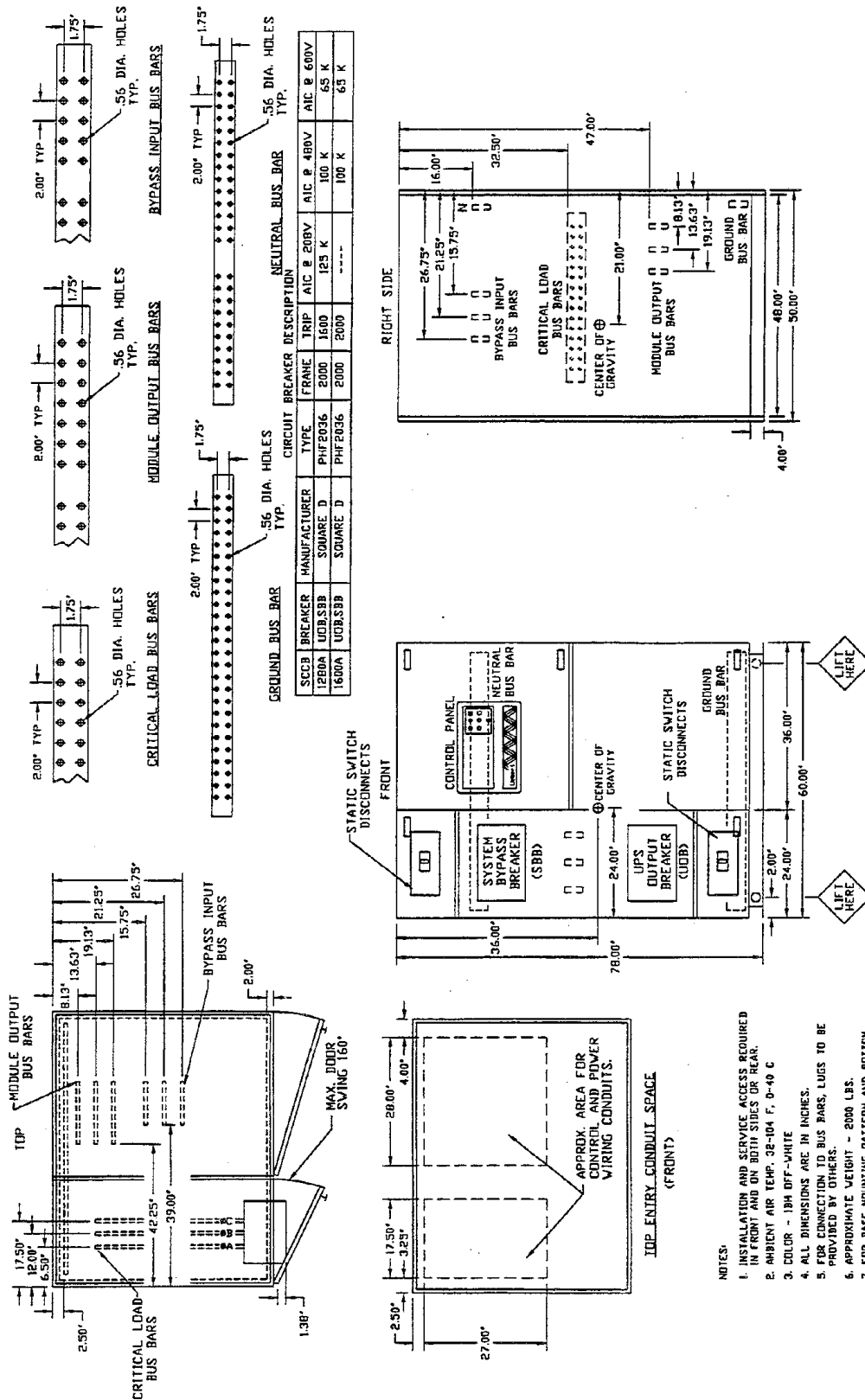
- NOTES:
1. APPROX. WEIGHT - 1100 LBS.
  2. AMBIENT AIR TEMP. RANGE: 32-104 F
  3. COLOR - 1BH OFF-WHITE
  4. ALL DIMENSIONS ARE IN INCHES.
  5. INSTALLATION AND SERVICE ACCESS REQUIRED IN FRONT, REAR, AND RIGHT SIDE.
  6. CABLE ENTRY REFER TO DRAWING 88-797613-10.

SCCB BREAKER	MANUFACTURER	TYPE	FRAME	TRIP	AIC @ 480V	AIC @ 600V
640 A	UDS/SBB	MHL36000	1000	800	65 K	25 K
800 A	UDS/SBB	PHC361000	1000	1000	65 K	25 K

DRAWN BY B FISH		SHEET NO 1 OF 1	
CHK BY J CAMPBELL		ECN NO	
DES APVL		REF. DWG. IN71423	
TITLE OUTLINE DRAWING SYSTEM CONTROL CABINET (SCCB) 640 - 800 AMP SERIES 600T			
DWG. NO. 88-797614-23		DATE 09/07/95	
REV. NO. 2		ORDER NO.	



Figure 9 Outline Drawing, System Control Cabinet (SCCB) 1280 to 1600 Amps



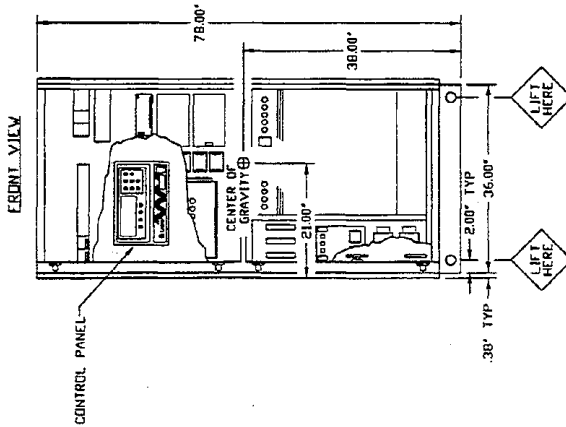
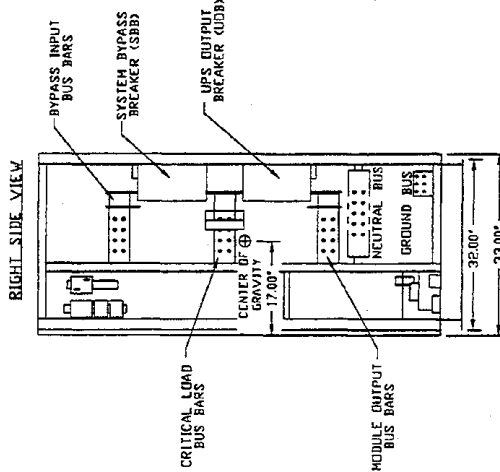
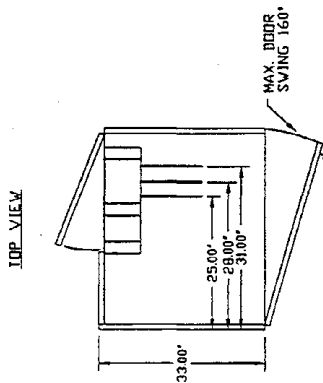
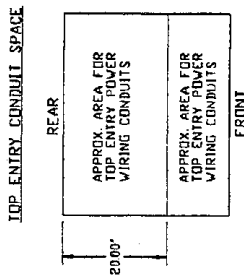
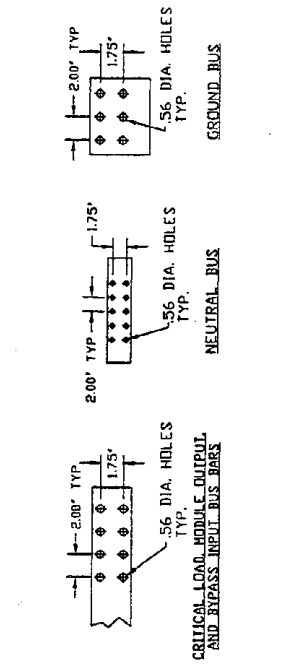
- NOTES:
1. INSTALLATION AND SERVICE ACCESS REQUIRED IN FRONT AND ON BOTH SIDES OR REAR.
  2. AMBIENT AIR TEMP. 32-104 F, 0-40 C
  3. COLOR - 194 OFF-WHITE
  4. ALL DIMENSIONS ARE IN INCHES.
  5. FOR CONNECTION TO BUS BARS, LUGS TO BE PROVIDED BY OTHERS.
  6. APPROXIMATE WEIGHT - 2000 LBS.
  7. FOR BASE MOUNTING PATTERN AND BOTTOM CABLE ENTRY REFER TO DRAWING 88-797613-10.

DRAWN BY B FISH		SHEET NO 1 OF 1		TITLE OUTLINE DRAWING SYSTEM CONTROL CABINET (SCCB) 1280 - 1600 AMP SERIES 600T	
CHK BY J CAMPBELL		ECN NO		DWG. NO. 88-797614-24	
DES APVL		REF. DWG. IN71424		DATE 09/07/95	
				ORDER NO.	
				2	

9650 JERONIMO RD.  
 IRVINE, CALIFORNIA 92718  
 FILE NAME: INT4824.DWG



Figure 10 Outline Drawing, System Control Cabinet (SCCP) 200 to 480 Amps



NOTES:

1. APPROXIMATE WEIGHT - 1000 LBS.
2. AMBIENT AIR TEMP. RANGE: 32-104 F
3. COLOR - 1BA DIF-WHITE
4. ALL DIMENSIONS ARE IN INCHES.
5. INSTALLATION AND SERVICE ACCESS REQUIRED
6. IN FRONT, REAR, AND RIGHT OR LEFT SIDE.
7. FOR BASE MOUNTING PATTERN AND BOTTOM CABLE ENTRY REFER TO DRAWING 88-797613-12.

CIRCUIT BREAKER DESCRIPTION

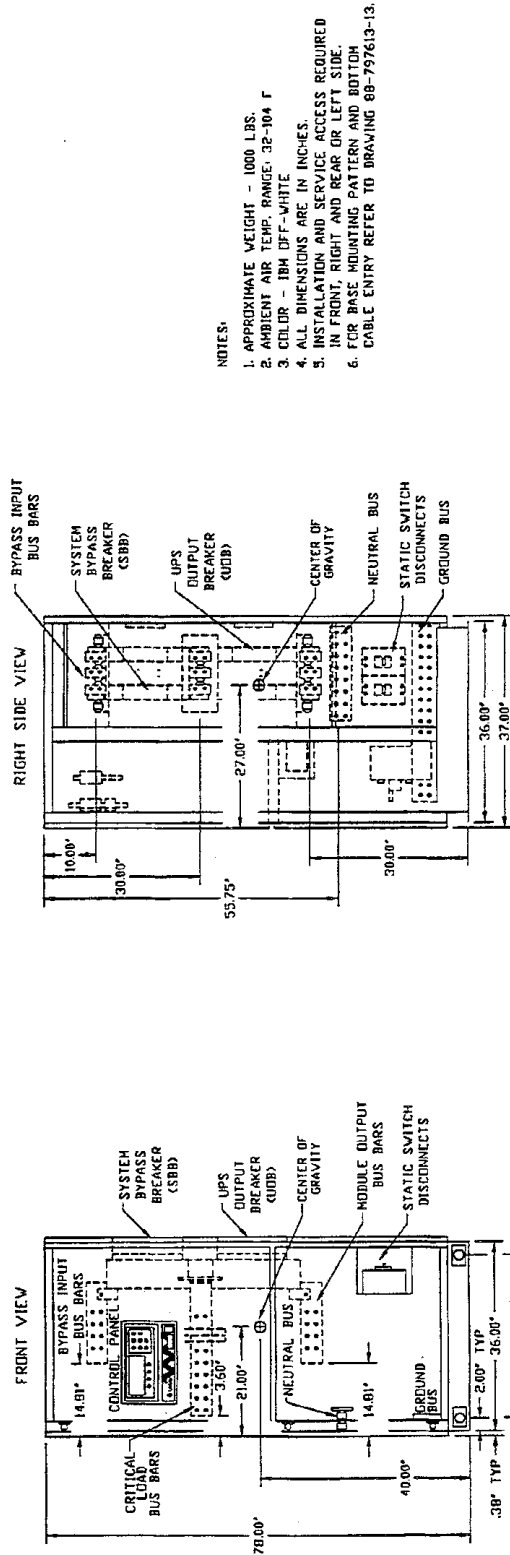
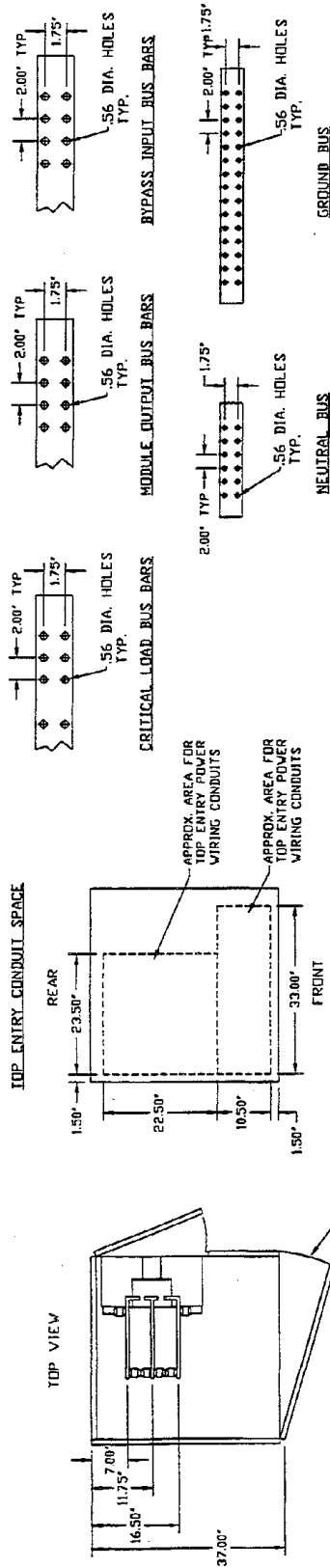
SCCP	BREAKER	MANUFACTURER	TYPE	TRIP	AIC @ 200V	AIC @ 480V	AIC @ 600V
200 A	UDB,SBB	SQUARE D	LHL36250	400	250	35 K	25 K
260 A	UDB,SBB	SQUARE D	LHL36350	400	350	35 K	25 K
360 A	UDB,SBB	SQUARE D	MHL36450	1000	450	65 K	25 K
480 A	UDB,SBB	SQUARE D	MHL36600	1000	600	65 K	25 K

DRAWN BY B. FISH		SHEET NO 1 OF 1	
CHK BY J. CAMPBELL		ECN NO	
DES' APVL		REF. DWG. IN71427	
TITLE SYSTEM CONTROL CABINET (SCCP) 200 - 480 AMP SERIES 600T			
DWG. NO. 88-797614-27		DATE 09/07/95	
REV. NO. 2		ORDER NO.	



FILE NAME: IN71427E.DWG

Figure 11 Outline Drawing, System Control Cabinet (SCCP) 560 to 960 Amps



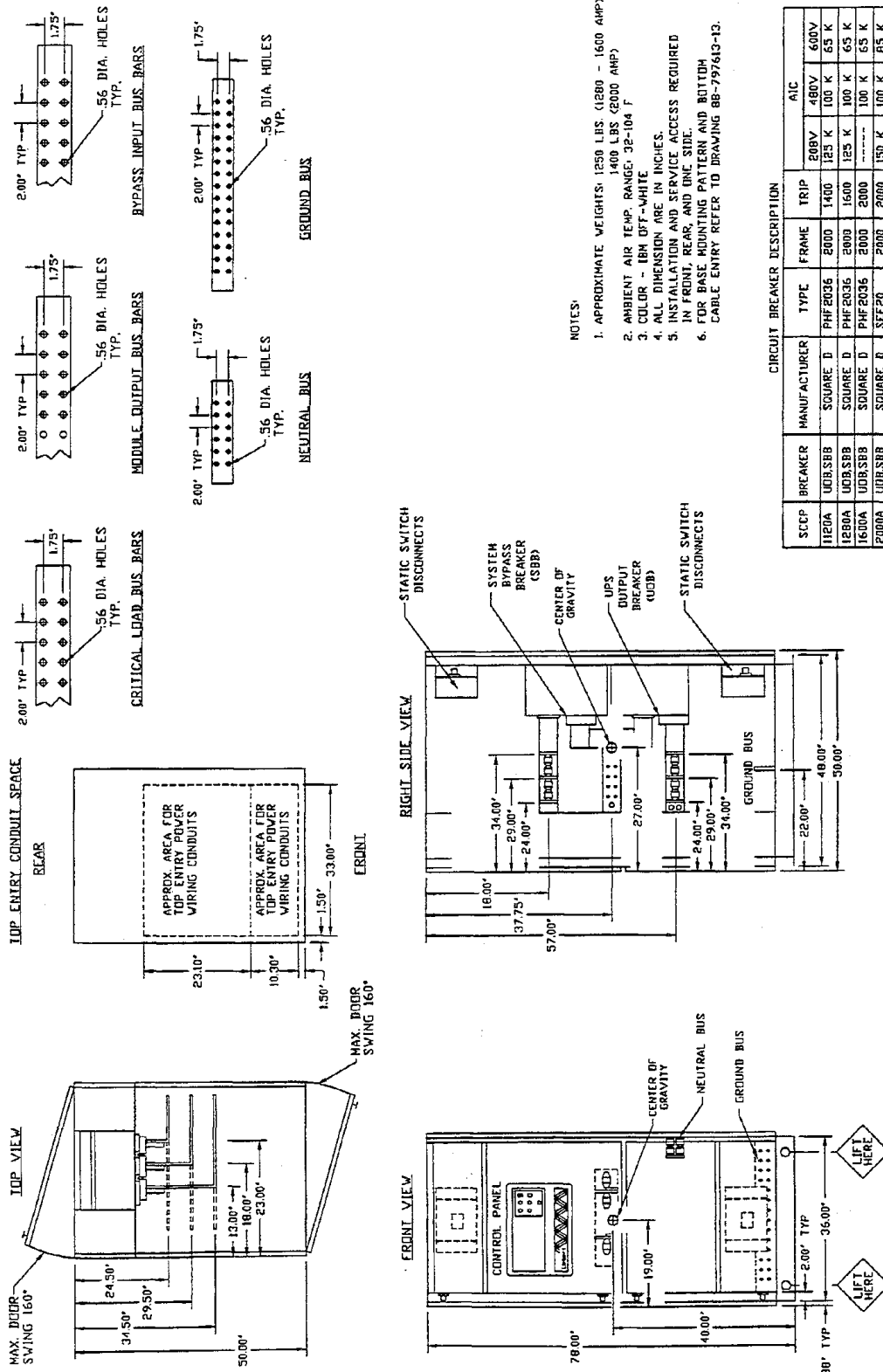
- NOTES:
1. APPROXIMATE WEIGHT - 1000 LBS.
  2. AMBIENT AIR TEMP. RANGE: 32-104 F
  3. COLOR - 1BA OFF-WHITE
  4. ALL DIMENSIONS ARE IN INCHES.
  5. INSTALLATION AND SERVICE ACCESS REQUIRED IN FRONT, RIGHT AND REAR OR LEFT SIDE.
  6. FOR BASE MOUNTING PATTERN AND BOTTOM CABLE ENTRY REFER TO DRAWING 88-797613-13.

CIRCUIT BREAKER DESCRIPTION	
SCCP BREAKER	MANUFACTURER
560 A UOB.SBB	SQUARE D
640 A UOB.SBB	SQUARE D
800 A UOB.SBB	SQUARE D
960 A UOB.SBB	SQUARE D

DRAWN BY B FISH		SHEET NO 1 OF 1	
CHK BY J CAMPBELL		E.C.N NO	
DES APVL IN71428		REF. DWG.	
TITLE OUTLINE DRAWING SYSTEM CONTROL CABINET (SCCP) 560 - 960 AMP SERIES 600T			
DWG. NO. 88-797614-28		DATE 09/07/95	
REV. NO. 2		ORDER NO.	



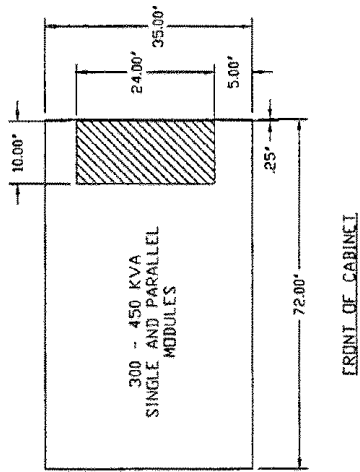
Figure 12 Outline Drawing, System Control Cabinet (SCCP) 1120 to 2000 Amps



DRAWN BY B FISH		SHEET NO 1 OF 1	
CHK BY J CAMPBELL		ECN NO	
DES APVL IN71429		REF. DWG.	
TITLE OUTLINE DRAWING SYSTEM CONTROL CABINET (SCCP) 1120 - 2000 AMP SERIES 600T			
DWG. NO. 88-797614-29		DATE 09/07/95	
REV. NO. 2		ORDER NO.	



Figure 13 Base Mounting Patterns, 300 to 450 kVA UPS Modules



- NOTES:
1. SHADED AREAS (REMOVABLE PLATES) INDICATE LOCATIONS FOR BOTTOM ENTRY OF CUSTOMER'S CABLES IF DESIRED.
  2. THE REMOVABLE PLATES SHOWN ARE LOCATED APPROXIMATELY 4.00 INCHES FROM THE CABINET BASE MOUNTING SURFACE (e.g. CONCRETE FLOOR).
  3. TOLERANCE ON ALL DIMENSIONS IS  $\pm 2S$ .
  4. ALL DIMENSIONS ARE IN INCHES.
  5. ALL PATTERNS ARE TOP VIEW ONLY.


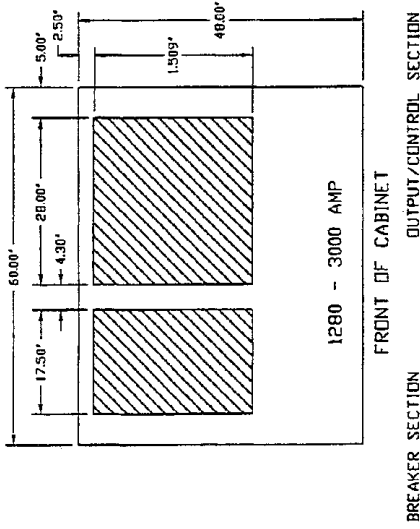
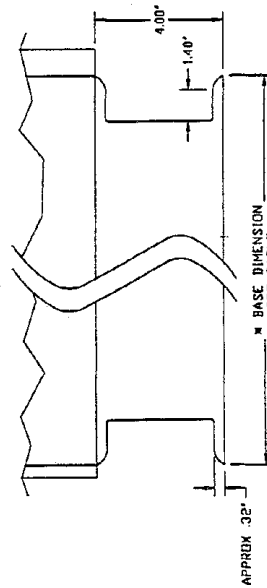
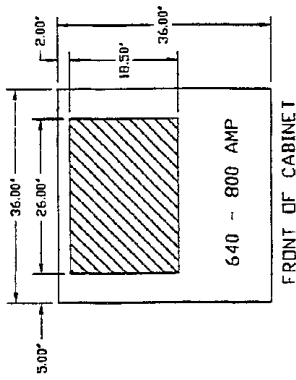
DRAWN BY T. HECKMAN		SHEET NO 1 OF 1	TITLE BASE MOUNTING PATTERNS 300 - 450 KVA MODULES SERIES 600T	
CHK BY J. CAMPBELL		ECN NO	DWG. NO. 88-797613-15	DATE 06/06/96
DES. APVL		REF. DWG. DM71315	REV. NO. 3	ORDER NO.
			 9650 MERCINO RD. IRVINE, CALIFORNIA 92718	

Figure 14 Base Mounting Patterns, System Control Cabinet (SCCB) 640 to 3000 Amps



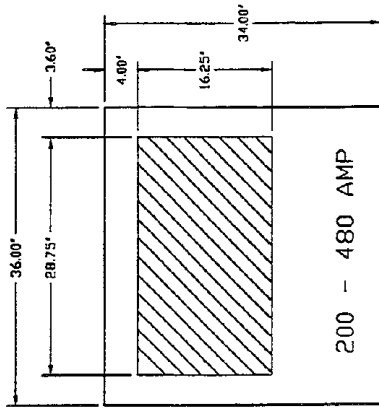
AMP	BASE DEPTH
640 THRU 800	36"
2000 THRU 3000	48"

- NOTES:
1. SHADED AREAS (REMOVABLE PLATES) INDICATE LOCATIONS FOR BOTTOM ENTRY OF CUSTOMER'S CABLES IF DESIRED.
  2. THE REMOVABLE PLATES SHOWN ARE LOCATED APPROXIMATELY 4 INCHES FROM THE CABINET BASE MOUNTING SURFACE (e.g. CONCRETE FLOOR).
  3. TOLERANCE ON ALL DIMENSIONS IS  $\pm .25$ "
  4. ALL DIMENSIONS ARE IN INCHES.

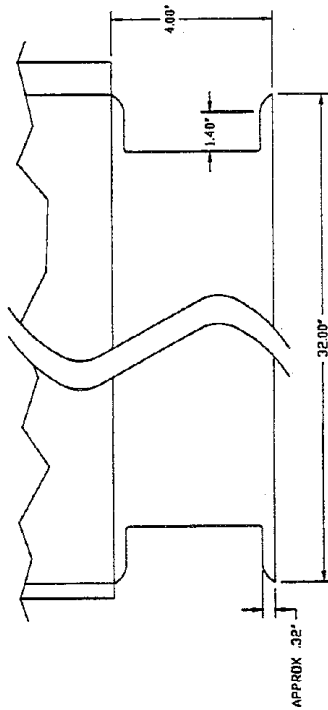


DRAWN BY B FISH		SHEET NO 1 OF 1		TITLE BASE MOUNTING PATTERNS SYSTEM CONTROL CABINETS (SCCB) 640 - 3000 AMP SERIES 600T	
CHK BY J CAMPBELL		ECN NO		DATE 09/07/95	
DES' APVL		REF. DWG. DM71310		REV. NO. 2	
				DWG. NO. 88-797613-10	
				ORDER NO.	
				FILE NAME: 8871312.DWG	
				 9650 JERONIMO RD. IRVINE, CALIFORNIA 92718	

Figure 15 Base Mounting Patterns, System Control Cabinet (SCCP) 200 to 480 Amps



FRONT OF CABINET



BASE CHANNEL DETAIL (FRONT & REAR)  
SIDE VIEW

NOTES:

1. SHADED AREAS (REMOVABLE PLATES) INDICATE LOCATIONS FOR BOTTOM ENTRY OF CUSTOMER'S CABLES IF DESIRED.
2. THE REMOVABLE PLATES SHOWN ARE LOCATED APPROXIMATELY 4 INCHES FROM THE CABINET BASE MOUNTING SURFACE (e.g. CONCRETE FLOOR).
3. TOLERANCE ON ALL DIMENSIONS IS  $\pm .25$ "
4. ALL DIMENSIONS ARE IN INCHES.


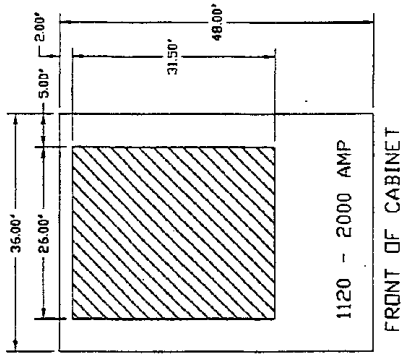
DRAWN BY B. FISH		SHEET NO 1 OF 1		TITLE BASE MOUNTING PATTERNS SYSTEM CONTROL CABINET (SCCP) 200 480 AMP SERIES 600T	
CHK BY J. CAMPBELL		ECN NO		DWG. NO. 88-797613-12	
DES. APVL		REF. DWG. DM71312		DATE 09/07/95	
				ORDER NO.	
				REV. NO. 2	
				FILE NAME: 09710122.DWG	
				 9650 JEROME RD. IRVINE, CALIFORNIA 92718	

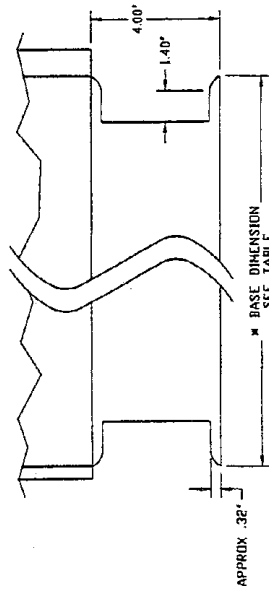
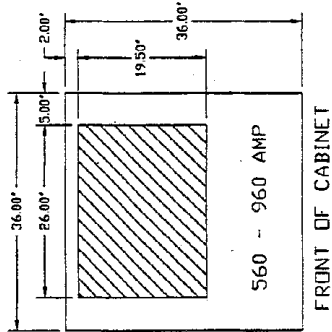
Figure 16 Base Mounting Patterns, System Control Cabinet (SCCP) 560 to 2000 Amps



AMP	BASE DEPTH
560 THRU 960	36"
1120 THRU 2000	48"

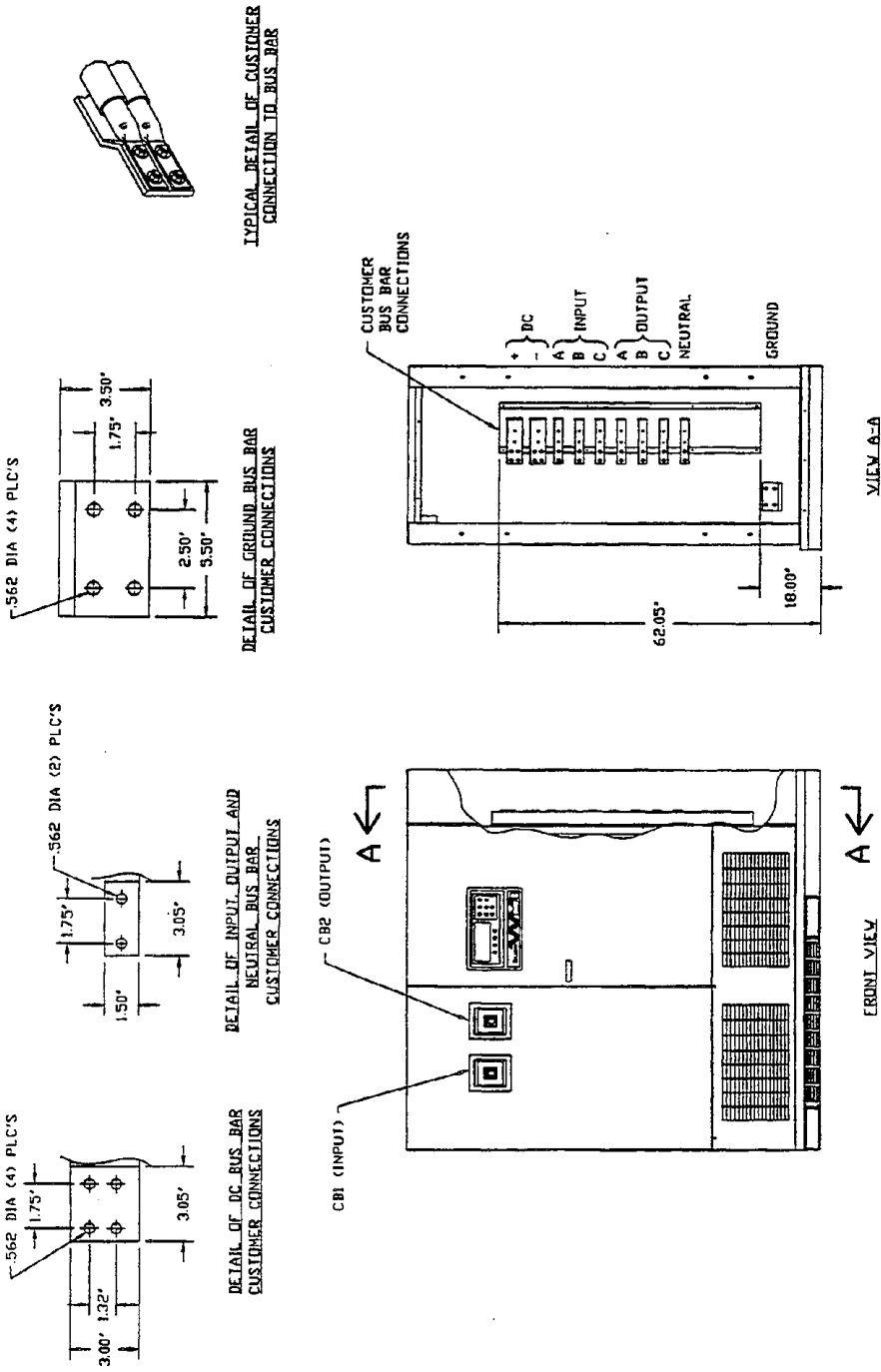
NOTES:

1. SHADED AREAS (REMOVABLE PLATES) INDICATE LOCATIONS FOR BOTTOM ENTRY OF CUSTOMER'S CABLES IF DESIRED.
2. THE REMOVABLE PLATES SHOWN ARE LOCATED APPROXIMATELY 4 INCHES FROM THE CABINET BASE MOUNTING SURFACE (e.g. CONCRETE FLOOR).
3. TOLERANCE ON ALL DIMENSIONS IS  $\pm .25$ .
4. ALL DIMENSIONS ARE IN INCHES.



DRAWN BY B FISH	SHEET NO 1 OF 1	TITLE BASE MOUNTING PATTERNS SYSTEM CONTROL CABINETS (SCCP) 560 - 2000 AMP SERIES 600T	
CHK BY J CAMPBELL	ECN NO	DWG. NO. 88-797613-13	DATE 09/07/95
DES. APVL	REF. DWG. DM71313	REV. NO. 2	ORDER NO.
		 IRVINE, CALIFORNIA 92718	

Figure 17 Bussing Details, Modules With 480 and 600 VAC Output

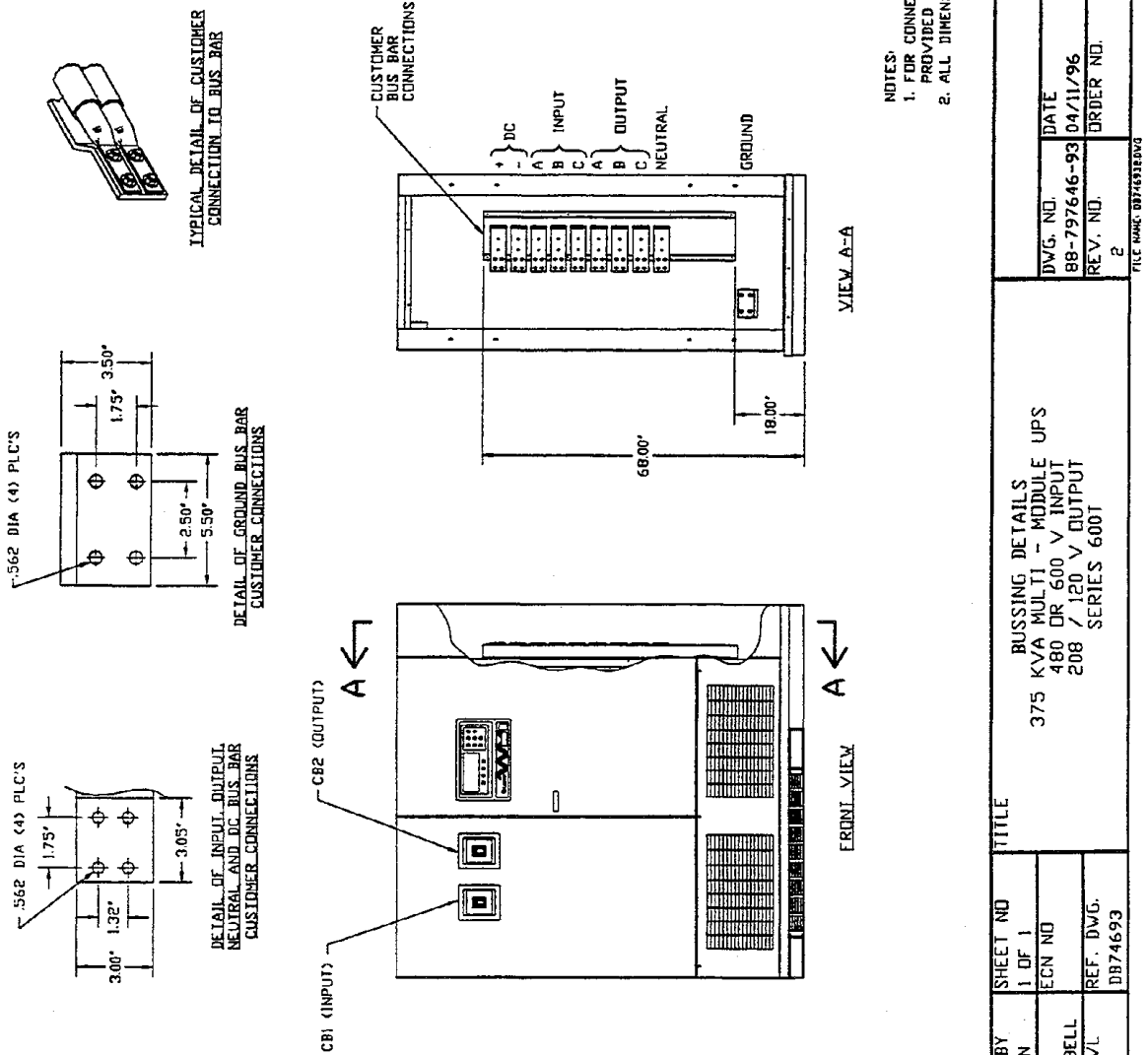


NOTES:  
 1. FOR CONNECTION TO BUS BARS LUGS TO BE PROVIDED BY OTHERS.  
 2. ALL DIMENSIONS ARE IN INCHES.

DRAWN BY T. NGUYEN		SHEET NO 1 OF 1		TITLE BUSSEING DETAILS	
CHK BY J. CAMPBELL		ECN NO		375 KVA MULTI - MODULE UPS	
DES APVL		REF. DWG. DB74694		480 V INPUT - 480 / 277 V OUTPUT	
				600 V INPUT - 600 / 346 V OUTPUT	
				SERIES 600T	
		DWG. NO. 88-797646-94		DATE 04/11/96	
		REV. NO. 2		ORDER NO.	
 9650 JERONIMO RD. IRVINE, CALIFORNIA 92718					

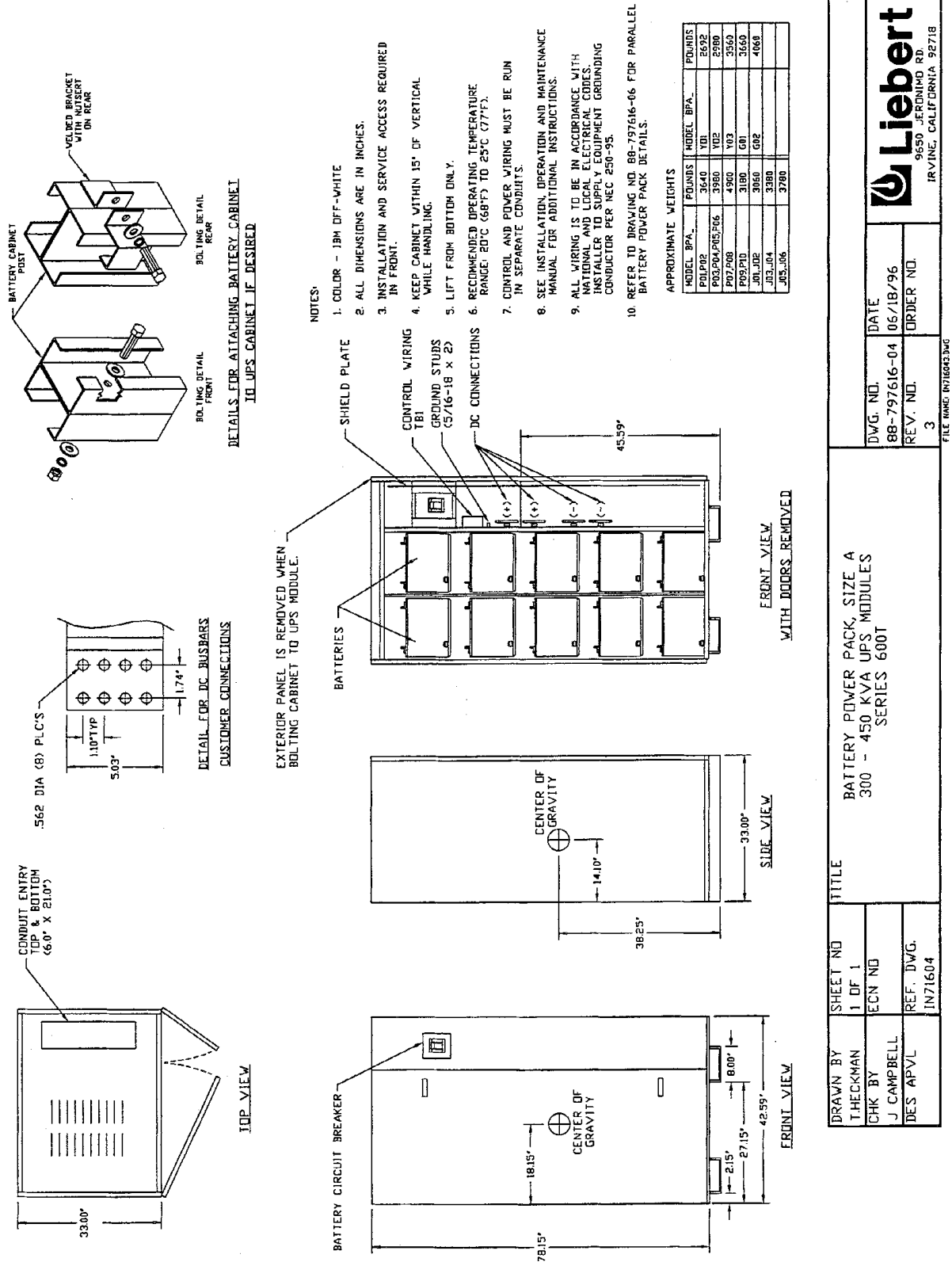


Figure 18 Bussing Details, Modules With 208 VAC Output



DRAWN BY T. NGUYEN		SHEET NO 1 OF 1		TITLE BUSSING DETAILS		DWG. NO. 88-797646-93		DATE 04/11/96	
CHK BY J. CAMPBELL		ECN NO		375 KVA MULTI - MODULE UPS		REV. NO. 2		ORDER NO.	
DES APVL		REF. DWG. DB74693		480 DR 600 V INPUT		FILE NAME DB74693.DWG		IRVINE, CALIFORNIA 92718	
				208 / 120 V OUTPUT				Liebert	
				SERIES 600T				9630 JERDINO RD.	

Figure 19 Outline Drawing, Battery Cabinet, Size A

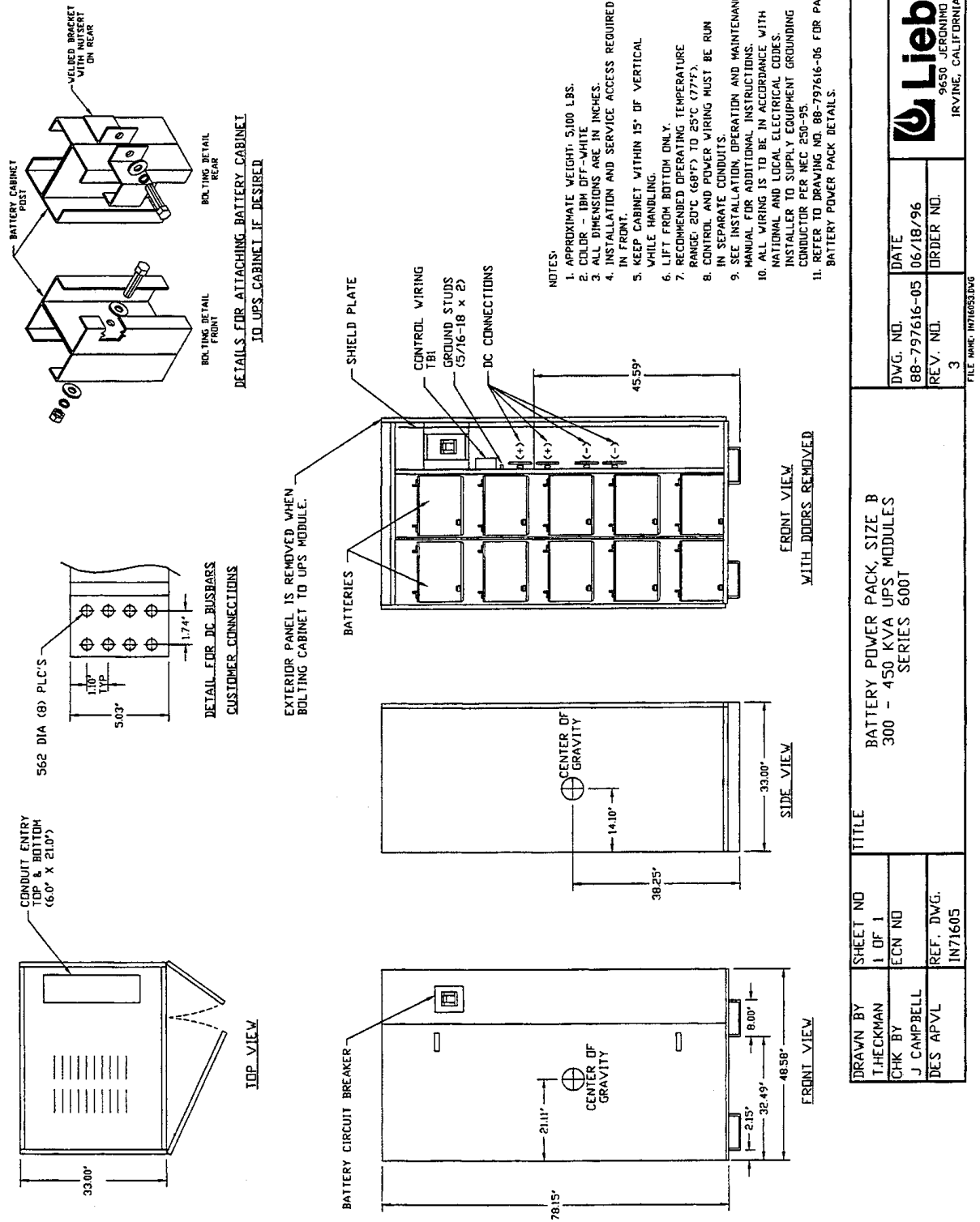


DWG. NO.	DATE
88-797616-04	05/18/96
REV. NO.	ORDER NO.
3	

FILE NAME: IN71604.DWG

TITLE	
BATTERY POWER PACK, SIZE A 300 - 450 KVA UPS MODULES SERIES 600T	
DRAWN BY	SHEET NO
THECKMAN	1 OF 1
CHK BY	ECN NO
J CAMPBELL	
DES APVL	REF. DWG.
	IN71604

Figure 20 Outline Drawing, Battery Cabinet, Size B

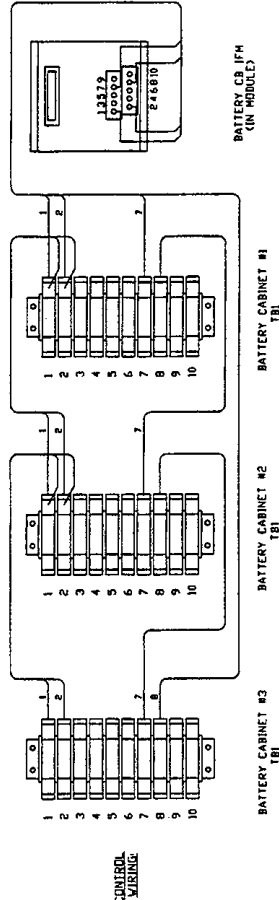
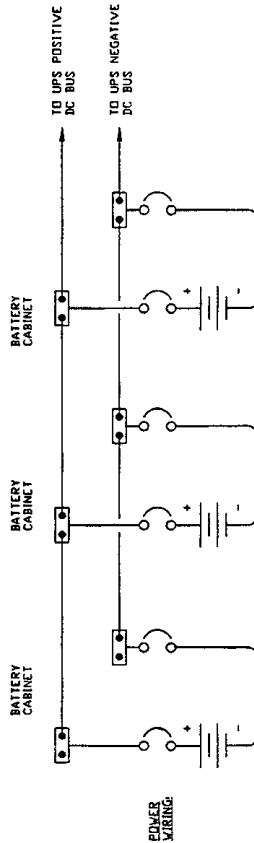
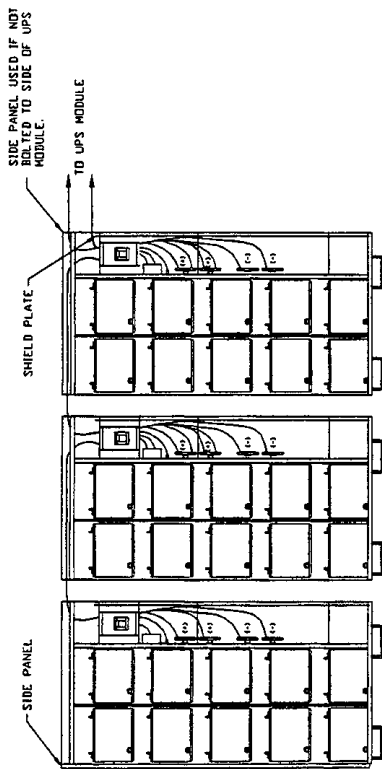
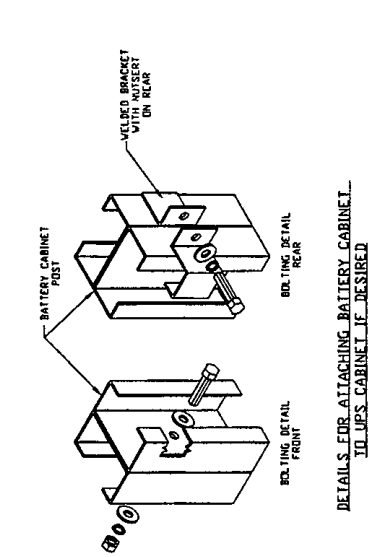


- NOTES:
1. APPROXIMATE WEIGHT: 5,100 LBS.
  2. COLOR - 1BM OFF-WHITE
  3. ALL DIMENSIONS ARE IN INCHES.
  4. INSTALLATION AND SERVICE ACCESS REQUIRED IN FRONT.
  5. KEEP CABINET WITHIN 15° OF VERTICAL WHILE HANDLING.
  6. LIFT FROM BOTTOM ONLY.
  7. RECOMMENDED OPERATING TEMPERATURE RANGE: 20°C (68°F) TO 25°C (77°F).
  8. CONTROL AND POWER WIRING MUST BE RUN IN SEPARATE CONDUITS.
  9. SEE INSTALLATION, OPERATION AND MAINTENANCE MANUAL FOR ADDITIONAL INSTRUCTIONS.
  10. ALL WIRING IS TO BE IN ACCORDANCE WITH NATIONAL AND LOCAL ELECTRICAL CODES. INSTALLER TO SUPPLY EQUIPMENT GROUNDING CONDUCTOR PER NEC 250-95.
  11. REFER TO DRAWING NO. 88-797616-06 FOR PARALLEL BATTERY POWER PACK DETAILS.

DRAWN BY T.HECKMAN		SHEET NO 1 OF 1		TITLE BATTERY POWER PACK, SIZE B 300 - 450 KVA UPS MODULES SERIES 600T	
CHK BY J.CAMPBELL		ECN NO		DWG. NO. 88-797616-05	
DES APVL		REF. DWG. IN71605		DATE 06/18/96	
				ORDER NO.	
				REV. NO. 3	
				FILE NAME: IN71605.DWG	



Figure 21 Installation Drawing, Parallel Battery Cabinets

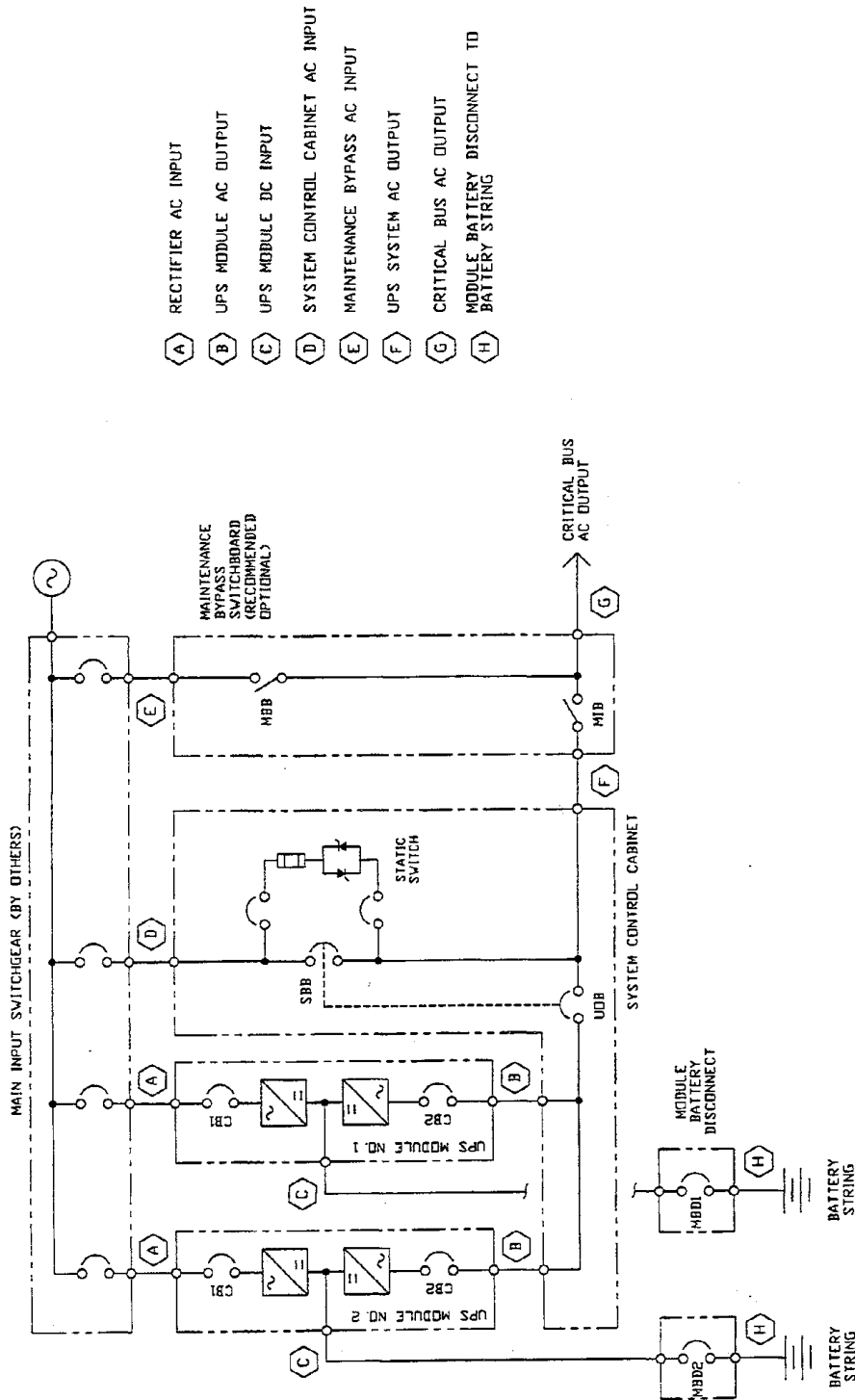


- NOTES:
1. ALL CABLE CONNECTIONS MADE BEFORE BOLTING SEPARATE CABINETS TOGETHER.
  2. ALL CABINETS SHOWN WITH FRONT PANELS REMOVED.
  3. BATTERY CABINETS MAY BE LOCATED ON RIGHT SIDE OF UPS MODULE IF OTHER OPTIONAL CABINETS ARE NOT INCLUDED IN SYSTEM.
  4. BATTERY CABINETS MAY BE LOCATED REMOTELY FROM THE UPS MODULE. A SEPARATE BATTERY BREAKER MAY BE REQUIRED.
  5. MAXIMUM OF (3) CABINETS CAN BE PUT IN PARALLEL.
  6. ALL HARDWARE SUPPLIED WITH BATTERY CABINETS FOR BOLTING CABINETS TOGETHER. REMOVE SIDE PANEL FROM EACH CABINET SIDE WHEN CABINETS ARE TO BE BOLTED TOGETHER.
  7. USE 3/8-16 INCH PROVIDED ASSEMBLY AS SHOWN. BOLT, FLAT WASHER - FLATWASHER, LOCKWASHER, NUT. BOLT THROUGH HOLES PROVIDED ON CORNER POSTS.
  8. USE INCH PROVIDED. BOLT CLAMP TO REAR CORNER POSTS WHEN FLAT WASHERS IS NOT AVAILABLE AS IN NOTE 7. (BOLT, LOCKWASHER, FLATWASHER)
  9. SEE INSTALLATION OPERATION AND MAINTENANCE MANUAL FOR ADDITIONAL INSTRUCTIONS.
  10. ALL WIRING IS TO BE IN ACCORDANCE WITH NATIONAL AND LOCAL ELECTRICAL CODES. REFER TO SUPPLY EQUIPMENT GROUNDING CONDUCTORS PER NEC 250-95.

DRAWN BY T.HECKMAN		SHEET NO 1 OF 1		TITLE PARALLEL BATTERY POWER PACK 300 - 450 KVA UPS MODULES SERIES 600T	
CHK BY J.CAMPBELL		ECN NO		REF. DWG. IN71606	
DES APVL IN71606		REV. DWG.		FILE NAME: IN71606.DWG	
DWG. NO. 88-797616-06		DATE 06/18/96		ORDER NO.	
REV. NO. 3					



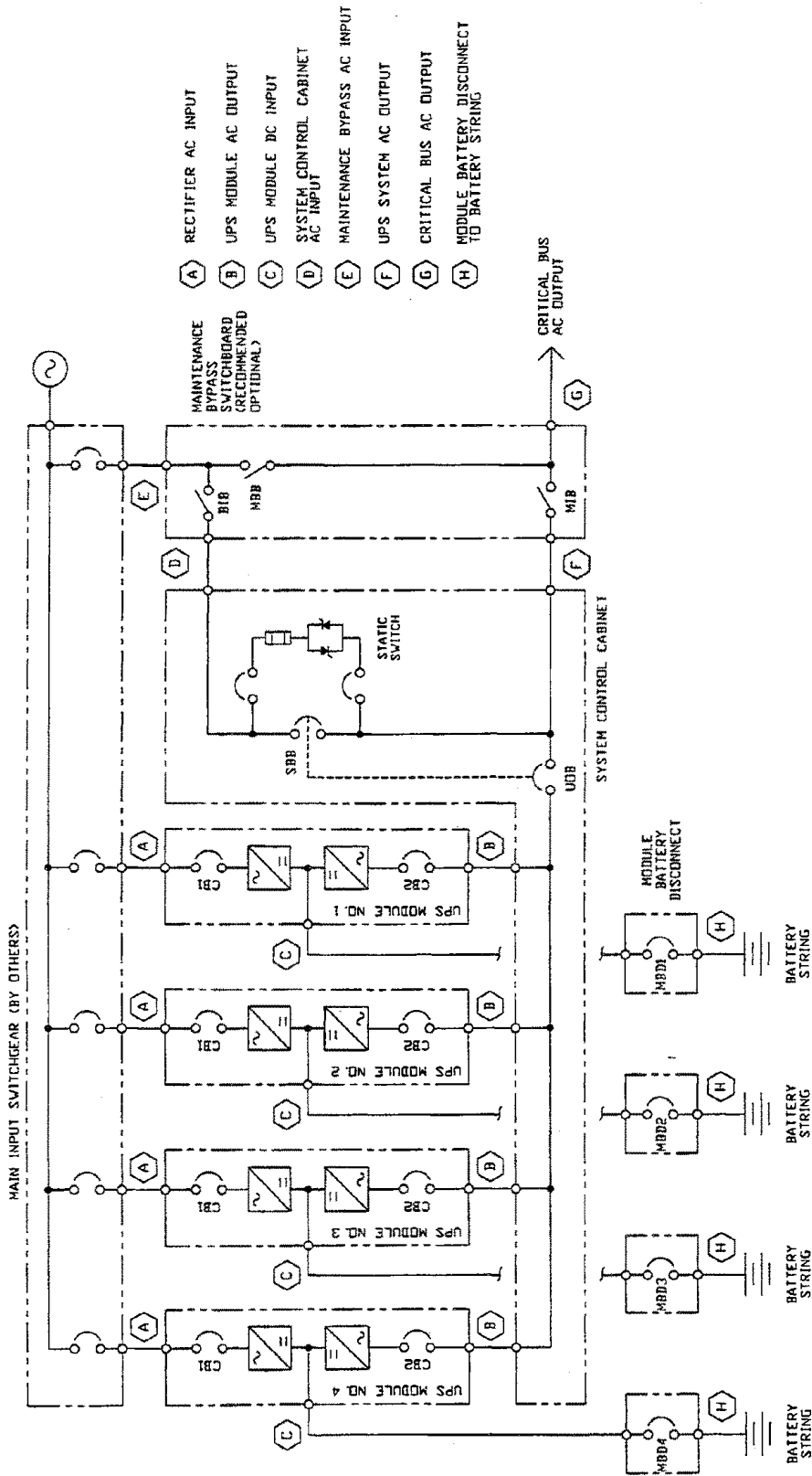
Figure 22 One-Line Diagram, 2-Module Parallel System With 2-Breaker Maintenance Bypass



DRAWN BY B. FISH		SHEET NO. 1 OF 1	
CHK BY J. CAMPBELL		ECN NO.	
DES. APVL. REF. DWG. SL61437		REV. NO. 1	
DWG. NO. 97-791614-37		DATE 06/09/95	
REV. NO. 1		ORDER NO.	
TITLE ONE-LINE DIAGRAM TWO MODULE PARALLEL SYSTEM SCCB WITH TWO BREAKER MAINTENANCE BYPASS SERIES 600			
9650 JERONIMO RD. IRVINE, CALIFORNIA 92718			

FILE NAME: SC64371.BWG

Figure 23 One-Line Diagram, 4-Module Parallel System With 3-Breaker Maintenance Bypass

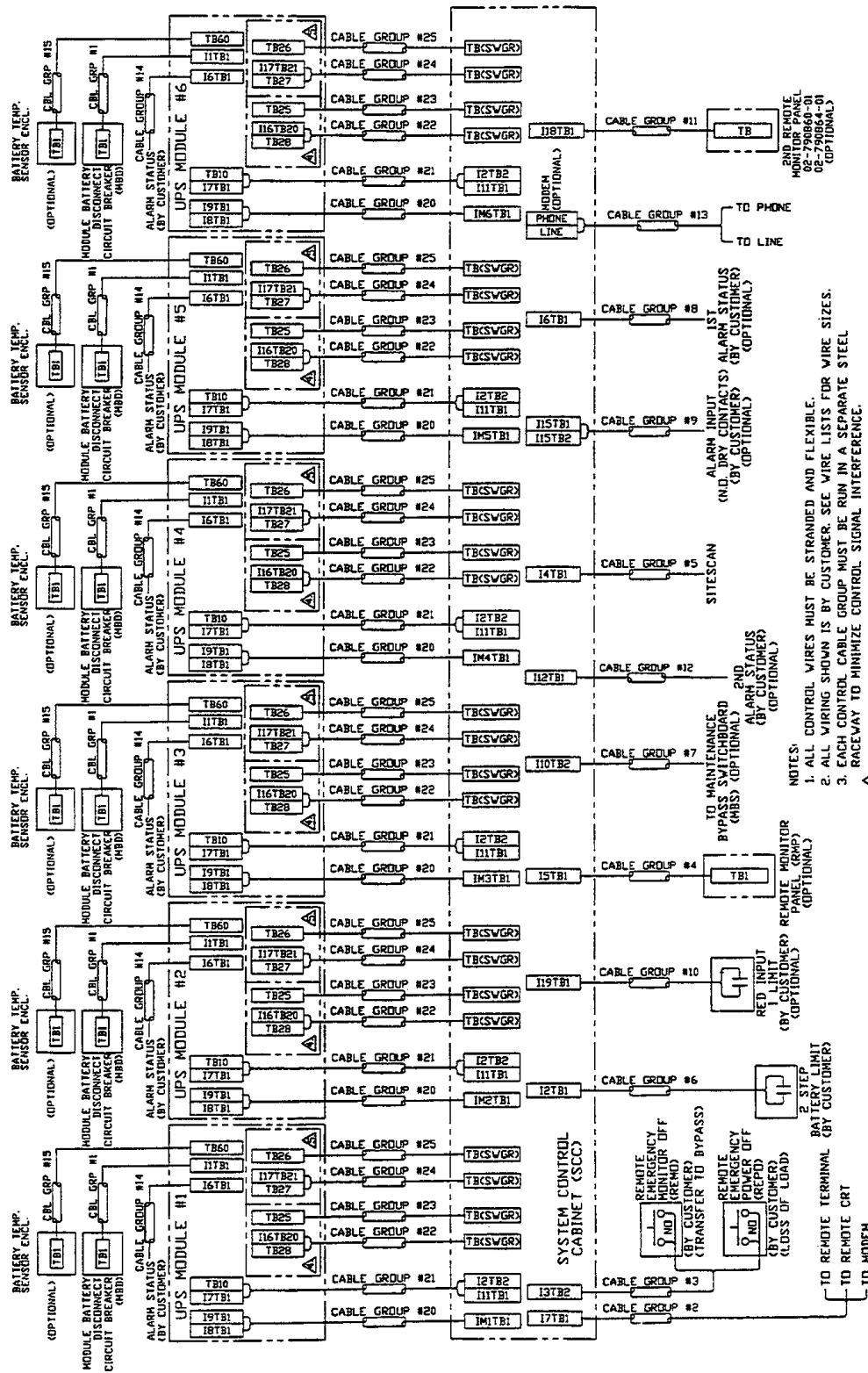


- (A) RECTIFIER AC INPUT
- (B) UPS MODULE AC OUTPUT
- (C) UPS MODULE DC INPUT
- (D) SYSTEM CONTROL CABINET AC INPUT
- (E) MAINTENANCE BYPASS AC INPUT
- (F) UPS SYSTEM AC OUTPUT
- (G) CRITICAL BUS AC OUTPUT
- (H) MODULE BATTERY DISCONNECT TO BATTERY STRING

DRAWN BY B FISH		SHEET NO 1 OF 1		TITLE ONE-LINE DIAGRAM FOUR MODULE PARALLEL SYSTEM SCCB WITH THREE BREAKER MAINTENANCE BYPASS SERIES 600	
CHK BY J CAMPBELL		ECN NO		DATE 06/09/95	
DES APVL		REF. DWG. SL61444		ORDER NO.	
				REV. NO. 1	
				FILE NAME 318144130G	



Figure 24 Control Wiring Interconnect Diagram

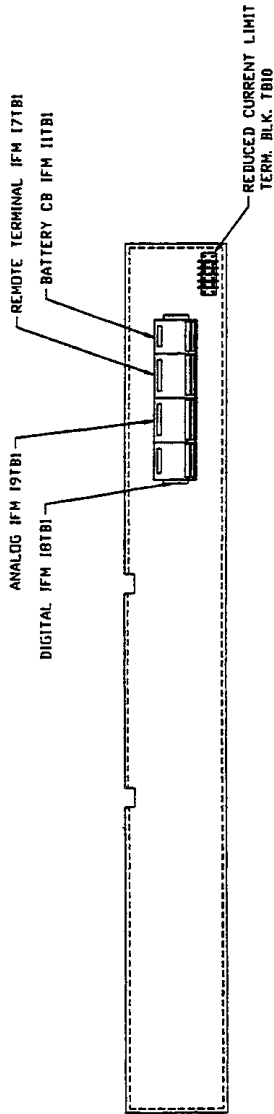


- NOTES:
1. ALL CONTROL WIRES MUST BE STRANDED AND FLEXIBLE.
  2. ALL WIRING SHOWN IS BY CUSTOMER. SEE WIRE LISTS FOR WIRE SIZES.
  3. EACH CONTROL CABLE GROUP MUST BE RUN IN A SEPARATE STEEL RACEWAY TO MINIMIZE CONTROL SIGNAL INTERFERENCE.
- △ REMOTE INPUT CB (OPTIONAL) SCCC/SCCI ONLY  
 ▽ REMOTE OUTPUT CB (OPTIONAL) SCCC/SCCI ONLY

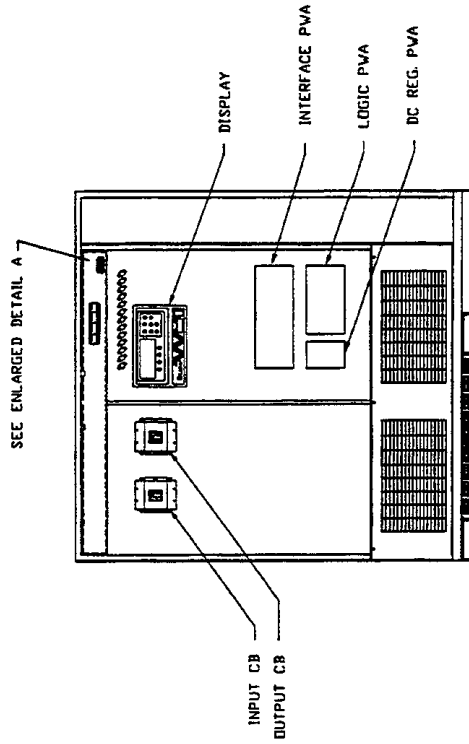
DRAWN BY T. HECKMAN		SHEET NO 1 OF 1	
CHK BY J. CAMPBELL		ECN NO	
DES. APVL WD71951		REF. DWG.	
TITLE CONTROL WIRE LIST INTERCONNECT DIAGRAM MULTI - MODULE UPS SYSTEM 300 - 450 KVA SERIES 600T		DWG. NO. 96-797619-51	DATE 05/29/96
		REV. NO. 1	ORDER NO.



Figure 25 Control Connection Location Diagram, Multi-Module Unit



ENLARGED\_DETAIL\_A



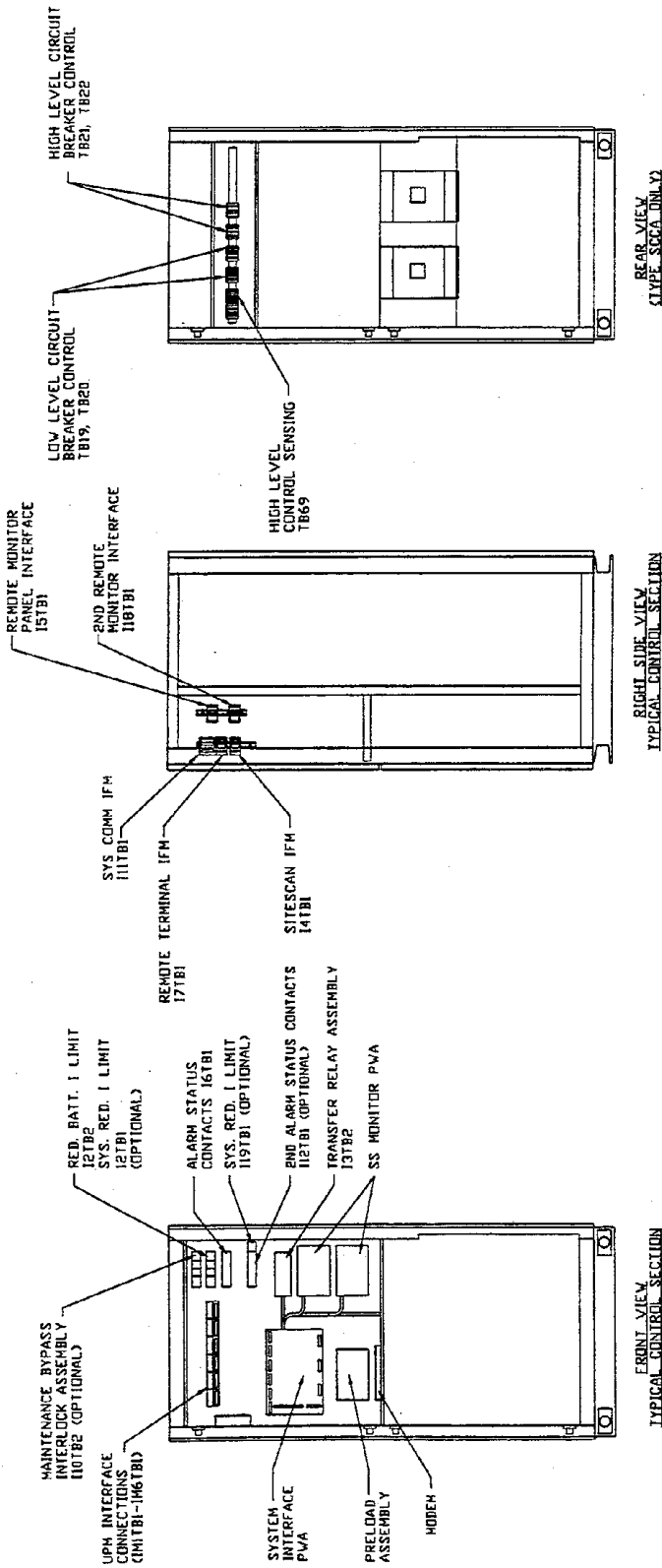
FRONT\_VIEW

DRAWN BY T HECKMAN	SHEET NO 1 OF 1	TITLE CONTROL CONNECTION MULTI - MODULE SYSTEM LOCATION DIAGRAM 300 - 450 KVA SERIES 600T	
	CHK BY J CAMPBELL DES APVL	ECN NO	
	REF. DWG. CC71946	DWG. NO. 96-797619-46	DATE 05/28/96
		REV. NO. 1	ORDER NO.
		 9650 JEROME RD. IRVINE, CALIFORNIA 92718	

FILE NAME: CC71946.DWG



Figure 26 Control Connection Location Diagram, System Control Cabinet




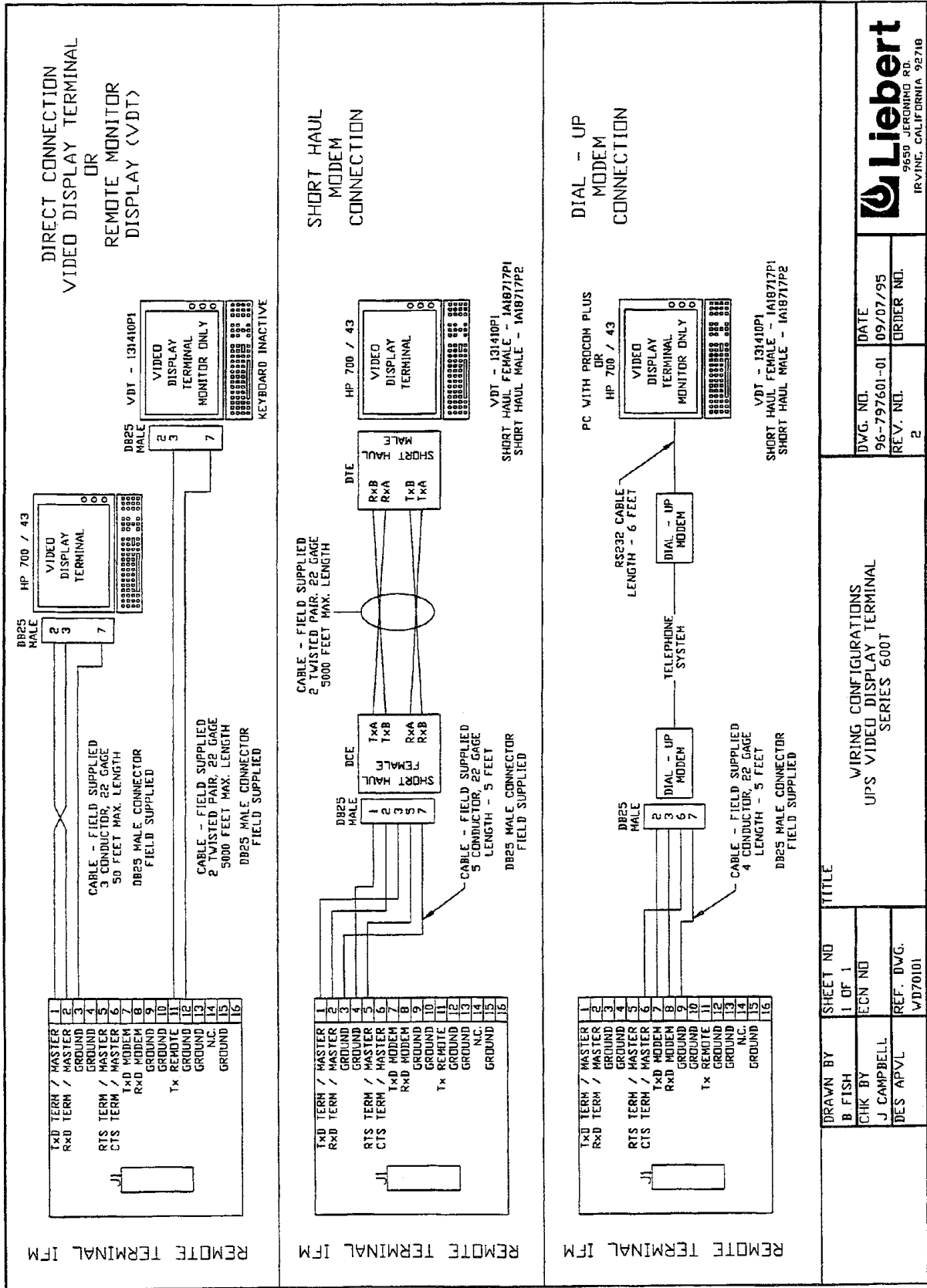

DRAWN BY B FISH		SHEET NO 1 OF 1		TITLE CONTROL CONNECTION LOCATION DIAGRAM	
CHK BY J CAMPBELL		ECN NO		MULTI - MODULE SYSTEM CONTROL CABINET SERIES 600T	
DES APVL DES APVL		REF. DWG. CC71918		DATE 05/26/96	
		DWG. NO. 96-797619-18		ORDER NO.	
		REV. NO. 3		FILE NAME: CCP1918.DWG	
 9650 JERONIMO RD. IRVING, CALIFORNIA 92710					

Figure 27 Video Display Terminal Wiring

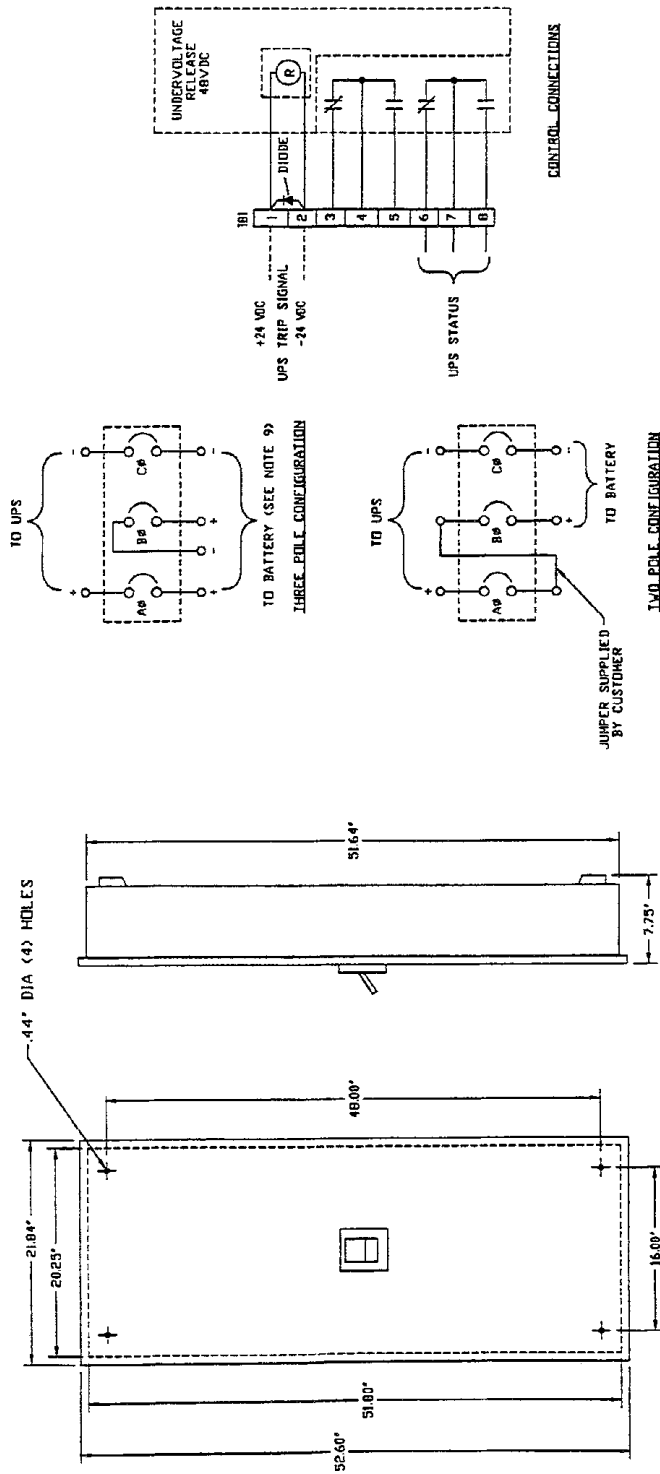


DRAWN BY B FISH		SHEET NO 1 OF 1		TITLE WIRING CONFIGURATIONS UPS VIDEO DISPLAY TERMINAL SERIES 600T	
CHK BY J CAMPBELL		ECN NO		DWG. NO. 96-797601-01	
DES APVL		REF. DWG. VD70101		DATE 10/07/95	
				ORDER NO.	
				REV. NLI 2	


**Liebert**  
 9650 JERCINING RD.  
 IRVINE, CALIFORNIA 92718

FILE NAME: VDT002R26V6

Figure 28 Module Battery Disconnect, Systems With Isolation Transformer

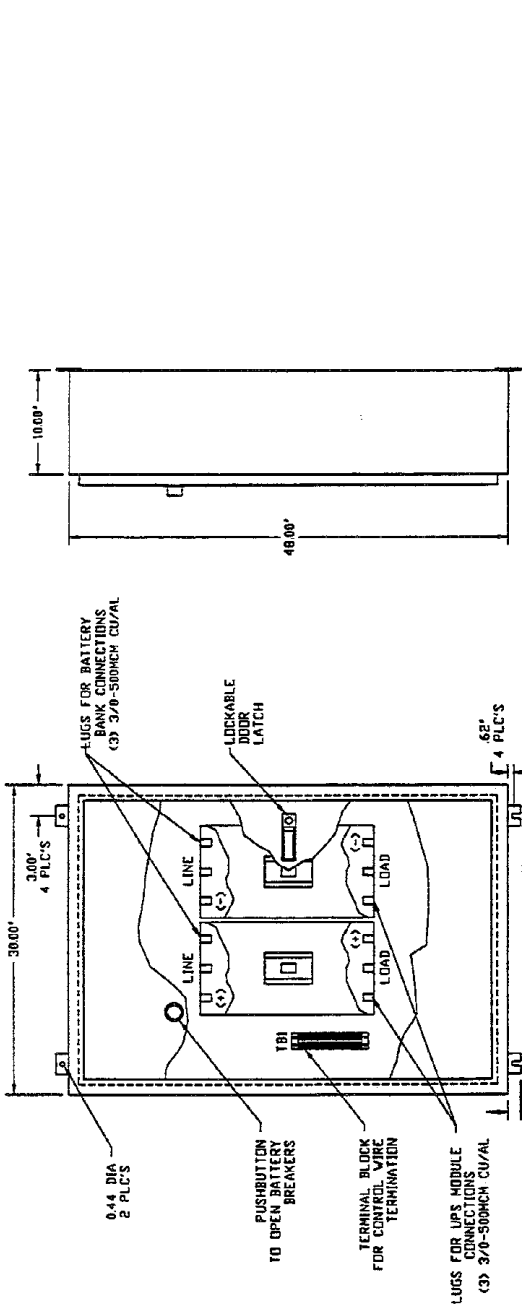


- NOTES:
1. NEMA 1 ENCLOSURE PROVIDED WHICH IS SUITABLE FOR WALL MOUNTING ONLY.
  2. CIRCUIT BREAKER, SQUARE D TYPE HIL36XXXX BREAKER, 600 VDC, INCLUDES 2CA/2B AUXILIARY CONTACTS, AND A 48VDC TRIP UNIT.
  3. WIRING TERMINALS PROVIDED FOR FIELD WIRING CONNECTIONS.
  4. FINISH IS GRAY BAKED ENAMEL.
  5. FOR APPLICATIONS WHERE A TWO POLE CONFIGURATION IS REQUIRED THE CUSTOMER MUST ADD A CABLE JUMPER OF EQUAL AMPACITY TO THE BATTERY CIRCUIT CONDUCTORS AS SHOWN ON THIS DRAWING.
  6. CABLE CONNECTION LUG SIZE IS (3) 3/8 AWG-500HCH CU. FOR 300A - 1000A.
  7. APPROXIMATE WEIGHT IS 150 LBS.
  8. CIRCUIT BREAKER INSTANTANEOUS TRIP SETTING SHOULD BE SET AT THE MIDDLE OF THE ADJUSTMENT RANGE. FOR 600A - 1000A BREAKERS THIS RANGE IS 100% TO 150% OF THE RATED CURRENT. FOR 300A & 450A BREAKERS, CENTER POLE USED TO BREAK MIDDLE OF BATTERY STRING.
  9. GROUND LUGS ARE PROVIDED FOR (4) #6-250MCM CONDUCTORS.

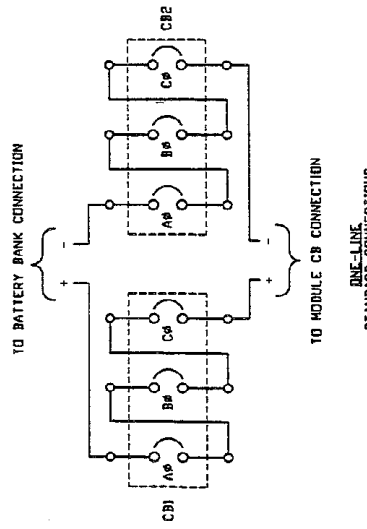
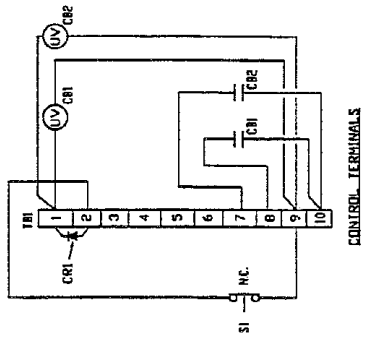
DRAWN BY K. SCHILLER		SHEET NO 1 OF 1		TITLE INSTALLATION DRAWING 300, 450, 600, 800, 1000 AMP MODULE BATTERY DISCONNECT WITH INPUT ISOLATION TRANSFORMER	
CHK BY J CAMPBELL		ECN NO		DWG. NO. 98-797616-09	
DES APVL IN71609		REF. DWG.		DATE 05/31/96	
		REV. NO. 2		ORDER NO.	



Figure 29 Module Battery Disconnect, Systems Without Isolation Transformer



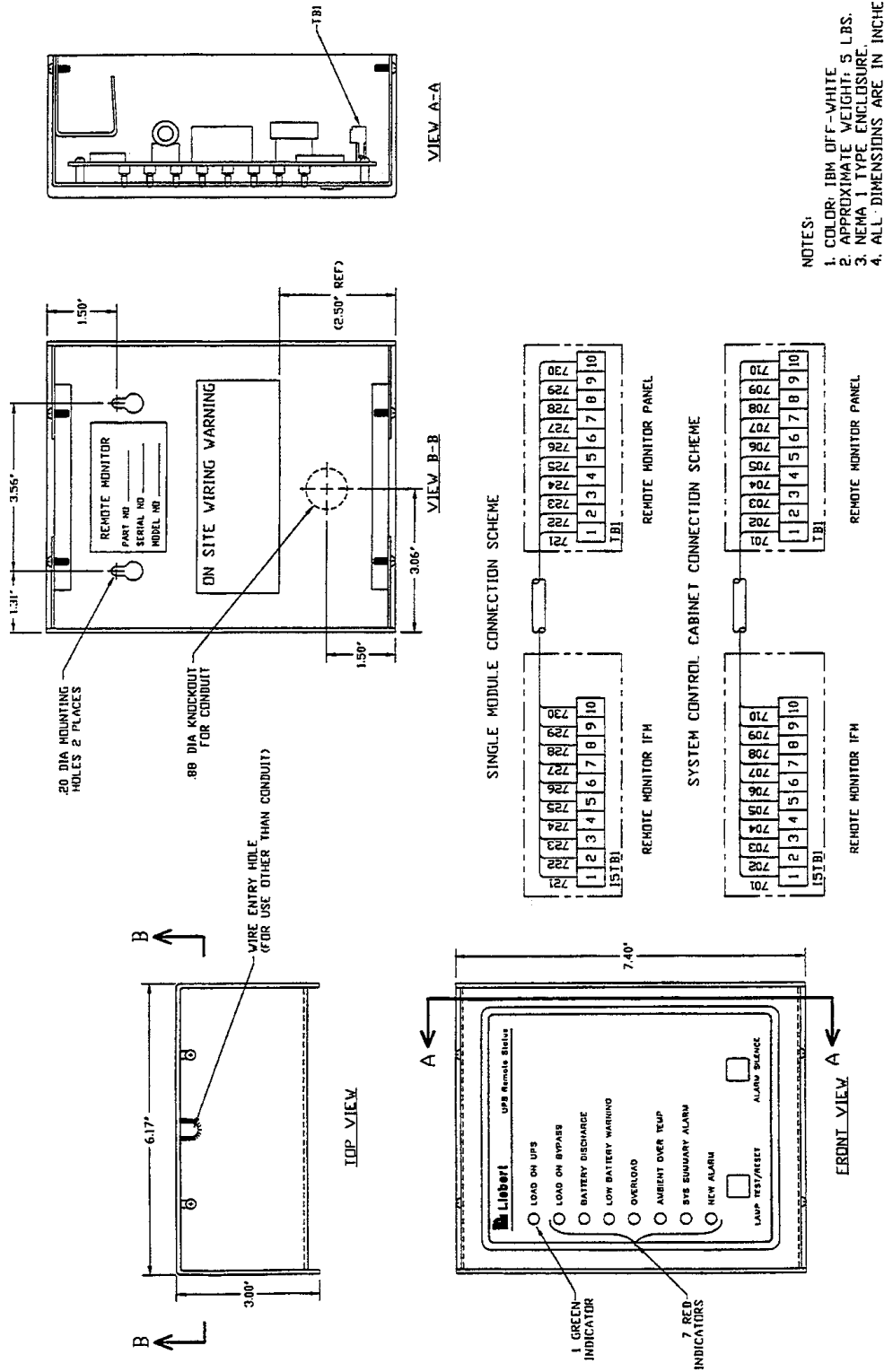
- NOTES:
1. NEMA 12 ENCLOSURE PROVIDED WHICH IS SUITABLE FOR WALL MOUNTING ONLY.
  2. CIRCUIT BREAKER, SQUARE D TYPE MH.36XXXX BREAKER, 600 VDC, UNDERVOLTAGE RELEASE.
  3. FINISH IS GRAY BAKED ENAMEL.
  4. CABLE CONNECTION LUG SIZE IS (3) 3/8 AWG-500MCH CU FOR 600 - 1000A.
  5. APPROXIMATE WEIGHT IS 200 LBS.
  6. CIRCUIT BREAKER INSTANTANEOUS TRIP SETTING SHOULD BE SET AT THE MIDPOINT OF THE ADJUSTMENT RANGE FOR 600A - 1000A BREAKERS.



DWG. NO. 88-797616-07		DATE 05/31/96	
REV. NO. 3		ORDER NO.	
FILE NAME: IN71607.DWG			
INSTALLATION DRAWING 600, 800, 1000 AMP MODULE BATTERY DISCONNECT WITHOUT INPUT ISOLATION TRANSFORMER SERIES 6001			
DRAWN BY K SCHILLER	SHEET NO 1 OF 1	TITLE	
CHK BY J CAMPBELL	ECN NO		
DES APVL IN71607	REF. DWG.		



Figure 30 Remote Status Panel

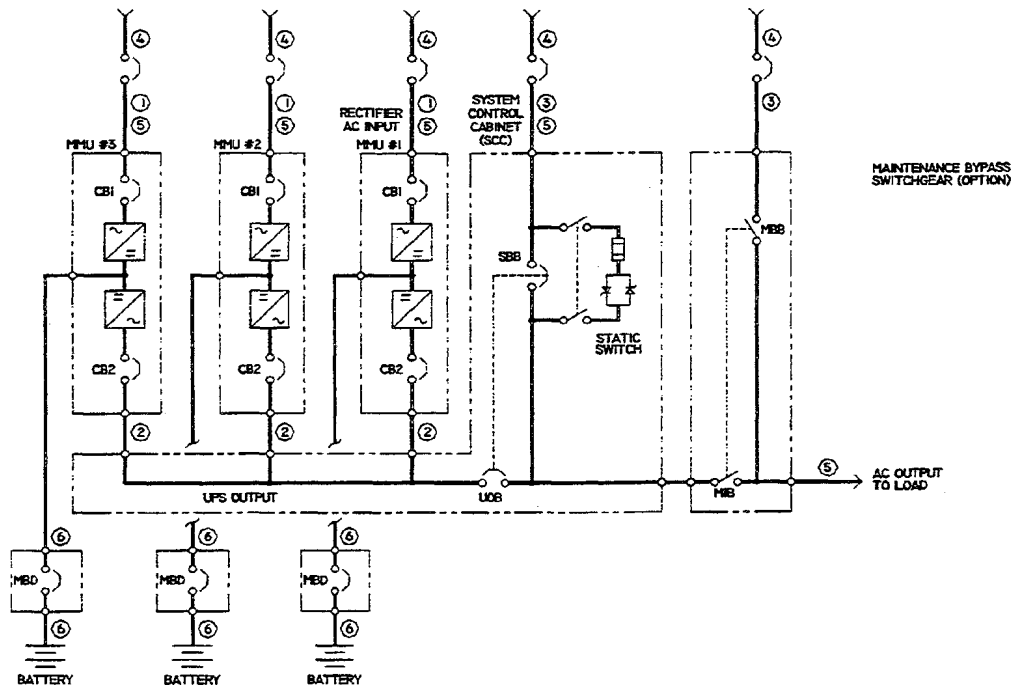


DRAWN BY B FISH		SHEET NO 1 OF 1		TITLE REMOTE STATUS PANEL SURFACE MOUNT SERIES 600	
CHK BY J CAMPBELL		ECN NO		DWG. NO. 88-791617-01	
DES APVL		REF. DWG. IN61701		DATE 06/22/95	
				ORDER NO.	



## 11.0 APPENDIX A - SITE PLANNING DATA

### 300-450 kVA Multi-Module Systems



### 11.1 Notes

- Nominal rectifier AC input current (considered continuous) is based on full rated output load. Maximum current includes nominal input current and maximum battery recharge current (considered noncontinuous). Continuous and noncontinuous current limit are defined in NEC 100. Maximum input current is controlled by current limit setting which is adjustable. Values shown for maximum setting are 125% of nominal input current. Standard factory setting is 115%.
- Nominal AC output current (considered continuous) is based on full rated output load. Maximum current includes nominal output current and overload current for 10 minutes.
- Bypass AC input current (considered continuous) is based on full rated output load.
- Feeder protection (by others in external equipment) for rectifier AC input and bypass AC input is recommended to be provided by separate overcurrent protection devices.
- UPS output load cables must be run in separate conduit from input cables.
- Power cable from module DC bus to battery should be sized for a total maximum 2.0 volt line drop (measured at the module) at maximum discharge current.
- Grounding conductors to be sized per NEC 250-95. Neutral conductors to be sized for full capacity—per NEC 310-16, Note 10—for systems with 4-wire loads and half capacity for systems with 3-wire loads. NOTE: A neutral conductor is required from each Module Unit output to the System Control Cabinet.
- Rectifier AC Input: 3-phase, 3-wire, plus ground  
AC Output to Load: 3-phase, 3 or 4-wire, plus ground  
Bypass AC Input: 3-phase, 3 or 4-wire, plus ground  
Module DC Input from Battery: 2-wire, (positive and negative)
- All wiring is to be in accordance with National and Local Electrical Codes.
- Minimum overhead clearance is 2 feet above UPS.
- Top or bottom cable entry through removable access plates. Cut plate to suit conduit size.
- Control wiring and power cables must be run in separate conduits. Control wiring must be stranded tinned conductors.
- 7% maximum input harmonic current and 0.92 lagging input power factor at full load with optional input filter. 30% maximum input harmonic current and 0.85 lagging input power factor at full load without optional input filter.
- Dimensions and weights do not include the System Control Cabinet required for Module Systems.

**Table 4 Series 600T Multi-Module Systems - 208 Volt Input**

UPS Rating		AC Output Voltage	Options		Rectifier AC Input Current		Inverter or Bypass AC Output Current		Required Battery Disconnect Rating	Maximum Battery Current at End of Discharge	Maximum Heat Dissipation BTU/hr.	Dimensions Inches	Approx. Weight Lb.	Floor Loading Lb./ Sq.Ft.
kVA	kW		Input Filter	Input Transformer	Nom	Max	Nom	Max	Amperes	Amperes	Full Load	(WxDxH)	(Un-packed)	(Distributed Loading)
300	240	208	NO	NO	847	1059	833	1041	600	628	66,425	72x35x79	5,350	306
300	240	208	YES	NO	783	979	833	1041	600	628	66,425	72x35x79	5,520	315
300	240	208	NO	YES	857	1071	833	1041	600	628	81,000	96x35x79	7,450	319
300	240	208	YES	YES	791	989	833	1041	600	628	81,000	96x35x79	7,620	327
375	300	208	NO	YES	1071	1346	1041	1301	800	785	101,250	96x35x79	8,950	384
375	300	208	YES	YES	989	1243	1041	1301	800	785	101,250	96x35x79	9,120	391
<b>Applicable Notes:</b>		—	13	—	1,4,5,7,8,9,11,12		2,3,5,7,8,9,11,12		6	6,8,9,11,12	—	—	—	—

For explanation of notes, see referenced numbers in 11.1 - Notes

**Table 5 Series 600T Multi-Module Systems, 300-450 kVA - 480 Volt Input**

UPS Rating		AC Output Voltage	Options		Rectifier AC Input Current		Inverter or Bypass AC Output Current		Required Battery Disconnect Rating	Maximum Battery Current at End of Discharge	Maximum Heat Dissipation BTU/hr.	Dimensions Inches	Approx. Weight Lb.	Floor Loading Lb./ Sq.ft.
kVA	kW		Input Filter	Input Transformer	Nom	Max	Nom	Max	Amperes	Amperes	Full Load	(WxDxH)	(Un-packed)	(Distributed Loading)
300	240	480	NO	NO	361	452	361	451	600	625	52,275	72x35x79	4,150	237
300	240	480	YES	NO	334	417	361	451	600	625	52,275	72x35x79	4,320	247
300	240	480	NO	YES	367	459	361	451	600	625	66,400	96x35x79	6,050	259
300	240	480	YES	YES	339	424	361	451	600	625	66,400	96x35x79	6,220	267
300	240	208	NO	NO	363	454	833	1041	600	628	56,950	72x35x79	4,400	251
300	240	208	YES	NO	336	420	833	1041	600	628	56,950	72x35x79	4,570	261
300	240	208	NO	YES	369	461	833	1041	600	628	71,225	96x35x79	6,500	279
300	240	208	YES	YES	341	426	833	1041	600	628	71,225	96x35x79	6,670	286
375	300	480	NO	NO	452	565	451	564	800	781	65,350	72x35x79	4,850	277
375	300	480	YES	NO	417	522	451	564	800	781	65,350	72x35x79	5,020	287
375	300	480	NO	YES	459	574	451	564	800	781	83,025	96x35x79	6,750	289
375	300	480	YES	YES	424	530	451	564	800	781	83,025	96x35x79	6,920	297
375	300	208	NO	NO	454	568	1041	1301	800	785	71,180	72x35x79	5,100	291
375	300	208	YES	NO	420	524	1041	1301	800	785	71,180	72x35x79	5,270	301
375	300	208	NO	YES	461	577	1041	1301	800	785	89,025	96x35x79	7,200	309
375	300	208	YES	YES	426	533	1041	1301	800	785	89,025	96x35x79	7,370	316
450	360	480	NO	NO	542	677	541	677	1000	938	78,426	72x35x79	5,050	216
450	360	480	YES	NO	501	626	541	677	1000	938	78,426	72x35x79	5,220	224
450	360	480	NO	YES	551	688	541	677	1000	938	99,623	96x35x79	6,950	298
450	360	480	YES	YES	509	636	541	677	1000	938	99,623	96x35x79	7,120	305
<b>Applicable Notes:</b>		—	13	—	1,4,5,7,8,9,11,12		2,3,5,7,8,9,11,12		6	6,8,9,11,12	—	—	—	—

For explanation of notes, see referenced numbers in 11.1 - Notes

**Table 6 Series 600T Multi-Module Systems, 600 Volt Input**

UPS Rating		AC Output Voltage	Options		Rectifier AC Input Current		Inverter or Bypass AC Output Current		Required Battery Disconnect Rating	Maximum Battery Current at End of Discharge	Maximum Heat Dissipation BTU/hr.	Dimensions Inches	Approx. Weight Lb.	Floor Loading Lb./ Sq.ft.
kVA	kW		Input Filter	Input Transformer	Nom	Max	Nom	Max	Amperes	Amperes	Full Load	(WxDxH)	(Un-packed)	(Distributed Loading)
300	240	600	NO	NO	289	361	289	361	600	625	52,275	72x35x79	4,550	260
300	240	600	YES	NO	267	334	289	361	600	625	52,275	72x35x79	4,720	270
300	240	600	NO	YES	294	367	289	361	600	625	66,425	96x35x79	6,450	276
300	240	600	YES	YES	271	339	289	361	600	625	66,425	96x35x79	6,620	284
300	240	208	NO	NO	291	363	833	1041	600	628	56,950	72x35x79	4,750	271
300	240	208	YES	NO	268	336	833	1041	600	628	56,950	72x35x79	4,920	281
300	240	208	NO	YES	295	369	833	1041	600	628	71,225	96x35x79	6,850	294
300	240	208	YES	YES	273	341	833	1041	600	632	71,225	96x35x79	7,020	301
375	300	600	NO	NO	361	452	361	451	800	781	65,350	72x35x79	5,350	306
375	300	600	YES	NO	334	417	361	451	800	781	65,350	72x35x79	5,520	315
375	300	600	NO	YES	367	459	361	451	800	781	83,025	96x35x79	7,250	311
375	300	600	YES	YES	339	424	361	451	800	781	83,025	96x35x79	7,420	318
375	300	208	NO	NO	363	454	1041	1301	800	785	71,175	72x35x79	5,550	317
375	300	208	YES	NO	336	420	1041	1301	800	785	71,175	72x35x79	5,720	327
375	300	208	NO	YES	369	461	1041	1301	800	785	89,025	96x35x79	7,650	328
375	300	208	YES	YES	341	426	1041	1301	800	785	89,025	96x35x79	7,820	335
<b>Applicable Notes:</b>		—	13	—	1,4,5,7,8,9,11,12		2,3,5,7,8,9,11,12		6	6,8,9,11,12	—	—	1	—

For explanation of notes, see referenced numbers in 11.1 - Notes

**Table 7 Battery Pack**

kVA	Time (Min.) 100% Load	Cabinets in Parallel	Overall Dimensions WxDxH (Inches)	Overall Weight (Lb.)
300	6	2	85x33x79	6,760
300	13	3	127x33x79	10,140
300	17	3	127x33x79	11,340
375	5	2	85x33x79	7,560
375	12	3	127x33x79	11,340
375	16	3	127x33x79	14,700
450	7	3	127x33x79	11,340
450	12	3	127x33x79	14,700

NOTE: Battery cabinet depth is approximately two inches less than UPS module depth

**Table 8 UPS Efficiency, All kVA / kW Ratings**

Input Voltage	Output Voltage	Efficiency @ 50% Load	Efficiency @ 75% Load	Efficiency @ 100% Load
208	208	93	92.5	92.5
480	208	93	93.5	93.5
480	480	93	94	94
600	208	93	93.5	93.5
600	600	93	94	94

- For all input/output voltages, subtract approximately 1.5% from full load efficiency for units with input isolation transformer
- All efficiencies measured with non-linear load at 0.8 power factor



---

## System Control Cabinets

Multi-Module Systems are provided with a system control cabinet. Cabinets are available to match load current.

**Table 9 System Control Cabinets**

Type	Amps	Overall Dimensions WxDxH (Inches)	Weight (Lb.)
SCCB	800	37.5x37.5x78	1,100
SCCB	1280	61x50x78	2,000
SCCB	1600	61x50x78	2,000
SCCB	2000	61x50x78	2,370
SCCB	2500	61x50x78	2,370
SCCB	3000	61x50x78	2,370
SCCP	200-960	37x37x78	1,000
SCCP	1120-1600	37.5x50x78	1,250
SCCP	2000	37.5x50x78	1,400

## 12.0 APPENDIX B - FIELD SUPPLIED LUGS

**Table 10 One-Hole Lugs**

	<b>T &amp; B<sup>1</sup> Lug Style</b>	<b>Wire Size</b>	<b>Bolt Size (Inches)</b>	<b>Tongue Width (Inches)</b>	<b>T &amp; B<sup>1</sup> P/N</b>	<b>Liebert P/N</b>
1	<b>Stak-On</b>	1/0 AWG	3/8	0.88	J973	12-714255-56
2		2/0 AWG	3/8	1.00	K973	12-714255-66
3		3/0 AWG	3/8	1.10	L973	12-714255-76
4		4/0 AWG	3/8	1.20	M973	12-714255-86
5	<b>Color-Keyed Aluminum/ Copper</b>	1/0 AWG	3/8	0.93	60130	—
6		2/0 AWG	3/8	0.97	60136	—
7		3/0 AWG	3/8	1.06	60142	—
8	<b>Color-Keyed Copper Cable Long Barrel</b>	1/0 AWG	3/8	0.75	54909BE	—
9		2/0 AWG	3/8	0.81	54910BE	—
10		3/0 AWG	1/2	0.94	54965BE	—
11		4/0 AWG	1/2	1.03	54970BE	—
12		250MCM	1/2	1.09	54913BE	—
13	<b>Narrow-Tongue Copper Cable</b>	350MCM	1/2	1.09	55165	—
14		500MCM	1/2	1.20	55171	—

<sup>1</sup> NOTE: Manufacturer Thomas & Betts (T & B), 1-800-862-8324



## Series 600T™ UPS

Multi-Module Three Phase

300 kVA to 450 kVA; 60 Hz

### Technical Support

U.S.A. 1-800-222-5877  
Outside the U.S.A. 614-841-6755  
U.K. +44 (0) 1793 553355  
France +33 1 4 87 51 52  
Germany +49 89 99 19 220  
Italy +39 2 98250 1  
Netherlands +00 31 475 503333  
E-mail [upstech@liebert.com](mailto:upstech@liebert.com)  
Web site <http://www.liebert.com>  
Worldwide FAX 614-841-5471  
tech support

### The Company Behind The Products

With more than 500,000 installations around the globe, Liebert is the world leader in computer protection systems. Since its founding in 1965, Liebert has developed a complete range of support and protection systems for sensitive electronics:

- Environmental systems: close-control air conditioning from 1.5 to 60 tons.
- Power conditioning and UPS with power ranges from 250 VA to more than 1000 kVA.
- Integrated systems that provide both environmental and power protection in a single, flexible package.
- Monitoring and control — on-site or remote — from systems of any size or location

Service and support, through more than 100 service centers around the world, and a 24-hour Customer Response Center.

While every precaution has been taken to ensure accuracy and completeness of this literature, Liebert Corporation assumes no responsibility, and disclaims all liability for damages resulting from use of this information or for any errors or omissions.

© 1998 Liebert Corporation. All rights reserved throughout the world. Specifications subject to change without notice.

® Liebert and the Liebert logo are registered trademarks of Liebert Corporation. All names referred to are trademarks or registered trademarks of their respective owners.

Printed in U.S.A.

SL-30526