

**DISCONTINUED
PRODUCT**

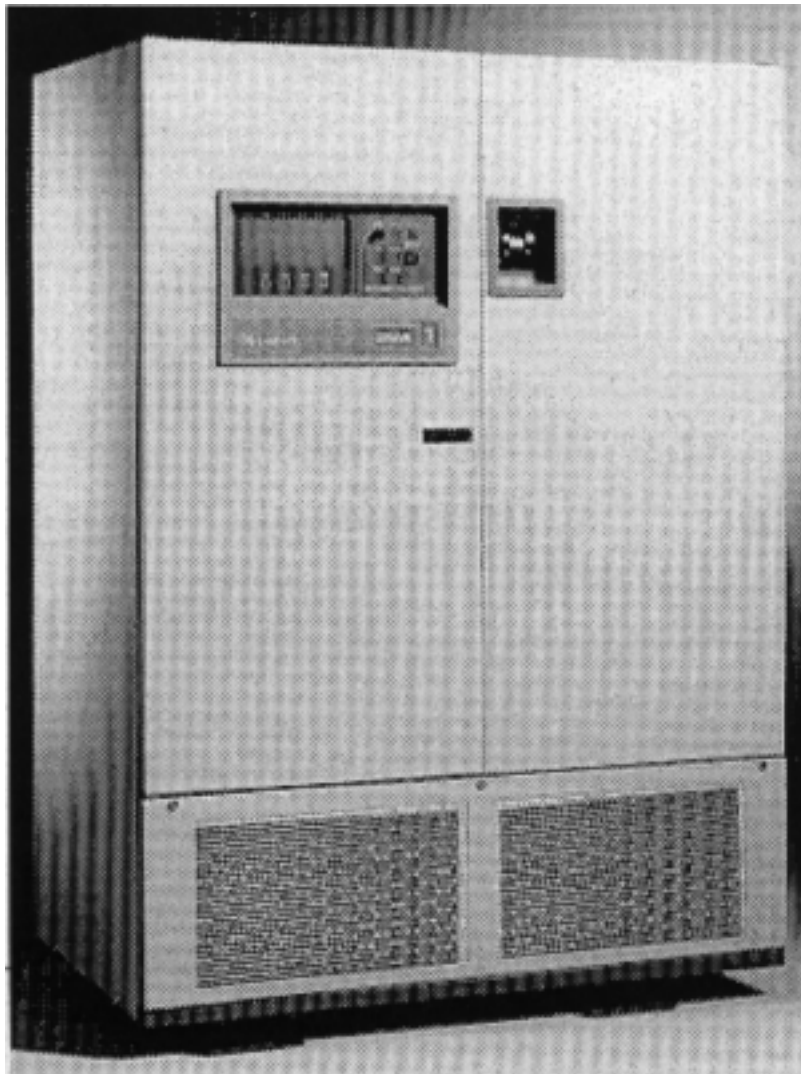


POWER PROTECTION

Series 600™ UPS

**Multi-Module Three Phase
338 kVA to 1000 kVA; 60 Hz**

**Installation
Manual**



**DISCONTINUED
PRODUCT**

TABLE OF CONTENTS

IMPORTANT SAFETY INSTRUCTIONS	1
1.0 SAFETY PRECAUTIONS	3
2.0 INSTALLATION CONSIDERATIONS	5
3.0 UNLOADING AND HANDLING	7
4.0 INSPECTIONS	8
4.1 External Inspections	8
4.2 Internal Inspections	8
5.0 EQUIPMENT LOCATION	10
6.0 BATTERIES	11
6.1 Battery Safety Precautions	11
6.2 Battery Installation	13
7.0 WIRING CONSIDERATIONS	14
7.1 Power and Control Wiring	17
7.2 Battery Wiring	17
8.0 WIRING CONNECTIONS	18
9.0 WIRING INSPECTION	19
10.0 APPENDIX A - SERIES 600 UPS SITE PLANNING DATA	85
10.1 Notes	85

FIGURES

Figure 1	Multi-Module 338 kVA UPS	4
Figure 2	Multi-Module 400 to 1000 kVA UPS	6
Figure 3	System Control Cabinets	9
Figure 4	Typical Multi-Module Configurations	15
Figure 5	Outline Drawing, 338 kVA	21
Figure 6	Outline Drawing, 400 kVA	22
Figure 7	Outline Drawing, 500 kVA	23
Figure 8	Outline Drawing, 500 kVA, 208 VAC	24
Figure 9	Outline Drawing, 625 kVA	25
Figure 10	Outline Drawing, 750 kVA (High Link - 240 Cells)	26
Figure 11	Outline Drawing, 750 kVA (Low Link - 180 Cells)	27
Figure 12	Outline Drawing, 1000 kVA	28
Figure 13	Outline Drawing, System Control Cabinet (SCCB) 640 to 800 Amps	29
Figure 14	Outline Drawing, System Control Cabinet (SCCB) 1280 to 1600 Amps	30
Figure 15	Outline Drawing, System Control Cabinet (SCCB) 2000 to 3000 Amps	31
Figure 16	Outline Drawing, System Control Cabinet (SCCB) 4000 Amps	32
Figure 17	Outline Drawing, System Control Cabinet (SCCP) 200 to 480 Amps	33
Figure 18	Outline Drawing, System Control Cabinet (SCCP) 560 to 960 Amps	34
Figure 19	Outline Drawing, System Control Cabinet (SCCP) 1280 to 2000 Amps	35
Figure 20	Outline Drawing, System Control Cabinet (SCCA) 2000 to 4000 Amps	36
Figure 21	Base Mounting Details, 338 kVA	37
Figure 22	Base Mounting Details, 400 and 500 kVA	38
Figure 23	Base Mounting Details, 400 and 500 kVA, 208 VAC, Rectifier and Inverter Sections	39
Figure 24	Base Mounting Details, 400 and 500 kVA, 208 VAC, Control and Output Sections	40
Figure 25	Base Mounting Details, 625 kVA and 750 kVA (High Link - 240 Cells)	41
Figure 26	Base Mounting Details, 750 kVA (Low Link - 180 Cells) and 1000 kVA, Rectifier and Inverter Sections	42
Figure 27	Base Mounting Details, 750 kVA (Low Link - 180 Cells) and 1000 kVA, Control Section	43
Figure 28	Base Mounting Patterns, System Control Cabinets (SCCB) 640 to 3000 Amps	44
Figure 29	Base Mounting Patterns, System Control Cabinets (SCCB) 4000 Amps	45
Figure 30	Base Mounting Patterns, System Control Cabinets (SCCP) 200 to 480 Amps	46
Figure 31	Base Mounting Patterns, System Control Cabinets (SCCP) 560 to 2000 Amps	47
Figure 32	Base Mounting Patterns, System Control Cabinets (SCCA) 1600 to 4000 Amps	48
Figure 33	Shipping Split Detail, 338 kVA	49
Figure 34	Shipping Split Detail, 400 and 500 kVA	50
Figure 35	Shipping Split Detail, 400 and 500 kVA, 208 VAC	51
Figure 36	Shipping Split Detail, 625 kVA	52
Figure 37	Shipping Split Detail, 750 kVA (High Link - 240 Cells)	53
Figure 38	Shipping Split Detail, 750 kVA (Low Link - 180 Cells) and 1000 kVA	54
Figure 39	Optional Shipping Split Detail, 400 to 625 kVA	55
Figure 40	Optional Shipping Split Detail, 750 kVA	56
Figure 41	Optional Shipping Split Detail, System Control Cabinet (SCCA) 4000 Amps	57
Figure 42	Bussing Details, 338 kVA	58
Figure 43	Bussing Details, 400 kVA	59
Figure 44	Bussing Details, 500 kVA	60
Figure 45	Bussing Details, 500 kVA, 208 VAC	61
Figure 46	Bussing Details, 625 kVA	62
Figure 47	Bussing Details, 750 kVA (High Link - 240 Cells)	63
Figure 48	Bussing Details, 750 kVA (Low Link - 180 Cells)	64

Figure 49	Bussing Details, 1000 kVA	65
Figure 50	Module One-Line Diagram, 338 kVA	66
Figure 51	Module One-Line Diagram, 400 kVA	67
Figure 52	Module One-Line Diagram, 500 kVA	68
Figure 53	Module One-Line Diagram, 500 kVA, 208 VAC	69
Figure 54	Module One-Line Diagram, 625 kVA	70
Figure 55	Module One-Line Diagram, 750 kVA (High Link - 240 Cells)	71
Figure 56	Module One-Line Diagram, 750 kVA (Low Link - 180 Cells)	72
Figure 57	Module One-Line Diagram, 1000 kVA	73
Figure 58	One-Line Diagram, System Control Cabinet (SCCA)	74
Figure 59	System One-Line Diagram, Three Modules with Two Breaker Maintenance Bypass	75
Figure 60	System One-Line Diagram, Three Modules with Three Breaker Maintenance Bypass	76
Figure 61	Control Wiring Interconnect Diagram	77
Figure 62	Control Wiring Interconnect Diagram, SCCA and Switchgear	78
Figure 63	Control Connection Location Diagram, Module	79
Figure 64	Control Connection Location Diagram, System Control Cabinet	80
Figure 65	Video Display Terminal Wiring	81
Figure 66	Battery Circuit Breaker	82
Figure 67	Parallel Battery Configurations	83
Figure 68	Remote Status Panel	84

TABLES

Table 1	Power Wiring Terminals - Factory Supplied	19
Table 2	Torque Specifications	19
Table 3	Table 310-16	20
Table 4	338-1000 kVA Multi-Module Unit, 480 Volt - Standard Module	86
Table 5	338-1000 kVA Multi-Module Unit, 480 Volt - Standard Module With Optional Low Distortion Input Filter	86
Table 6	338-500 kVA Multi-Module Unit, 208 Volt - Standard Module	87
Table 7	338-500 kVA Multi-Module Unit, 208 Volt - Standard Module With Optional Low Distortion Input Filter	87
Table 8	338-1000 kVA Multi-Module Unit, 600 Volt - Standard Module	88
Table 9	338-1000 kVA Multi-Module Unit, 600 Volt - Standard Module With Optional Low Distortion Input Filter	88

IMPORTANT SAFETY INSTRUCTIONS

Save These Instructions.

This manual contains important instructions that should be followed during installation of your Series 600 UPS and batteries.



WARNING

EXERCISE EXTREME CARE WHEN HANDLING UPS CABINETS TO AVOID EQUIPMENT DAMAGE OR INJURY TO PERSONNEL. THE UPS MODULE WEIGHT RANGES FROM 8300 POUNDS (3765 KG) TO 17400 POUNDS (7893 KG).

LOCATE CENTER OF GRAVITY SYMBOLS BEFORE HANDLING EACH CABINET. TEST LIFT AND BALANCE THE CABINETS BEFORE TRANSPORTING. MAINTAIN MINIMUM TILT FROM VERTICAL AT ALL TIMES.

MODULES AND SYSTEM CONTROL CABINETS (SCC'S) HAVE HOLES INTENDED FOR RIGGING BARS OR CHAINS. PREVENT CHAINS OR CABLES FROM CONTACTING CABINET BY USING SPREADER BAR AND ADEQUATE PADDING.

MODULES ARE SUPPLIED WITH BOLT-ON BRACKETS FOR USE WITH FORKLIFT. RECTANGULAR HOLES ARE PROVIDED FOR USE WITH ROL-A-LIFTS.

FOLLOW ALL BATTERY SAFETY PRECAUTIONS WHEN INSTALLING, CHARGING, OR SERVICING BATTERIES. IN ADDITION TO THE HAZARD OF ELECTRIC SHOCK, GAS PRODUCED BY BATTERIES CAN BE EXPLOSIVE AND SULFURIC ACID CAN CAUSE SEVERE BURNS.

IN CASE OF FIRE INVOLVING ELECTRICAL EQUIPMENT, ONLY CARBON DIOXIDE FIRE EXTINGUISHERS, OR THOSE APPROVED FOR USE IN ELECTRICAL FIRE FIGHTING, SHOULD BE USED.

EXTREME CAUTION IS REQUIRED WHEN PERFORMING MAINTENANCE.

BE CONSTANTLY AWARE THAT THE UPS SYSTEM CONTAINS HIGH DC AS WELL AS AC VOLTAGES.

CHECK FOR VOLTAGE WITH BOTH AC AND DC VOLTMETERS PRIOR TO MAKING CONTACT.



WARNING

**LOCATE CENTER OF GRAVITY SYMBOLS 
AND DETERMINE UNIT WEIGHT
BEFORE HANDLING CABINET.**

If you require assistance for any reason, call the toll-free Liebert Customer Service & Support number; 1-800-543-2378. For CS&S to assist you expediently, please have the following information available:

Part Numbers: _____
Serial Numbers: _____
kVA Rating: _____
Date Purchased: _____
Date Installed: _____
Location: _____
Input Voltage: _____
Output Voltage: _____
Battery Reserve Time: _____

1.0 SAFETY PRECAUTIONS

Read this manual thoroughly, paying special attention to the sections that apply to you, before working with the UPS. Retain this section for use by installing personnel.

Under typical operation and with all UPS doors closed, only normal safety precautions are necessary. The area around the UPS system should be kept free from puddles of water, excess moisture, or debris.

Special safety precautions are required for procedures involving handling, installation, and maintenance of the UPS system or the battery. Observe all safety precautions in this manual before handling or installing the UPS system. Observe all safety precautions in the **Operation and Maintenance Manual**, before as well as during performance of all maintenance procedures. Observe all battery safety precautions before working on or near the battery.

This equipment contains several circuits that are energized with high voltage. Only test equipment designated for troubleshooting should be used. This is particularly true for oscilloscopes. Always check with an AC and DC voltmeter to ensure safety before making contact or using tools. Even when the power is turned Off, dangerously high potentials may exist at the capacitor banks and at the batteries.

ONLY qualified service personnel should perform maintenance on the UPS system. When performing maintenance with any part of the equipment under power, service personnel and test equipment should be standing on rubber mats. The service personnel should wear insulating shoes for isolation from direct contact with the floor (earth ground).

Unless all power is removed from the equipment, one person should never work alone. A second person should be standing by to assist and summon help in case an accident should occur.

Three types of messages are used throughout the manual to stress important text. Carefully read the text below each Warning, Caution, and Note and use professional skills and prudent care when performing the actions described by that text.

A **Warning** signals the presence of a possible serious, life-threatening condition. For example:



WARNING

LETHAL VOLTAGES MAY BE PRESENT WITHIN THIS UNIT EVEN WHEN IT IS APPARENTLY NOT OPERATING. OBSERVE ALL CAUTIONS AND WARNINGS IN THIS MANUAL. FAILURE TO DO SO COULD RESULT IN SERIOUS INJURY OR DEATH. DO NOT WORK ON OR OPERATE THIS EQUIPMENT UNLESS YOU ARE FULLY QUALIFIED TO DO SO!! NEVER WORK ALONE.

A **Caution** indicates a condition that could seriously damage equipment and possibly injure personnel. For example:



CAUTION

Extreme care is necessary when removing shoring braces. Do not strike the cabinet with hammers or other tools.

A **Note** emphasizes important text. If the note is not followed, equipment could be damaged or may not operate properly. For example:



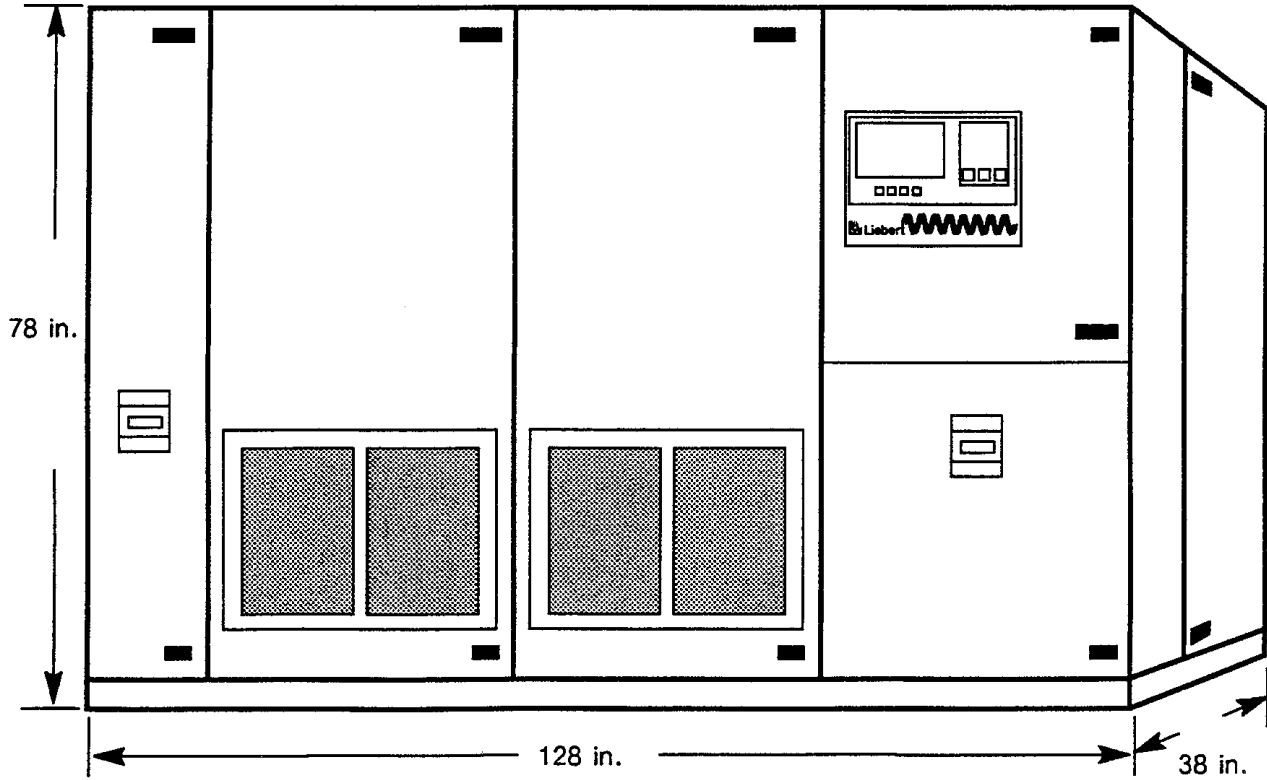
NOTE

If the UPS system has a blown fuse, the cause should be determined before you replace the fuse. Contact Liebert Customer Service and Support.



WARNING
LOCATE CENTER OF GRAVITY SYMBOLS 
AND DETERMINE UNIT WEIGHT
BEFORE HANDLING CABINET.

Figure 1 Multi-Module 338 kVA UPS



Each UPS module is shipped as two or three separate cabinets for easier handling.
Refer to the Shipping Split Detail drawing for dimensions and weights of your units.

2.0 INSTALLATION CONSIDERATIONS

Install your Series 600 UPS in accordance with the submittal drawing package and the following procedures.

A Liebert authorized representative must perform the initial system check-out and start-up to ensure proper system operation. Equipment warranties will be voided unless system start-up is performed by a Liebert authorized representative. Contact your local Liebert sales representative or Liebert Customer Service and Support at **1-800-543-2378** to arrange for system start-up.



CAUTION

Read this manual thoroughly before attempting to wire or operate the unit. Improper installation is the most significant cause of UPS start-up problems.

Do not install this equipment near gas or electric heaters. It is preferable to install the UPS in a restricted location to prevent access by unauthorized personnel.

Proper planning will speed unloading, location, and connection of the UPS. **Refer to Figure 4 through Figure 68 and Appendix A - Series 600 UPS Site Planning Data.**

Use the shortest output distribution cable runs possible, consistent with logical equipment arrangements and with allowances for future additions if planned.

Recommended ambient operating temperature is 25°C (77°F). Relative humidity must be less than 95%, non-condensing. Note that room ventilation is necessary, but air conditioning may not be required. Maximum ambient operating temperature is 40°C (104°F). The batteries should not exceed 25°C (77°F). At elevations above 4,000 feet (1219 meters) derating may be required (consult your Liebert sales representative).

1. Even though your Liebert UPS unit is at least 91% efficient, the heat output is substantial. For more specific information, see **Appendix A - Series 600 UPS Site Planning Data**. Be sure environmental conditioning systems can accommodate this BTU load, even during utility outages.
2. The routing (inside the facility) to the installation site, as well as the floor at the final equipment location, must be capable of supporting the cabinet weight and the weight of any moving equipment. The modules weigh between 8300 and 17400 pounds. Refer to **Appendix A - Series 600 UPS Site Planning Data**.
3. Plan the routing to ensure that the unit can move through all aisleways, doorways, and around corners without risking damage.



CAUTION

Observe all battery safety precautions when working on or near the battery.

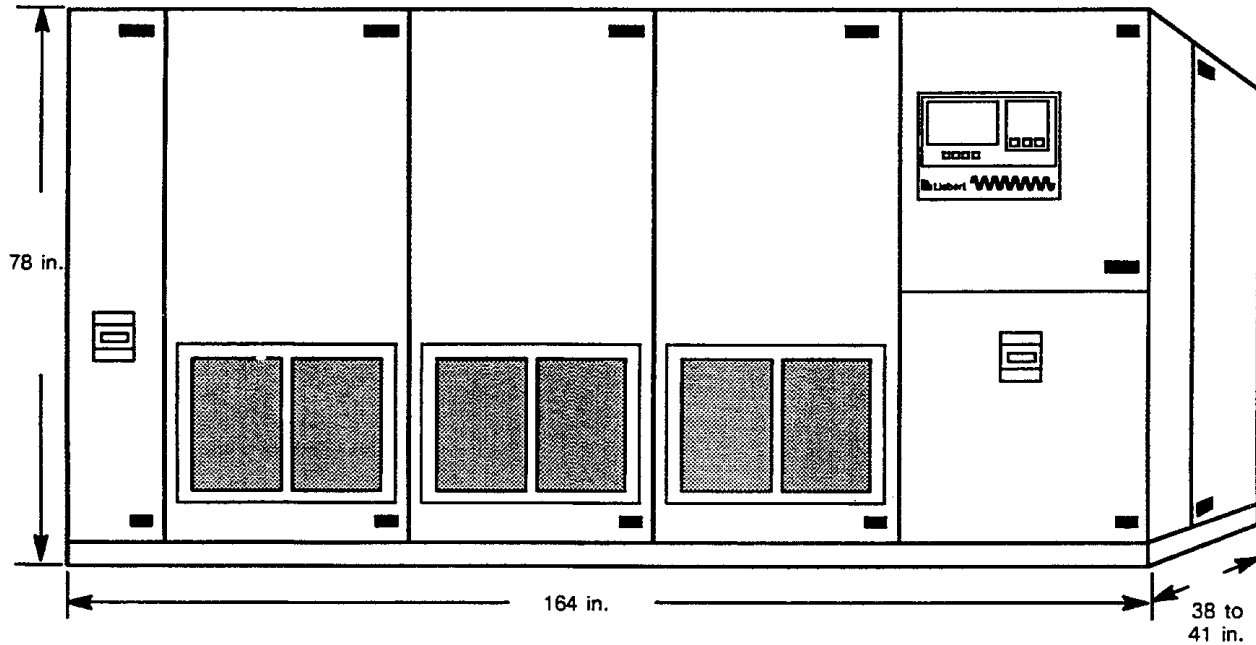


WARNING

**LOCATE CENTER OF GRAVITY SYMBOLS
AND DETERMINE UNIT WEIGHT
BEFORE HANDLING CABINET.**



Figure 2 Multi-Module 400 to 1000 kVA UPS



Cabinet depth of 400 and 500 kVA modules is 38 inches.
Cabinet depth of 625 and 750 (HL) kVA modules is 41 inches.

Refer to drawings for 208 VAC dimensions (338 to 500 kVA)
and for 750 (LL) and 1000 kVA modules (not shown).

Each UPS module is shipped as two or three separate cabinets for easier handling.
Refer to the Shipping Split Detail drawing for dimensions and weights of your units.

3.0 UNLOADING AND HANDLING

The UPS module is shipped as separate cabinets to allow easy handling at the site. Because the weight distribution in the cabinets is uneven, use extreme care during handling and transport.



WARNING

ONLY QUALIFIED PERSONNEL SHOULD HANDLE THIS EQUIPMENT. EXERCISE EXTREME CARE WHEN HANDLING UPS CABINETS TO AVOID EQUIPMENT DAMAGE OR INJURY TO PERSONNEL. THE UPS MODULE WEIGHT RANGES FROM 8300 POUNDS TO 17400 POUNDS.

LOCATE CENTER OF GRAVITY SYMBOLS BEFORE HANDLING EACH CABINET. TEST LIFT AND BALANCE THE CABINET BEFORE TRANSPORTING. MAINTAIN MINIMUM TILT FROM VERTICAL AT ALL TIMES.

MODULES AND SYSTEM CONTROL CABINETS (SCC'S) HAVE HOLES INTENDED FOR RIGGING BARS OR CHAINS. PREVENT CHAINS OR CABLES FROM CONTACTING CABINET BY USING SPREADER BAR AND ADEQUATE PADDING.

MODULES ARE SUPPLIED WITH BOLT-ON BRACKETS FOR USE WITH FORKLIFT. RECTANGULAR HOLES ARE PROVIDED FOR USE WITH ROL-A-LIFTS.

To reduce the possibility of shipping damage, cabinets are shored with 2x4 bracing, secured with screw-type nails. This shoring must be carefully removed prior to unloading.



CAUTION

Extreme care is necessary when removing shoring braces. Do not strike cabinet with hammers or other tools.

4.0 INSPECTIONS

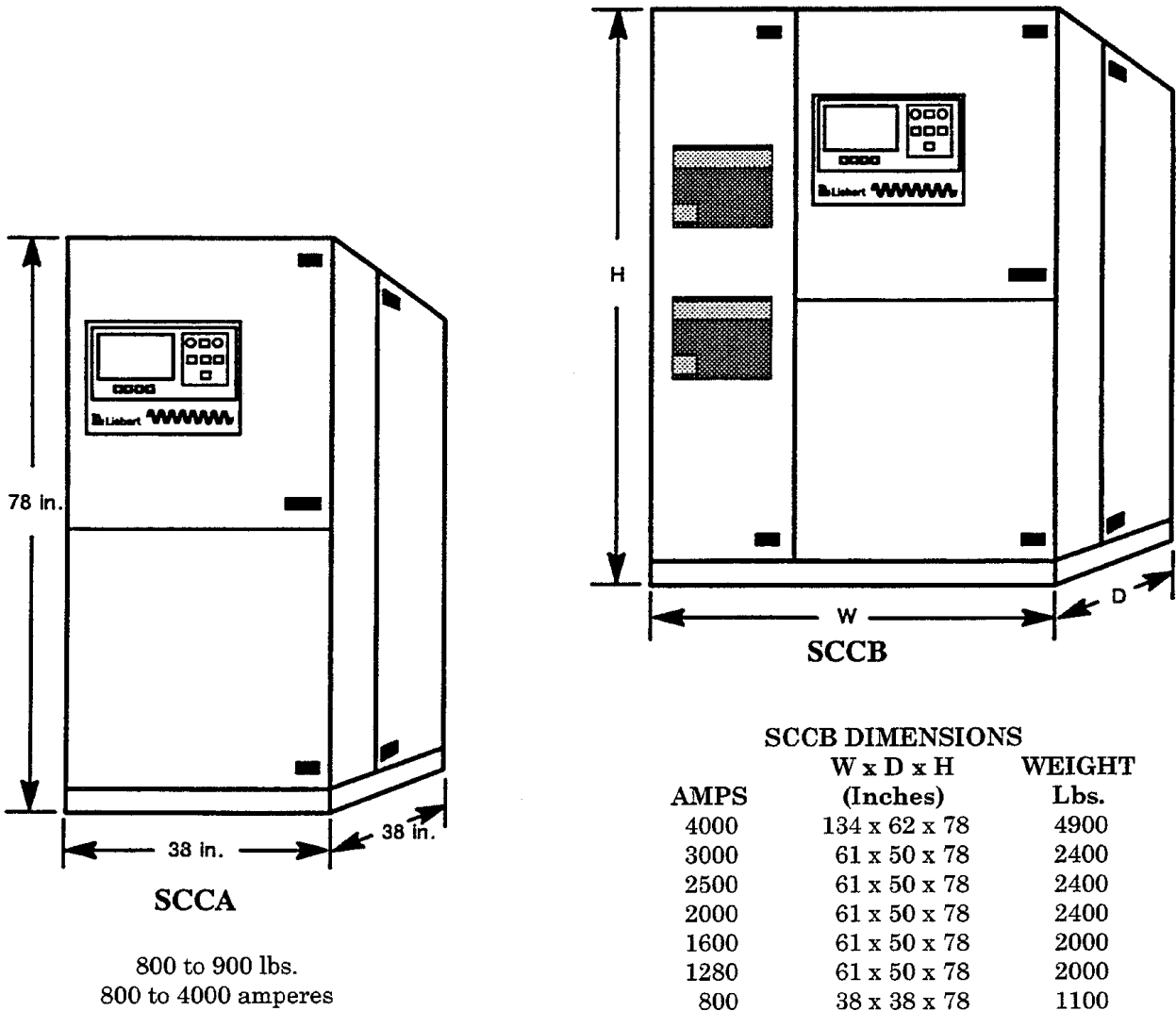
4.1 External Inspections

1. While the UPS system is still on the truck, inspect the equipment and shipping container(s) for any signs of damage or mishandling. Do not attempt to install the system if damage is apparent. If any damage is noted, file a damage claim with the shipping agency within 24 hours and contact Liebert Customer Service and Support at 1-800-543-2378 to inform them of the damage claim and the condition of the equipment.
2. Locate the bag containing the keys for the front access door. The bag is attached to the cabinet.
3. Compare the contents of the shipment with the bill of lading. Report any missing items to the carrier and to Liebert Customer Service and Support immediately.
4. Check the nameplate on the cabinets to verify that the model numbers correspond with the one specified. Record the model numbers and serial numbers in the front of this installation manual. A record of this information is necessary should servicing become required.

4.2 Internal Inspections

1. Verify that all items have been received.
2. If spare parts were ordered, verify arrival.
3. Open doors and remove cabinet panels to check for shipping damage to internal components.
4. Check for loose connections or unsecured components in the cabinet(s).
5. Check for installation of circuit breaker line safety shields. There should be no exposed circuit breaker terminals when the cabinet doors are opened.
6. Check for any unsafe condition that may be a potential safety hazard.
7. UPS modules are shipped with internally mounted shipping brackets. The shipping brackets (painted orange) must be removed from the rear (remove rear panels).

Figure 3 System Control Cabinets



TYPES OF SYSTEM CONTROL CABINETS (SCC)

- SCCA** A stand **alone** cabinet containing system control logic for up to six UPS modules, static bypass switch, manually operated disconnects for static bypass switch, but no motor operated system circuit breakers.
- SCCB** A stand alone cabinet containing all of the above plus 2 motor operated system circuit **breakers**.
- SCCC** An integrated configuration (like SCCI) with the static bypass switch rated for **continuous** duty.
- SCCI** System control logic and static bypass switch are **integrated** into a switchboard cabinet manufactured by others, which also includes the system circuit breakers.
- SCCP** A stand alone cabinet similar to SCCB except smaller in width (38 in.) and designed for two UPS modules (a **pair**). Current range is 240 to 2000 amperes. Weight ranges from 1000 to 1400 pounds.

5.0 EQUIPMENT LOCATION

1. Handle cabinets in accordance with **WARNINGS** in **3.0 - Unloading and Handling**. Use a suitable material handling device to move each cabinet to its final location. **Exercise extreme care because of the uneven weight distribution.**
2. Carefully lower the cabinets to the floor and position them for cabinet interconnection.
3. Verify that the UPS system is installed in a clean, cool and dry location.
4. Installation and serviceability will be easier if adequate access is provided on all sides of the equipment, but only access to the front and right side is required.
 - a. Verify that there is adequate clearance to open cabinet doors. See drawings and local codes (4 feet is recommended).
 - b. Verify that there is adequate area in front of circuit breakers to perform maintenance. Check installation drawings for location of breakers. Check with local codes.
 - c. Verify that there is adequate clearance above all cabinets to allow exhaust air to flow without restriction (2 feet minimum, unobstructed).
5. Connect the cabinets, internal cables, and bus bars. Refer to Shipping Split Details (**Figure 33** to **Figure 41**) and other drawings.

6.0 BATTERIES

6.1 Battery Safety Precautions

Installation and servicing of batteries should be performed or supervised by personnel knowledgeable of batteries and the required precautions. Keep unauthorized personnel away from batteries.

When replacing batteries, use the same number and type of batteries.



CAUTION

Lead-acid batteries contain hazardous materials. Batteries must be handled, transported, and recycled or discarded in accordance with federal, state, and local regulations. Because lead is a toxic substance, lead-acid batteries should be recycled rather than discarded.

Do not open or mutilate the battery or batteries. Released electrolyte is harmful to the skin and eyes. It may be toxic. Do not dispose of battery or batteries in a fire. The battery may explode.

A battery can present a risk of electrical shock and high short circuit current. The following precautions should be observed when working on batteries:

- 1. Remove watches, rings, or other metal objects.**
- 2. Use tools with insulated handles.**
- 3. Wear rubber gloves and boots.**
- 4. Do not lay tools or metal parts on top of batteries.**
- 5. Disconnect charging source prior to connecting or disconnecting battery terminals.**
- 6. Determine if battery is inadvertently grounded. If inadvertently grounded, remove source of ground. Contact with any part of a grounded battery can result in electrical shock. The likelihood of such shock will be reduced if such grounds are removed during installation and maintenance.**

Lead-acid batteries can present a risk of fire because they generate hydrogen gas. The following procedures should be followed:

- 1. DO NOT SMOKE when near batteries.**
- 2. DO NOT cause flame or spark in battery area.**
- 3. Discharge static electricity from body before touching batteries by first touching a grounded metal surface.**

Battery Safety Precautions in French Per CSA Requirements

Instructions Importantes Concernant La Sécurité

Conserver Ces Instructions



ADVERTISSEMENT

DES PIÈCES SOUS ALIMENTATION SERONT LAISSÉES SANS PROTECTION DURANT CES PROCÉDURES D'ENTRETIEN. UN PERSONNEL QUALIFIÉ EST REQUIS POUR EFFECTUER CES TRAVAUX.

LES FUSIBLES A C.C. DE LA BATTERIE D'ACCUMULATEURS OPÈRENT EN TOUT TEMPS A LA TENSION NOMINALE. LA PRÉSENCE D'UN FUSIBLE A C.C. BRÛLÉ INDIQUE UN PROBLÈME SÉRIEUX. LE REMPLACEMENT DE CE FUSIBLE, SANS AVOIR DÉTERMINÉ LES RAISONS DE LA DÉFECTUOSITÉ, PEUT ENTRAÎNER DES BLESSURES OU DES DOMMAGES SÉRIEUX À L'ÉQUIPEMENT. POUR ASSISTANCE, APPELER LE DÉPARTEMENT DE SERVICE À LA CLIENTÈLE DE LIEBERT.



DANGER

Les accumulateurs plomb-acide contiennent de la matière comportant un certain risque. Les accumulateurs doivent être manipulés, transportés et recyclés ou éliminés en accord avec les lois fédérales, provinciales et locales. Parce que le plomb est une substance toxique, les accumulateurs plomb-acide devraient être recyclés plutôt qu'éliminés.

Il ne faut pas brûler le ou les accumulateurs. L'accumulateur pourrait alors exploser.

Il ne faut pas ouvrir ou endommager le ou les accumulateurs. L'électrolyte qui pourrait s'en échapper est dommageable pour la peau et les yeux.

Un accumulateur représente un risque de choc électrique et de haut courant de court-circuit. Lorsque des accumulateurs sont manipulés, les mesures préventives suivantes devraient être observées:

1. Retirer toutes montres, bagues ou autres objets métalliques.
2. Utiliser des outils avec manchon isolé.
3. Porter des gants et des bottes de caoutchouc.
4. Ne pas déposer les outils ou les pièces métalliques sur le dessus des accumulateurs.
5. Interrompre la source de charge avant de raccorder ou de débrancher les bornes de la batterie d'accumulateurs.
6. Déterminer si l'accumulateur est mis à la terre par erreur. Si oui, défaire cette mise à la terre. Tout contact avec un accumulateur mis à la terre peut se traduire en un choc électrique. La possibilité de tels chocs sera réduite si de telles mises à la terre sont débranchées pour la durée de l'installation ou de l'entretien.

Les accumulateurs plomb-acide présentent un risque d'incendie parce qu'ils génèrent des gaz à l'hydrogène. Les procédures suivantes devront être respectées.

1. **NE PAS FUMER** lorsque près des accumulateurs.
2. **NE PAS** produire de flammes ou d'étincelles près des accumulateurs.
3. Décharger toute électricité statique présente sur votre corps avant de toucher un accumulateur en touchant d'abord une surface métallique mise à la terre.



DANGER

L'électrolyte est un acide sulfurique dilué qui est dangereux au contact de la peau et des yeux. Ce produit est corrosif et aussi conducteur électrique. Les procédures suivantes devront être observées:

1. Porter toujours des vêtements protecteurs ainsi que des lunettes de protection pour les yeux.
2. Si l'électrolyte entre en contact avec la peau, nettoyer immédiatement en rinçant avec de l'eau.
3. Si l'électrolyte entre en contact avec les yeux, arroser immédiatement et généreusement avec de l'eau. Demander pour de l'aide médicale.
4. Lorsque l'électrolyte est renversée, la surface affectée devrait être nettoyée en utilisant un agent neutralisant adéquat. Une pratique courante est d'utiliser un mélange d'approximativement une livre (500 grammes) de bicarbonate de soude dans approximativement un gallon (4 litres) d'eau. Le mélange de bicarbonate de soude devra être ajouté jusqu'à ce qu'il n'y ait plus apparence de réaction (mousse). Le liquide résiduel devra être nettoyé à l'eau et la surface concernée devra être asséchée.

6.2 Battery Installation

A remote battery disconnect switch with overcurrent protection is required per the National Electrical Code. A disconnecting means (per UL1778) such as a module battery disconnect or battery isolation switch should be provided for each parallel string of batteries. Refer to **Figure 66** and **Figure 67**. Contact your Liebert sales representative regarding this option.

1. Install battery racks and batteries per manufacturer's installation and maintenance instructions.
2. Verify battery area has adequate ventilation and battery operating temperature complies with manufacturer's specification.

If you have any questions concerning batteries, battery racks, or accessories, contact Liebert Customer Service and Support at **1-800-543-2378**.

7.0 WIRING CONSIDERATIONS



WARNING

ALL POWER CONNECTIONS MUST BE COMPLETED BY A LICENSED ELECTRICIAN THAT IS EXPERIENCED IN WIRING THIS TYPE OF EQUIPMENT. WIRING MUST BE INSTALLED IN ACCORDANCE WITH ALL APPLICABLE NATIONAL AND LOCAL ELECTRICAL CODES. IMPROPER WIRING MAY CAUSE DAMAGE TO THE EQUIPMENT OR INJURY TO PERSONNEL.



WARNING

VERIFY THAT ALL INCOMING HIGH AND LOW VOLTAGE POWER CIRCUITS ARE DE-ENERGIZED AND LOCKED OUT BEFORE INSTALLING CABLES OR MAKING ANY ELECTRICAL CONNECTIONS.

Refer to **Appendix A - Series 600 UPS Site Planning Data** and installation drawings (**Figure 4** through **Figure 68**). Determine AC currents for your system (kVA, voltage, and optional input filter). Also refer to equipment nameplate for the model number, rating, and voltage. Refer to **Table 1** and **Table 2** for wire termination data.



NOTE

*Use 75°C copper wire. Select wire size based on the ampacities in **Table 3** of this manual, a reprint of Table 310-16 and associated notes of the National Electrical Code (NFPA 70).*



CAUTION

The weight of power cables must be adequately supported to avoid stress on bus bars and lugs. In addition to weight support, the following restraining method is recommended to control cable movement during external fault conditions: Wrap line cables together at 6 inches and 12 inches from the terminals with 5 wraps of 3/8 inch nylon rope or equivalent (tensile strength of 2000 pounds). Support remainder of cable with 5 wraps every 6 inches or 1 wrap every 1 inch.

Abbreviations for Circuit Breakers	
BFB	Bypass Feeder Breaker
BIB	Bypass Input Breaker
CB1	Module Input Breaker
CB2	Module Output Breaker
MBB	Maintenance Bypass Breaker
MBD	Module Battery Disconnect
MBFB	Maintenance Bypass Feeder Breaker
MIB	Maintenance Isolation Breaker
RIB	Rectifier Input Breaker
SBB	System Bypass Breaker
SBS	Static Bypass Switch

Figure 4 Typical Multi-Module Configurations

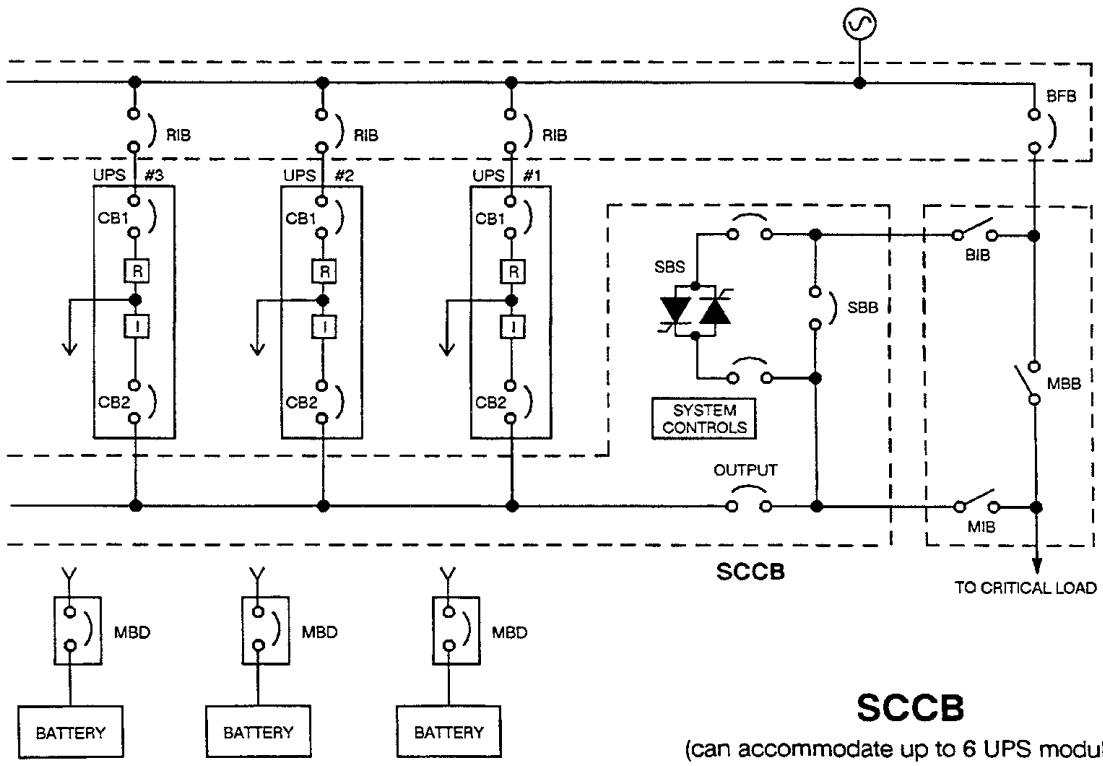
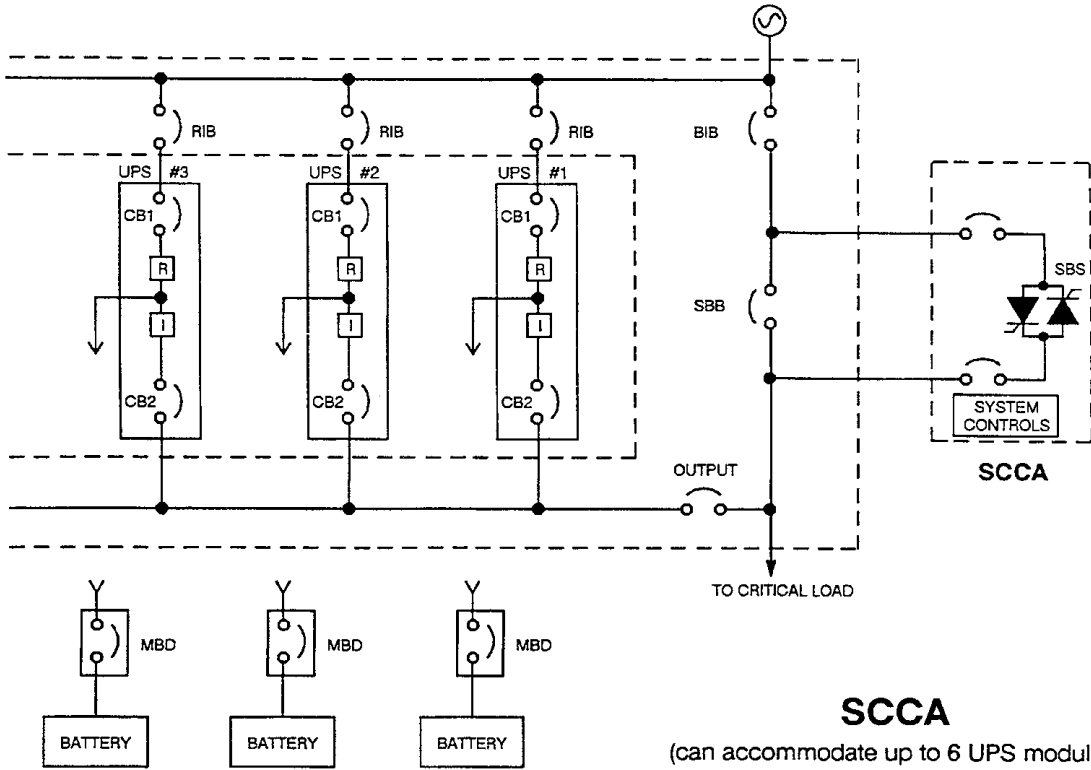
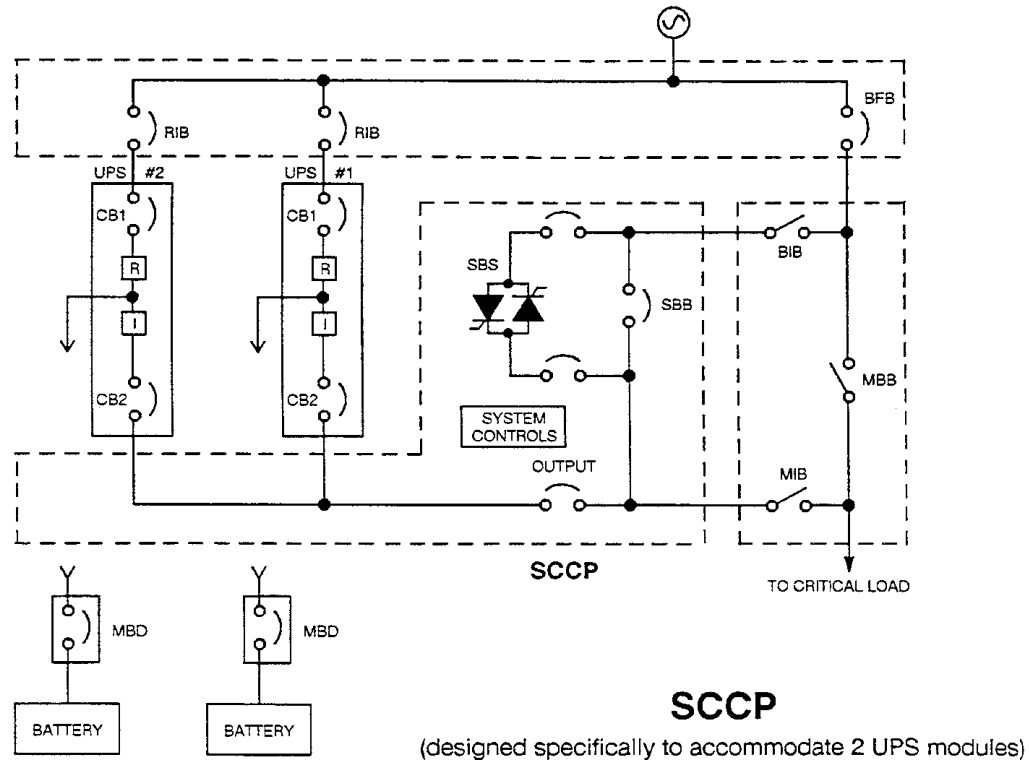
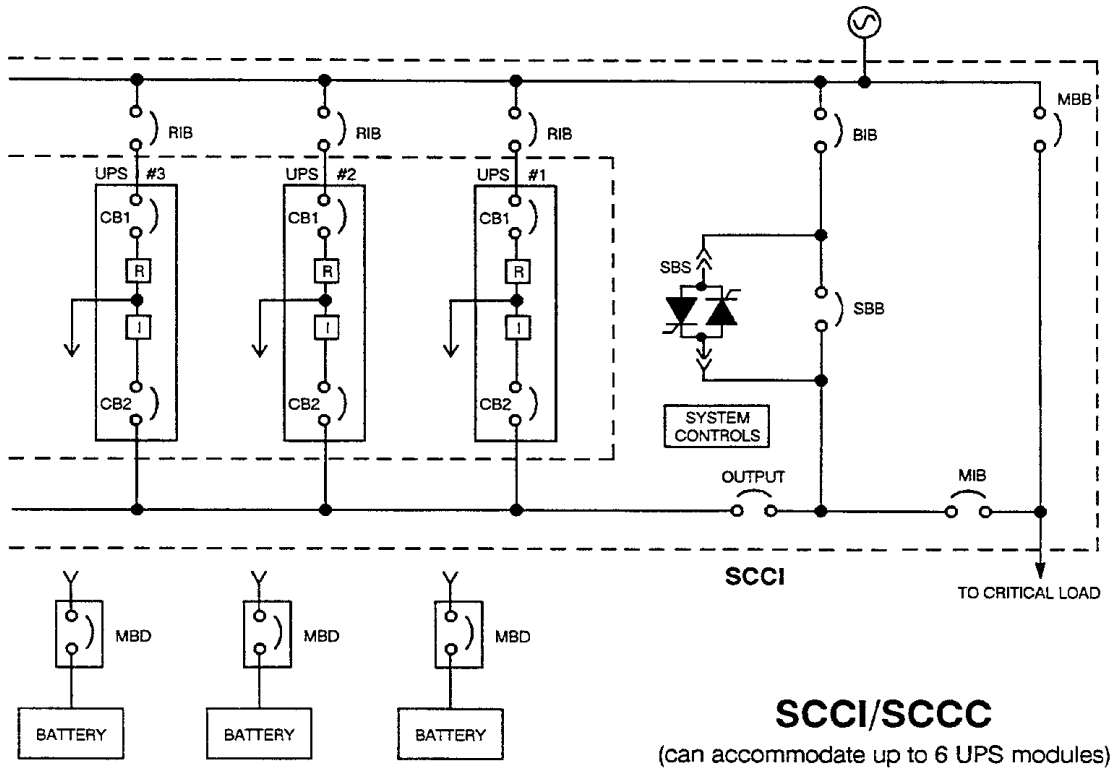


Figure 4 Typical Multi-Module Configurations (continued)



7.1 Power and Control Wiring

1. Power wiring must be run in individual, separate conduits or cable trays. Control wiring must be stranded and run in individual separate steel conduits.



CAUTION

Power and control wiring must be separated!

2. Observe local, state and national electrical codes. Verify utility power and its overcurrent protection rating will accommodate the UPS input rating, including battery recharging.
3. A safety ground wire must be run from building ground to ground point in the UPS Module Cabinet and the SCC. The grounding conductor shall comply with the following conditions of installation:
 - a. An insulated grounding conductor that is green, with or without one or more yellow stripes, is to be installed as part of the branch circuit that supplies the unit or system.
 - b. The grounding conductor described above is to be grounded to earth at the service equipment or, if supplied by a separately derived system, at the supply transformer or motor-generator set.
 - c. The attachment-plug receptacles in the vicinity of the unit or system are all to be of a grounding type, and the grounding conductors serving these receptacles are to be connected to earth ground at the service equipment.
4. Observe clockwise phase rotation of all power wiring. Phase A leads Phase B leads Phase C. A qualified electrician should check the phase rotation.
5. NEC Class I wiring methods are required for control and communication Class 2 circuits.

7.2 Battery Wiring

Power wiring to the batteries connects positive, negative, and ground power cables from the batteries to the associated UPS. Connection of the UPS to the batteries serves to both charge and discharge the batteries (when needed). The battery disconnect (circuit breaker) requires a control cable. Refer to **Figure 66** and **Figure 67**.



CAUTION

Be sure polarity is correct when wiring the batteries to the connected equipment (positive to positive; negative to negative). If polarity is not correct, fuse failures or equipment damage can result.

Call Liebert Customer Service and Support to schedule installation check-out and start-up.



NOTE

Inspection of the battery installation is a service that can be provided by Liebert. A Battery Specialist can perform a detailed inspection of the entire battery system to ensure it meets current IEEE standards. This inspection service is recommended because batteries are a very critical part of the UPS system.

8.0 WIRING CONNECTIONS



WARNING

VERIFY THAT ALL INCOMING HIGH AND LOW VOLTAGE POWER CIRCUITS ARE DE-ENERGIZED AND LOCKED OUT BEFORE INSTALLING CABLES OR MAKING ELECTRICAL CONNECTIONS.

ALL POWER CONNECTIONS MUST BE COMPLETED BY A LICENSED ELECTRICIAN EXPERIENCED IN WIRING UPS EQUIPMENT, AND IN ACCORDANCE WITH ALL APPLICABLE NATIONAL AND LOCAL ELECTRICAL CODES.

IMPROPER WIRING MAY CAUSE DAMAGE TO THE UPS OR INJURY TO PERSONNEL.



CAUTION

All shielded cables, non-shielded cables, non-shielded control wires, non-shielded battery breaker control wires, and non-shielded remote control wires must be housed in individual, separate, steel conduits. Placing multiple cables in the same conduit with other control or power wiring may cause system failure.

Refer to the drawings in this manual and any other drawings provided by Liebert for this installation. Make all of the following connections:

1. AC power cables from input power source circuit breaker (RIB) to UPS Module Input. Observe phase rotation.
2. AC power cables from bypass power source circuit breaker (BIB) to UPS system bypass input at System Control Cabinet (SCC). Observe phase rotation.
3. AC power cables from UPS Module Outputs to SCC or to switchgear for critical load bus. Observe phase rotation.
4. Each UPS Module Output Neutral to SCC or to switchgear for critical load bus.
5. The UPS System Output Neutral is connected to one common point and solidly grounded per requirements of the National Electrical Code. The ground connection inside the UPS SCC cabinet may be required by the power wiring configuration at your site.



CAUTION

UPS bypass and system output neutral must be connected to only one common point in the UPS system. This neutral line must be grounded at the source.

6. DC power cables (and ground) from battery to Module Battery Disconnect (MBD) circuit breaker, and then to UPS Module DC bus. Observe polarity. DC power cables should be installed in conduit with conductors in matched pairs (positive and negative).
7. Module Battery Disconnect control wiring to UPS Module. Module Battery Disconnect control wiring must be housed in individual separate steel conduit. Do not run in power circuit conduit.
8. Control wiring from System Control Cabinet (SCC) to UPS modules. Wiring must be run in individual separate steel conduit.
9. Power and control connections required for the Maintenance Bypass Switchboard.
10. Power connections from SCC to critical load bus. Observe phase rotation.
11. Control wiring to Remote Monitor Panel, if used. Selected alarm messages are also available for customer use through a set of contacts on a separate terminal board. Wiring must be run in individual separate steel conduit.
12. Emergency Power Off control wiring (to SCC) must be run in separate steel conduit.
13. Communications wiring (to SCC) for terminals, site monitoring, or modem must be run in separate steel conduit.
14. Any additional special wiring required at your site.

9.0 WIRING INSPECTION

1. Verify all power connections are tight.
2. Verify all control wire terminations are tight.
3. Verify all power wires and connections have proper spacing between exposed surfaces, phase-to-phase and phase-to-ground.
4. Verify that all control wires are run in individual, separate, steel conduit.

Table 1 Power Wiring Terminals - Factory Supplied

Connection Type					
UPS Module Rating kVA	AC Input	AC Output	Battery	Neutral	Ground
338 - 1000	Lugs on circuit breakers, or bus bars (for field supplied lugs). Refer to installation drawings.		Bus bars for connecting hardware (1/2" on 1-3/4" centers) are provided. A field supplied lug is required.		
Use 75°C copper wire. Select wire size based on the ampacities in Table 310-16 (see Table 3 of this manual) and associated notes of the National Electrical Code (NFPA 70).					
Use commercially available solderless lugs for the wire size required for your application. Connect wire to the lug using tool and procedure specified by the lug manufacturer.					

Table 2 Torque Specifications

Nut and Bolt Combinations				
Bolt Shaft Size	Grade 2 Standard		Electrical Connections with Belleville Washers	
	Lb-in	N-m	Lb-in	N-m
1/4	53	6.0	46	5.2
5/16	107	12	60	6.8
3/8	192	22	95	11
1/2	428	48	256	29

Circuit Breakers With Compression Lugs (For Power Wiring)		
Current Rating	Lb-in	N-m
400 - 1200 Amps	300	34

Terminal Block Compression Lugs (For Control Wiring)		
AWG Wire Size or Range	Lb-in	N-m
#22 - #14	3.5 to 5.3	0.4 to 0.6

Use the values in this table unless the equipment is labeled with a different torque value.

Table 3 Table 310-16

Allowable Ampacities of Insulated Conductors Rated 0-2000 Volts, 60° to 90°C (140° to 194°F)¹

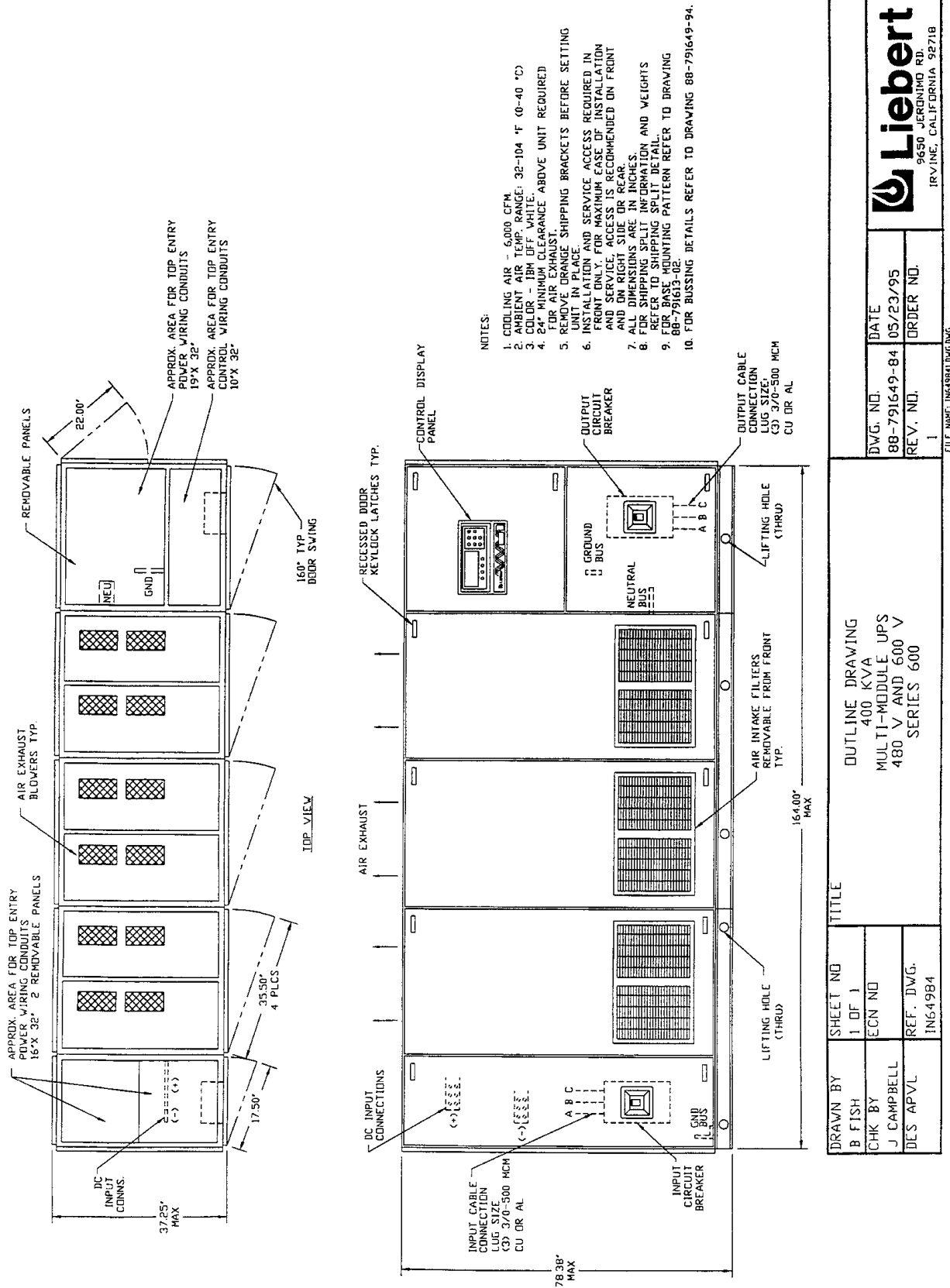
Not More than Three Conductors in Raceway or Cable or Earth (Directly Buried), based on Ambient Temperature of 30° (86°F)

Size	Temperature Rating of Conductor. See Table 310-13.						Size
	60°C (140°F)	75°C (167°F)	90°C (194°F)	60°C (140°F)	75°C (167°F)	90°C (194°F)	
	Types TW† UF†	Types FEPW+, RH,RHW†, THHW†, THW†, THWN†, XHHW†, USE†, ZW†	Types TBS, SA, SIS,FEP†, FEPB†,MI, RHH†, RHW-2 THHN†,THHW†, THW-2,THWN-2, USE-2, XHH, XHHW† XHHW-2,ZW-2	Types TW† UF†	Types RH†, RHW†, THHW†, THW†, THWN†, XHHW†, USE†	Types TBS, SA,SIS, THHN†, THHW†, THW-2, THWN-2, RHH†, RHW-2, USE-2, XHH, XHHW†, XHHW-2, ZW-2	
Copper			Aluminum or Copper-Clad Aluminum				
18	14
16	18
14	20†	20†	25†
12	25†	25†	30†	20†	20†	25†	12
10	30	35†	40†	25	30†	35†	10
8	40	50	55	30	40	45	8
6	55	65	75	40	50	60	6
4	70	85	95	55	65	75	4
3	85	100	110	65	75	85	3
2	95	115	130	75	90	100	2
1	110	130	150	85	100	115	1
1/0	125	150	170	100	120	135	1/0
2/0	145	175	195	115	135	150	2/0
3/0	165	200	225	130	155	175	3/0
4/0	195	230	260	150	180	205	4/0
250	215	255	290	170	205	230	250
300	240	285	320	190	230	255	300
350	260	310	350	210	250	280	350
400	280	335	380	225	270	305	400
500	320	380	430	260	310	350	500
600	355	420	475	285	340	385	600
700	385	460	520	310	375	420	700
750	400	475	535	320	385	435	750
800	410	490	555	330	395	450	800
900	435	520	585	355	425	480	900
1000	455	545	615	375	445	500	1000
1250	495	590	665	405	485	545	1250
1500	520	625	705	435	520	585	1500
1750	545	650	735	455	545	615	1750
2000	560	665	750	470	560	630	2000
Correction Factors							
Ambient Temp °C	For ambient temperatures other than 30°C (86°F), multiply the allowable ampacities shown above by the appropriate factor shown below.						Ambient Temp °F
21-25	1.08	1.05	1.04	1.08	1.05	1.04	70-77
26-30	1.00	1.00	1.00	1.00	1.00	1.00	78-86
31-35	.91	.94	.96	.91	.94	.96	87-95
36-40	.82	.88	.91	.82	.88	.91	96-104
41-45	.71	.82	.87	.71	.82	.87	105-113
46-50	.58	.75	.82	.58	.75	.82	114-122
51-55	.41	.67	.76	.41	.67	.76	123-131
56-6058	.7158	.71	132-140
61-7033	.5833	.58	141-158
71-804141	159-176

† Unless otherwise specifically permitted elsewhere in this Code, the overcurrent protection for conductor types marked with an obelisk (†) shall not exceed 15 amperes for No. 14, 20 amperes for No. 12, and 30 amperes for No. 10 copper; or 15 amperes for No. 12 and 25 amperes for No. 10 aluminum and copper-clad aluminum after any correction factors for ambient temperature and number of conductors have been applied.

¹ Reprinted with permission from NFPA 70-1993, the National Electrical Code®, Copyright 1996, National Fire Protection Association, Quincy, MA 02269. This reprinted material is not the complete and official position of the National Fire Protection Association, on the referenced subject which is represented only by the standard in its entirety.

Figure 6 Outline Drawing, 400 kVA

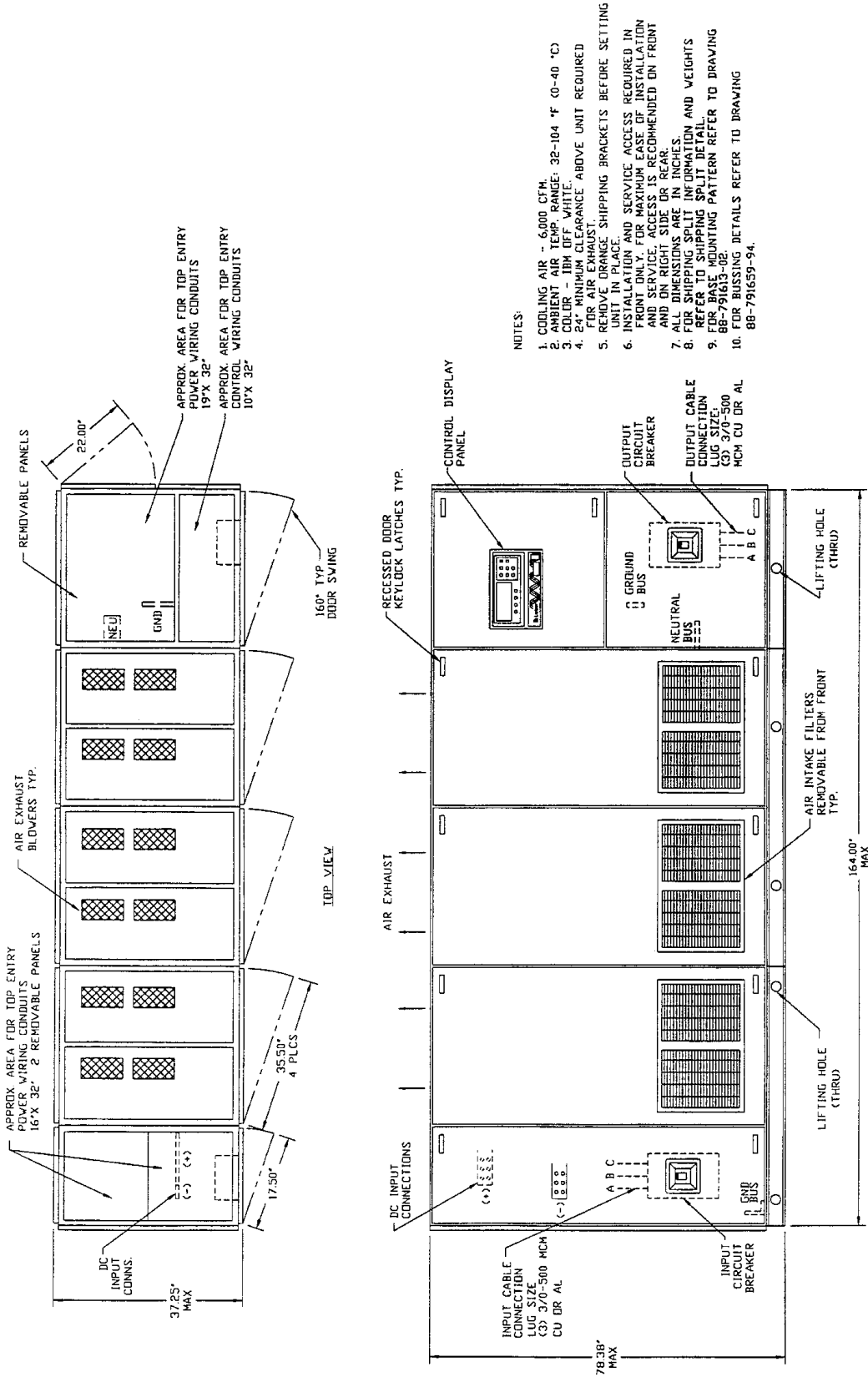


9650 JERONIMO RD.
IRVINE, CALIFORNIA 92718

DWG. NO.	DATE
88-791649-84	05/23/95
REV. NO.	ORDER NO.
1	

OUTLINE DRAWING	
400 KVA	
MULTI-MODULE UPS	
480 V AND 600 V	
SERIES 600	
DRAWN BY	SHEET NO
B FISH	1 OF 1
CHK BY	ECN NO
J CAMPBELL	
DES APVL	REF. DWG.
	IN64984

Figure 7 Outline Drawing, 500 kVA

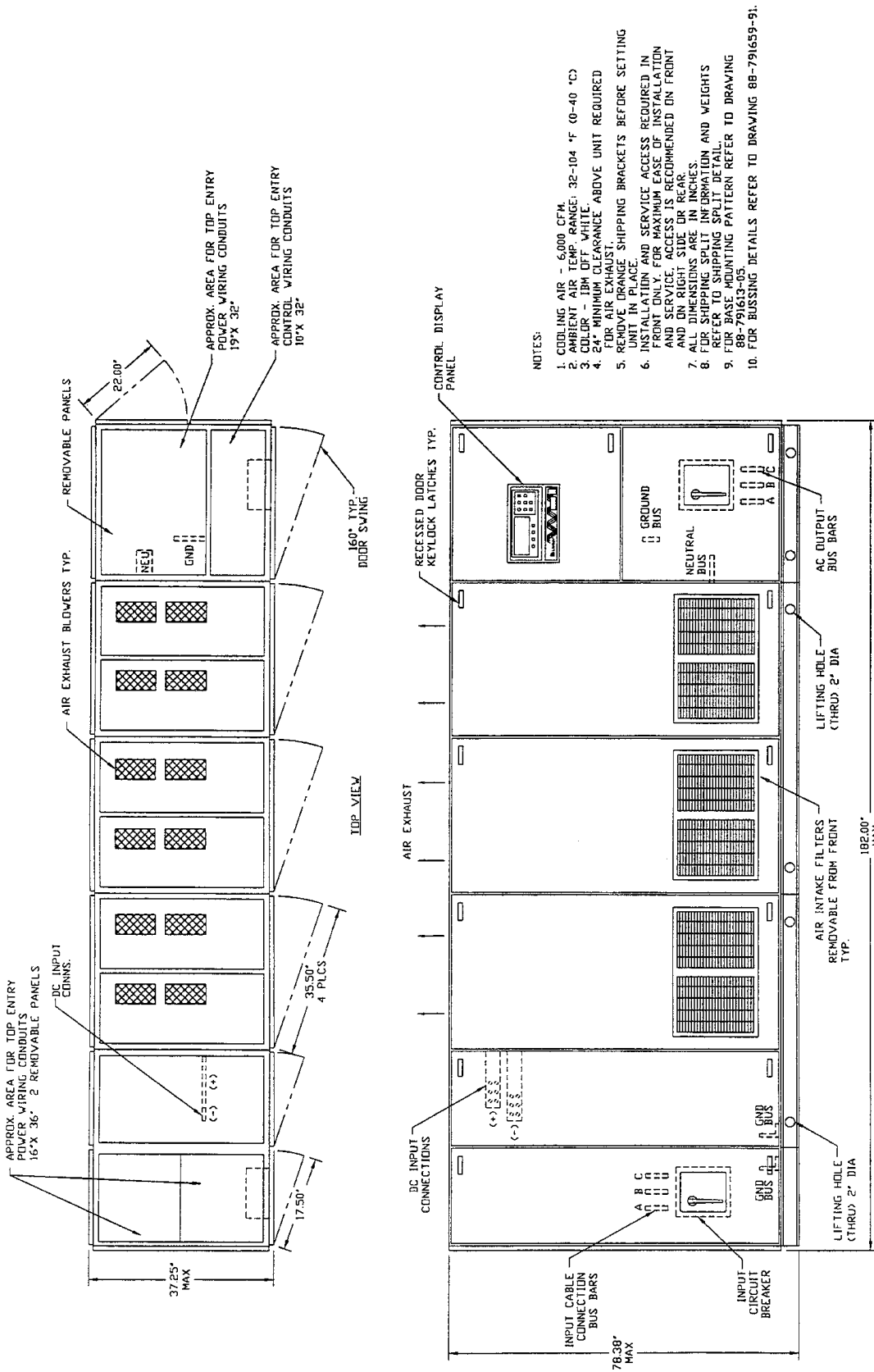


- NOTES:
1. COOLING AIR - 6,000 CFM.
 2. AMBIENT AIR TEMP. RANGE: 32-104 °F (0-40 °C)
 3. ALL DIMENSIONS ARE IN INCHES.
 4. 24" MINIMUM CLEARANCE ABOVE UNIT REQUIRED FOR AIR EXHAUST.
 5. REMOVE ORANGE SHIPPING BRACKETS BEFORE SETTING UNIT IN PLACE.
 6. INSTALLATION AND SERVICE ACCESS REQUIRED IN FRONT ONLY. FOR MAXIMUM EASE OF INSTALLATION AND SERVICE, ACCESS IS RECOMMENDED ON FRONT AND ON RIGHT SIDE OR REAR.
 7. ALL DIMENSIONS ARE IN INCHES.
 8. FOR SHIPPING, WEIGHT INFORMATION, AND WEIGHTS FOR BASE MOUNTING PATTERN REFER TO DRAWING 88-791613-02.
 9. FOR BASE MOUNTING PATTERN REFER TO DRAWING 88-791613-02.
 10. FOR BUSSING DETAILS REFER TO DRAWING 88-791659-94.

DWG. NO. 88-791659-84		DATE 05/30/95	
REV. NO. 1		ORDER NO.	
TITLE OUTLINE DRAWING 500 KVA MULTI-MODULE UPS 480 V AND 600 V SERIES 600			
DRAWN BY B FISH	SHEET NO 1 OF 1	TITLE	
CHK BY J CAMPBELL	ECN NO	TITLE	
DES APVL IN65984	REF DWG. IN65984	TITLE	



Figure 8 Outline Drawing, 500 kVA, 208 VAC



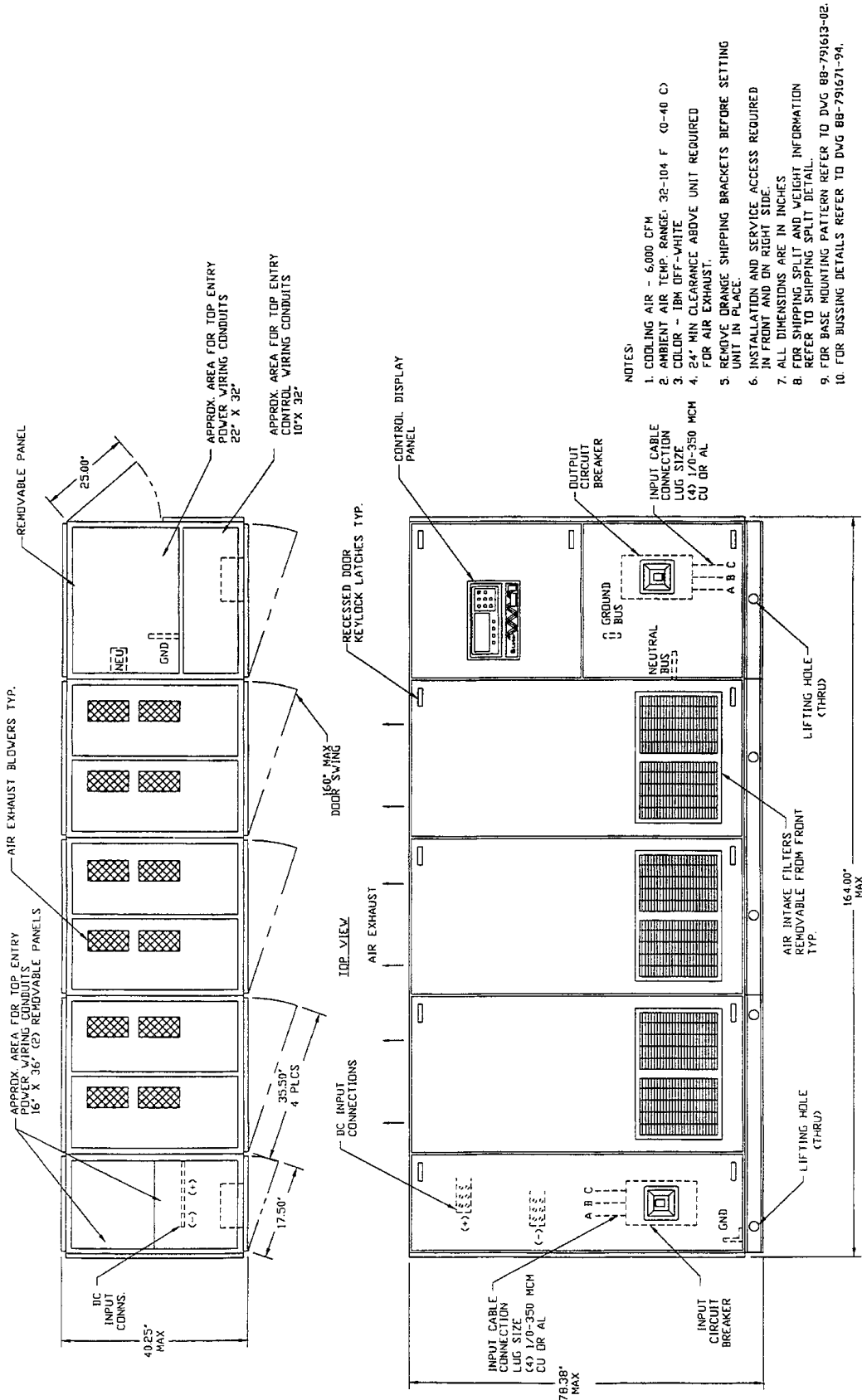
- NOTES:
1. COOLING AIR - 6,000 CFM.
 2. AMBIENT AIR TEMP. RANGE: 32-104 °F (0-40 °C)
 3. AIR FLOW RATE: 1000 CFM
 4. 24" MINIMUM CLEARANCE ABOVE UNIT REQUIRED FOR AIR EXHAUST
 5. REMOVE ORANGE SHIPPING BRACKETS BEFORE SETTING UNIT IN PLACE
 6. INSTALLATION AND SERVICE ACCESS REQUIRED IN FRONT ONLY. FOR MAXIMUM EASE OF INSTALLATION AND SERVICE, ACCESS IS RECOMMENDED ON FRONT AND ON RIGHT SIDE OR REAR.
 7. ALL DIMENSIONS ARE IN INCHES.
 8. FOR SHIPPING, SPLIT INFORMATION AND WEIGHTS REFER TO SHIPPING PATTERN REF ID DRAWING 88-791659-05
 9. FOR BUSSING DETAILS REFER TO DRAWING 88-791659-91.
 10. FOR BUSSING DETAILS REFER TO DRAWING 88-791659-91.

DRAWN BY B FISH		SHEET NO 1 DF 1		TITLE OUTLINE DRAWING 500 KVA MULTI-MODULE UPS 208 V INPUT - 208 / 120 V OUTPUT SERIES 600	
CHK BY J CAMPBELL		ECN NO		DWG. NO. 88-791659-81	
DES APVL		REF. DWG. IN65981		DATE 05/30/95	
				ORDER NO.	



FILE NAME: INS8BUILDG

Figure 9 Outline Drawing, 625 kVA

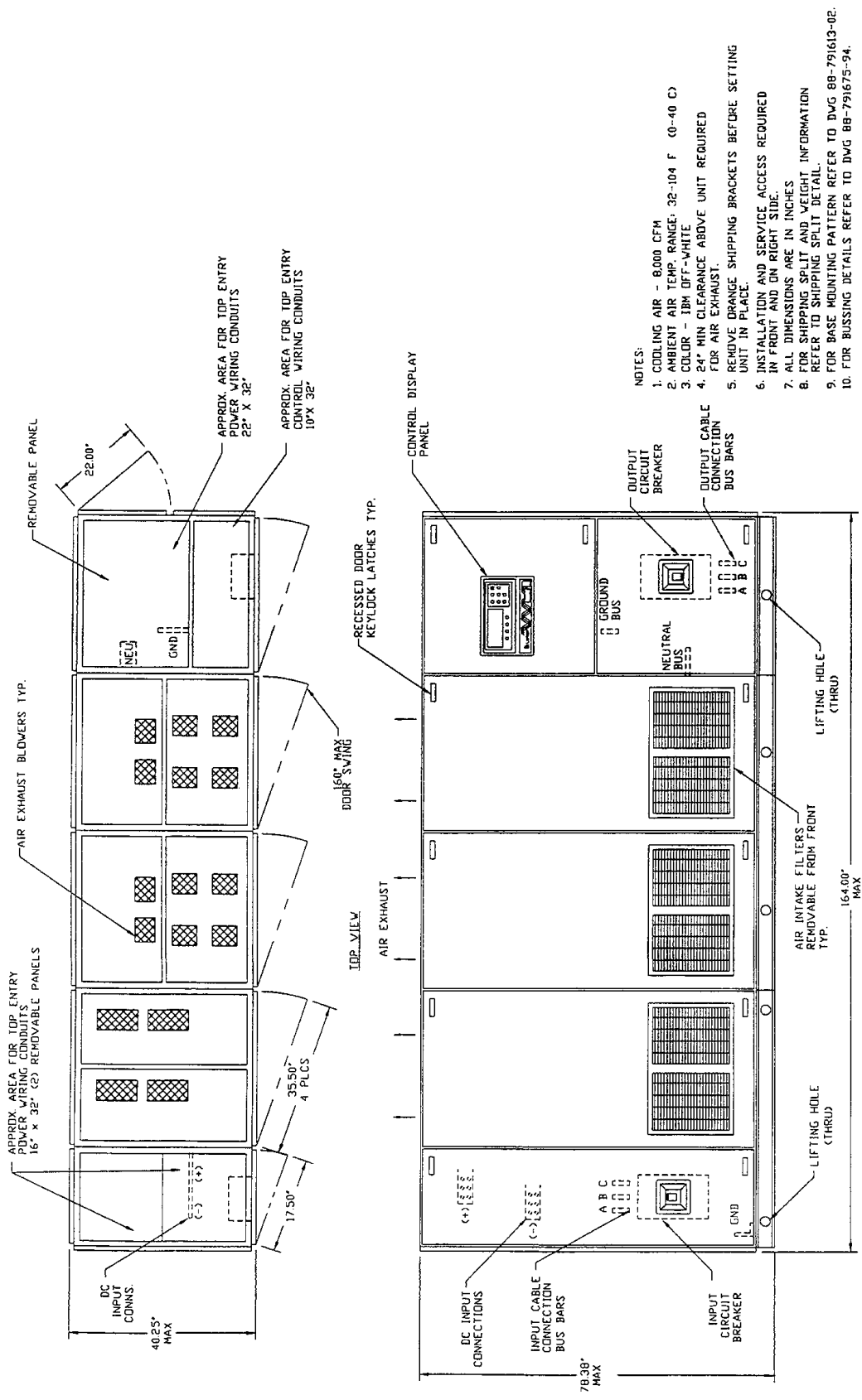


- NOTES:
1. COOLING AIR - 6,000 CFM
 2. AMBIENT AIR TEMP. RANGE: 32-104 F (0-40 C)
 3. COLOR - 1BM OFF-WHITE
 4. 24" MIN CLEARANCE ABOVE UNIT REQUIRED FOR AIR EXHAUST.
 5. REMOVE ORANGE SHIPPING BRACKETS BEFORE SETTING UNIT IN PLACE.
 6. INSTALLATION AND SERVICE ACCESS REQUIRED IN FRONT AND ON RIGHT SIDE.
 7. ALL DIMENSIONS ARE IN INCHES
 8. FOR SHIPPING SPLIT AND WEIGHT INFORMATION REFER TO SHIPPING PATTERN DETAIL.
 9. FOR BASE MOUNTING PATTERN REFER TO DWG 88-791613-02.
 10. FOR BUSSING DETAILS REFER TO DWG 88-791671-94.

DRAWN BY B FISH		SHEET NO 1 OF 1		TITLE OUTLINE DRAWING 625 KVA MULTI-MODULE UPS 480 V AND 600 V SERIES 600	
CHK BY J CAMPBELL		ECN NO		DWG. NO. 88-791671-84	
DES' APVL IN67184		REF. DWG.		DATE 05/31/95	
				ORDER NO.	



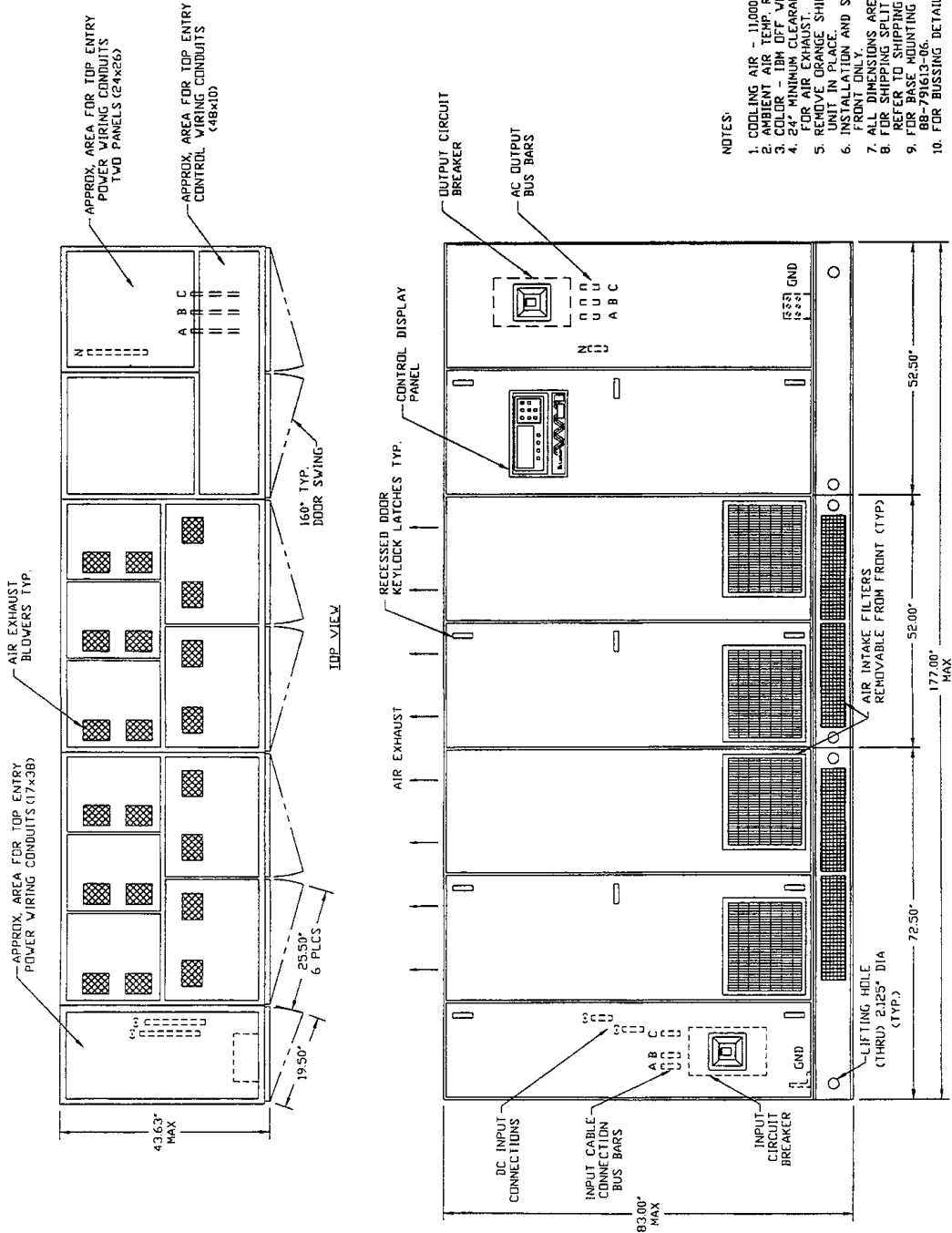
Figure 10 Outline Drawing, 750 kVA (High Link - 240 Cells)



DRAWN BY B FISH		SHEET NO 1 OF 1		TITLE OUTLINE DRAWING 750 KVA - 240 CELL MULTI-MODULE UPS 480 V AND 600 V SERIES 600	
CHK BY J CAMPBELL		ECN NO		DWG. NO. 88-791675-84	
DES APVL		REF. DWG. ING7584		DATE 06/01/95	
				ORDER NO.	



Figure 11 Outline Drawing, 750 kVA (Low Link - 180 Cells)

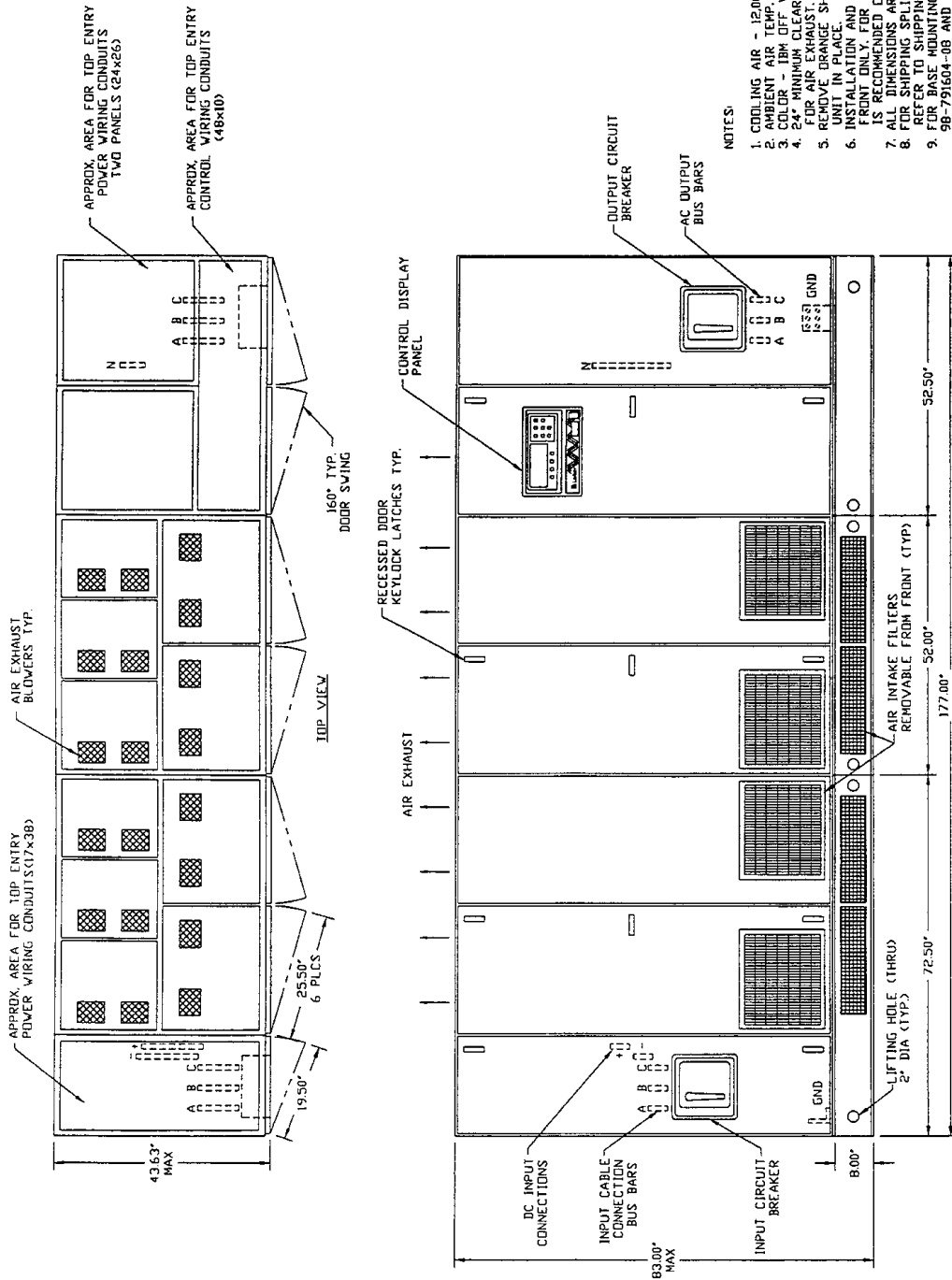


- NOTES:
1. COOLING AIR - 11,000 CFM.
 2. AMBIENT AIR TEMP. RANGE. 32-104 °F (0-40 °C)
 3. COLOR - 1BM OFF WHITE.
 4. 2" MINIMUM CLEARANCE ABOVE UNIT REQUIRED
 5. REMOVE ORANGE SHIPPING BRACKETS BEFORE SETTING UNIT IN PLACE
 6. INSTALLATION AND SERVICE ACCESS REQUIRED IN FRONT ONLY.
 7. ALL DIMENSIONS ARE IN INCHES.
 8. FOR SHIPPING SPLIT INFORMATION AND WEIGHTS REFER TO SHIPPING SPLIT DETAIL.
 9. FOR BASE MOUNTING PATTERN REFER TO DRAWING 88-791613-06.
 10. FOR BUSSING DETAIL REFER TO DRAWING 88-791676-44.

DRAWN BY B FISH		SHEET NO 1 OF 1		TITLE OUTLINE DRAWING	
CHK BY J CAMPBELL		EON NO		750 KVA - 180 CELL	
DES APVL		REF. DWG. IN67624		FRONT ACCESS MULTI-MODULE UPS	
		DWG. NO. 88-791676-24		DATE 06/06/95	
		REV. NO.		ORDER NO.	
		1		1	



Figure 12 Outline Drawing, 1000 kVA

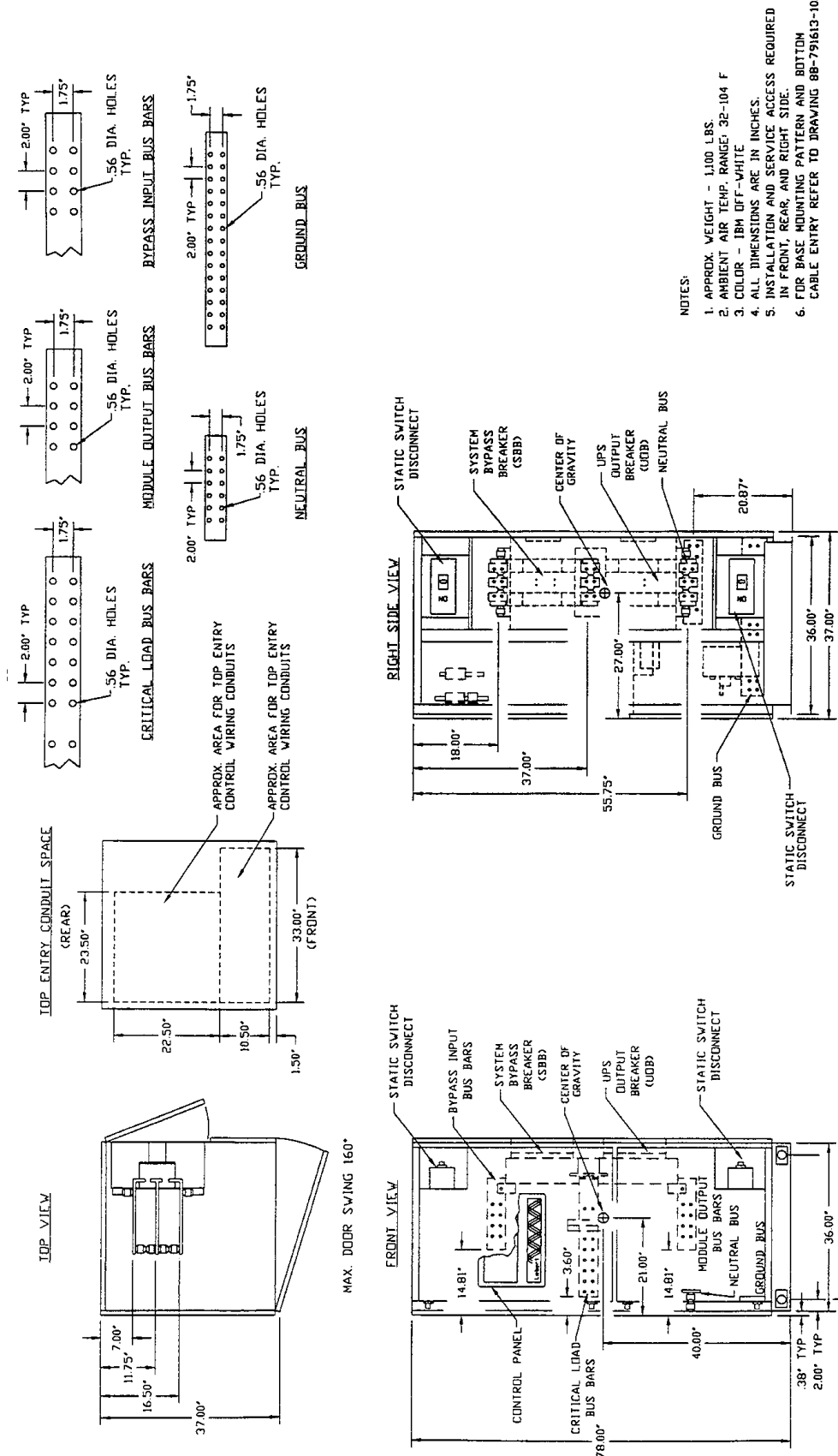


- NOTES:
1. COOLING AIR - 12000 CFM.
 2. AMBIENT AIR TEMP. RANGE. 32-104 °F (0-40 °C)
 3. COLOR - IBM OFF WHITE.
 4. 24" MINIMUM CLEARANCE ABOVE UNIT REQUIRED FOR AIR EXHAUST.
 5. REMOVE ORANGE SHIPPING BRACKETS BEFORE SETTING UNIT IN PLACE.
 6. INSTALLATION AND SERVICE ACCESS REQUIRED IN REAR OF UNIT FOR WIRING AND SERVICE ACCESS.
 7. ALL DIMENSIONS ARE IN INCHES.
 8. FOR SHIPPING SPLIT INFORMATION AND WEIGHTS REFER TO SHIPPING PATTERN DETAIL.
 9. FOR BASE MOUNTING PATTERN REFER TO DRAWING 98-791604-08 AND 98-791604-09.
 10. FOR BUSSING DETAIL REFER TO DRAWING 88-791685-44.

DRAWN BY B FISH		SHEET NO 1 OF 1		TITLE OUTLINE DRAWING 1000 KVA FRONT ACCESS MULTI-MODULE UPS 480 V AND 600 V SERIES 600	
CHK BY J CAMPBELL		ECN NO		DWG. NO. 88-791685-24	
DES' APVL		REF. DWG. IN68524		DATE 06/07/95	
				ORDER NO.	



Figure 13 Outline Drawing, System Control Cabinet (SCCB) 640 to 800 Amps



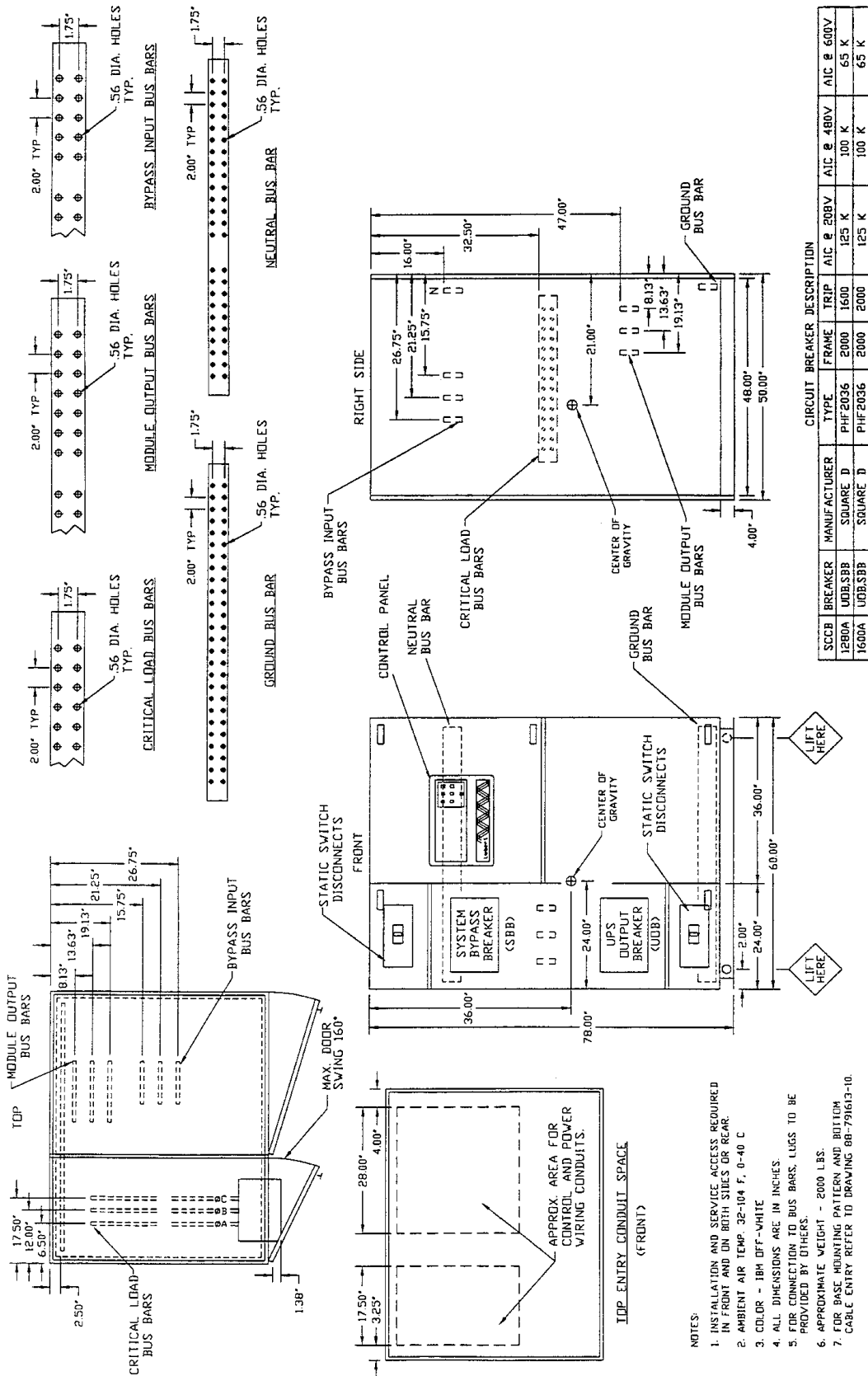
- NOTES:
1. APPROX. WEIGHT - 1100 LBS.
 2. AMBIENT AIR TEMP. RANGE: 32-104 F
 3. COLOR - IBM OFF-WHITE
 4. ALL DIMENSIONS ARE IN INCHES.
 5. INSTALLATION AND SERVICE ACCESS REQUIRED IN FRONT, REAR, AND RIGHT SIDE.
 6. FOR BASE MOUNTING PATTERN AND BOTTOM CABLE ENTRY REFER TO DRAWING 88-791613-10.

SCCB BREAKER	MANUFACTURER	TYPE	FRAME	TRIP	AIC @ 480V	AIC @ 600V
640 A	UOB/SBB	MHL36600	1000	800	65 K	25 K
800 A	UOB/SBB	MHL361000	1000	1000	65 K	25 K

DRAWN BY B FISH		SHEET NO 1 OF 1	
CHK BY J CAMPBELL		ECN NO	
DES APVL		REF. DWG. IN61423	
TITLE SYSTEM CONTROL CABINET (SCCB) 640 800 AMP SERIES 600			
DWG. NO. 88-791614-23		DATE 06/08/95	
REV. NO. 1		ORDER NO.	



Figure 14 Outline Drawing, System Control Cabinet (SCCB) 1280 to 1600 Amps



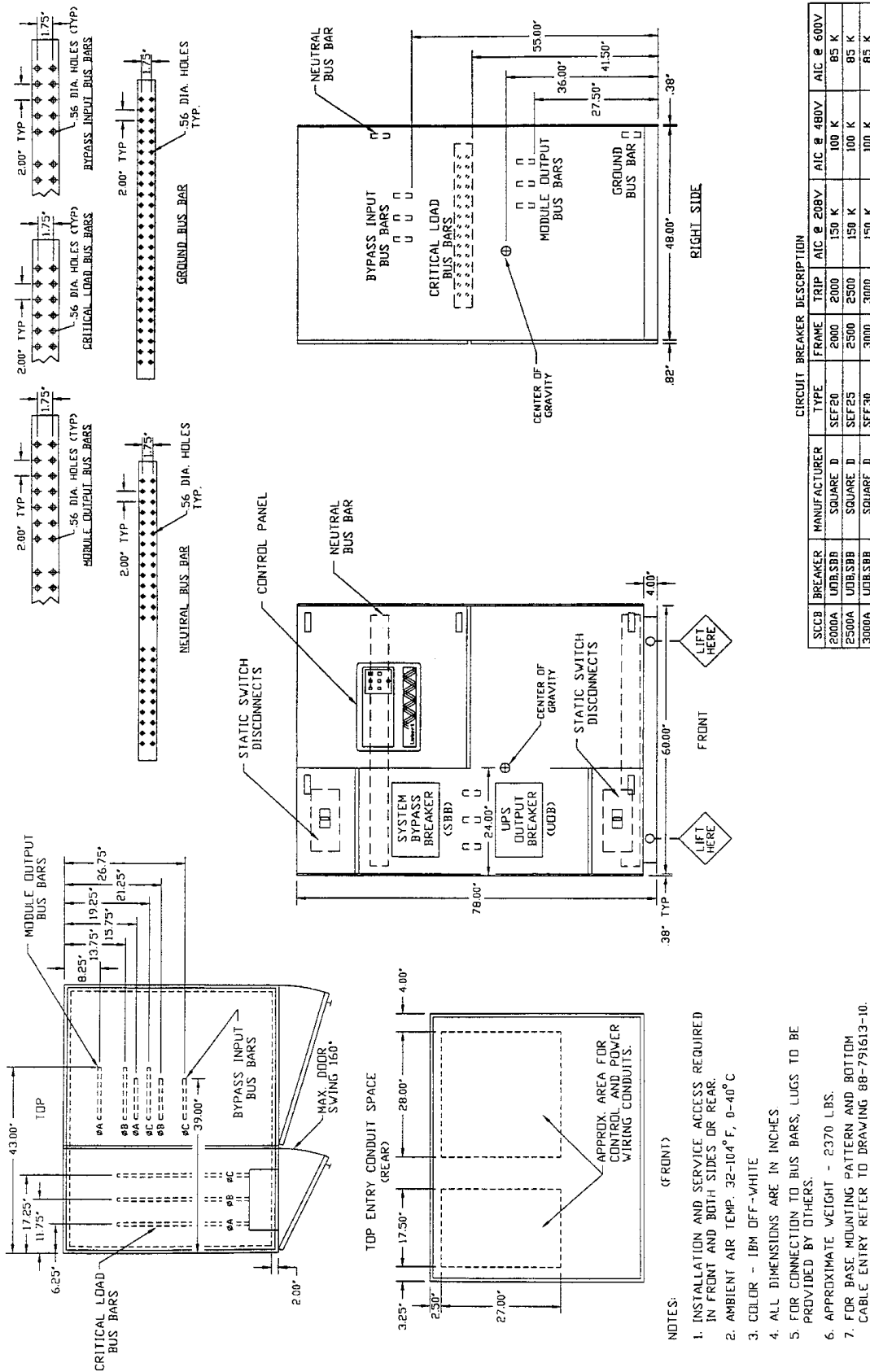
CIRCUIT BREAKER DESCRIPTION					
SCCB BREAKER	MANUFACTURER	TYPE	FRAME	TRIP	AIC @ 600V
1280A	UDS/SBB	PHF2036	2000	1600	100 K
1600A	UDS/SBB	PHF2036	2000	2000	125 K
					100 K
					65 K
					65 K

- NOTES:
1. INSTALLATION AND SERVICE ACCESS REQUIRED IN FRONT AND ON BOTH SIDES OR REAR.
 2. AMBIENT AIR TEMP. 32-104 F. 0-40 C
 3. COLOR - 1BM OFF-WHITE
 4. ALL DIMENSIONS ARE IN INCHES.
 5. FOR CONNECTION TO BUS BARS, LUGS TO BE PROVIDED BY OTHERS.
 6. APPROXIMATE WEIGHT - 2000 LBS.
 7. FOR BASE MOUNTING PATTERN AND BOTTOM CABLE ENTRY REFER TO DRAWING 88-791610-10.

DRAWN BY B FISH	SHEET NO 1 OF 1	TITLE OUTLINE DRAWING SYSTEM CONTROL CABINET (SCCB) 1280 - 1600 AMP SERIES 600	
		DWG. NO. 88-791614-24	DATE 06/08/95
CHK BY J CAMPBELL	ECN NO	REV. NO. 1	ORDER NO.
DES APVL	REF. DWG. IN61424	FILE NAME: IN61424.DWG	



Figure 15 Outline Drawing, System Control Cabinet (SCCB) 2000 to 3000 Amps



CIRCUIT BREAKER DESCRIPTION

SCCB BREAKER	MANUFACTURER	TYPE	FRAME	TRIP	AIC @ 208V	AIC @ 480V	AIC @ 600V
2000A	SQUARE D	SEF20	2000	150 K	100 K	100 K	85 K
2500A	SQUARE D	SEF25	2500	150 K	100 K	100 K	85 K
3000A	SQUARE D	SEF30	3000	3000	150 K	100 K	85 K

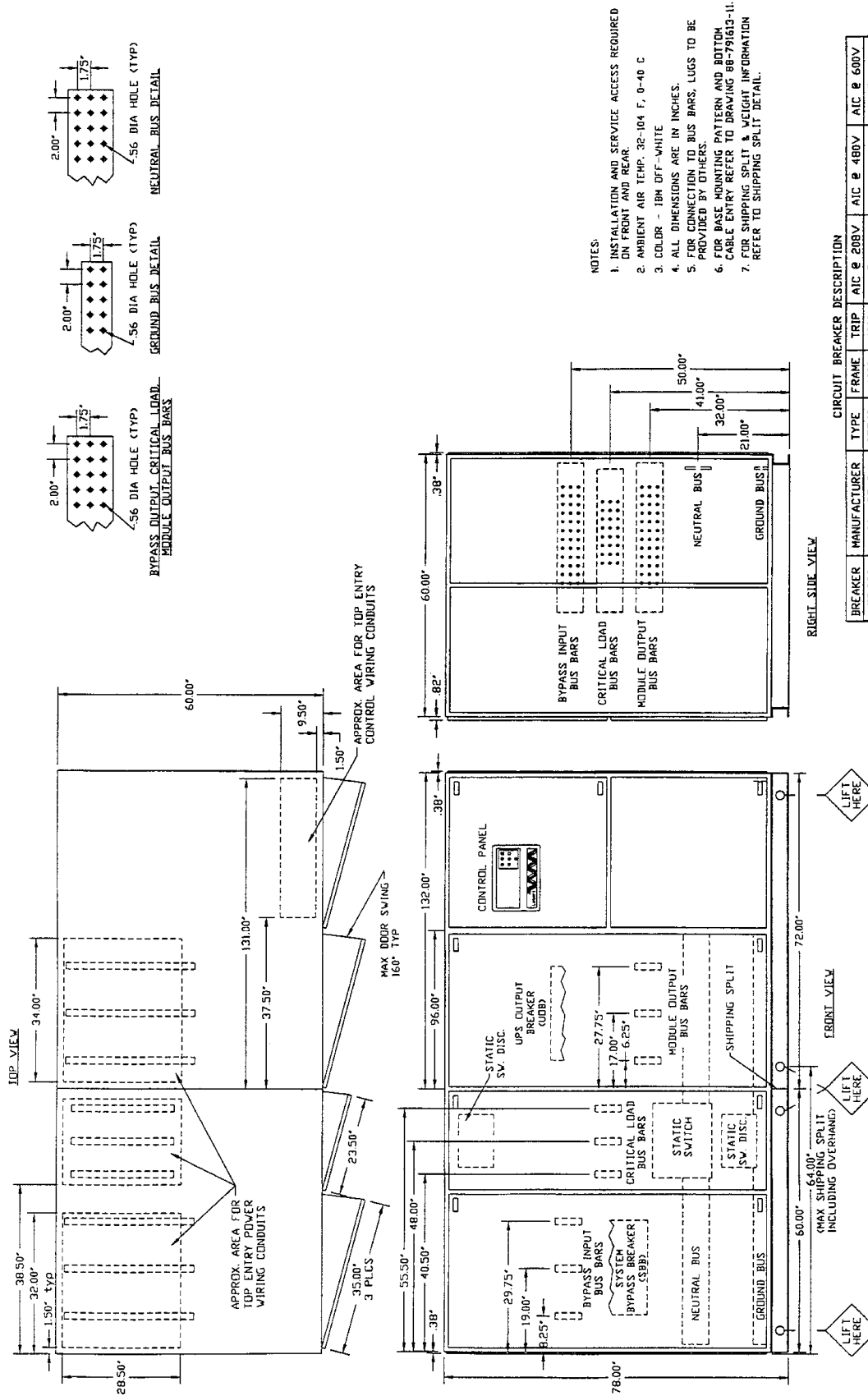
- NOTES:
1. INSTALLATION AND SERVICE ACCESS REQUIRED IN FRONT AND BOTH SIDES OR REAR.
 2. AMBIENT AIR TEMP. 32-104° F, 0-40° C
 3. COLOR - IBM OFF-WHITE
 4. ALL DIMENSIONS ARE IN INCHES
 5. FOR CONNECTION TO BUS BARS, LUGS TO BE PROVIDED BY OTHERS.
 6. APPROXIMATE WEIGHT - 2370 LBS.
 7. FOR BASE MOUNTING PATTERN AND ROTATION
- CABLE ENTRY REFER TO DRAWING 88-791613-10.

DRAWN BY B FISH		SHEET NO 1 OF 1	
CHK BY J CAMPBELL		ECN NO	
DES APVL IN61425		REF. DWG.	
TITLE OUTLINE DRAWING SYSTEM CONTROL CABINET (SCCB) 2000 - 3000 AMP SERIES 600			
DWG. NO. 88-791614-25		DATE 06/08/95	
REV. NO. 1		ORDER NO.	

FILE NAME: IN61425.DWG



Figure 16 Outline Drawing, System Control Cabinet (SCCB) 4000 Amps




- NOTES:
1. INSTALLATION AND SERVICE ACCESS REQUIRED ON FRONT AND REAR.
 2. AMBIENT AIR TEMP. 32-104 F, 0-40 C
 3. COLOR - 1BM DTF-WHITE
 4. ALL DIMENSIONS ARE IN INCHES.
 5. FOR CONNECTION TO BUS BARS, LUGS TO BE PROVIDED BY OTHERS.
 6. FOR BASE MOUNTING PATTERN AND BOTTOM CABLE ENTRY REFER TO DRAWING 88-791613-11.
 7. FOR SHIPPING SPLIT & WEIGHT INFORMATION REFER TO SHIPPING SPLIT DETAIL.

CIRCUIT BREAKER DESCRIPTION

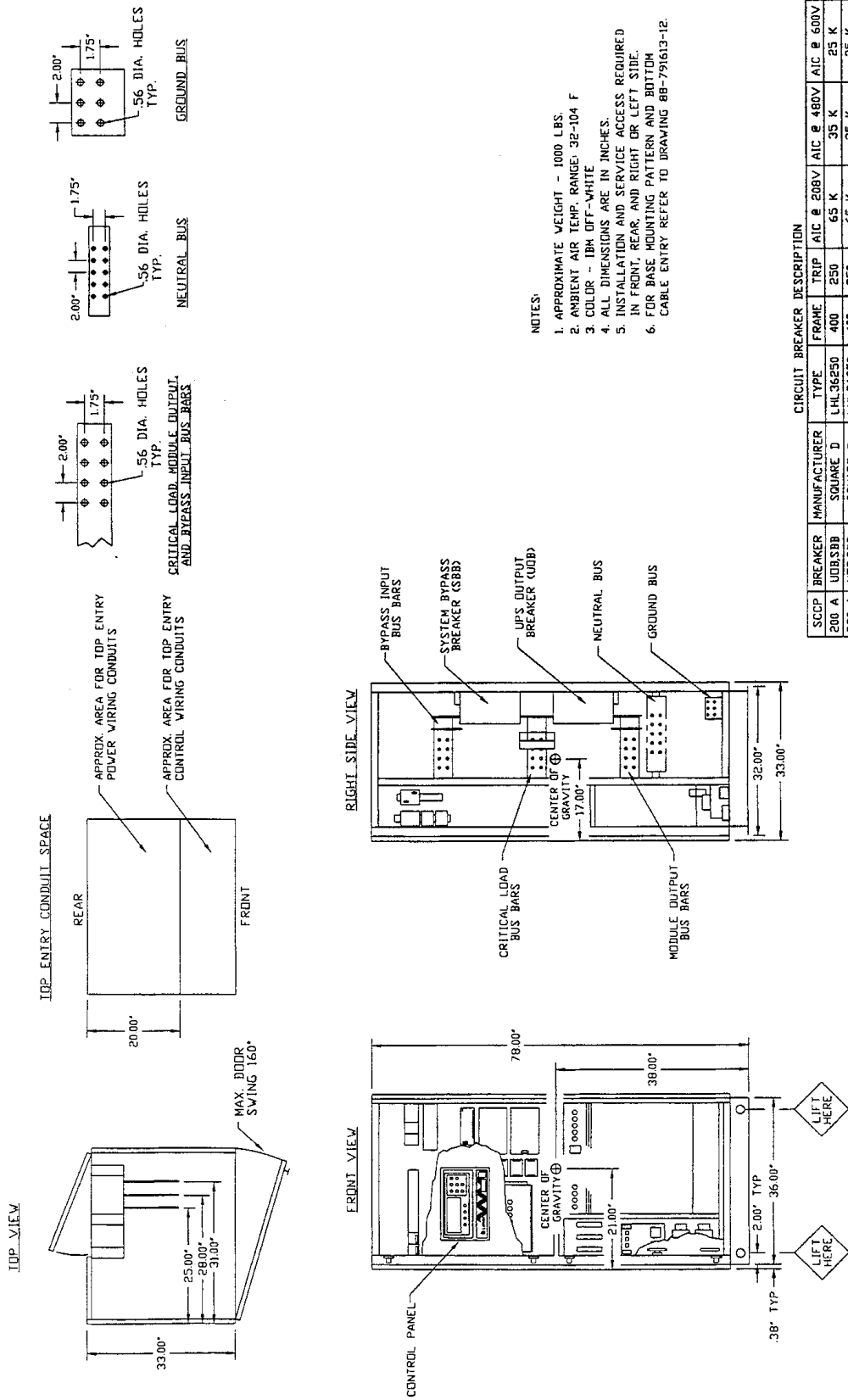
BREAKER	MANUFACTURER	TYPE	FRAME	TRIP	AIC @ 208V	AIC @ 480V	AIC @ 600V
UBB.SBB	SEF.40	4000	4000	150 K	100 K	85 K	

DRAWN BY B FISH		SHEET NO 1 OF 1		TITLE OUTLINE DRAWING SYSTEM CONTROL CABINET (SCCB) 4000 AMP SERIES 600	
CHK BY J CAMPBELL		ECN NO		DVG. NO. 88-791614-26	
DES APVL		REF. DVG. IN61426		DATE 06/09/95	
				ORDER NO.	


 9650 JERONIMO RD.
 IRVINE, CALIFORNIA 92718

FILE NAME: IN61426.DWG

Figure 17 Outline Drawing, System Control Cabinet (SCCP) 200 to 480 Amps




- NOTES:
1. APPROXIMATE WEIGHT - 1000 LBS.
 2. AMBIENT AIR TEMP. RANGE: 32-104 F
 3. COLOR - IBM OFF-WHITE
 4. ALL DIMENSIONS ARE IN INCHES.
 5. INSTALLATION AND SERVICE ACCESS REQUIRED IN FRONT, REAR, AND RIGHT OR LEFT SIDE.
 6. FOR BASE MOUNTING, PATTERN AND BOTTOM CABLE ENTRY REFER TO DRAWING 88-791613-12.

CIRCUIT BREAKER DESCRIPTION

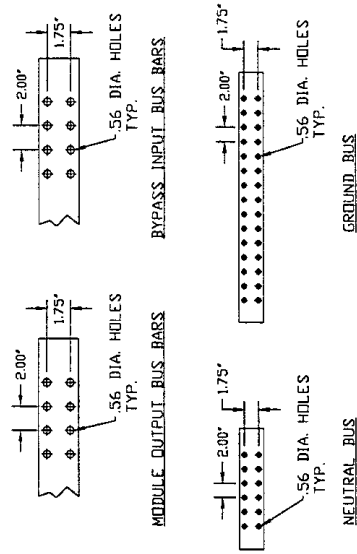
SCCP	BREAKER	MANUFACTURER	TYPE	FRAME	TRIP	AIC @ 208V	AIC @ 480V	AIC @ 600V
200 A	UDB3BB	SQUARE D	LHL36250	400	250	65 K	35 K	25 K
260 A	UDB3BB	SQUARE D	LHL36350	400	350	65 K	35 K	25 K
360 A	UDB3BB	SQUARE D	MHL36450	1000	450	65 K	65 K	25 K
480 A	UDB3BB	SQUARE D	MHL36600	1000	600	65 K	65 K	25 K

DRAWN BY B FISH		SHEET NO 1 OF 1		TITLE OUTLINE DRAWING SYSTEM CONTROL CABINET (SCCP) 200 - 480 AMP SERIES 600	
CHK BY J CAMPBELL		ECN NO		DWG. NO. 88-791614-27	
DES. APVL		REF. DWG. ING1427		DATE 06/08/95	
				ORDER NO.	

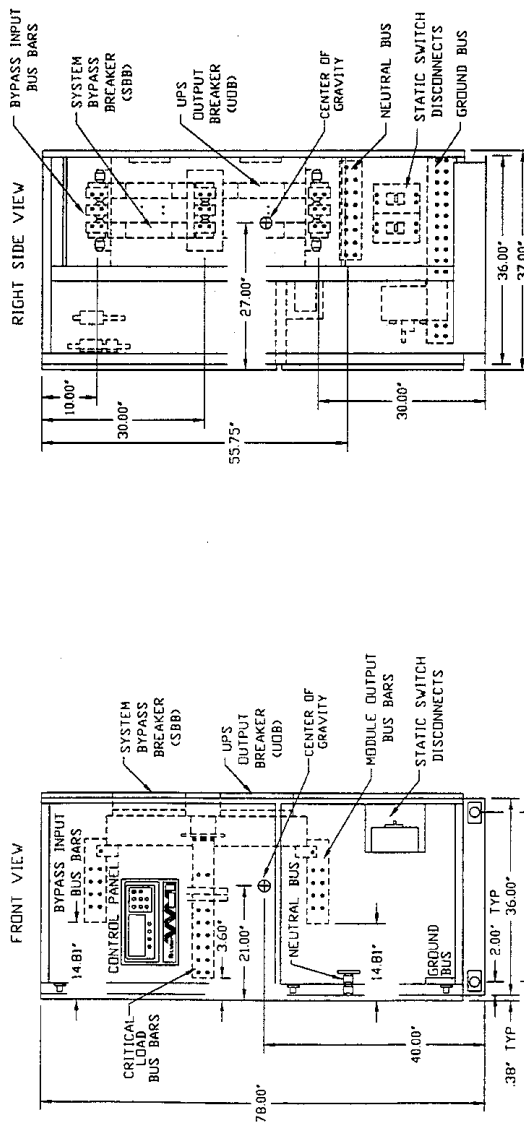
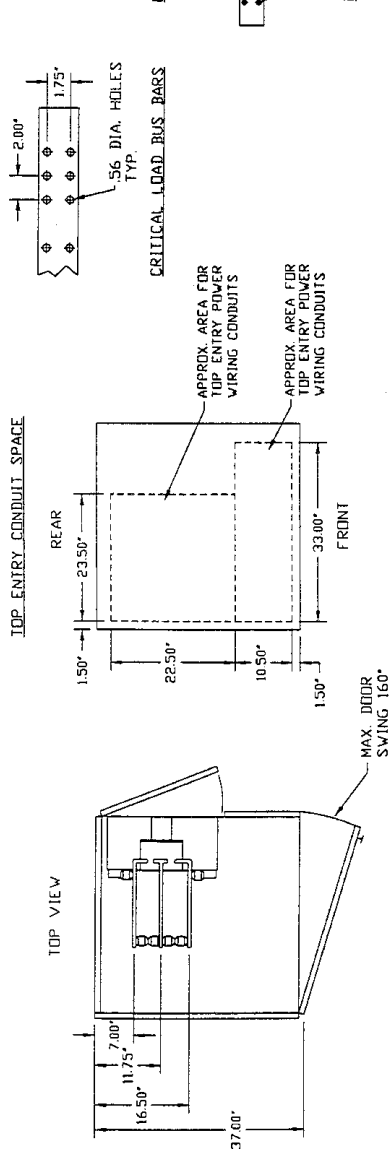

 9850 JERONIMO RD.
 IRVINE, CALIFORNIA 92718

FILE NAME: ING1427.DWG

Figure 18 Outline Drawing, System Control Cabinet (SCCP) 560 to 960 Amps



- NOTES:
1. APPROXIMATE WEIGHT - 1000 LBS.
 2. AMBIENT AIR TEMP. RANGE: 32-104 F
 3. COLOR - 10M OFF-WHITE
 4. ALL DIMENSIONS ARE IN INCHES.
 5. INSTALLATION AND SERVICE ACCESS REQUIRED IN FRONT, RIGHT AND REAR OR LEFT SIDE.
 6. CABLE ENTRY REFER TO DRAWING 88-791613-13.

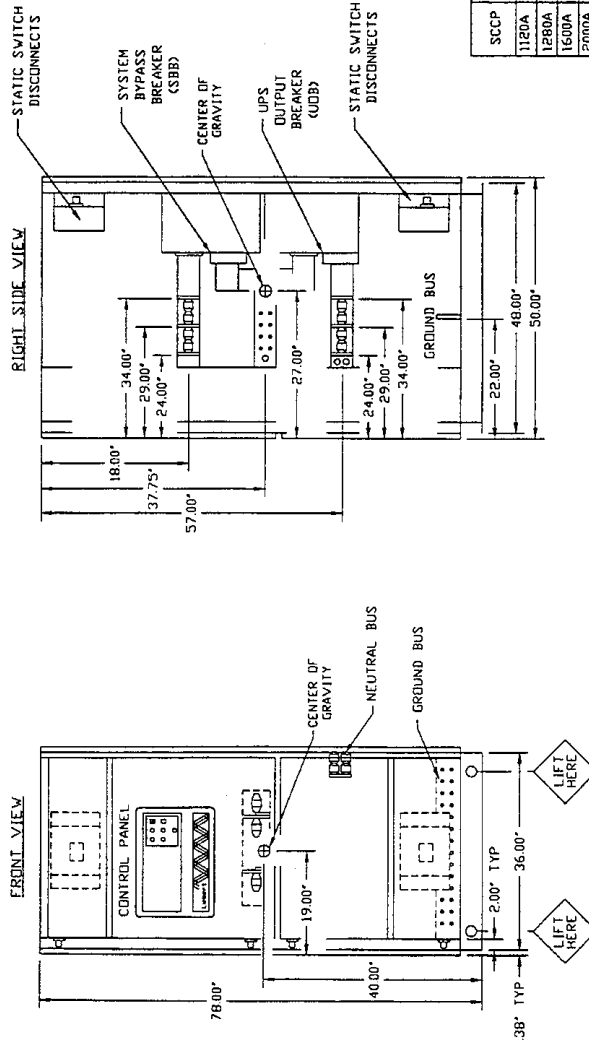
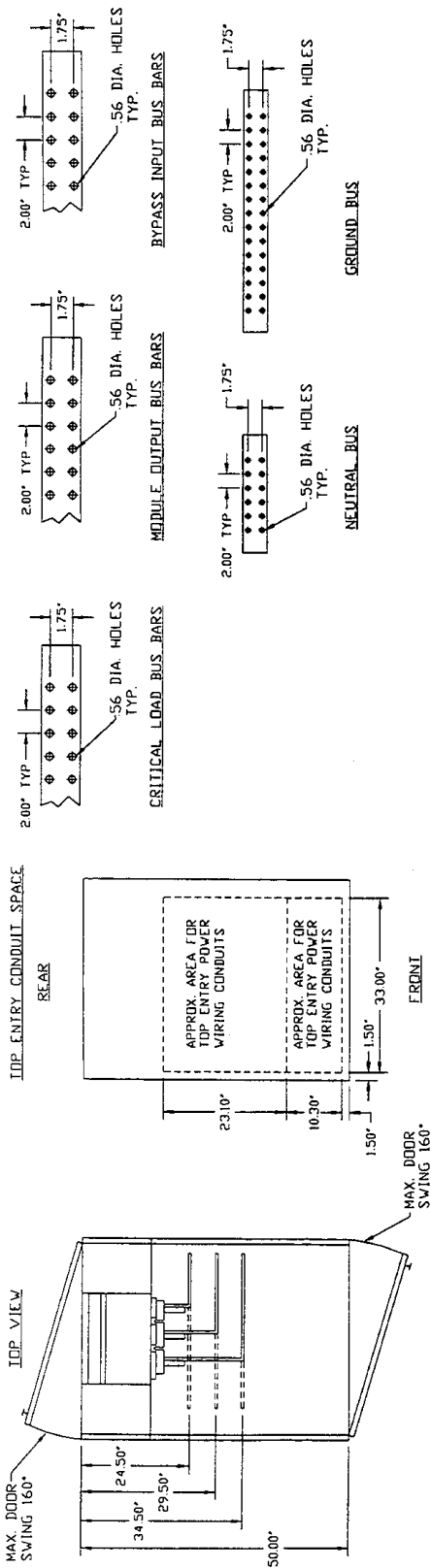


SCCP BREAKER		CIRCUIT BREAKER DESCRIPTION				
MANUFACTURER	TYPE	FRAME	TRIP	AIC @ 200V	AIC @ 480V	AIC @ 600V
560 A UOB/SBB	SQUARE D	MHL36700	1000	700	65 K	65 K
640 A UOB/SBB	SQUARE D	MHL36800	1000	800	65 K	65 K
800 A UOB/SBB	SQUARE D	MHL361000	1000	1000	65 K	65 K
960 A UOB/SBB	SQUARE D	MHL361200	1200	1200	65 K	65 K

DRAWN BY		SHEET NO		TITLE	
B FISH		1 OF 1		OUTLINE DRAWING	
CHK BY		ECN NO		SYSTEM CONTROL CABINET (SCCP)	
J CAMPBELL				560 - 960 AMP	
DES APVL		REF. DWG.		SERIES 600	
IN61428		IN61428			
DWG. NO.		DATE		REV. NO.	
88-791614-28		06/08/95		ORDER NO.	
1					



Figure 19 Outline Drawing, System Control Cabinet (SCCP) 1280 to 2000 Amps



NOTES:

1. APPROXIMATE WEIGHTS: 1250 LBS. (1280 - 1600 AMP)
1400 LBS. (2000 AMP)
2. AMBIENT AIR TEMP. RANGE: 32-104 F
3. COLOR - 1BM OFF-WHITE
4. ALL DIMENSIONS ARE IN INCHES.
5. INSTALLATION AND SERVICE ACCESS REQUIRED IN FRONT, REAR, AND ONE SIDE.
6. FOR BASE MOUNTING PATTERN AND BOTTOM CABLE ENTRY REFER TO DRAWING 88-791613-13.

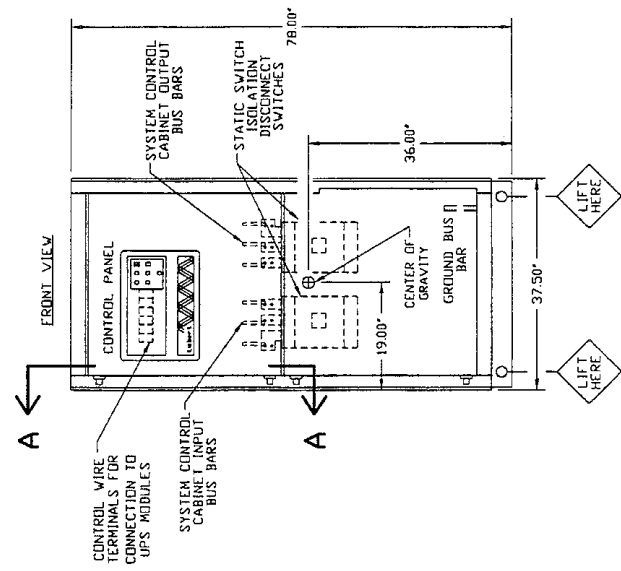
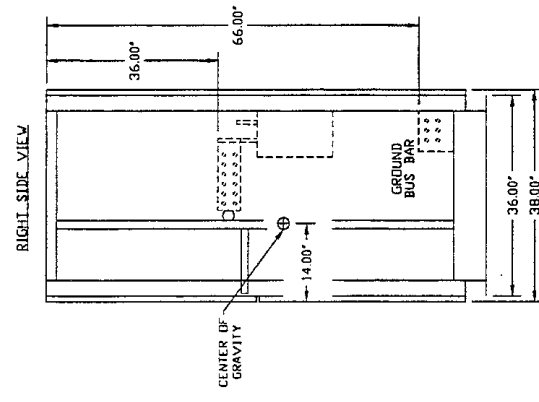
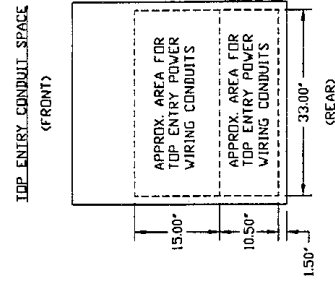
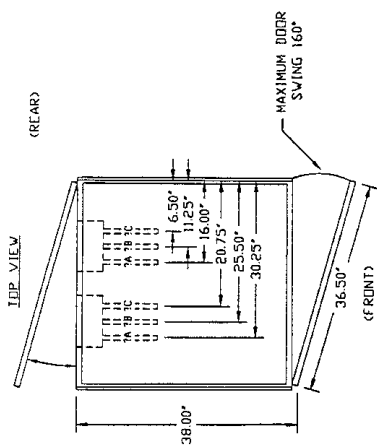
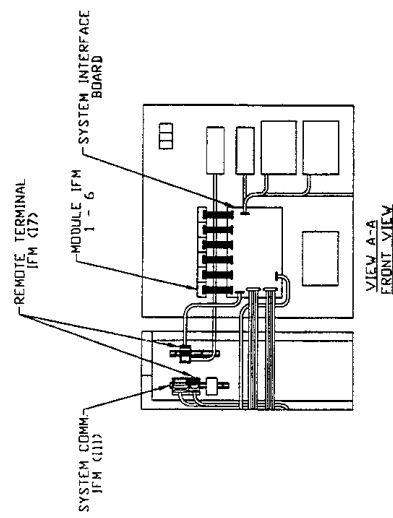
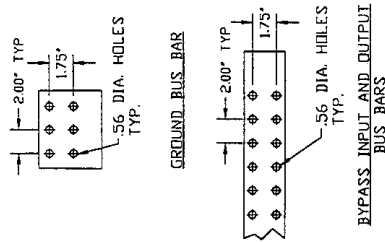
CIRCUIT BREAKER DESCRIPTION

SCCP BREAKER	MANUFACTURER	TYPE	FRAME	TRIP	AIC
1180A	UDBSBB	SQUARE D	PHF2035	2000	1400
1280A	UDBSBB	SQUARE D	PHF2036	2000	1600
1600A	UDBSBB	SQUARE D	PHF2036	2000	125 K
2000A	UDBSBB	SQUARE D	SEF20	2000	2000
					150 K
					100 K
					100 K
					65 K
					65 K
					100 K
					100 K
					85 K

DRAWN BY B. FISH		SHEET NO 1 OF 1	
CHK BY J. CAMPBELL		ECN NO	
DES. APVL ING1429		REF. DWG.	
TITLE OUTLINE DRAWING SYSTEM CONTROL CABINET (SCCP) 1120 - 2000AMP SERIES 600			
DWG. NO. 88-791614-29		DATE 06/09/95	
REV. NO. 1		ORDER NO.	



Figure 20 Outline Drawing, System Control Cabinet (SCCA) 2000 to 4000 Amps

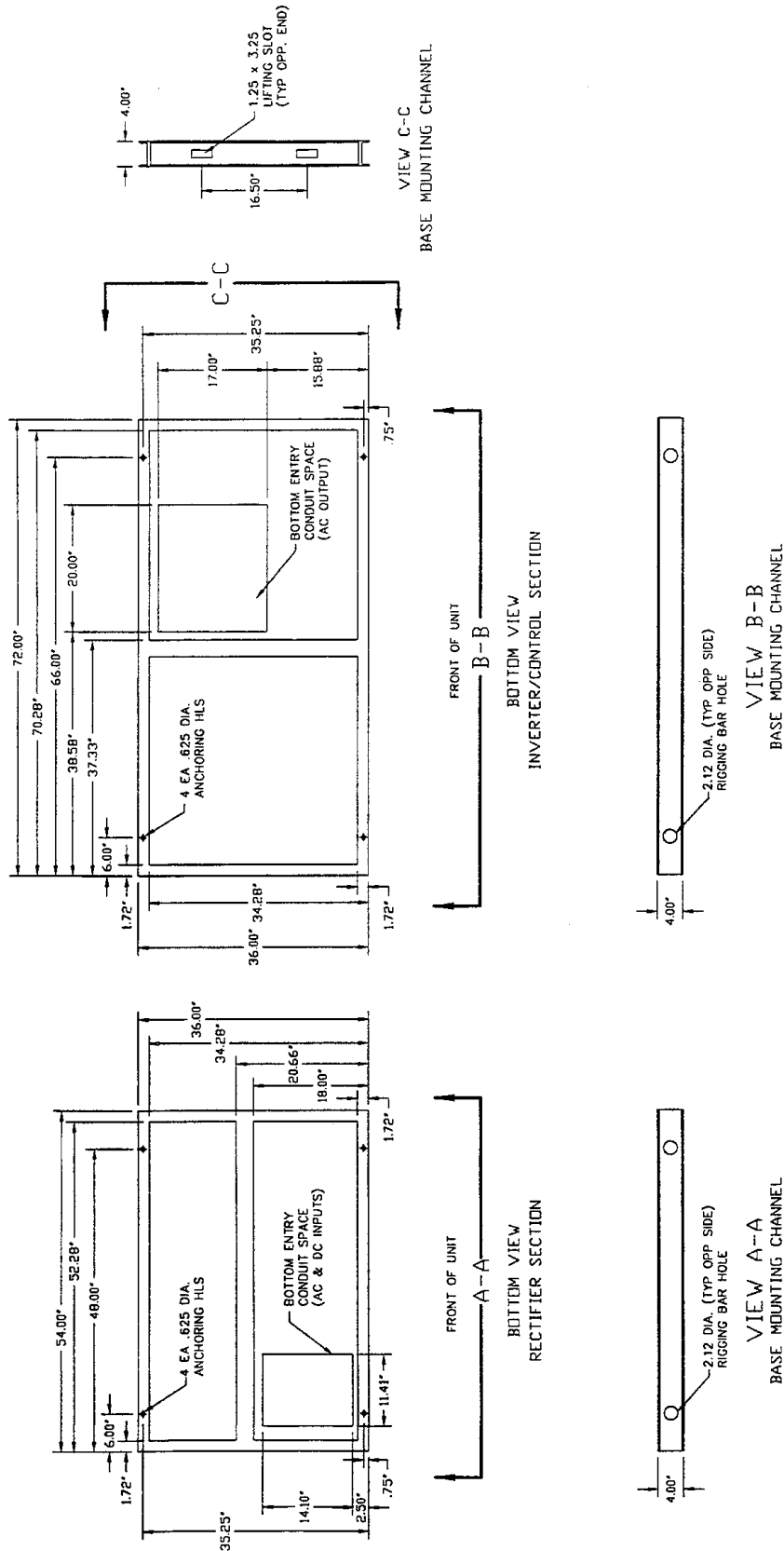


- NOTES:
1. INSTALLATION AND SERVICE ACCESS REQUIRED ON FRONT, REAR, AND ONE SIDE.
 2. AMBIENT AIR TEMP. 32-104 F. 0-40 C
 3. COLOR - 1BM OFF-WHITE
 4. ALL DIMENSIONS ARE IN INCHES.
 5. FOR CONNECTION TO BUS BARS, LUGS TO BE PROVIDED BY OTHERS.
 6. APPROXIMATE WEIGHT - 900 LBS.
 7. FOR BASE MOUNTING PATTERN AND BOTTOM CABLE ENTRY REFER TO DRAWING 88-791613-14.

DRAWN BY B. FISH		SHEET NO. 1 OF 1		TITLE OUTLINE DRAWING SYSTEM CONTROL CABINET (SCCA) SYSTEM 2000 - 4000 AMP STAND ALONE CONFIGURATION SERIES 600	
CHK BY J. CAMPBELL		ECN NO.		DRAWING NO. 88-791614-30	
DES APVL		REF. DWG. IN61430		DATE 06/09/95	
				ORDER NO.	



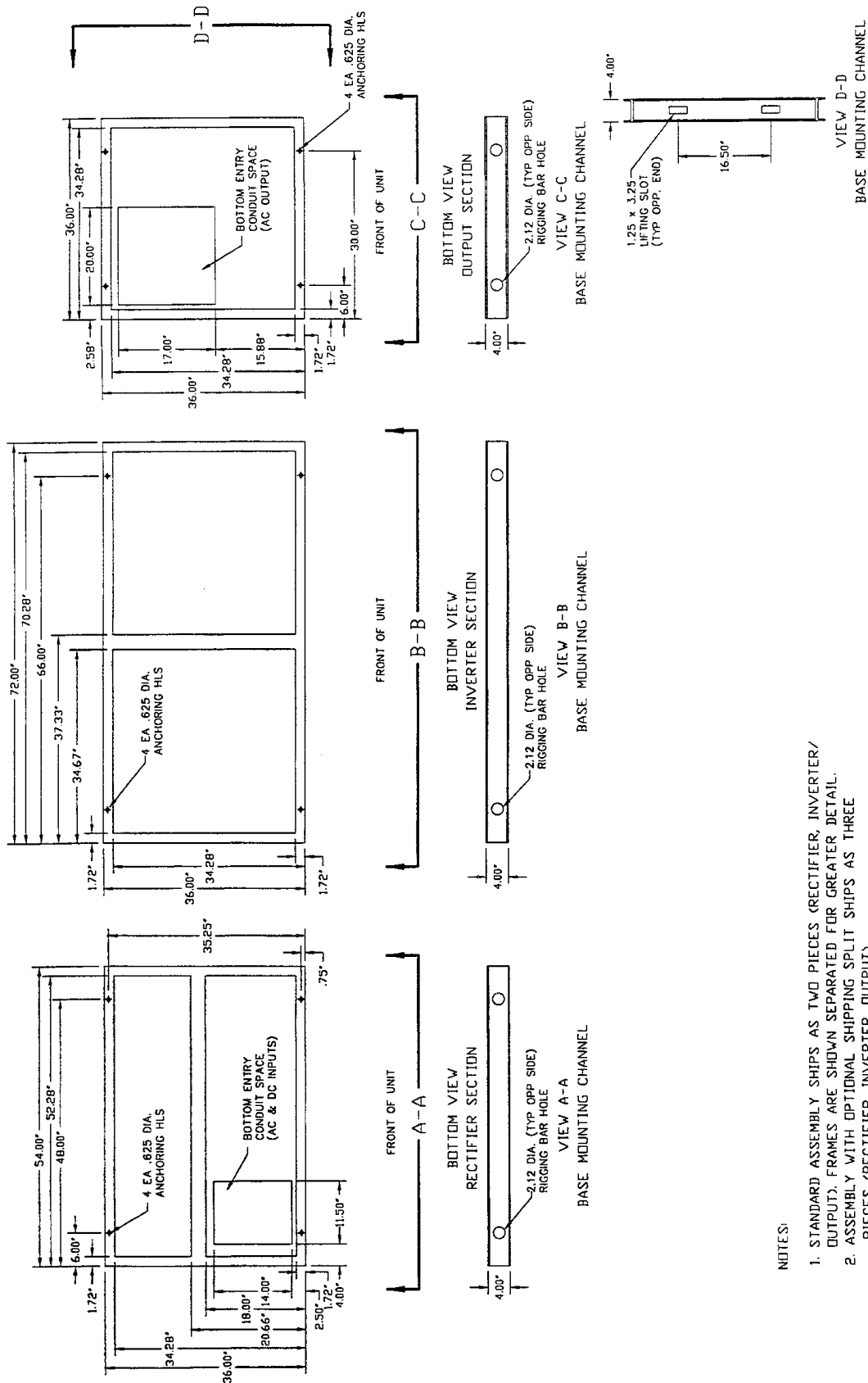
Figure 21 Base Mounting Details, 338 kVA



DRAWN BY B. FISH		SHEET NO 1 OF 1		TITLE BASE MOUNTING PATTERNS 338 KVA SINGLE AND MULTI MODULE SERIES 600	
CHK BY J. CAMPBELL		ECN NO		DWG. NO. 88-791613-02	DATE 06/14/95
DES. APVL		REF. DWG.		REV. NO. 1	ORDER NO.
DMG1302		DMG1302		FILE NAME: DMG1302.DWG	




Figure 22 Base Mounting Details, 400 and 500 kVA



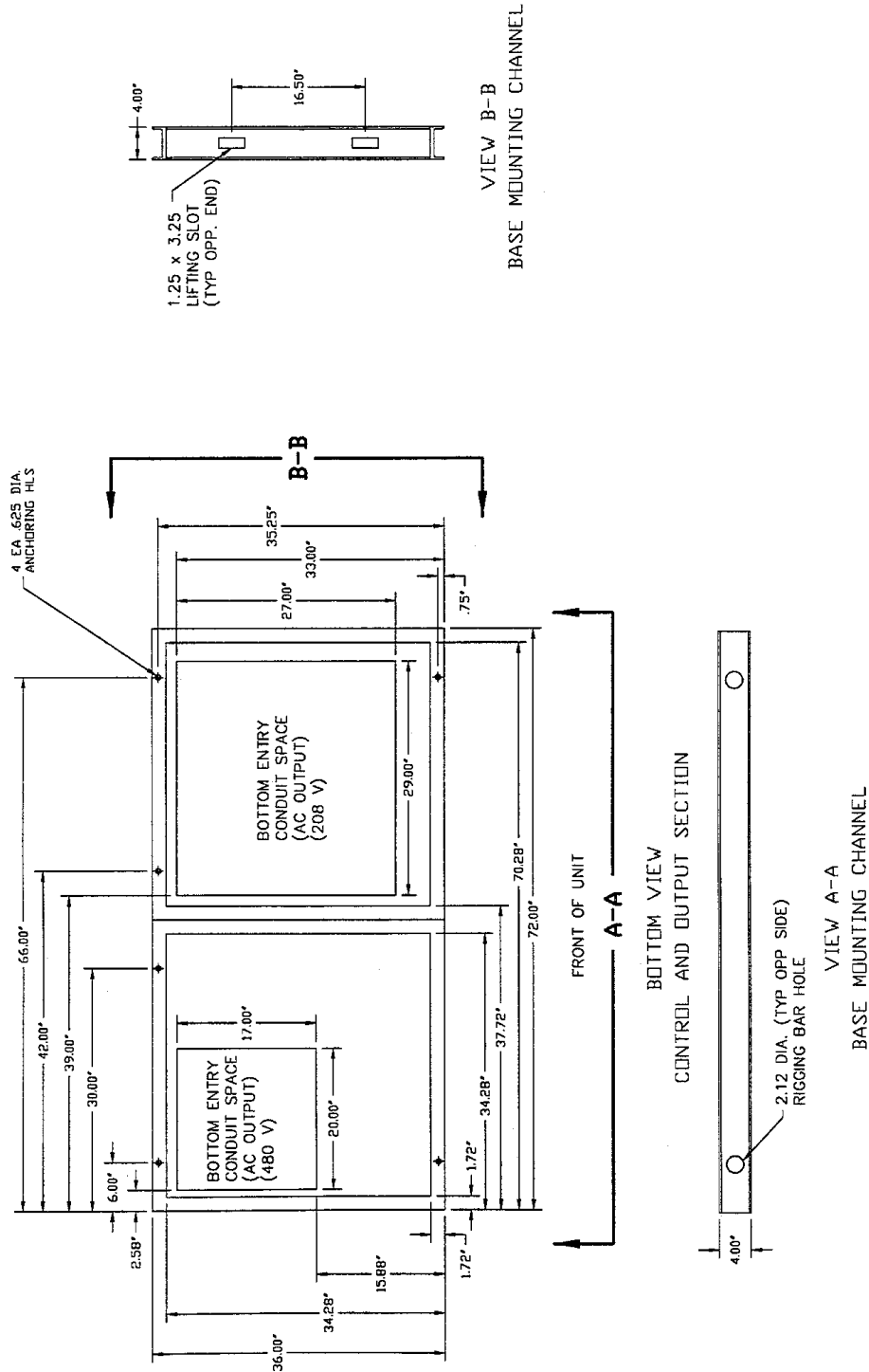
NOTES:

1. STANDARD ASSEMBLY SHIPS AS TWO PIECES (RECTIFIER, INVERTER/ OUTPUT). FRAMES ARE SHOWN SEPARATED FOR GREATER DETAIL.
2. ASSEMBLY WITH OPTIONAL SHIPPING SPLIT SHIPS AS THREE PIECES (RECTIFIER, INVERTER, OUTPUT).

DRAWN BY B FISH		SHEET NO 1 OF 1		TITLE BASE MOUNTING PATTERNS 400 AND 500 KVA, 480 AND 600 V SINGLE AND MULTI MODULE SERIES 600	
CHK BY J CAMPBELL		ECN NO		DWG. NO. DM61303	
DES APVL		REV. NO. 1		DATE 06/14/95	
		DWG. NO. 88-791613-03		ORDER NO.	
 9650 JERONIMO RD. IRVINE, CALIFORNIA 92718					

FILE NAME: DM61303.DWG

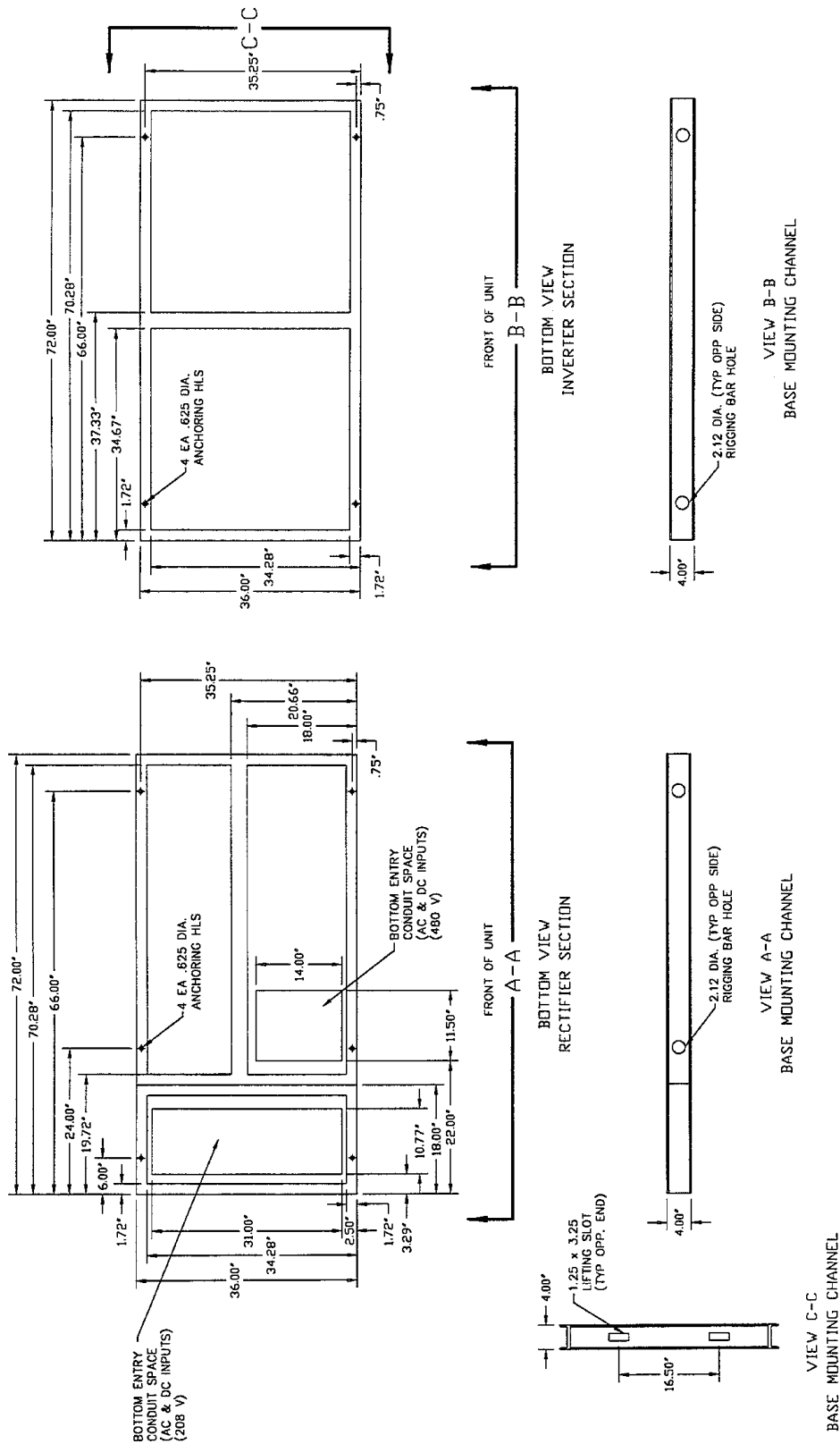
Figure 23 Base Mounting Details, 400 and 500 kVA, 208 VAC, Rectifier and Inverter Sections



DRAWN BY	T HECKMAN	SHEET NO	1 OF 1	TITLE	
CHK BY	J CAMPBELL	ECN NO		BASE MOUNTING DETAILS	
DES APVL		REF. DWG.	DM61306	400 AND 500 KVA 208V OUTPUT SINGLE AND MULTI MODULE UPS CONTROL AND OUTPUT SECTION SERIES 600	
DWG. NO.	88-791613-06	DATE	01/08/96	REV. NO.	
REV. NO.	2	ORDER NO.		FILE NAME: DM61306.DWG	

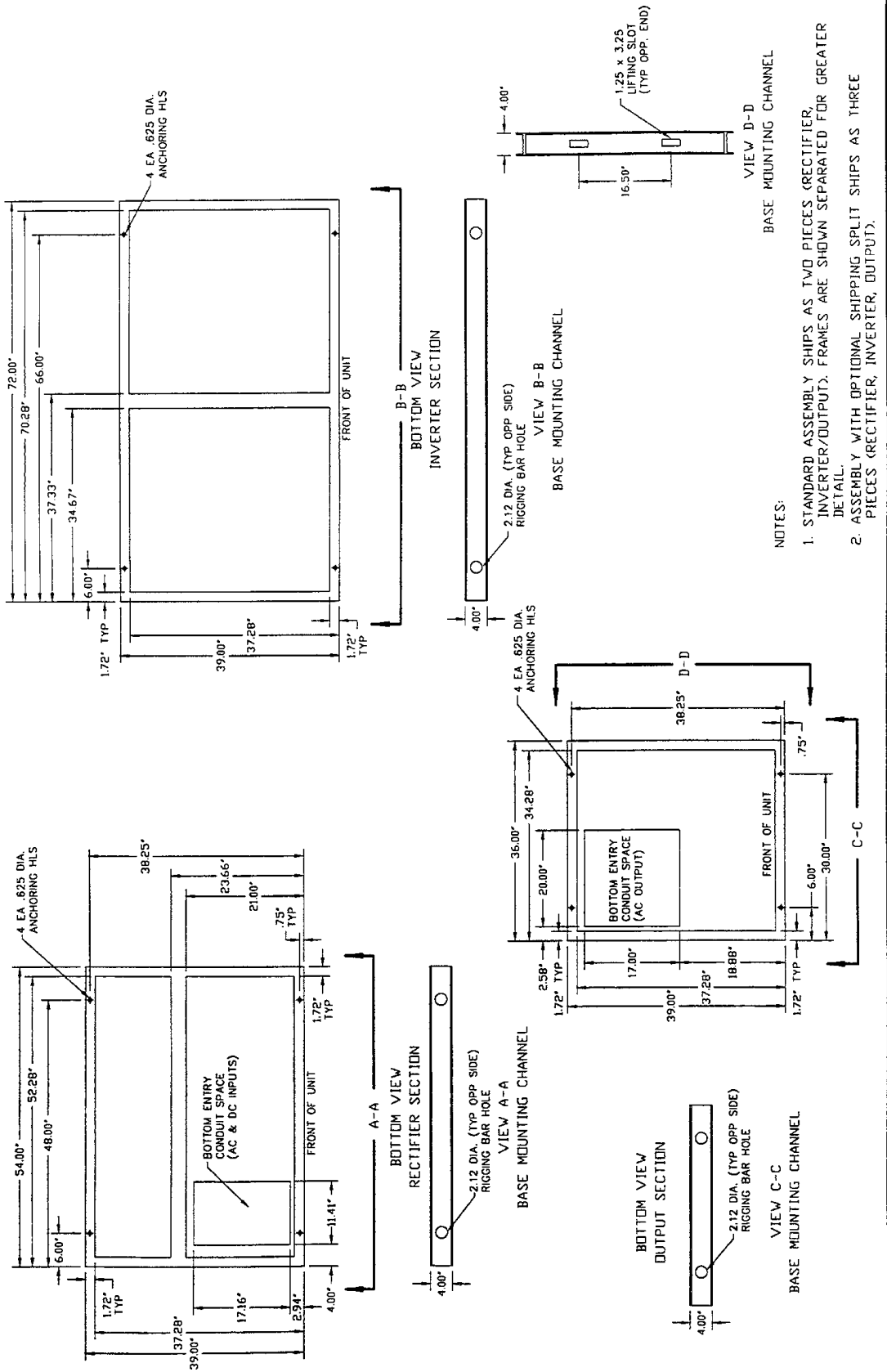


Figure 24 Base Mounting Details, 400 and 500 kVA, 208 VAC, Control and Output Sections



DRAWN BY T HECKMAN		SHEET NO 1 OF 1		TITLE BASE MOUNTING PATTERNS 400 AND 500 KVA 208V INPUT SINGLE AND MULTI MODULE UPS RECTIFIER AND INVERTER SERIES 600	
CHK BY J CAMPBELL		ECN NO		DATE 01/08/96	
DES APVL		REF. DWG. DM61305		ORDER NO.	
				REV. NO. 2	
				DVG. NO. 88-791613-05	
				FILE NAME: DM61305.DWG	
				IRVINE, CALIFORNIA 92718	
				Liabert	

Figure 25 Base Mounting Details, 625 kVA and 750 kVA (High Link - 240 Cells)



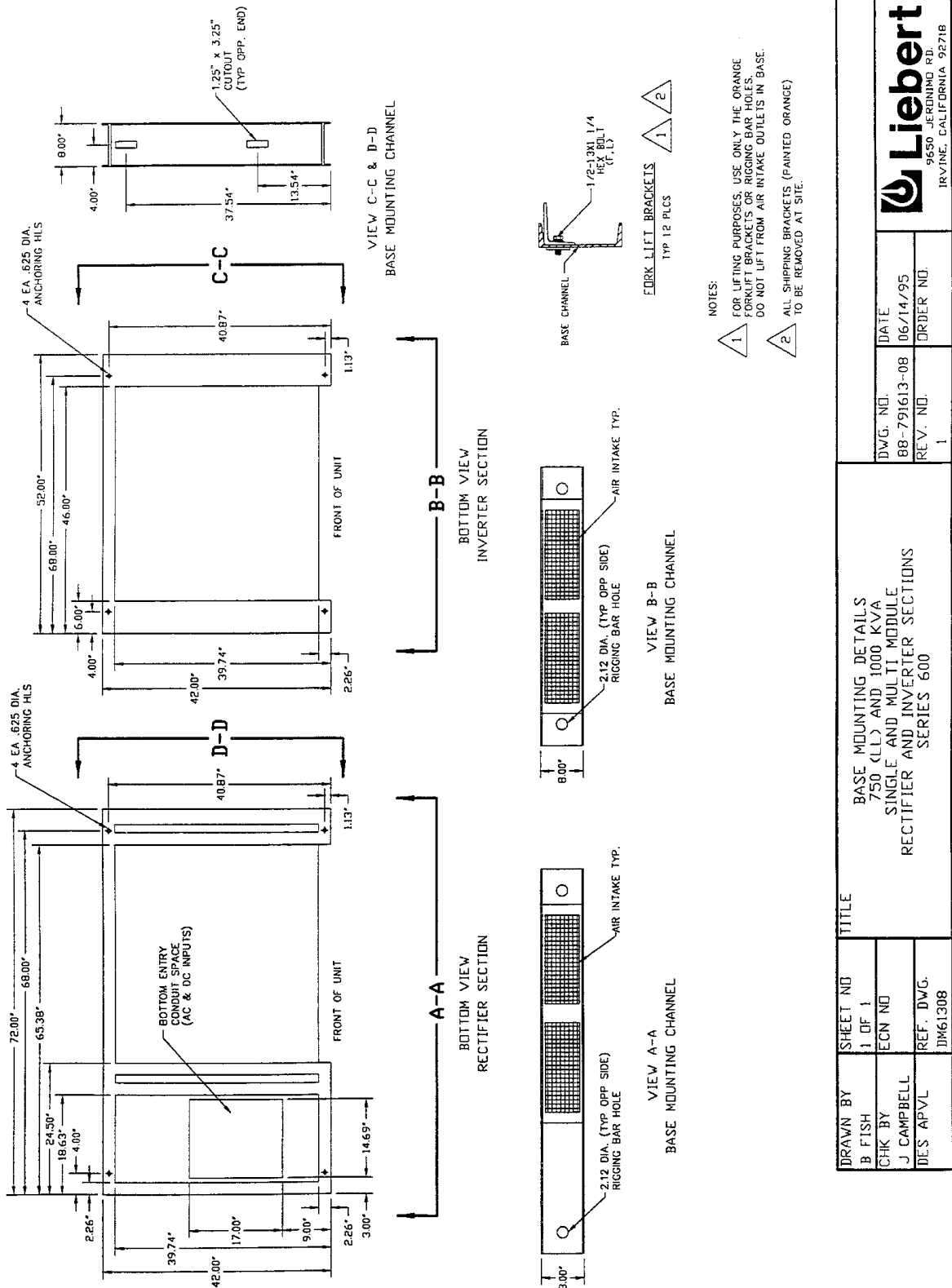
NOTES:
 1. STANDARD ASSEMBLY SHIPS AS TWO PIECES (RECTIFIER, INVERTER/OUTPUT). FRAMES ARE SHOWN SEPARATED FOR GREATER DETAIL.
 2. ASSEMBLY WITH OPTIONAL SHIPPING SPLIT SHIPS AS THREE PIECES (RECTIFIER, INVERTER, OUTPUT).

DRAWN BY B FISH		SHEET NO 1 OF 1		TITLE BASE MOUNTING DETAILS 625 AND 750 (HL) KVA ALL VOLTAGES SINGLE AND MULTI MODULE SERIES 600	
CHK BY J CAMPBELL		ECN NO		DWG. NO. 88-791613-07	
DES APVL		REF. DWG. DM61307		DATE 06/14/95	
				ORDER NO.	
				REV. NO. 1	



FILE NAME: DM61307.DWG

Figure 26 Base Mounting Details, 750 kVA (Low Link - 180 Cells) and 1000 kVA, Rectifier and Inverter Sections

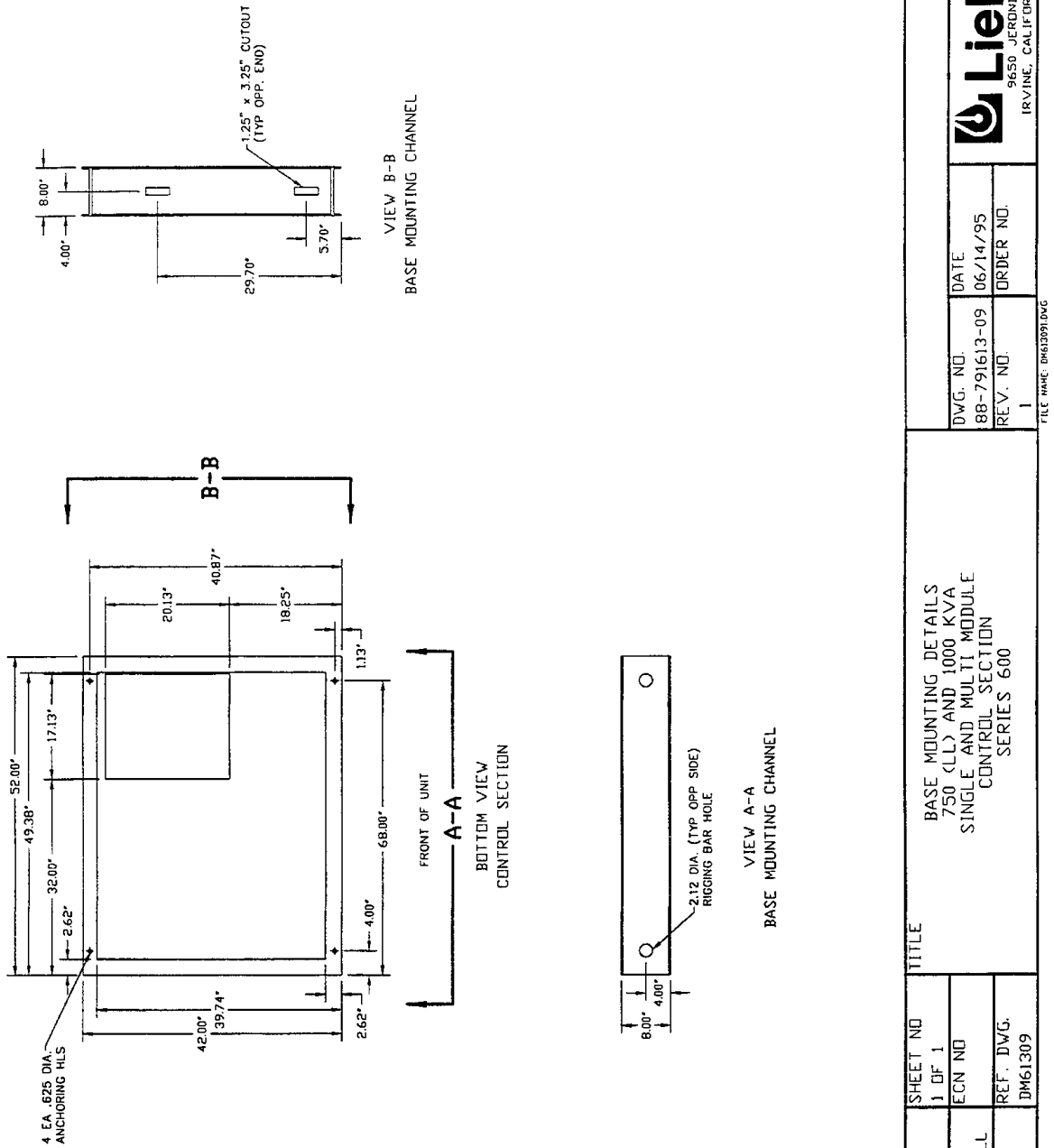


NOTES:
 1 FOR LIFTING PURPOSES, USE ONLY THE ORANGE FORKLIFT BRACKETS OR RIGGING BAR HOLES. DO NOT LIFT FROM AIR INTAKE OUTLETS IN BASE.
 2 ALL SHIPPING BRACKETS (PAINTED ORANGE) TO BE REMOVED AT SITE.

DRAWN BY B FISH		SHEET NO 1 OF 1		TITLE BASE MOUNTING DETAILS 750 (LL) AND 1000 KVA SINGLE AND MULTI MODULE RECTIFIER AND INVERTER SECTIONS SERIES 600	
CHK BY J CAMPBELL		ECN NO		DWG. NO. 88-791613-08	
DES APVL		REF. DWG. DM61308		DATE 06/14/95	
				ORDER NO.	
				REV. NO. 1	

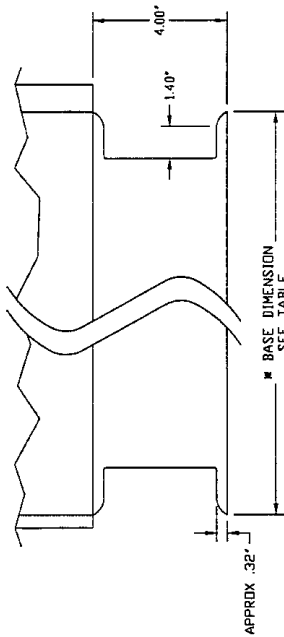
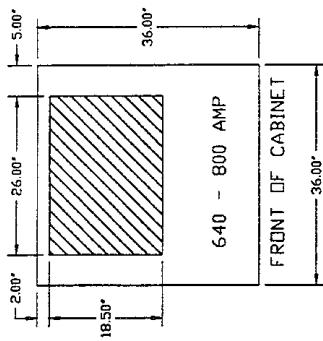
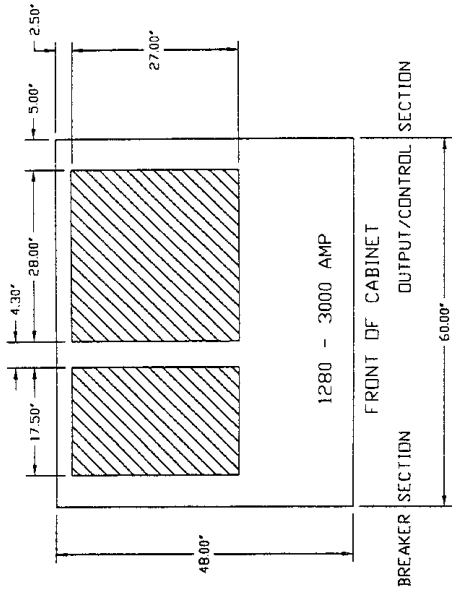
T.E.C. NAME: DM613081.DWG
 IRVINE, CALIFORNIA 92718

Figure 27 Base Mounting Details, 750 kVA (Low Link - 180 Cells) and 1000 kVA, Control Section



DRAWN BY B FISH	SHEET NO 1 OF 1	TITLE BASE MOUNTING DETAILS 750 (LL) AND 1000 KVA SINGLE AND MULTI MODULE CONTROL SECTION SERIES 600	
CHK BY J CAMPBELL	ECN NO	DWG. NO. 88-791613-09	DATE 06/14/95
DES APVL DM61309	REF. DWG. DM61309	REV. NO. 1	ORDER NO.
		 9650 JERONIMO RD. IRVINE, CALIFORNIA 92718	

Figure 28 Base Mounting Patterns, System Control Cabinets (SCCB) 640 to 3000 Amps



BASE CHANNEL DETAIL (FRONT & REAR)
SIDE VIEW

AMP	BASE DEPTH
640 THRU 800	36"
2000 THRU 3000	48"

- NOTES:
1. SHADED AREAS (REMOVABLE PLATES) INDICATE LOCATIONS FOR BOTTOM ENTRY OF CUSTOMER'S CABLES IF DESIRED.
 2. THE REMOVABLE PLATES SHOWN ARE LOCATED APPROXIMATELY 4 INCHES FROM THE CABINET BASE MOUNTING SURFACE (e.g. CONCRETE FLOOR).
 3. TOLERANCE ON ALL DIMENSIONS IS $\pm .25$ "
 4. ALL DIMENSIONS ARE IN INCHES.


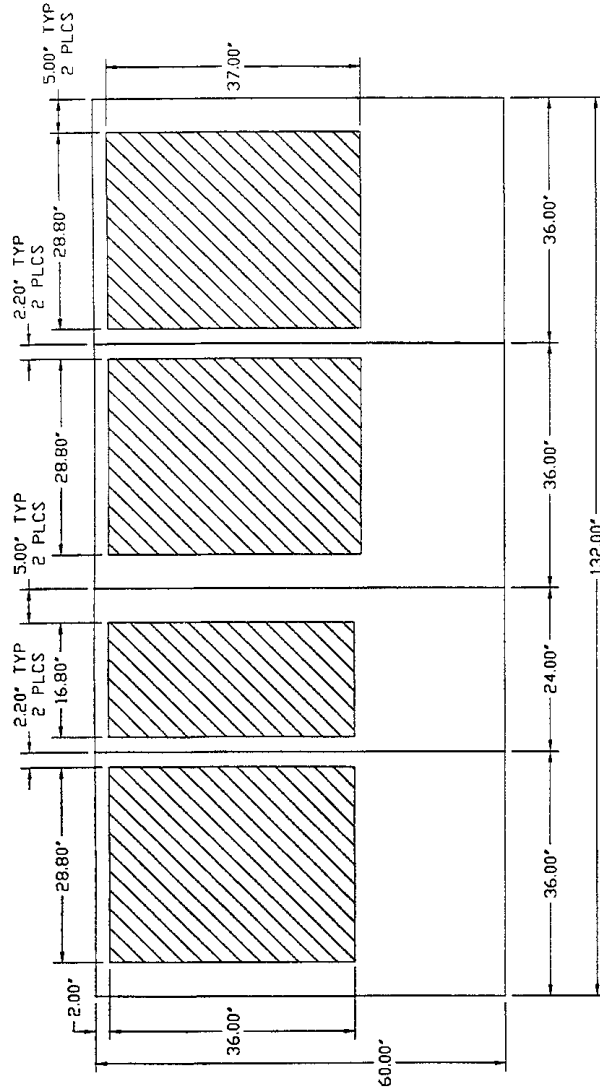
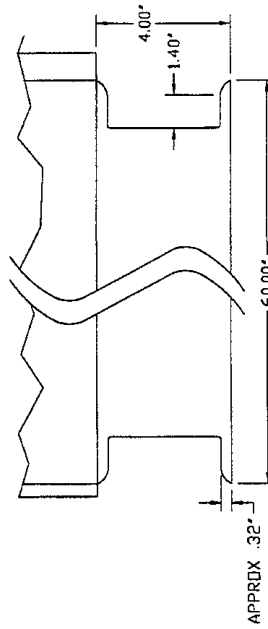
DRAWN BY B. FISH		SHEET NO 1 OF 1		TITLE BASE MOUNTING PATTERNS 640 - 3000 AMP SYSTEM CONTROL CABINETS (SCCB) SERIES 600	
CHK BY J. CAMPBELL		ECN NO		DATE 06/14/95	
DES. APVL		REF. DWG. DM61310		ORDER NO.	
				REV. NO. 1	
				FILE NAME: DM61310.DWG	
				 9650 JERONIMO RD. IRVINE, CALIFORNIA 92718	

Figure 29 Base Mounting Patterns, System Control Cabinets (SCCB) 4000 Amps




FRONT OF CABINET



BASE CHANNEL DETAIL (FRONT & REAR)
SIDE VIEW

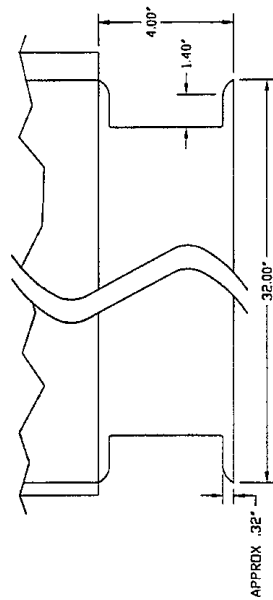
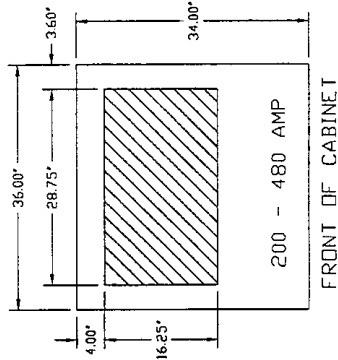
NOTES:

1. SHADED AREAS (REMOVABLE PLATES) INDICATE LOCATIONS FOR BOTTOM ENTRY OF CUSTOMER CABLES IF DESIRED.
2. THE REMOVABLE PLATES SHOWN ARE LOCATED APPROXIMATELY 4 INCHES FROM THE CABINET BASE MOUNTING SURFACE (e.g. CONCRETE FLOOR).
3. TOLERANCE ON ALL DIMENSIONS IS $\pm .25$ "
4. ALL DIMENSIONS ARE IN INCHES.

DRAWN BY B FISH		SHEET NO 1 OF 1		TITLE BASE MOUNTING PATTERNS 4000 AMP SYSTEM CONTROL CABINETS (SCCB) SERIES 600	
CHK BY J CAMPBELL		ECN NO		DWG. NO. 88-791613-11	DATE 06/14/95
DES' APVL		REF. DWG. DM61311		REV. NO. 1	ORDER NO.
 9650 JERONIMO RD. IRVINE, CALIFORNIA 92718					

FILE NAME: DM61311.DWG

Figure 30 Base Mounting Patterns, System Control Cabinets (SCCP) 200 to 480 Amps



BASE CHANNEL DETAIL (FRONT & REAR)
SIDE VIEW

NOTES:

1. SHADED AREAS (REMOVABLE PLATES) INDICATE LOCATIONS FOR BOTTOM ENTRY OF CUSTOMER'S CABLES IF DESIRED.
2. THE REMOVABLE PLATES SHOWN ARE LOCATED APPROXIMATELY 4 INCHES FROM THE CABINET BASE MOUNTING SURFACE (e.g. CONCRETE FLOOR).
3. TOLERANCE ON ALL DIMENSIONS IS $\pm .25$ '
4. ALL DIMENSIONS ARE IN INCHES.


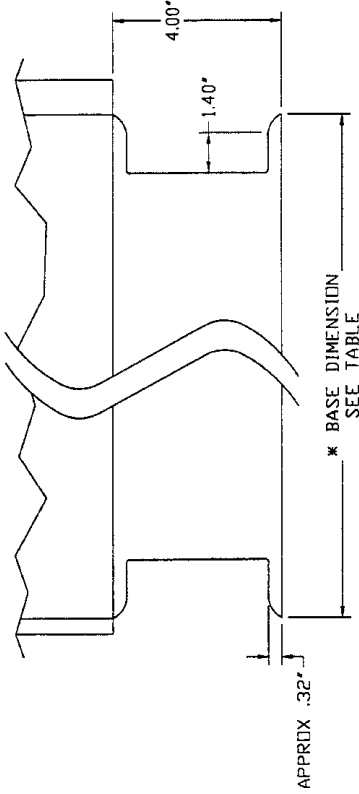
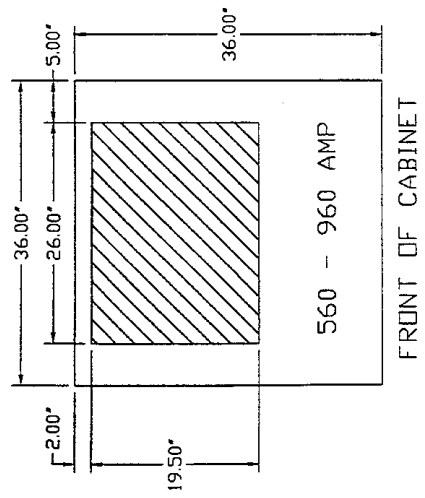
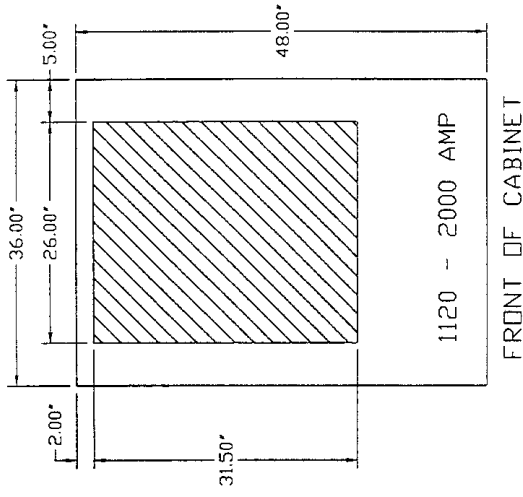
DRAWN BY B FISH	SHEET NO 1 OF 1	TITLE BASE MOUNTING PATTERNS 200 - 480 AMP SYSTEM CONTROL CABINETS (SCCB) SERIES 600		DWG. NO. 88-791613-12	DATE 06/14/95
CHK BY J CAMPBELL	ECN NO			REV. NO. 1	ORDER NO.
DES APVL	REF. DWG. DM61312			FILE NAME: DM61312.DWG	
				 9650 JERONIMO RD. IRVINE, CALIFORNIA 92718	

Figure 31 Base Mounting Patterns, System Control Cabinets (SCCP) 560 to 2000 Amps




BASE CHANNEL DETAIL (FRONT & REAR)
SIDE VIEW

AMP	BASE DEPTH
560 THRU 960	36"
1120 THRU 2000	48"

- NOTES:
1. SHADED AREAS (REMOVABLE PLATES) INDICATE LOCATIONS FOR BOTTOM ENTRY OF CUSTOMER'S CABLES IF DESIRED.
 2. THE REMOVABLE PLATES SHOWN ARE LOCATED APPROXIMATELY 4 INCHES FROM THE CABINET BASE MOUNTING SURFACE (e.g. CONCRETE FLOOR).
 3. TOLERANCE ON ALL DIMENSIONS IS $\pm .25$ "
 4. ALL DIMENSIONS ARE IN INCHES.

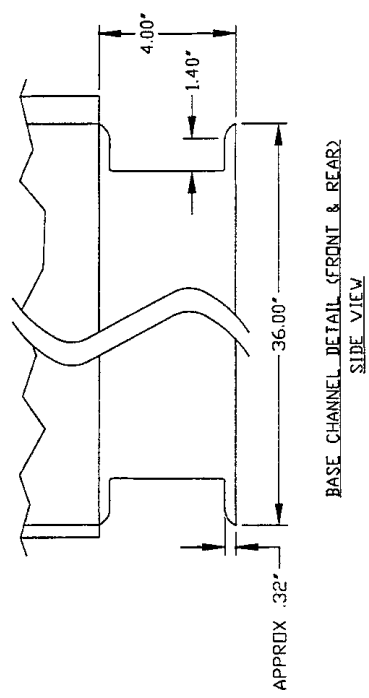
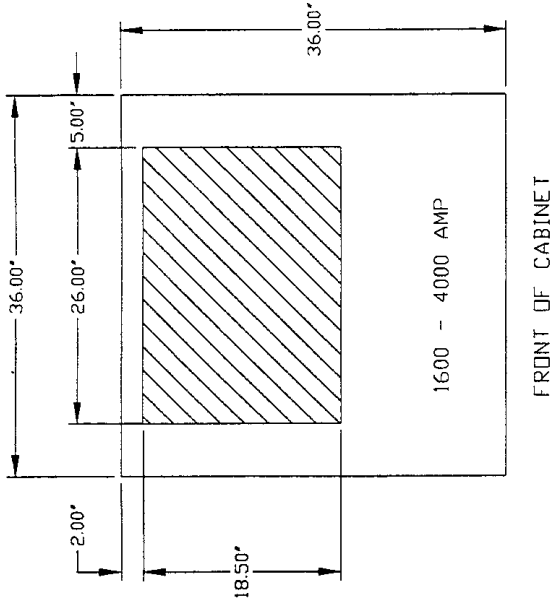
DRAWN BY B FISH	SHEET NO 1 OF 1	TITLE BASE MOUNTING PATTERNS 560 - 2000 AMP SYSTEM CONTROL CABINETS (SCCB) SERIES 600	
	CHK BY J CAMPBELL	ECN NO	DWG. NO. 88-791613-13
DES' APVL	REF. DWG. DM61313	DATE 06/14/95	ORDER NO.




 9650 JERONIMO RD.
 IRVINE, CALIFORNIA 92718

FILE NAME: DM61313.DWG

Figure 32 Base Mounting Patterns, System Control Cabinets (SCCA) 1600 to 4000 Amps

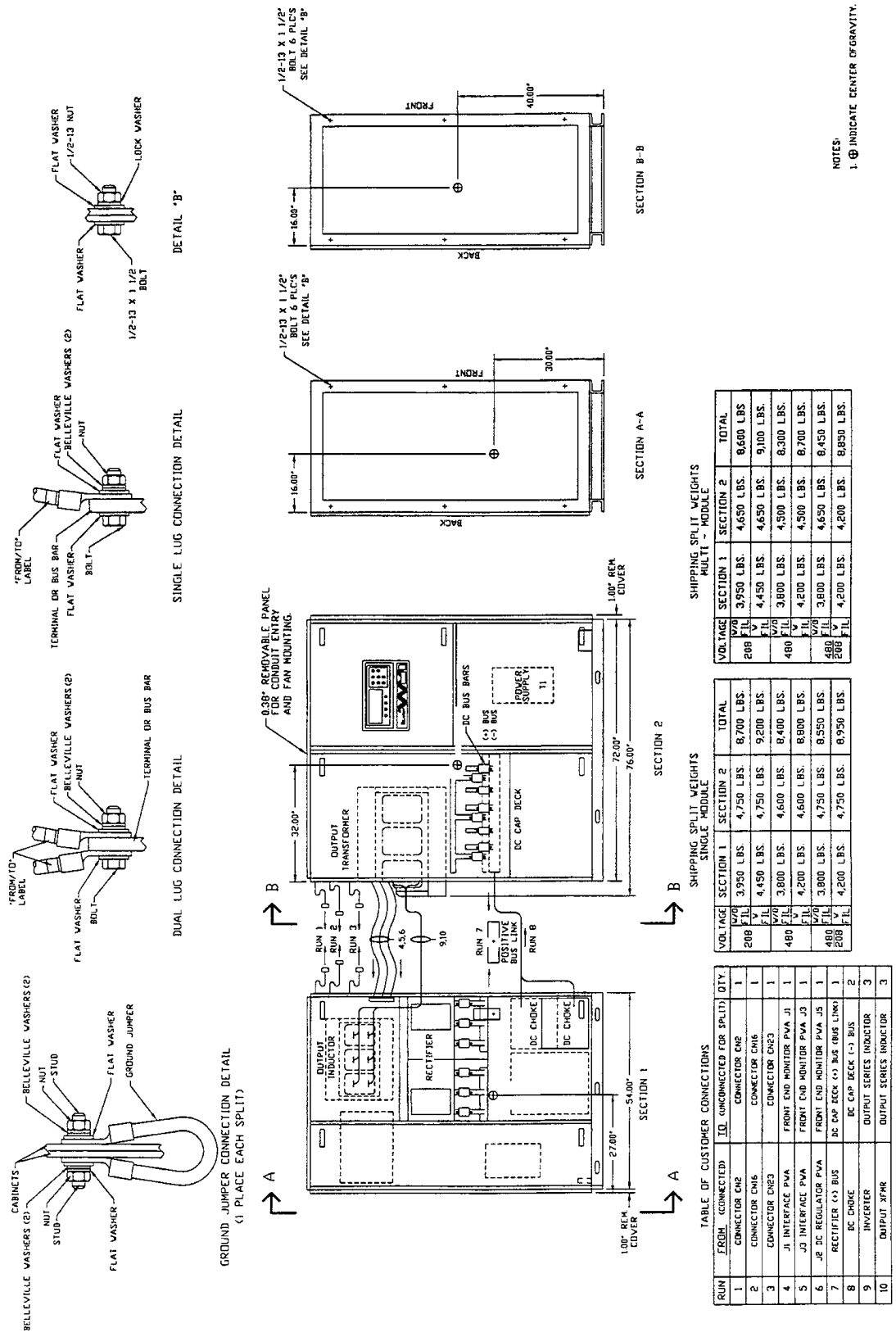


- NOTES:
1. SHADED AREAS (REMOVABLE PLATES) INDICATE LOCATIONS FOR BOTTOM ENTRY OF CUSTOMER'S CABLES IF DESIRED.
 2. THE REMOVABLE PLATES SHOWN ARE LOCATED APPROXIMATELY 4 INCHES FROM THE CABINET BASE MOUNTING SURFACE (e.g. CONCRETE FLOOR).
 3. TOLERANCE ON ALL DIMENSIONS IS $\pm .25$.
 4. ALL DIMENSIONS ARE IN INCHES.

DRAWN BY B. FISH	SHEET NO 1 OF 1	TITLE BASE MOUNTING PATTERNS 1600 - 4000 AMP SYSTEM CONTROL CABINETS (SCCB) SERIES 600	DWG. NO. 88-791613-14	DATE 06/14/95
CHK BY J. CAMPBELL	ECN NO		REV. NO. 1	ORDER NO.
DES. APVL	REF. DWG. DW61314		 9650 FERONIMO RD. IRVINE, CALIFORNIA 92718	

FILE NAME: DR651413.DWG

Figure 33 Shipping Split Detail, 338 kVA



NOTES:
1. ⊕ INDICATE CENTER OF GRAVITY.


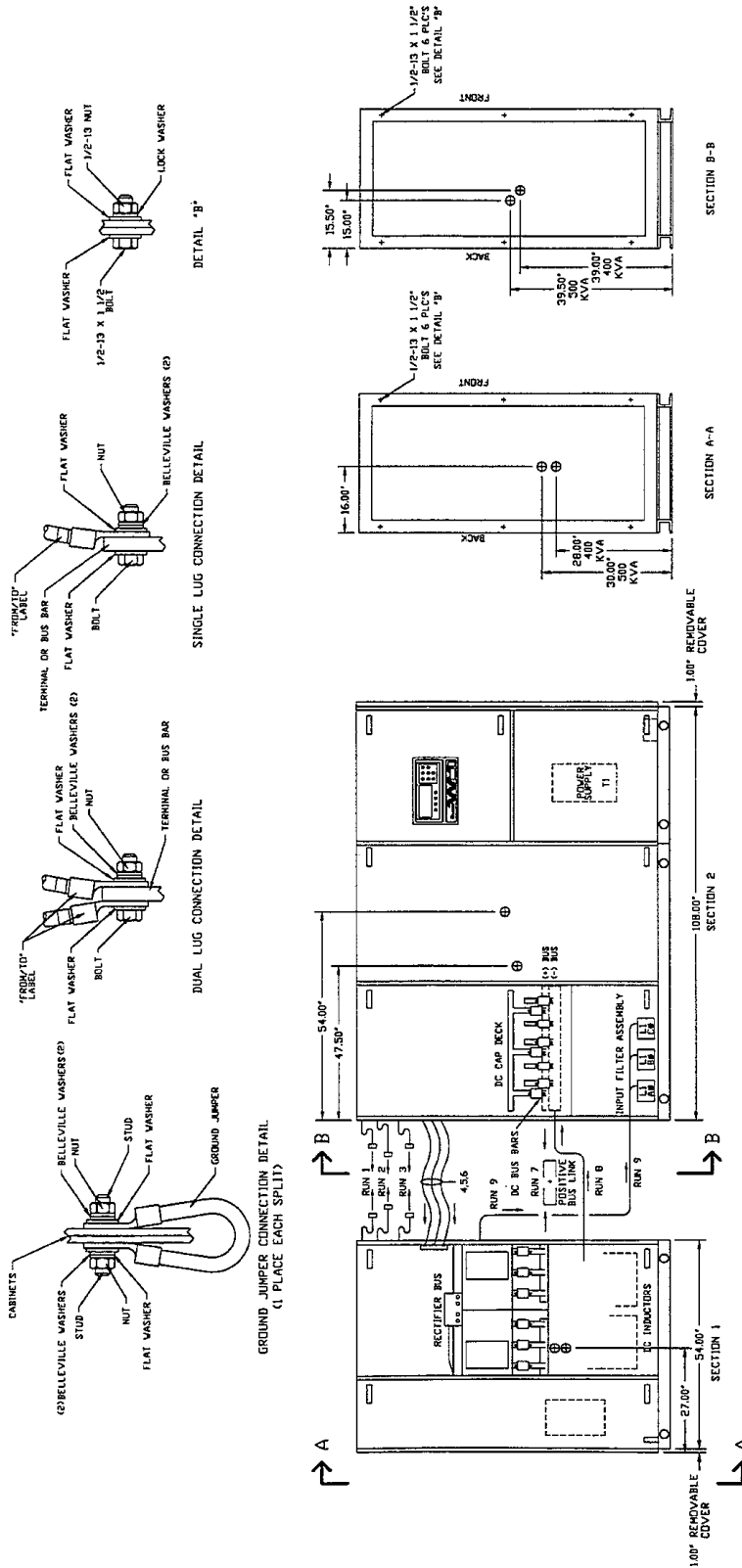
DRAWN BY B FISH		SHEET NO 1 OF 1	
CHK BY J CAMPBELL		ECN NO	
DES APVL		REF. DWG. SS61201	
SHIPPING SPLIT DETAIL 338 KVA SINGLE & MULTI MODULE UPS SERIES 600			
DWG. NO. 88-791612-01		DATE 06/12/95	
REV. NO. 1		ORDER NO.	
 9650 JERDING RD. IRVINE, CALIFORNIA 92718			

Figure 34 Shipping Split Detail, 400 and 500 kVA



SHIPPING SPLIT WEIGHTS

KVA	SECTION 1	SECTION 2	TOTAL
400	4,000 LBS.	5,900 LBS.	9,900 LBS.
500	4,250 LBS.	6,050 LBS.	10,300 LBS.

KVA	SECTION 1	SECTION 2	TOTAL
400	4,150 LBS.	6,450 LBS.	10,600 LBS.
500	4,500 LBS.	6,650 LBS.	11,150 LBS.

TABLE OF CUSTOMER CONNECTIONS

RUN	REQ'D	CONNECTED	UNCONNECTED FOR SPLIT	QTY.
1	CONNECTOR CNE	CONNECTOR CNE	CONNECTOR CNE	1
2	CONNECTOR CNE	CONNECTOR CNE	CONNECTOR CNE	1
3	CONNECTOR CNE	CONNECTOR CNE	CONNECTOR CNE	1
4	RIBBON CABLE 5	FRONT END MONITOR PWA	FRONT END MONITOR PWA	1
5	RIBBON CABLE 7	FRONT END MONITOR PWA	FRONT END MONITOR PWA	1
6	RIBBON CABLE 9	FRONT END MONITOR PWA	FRONT END MONITOR PWA	1
7	RECTIFIER C-3 BUS (BUS LING)	DC CAP INDUCTOR C-3 BUS	DC CAP INDUCTOR C-3 BUS	4
8	DC CHOKE	DC CAP INDUCTOR C-3 BUS	DC CAP INDUCTOR C-3 BUS	4
9	L1, L2, L3, R1, R2, R3	INPUT FILTER ASSEMBLY	INPUT FILTER ASSEMBLY	3

* RUN 9 IS REQUIRED FOR UPS MODULES WHICH INCLUDE OPTIONAL HARMONIC DISTORTION INPUT FILTERS.

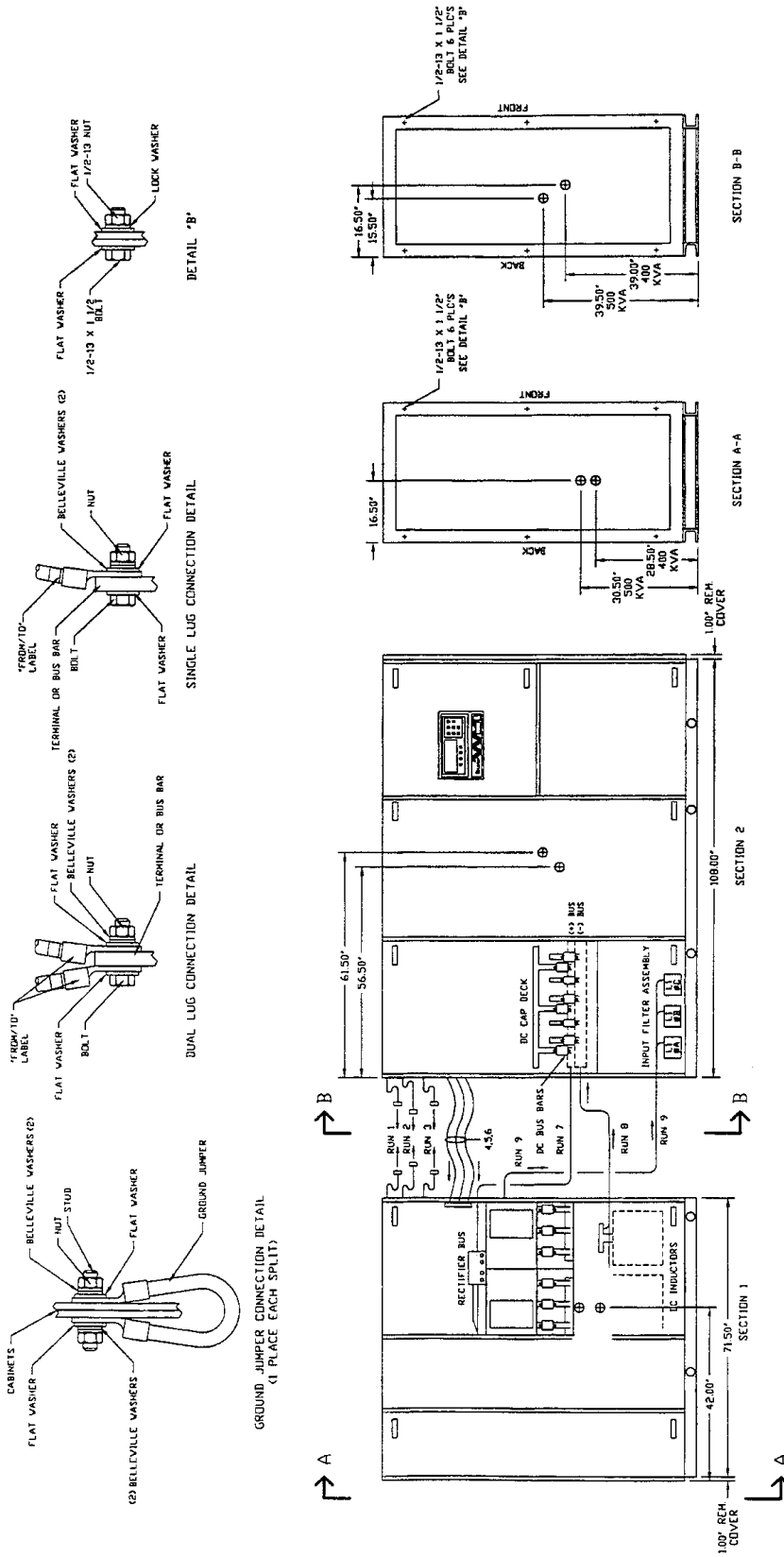
NOTES:
1. ⊕ INDICATE CENTER OF GRAVITY

DRAWN BY B FISH		SHEET NO 1 OF 1		TITLE SHIPPING SPLIT DETAIL 400 AND 500 KVA MULTI-MODULE UPS 480V AND 600V SERIES 600	
CHK BY J CAMPBELL		ECN NO		DWG. NO. 88-791612-04	
DES APVL SS61204		REF. DWG.		ORDER NO.	
		DATE 06/12/95		REV. NO. 1	

FILE NAME: SSG6R1204.DWG



Figure 35 Shipping Split Detail, 400 and 500 kVA, 208 VAC



SHIPPING SPLIT WEIGHTS
MULTI - MODULE

KVA	SECTION 1	SECTION 2	TOTAL
400	4,350 LBS.	5,900 LBS.	10,250 LBS.
	FTL	6,050 LBS.	10,750 LBS.
500	4,500 LBS.	6,450 LBS.	10,950 LBS.
	FTL	5,000 LBS.	11,650 LBS.

RUN	FROM (CONNECTED)	TO (CONNECTED FOR SPLIT)	QTY
1	CONNECTOR ENG	CONNECTOR ENG	1
2	CONNECTOR ENG	CONNECTOR ENG	1
3	CONNECTOR ENG	CONNECTOR ENG	1
4	INTERFACE PVA J1	FRONT END MONITOR PVA J1	1
5	INTERFACE PVA J3	FRONT END MONITOR PVA J3	1
6	DC REGULATOR PVA J2	FRONT END MONITOR PVA J2	1
7	RECTIFIER C-3 BUS	DC CAP DECK C-3 BUS LINE	4
8	DC CHARGE	DC CAP DECK C-3 BUS	4
8.9	LI, L&L / M, K2, X3	INPUT FILTER ASSEMBLY OF PVA J4	3

* RUN 9 IS REQUIRED FOR UPS MODULES WHICH INCLUDE OPTIONAL HARMONIC DISTORTION INPUT FILTERS.

NOTES
1. ⊕ INDICATE CENTER OF GRAVITY.



9450 JEROME RD.
IRVINE, CALIFORNIA 92718

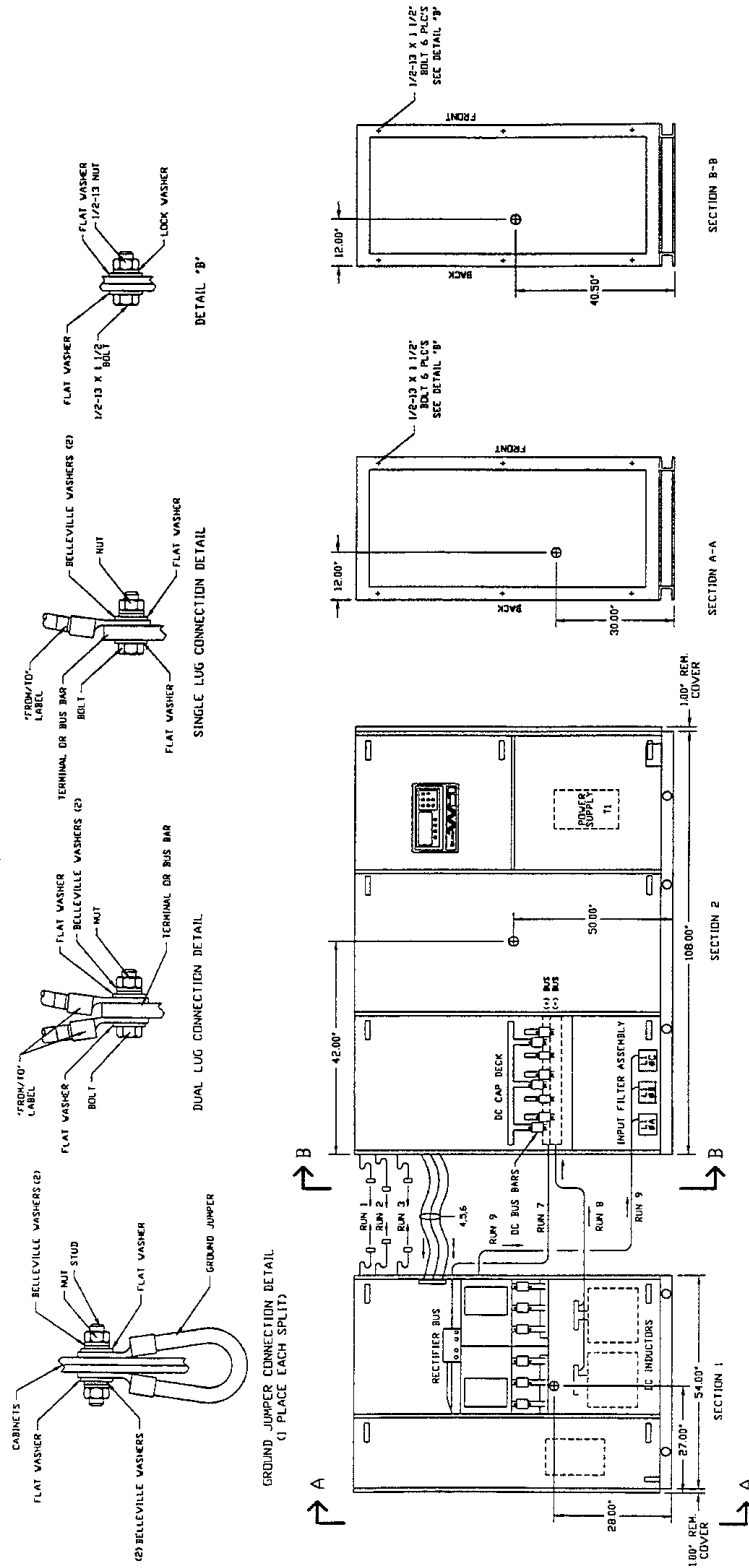
DWG. NO.	DATE
88-791612-06	06/13/95
REV. NO.	ORDER NO.
1	

SHIPPING SPLIT DETAIL
400 AND 500 KVA
MULTI-MODULE UPS
208 V INPUT - 208 / 120 V OUTPUT
SERIES 600

DRAWN BY	SHEET NO	TITLE
B FISH	1 OF 1	
CHK BY	ECN NO	
J CAMPBELL		
DES APVL	REF. DWG.	
	SS61206	

FILE NAME: SS61206.DWG

Figure 36 Shipping Split Detail, 625 kVA



SHIPPING SPLIT WEIGHTS
SINGLE MODULE

KVA	SECTION 1	SECTION 2	TOTAL
625	4,500 LBS.	8,000 LBS.	12,500 LBS.
	4,900 LBS.	8,250 LBS.	13,150 LBS.

SHIPPING SPLIT WEIGHTS
MULTI - MODULE

KVA	SECTION 1	SECTION 2	TOTAL
625	4,500 LBS.	7,800 LBS.	12,300 LBS.
	4,900 LBS.	8,050 LBS.	12,950 LBS.

TABLE OF CUSTOMER CONNECTIONS

RUN	FROM CONNECTED	ID.	UNCONNECTED FOR SPLIT	QTY.
1	CONNECTOR CNE		CONNECTOR CNE	1
2	CONNECTOR CNE		CONNECTOR CNE	1
3	CONNECTOR CNE		CONNECTOR CNE	1
4	INTERFACE PVA		FRONT END MONITOR PVA J1	1
5	INTERFACE PVA		FRONT END MONITOR PVA J2	1
6	DC REGULATOR PVA		FRONT END MONITOR PVA J2	1
7	RECTIFIER C-BUS		DC CAP DECK C-BUS BRK CNE	4
8	DC CHARGE		DC CAP DECK C-BUS BRK CNE	4
9	LINE IN / XL IN / 33 OPT1		2X TRAP ASST. L1 OF PVA, PVA J3	3

* RUN 9 IS REQUIRED FOR UPS MODULES WHICH INCLUDE OPTIONAL HARMONIC DISTORTION INPUT FILTERS.

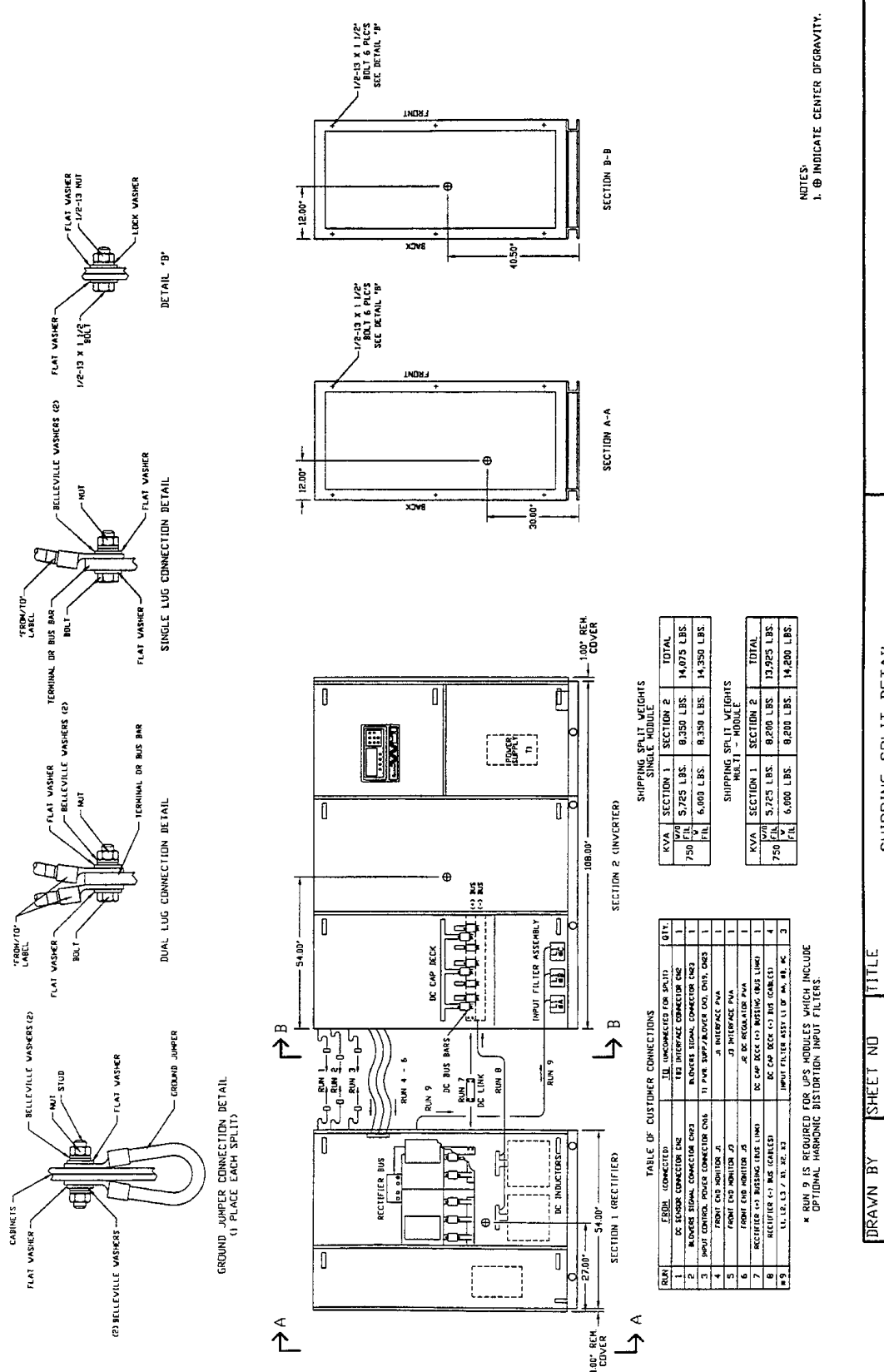
NOTES:
1. ⊕ INDICATE CENTER OF GRAVITY.

DRAWN BY B FISH	SHEET NO 1 OF 1	TITLE SHIPPING SPLIT DETAIL 625 KVA SINGLE AND MULTI MODULE UPS SERIES 600	DWG. NO. 88-791612-07	DATE 06/13/95
	CHK BY J CAMPBELL		ECN NO	REV. NO. 1
DES APVL SS61207	REF. DWG. SS61207			



FILE NAME: SS6071.DWG

Figure 37 Shipping Split Detail, 750 kVA (High Link - 240 Cells)



NOTES:
1. ⊕ INDICATE CENTER OF GRAVITY.

SHIPPING SPLIT WEIGHTS

KVA	SECTION 1		SECTION 2		TOTAL
	W	FIL	W	FIL	
750	5,725	6,000	8,350	8,350	14,075
750	5,725	6,000	8,200	8,200	13,925

SHIPPING SPLIT WEIGHTS MULTI-MODULE

KVA	SECTION 1		SECTION 2		TOTAL
	W	FIL	W	FIL	
750	5,725	6,000	8,200	8,200	13,925
750	5,725	6,000	8,200	8,200	13,925

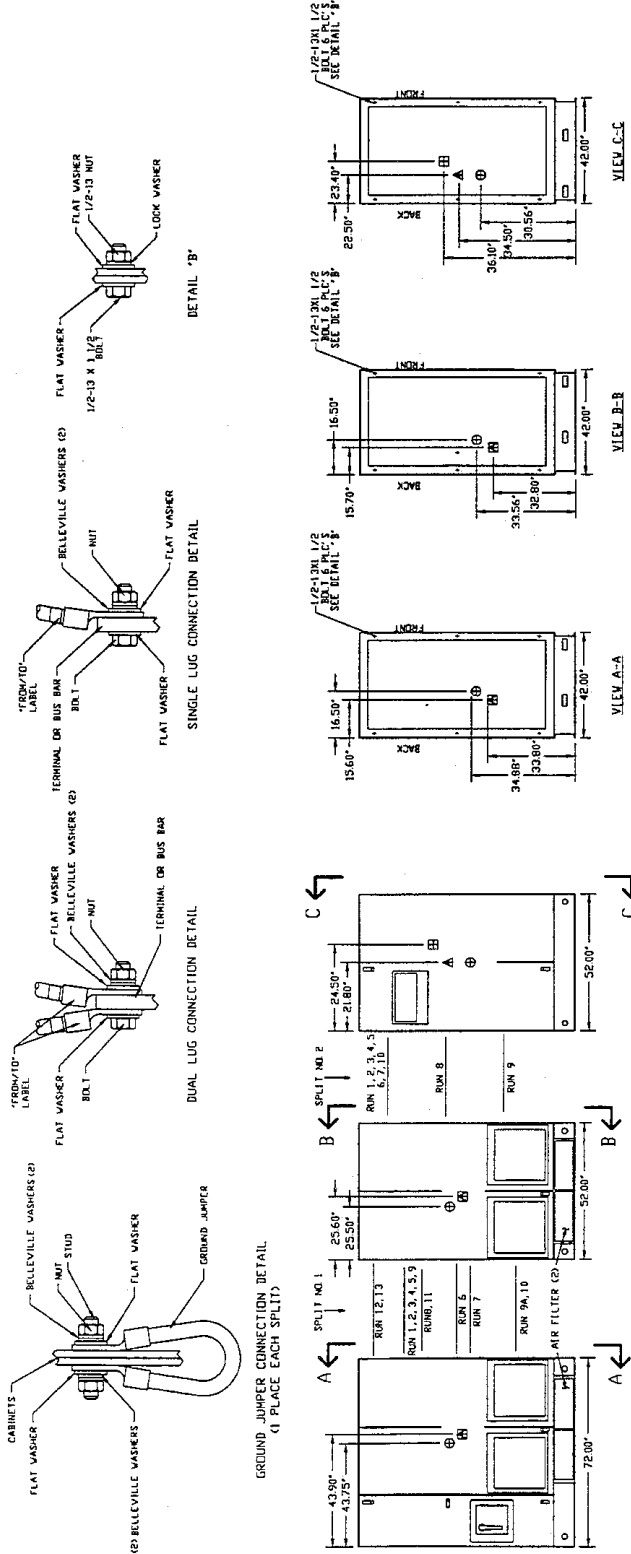
TABLE OF CUSTOMER CONNECTIONS

RUN	DESCRIPTION	QTY.
1	DC BATTERY CONNECTOR CABLE	1
2	DC BATTERY SIGNAL CONNECTOR CABLE	1
3	INPUT CONTROL POWER CONNECTOR CABLE	1
4	FRONT END MONITOR 'A'	1
5	FRONT END MONITOR 'B'	1
6	RECTIFIER (1) BUSHING (105 LHM)	1
7	RECTIFIER (1) BUS (105 LHM)	1
8	DC CAP DECK (1) BUS (105 LHM)	1
9	INPUT FILTER ASSEMBLY (1) BUS (105 LHM)	1

* RUN 9 IS REQUIRED FOR UPS MODULES WHICH INCLUDE OPTIONAL HARMONIC DISTORTION INPUT FILTERS.

DRAWN BY B FISH		SHEET NO 1 OF 1		TITLE SHIPPING SPLIT DETAIL	
CHK BY J CAMPBELL		ECN NO		750 KVA - 240 CELL	
DES APVL		REF. DWG. SS61208		SINGLE AND MULTI MODULE UPS	
DWG. NO. 88-791612-08		DATE 06/13/95		SERIES 600	
REV. NO. 1		ORDER NO.		LIBERT	
FILE NAME: SS61208.DWG				9650 JERONIMO RD. IRVINE, CALIFORNIA 92718	

Figure 38 Shipping Split Detail, 750 kVA (Low Link - 180 Cells) and 1000 kVA



750 KVA 180 CELL

FRONT ACCESS	SECTION 1	SECTION 2	SECTION 3	TOTAL
SIZE	7,100	7,800	1,500	15,600
WTH FLTR	6,150	7,000	1,475	14,750
WTH PMA	7,100	7,000	1,500	15,600
WTH INVT	6,250	7,000	1,350	14,600

1000 KVA

FRONT ACCESS	SECTION 1	SECTION 2	SECTION 3	TOTAL
SIZE	8,150	7,900	1,500	17,550
WTH FLTR	7,300	7,900	1,500	16,700
WTH PMA	8,150	7,900	1,500	17,550
WTH INVT	7,300	7,900	1,350	16,550

WEIGHS IN LBS

NOTES:

- RUN B AND 11 MUST PASS THROUGH THE SAME OPENING AT THE SPLIT.
- REMOVE THE AIR FILTER ASSEMBLY TO PREPARE FOR BASE MOUNTING. MAKE SURE THE AIR FILTER UNIT IS INSTALLED AT SITE.
- FOR BASE MOUNTING DETAILS AND LIFTING INSTRUCTIONS, SEE DDG 88-791613-18.

SHIPPING SPLIT NO. 2

RUN	FROM CONNECTED	TO DISCONNECTED	QTY
1	CHMS	TO DISCONNECTED	1
2	DC SENSOR PMA TER	INTERFACE PMA TER	2
3	FRONT END MONITOR J1	INTERFACE PMA J1	1
4	FRONT END MONITOR J2	INTERFACE PMA J2	1
5	FRONT END MONITOR J3	INTERFACE PMA J3	1
6	DC REGULATOR PMA J1	DC REGULATOR J1	1
7	DC REGULATOR PMA J2	INTERFACE PMA J2	1
8	DC REGULATOR PMA J3	INTERFACE PMA J3	1
9	OUTPUT TRANSFORMER	OUTPUT TRANSFORMER (E. NEUTRAL)	4
10	DC CONVERTER J1	DC REGULATOR J1	1

SHIPPING SPLIT NO. 1

RUN	FROM CONNECTED	TO DISCONNECTED	QTY
1	CHMS	TO DISCONNECTED	1
2	DC SENSOR PMA TER	INTERFACE PMA TER	2
3	FRONT END MONITOR J1	INTERFACE PMA J1	1
4	FRONT END MONITOR J2	INTERFACE PMA J2	1
5	FRONT END MONITOR J3	INTERFACE PMA J3	1
6	DC REGULATOR PMA J1	DC REGULATOR J1	1
7	DC REGULATOR PMA J2	INTERFACE PMA J2	1
8	DC REGULATOR PMA J3	INTERFACE PMA J3	1
9	OUTPUT TRANSFORMER	OUTPUT TRANSFORMER (E. NEUTRAL)	4
10	DC CONVERTER J1	DC REGULATOR J1	1

CENTER OF GRAVITY KEY

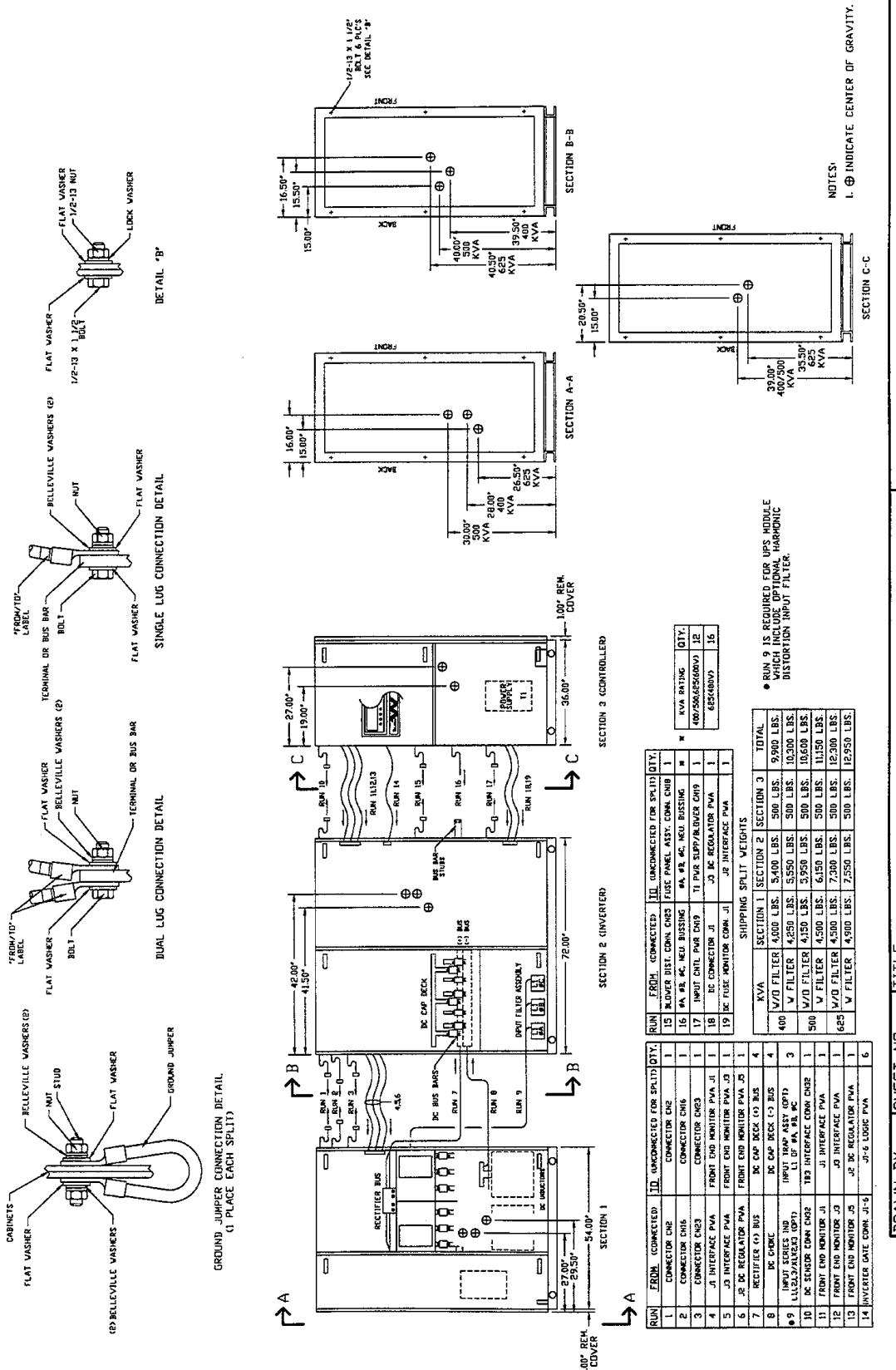
- ⊖ - 750 KVA 180 CELL
- ⊕ - 1000 KVA SINGLE MODULE
- ⊙ - 1000 KVA MULTI-MODULE

DRAWN BY B FISH		SHEET NO 1 OF 1		TITLE SHIPPING SPLIT DETAIL 750 KVA - 180 CELL SINGLE AND MULTI MODULE UPS SERIES 600	
CHK BY J CAMPBELL		EON NO		DWG. NO. 88-791612-09	
DES APVL SS61209		REF. DWG.		REV. NO. 1	
				DATE 06/13/95	
				ORDER NO.	

FILE NAME: SS61209.DWG

Libert
9650 FERDINAND RD.
IRVINE, CALIFORNIA 92718

Figure 39 Optional Shipping Split Detail, 400 to 625 kVA



NOTES:
1. ⊕ INDICATE CENTER OF GRAVITY.



DATE 06/13/95
ORDER NO.
REV. NO. 1

DWG. NO. 88-791612-11
REV. NO. 1

SHIPPING SPLIT DETAIL
400, 500 AND 625 KVA
MULTI-MODULE UPS
WITH OPTIONAL 2ND SHIPPING SPLIT
480V AND 600V INPUT
SERIES 600

DRAWN BY SHEET NO
B FISH 1 OF 1
CHK BY ECN NO
J CAMPBELL
DES APVL REF. DWG.
SS61211

IRVINE, CALIFORNIA 92718

FILE NAME: SSG61211.DWG

RUN	FROM	CONNECTED	UNCONNECTED FOR SPLIT	QTY.
15	BLUVER DIST. CONN. CHG	FUSE PANEL ASSY. CONN. CHG	1	
16	PA. RE. AC. NEU. BUSSING	PA. RE. AC. NEU. BUSSING	M	
17	INPUT CHIL. PWR. CHG	TI PWR. SUPP./BLUVER CHG	1	
18	DC CONNECTOR JI	JI DC REGULATOR PWA	1	
19	DC FUSE MONITOR CONN. JI	JI INTERFACE PWA	1	

SHIP. SPLIT WEIGHTS	SECTION 1	SECTION 2	SECTION 3	TOTAL
400	W/O FILTER: 4,000 LBS.	5,400 LBS.	500 LBS.	9,900 LBS.
400	W/FILTER: 4,250 LBS.	5,550 LBS.	500 LBS.	10,300 LBS.
500	W/O FILTER: 4,150 LBS.	5,950 LBS.	500 LBS.	10,600 LBS.
500	W/FILTER: 4,500 LBS.	6,150 LBS.	500 LBS.	11,150 LBS.
625	W/O FILTER: 4,500 LBS.	7,300 LBS.	500 LBS.	12,300 LBS.
625	W/FILTER: 4,900 LBS.	7,550 LBS.	500 LBS.	12,950 LBS.

* RUN 9 IS REQUIRED FOR UPS MODULE WHICH INCLUDE OPTIONAL HARMONIC DISTORTION INPUT FILTER.

Figure 40 Optional Shipping Split Detail, 750 kVA

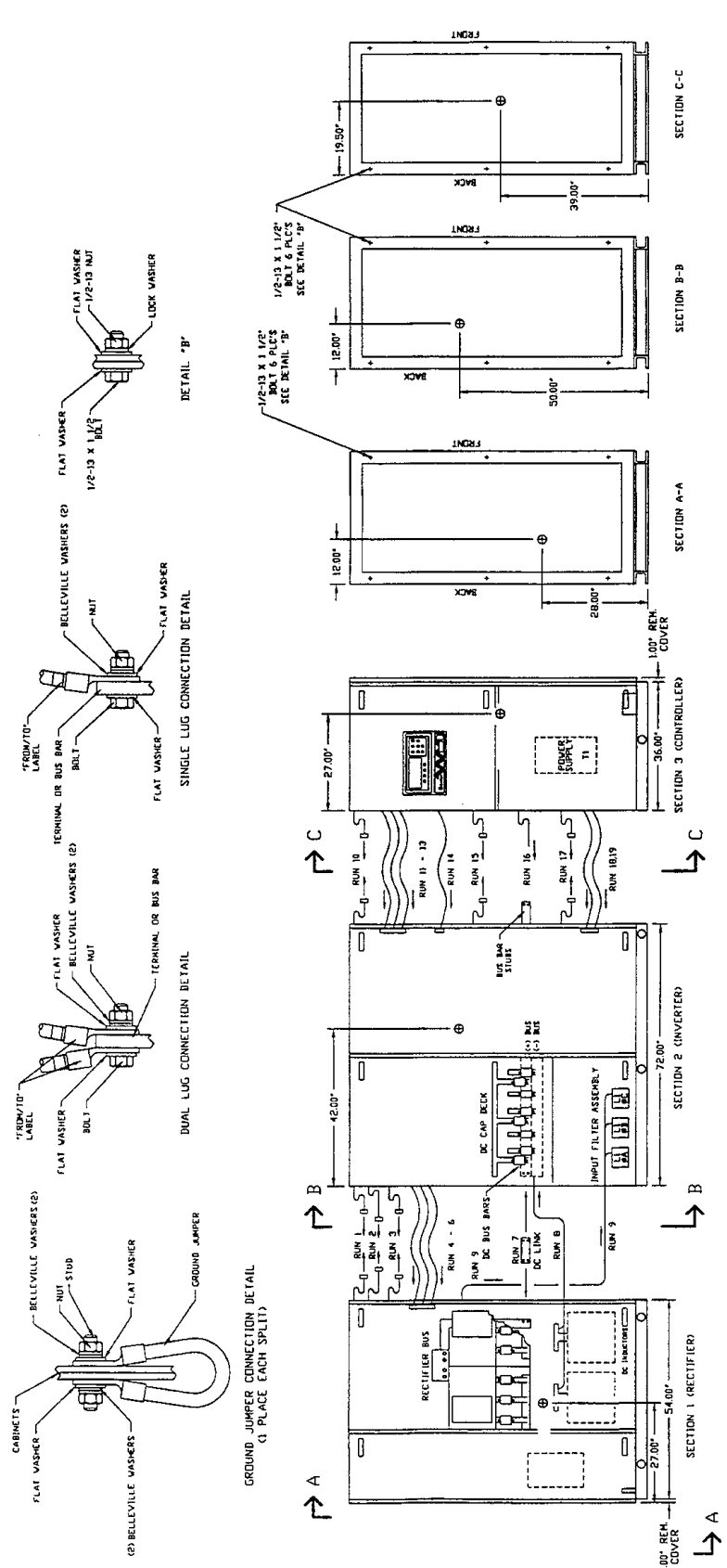


TABLE OF CUSTOMER CONNECTIONS

RUN	FROM	TO	CONNECTED	UNCONNECTED FOR SPLIT	QTY.
1	CONNECTOR CHB	CONNECTOR CHB	✓		1
2	CONNECTOR CHB	CONNECTOR CHB	✓		1
3	CONNECTOR CHB	CONNECTOR CHB	✓		1
4	J1 INTERFACE PVA	FRONT END MONITOR PVA J1	✓		1
5	J1 INTERFACE PVA	FRONT END MONITOR PVA J5	✓		1
6	J2 REGULATOR PVA	DC CAP DECK C-3 BUS	✓		4
7	RECTIFIER C-3 BUS	DC CAP DECK C-3 BUS	✓		4
8	DC CHARGE	DC CAP DECK C-3 BUS	✓		3
9	L1, L2, L3 / XL, XL3	INPUT FILTER ASST. LI OF PA, PA, DC	✓		3
10	DC SENSOR CONN. CHB	DC INTERFACE CONN. CHB	✓		1
11	FRONT END MONITOR J1	J1 INTERFACE PVA	✓		1
12	FRONT END MONITOR J5	J5 INTERFACE PVA	✓		1
13	INVERTER GATE CONN. 5-6	J1-5 LOGIC PVA	✓		1
14	INVERTER GATE CONN. 5-6	J1-5 LOGIC PVA	✓		1
15	BELEVEUSE DIST. CONN. CHB	FUSE PANEL ASST. CONN. CHB	✓		1
16	PA, PB, PC, NEUT. BUSSING	PA, PB, PC, NEUT. BUSSING	✓		3 PHASE, 3 FOR NEUT.
16A	PA, PB, PC, NEUT. BUSSING	PA, PB, PC, NEUT. BUSSING	✓		4
16B	NEUT. BUS	PRELONG ASST. CHB	✓		1 FOR SHS ONLY
16C	NEUT. BUS	CHB	✓		1 FOR SHS ONLY
17	INPUT CHG. PWR. CONN. J1	J1 PWR SUPP. / BUDGER CHG	✓		1
18	DC CONNECTOR J1	J2 DC REGULATOR PVA	✓		1
19	DC FUSE MONITOR CONN. J1	J2 INTERFACE PVA	✓		1

SHIPPING SPLIT WEIGHTS SINGLE MODULE

KVA	SECTION 1	SECTION 2	SECTION 3	TOTAL
750	5,725 LBS.	7,700 LBS.	650 LBS.	14,075 LBS.
750	6,000 LBS.	7,700 LBS.	650 LBS.	14,350 LBS.
FIL				

SHIPPING SPLIT WEIGHTS MULTI - MODULE

KVA	SECTION 1	SECTION 2	SECTION 3	TOTAL
750	3,725 LBS.	7,700 LBS.	500 LBS.	13,925 LBS.
750	6,000 LBS.	7,700 LBS.	500 LBS.	14,200 LBS.
FIL				

NOTES:

- ⊕ INDICATE CENTER OF GRAVITY.
- RUN 9 IS REQUIRED FOR UPS MODULES HANGING DISTORTION INPUT FILTER.

SHIPPING SPLIT DETAIL
 750 KVA - 240 CELL
 SINGLE AND MULTI MODULE UPS
 WITH OPTIONAL 2ND SHIPPING SPLIT
 SERIES 600

DRAWN BY: B FISH
 CHK BY: J CAMPBELL
 DES: APVL

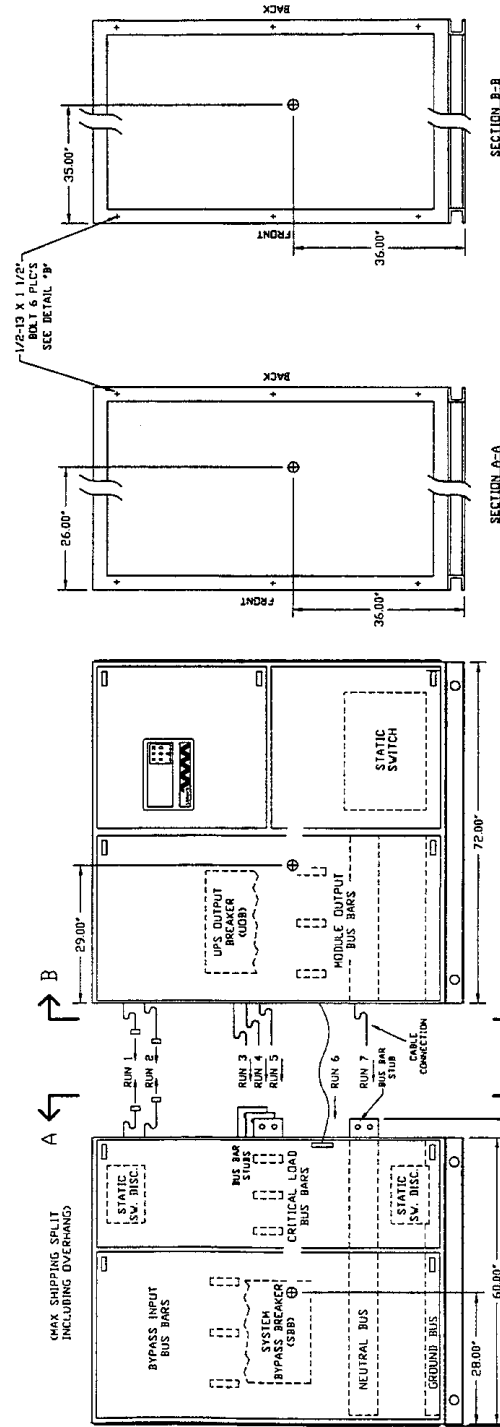
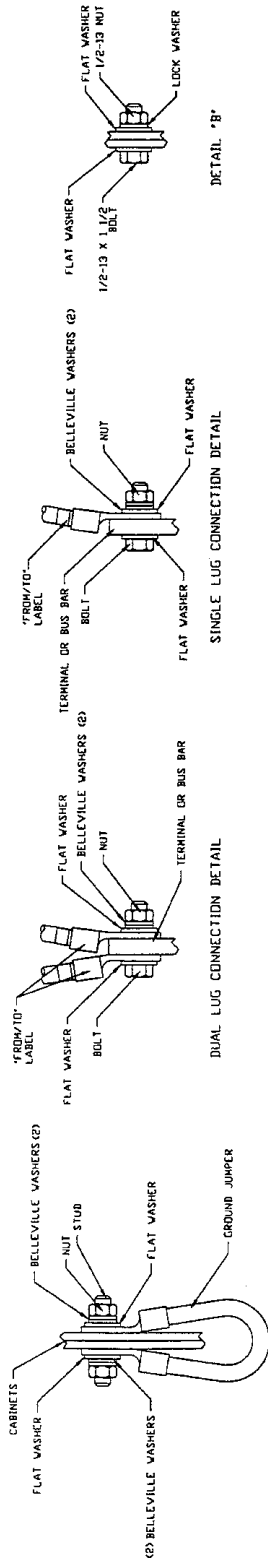
SHEET NO: 1 OF 1
 ECN NO:
 REF. DWG: SS61212

DWG. NO.: 88-791612-12
 REV. NO.: 1
 DATE: 06/13/95
 ORDER NO.:

Libert
 9650 JERONIMO RD.
 IRVINE, CALIFORNIA 92718

FILE NAME: SS61212.DWG

Figure 41 Optional Shipping Split Detail, System Control Cabinet (SCCA) 4000 Amps



RUN	FROM	CONNECTED	ID. (UNCONNECTED FOR SPLIT)	QTY.
1	CONNECTOR CHA3	CONNECTOR CHA3		1
2	CONNECTOR CHA4	CONNECTOR CHA4		1
3	A# BUS BAR STUB	A# CABLE CONNECTION		1
4	B# BUS BAR STUB	B# CABLE CONNECTION		1
5	C# BUS BAR STUB	C# CABLE CONNECTION		1
6	STATIC SWITCH	TRANSFER RELAY PVA		1
7	NEUTRAL BUS BAR STUB	NEUTRAL BUS BAR		4

SHIPPING SPLIT WEIGHTS		
SECTION 1	SECTION 2	TOTAL
2,555 LBS	2,325 LBS	4,880 LBS

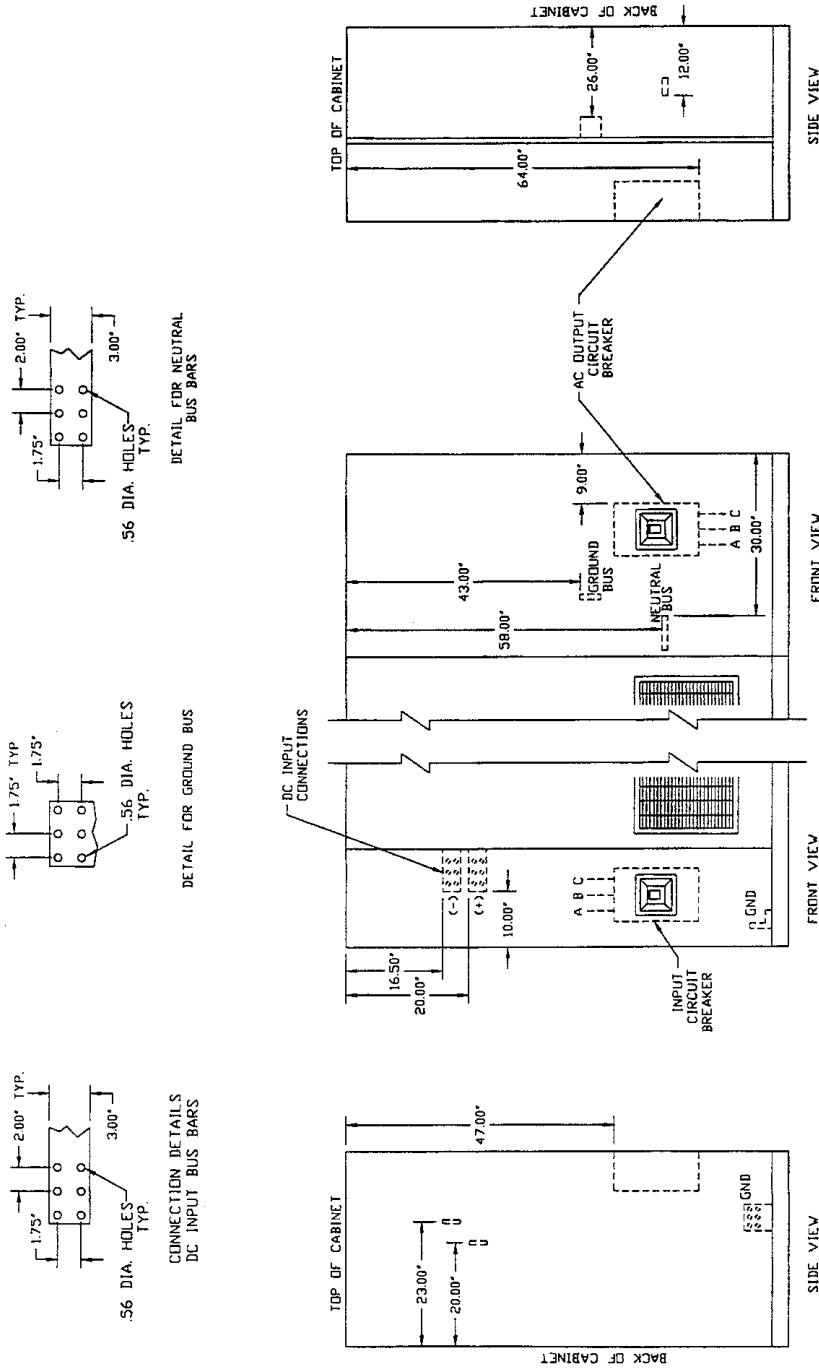
NOTES:
1. Ⓢ INDICATE CENTER OF GRAVITY.

DRAWN BY B FISH		SHEET NO 1 OF 1		TITLE SHIPPING SPLIT DETAIL 4000 AMP SYSTEM CONTROL CABINET (SCCB) SERIES 600	
CHK BY J CAMPBELL		ECN NO		DWG. NO. 88-791612-13	DATE 06/13/95
DES APVL		REF. DWG. SS61213		REV. NO. 1	ORDER NO.

9650 JERKINING RD.
 IRVINE, CALIFORNIA 92719

FILE NAME: SS61213.DWG

Figure 42 Bussing Details, 338 kVA



- NOTES:
1. FOR CONNECTION TO BUS BARS, LUGS TO BE PROVIDED BY OTHERS.
 2. ALL DIMENSIONS ARE IN INCHES.
 3. FOR OUTLINE DETAILS REFER TO DRAWING 88-791640-04.


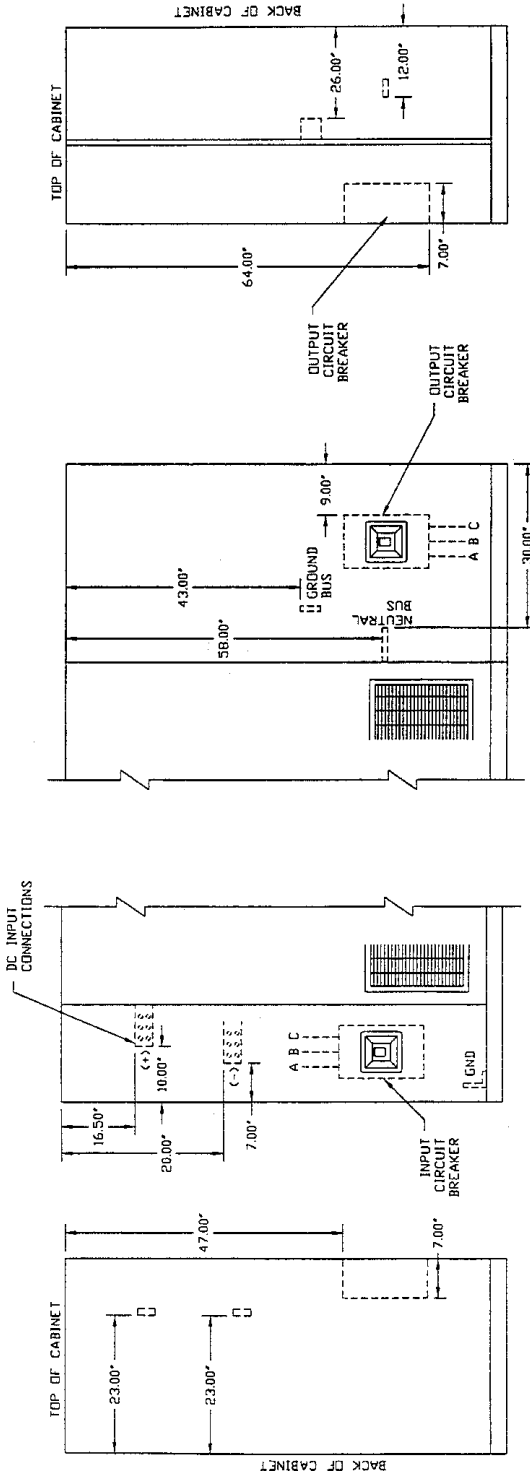
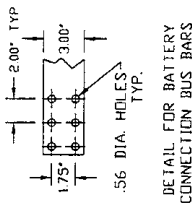
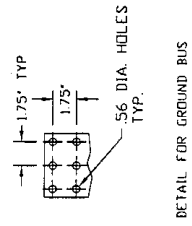
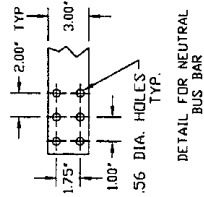
DRAWN BY D. MCKAY		SHEET NO 1 OF 1		TITLE BUSSING DETAILS 338 KVA MULTI-MODULE UPS 480 V AND 600 V SERIES 600	
CHK BY J. CAMPBELL		ECN NO		DWG. NO. 88-791640-94	
DES. APVL		REF. DWG. DB6-4094		DATE 02/07/95	
				ORDER NO.	
				REV. NO. 1	
				FILE NAME: DB64094.DWG	
				 9650 MERCED RD. IRVINE, CALIFORNIA 92718	

Figure 43 Bussing Details, 400 kVA

- NOTES:
1. FOR CONNECTION TO BUS BARS, LUGS TO BE PROVIDED BY OTHERS.
 2. ALL DIMENSIONS ARE IN INCHES.
 3. FOR OUTLINE DETAILS REFER TO DRAWING BB-791649-84.

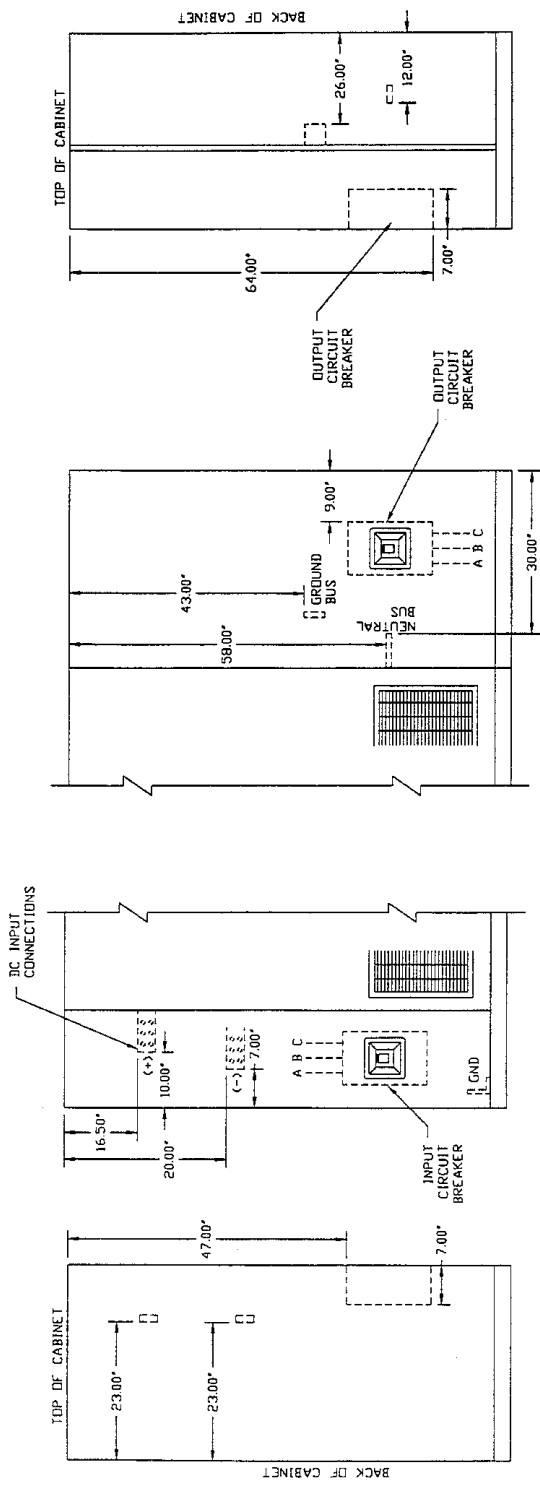
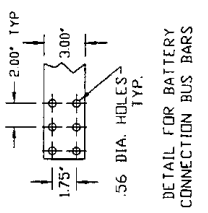
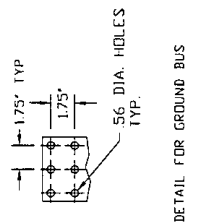
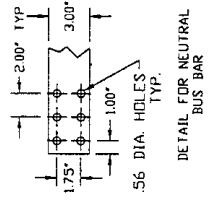


DRAWN BY B FISH		SHEET NO 1 OF 1		TITLE BUSSING DETAILS	
CHK BY J CAMPBELL		ECN NO		400 KVA MULTI-MODULE UPS 480 V AND 600 V SERIES 600	
DES APVL		REF. DWG. DB64994		DWG. NO. 88-791649-94	
		DATE 05/24/95		ORDER NO.	
		REV. NO. 1		FILE NAME: DB64994J.DWG	



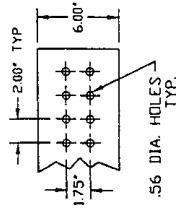
Figure 44 Bussing Details, 500 kVA

- NOTES:
1. FOR CONNECTION TO BUS BARS, LUGS TO BE PROVIDED BY OTHERS.
 2. ALL DIMENSIONS ARE IN INCHES.
 3. FOR OUTLINE DETAILS REFER TO DRAWING BB-791659-84.

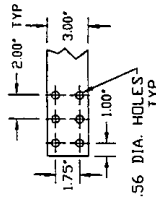


DRAWN BY B FISH		SHEET NO 1 OF 1		TITLE BUSSEING DETAILS	
CHK BY J CAMPBELL		ECN NO		500 KVA MULTI-MODULE UPS 480 V AND 600 V SERIES 600	
DES APVL		REF. DWG. DB65994		DWG. NO. 88-791659-94	
		DATE 05/30/95		REV. NO. 1	
		ORDER NO.		IRVINE, CALIFORNIA 92718	
		FILE NAME DB65994.DWG		Liebert 9650 JERONIMO RD. IRVINE, CALIFORNIA 92718	

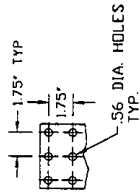
Figure 45 Bussing Details, 500 kVA, 208 VAC



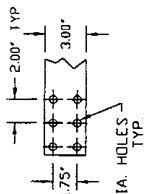
DETAIL FOR AC OUTPUT BUS BARS



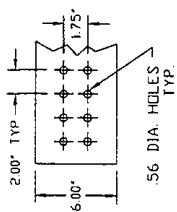
DETAIL FOR NEUTRAL BUS BAR



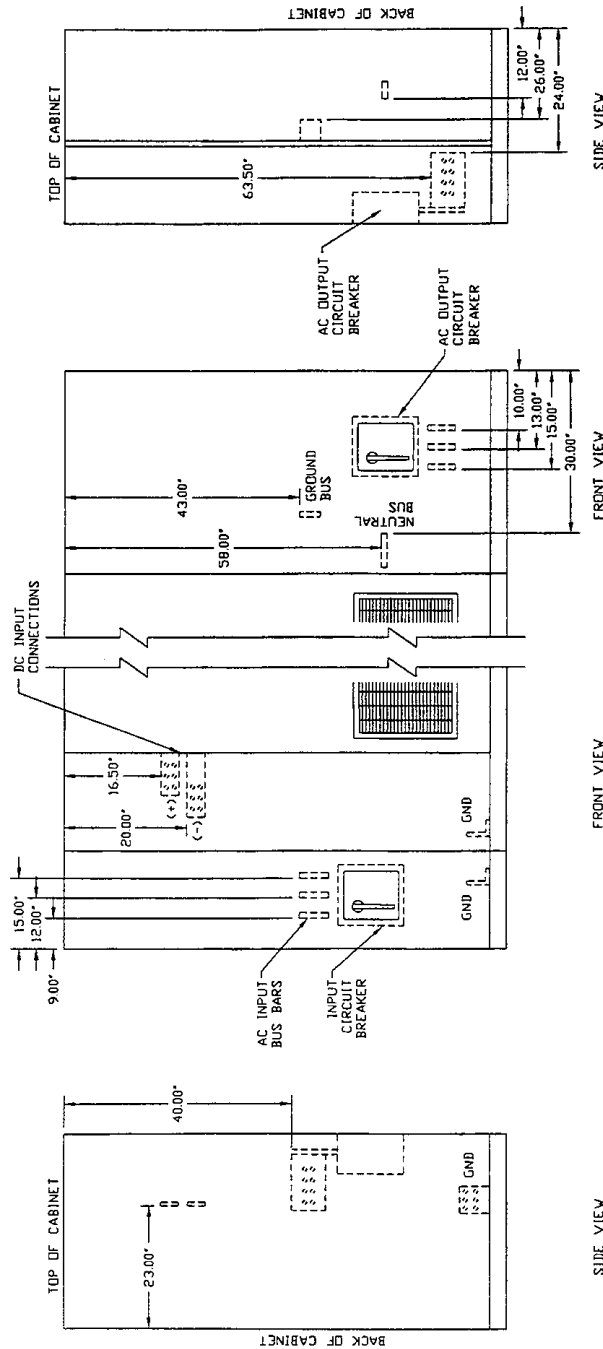
DETAIL FOR GROUND BUS



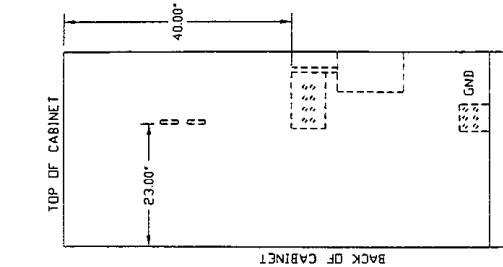
CONNECTION DETAILS DC INPUT BUS BARS



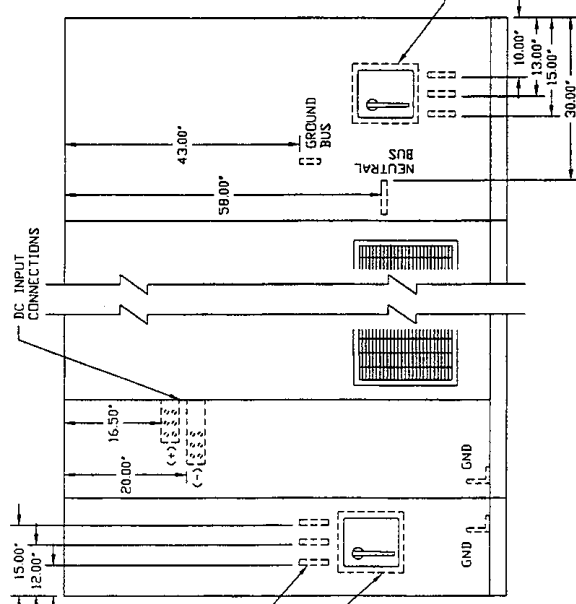
CONNECTION DETAILS AC INPUT BUS BARS



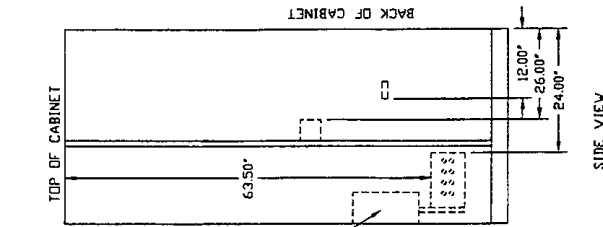
FRONT VIEW



SIDE VIEW



FRONT VIEW



SIDE VIEW

NOTES:

1. FOR CONNECTION TO BUS BARS, LUGS TO BE PROVIDED BY OTHERS.
2. ALL DIMENSIONS ARE IN INCHES.
3. FOR OUTLINE DETAILS REFER TO DRAWING 88-791659-81.


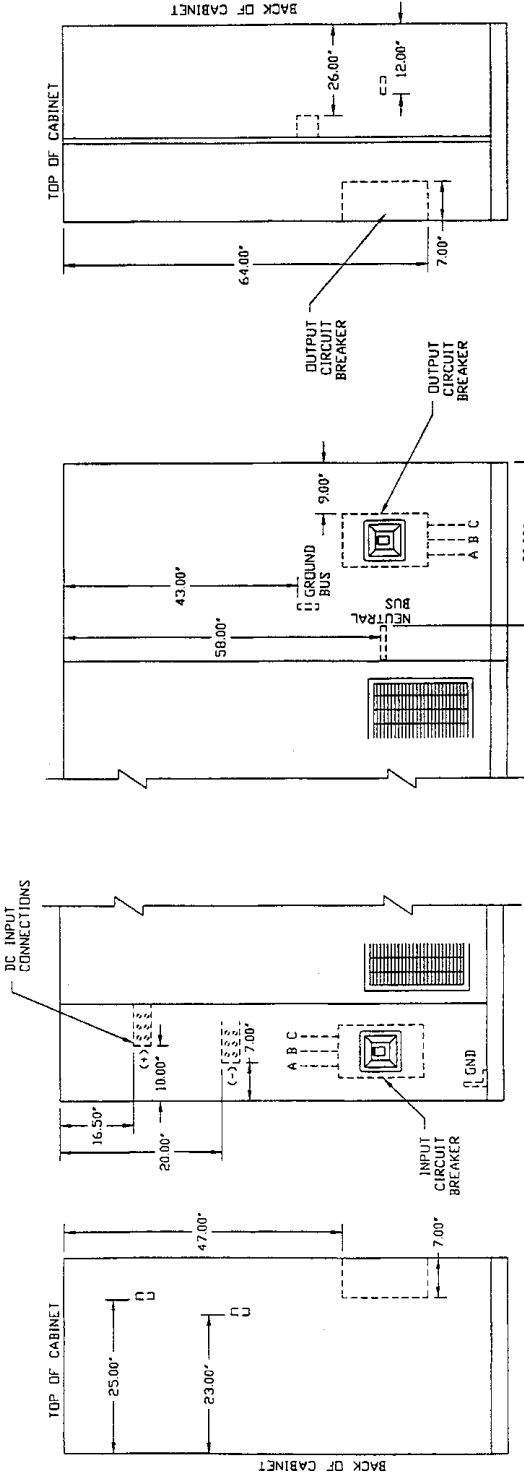
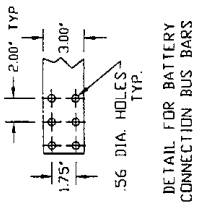
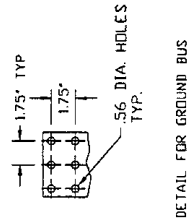
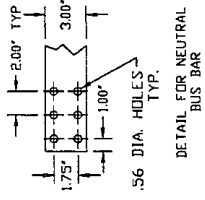
DRAWN BY B FISH		SHEET NO 1 OF 1		TITLE BUSsing DETAILS	
CHK BY J CAMPBELL		ECN NO		500 KVA MULTI-MODULE UPS	
DES APVL		REF. DWG. DB65991		208 V INPUT - 208 / 120 V OUTPUT SERIES 600	
DWG. NO. 88-791659-91		DATE 05/30/95		ORDER NO.	
REV. NO. 1		FILE NAME DB65991.DWG		 9650 JERONIMO RD. IRVINE, CALIFORNIA 92718	

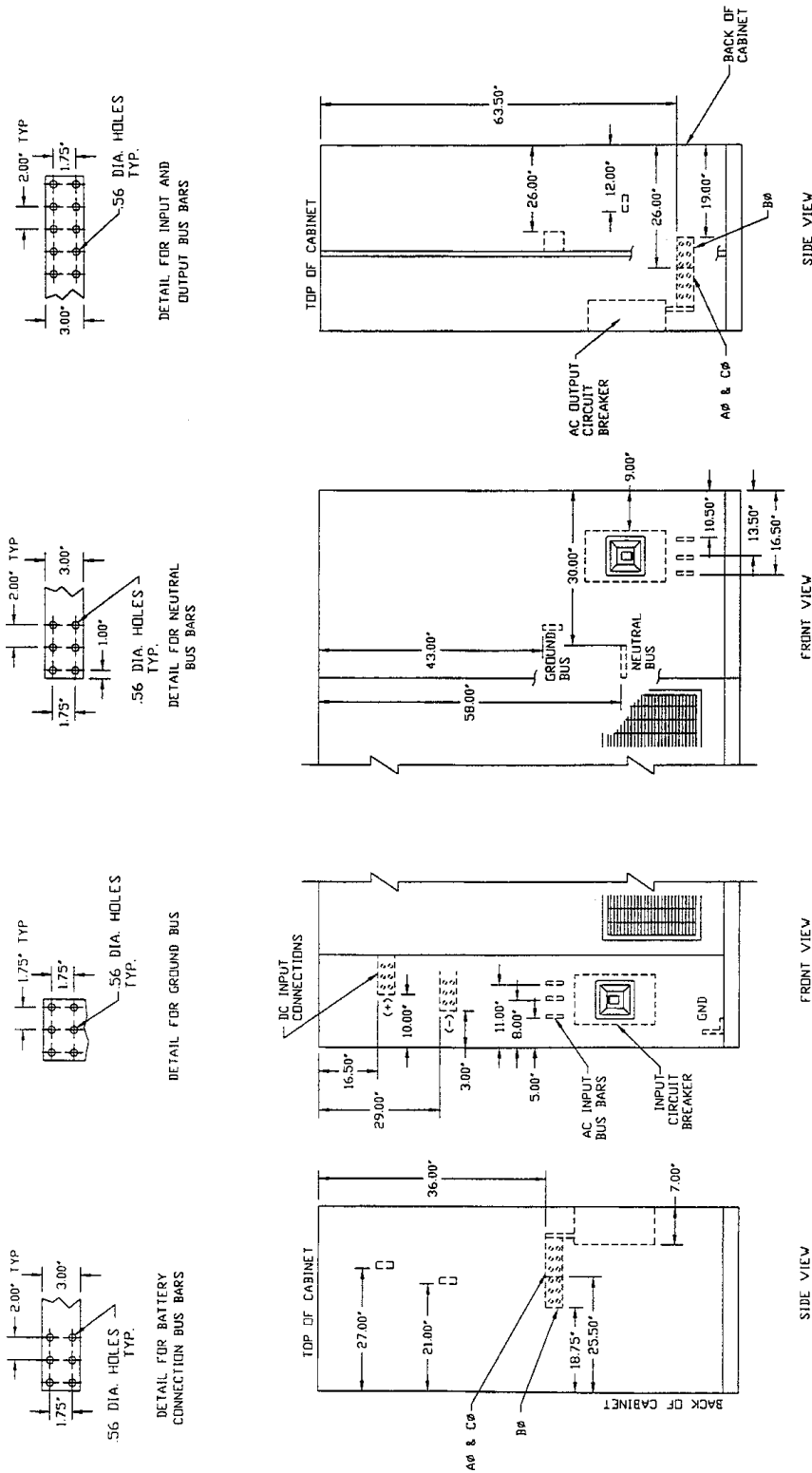
Figure 46 Bussing Details, 625 kVA



- NOTES:
1. FOR CONNECTION TO BUS BARS, LUGS TO BE PROVIDED BY OTHERS.
 2. ALL DIMENSIONS ARE IN INCHES.
 3. FOR OUTLINE DETAILS REFER TO DRAWING 88-791671-84.

DRAWN BY B FISH		SHEET NO 1 OF 1		TITLE BUSSING DETAILS	
CHK BY J CAMPBELL		ECN NO		625 KVA MULTI-MODULE UPS	
DES APVL		REF. DWG. DB67194		480 V AND 600 V SERIES 600	
DWG. NO. 88-791671-94		DATE 05/31/95		REV. NO. 1	
REV. NO. 1		ORDER NO.		 9650 JERONIMO RD. IRVINE, CALIFORNIA 92718	
FILE NAME: DB67194.DWG					

Figure 47 Bussing Details, 750 kVA (High Link - 240 Cells)

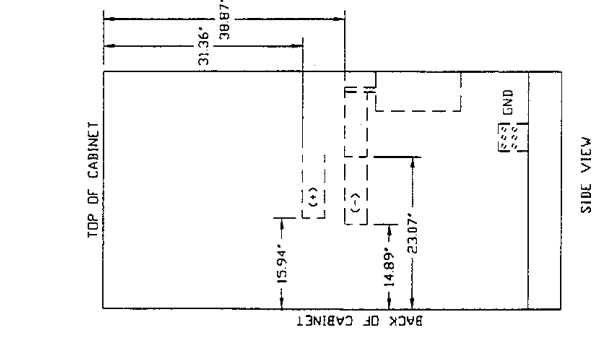
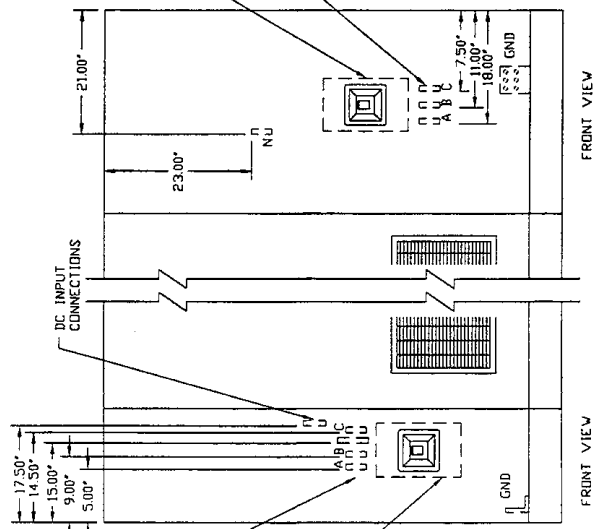
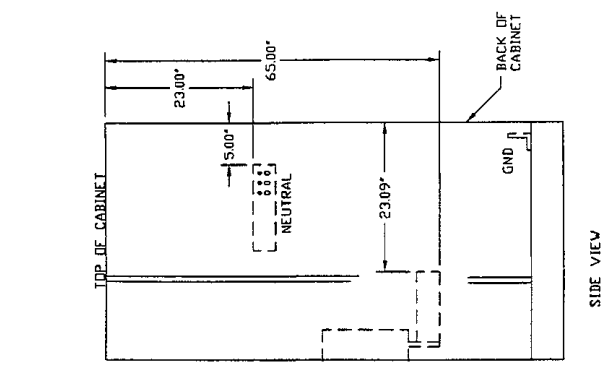
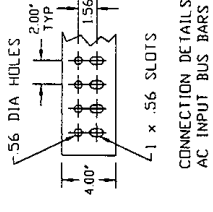
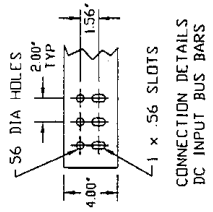
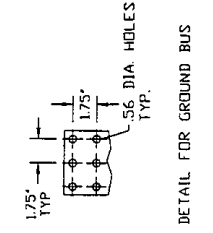
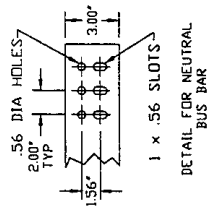
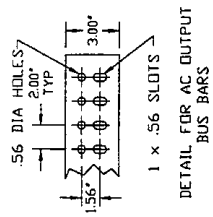


- NOTES:
1. FOR CONNECTION TO BUS BARS, LUGS TO BE PROVIDED BY OTHERS.
 2. ALL DIMENSIONS ARE IN INCHES.
 3. FOR OUTLINE DETAILS REFER TO DRAWING 88-791675-84.

DRAWN BY B FISH		SHEET NO 1 OF 1		TITLE BUSSING DETAILS 750 KVA - 240 CELL MULTI-MODULE UPS 480 V AND 600 V SERIES 600	
CHK BY J CAMPBELL		ECN NO		DWG. NO. 88-791675-94	
DES APVL		REF. DWG. DB67594		DATE 06/01/95	
				ORDER NO.	
				REV. NO. 1	
FILE NAME: DB67594.DWG					



Figure 48 Bussing Details, 750 kVA (Low Link - 180 Cells)



NOTES:
 1. FOR CONNECTION TO BUS BARS, LUGS TO BE PROVIDED BY OTHERS.
 2. ALL DIMENSIONS ARE IN INCHES.
 3. FOR OUTLINE DETAILS REFER TO DRAWING 88-791676-24.


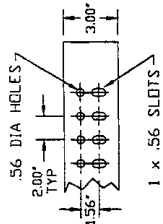
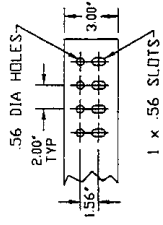
DRAWN BY B FISH		SHEET NO 1 OF 1	
CHK BY J CAMPBELL		ECN NO	
DES APVL		REF. DWG. DBG7644	
TITLE BUSSING DETAILS 750 KVA - 180 CELL FRONT ACCESS MULTI-MODULE UPS 480 V AND 600 V SERIES 600			
DWG. NO. 88-791676-44		DATE 06/05/95	
REV. NO. 1		ORDER NO.	
FILE NAME: DBG7644.DWG  9650 JERONIMO RD. IRVINE, CALIFORNIA 92718			

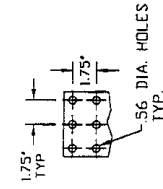
Figure 49 Bussing Details, 1000 kVA



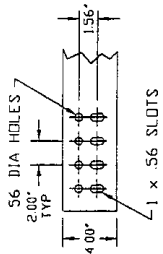
DETAIL FOR AC OUTPUT BUS BARS



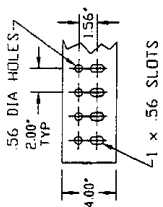
DETAIL FOR NEUTRAL BUS BAR



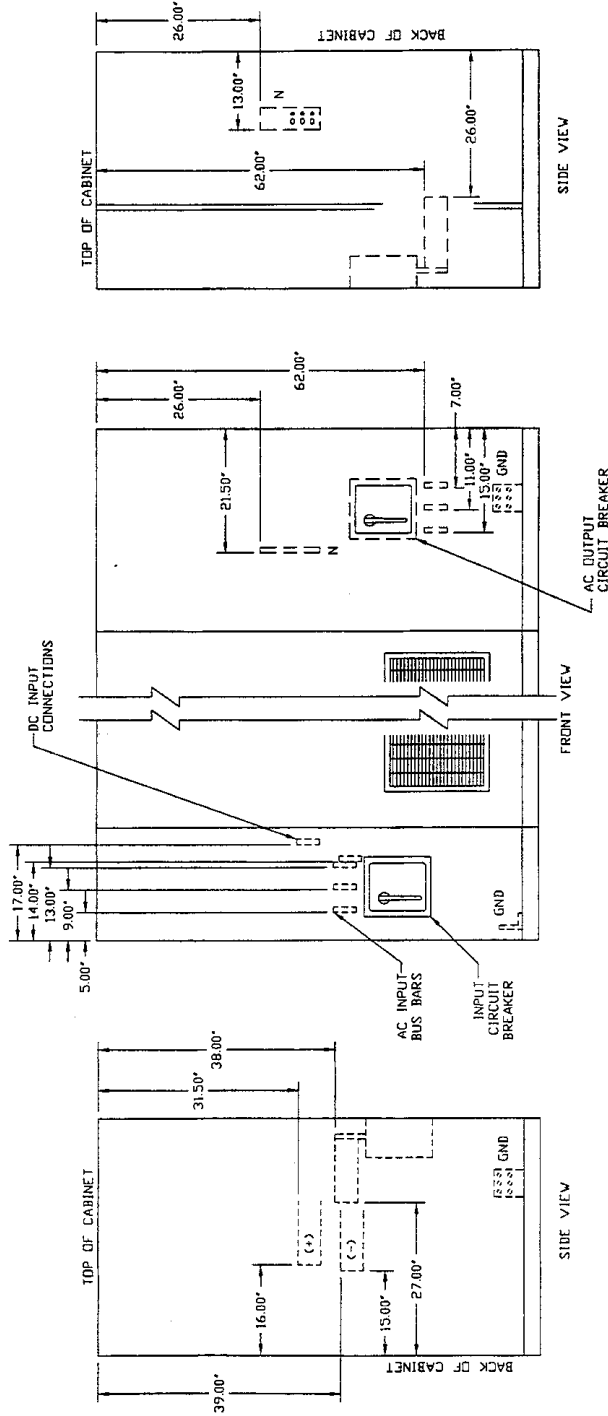
DETAIL FOR GROUND BUS



CONNECTION DETAILS DC INPUT BUS BARS



CONNECTION DETAILS AC INPUT BUS BARS

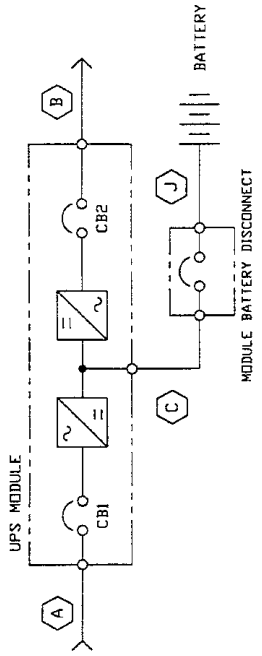


- NOTES:
1. FOR CONNECTION TO BUS BARS, LUGS TO BE PROVIDED BY OTHERS.
 2. ALL DIMENSIONS ARE IN INCHES.
 3. FOR OUTLINE DETAILS REFER TO DRAWING 88-791685-24.

DRAWN BY B FISH		SHEET NO 1 OF 1	
CHK BY J CAMPBELL		ECN NO	
DES APVL		REF. DWG. DB68544	
TITLE BUSSING DETAILS 1000 KVA FRONT ACCESS MULTI-MODULE UPS 480 V AND 600 V SERIES 600			
DWG. NO. 88-791685-44		DATE 06/07/95	
REV. NO. 1		ORDER NO.	
Liebert 9650 JERONIMO RD. IRVINE, CALIFORNIA 92718			

Figure 50 Module One-Line Diagram, 338 kVA

- NOTES:
1. NOMINAL CURRENT IS BASED ON FULL RATED OUTPUT LOAD.
 2. MAXIMUM CURRENT IS COMBINATION OF SHORT DURATION LOAD CURRENT (NONCONTINUOUS LOAD) FOR BATTERY RECHARGE PLUS NOMINAL FULL LOAD CURRENT (CONTINUOUS LOAD) PER NEC 100.
 3. MAXIMUM CURRENT IS COMBINATION OF SHORT DURATION LOAD CURRENT (NONCONTINUOUS LOAD) FOR 10 MINUTE OVERLOAD RATING PLUS NOMINAL FULL LOAD CURRENT (CONTINUOUS LOAD) PER NEC 100.
 4. UPS OUTPUT LOAD CABLES MUST BE RUN IN SEPARATE CONDUIT FROM INPUT CABLES.
 5. POWER CABLES FROM DC LINK TO BATTERIES SHOULD BE SIZED FOR TOTAL MAXIMUM 2.0 VOLT LINE DROP AT MAXIMUM DISCHARGE CURRENT. MAXIMUM CURRENT AT END OF BATTERY DISCHARGE (300 VDC) IS DEFINED AS NONCONTINUOUS PER NEC 100.
 6. GROUNDING CONDUCTORS TO BE SIZED PER NEC 250-95. NEUTRAL CONDUCTOR IF USED SHOULD BE IN ACCORDANCE WITH NATIONAL AND LOCAL ELECTRICAL CODES.
 7. ALL WIRING IS TO BE IN ACCORDANCE WITH NATIONAL AND LOCAL ELECTRICAL CODES.
 8. MODULE BATTERY DISCONNECT IS PROVIDED IN A SEPARATE ENCLOSURE.
 9. POWER AND CONTROL WIRING TO BE RUN IN SEPARATE CONDUITS.
 10. WHEN A THREE POLE MODULE BATTERY DISCONNECT IS USED, ONE POLE MAY BE USED TO CENTER TAP THE BATTERY STRING. THIS WILL REDUCE THE MAXIMUM VOLTAGE BETWEEN ANY TWO POINTS TO ONE HALF THE STRING VOLTAGE WHEN THE MODULE BATTERY DISCONNECT IS OPEN.
 11. BREAKER DESCRIPTIONS
 CB1 - SQUARE D TYPE MHL36600, 1000 AF, 600 AT, 65 KAIC.
 CB2 - SQUARE D TYPE MHL36600, 1000 AF, 600 AT, 65 KAIC.
 12. NOMINAL HEAT GENERATION - 80,131 BTU/HR.



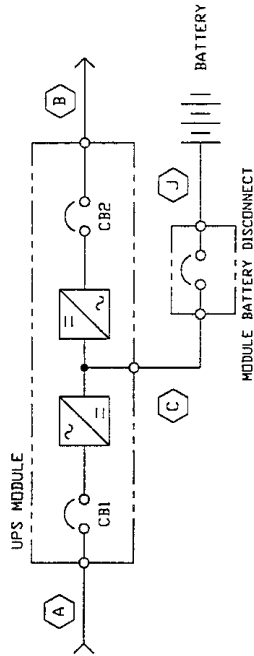
FEEDER	NOMINAL VOLTAGE	NOMINAL CURRENT	MAXIMUM CURRENT
(A) AC INPUT TO UPS 3 PHASE, 3 WIRE & GROUND. A-B-C ROTATION (SEE NOTES 1,2,4,6,7)	480 VAC	420 A	525 A (W/O FILTER) 474 A (WITH FILTER)
(B) AC OUTPUT TO LOAD, 3 PH, 4 WIRE & GROUND. A-B-C PHASE ROTATION (SEE NOTES 1,3,4,5,7) MAXIMUM 10 MIN. @ 125% OF NOMINAL CURRENT.	480Y/277 VAC	406 A	507 A
(C) UPS DC LINK TO MODULE BATTERY DISCONNECT. (1) POSITIVE, AND (2) NEGATIVE. (SEE NOTES 5,7,8)	360 VDC	800 A	993 A AT END OF DISCHARGE
(J) MODULE BATTERY DISCONNECT TO SYSTEM BATTERY. (1) POSITIVE, AND (2) NEGATIVE AND (3) POSITIVE, AND (4) NEGATIVE FOR CENTER TAP (SEE NOTES 5,7,8,10)	360 VDC	800 A	993 A AT END OF DISCHARGE

DRAWN BY D. MCKAY		SHEET NO 1 OF 1		ONE - LINE DIAGRAM 338 KVA / 270 KV PARALLEL MODULE UPS 480 V INPUT - 480 / 277 V OUTPUT SERIES 600	
CHK BY J. CAMPBELL		ECN NO			
DES. APVL		REF. DWG.			
		SL64084			
DWG. NO. 97-791640-84		DATE 02/08/95		9650 JERONIMO RD. IRVINE, CALIFORNIA 92718	
REV. NO. 1		ORDER NO.		FILE NAME: SL64084.DWG	

Figure 51 Module One-Line Diagram, 400 kVA

NOTES:

1. NOMINAL CURRENT IS BASED ON FULL RATED OUTPUT LOAD.
2. MAXIMUM CURRENT IS COMBINATION OF SHORT DURATION LOAD CURRENT (NONCONTINUOUS LOAD) FOR BATTERY RECHARGE PLUS NOMINAL FULL LOAD CURRENT (CONTINUOUS LOAD) PER NEC 100.
3. MAXIMUM CURRENT IS COMBINATION OF SHORT DURATION LOAD CURRENT (NONCONTINUOUS LOAD) FOR 10 MINUTE OVERLOAD RATING PLUS NOMINAL FULL LOAD CURRENT (CONTINUOUS LOAD) PER NEC 100.
4. UPS OUTPUT LOAD CABLES MUST BE RUN IN SEPARATE CONDUIT FROM INPUT CABLES.
5. POWER CABLES FROM DC LINK TO BATTERIES SHOULD BE SIZED FOR TOTAL MAXIMUM 20 VOLT LINE DROP AT MAXIMUM DISCHARGE CURRENT. MAXIMUM CURRENT AT END OF BATTERY DISCHARGE (300 VDC) IS DEFINED AS NONCONTINUOUS PER NEC 100.
6. GROUNDING CONDUCTORS TO BE SIZED PER NEC 250-95. NEUTRAL CONDUCTOR (IF USED) SHOULD BE SIZED FOR FULL CAPACITY.
7. ALL WIRING IS TO BE IN ACCORDANCE WITH NATIONAL AND LOCAL ELECTRICAL CODES.
8. MODULE BATTERY DISCONNECT IS PROVIDED IN A SEPARATE ENCLOSURE.
9. POWER AND CONTROL WIRING TO BE RUN IN SEPARATE CONDUITS.
10. WHEN A THREE POLE MODULE BATTERY DISCONNECT IS USED, ONE POLE MAY BE USED TO CENTER TAP THE BATTERY STRING. THIS WILL REDUCE THE MAXIMUM VOLTAGE BETWEEN ANY TWO POINTS TO ONE HALF THE STRING VOLTAGE WHEN THE MODULE BATTERY DISCONNECT IS OPEN.
11. BREAKER DESCRIPTIONS
 CBI - SQUARE D TYPE MHL36700, 1000 AF, 700 AT, 65 KAIC.
 CB2 - SQUARE D TYPE MHL36600, 1000 AF, 600 AT, 65 KAIC.
12. NOMINAL HEAT GENERATION - 94,970 BTU/HR.



FEEDEE	NOMINAL VOLTAGE	NOMINAL CURRENT	MAXIMUM CURRENT
(A) AC INPUT TO UPS 3 PHASE, 3 WIRE & GROUND. A-B-C ROTATION (SEE NOTES 1,2,4,6,7)	480 VAC	504 A 455 A	530 A (W/O FILTER) 568 A (WITH FILTER)
(B) AC OUTPUT TO LOAD, 3 PH, 4 WIRE & GROUND. A-B-C PHASE ROTATION (SEE NOTES 1,3,4,6,7) MAXIMUM 10 MIN. @ 125% OF NOMINAL CURRENT.	480Y/277 VAC	481 A	601 A
(C) UPS DC LINK TO MODULE BATTERY DISCONNECT. (1) POSITIVE, AND (2) NEGATIVE. (SEE NOTES 5,7,8)	360 VDC	943 A	1170 A AT END OF DISCHARGE
(J) MODULE BATTERY DISCONNECT TO SYSTEM BATTERY. (1) POSITIVE, AND (2) NEGATIVE AND (3) POSITIVE, AND (4) NEGATIVE FOR CENTER TAP (SEE NOTES 5,7,8,10)	360 VDC	943 A	1170 A AT END OF DISCHARGE

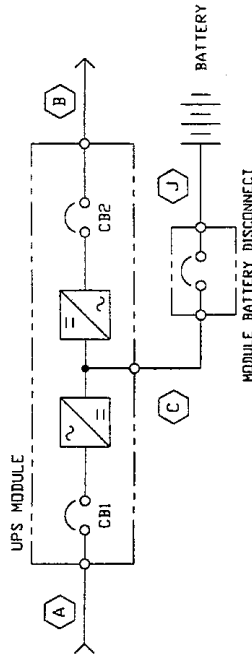
DRAWN BY D MCKAY	SHEET NO 1 OF 1	TITLE ONE - LINE DIAGRAM 400 KVA / 320 KW PARALLEL MODULE UPS	 IRVINE, CALIFORNIA 92718
CHK BY J CAMPBELL	ECN NO	480 V INPUT - 480 / 277 V OUTPUT SERIES 600	DWG. NO. 97-791648-84
DES APVL	REF. DWG. SL64884		DATE 02/17/95
			ORDER NO.
			REV. NO. 1

FILE NAME: SL64884.DWG

Figure 52 Module One-Line Diagram, 500 kVA

NOTES:

1. NOMINAL CURRENT IS BASED ON FULL RATED OUTPUT LOAD.
2. MAXIMUM CURRENT IS COMBINATION OF SHORT DURATION LOAD CURRENT (NONCONTINUOUS LOAD) FOR BATTERY RECHARGE PLUS NOMINAL FULL LOAD CURRENT (CONTINUOUS LOAD) PER NEC 100.
3. MAXIMUM CURRENT IS COMBINATION OF SHORT DURATION LOAD CURRENT (NONCONTINUOUS LOAD) FOR 10 MINUTE OVERLOAD RATING PLUS NOMINAL FULL LOAD CURRENT (CONTINUOUS LOAD) PER NEC 100.
4. UPS OUTPUT LOAD CABLES MUST BE RUN IN SEPARATE CONDUIT FROM INPUT CABLES.
5. POWER CABLES FROM DC LINK TO BATTERIES SHOULD BE SIZED FOR TOTAL MAXIMUM 2.0 VOLT LINE DROP AT MAXIMUM DISCHARGE CURRENT. MAXIMUM CURRENT AT END OF BATTERY DISCHARGE (300 VDC) IS DEFINED AS NONCONTINUOUS PER NEC 100.
6. GROUNDING CONDUCTORS TO BE SIZED PER NEC 250-95. NEUTRAL CONDUCTOR (IF USED) SHOULD BE SIZED FOR FULL CAPACITY.
7. ALL WIRING IS TO BE IN ACCORDANCE WITH NATIONAL AND LOCAL ELECTRICAL CODES.
8. MODULE BATTERY DISCONNECT IS PROVIDED IN A SEPARATE ENCLOSURE.
9. POWER AND CONTROL WIRING TO BE RUN IN SEPARATE CONDUITS.
10. WHEN A THREE POLE MODULE BATTERY DISCONNECT IS USED, ONE POLE MAY BE USED TO CENTER TAP THE BATTERY STRING. THIS WILL REDUCE THE MAXIMUM VOLTAGE BETWEEN ANY TWO POINTS TO ONE HALF THE STRING VOLTAGE WHEN THE MODULE BATTERY DISCONNECT IS OPEN.
11. BREAKER DESCRIPTIONS
 CBI - SQUARE D TYPE MHL36900, 1000 AF, 900 AT, 65 KAIC.
 CB2 - SQUARE D TYPE MHL36800, 1000 AF, 800 AT, 65 KAIC.
12. NOMINAL HEAT GENERATION - 118,713 BTU/HR.



FEEDER	NOMINAL VOLTAGE	NOMINAL CURRENT	MAXIMUM CURRENT
A	480 VAC	530 A 562 A	788 A (W/O FILTER) 703 A (WITH FILTER)
B	480Y/277 VAC	601 A	752 A
C	360 VDC	1178 A	1463 A AT END OF DISCHARGE
J	360 VDC	1178 A	1463 A AT END OF DISCHARGE

DRAWN BY D MCKAY		SHEET NO 1 OF 1		TITLE ONE - LINE DIAGRAM 500 KVA / 400 KW PARALLEL MODULE UPS 480 V INPUT - 480 / 277 V OUTPUT SERIES 600	
CHK BY J CAMPBELL		ECN NO		DWG. NO. 97-791658-84	
DES APVL		REF. DWG. SL65884		DATE 02/21/95	
				ORDER NO.	

FILE NAME: SL65884.DWG

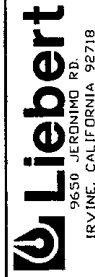
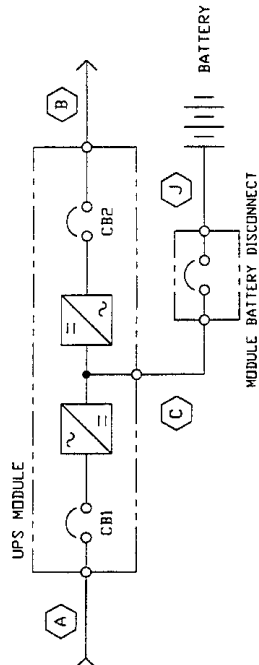


Figure 53 Module One-Line Diagram, 500 kVA, 208 VAC

NOTES:

1. NOMINAL CURRENT IS BASED ON FULL RATED OUTPUT LOAD.
2. MAXIMUM CURRENT IS COMBINATION OF SHORT DURATION LOAD CURRENT (NONCONTINUOUS LOAD) FOR BATTERY RECHARGE, PLUS NOMINAL FULL LOAD CURRENT (CONTINUOUS LOAD) PER NEC 100.
3. MAXIMUM CURRENT IS COMBINATION OF SHORT DURATION LOAD CURRENT (NONCONTINUOUS LOAD) FOR 10 MINUTE OVERLOAD RATING PLUS NOMINAL FULL LOAD CURRENT (CONTINUOUS LOAD) PER NEC 100.
4. UPS OUTPUT LOAD CABLES MUST BE RUN IN SEPARATE CONDUIT FROM INPUT CABLES.
5. POWER CABLES FROM DC LINK TO BATTERIES SHOULD BE SIZED FOR TOTAL MAXIMUM 2.0 VOLT LINE DROP AT MAXIMUM DISCHARGE CURRENT. MAXIMUM CURRENT AT END OF BATTERY DISCHARGE (300 VDC) IS DEFINED AS NONCONTINUOUS PER NEC 100.
6. GROUNDING CONDUCTORS TO BE SIZED PER NEC 250-95. NEUTRAL CONDUCTOR (IF USED) SHOULD BE SIZED FOR FULL CAPACITY.
7. ALL WIRING IS TO BE IN ACCORDANCE WITH NATIONAL AND LOCAL ELECTRICAL CODES.
8. MODULE BATTERY DISCONNECT IS PROVIDED IN A SEPARATE ENCLOSURE.
9. POWER AND CONTROL WIRING TO BE RUN IN SEPARATE CONDUITS.
10. WHEN A THREE-POLE MODULE BATTERY DISCONNECT IS USED, ONE POLE MAY BE USED TO CENTER TAP THE BATTERY STRING. THIS WILL REDUCE THE MAXIMUM VOLTAGE BETWEEN ANY TWO POINTS TO ONE HALF THE STRING VOLTAGE WHEN THE MODULE BATTERY DISCONNECT IS OPEN.
11. BREAKER DESCRIPTIONS:
 CB1 - SQUARE D TYPE PHF2036, 2000 AF, 2000 AT, 125 KAIC.
 CB2 - SQUARE D TYPE PHF2036, 2000 AF, 1800 AT, 125 KAIC.
12. NOMINAL HEAT GENERATION - 126.822 BTU/HR.



FEEIDER	NOMINAL VOLTAGE	NOMINAL CURRENT	MAXIMUM CURRENT
(A) AC INPUT TO UPS, 3 PHASE, 3 WIRE & GROUND. A-B-C ROTATION (SEE NOTES 1,2,4,6,7)	208 VAC	1462 A 1333 A	1827 A (W/O FILTER) 1667 A (WITH FILTER)
(B) AC OUTPUT TO LOAD, 3 PH, 4 WIRE & GROUND. A-B-C PHASE ROTATION (SEE NOTES 1,3,4,6,7). MAXIMUM 10 MIN. @ 125% OF NOMINAL CURRENT.	208Y/120 VAC	1388 A	1735 A
(C) UPS DC LINK TO MODULE BATTERY DISCONNECT. (D) POSITIVE, AND (E) NEGATIVE. (SEE NOTES 5,7,8)	360 VDC	1185 A	1470 A AT END OF DISCHARGE
(J) MODULE BATTERY DISCONNECT TO SYSTEM BATTERY. (D) POSITIVE, AND (E) NEGATIVE AND (F) POSITIVE, AND (G) NEGATIVE FOR CENTER TAP (SEE NOTES 5,7,8)	360 VDC	1185 A	1470 A AT END OF DISCHARGE

DRAWN BY D MCKAY	SHEET NO 1 OF 1	TITLE ONE - LINE DIAGRAM 500 KVA / 400 KW PARALLEL MODULE UPS 208 V INPUT - 208 / 120 V OUTPUT SERIES 600	
CHK BY J CAMPBELL	ECN NO	DWG. NO. 97-791658-81	DATE 02/21/95
DES APVL SL65881	REF. DWG.	REV. NO. 1	ORDER NO.

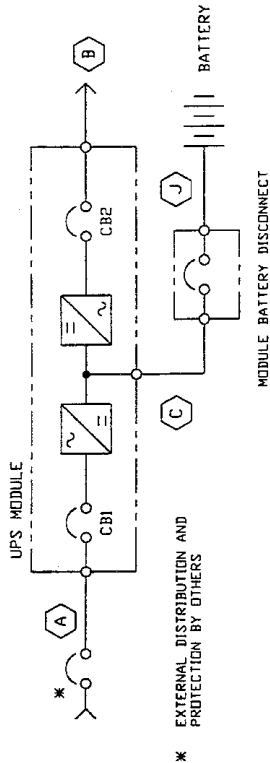
Liebert
9650 FERDINAND RD.
IRVINE, CALIFORNIA 92718

FILE NAME: SL65881.DWG

Figure 54 Module One-Line Diagram, 625 kVA

NOTES:

1. NOMINAL CURRENT IS BASED ON FULL RATED OUTPUT LOAD.
2. MAXIMUM CURRENT IS COMBINATION OF SHORT DURATION LOAD CURRENT (NONCONTINUOUS LOAD) FOR BATTERY RECHARGE PLUS NOMINAL FULL LOAD CURRENT (CONTINUOUS LOAD) PER NEC 100.
3. MAXIMUM CURRENT IS COMBINATION OF SHORT DURATION LOAD CURRENT (NONCONTINUOUS LOAD) FOR 10 MINUTE OVERLOAD RATING PLUS NOMINAL FULL LOAD CURRENT (CONTINUOUS LOAD) PER NEC 100.
4. UPS OUTPUT CABLES MUST BE RUN IN SEPARATE CONDUIT FROM INPUT CABLES.
5. POWER CABLES FROM DC LINK TO BATTERIES SHOULD BE SIZED FOR TOTAL MAXIMUM 2.0 VOLT LINE DROP AT MAXIMUM DISCHARGE CURRENT. MAXIMUM CURRENT AT END OF BATTERY DISCHARGE (300 VDC) IS DEFINED AS NONCONTINUOUS PER NEC 100.
6. GROUNDING CONDUCTORS TO BE SIZED PER NEC 250-95 NEUTRAL CONDUCTOR (IF USED) SHOULD BE SIZED FOR FULL CAPACITY.
7. ALL WIRING IS TO BE IN ACCORDANCE WITH NATIONAL AND LOCAL ELECTRICAL CODES.
8. MODULE BATTERY DISCONNECT IS PROVIDED IN A SEPARATE ENCLOSURE.
9. POWER AND CONTROL WIRING TO BE RUN IN SEPARATE CONDUITS.
10. WHEN A THREE POLE MODULE BATTERY DISCONNECT IS USED, ONE POLE MAY BE USED TO CENTER TAP THE BATTERY STRING. THIS WILL REDUCE THE MAXIMUM VOLTAGE BETWEEN ANY TWO POINTS TO ONE HALF THE STRING VOLTAGE WHEN THE MODULE BATTERY DISCONNECT IS OPEN.
11. BREAKER DESCRIPTIONS
 CBI -- SQUARE D TYPE MHL361000, 1000 AF, 1000 AT, 65 KAIC.
 CB2 -- SQUARE D TYPE MHL361000, 1000 AF, 1000 AT, 65 KAIC.
12. NOMINAL HEAT GENERATION - 148,391 BTU/HR.



FEEDER	NOMINAL VOLTAGE	NOMINAL CURRENT	MAXIMUM CURRENT
A	480 VAC	778 A 711 A	973 A (W/O FILTER) 888 A (WITH FILTER)
B	480Y/277 VAC	752 A	940 A
C	360 VDC	1473 A	1828 A AT END OF DISCHARGE
J	360 VDC	1473 A	1828 A AT END OF DISCHARGE

DRAWN BY D MCKAY		SHEET NO 1 OF 1		TITLE ONE - LINE DIAGRAM 625 KVA / 500 KW PARALLEL MODULE UPS	
CHK BY J CAMPBELL		ECN NO		480 V INPUT - 480 / 277 V OUTPUT SERIES 600	
DES APVL		REF. DWG. SL67084		DWG. NO. 97-791670-84	
				DATE 02/21/95	
				ORDER NO.	

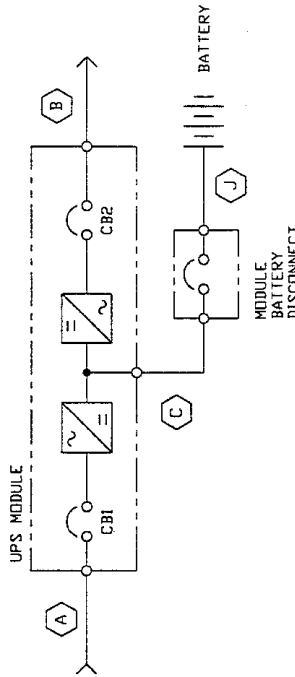


FILE NAME: SL67084.DWG

Figure 55 Module One-Line Diagram, 750 kVA (High Link - 240 Cells)

NOTES:

1. NOMINAL CURRENT IS BASED ON FULL RATED OUTPUT LOAD.
2. MAXIMUM CURRENT IS COMBINATION OF SHORT DURATION LOAD CURRENT (NONCONTINUOUS LOAD) FOR BATTERY RECHARGE PLUS NOMINAL FULL LOAD CURRENT (CONTINUOUS LOAD) PER NEC 100.
3. MAXIMUM CURRENT IS COMBINATION OF SHORT DURATION LOAD CURRENT (NONCONTINUOUS LOAD) FOR 10 MINUTE OVERLOAD RATING PLUS NOMINAL FULL LOAD CURRENT (CONTINUOUS LOAD) PER NEC 100.
4. UPS OUTPUT LEAD CABLES MUST BE RUN IN SEPARATE CONDUIT FROM INPUT CABLES.
5. POWER CABLES FROM DC LINK TO BATTERIES SHOULD BE SIZED FOR TOTAL MAXIMUM 20 VOLT LINE DROP AT MAXIMUM DISCHARGE CURRENT. MAXIMUM CURRENT AT END OF BATTERY DISCHARGE (400 VDC) IS DEFINED AS NONCONTINUOUS PER NEC 100.
6. GROUNDING CONDUCTORS TO BE SIZED PER NEC 250-95. NEUTRAL CONDUCTOR MUST BE SIZED FOR FULL CAPACITY OR PER NEC 220-22.
7. ALL WIRING IS TO BE IN ACCORDANCE WITH NATIONAL AND LOCAL ELECTRICAL CODES.
8. MODULE BATTERY DISCONNECT IS PROVIDED IN A SEPARATE ENCLOSURE.
9. POWER AND CONTROL WIRING TO BE RUN IN SEPARATE CONDUITS.
10. WHEN A THREE POLE MODULE BATTERY DISCONNECT IS USED, ONE POLE MAY BE USED TO CENTER TAP THE BATTERY STRING. THIS WILL REDUCE THE MAXIMUM VOLTAGE BETWEEN ANY TWO POINTS TO ONE HALF THE STRING VOLTAGE WHEN THE MODULE BATTERY DISCONNECT IS OPEN.
11. BREAKER DESCRIPTIONS
 CBI - SQUARE D TYPE MHL361200, 1200 AF, 1200 AT, 65 KAIC.
 CB2 - SQUARE D TYPE MHL361200, 1200 AF, 1200 AT, 65 KAIC.
12. NOMINAL HEAT GENERATION - 178,070 BTU/HR.



FEEDER	NOMINAL VOLTAGE	NOMINAL CURRENT	MAXIMUM CURRENT
(A) AC INPUT TO UPS 3 PHASE, 3 WIRE & GROUND. A-B-C ROTATION (SEE NOTES 1,2,4,6,7)	480 VAC	934 A 853 A	1167 A (W/O FILTER) 1066 A (WITH FILTER)
(B) AC OUTPUT TO SYSTEM CONTROL CABINET, 3 PH. 4 WIRE & GROUND. A-B-C PHASE ROTATION (SEE NOTES 1,3,4,6,7). MAXIMUM 10 MIN. @ 125% OF NOMINAL CURRENT.	480Y/277 VAC	902 A	1128 A
(C) UPS DC LINK TO MODULE BATTERY DISCONNECT. (1) POSITIVE, AND (1) NEGATIVE. (SEE NOTES 5,7,8)	480 VDC	1326 A	1644 A AT END OF DISCHARGE
(J) MODULE BATTERY DISCONNECT TO SYSTEM BATTERY. (1) POSITIVE, AND (1) NEGATIVE AND (1) POSITIVE, AND (1) NEGATIVE FOR CENTER TAP (SEE NOTES 5,7,8,10)	480 VDC	1326 A	1644 A AT END OF DISCHARGE

DRAWN BY D MCKAY	SHEET NO 1 OF 1	TITLE ONE - LINE DIAGRAM 750 KVA / 600 KW 240 CELLS PARALLEL MODULE UPS	
CHK BY J CAMPBELL	ECN NO	DWG. NO. 97-791675-84	DATE 03/01/95
DES APVL	REF. DWG. SL67584	REV. NO. 1	ORDER NO.

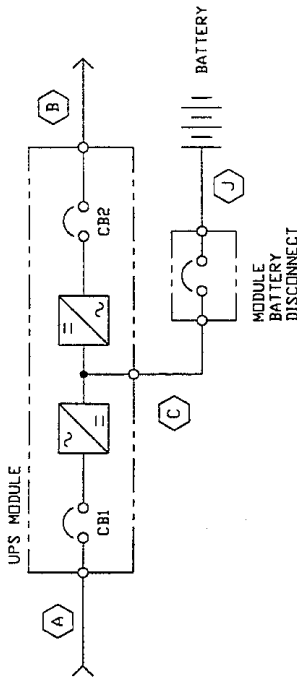


FILE NAME: SL67584.DWG

Figure 56 Module One-Line Diagram, 750 kVA (Low Link - 180 Cells)

NOTES:

1. NOMINAL CURRENT IS BASED ON FULL RATED OUTPUT LOAD.
2. MAXIMUM CURRENT IS COMBINATION OF SHORT DURATION LOAD CURRENT (NONCONTINUOUS LOAD) FOR BATTERY RECHARGE PLUS NOMINAL FULL LOAD CURRENT (CONTINUOUS LOAD) PER NEC 100.
3. MAXIMUM CURRENT IS COMBINATION OF SHORT DURATION LOAD CURRENT (NONCONTINUOUS LOAD) FOR 10 MINUTE OVERLOAD RATING PLUS NOMINAL FULL LOAD CURRENT (CONTINUOUS LOAD) PER NEC 100.
4. UPS OUTPUT LOAD CABLES MUST BE RUN IN SEPARATE CONDUIT FROM INPUT CABLES.
5. POWER CABLES FROM DC LINK TO BATTERIES SHOULD BE SIZED FOR TOTAL MAXIMUM 20 VOLT LINE DROP AT MAXIMUM DISCHARGE CURRENT. MAXIMUM CURRENT AT END OF BATTERY DISCHARGE (300 VDC) IS DEFINED AS NONCONTINUOUS PER NEC 100.
6. GROUNDING CONDUCTORS TO BE SIZED PER NEC 250-95. NEUTRAL CONDUCTOR MUST BE SIZED FOR FULL CAPACITY OR PER NEC 250-22.
7. ALL WIRING IS TO BE IN ACCORDANCE WITH NATIONAL AND LOCAL ELECTRICAL CODES.
8. MODULE BATTERY DISCONNECT IS PROVIDED IN A SEPARATE ENCLOSURE.
9. POWER AND CONTROL WIRING TO BE RUN IN SEPARATE CONDUITS.
10. WHEN A THREE POLE BATTERY DISCONNECT IS USED, ONE POLE MAY BE USED TO CENTER TAP THE BATTERY STRING. THIS WILL REDUCE THE MAXIMUM VOLTAGE BETWEEN ANY TWO POINTS TO ONE HALF THE STRING VOLTAGE WHEN THE MODULE BATTERY DISCONNECT IS OPEN.
11. BREAKER DESCRIPTIONS
 CBI - SQUARE D TYPE MHL361200, 1200 AF, 1200 AT, 65 KAIC.
 CB2 - SQUARE D TYPE MHL361200, 1200 AF, 1200 AT, 65 KAIC.
12. NOMINAL HEAT GENERATION - 178,070 BTU/HR



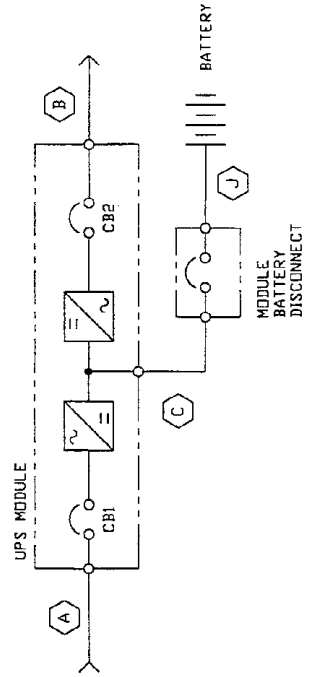
FEEDER	NOMINAL VOLTAGE	NOMINAL CURRENT	MAXIMUM CURRENT
A	480 VAC	934 A 853 A	1167 A (w/o FILTER) 1066 A (with FILTER)
B	480Y/277 VAC	902 A	1128 A
C	360 VDC	1767 A	2194 A AT END OF DISCHARGE
J	360 VDC	1767 A	2194 A AT END OF DISCHARGE

- A AC INPUT TO UPS 3 PHASE, 3 WIRE & GROUND. A-B-C ROTATION (SEE NOTES 1,2,4,6,7)
- B AC OUTPUT TO SYSTEM CONTROL CABINET, 3 PH. 4 WIRE & GROUND. A-B-C PHASE ROTATION (SEE NOTES 1,3,4,6,7) MAXIMUM TO MIN. @ 125% OF NOMINAL CURRENT.
- C UPS DC LINK TO MODULE BATTERY DISCONNECT. (1) POSITIVE, AND (2) NEGATIVE. (SEE NOTES 5,7,8)
- J MODULE BATTERY DISCONNECT TO SYSTEM BATTERY. (1) POSITIVE, AND (2) NEGATIVE AND (3) POSITIVE, AND (4) NEGATIVE FOR CENTER TAP (SEE NOTES 5,7,8,10)

DRAWN BY B FISH CHK BY J CAMPBELL DES APVL SL67624	SHEET NO 1 OF 1 ECN NO REF. DWG. SL67624	ONE - LINE DIAGRAM 750 KVA / 600 KW 180 CELLS PARALLEL MODULE UPS 480 V INPUT - 480 / 277 V OUTPUT SERIES 600	DWG. NO. 97-791676-24 REV. NO. 1 DATE 06/06/95 ORDER NO.
			IRVINE, CALIFORNIA 92718

Figure 57 Module One-Line Diagram, 1000 kVA

- NOTES:
1. NOMINAL CURRENT IS BASED ON FULL RATED OUTPUT LOAD.
 2. MAXIMUM CURRENT IS COMBINATION OF SHORT DURATION LOAD CURRENT (NONCONTINUOUS LOAD) FOR BATTERY RECHARGE PLUS NOMINAL FULL LOAD CURRENT (CONTINUOUS LOAD) PER NEC 100
 3. MAXIMUM CURRENT IS COMBINATION OF SHORT DURATION LOAD CURRENT (NONCONTINUOUS LOAD) FOR 10 MINUTE OVERLOAD RATING PLUS NOMINAL FULL LOAD CURRENT (CONTINUOUS LOAD) PER NEC 100.
 4. UPS OUTPUT LOAD CABLES MUST BE RUN IN SEPARATE CONDUIT FROM INPUT CABLES.
 5. POWER CABLES FROM DC LINK TO BATTERIES SHOULD BE SIZED FOR TOTAL MAXIMUM 20 VOLT LINE DROP AT MAXIMUM DISCHARGE CURRENT. MAXIMUM CURRENT AT END OF BATTERY DISCHARGE (400 VDC) IS DEFINED AS NONCONTINUOUS PER NEC 100.
 6. GROUNDING CONDUCTORS TO BE SIZED PER NEC 250-95. NEUTRAL CONDUCTOR MUST BE SIZED FOR FULL CAPACITY OR PER NEC 250-22.
 7. ALL WIRING IS TO BE IN ACCORDANCE WITH NATIONAL AND LOCAL ELECTRICAL CODES.
 8. MODULE BATTERY DISCONNECT IS PROVIDED IN A SEPARATE ENCLOSURE.
 9. POWER AND CONTROL WIRING TO BE RUN IN SEPARATE CONDUITS.
 10. WHEN A THREE POLE MODULE BATTERY DISCONNECT IS USED, ONE POLE MAY BE USED TO CENTER TAP THE BATTERY STRING. THIS WILL REDUCE THE MAXIMUM VOLTAGE BETWEEN ANY TWO POINTS TO ONE HALF THE STRING VOLTAGE WHEN THE MODULE BATTERY DISCONNECT IS OPEN.
 11. BREAKER DESCRIPTIONS
 CB1 - SQUARE D TYPE PHF2036, 2000 AF, 1600 AT, 100 KAIC.
 CB2 - SQUARE D TYPE PHF2036, 2000 AF, 1600 AT, 100 KAIC.
 12. NOMINAL HEAT GENERATION - 205.5/4 BTU/HR



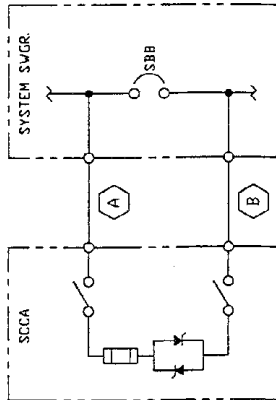
FEEDER	NOMINAL VOLTAGE	NOMINAL CURRENT	MAXIMUM CURRENT
(A) AC INPUT TO UPS 3 PHASE, 3 WIRE & GROUND. A-B-C ROTATION (SEE NOTES 1,2,4,6,7)	480 VAC	1217 A 1113 A	1522 A (w/o FILTER) 1351 A (WITH FILTER)
(B) AC OUTPUT TO SYSTEM CONTROL CABINET, 3 PH. 4 WIRE & GROUND. A-B-C PHASE ROTATION (SEE NOTES 1,3,4,5,7) MAXIMUM 10 MIN. @ 125% OF NOMINAL CURRENT.	480Y/277 VAC	1203 A	1503 A
(C) UPS DC LINK TO MODULE BATTERY DISCONNECT. (1) POSITIVE, AND (2) NEGATIVE. (SEE NOTES 5,7,8)	480 VDC	1749 A	2169 A AT END OF DISCHARGE
(J) MODULE BATTERY DISCONNECT TO SYSTEM BATTERY. (1) POSITIVE, AND (2) NEGATIVE AND (3) NEGATIVE FOR CENTER TAP (SEE NOTES 5,7,8)	480 VDC	1749 A	2169 A AT END OF DISCHARGE

DRAWN BY B FISH		SHEET NO 1 OF 1		TITLE ONE - LINE DIAGRAM 1000 KVA / 800 KW PARALLEL MODULE UPS 480 V INPUT - 480 / 277 V OUTPUT SERIES 600	
CHK BY J CAMPBELL		ECN NO		DWG. NO. 97-791686-24	
DES APVL SL68624		REF. DWG.		DATE 06/08/95	
				ORDER NO.	

Liibert
9650 JERONIMO RD.
IRVINE, CALIFORNIA 92718

FILE NAME: SL68624.DWG

Figure 58 One-Line Diagram, System Control Cabinet (SCCA)



NOTES:

1. THE CABLING DISTANCE BETWEEN THE SCCA AND THE SYSTEM SWITCHGEAR MUST NOT EXCEED 25 FT PER NEC 240-21 EXCEPTION #3
2. SCCA RATING IS BASED ON THE NOMINAL FULL LOAD CURRENT RATING OF THE BYPASS BREAKER (SBB). THE SCCA RATING IS TO BE USED IN VOLTAGE DROP CALCULATIONS. VOLTAGE DROP MUST NOT EXCEED 1% OF NOMINAL VOLTAGE.
3. POWER AND CONTROL WIRING TO BE RUN IN SEPARATE CONDUITS.
4. GROUNDING CONDUCTORS TO BE SIZED FOR FULL CAPACITY PER NEC 240-94.
5. ALL WIRING TO BE IN ACCORDANCE WITH NATIONAL AND LOCAL ELECTRICAL CODES.

SCCA RATINGS
1600A
2000A
2500A
3000A
4000A

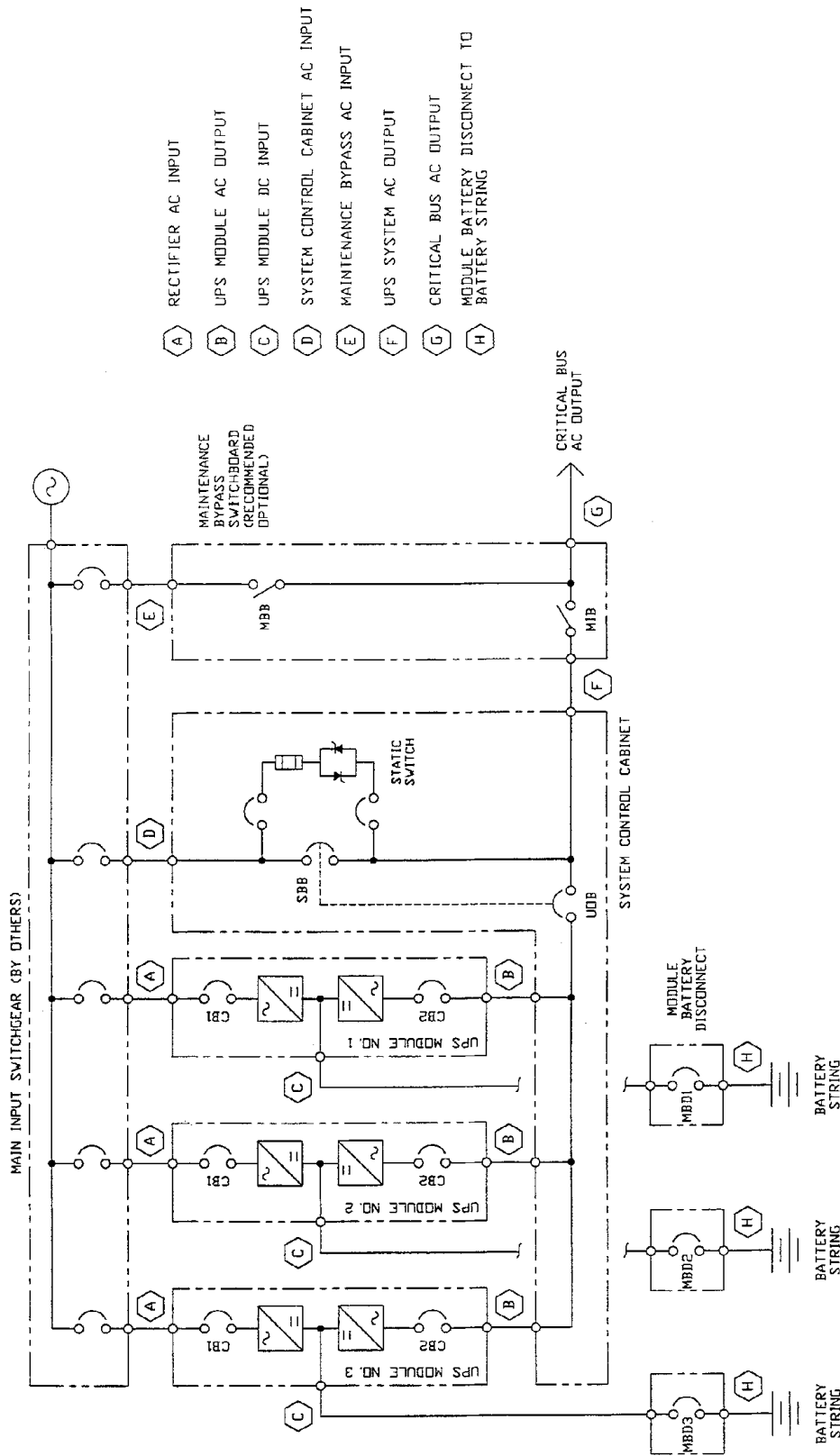
- A** AC INPUT TO SYSTEM CONTROL CABINET.
 3 PHASE, 3 WIRE, & GROUND
 A-B-C ROTATION
 2000A, 2500A, 3000A, 4000A SCCA 480Y/277V
 DR 208Y/120V
- B** AC OUTPUT FROM SYSTEM CONTROL CABINET.
 3 PHASE, 3 WIRE, & GROUND
 A-B-C ROTATION
 2000A, 2500A, 3000A, 4000A SCCA
 480Y/277V DR 208Y/120V

DRAWN BY B FISH		SHEET NO 1 OF 1		TITLE ONE-LINE DIAGRAM SYSTEM CONTROL CABINET	
CHK BY J CAMPBELL		ECN NO		1600 - 4000 AMP STAND ALONE CONFIGURATION (SCCA)	
DES APVL		REF. DWG. SL61431		SERIES 600	
DWG. NO. 97-791614-31		DATE 06/09/95		ORDER NO.	
REV. NO. 1					



FILE NAME: SL61431.DWG

Figure 59 System One-Line Diagram, Three Modules with Two Breaker Maintenance Bypass

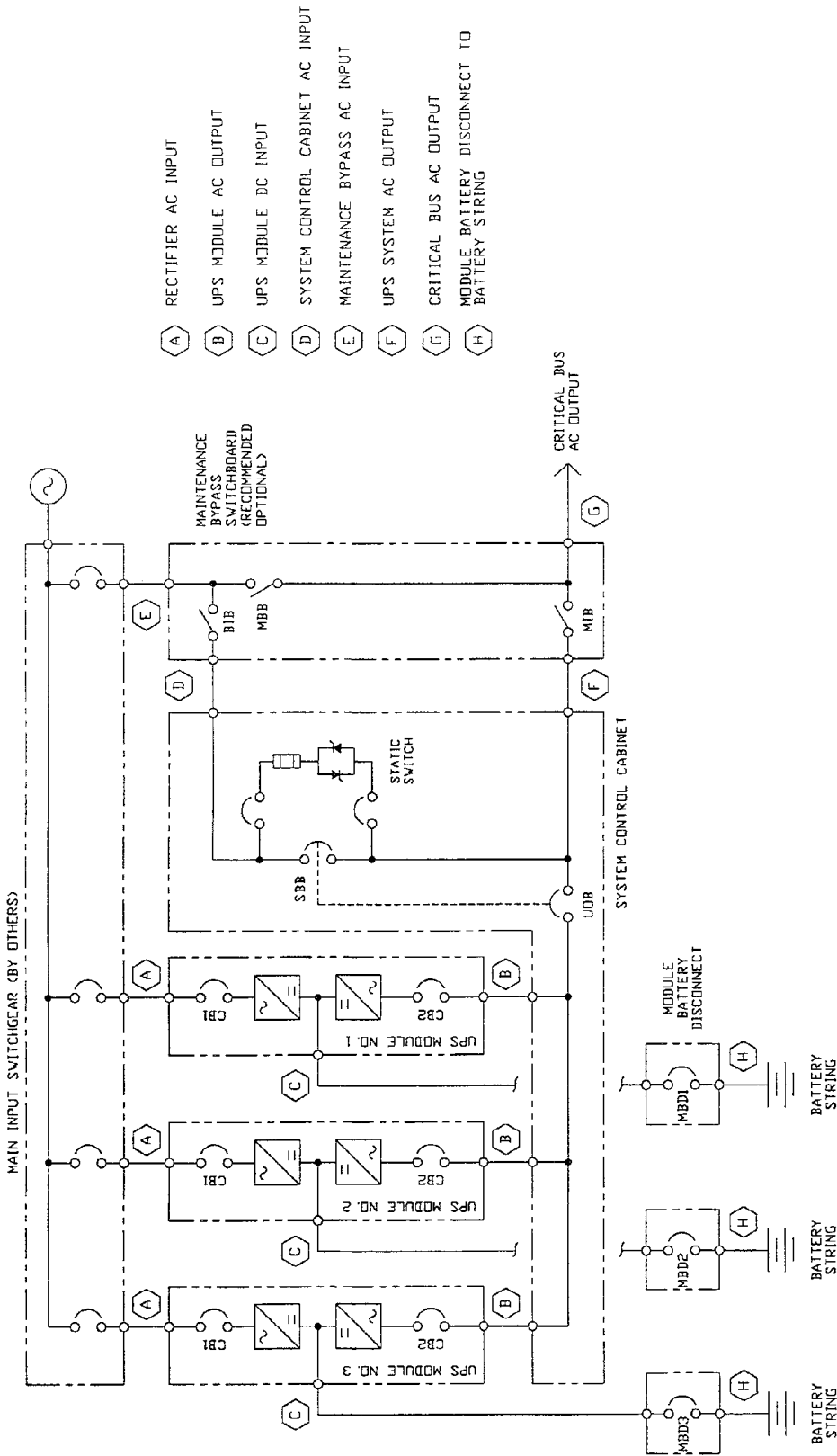


- (A) RECTIFIER AC INPUT
- (B) UPS MODULE AC OUTPUT
- (C) UPS MODULE DC INPUT
- (D) SYSTEM CONTROL CABINET AC INPUT
- (E) MAINTENANCE BYPASS AC INPUT
- (F) UPS SYSTEM AC OUTPUT
- (G) CRITICAL BUS AC OUTPUT
- (H) MODULE BATTERY DISCONNECT TO BATTERY STRING

DRAWN BY B FISH		SHEET NO 1 OF 1		TITLE ONE-LINE DIAGRAM THREE MODULE PARALLEL SYSTEM SCCB WITH TWO BREAKER MAINTENANCE BYPASS SERIES 600	
CHK BY J CAMPBELL		ECN NO		DWG. NO. 97-791614-38	
DES APVL		REF. DWG.		DATE 06/09/95	
		SL6143B		ORDER NO.	
				REV. NO. 1	
				FILE NAME: SL6143B.DWG	



Figure 60 System One-Line Diagram, Three Modules with Three Breaker Maintenance Bypass

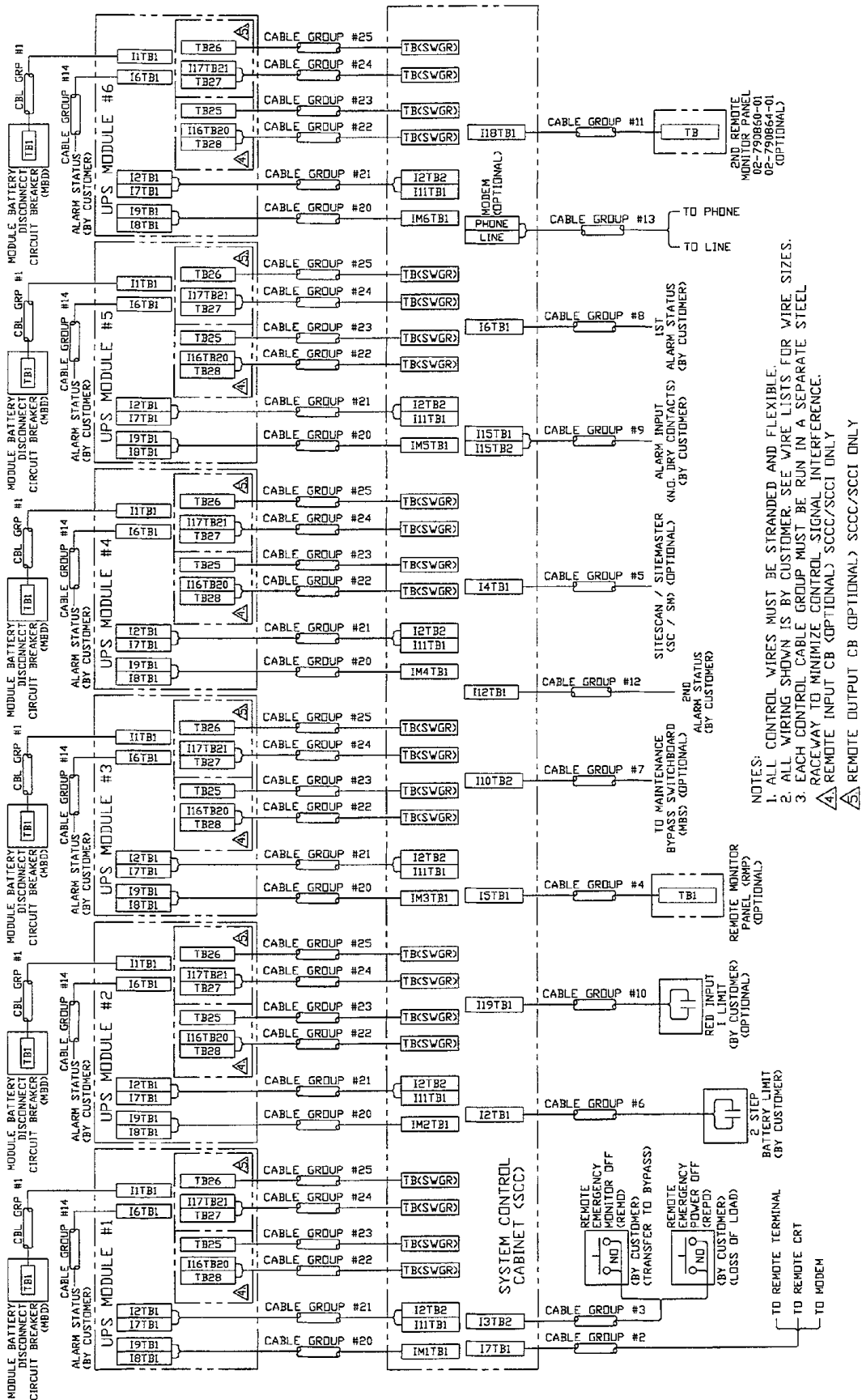


- (A) RECTIFIER AC INPUT
- (B) UPS MODULE AC OUTPUT
- (C) UPS MODULE DC INPUT
- (D) SYSTEM CONTROL CABINET AC INPUT
- (E) MAINTENANCE BYPASS AC INPUT
- (F) UPS SYSTEM AC OUTPUT
- (G) CRITICAL BUS AC OUTPUT
- (H) MODULE BATTERY DISCONNECT TO BATTERY STRING

DRAWN BY B FISH		SHEET NO 1 OF 1		TITLE ONE-LINE DIAGRAM THREE MODULE PARALLEL SYSTEM SCCB WITH THREE BREAKER MAINTENANCE BYPASS SERIES 600	
CHK BY J CAMPBELL		ECN NO		DWG. NO. 97-791614-43	
DES APVL		REF. DWG. SL61443		DATE 06/09/95	
				REV. NO. 1	
				ORDER NO.	
				FILE NAME: S61443.DWG	



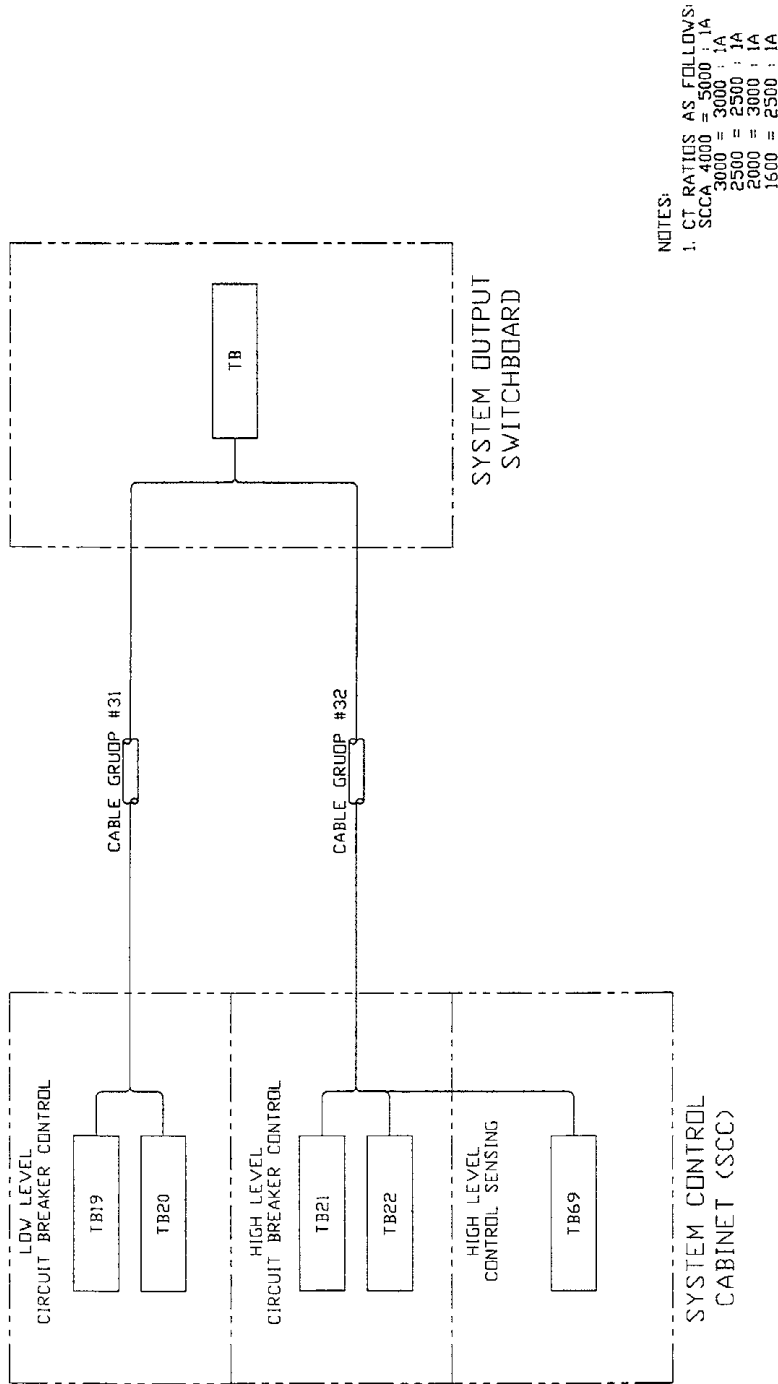
Figure 61 Control Wiring Interconnect Diagram



- NOTES:
1. ALL CONTROL WIRES MUST BE STRANDED AND FLEXIBLE.
 2. ALL WIRING SHOWN IS BY CUSTOMER. SEE WIRE LISTS FOR WIRE SIZES.
 3. EACH CONTROL CABLE GROUP MUST BE RUN IN A SEPARATE STEEL RACEWAY TO MINIMIZE CONTROL SIGNAL INTERFERENCE.
- △ REMOTE INPUT CB (OPTIONAL) SCC/SCCI ONLY
 △ REMOTE OUTPUT CB (OPTIONAL) SCC/SCCI ONLY

 9650 JERONIMO RD. IRVINE, CALIFORNIA 92718		DWG. NO.	DATE
		96-791619-15	01/08/96
CONTROL WIRE LIST INTERCONNECT DIAGRAM MULTIMODULE SYSTEM SERIES 600		REV. NO.	ORDER NO.
		2	
DRAWN BY	SHEET NO	TITLE	
T HECKMAN	1 OF 1	CONTROL WIRE LIST	
CHK BY	ECN NO	INTERCONNECT DIAGRAM	
J CAMPBELL		MULTIMODULE SYSTEM	
DES APVL	REF. DWG.	SERIES 600	
	WD61915		

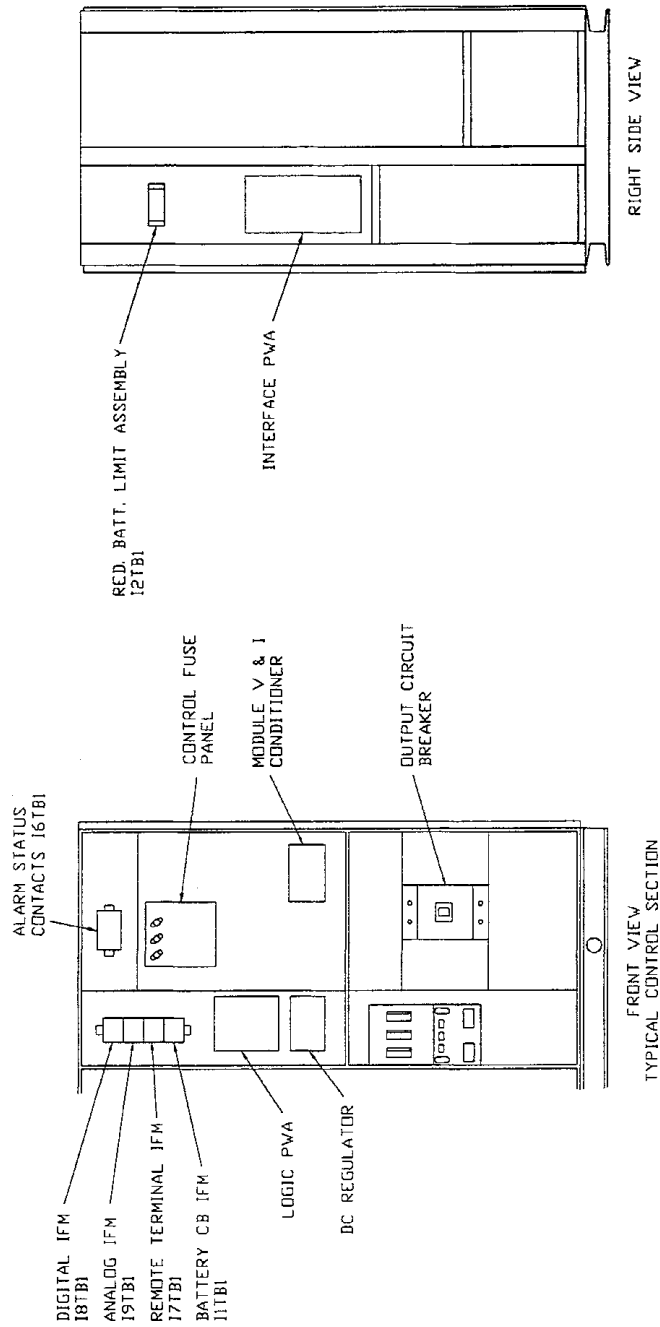
Figure 62 Control Wiring Interconnect Diagram, SCCA and Switchgear




- NOTES:
- CT RATIOS AS FOLLOWS:
 SCCA 4000 = 5000 : 1A
 3000 = 3000 : 1A
 2500 = 2500 : 1A
 2000 = 3000 : 1A
 1500 = 2500 : 1A

DRAWN BY B FISH		SHEET NO 1 OF 1		TITLE CONTROL WIRING DIAGRAM SYSTEM CONTROL CABINET (SCCA) TO SYSTEM SWITCHGEAR INTERCONNECT DIAGRAM (STAND ALONE CONFIGURATION) SERIES 600		DWG. NO. 96-791519-45		DATE 08/16/95	
CHK BY J CAMPBELL		ECN NO		REV. NO. 1		ORDER NO.		Liebert 9650 JERONIMO RD. IRVINE, CALIFORNIA 92718	
DES APVL		REF. DWG. WD61945		FILE NAME: VDB19151.DWG					

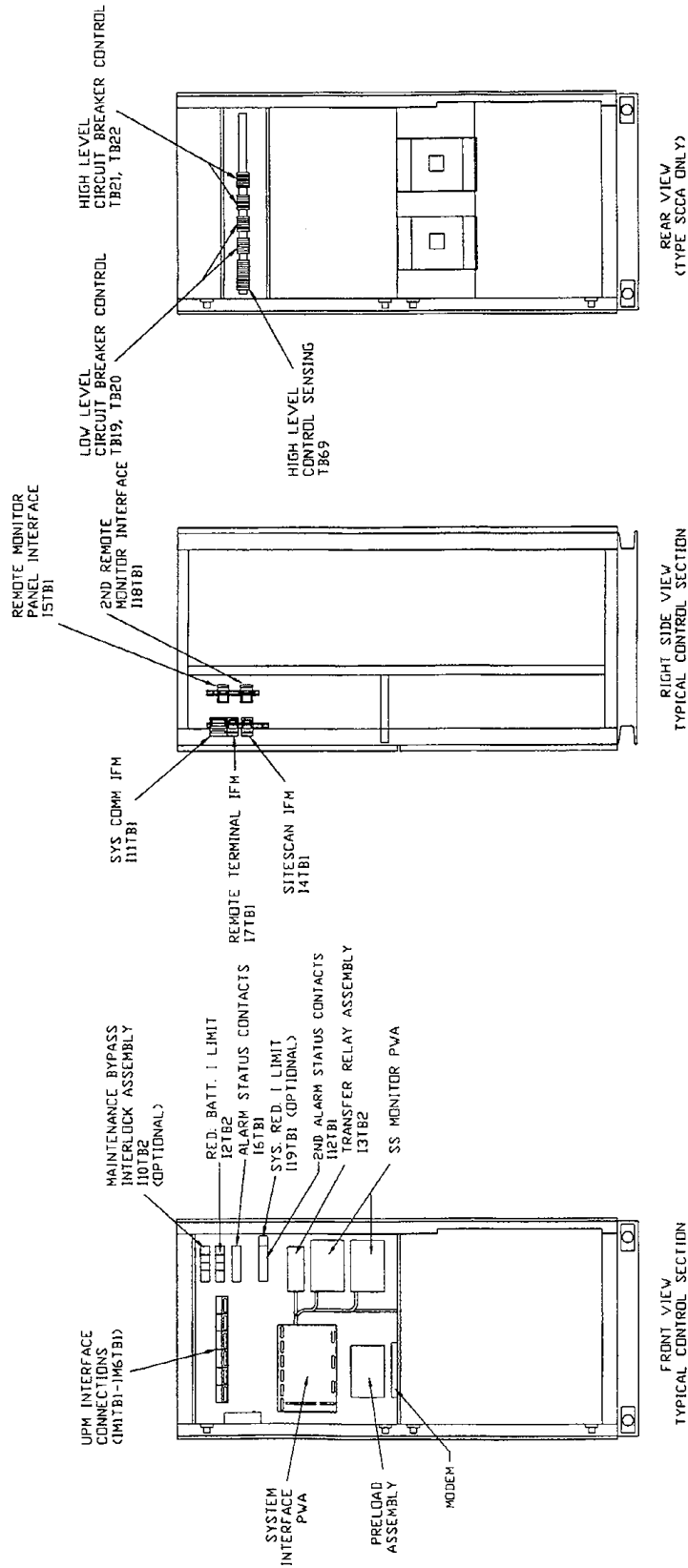
Figure 63 Control Connection Location Diagram, Module



DRAWN BY B FISH		SHEET NO 1 OF 1		TITLE CONTROL CONNECTION LOCATION DIAGRAM 338 (HI-LINK) 750 KVA MULTI-MODULE SYSTEM SERIES 600	
CHK BY J CAMPBELL		ECN NO		DWG. NO. 96-791619-17	DATE 08/16/95
DES APVL		REF. DWG. CC61917		REV. NO. 1	ORDER NO.
 9650 JEROME RD. IRVINE, CALIFORNIA 92718					

FILE NAME: CCG1917.DWG

Figure 64 Control Connection Location Diagram, System Control Cabinet

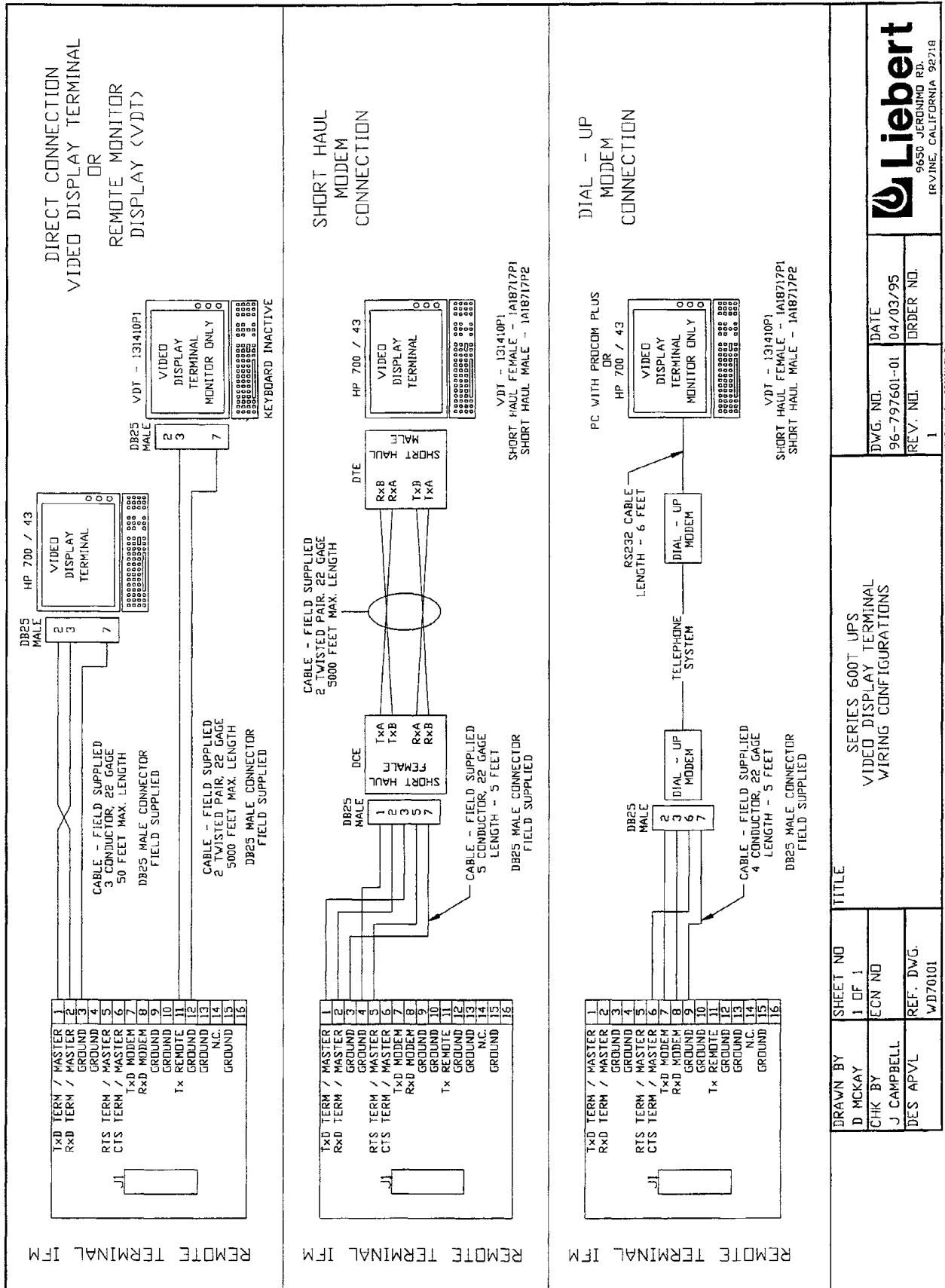


DRAWN BY B FISH		SHEET NO 1 OF 1		TITLE CONTROL CONNECTION LOCATION DIAGRAM SYSTEM CONTROL CABINET SERIES 600	
CHK BY J CAMPBELL		ECN NO		DATE 08/16/95	
DES' APVL CC61918		REF. DWG. CC61918		REV. NO. 1	
				ORDER NO.	



FILE NAME: C69181.DWG

Figure 65 Video Display Terminal Wiring

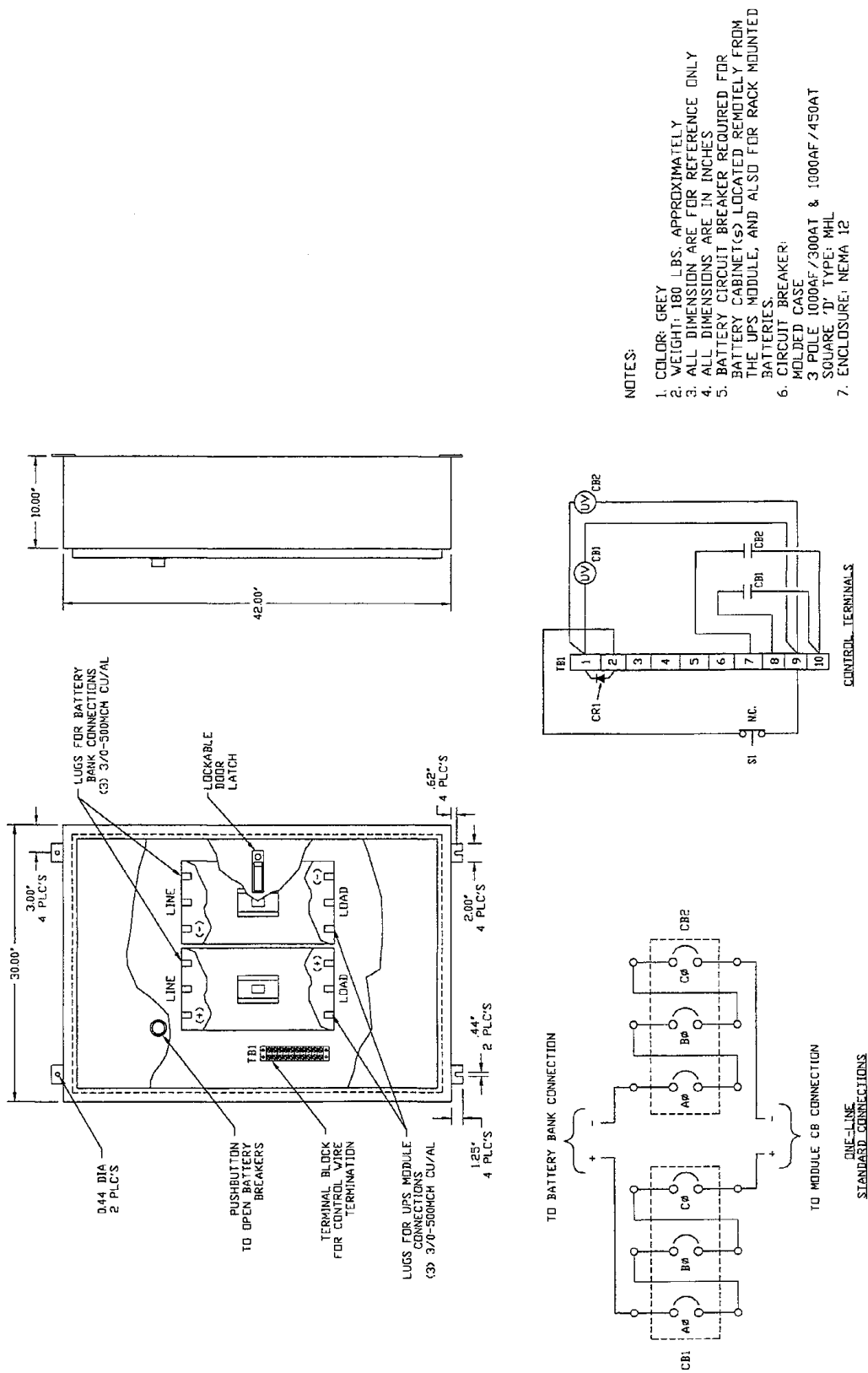


DRAWN BY D. MCKAY		SHEET NO 1 OF 1	TITLE SERIES 600T UPS VIDEO DISPLAY TERMINAL WIRING CONFIGURATIONS	
CHK BY J. CAMPBELL		ECN NO	DWG. NO. 96-797601-01	DATE 04/03/95
DES APVL		REF. DWG. VD70101	REV. NO.	ORDER NO.

1
FILE NAME: VD70101.DWG



Figure 66 Battery Circuit Breaker



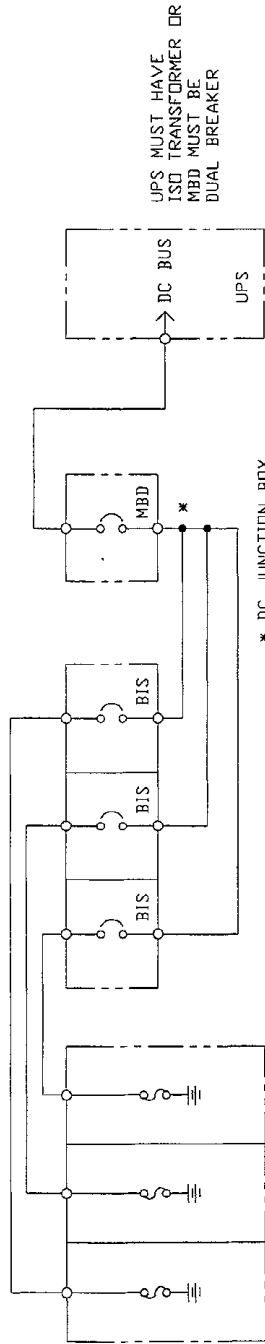
- NOTES:
1. COLOR: GREY
 2. WEIGHT: 180 LBS. APPROXIMATELY
 3. ALL DIMENSIONS ARE FOR REFERENCE ONLY
 4. ALL DIMENSIONS ARE IN INCHES
 5. BATTERY CIRCUIT BREAKER REQUIRED FOR THE UPS MODULE(S) LOCATED REMOTELY FROM BATTERIES.
 6. CIRCUIT BREAKER: MOLDED CASE 3 POLE 1000AF/300AT & 1000AF/450AT SQUARE 'D' TYPE: MHL
 7. ENCLOSURE: NEMA 12

DRAWN BY B. FISH		SHEET NO 1 OF 1		TITLE INSTALLATION DRAWING 1000 AF, 300 AT, AND 1000 AF, 450 AT BATTERY CIRCUIT BREAKER SERIES 600	
CHK BY J. CAMPBELL		ECN NO		DWG. NO. 88-791616-04	
DES APVL		REF. DWG. ING1604		DATE 06/14/95	
				ORDER NO.	
				REV. NO. 1	

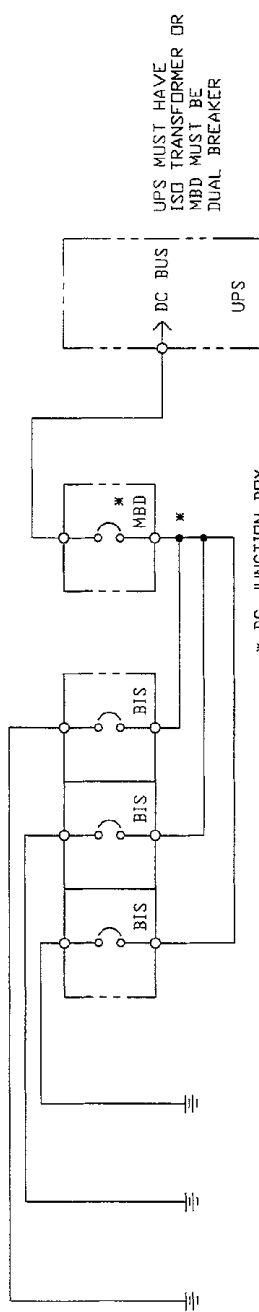
FILE NAME: ING1604.DWG



Figure 67 Parallel Battery Configurations



VENDOR (NON-LIEBERT) BATTERY CABINETS IN TYPICAL PARALLEL STRING CONFIGURATION




RACK MOUNTED BATTERIES IN TYPICAL PARALLEL STRING CONFIGURATION

NOTES:

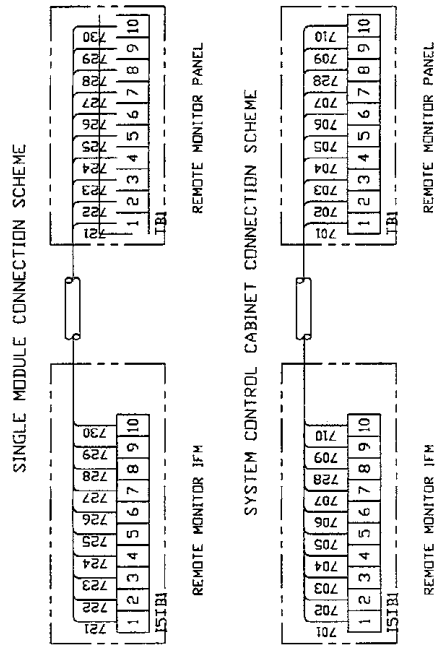
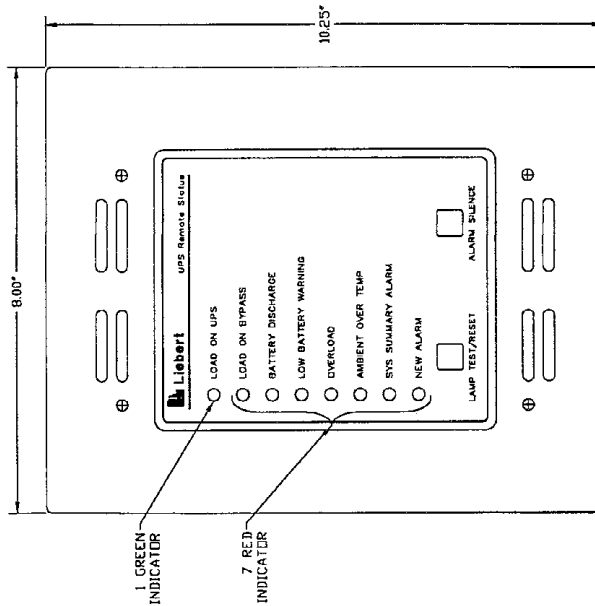
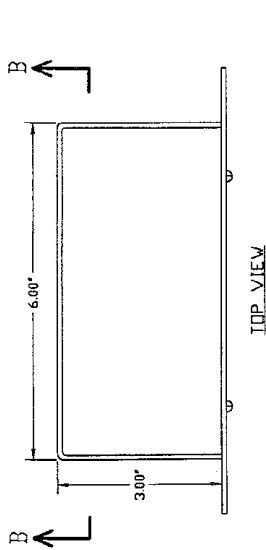
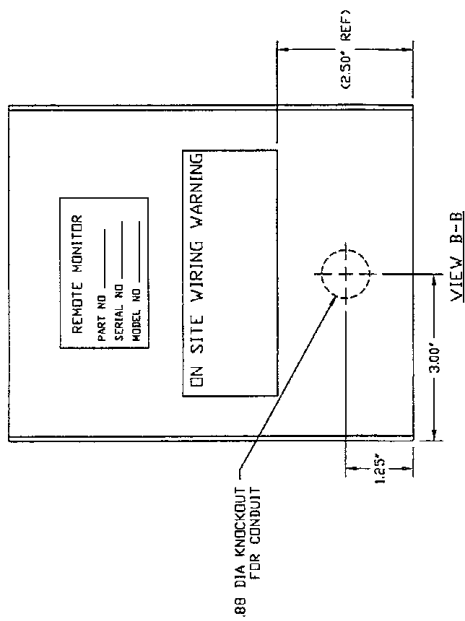
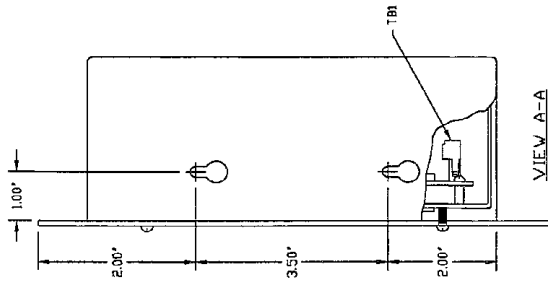
1. A DISCONNECT MEANS (per UL1778) SUCH AS A BATTERY DISCONNECT OR BATTERY ISOLATION SWITCH SHOULD BE PROVIDED FOR EACH PARALLEL STRING OF BATTERIES.

MBD = MODULE BATTERY DISCONNECT
BIS = BATTERY ISOLATION SWITCH

DRAWN BY T. HECKMAN	SHEET NO 1 OF 1	TITLE PARALLEL BATTERY CONFIGURATIONS	
CHK BY J. CAMPBELL	ECN NO	DWG. NO. 88-791616-11	DATE 01/08/96
DES. APVL IN61611	REF. DWG. IN61611	REV. NO. 1	ORDER NO.
		 9650 JEROME RD. IRVINE, CALIFORNIA 92718	

FILE NAME: IN61611.DWG

Figure 68 Remote Status Panel



- NOTES:
1. COLOR: IBM OFF-WHITE
 2. APPROXIMATE WEIGHT: 5 LBS.
 3. NEMA 1 TYPE ENCLOSURE.
 4. ALL DIMENSIONS ARE IN INCHES.

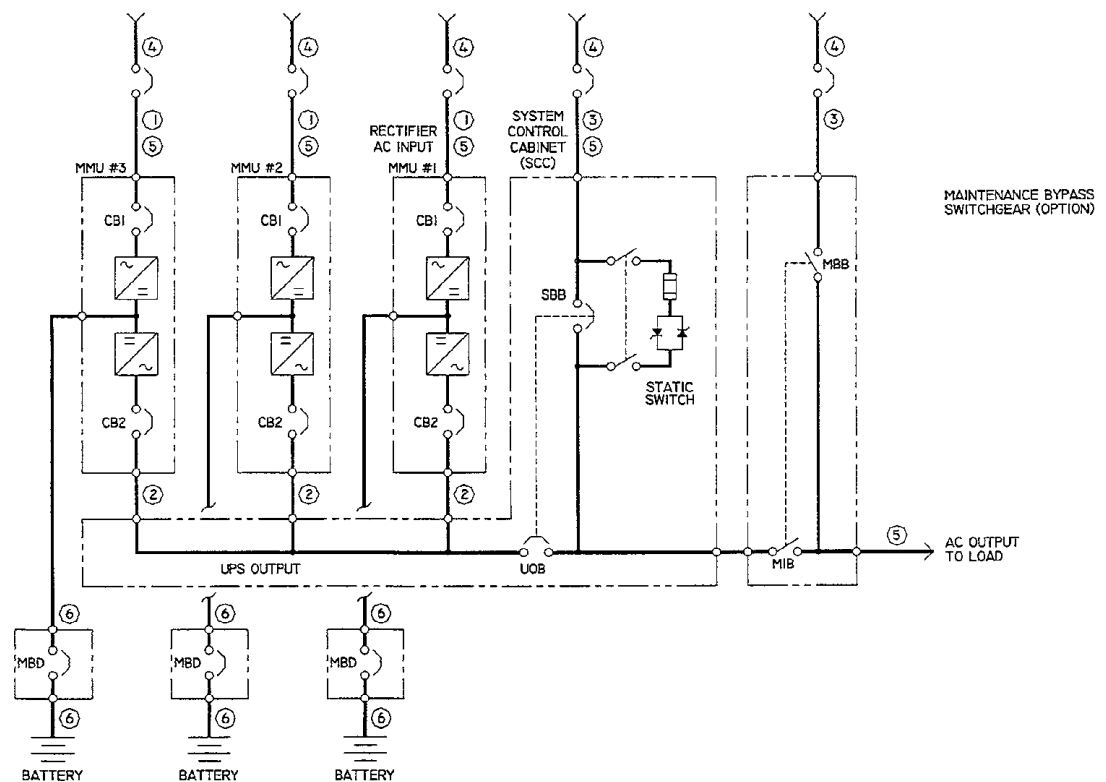
DRAWN BY B FISH		SHEET NO 1 OF 1		TITLE REMOTE STATUS PANEL FLUSH MOUNT SERIES 600	
CHK BY J CAMPBELL		ECN NO		DWG. NO. IN61702	
DES APVL		REF. DWG.		DATE 05/22/95	
		REV. NO. 1		ORDER NO.	
		DWG. NO. 88-791617-02		DATE 05/22/95	
		REV. NO. 1		ORDER NO.	



FILE NAME: IN61702.DWG

10.0 APPENDIX A - SERIES 600 UPS SITE PLANNING DATA

338-1000 kVA Multi-Module Units



10.1 Notes

1. Nominal rectifier AC input current (considered continuous) is based on full rated output load. Maximum current includes nominal input current and maximum battery recharge current (considered noncontinuous). Continuous and noncontinuous current limit are defined in NEC 100. Maximum input current is controlled by current limit setting which is adjustable. Values shown are for maximum setting of 125%. Standard factory setting is 115%.
2. Nominal AC output current (considered continuous) is based on full rated output load. Maximum current includes nominal output current and overload for 10 minutes.
3. Bypass AC input current (considered continuous) is based on full rated output load.
4. Feeder protection (by others in external equipment) for rectifier AC input and bypass AC input is recommended to be provided by separate overcurrent protection devices.
5. UPS output load cables must be run in separate conduit from input cables.
6. Power cable from module DC bus to battery should be sized for a total maximum 2.0 volt line drop (measured at the module) at maximum discharge current.
7. Grounding conductors to be sized per NEC 250-95. A neutral conductor is required from each MMU output to the SCC. Neutral conductors to be sized for full capacity per NEC 310-16, Note 10 for systems with 4-wire loads and half capacity for systems with 3-wire loads.
8. Rectifier AC Input: 3-phase, 3-wire, plus ground.
MMU Output to System Control Cabinet: 3-phase, 4-wire, plus ground.
Bypass AC Input and AC Output to Load: 3-phase, 3 or 4-wire, plus ground.
Module DC Input from Battery: 2-wire, (positive and negative).
9. All wiring is to be in accordance with National and Local Electrical Codes.
10. Minimum clearance is 2 feet above UPS.
11. Top or bottom cable entry through removable access plates. Cut plate to suit conduit size.
12. Control wiring and power cables must be run in separate conduits. Control wiring must be stranded conductors.
13. UPS module will be shipped in sections. Reconnect shipping splits according to drawings supplied with the equipment.

Table 4 338-1000 kVA Multi-Module Unit, 480 Volt - Standard Module

UPS Rating		* Rectifier AC Input Current		Inverter AC Output Current		Required Battery Disconnect Rating	Maximum Battery Current at End of Discharge	% Efficiency at Full Load	Maximum Heat Dissipation BTU/hr.	Dimensions Inches	Approx. Weight Lb.	Floor Loading Lbs./Sq.Ft.
kVA	kW	Nom	Max	Nom	Max	Amperes	Amperes		Full Load	(WxDxH)	(Un-packed)	(Distributed Loading)
338	270	420	525	406	507	1000	993	92	80131	128x38x78	8300	246
400	320	504	630	481	601	1200	1170	92	94970	164x38x78	9900	229
400	360	560	700	481	601	1200	1316	92	106842	164x38x78	9900	229
500	400	630	788	601	752	1600	1463	92	118713	164x38x78	10600	245
500	450	700	875	601	752	1600	1646	92	133552	164x38x78	10600	245
625	500	778	973	752	940	2000	1828	92	148391	164x41x78	12300	263
750 ^{HL}	600	934	1167	902	1128	1600	1644	92	178070	164x41x78	13925	298
750 ^{LL}	600	934	1167	902	1128	2000	2194	92	178070	177x44x82	14600	270
1000	800	1217	1522	1203	1504	2500	2169	93	205514	177x44x82	16555	306
1000	900	1369	1712	1203	1504	2500	2440	93	231203	177x44x82	16555	306
Applicable Notes:		1,4,5,7,8,9,11,12		2,5,7,8,9,11,12		6	6,8,9,11,12	—	—	13	13	—

For explanation of notes, see referenced numbers in 10.1 - Notes

* Nominal Input Power Factor 0.85 lagging at full load; 9% Maximum Total Input Harmonic Current Distortion (THD) at full load.

HL - 750 kVA module with 240 battery cells

LL - 750 kVA module with 180 battery cells

Table 5 338-1000 kVA Multi-Module Unit, 480 Volt - Standard Module With Optional Low Distortion Input Filter

UPS Rating		* Rectifier AC Input Current		Inverter AC Output Current		Required Battery Disconnect Rating	Maximum Battery Current at End of Discharge	% Efficiency at Full Load	Maximum Heat Dissipation BTU/hr.	Dimensions Inches	Approx. Weight Lb.	Floor Loading Lbs./Sq.Ft.
kVA	kW	Nom	Max	Nom	Max	Amperes	Amperes		Full Load	(WxDxH)	(Un-packed)	(Distributed Loading)
338	270	380	474	406	507	1000	993	92	80131	128x38x78	8700	258
400	320	455	568	481	601	1200	1170	92	94970	164x38x78	10300	238
400	360	512	639	481	601	1200	1316	92	106842	164x38x78	10300	238
500	400	562	703	601	752	1600	1463	92	118713	164x38x78	11150	258
500	450	633	791	601	752	1600	1646	92	133552	164x38x78	11150	258
625	500	711	888	752	940	2000	1828	92	148391	164x41x78	12950	277
750 ^{HL}	600	853	1066	902	1128	1600	1644	92	178070	164x41x78	14200	304
750 ^{LL}	600	853	1066	902	1128	2000	2194	92	178070	177x44x82	15450	286
1000	800	1125	1406	1203	1504	2500	2169	93	205514	177x44x82	17400	322
1000	900	1265	1582	1203	1504	2500	2440	93	231203	177x44x82	17400	322
Applicable Notes:		1,4,5,7,8,9,11,12		2,5,7,8,9,11,12		6	6,8,9,11,12	—	—	13	13	—

For explanation of notes, see referenced numbers in 10.1 - Notes

* Nominal Input Power Factor 0.92 lagging at full load; 4% Maximum Total Input Harmonic Current Distortion (THD) at full load.

HL - 750 kVA module with 240 battery cells

LL - 750 kVA module with 180 battery cells

Table 6 338-500 kVA Multi-Module Unit, 208 Volt - Standard Module

UPS Rating		* Rectifier AC Input Current		Inverter AC Output Current		Required Battery Disconnect Rating	Maximum Battery Current at End of Discharge	% Efficiency at Full Load	Maximum Heat Dissipation BTU/hr.	Dimensions Inches	Approx. Weight Lb.	Floor Loading Lb./ Sq.Ft.
kVA	kW	Nom	Max	Nom	Max	Amperes	Amperes		Full Load	(WxDxH)	(Un-packed)	(Distributed Loading)
338	270	980	1226	937	1171	1000	998	92	91138	128x38x78	8600	255
400	320	1170	1462	1110	1388	1200	1176	92	101457	218x38x78	10250	214
400	360	1300	1625	1110	1388	1200	1323	92	114140	218x38x78	10250	214
500	400	1462	1827	1388	1735	1600	1470	92	126822	218x38x78	10950	228
500	450	1625	2031	1388	1735	1600	1654	92	142675	218x38x78	10950	228
Applicable Notes:		1,4,5,7,8,9,11,12		2,5,7,8,9,11,12		6	6,8,9,11,12	—	—	13	13	—

For explanation of notes, see referenced numbers in **10.1 - Notes**

* Nominal Input Power Factor 0.85 lagging at full load; 9% Maximum Total Input Harmonic Current Distortion (THD) at full load.

Table 7 338-500 kVA Multi-Module Unit, 208 Volt - Standard Module With Optional Low Distortion Input Filter

UPS Rating		* Rectifier AC Input Current		Inverter AC Output Current		Required Battery Disconnect Rating	Maximum Battery Current at End of Discharge	% Efficiency at Full Load	Maximum Heat Dissipation BTU/hr.	Dimensions Inches	Approx. Weight Lb.	Floor Loading Lb./ Sq.Ft.
kVA	kW	Nom	Max	Nom	Max	Amperes	Amperes		Full Load	(WxDxH)	(Un-packed)	(Distributed Loading)
338	270	895	1119	937	1171	1000	998	92	91138	128x38x78	9100	270
400	320	1055	1319	1110	1388	1200	1176	92	101457	218x38x78	10750	224
400	360	1187	1484	1110	1388	1200	1323	92	114140	218x38x78	10750	224
500	400	1333	1667	1388	1735	1600	1470	92	126822	218x38x78	11650	243
500	450	1500	1875	1388	1735	1600	1654	92	142675	218x38x78	11650	243
Applicable Notes:		1,4,5,7,8,9,11,12		2,5,7,8,9,11,12		6	6,8,9,11,12	—	—	13	13	—

For explanation of notes, see referenced numbers in **10.1 - Notes**

* Nominal Input Power Factor 0.92 lagging at full load; 4% Maximum Total Input Harmonic Current Distortion (THD) at full load.



Table 8 338-1000 kVA Multi-Module Unit, 600 Volt - Standard Module

UPS Rating		* Rectifier AC Input Current		Inverter AC Output Current		Required Battery Disconnect Rating	Maximum Battery Current at End of Discharge	% Efficiency at Full Load	Maximum Heat Dissipation BTU/hr.	Dimensions Inches	Approx. Weight Lb.	Floor Loading Lb./Sq.Ft.
kVA	kW	Nom	Max	Nom	Max	Amperes	Amperes		Full Load	(WxDxH)	(Un-packed)	(Distributed Loading)
338	270	336	420	325	406	1000	993	92	80131	128x38x78	8300	246
400	320	403	504	385	481	1200	1170	92	94970	164x38x78	9900	229
400	360	448	560	385	481	1200	1316	92	106842	164x38x78	9900	229
500	400	504	630	481	601	1600	1463	92	118713	164x38x78	10600	245
500	450	567	709	481	601	1600	1646	92	133552	164x38x78	10600	245
625	500	630	788	601	752	2000	1828	92	148391	164x41x78	12300	263
750 ^{HL}	600	747	934	722	902	1600	1644	92	178070	164x41x78	13925	298
750 ^{LL}	600	747	934	722	902	2000	2194	92	178070	177x44x82	14600	270
1000	800	974	1217	962	1203	2500	2169	93	205514	177x44x82	16555	306
1000	900	1096	1369	962	1203	2500	2440	93	231203	177x44x82	16555	306
Applicable Notes:		1,4,5,7,8,9,11,12		2,5,7,8,9,11,12		6	6,8,9,11,12	—	—	13	13	—

For explanation of notes, see referenced numbers in 10.1 - Notes

* Nominal Input Power Factor 0.85 lagging at full load; 9% Maximum Total Input Harmonic Current Distortion (THD) at full load.

HL - 750 kVA module with 240 battery cells

LL - 750 kVA module with 180 battery cells

Table 9 338-1000 kVA Multi-Module Unit, 600 Volt - Standard Module With Optional Low Distortion Input Filter

UPS Rating		* Rectifier AC Input Current		Inverter AC Output Current		Required Battery Disconnect Rating	Maximum Battery Current at End of Discharge	% Efficiency at Full Load	Maximum Heat Dissipation BTU/hr.	Dimensions Inches	Approx. Weight Lb.	Floor Loading Lb./Sq.Ft.
kVA	kW	Nom	Max	Nom	Max	Amperes	Amperes		Full Load	(WxDxH)	(Un-packed)	(Distributed Loading)
338	270	307	384	325	406	1000	993	92	80131	128x38x78	8700	258
400	320	360	450	385	481	1200	1170	92	94970	164x38x78	10300	238
400	360	405	506	385	481	1200	1316	92	106842	164x38x78	10300	238
500	400	460	575	481	601	1600	1463	92	118713	164x38x78	11150	258
500	450	517	647	481	601	1600	1646	92	133552	164x38x78	11150	258
625	500	575	718	601	752	2000	1828	92	148391	164x41x78	12950	277
750 ^{HL}	600	682	853	722	902	1600	1644	92	178070	164x41x78	14200	304
750 ^{LL}	600	682	853	722	902	2000	2194	92	178070	177x44x82	15450	286
1000	800	890	1113	962	1203	2500	2169	93	205514	177x44x82	17400	322
1000	900	1012	1265	962	1203	2500	2440	93	231203	177x44x82	17400	322
Applicable Notes:		1,4,5,7,8,9,11,12		2,5,7,8,9,11,12		6	6,8,9,11,12	—	—	13	13	—

For explanation of notes, see referenced numbers in 10.1 - Notes

* Nominal Input Power Factor 0.92 lagging at full load; 4% Maximum Total Input Harmonic Current Distortion (THD) at full load.

HL - 750 kVA module with 240 battery cells

LL - 750 kVA module with 180 battery cells

Series 600™ UPS

**Multi-Module Three Phase
338 kVA to 1000 kVA; 60 Hz**

Technical Support

U.S.A. 1-800-222-5877
Outside the U.S.A. 614-841-6755
U.K. +44 (0) 1793 553355
France +33 1 4 87 51 52
Germany +49 89 99 19 220
Italy +39 2 98250 1
Netherlands +00 31 475 503333
E-mail upstech@liebert.com
Web site <http://www.liebert.com>
Worldwide FAX 614-841-5471
tech support

The Company Behind The Products

With more than 500,000 installations around the globe, Liebert is the world leader in computer protection systems. Since its founding in 1965, Liebert has developed a complete range of support and protection systems for sensitive electronics:

- Environmental systems: close-control air conditioning from 1.5 to 60 tons.
- Power conditioning and UPS with power ranges from 250 VA to more than 1000 kVA.
- Integrated systems that provide both environmental and power protection in a single, flexible package.
- Monitoring and control — on-site or remote — from systems of any size or location

Service and support, through more than 100 service centers around the world, and a 24-hour Customer Response Center.

While every precaution has been taken to ensure accuracy and completeness of this literature, Liebert Corporation assumes no responsibility, and disclaims all liability for damages resulting from use of this information or for any errors or omissions.

© 1998 Liebert Corporation. All rights reserved throughout the world. Specifications subject to change without notice.

® Liebert and the Liebert logo are registered trademarks of Liebert Corporation. All names referred to are trademarks or registered trademarks of their respective owners.

Printed in U.S.A.

SL-24495