

**DISCONTINUED
PRODUCT**

■ AC Power
For Business-Critical Continuity™

Liebert® Npower™ UPS

Operation & Maintenance Manual—30-130kVA, 60Hz, Single Module System



EMERSON
Network Power

UPS COMPONENT SERVICE LIFE

Your Liebert® UPS is designed to provide years of trouble-free operation. Some components, however, require periodic replacement.

Emerson recommends periodic inspection of the components in **Table i** and replacement before they reach the end of their expected service life.

Table i UPS component service life

Component	Expected Life	Replace In:
Power AC Filter Capacitors	> 7 years	5 to 6 years
Power DC Filter Capacitors	> 7 years	5 to 6 years
Low Profile Fans	> 7 years	5 to 6 years
Air Filters	1 to 3 years	As needed—Check four times per year
Lithium Battery for Logic Memory Backup	10 years	8 to 9 years
Valve-Regulated, Lead-Acid (VRLA) Storage Batteries	5 years	3 to 4 years
	10 years	6 to 8 years

NOTICE

Failure to replace these components within the recommended times might result in system failure, down time and significant damage to your unit and other property.

Do not substitute components except as authorized by Emerson. Unauthorized substitutions could reduce system performance and may invalidate agency listings.



WARNING

Risk of electric shock. Can cause equipment damage, injury or death.

Service and maintenance work must be performed only by properly trained and qualified personnel and in accordance with applicable regulations as well as with manufacturers' specifications. Some areas inside a UPS units and battery cabinets remain potentially lethal even when power has been removed. Never remove or open doors or unit skins to expose yourself to interior components.

Disposal of Used Components

Some components that have a limited lifespan are considered hazardous material. Dispose of all replaced components in accordance with local laws and regulations. If you are uncertain of how to dispose of these components please discuss with your Emerson Customer Engineer or contact Emerson Network Power Liebert Services at 1-800-LIEBERT (1-800-543-2378).

TABLE OF CONTENTS

UPS COMPONENT SERVICE LIFE	INSIDE FRONT COVER
IMPORTANT SAFETY INSTRUCTIONS	1
OVERVIEW OF MANUAL	2
1.0 INTRODUCTION	3
1.1 System Description	3
1.1.1 Reliability	4
1.1.2 Versatility	4
1.2 Safety Precautions	4
1.3 Modes Of Operation	5
1.3.1 Normal (Load On UPS)	5
1.3.2 Input Power Failure	5
1.3.3 Recharge	5
1.3.4 Overload	6
1.3.5 Bypass (Internal)	6
1.3.6 External Maintenance Bypass	6
1.3.7 Off-Battery	6
1.4 Operator Controls	7
1.5 Options	7
2.0 THEORY OF OPERATION	8
2.1 General Component Description	8
2.1.1 UPS Module	8
2.1.2 Battery System	8
2.2 Detailed Component Descriptions	9
2.2.1 Controls	9
2.2.2 Rectifier/Charger	10
2.2.3 Battery Charging Circuit	10
2.2.4 Inverter	11
2.2.5 Static Bypass Switch	12
3.0 OPERATION	14
3.1 Operator Controls	14
3.1.1 Operator Control Panel	16
3.1.2 Navigation Buttons	16
3.1.3 Rotary Switch	17
3.2 Security Access and Passwords	18
3.3 Display Screens and Procedures	19
3.3.1 Mimic Display Screen	21
3.3.2 Startup	27
3.3.3 Shutdown	34
3.3.4 Status Reports	35
3.3.5 Configuration Screens	40
3.3.6 Manual Transfer	58
3.3.7 Battery Management	59
3.3.8 Auto Restart	69
3.3.9 System Status Monitoring	70

3.4	Faults, Alarms, Status	73
3.4.1	Faults	73
3.4.2	Alarms	74
3.4.3	Status	90
3.5	Communication Interfaces	90
3.5.1	RS-232 Port: Local Reporting Terminal	91
3.5.2	Worldwide Reporting	91
3.5.3	Remote Alarm Status Panel	93
3.5.4	Liebert SiteScan	93
3.5.5	Setting Up External Communication Devices	94
3.6	Modes of Operation	94
3.6.1	Load on Bypass	94
3.6.2	OK to Transfer	94
3.6.3	Momentary Overloads	95
3.6.4	Input Power Failure (Load on Battery)	95
3.6.5	Automatic Operations	96
4.0	MAINTENANCE	98
4.1	Safety Precautions	98
4.2	Routine Maintenance	99
4.2.1	Record Log	99
4.2.2	Air Filters	99
4.2.3	Battery Maintenance	99
4.2.4	Battery Safety Precautions	100
4.2.5	Torque Requirements	101
4.3	Detecting Trouble	102
4.4	Reporting a Problem	102
4.5	Corrective Actions	102
4.6	Recommended Test Equipment	102

DISCONTINUED
PRODUCT

FIGURES

Figure 1	UPS controls and display screen (with example of the monitor/mimic screen)	6
Figure 2	80 kVA UPS outside and inside views	14
Figure 3	Operator control panel	15
Figure 4	Navigation buttons	16
Figure 5	Rotary switch.	17
Figure 6	Configuration screen.	18
Figure 7	User settings screen, page 6	18
Figure 8	Menu tree	19
Figure 9	Main menu screen.	21
Figure 10	Monitor / mimic display screen example: normal power flow.	21
Figure 11	Mimic display screen example: utility fail.	22
Figure 12	Mimic display screen example: load on bypass, UPS module on and charging battery	22
Figure 13	Monitor / mimic display screen example: load on bypass, UPS module off, service mode	23
Figure 14	Mimic display screen detail	23
Figure 15	Input status screen	24
Figure 16	DC bus / battery status.	24
Figure 17	Bypass input status	25
Figure 18	Output load status screen.	25
Figure 19	Active faults and alarms screen	26
Figure 20	Active faults and alarms, loss of power	26
Figure 21	System ratings screen.	27
Figure 22	Mimic display screen with load on bypass and switches closed	27
Figure 23	Startup / shutdown procedures screen.	28
Figure 24	Manual startup screen, close static switch contactors screen	29
Figure 25	Target and ramp values	29
Figure 26	DC bus setpoint screen	30
Figure 27	External maintenance bypass switch, dual-input UPS	31
Figure 28	External maintenance bypass switch, single-input UPS	31
Figure 29	Set number of battery cabinets screen.	33
Figure 30	User shutdown screen.	34
Figure 31	Manual transfer / retransfer screen when transfer is allowed.	34
Figure 32	Manual transfer / retransfer screen when transfer is not allowed	35
Figure 33	Status report screen	35
Figure 34	Event log report screen showing most recent event.	36
Figure 35	Event log report screen showing previous event.	36
Figure 36	Event log report screen showing previous event.	36
Figure 37	History log metering report screen	37
Figure 38	History log status report screen.	38
Figure 39	History log faults/alarms report screen.	39
Figure 40	Configuration screen	40
Figure 41	System ratings, page 1	41
Figure 42	System ratings, page 2	41
Figure 43	System settings screen, page 1.	42
Figure 44	Date setting screen	42
Figure 45	Time setting screen.	43
Figure 46	System settings, page 2	43
Figure 47	System settings, page 3	44
Figure 48	Enter password screen	44
Figure 49	Single /dual input screen	44

Figure 50	Options screen, page 1	45
Figure 51	10% passive filter settings screen	45
Figure 52	Options screen, page 2	46
Figure 53	Options screen, page 3	46
Figure 54	Options screen, page 4	46
Figure 55	Communication options Screen, page 1	47
Figure 56	Auto dial screen.	47
Figure 57	Modem selection screen	47
Figure 58	Auto dial screen, page 2	48
Figure 59	Pager support configuration	48
Figure 60	Communications options screen, page 2	49
Figure 61	User settings screen, page 1	49
Figure 62	User settings screen, page 2	49
Figure 63	User settings screen, page 3	50
Figure 64	User settings screen, Page 4	50
Figure 65	User settings screen, page 5	50
Figure 66	10% Passive filter settings screen	51
Figure 67	User settings screen, page 6	51
Figure 68	Factory settings screen	51
Figure 69	Factory settings screen, page 2	52
Figure 70	Factory settings screen, page 3	52
Figure 71	Alarm / fault name screen	53
Figure 72	Alarm edit screen	53
Figure 73	Customer alarm interface screen	55
Figure 74	Customer alarm interface screen, page 2	55
Figure 75	Programmable output relay board #1, AS400 assignment	55
Figure 76	Relay assignments	56
Figure 77	Programmable output relay board, standard set	56
Figure 78	Programmable output relay board, standard set, page 2	56
Figure 79	Programmable output relay board, user defined	57
Figure 80	List of alarm faults screen	57
Figure 81	Manual transfer / retransfer screen when transfer is allowed	59
Figure 82	Manual transfer / retransfer screen when transfer is not allowed	59
Figure 83	Battery management screen	59
Figure 84	Battery test screen	60
Figure 85	Automatic test screen	61
Figure 86	Set battery cycle screen	61
Figure 87	Set battery duration screen	61
Figure 88	Battery equalizer screen	62
Figure 89	Auto screen	62
Figure 90	Manual screen	63
Figure 91	Equalize time period screen	63
Figure 92	Equalize voltage screen	63
Figure 93	Battery temperature compensation charge screen	64
Figure 94	Battery temperature compensation enable/disable screen	64
Figure 95	Battery temperature compensation charge screen, page 2	64
Figure 96	Battery temp compensation edit screen	65
Figure 97	Battery cycle monitor screen	65
Figure 98	Battery cycle monitor screen, page 2	66
Figure 99	0-30 seconds discharge cycles	66

Figure 100	Summary page screen	67
Figure 101	User settings, page 2	68
Figure 102	Battery time low warning screen	68
Figure 103	Auto restart setting screen	69
Figure 104	Auto restart screen layout	69
Figure 105	System status screen	71
Figure 106	System status screen, page 2	71
Figure 107	System status screen, page 3	71
Figure 108	System status screen, page 4	72
Figure 109	Summary alarm in active position screen	75
Figure 110	Summary alarm editing screen	75
Figure 111	Pager support screen	92
Figure 112	Load on bypass, UPS not available	94
Figure 113	Load on bypass (UPS available and battery charging)	95
Figure 114	Utility fail, load on battery	95

TABLES

Table i	UPS component service life	Inside Front Cover
Table 1	Key locations on UPS	14
Table 2	Key locations on operator control panel	15
Table 3	External maintenance bypass switch positions and actions	31
Table 4	External maintenance switch configuration options	32
Table 5	Default time settings	60
Table 6	Abbreviations used in alarm messages	75
Table 7	Alarms, functions, and corrective actions	76
Table 8	Service terminal command summary	91
Table 9	Battery voltage record	101
Table 10	Circuit breakers with compression lugs (for power wiring)	101
Table 11	Terminal block with compression lugs (for control wiring)	101
Table 12	Recommended test equipment and tools	102

DISCONTINUED
PRODUCT

IMPORTANT SAFETY INSTRUCTIONS

SAVE THESE INSTRUCTIONS.

This manual contains important instructions that should be followed during maintenance of your Liebert® Npower™ UPS and batteries.

WARNING

Exercise extreme care when handling UPS cabinets to avoid equipment damage or injury to personnel. Refer to separate installation manual for equipment handling information and installation procedures.

Follow all battery safety precautions in **4.0 - Maintenance** when installing, charging, or servicing batteries. In addition to the hazard of electric shock, gas produced by batteries can be explosive and sulfuric acid can cause severe burns.

In case of fire involving electrical equipment, use only carbon dioxide fire extinguishers or others approved for use in electrical fire fighting.

Extreme caution is required when performing maintenance.

Be constantly aware that the UPS contains high DC as well as AC voltages. With input power off and the battery disconnected, high voltage at filter capacitors and power circuits should be discharged within 30 seconds. However, if a power circuit failure has occurred, you should assume that high voltage may still exist after shutdown. Check with a voltmeter before making contact.

AC voltage will remain on the system bypass, the UPS output terminals and the static bypass switch, unless associated external circuit breakers are opened.

Check for voltage with both AC and DC voltmeters prior to making contact.

When the UPS system is under power, both the operator and any test equipment must be isolated from direct contact with earth ground and the UPS chassis frame by using rubber mats.

Some components within the cabinets are not connected to chassis ground. Any contact between floating circuits and the chassis is a lethal shock hazard. Exercise caution that the test instrument exterior does not make contact either physically or electrically with earth ground.

ELECTROMAGNETIC COMPATIBILITY—The Liebert Npower complies with the limits for a Class A Digital Device, pursuant to Part 15 of FCC rules. Operation is subject to the following two conditions:

- This device may not cause harmful interference, and
- This device must accept any interference received, including interference that may cause undesired operation.

Operating this device in a residential area is likely to cause harmful interference that users must correct at their own expense.

The Liebert Npower complies with the requirements of EMC Directive 2004/108/EC and the published technical standards. Continued compliance requires installation in accordance with these instructions and use of accessories approved by Emerson®.

OVERVIEW OF MANUAL

The Liebert® Npower™ manual is organized so that information can be found quickly. Each major topic is separated by sections, and there is a Table of Contents for each section. The names of the sections and their contents are described below.

Section 1 - INTRODUCTION is a summary of the Liebert® Npower™ Uninterruptible Power System (UPS). It describes some of the unique features and benefits of the Liebert Npower UPS, as well as the design principles and standards that Liebert follows in the manufacture of each system. A description of the Liebert Npower system and an overview of its functions are also included.

Section 2 - THEORY OF OPERATION is an explanation of the major circuit groups of the Liebert Npower UPS. This section is for individuals who want to know both the basics and the specifics of each major component. The text explains how the UPS handles electrical disturbances and interruptions.

Section 3 - OPERATION is written for facility personnel responsible for the operation of the system. It details the procedures required to start-up the system, to transfer the load between the available sources, and to shut down the system. Both manual and automatic operations are described. Operator controls and displays, including the solid state liquid crystal display (LCD) screen, are illustrated and explained for the UPS Module.

Section 4 - MAINTENANCE lists routine maintenance checks and helps the Operator pinpoint and quickly resolve problems if they arise.

If you require assistance for any reason, call Emerson Network Power® Liebert Services at 1-800-LIEBERT. For best service, please have the following information available:

Part Numbers: _____

Serial Numbers: _____

kVA Rating: _____

Date Purchased: _____

Date Installed: _____

Location: _____

Input Voltage: _____

Output Voltage: _____

Battery Reserve Time: _____

DISCONTINUED
PRODUCT

1.0 INTRODUCTION

1.1 System Description

The role of the UPS system is to supply uninterruptible, clean power to the critical load. It maintains a full-voltage, low-distortion output, even if the utility source power sags or becomes distorted.

If there is an outage of the source power, the UPS maintains power to the load until an alternate source of power is activated, or until the original power source is restored. If input AC power is not restored, the UPS maintains the load (with the battery plant) long enough that the critical equipment can be shut down in an orderly manner. The Liebert® Npower™ UPS module displays the rate of battery discharge and calculates the amount of battery time remaining based on the actual connected load. The time that the battery will maintain the load depends on the capacity of the battery backup plant and the size of the load.

The system control logic automatically manages critical bus operation. ActiveStar Controls are resident in Digital Signal Processors (DSPs) for precise control and improved reliability.

If the critical load current exceeds the rated load of the Liebert Npower UPS system, the control logic determines the magnitude of the overload and reacts appropriately. Overloads are usually the result of inrush current requirements. The UPS system supports loads that are 150% of the rated load for up to 60 seconds, 125% of the rated load for up to ten minutes, and 104% of the rated load indefinitely.

If the load surpasses the overload capacity of the UPS, the load is automatically transferred to bypass without interruption. When the load returns to within the UPS rating, it is either automatically or manually returned (retransferred) to the UPS. How and when the load is returned to the UPS depends on several factors: how long the overload lasted, how many overload conditions occurred before transfer, whether there is an imminent failure of any part of the UPS, etc. In the unlikely event of a fault within the UPS, the control logic, which continuously monitors all critical circuits within the UPS system, transfers the load to bypass without interruption and simultaneously sets off local and remote alarms. For a few specified faults, the UPS is shut down. The UPS can be manually returned to service when the fault has been corrected.

The Liebert Npower UPS display system provides precise monitoring of the UPS, fast alarm response, and quick troubleshooting. For easy manual operations, menu-driven software provides access to several step-by-step help screens. All operator functions are performed using menu-prompted displays and a minimum number of operator controls. Available options include external communication capability with both automatic dial-out and dial-in features for early warning and diagnosis of abnormal conditions.

The system software allows the operator or Liebert Services to enter application specific information. Overload, overvoltage, battery discharge, and shutdown limits can be set by the operator. In effect, the software is tailored for each site.

The UPS system protects critical equipment from source power disturbances and outages, load faults, and UPS malfunctions. This triple protection virtually eliminates computer and computing equipment downtime as a result of utility source power problems.

1.1.1 Reliability

Reliability is the most important design goal for Uninterruptible Power Systems. All Liebert® 3-phase UPS systems have demonstrated reliability by achieving a field-proven critical bus MTBF in excess of one million hours. In addition, our Quality Assurance program is certified to the requirements of ISO 9001 standards.

Liebert UPS systems are ETL listed to the requirements of UL 1778, CSA Certified and (when applicable) CE marked. All equipment and components are manufactured to applicable UL, NEC, IEC, EN, NEMA, ANSI, IEEE, EN50091-1, EN50091-2 and CSA standards and guidelines.

Designed For Success

The keys to reliability in the design of the UPS system are using conservatively rated components, minimizing transfers to bypass, making operator controls understandable, and providing easy access for maintenance and repair. Liebert UPS systems lead the industry in all these areas.

For example, the Liebert Npower™ can clear substantial overloads through the solid state static bypass switch without transferring to the bypass source. By minimizing transfers to bypass, the Liebert Npower minimizes operation of electrical components and enhances system reliability.

As mentioned above, the system control logic has been packaged into Digital Signal Processors (DSPs) to optimize system performance and eliminate the failure-prone discrete logic boards used in other brands of UPS products. Furthermore, these DSPs are isolated from heat-generating components to ensure optimal operating temperatures.

Factory Backup and Service Assistance

Reliability depends on more than just UPS module design. Improper installation can cause any system to fail. To prevent this, service technicians from Liebert Services thoroughly inspect the installation of all our systems to ensure they are installed properly and operating within performance specifications.

Once a UPS is properly installed, you -- the on-site equipment operator -- are the most important factor in preventing critical bus failures or unplanned transfers to bypass. To make your task easier, the UPS provides easy-to-follow, prompted instructions on its operator display screen.

If you ever need help, call your Emerson distributor or sales representative. Your attention to proper installation, operation, and periodic maintenance will ensure that your mission-critical operations receive the best possible protection from electrical disturbances and outages.

1.1.2 Versatility

The Liebert Npower has a number of features and options that can be customized to your specific needs. See **1.5 - Options** for details. Visit the battery manufacturer's Web site for information on obtaining the manual if you don't already have it.

1.2 Safety Precautions

Read this manual thoroughly, paying special attention to the sections that apply to you, before working with the UPS. Also read the battery manufacturer's manual before working on or near the battery.

Under typical operation and with all UPS doors closed, only normal safety precautions are necessary. The area around the UPS system and battery should be kept free from puddles of water, excess moisture, or debris.

Special safety precautions are required for procedures involving handling, installation, and maintenance of the UPS system or the battery. Observe precautions in the separate Installation Manual before handling or installing the UPS system. Observe precautions in **4.0 - Maintenance** of this manual before and during performance of all maintenance on the UPS or battery.

This equipment contains several circuits that are energized with high voltage. This is particularly true for oscilloscopes. Always check with an AC and DC voltmeter to ensure safety before making contact or using tools. Even when the power is turned Off, dangerously high potentials may exist at the capacitor banks. Observe all battery precautions when near the battery for any reason.

ONLY qualified service personnel should perform maintenance on the UPS system. When performing maintenance with any part of the equipment under power, service personnel and test equipment should be standing on rubber mats. The service personnel should wear insulating shoes for isolation from direct contact with the floor (earth ground).

Unless all power is removed from the equipment, one person should never work alone. A second person should be standing by to assist and summon help in case an accident should occur. This is particularly true when work is performed on the battery.

Three types of messages are used throughout the manual to stress important text. Carefully read the text below each Warning, Caution, and Note and use professional skills and prudent care when performing the actions described by that text.

A Warning signals the presence of a possible serious, life-threatening condition. For example:



WARNING

Lethal voltages may be present within this unit even when it is apparently not operating. Observe all cautions and warnings in this manual. Failure to do so could result in serious injury or death. Do not work on or operate this equipment unless you are fully qualified to do so! Never work alone.

A Caution indicates a condition that could seriously damage equipment and possibly injure personnel. For example:



CAUTION

Make sure you understand the proper sequence before operating any circuit breaker. Operating a Maintenance Bypass circuit breaker out of sequence could cut off power to the critical load.

A Note emphasizes important text. If the note is not followed, equipment could be damaged or may not operate properly. For example:



NOTE

If the UPS system has a blown fuse, the cause should be determined before you replace the fuse. Contact Liebert Services.

1.3 Modes Of Operation

Refer to **2.0 - Theory of Operation** and **3.0 - Operation** for more details.

1.3.1 Normal (Load On UPS)

The utility AC source provides power to the rectifier/charger in the UPS module. The rectifier/charger converts the utility AC power to DC and supplies DC power to the UPS module inverter while simultaneously float charging the battery plant. The UPS inverter converts DC to AC and furnishes AC power to the critical bus.

1.3.2 Input Power Failure

If the utility source power fails or is outside the acceptable range, the battery plant becomes the primary supplier of DC power to the inverter.

1.3.3 Recharge

After the utility source power is restored, or an alternate power source becomes available, the rectifier/charger slowly walks-in to once again power the inverters and recharge the battery plant.

1.3.4 Overload

Overloads in critical systems may be caused by inrush currents during connected equipment startup or by faults in the critical load or distribution network. The Liebert® Npower™ UPS system can maintain full output voltage regulation while sustaining the following overloads:

- Up to 125% for 10 minutes
- Up to 150% for 1 minute
- Up to 200% for 10 cycles

For momentary faults above 200% of rated current, the static switch turns on for 10 cycles to supply power from the bypass source. Up to 6,000 amps of current can be supplied for the first half cycle.

The critical load remains on the UPS module for the above conditions. If the UPS system overload capacity is exceeded, an automatic transfer to bypass is initiated, which keeps the static switch on and opens the inverter output contactor.

Whenever you have an overload condition, you should determine the cause of the overload.

1.3.5 Bypass (Internal)

The UPS control logic initiates an automatic transfer to the bypass source if the overload-current-versus-time curve is exceeded or if specified UPS system faults occur. You can also manually transfer the load to the bypass (without interruption) if you must take the UPS module out of service for maintenance.

With the rotary switch in the Bypass position, most key components and operating modes can be checked without disturbing the critical bus. However, certain key power-carrying components will require complete system shutdown or isolation through an external maintenance bypass cabinet for 100% service.

1.3.6 External Maintenance Bypass

The installation of an External Maintenance Bypass Cabinet or panel board is recommended to allow you to totally isolate the UPS from all power sources. Use of the External Maintenance Bypass is described in **SIB External Maintenance Bypass on page 30**.

1.3.7 Off-Battery

The battery plant can be disconnected from the rectifier/charger by using an external Module Battery Disconnect (MBD) circuit breaker. The UPS continues to function normally, though it does not have power outage back-up capability until the battery plant is reconnected.

Figure 1 UPS controls and display screen (with example of the monitor/mimic screen)

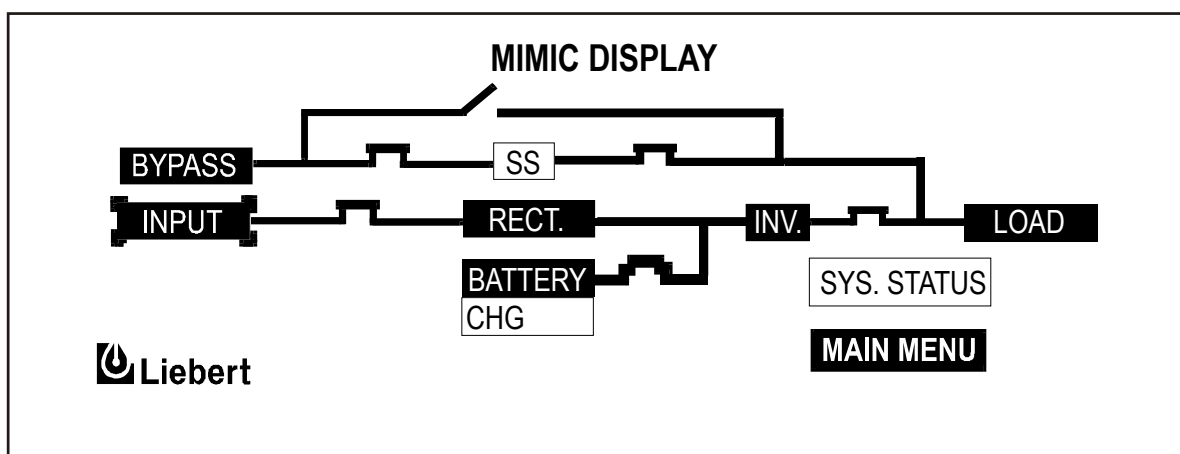

1.4 Operator Controls

Liebert® Npower™ UPS modules are equipped with a microprocessor-based Operator Display Screen and Control Panel designed for convenient and reliable operation. The front panel location of the monitoring and control system enables the Operator to quickly identify the current status of the UPS and to perform most of the manual operations.

The operator display screen is driven by an easy-to-follow menu-prompted software program that controls and monitors the UPS system.

Detailed instructions on how to interpret the displays and use the controls are in **3.0 - Operation**.

1.5 Options

A number of standard pre-designed options are available from Liebert for your UPS system.

Described below are the most frequently provided options. Note that the battery items (1 and 2) are required to complete the UPS system. The remaining options provide improved system performance or convenience.

1. **Battery and Racks.** The batteries provide power in the event of a power outage. The Liebert UPS can use a variety of battery types, provided the battery plant is designed for the UPS DC voltage range and the load requirements of your application.
2. **Module Battery Disconnect.** The UPS system utilizes a separate Module Battery Disconnect for remotely located batteries. A sensing circuit in the UPS module, set at the battery low voltage limit, trips the Module Battery Disconnect to safeguard the battery from excessive discharge. The Module Battery Disconnect has an undervoltage release mechanism designed to ensure that during any shutdown or failure mode all battery potential is removed from the UPS system.
3. **Input Distortion Filter (Trap).** This filter reduces input current reflected harmonic distortion to less than 10% THD at full load. The filter is factory installed within the UPS. This filter also improves the input power factor to better than 0.95 lagging.
4. **Load Bus Synchronization (LBS).** The Load Bus Sync (LBS) option keeps two independent UPS modules (and therefore their critical load buses) in sync, even when the modules are operating on batteries or asynchronous AC sources. This means that critical loads connected to both load buses can switch seamlessly between the two.
5. **Liebert SiteScan Central Monitoring System.** Liebert manufactures a central monitoring system that automatically displays key UPS measurements and alarms, as well as data from a variety of sensors. This monitoring system signals alarms so corrective action can be taken. Events and data can be printed in hard copy. Data can be logged for analysis. The SiteScan Interface port is standard for the Liebert Npower.
6. **Remote Alarm Status Panel.** The UPS system may also be provided with an optional Remote Alarm Status Panel. This Panel provides eight LED indicators and may be placed at a convenient location near the critical load. A functional description of the Remote Alarm Status Panel is provided in **3.5.3 - Remote Alarm Status Panel**.
7. **Open Comms - Discrete Output Option OC-DO (Programmable Relay Board).** Each option has 8 channels. Up to two Programmable Relay options can be installed in the same UPS. Any alarm/event can be programmed onto any channel or channels. Programming is performed through the LCD display. Each relay channel has two sets of Form-C dry contacts rated 1 Amp @ 30 VDC or 250 mAmp @ 125 VAC.
8. **Open Comms - Discrete Input Option OC-DI (Input Contact Isolator).** Provides UPS module interface for up to eight user relay inputs (normally open dry contacts) for user alarm messages. The user through the LCD display can program the UPS alarm messages. The input alarm can also be installed to trigger an Open Comms - Discrete Output Option channel. Each alarm can have auto-dial, event log, and time delay (0 to 999.9 seconds).
9. **Optional Power Supply (OPS).** An additional control power supply is required when a Remote Alarm Status Panel and/or three or more battery circuit breakers are present in the system.
10. **Internal Modem.** Provides a 2400-baud modem in the UPS capable of dialing out from the UPS or accepting incoming calls and connecting to a remote terminal, computer or PC. A command set allows the user to view the alarm status, event log status, history status and system settings. The modem can also be configured to dial out two different telephone numbers, a primary and a backup number as a result of a significant UPS event. The selection of dial-out events is programmable by the Operator.
11. **Network Interface Card - NIC.** This option provides internal hardware and software to communicate (via SNMP and HTTP) to any I.P.-based Ethernet network. Connection to the network is made by a 10 baseT Ethernet cable provided by the user.

2.0 THEORY OF OPERATION

2.1 General Component Description

The UPS system includes all of the equipment necessary to continuously provide computer-grade AC power to a critical load, even when there is an interruption of the utility line power. It consists of the UPS modules and a back-up battery plant. Refer to **Figure 2**.

2.1.1 UPS Module

The UPS module consists of system controls, a rectifier/charger, an inverter, protective devices, and other accessories.

System Controls: The system control logic automatically manages critical bus operation and monitors performance of the UPS module. Microprocessor technology and dedicated firmware provide advanced logic control and a comprehensive display of information. The UPS module status is displayed locally. Optional ports permit communicating with external devices.

Rectifier/Charger: The rectifier/charger converts utility power from AC to DC to charge the battery and provide the DC input to the inverter. Its design limits reflected harmonic current distortion to source power and provides low-ripple DC power for charging batteries.

Inverter: The inverter converts DC power into the precise AC power required to supply a sensitive critical load. The inverter converts DC power into a pulse-width-modulated (PWM) that is easily filtered into a clean sine wave output. The PWM also minimizes the harmonic voltage distortion caused by typical switching power supplies and other nonlinear load components used in computers and related electronics.

Static Bypass Switch: The static (solid-state) bypass switch immediately transfers the load from the inverter to the bypass AC power source in the event of a severe overload on the system or a failure within the UPS. This transfer takes place without any interruption of the power supplied to the load. The system includes redundant circuits to detect and isolate shorted SCRs in the static switch.

Bypass Circuit: The bypass circuit consists of switches and associated synchronizing and control circuitry to transfer the load to/from the bypass source.

2.1.2 Battery System

The battery is used as the alternate source of power to supply DC power to the inverter if the AC supply voltage is outside the acceptable range. The battery supplies power to the inverter until the utility power is restored or until an alternate power source is available. If AC source power is not restored or an alternate power source is not available, the battery can be sized to provide power long enough for an orderly shutdown of the load.

2.2 Detailed Component Descriptions

2.2.1 Controls

Hardware

The Liebert® Npower™ UPS operator interface display system is designed to provide all of the information that is required for the operation of each UPS module. The following is a list of the hardware features:

1. The control logic performs automatic operations with minimal operator interface. The limited number of manual controls are easy-to-use.
2. Each Liebert Npower UPS cabinet is equipped with an easy-to-read liquid crystal display (LCD) screen. It presents information in a way that is easy to understand at an eye-level front panel location.
3. The display is controlled by a dedicated microprocessor with a non-volatile (EPROM) program and a battery-backed event memory.
4. The Liebert Npower can be ordered with communication ports for:
 - a. Transmission of present status information to remote terminals via a resident auto-dial communications program and an external or optional internal modem. This port also responds to inquiries of the UPS and history from the remote terminal.
 - b. Reporting UPS and history information in response to inquiries from a local terminal (no modem required).
 - c. Reporting information to a Liebert SiteScan® Central Monitoring System.
 - d. Relaying selected alarm messages to a Liebert Remote Alarm Status Panel and to a separate terminal board for customer use.
 - e. Reporting key systems information via SNMP interface to a network monitoring system.



NOTE

All external communication devices are optional equipment.

Firmware

The operator interface display system software enables the operator to monitor the UPS system status, to control the power flow through the UPS, to monitor all of the meter readings, to execute the start-up, shutdown, and the load transfer procedures, to access the event history files, and to make adjustments to the programmable parameters. The following is a list of the firmware features:

1. The menu-driven software prompts the operator for input.
2. Step-by-step instructions assist the operator during the start-up, shutdown, and the load transfer procedures. This helps to eliminate operator errors.
3. Graphics-based mimic diagrams illustrate the position of internal switches and the power flow through the UPS system.
4. The Present Status screen reports information about the system's present status. The History Status screen chronicles the events leading up to and immediately after a fault. The Event History screen lists all of the alarm messages that have been logged over a period of time.

Refer to **3.0 - Operation** for a description of the controls and indicators located on the Operator Control Panel.

2.2.2 Rectifier/Charger

The UPS module rectifier/charger consists of input fuses, AC current-limiting circuit, battery equalize charge circuit, DC filter, battery charge-current-limiting circuit, and bridge rectifiers.

Operation

The rectifier/charger converts the AC input power to DC power. This conversion is accomplished by 3-phase bridge rectifiers using SCRs. All phases are individually fused. For all modules, reflected input current THD is less than 30% at full load (which may be reduced to less than 10% with optional filter).

The filtered output of the rectifier/charger provides regulated DC power to drive the inverter and charge the battery.

Input

The input is sized to allow enough current to recharge the battery and supply a full-rated load at the same time.

Input Current Limit

AC input current sensing transformers (CTs) are used to measure current levels. Control circuitry monitors the CTs and restricts the AC current to less than 125% of the full input current rating by reducing the battery charging voltage. This current limit is adjustable from 100 to 125% of the system capacity measured in AMPS, with the default setting at 125% (maximum AMPS). An external dry contact closure (field supplied) activates a reduced second level of the battery charge current limiting circuit for use with a back-up generator.

Input Current Limit, Second Level

A second level of input current limit is initiated by an external contact closure (field supplied for use with back-up generator), and is adjustable from 85 to 100% (factory set at 100%).

During a rectifier re-start following battery discharge, the current slowly ramps up (walks-in) from 20% of the rated input current to 100% over a 15 to 20 second period. The maximum rate of change of the AC input current is 15% per second. The input current walk-in reduces the start-up surge distortion effects on all other equipment connected to the same source and prolongs the service life of internal components.

Input Current Inrush

The maximum sub-cycle of inrush current is typically less than 6-8 times normal.

Input Power Factor

The rated input power factor is no less than 0.80 lagging at the nominal input voltage and the full rated UPS load. The optional input filter will improve the power factor to better than 0.92 lagging at full load. Refer to drawings for your specific model.

2.2.3 Battery Charging Circuit

The UPS module charging circuit is capable of recharging the battery plant to 95% of full capacity within 10 times the discharge time. Recharging the last 5% takes longer because of characteristics inherent in the battery. DC ripple voltage is limited to 0.5% RMS to preserve battery life during long-term float charging while the UPS system is operating on utility source power.

Operation After Discharge

When commercial power is interrupted, the battery continues to supply DC power to the inverter without interruption to the critical load. If the AC source power is restored before the battery has fully discharged, the rectifier automatically restarts and resumes carrying the inverter and battery recharge load requirements.

Operation After End-of-discharge

The battery time screen displayed on the control panel enables you to estimate when battery shutdown will occur. You will have enough time to energize an alternate AC power source or to initiate an orderly shutdown of the critical load. If the battery plant discharges to the shutdown point during an outage, the UPS automatically disconnects the load, the AC input, and the battery. After AC input power is restored, the rectifier can be manually restarted by the Operator.

Battery Disconnect

The module battery disconnect (MBD) circuit breaker is used to isolate the UPS module from the battery during maintenance, and to automatically disconnect the battery from the inverter at the end of battery discharge. The MBD circuit breaker must be closed manually unless you have the optional motorized battery breaker. (See **3.3.8 - Auto Restart**).

Battery Charge Current Limiting

The battery recharge current, after a battery discharge, is limited to between 1 and 25% (adjustable) of the full load maximum discharge current stated in AMPS. This regulates the amount of current that flows from the power source to the battery while the battery is recharging.

The battery charge current limit is factory set at one-half of maximum or 12.5% for normal operation and at 1% for alternate power source recharge operation.

Battery Equalize Charge Circuit

The battery equalize charge feature can be manually initiated or it can be programmed to operate automatically. Either can be selected from the battery equalize screen displayed on the control panel.

The automatic battery equalizing charge circuit increases the rectifier/charger output voltage to charge the battery anytime there is a power outage of 30 seconds or longer. The equalizing voltage is slightly higher than the float voltage. This helps all the batteries in a string to reach a uniform state of charge.



NOTE

The manufacturers of the valve-regulated batteries supplied with Liebert's standard battery cabinets recommend that when first installed the batteries be equalize charged. After that initial equalize charge, they recommend no further equalize charging for their batteries. Other manufacturers may have different recommendations for their products. Consult the battery manufacturer's manual for specific information about equalize charging.

2.2.4 Inverter

The inverter is a solid state device that converts the DC output of the rectifier/charger or the battery to AC power.

Operation

The inverter converts DC power from either the battery or the rectifier/charger into three pulse-width-modulated/six-step waveforms. These waveforms are filtered into low-distortion sine wave power. The inverter is controlled by a Digital Signal Processor (DSP). This DSP controls the precise synchronization, amplitude, and frequency of the output voltage.

In addition to the inverter efficiently supplying a regulated AC output from a DC source, the inverter output provides isolation between the critical load bus and the commercial source power. The inverter is configured to handle most critical load inrush surges. It maintains output voltage Total Harmonic Distortion (THD) within specifications even when handling nonlinear computer loads.

Output Regulation and Overload Performance

The inverter is capable of sustaining full output voltage ($\pm 1\%$ of the nominal voltage) for up to 150% overload at the output for as long as 60 seconds without reducing the output voltage. It can also handle at least 125% of the rated current for up to 10 minutes. If an overload exceeds the system capacity and a bypass source is available, the critical load is transferred to the bypass source and the inverter is disconnected from the load.

Nonlinear Load Characteristics

Computers and computer equipment with switching power supplies generate nonlinear currents rich in fifth and seventh harmonics.

The inverter pulse-width-modulated waveform, coupled with the output filter, provides a natural path for reducing the fifth and seventh harmonic currents produced by the load. The inverter/filter limits the output voltage THD to less than 3% with up to 100% typical electronic data processing (EDP) loads. EDP equipment characteristically includes both nonlinear and linear load components.

Unbalanced Load Characteristics

Unbalanced loads are actively regulated. The phase-to-phase voltage balance is maintained to within 2%, even with a 50% load imbalance.

2.2.5 Static Bypass Switch

A static bypass switch is an integral part of the UPS. An automatic transfer control circuit senses the status of the operator controls, UPS logic signals and alarm messages, and critical bus operating conditions. If the inverter output can no longer supply the critical load, the static bypass switch automatically transfers the critical load to the bypass source without interruption.

Static Switch Backfeed Protection

The static bypass system is equipped with redundant disconnect circuits that prevent backfeed of lethal voltage to the bypass input in the event of a shorted static switch SCR. If a shorted SCR is detected, the static bypass switch is isolated and an alarm is annunciated at the UPS control panel, while the critical load remains on UPS output power.

Pulsed Parallel Operation

When an overload condition such as magnetic inrush current or a branch load circuit fault exceeds 200% of the full-load current rating, the static bypass switch pulses on for 10 cycles. This allows up to 6000 amperes from the bypass line to clear the overload without a complete transfer to bypass (an Emerson design exclusive). The bypass source is in parallel with the UPS system, permitting the bypass source to carry the initial overload current. If the overload clears before 10 cycles, a load transfer to bypass is not made. If the overload condition continues to exceed the inverter capacity, the automatic transfer is made (maintaining the load voltage within the specified limits).

Load Transfers

Transfers to (transfer) or from (retransfer) the bypass may be performed automatically or manually in a make-before-break (MBB) sequence.

Manual load transfers and retransfers are initiated by the Operator from the UPS Control Panel.

Automatic transfers are initiated by the UPS system control logic when an overload is beyond the specified capabilities of the UPS inverter or when a fault occurs within the UPS module. An automatic retransfer is initiated if this function is enabled and if system conditions for a retransfer are present.

Transfer and Retransfer Conditions

1. Automatic Transfers to Bypass:

Critical bus conditions that will initiate an automatic transfer of the critical load from the UPS inverter output to the bypass source are:

 - a. Output Overload: overcurrent condition in excess of the current-versus-time overload capacity curve.
 - b. Over/Under Voltage (OV/UV): critical bus voltage is outside the allowable tolerance.
 - c. Inverter Inoperative: inverter diagnostic circuitry senses an imminent inverter output OV/UV condition:
 - d. Battery discharged to the shutdown voltage.
 - e. Inverter or rectifier fault condition (power, logic, or over-temperature) present or imminent.
 - f. Failure of system logic or logic power.
2. Manual Transfers:

Manual transfers may be initiated at any time provided no transfer inhibition conditions are present.
3. Transfer Inhibited:

A manual transfer to the bypass source will be inhibited if any of the following conditions exist:

 - a. Bypass frequency deviates ± 0.5 Hz from the nominal.
 - b. UPS system to bypass voltage difference (DV) exceeds a predetermined percentage (normally 10%).
 - c. OK to Transfer signal from the control logic is not present.
4. Automatic Retransfers to UPS:

Critical bus conditions that must be present to initiate an automatic retransfer (Auto-Rexfer) of the critical load from the bypass source to the UPS system are:

 - a. The number of Auto-Rexfer Attempts selected must be greater than zero (0). If zero (0) is selected, no automatic retransfer will occur.
 - b. Critical load was initially transferred to the bypass source due to a system overload only.
 - c. Overload has since been eliminated (the load has dropped below 100% of the rated load).
 - d. Both the Input contactor and Battery (MBD) circuit breakers have remained closed since the overload transfer.
 - e. OK to Transfer signal received from the control logic for at least 10 seconds, within 5 minutes of the overload transfer. (A manually initiated retransfer from bypass is required for overloads lasting 5 minutes or more.)
 - f. Cyclic-type system overloads, which occur up to five (select range is 0 to 5) times in 60 minutes, are automatically returned to the UPS system for each event including the Nth overload. A manually initiated retransfer from bypass is required for the N+1 overload.
5. Manual Retransfers:

Manual retransfers may be initiated at any time provided no retransfer inhibition conditions are present.
6. Retransfer Inhibited:

A retransfer (automatic or manual) from the bypass source to the UPS system shall be inhibited if any of the following conditions exist:

 - a. Retransfer Inhibitions:
 1. Bypass frequency exceeds ± 0.5 Hz of the nominal.
 2. UPS system-to-bypass voltage difference (DV) exceeds a predetermined percentage (normally 10%).
 3. OK-to-Transfer signal from the control logic is not present.
 4. Inverter or rectifier fault.
 - b. Automatic Retransfer Inhibitions (in addition to those above):
 1. The load transfer to bypass was not caused by an output overload.
 2. Excessive cyclical overloads within a one-hour period.
 3. Retransfer conditions are not satisfied within 5 minutes of the initial transfer.

3.0 OPERATION

3.1 Operator Controls

The Liebert® Npower™ operator controls and indicators are located on the UPS Module Cabinet door and inside the cabinet. See **Figure 2**. The Operator Control Panel is located in the upper lefthand corner of the door, enabling the Operator to quickly identify the current status of the UPS system and to perform most of the manual operations. The operator display screen is driven by an easy-to-follow menu-prompted software program. The internal control system executes programs which generate messages on this display screen. Screen messages instruct the Operator during start up, operation, and shutdown. The screen also displays status information upon request. Operating the UPS consists of watching the indicators on the operator control panel and making appropriate responses. Further UPS monitoring and testing is achieved by navigating through a series of menu selections on the display screen.

Figure 2 80 kVA UPS outside and inside views

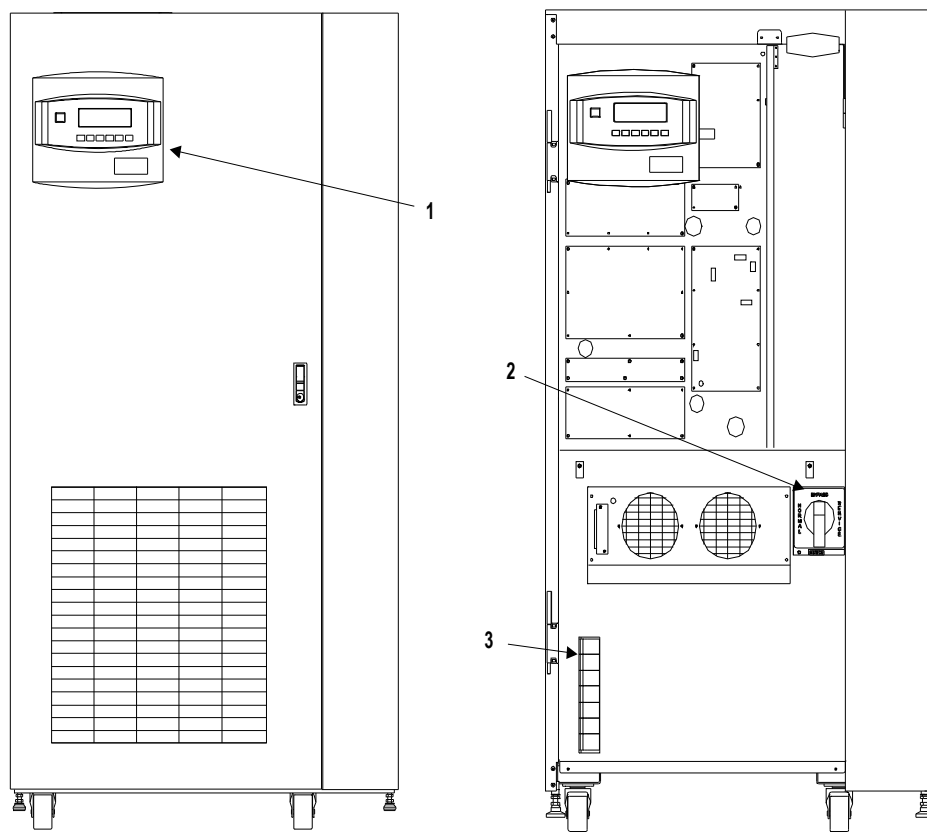

Table 1 Key locations on UPS

Item	Description	Function
1	Operator Control Panel	Contains Display screen, Navigation buttons and Emergency Power OFF button.
2	Rotary Switch	Provides manual selection of Normal, Bypass and Service modes.
3	Fuse Blocks	Contain fuses for UPS control power.

DISCONTINUED PRODUCT

Figure 3 Operator control panel

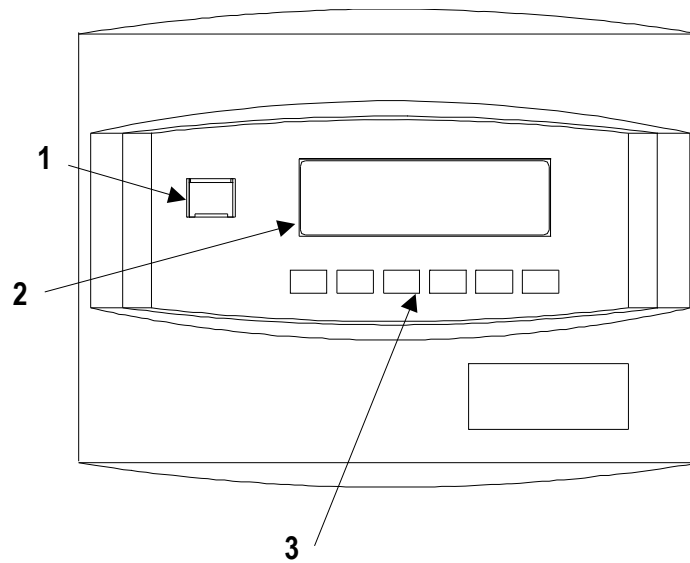

Table 2 Key locations on operator control panel

Item	Description	Function
1	Emergency Power Off Button	Turns power off in an emergency situation.
2	Display Screen	Enables Operator to monitor power flow and meter readings, receive reports, and execute operational procedures.
3	Navigation Buttons	Enables Operator to access menu screens and make selections.

3.1.1 Operator Control Panel

The Operator Control Panel enables the operator to perform the following tasks:

- Obtain a quick indication of operational status:
 - Is the critical bus OK?
 - Is the UPS system OK?
 - Is the battery available?
 - Is the bypass line available?
- Monitor the power flow through the UPS system and monitor all meter readings:
 - Is the critical load being supplied power from the UPS system or bypass?
 - Are input, battery, and output voltage, frequency, and current readings at nominal levels?
 - How much battery time is still available during an outage?
 - Is the battery recharging after discharge?
- Execute operational procedures:
 - Perform critical bus transfer/retransfer between the UPS and the bypass line.
 - Start-up and shutdown the UPS.
 - Shutdown the system instantly in the event of an emergency.
- Access status reports and history files:
 - Obtain a complete listing of the present status of the UPS including input, output, and battery voltage, frequency, and current readings, and any alarms that may be present.
 - Review a complete history report of all events leading up to and immediately after a fault condition.
 - Examine an archive listing of all alarm conditions that have occurred over a period of time.
- Make adjustments to programmable parameters (access limited by Security Access function):
 - Set the date and the time functions.
 - Change the auto-dial phone number and the modem options.
 - Select the number of auto-retransfer attempts.
- Make adjustments to the UPS output voltage before performing a manual load transfer.

3.1.2 Navigation Buttons

The Navigation Buttons are located below the Display Screen.

Figure 4 Navigation buttons

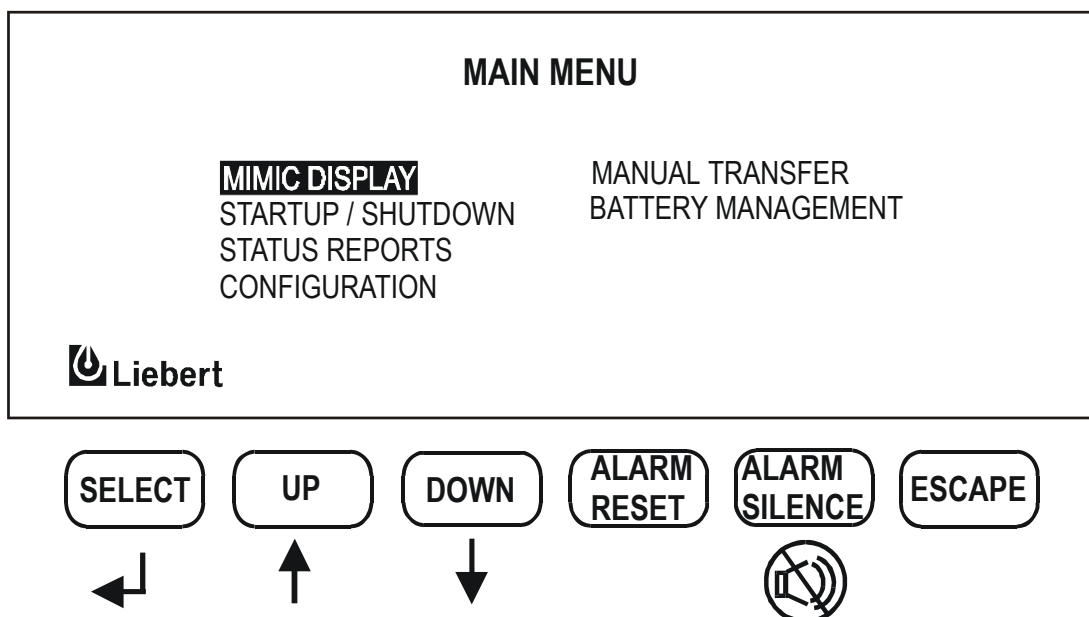

The SELECT button is used to select a particular item from the options on the screen. When you press this button, the screen that is selected will be immediately displayed.

The UP and DOWN buttons are used to move the cursor around the screen in order to highlight appropriate selections.

The ALARM SILENCE button silences the audible alarm and discontinues the flashing of the alarm messages.

The ALARM RESET button clears a latching alarm after the alarm condition is corrected.

The ESCAPE button is used to exit the screen and return to the Mimic Display.

3.1.3 Rotary Switch

The Rotary Switch is located on the lower right side of the panel inside the cabinet. This switch provides single-point control of the UPS.



NOTE

Improper positioning of the rotary switch can result in unwanted actions. Therefore it is important to read the complete instructions before using this switch, and to follow Operator prompts on the display screen.

Figure 5 Rotary switch

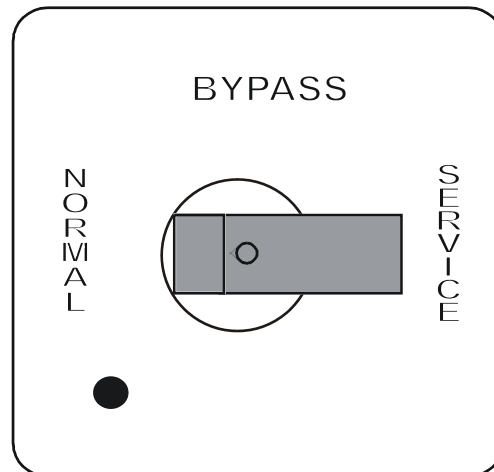

The Rotary Switch has 3 positions:

- **NORMAL:** The Normal switch position is used under most operational conditions.
- **BYPASS:** The Bypass switch position directs the power flow through the Internal Bypass Circuit. The UPS module may be either on or off. If the UPS module is on and the batteries require charging, charging will take place.
- **SERVICE:** The Service switch position directs the load to the Internal Bypass Circuit so the UPS can be serviced.



NOTE

For purposes of this manual, assume that the rotary switch will always be in the NORMAL position.



NOTE

If the position of the rotary switch must be changed, as in servicing, it is imperative that the Operator observe the light in the corner of the Rotary Switch panel before making any change. The switch position may be changed only if the light is green. Never move the switch if the light is red. Instead, call the Liebert® Services technician.



NOTE

The LED light is positioned in the lower left-hand corner.

3.2 Security Access and Passwords

Password protection is provided in the Liebert® Npower™ UPS system to protect you from any unauthorized configuration of the system. A default password is installed on your system when you receive it. The default password is NPWR. It is important, however, that you enter your own secure password as soon as possible. The following procedure will enable you to do this.

1. From the MAIN MENU on the Display Screen, navigate to the primary CONFIGURATION Screen. It will look like the figure below.

Figure 6 Configuration screen

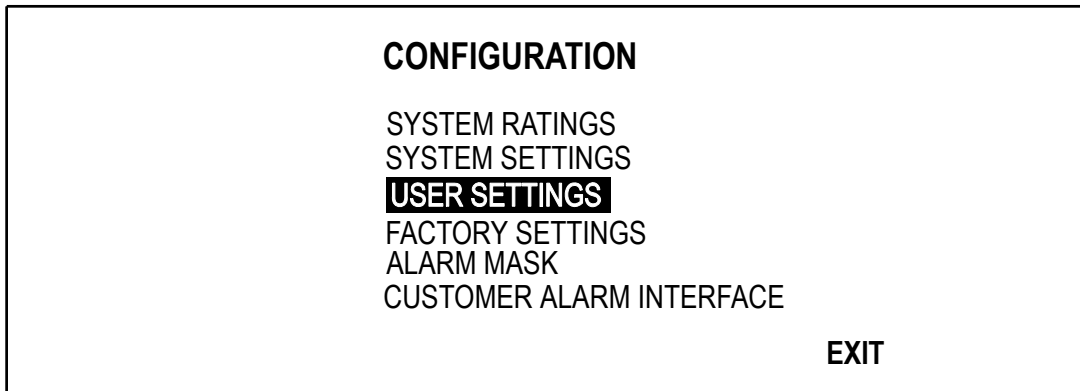

2. Highlight USER SETTINGS using arrow keys, and press SELECT.
3. The USER SETTINGS screen will come up.
4. Bracket NEXT using arrow keys and press SELECT five times. This will take you to the sixth page of the USER SETTINGS screen.

Figure 7 User settings screen, page 6

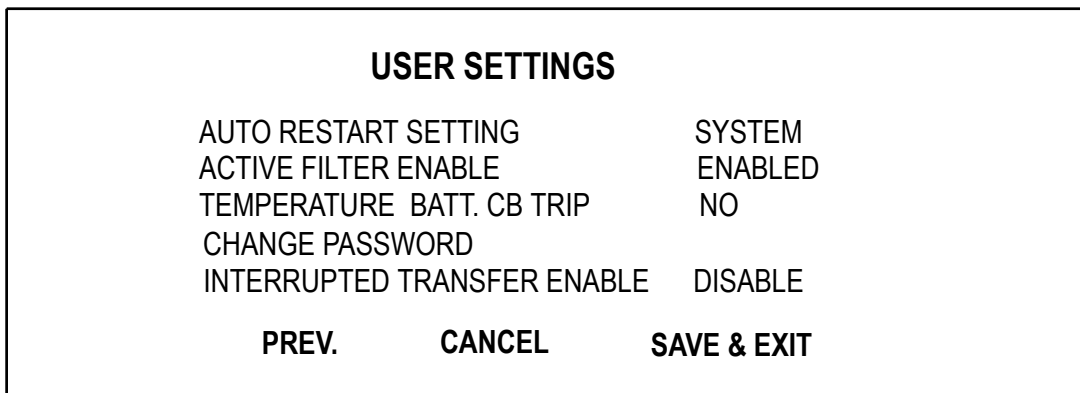

Highlight CHANGE PASSWORD. This action will bring up the PASSWORD screen. You must know the current password in order to change it. Next, you will be prompted to enter a new 4-digit password. The new password may contain letters from A through Z and/or digits from 1 through 9.

5. You now have 5 minutes to examine and configure password-protected screens.
6. After five minutes you must re-enter the password in order to unlock further password-protected screens.



NOTE

The TIME and DATE of all password changes are logged in the event log.

DISCONTINUED PRODUCT

3.3 Display Screens and Procedures

The Operator Interface Display System of the Liebert® Npower™ allows quick access to any screen the operator chooses. The default screen is the Mimic Display Screen.

MENU TREE

The figure below shows the primary screens that you can access through the Operator Interface Display System.

Figure 8 Menu tree

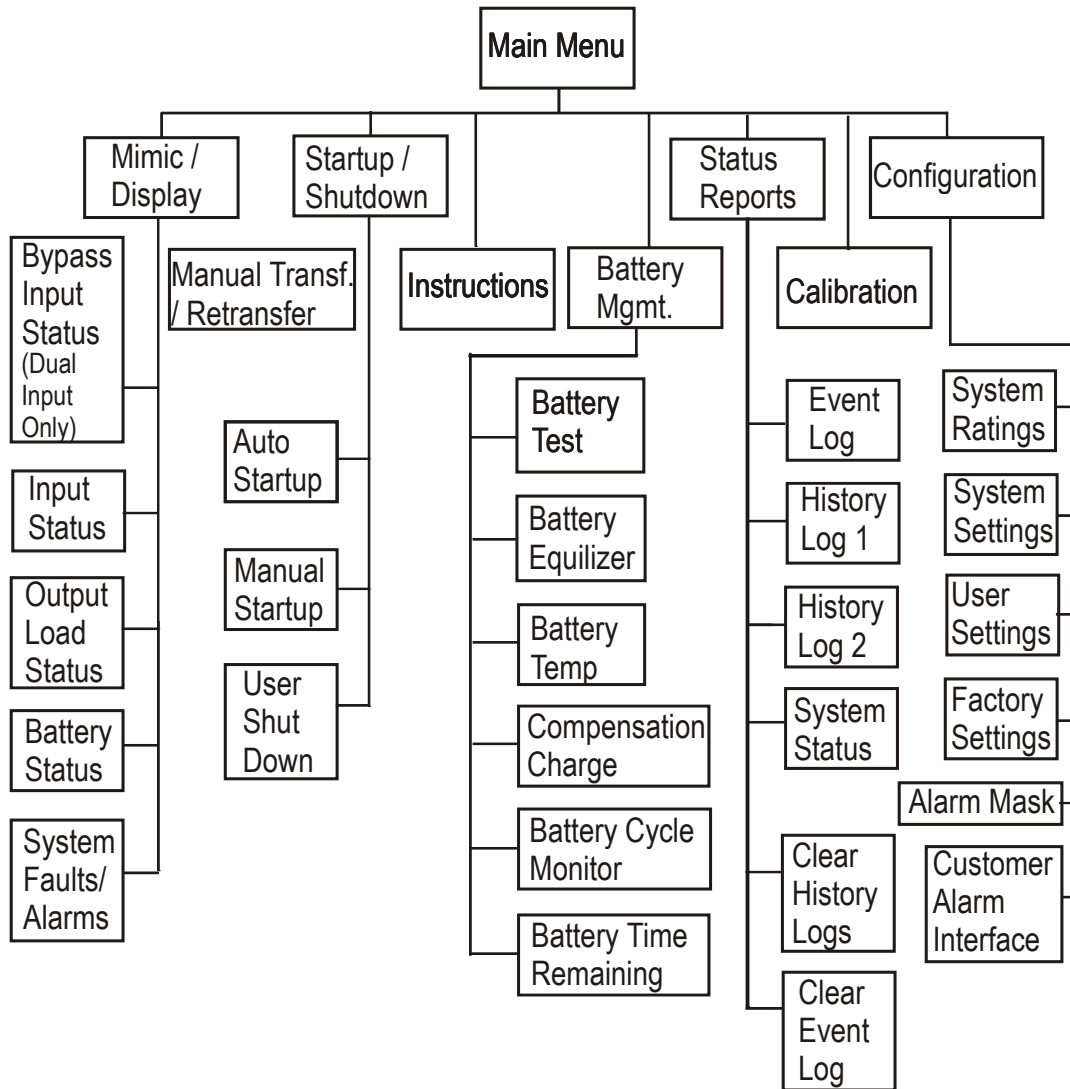

NOTE

Any screens where changes in configuring, settings or data can be made (including all the Configuration screens) are password-protected.

Primary Screens

The Main Menu has eight primary screens. Please note that some screens have multiple pages because not all the information can fit on one page. To access the next page, highlight NEXT and press SELECT. To access the previous page, highlight PREV and press SELECT.

- **Mimic Display.** This graphic portrays the power flow through the UPS. Switch indications, system status, and alarm messages are all displayed on this screen. Detail screens can display input voltage and current readings, battery status, and load characteristics and alarm info.
- **Status Reports.** This display consists of three sub-menu selections: present status, history log and event log. These screens display data on the system's present and past performance. They also display information about any faults that have occurred in the system. Total operating hours are displayed here.
- **Configuration.** This screen displays the current configuration of the UPS system. It also enables the operator to reset the date, time, dial-out phone numbers and System Options. System Options include Temperature-Compensated Charging, Customer Alarm Definitions and Battery Load Test. The operator can view, but can not change, any of the settings unless the password is entered. See **3.2 - Security Access and Passwords** for more information.
- **Manual Transfer.** This screen specifies all of the steps required to manually transfer the critical load between the UPS and the bypass source. Comparisons of the voltage, frequency, and phase synchronization of the UPS output and the bypass line are also illustrated to aid in the transfer or retransfer procedure.
- **Startup and Shutdown Procedures.** These screens list step-by-step procedures to start up UPS or to shut it down for maintenance or repairs. Screens include the following: Auto Startup, Manual Startup, and two types of Operator Shutdown procedures.
- **Battery Management.** These screens display information on battery self tests, battery equalization, and battery compensated charging. This enables the operator to immediately see the effects of load shedding on time remaining and to accurately assess his power resources. The battery equalize screen lets the operator change the battery equalize recharging mode from manual to automatic, and to observe or change the equalize time. Battery equalize charge voltage is higher than battery float (constant) charge voltage.



NOTE

The manufacturers of the valve-regulated batteries supplied with Liebert's standard battery cabinets recommend that when first installed the batteries be equalize charged. After that initial equalize charge, they recommend no further equalize charging for their batteries. Other manufacturers may have different recommendations for their products. Consult the battery manufacturer's manual for specific information about equalize charging.

Secondary Screens

The secondary screens show detailed information relating to the primary screens. These screens are illustrated below under each primary screen. Like the primary screens, the secondary screens may also consist of multiple pages. To get to the next page, highlight and Select the word NEXT. To return to the previous screen, highlight and Select the word PREV.

STATUS INFORMATION

Module status information is available on the display screen when the Control Power is ON, even when the UPS module is not operating. The same system status information is also available at local and remote terminals. See **3.3.4 - Status Reports** for information on status reports and **3.5 - Communication Interfaces** for information on Operator communication interfaces.

If a module display screen is blank, either power is not available, the Rectifier Input (RIB) circuit breaker (external to the UPS module) is open, or the Control Power is OFF. If power is available and a display is blank, contact Liebert® Services (1-800-Liebert, or 1-800-543-2378).

Main Menu Screen

The Main Menu contains the primary menu selections that monitor and control the operation of the UPS. To access one of these screens, use the NAVIGATIONAL BUTTONS beneath the screen.

First, press the UP or DOWN button until the desired screen is highlighted. Then press the SELECT button.

From any screen, pushing the Escape button once will return you to the Mimic Screen.

Figure 9 Main menu screen

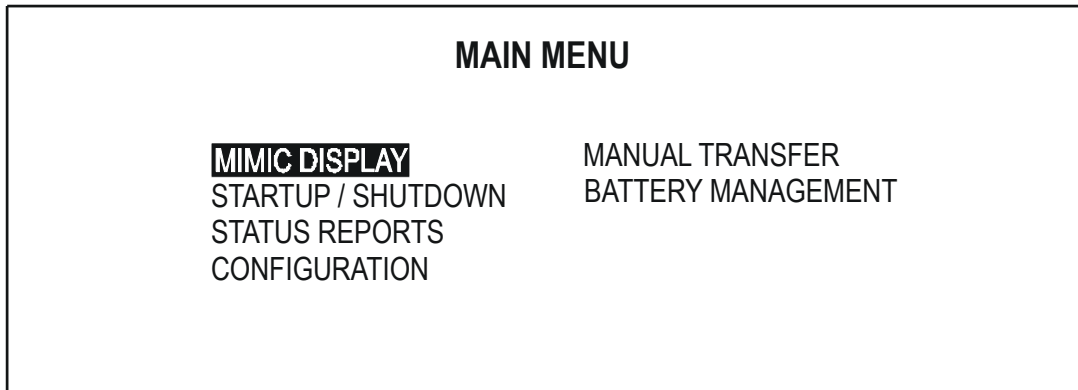

3.3.1 Mimic Display Screen

From Main Menu move the highlighted cursor to MIMIC DISPLAY and press the Select button. This brings up the Mimic Display Screen.

The Mimic Display screen is the default screen on the Operator Display. It is a simplified block diagram showing an overall view of the power flow through the UPS system. Solid lines indicate power flow; white lines with thin black edges indicate that power is not flowing in that area. The following examples illustrate power flow under different conditions.

Figure 10 Monitor / mimic display screen example: normal power flow

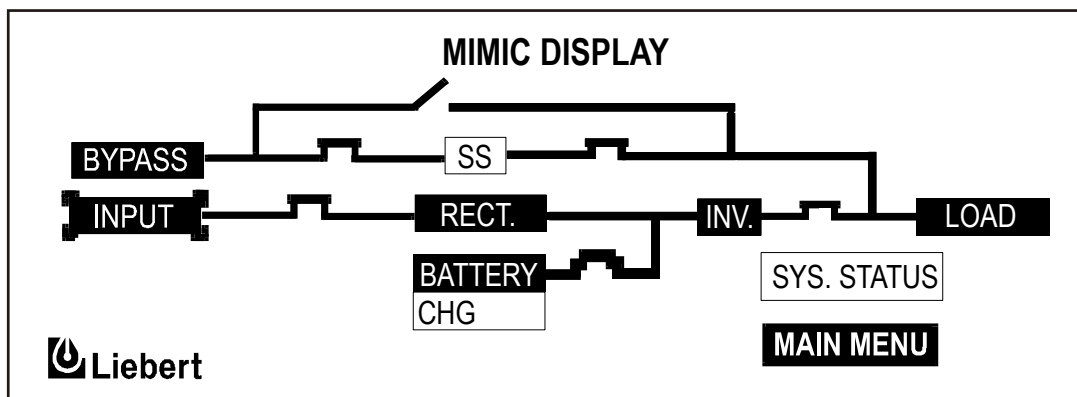

DISCONTINUED PRODUCT

In this example, power is available from the normal and bypass sources, as well as from the battery. Notice that the switching devices are all closed except for the bypass switch at the top. The load is operating on conditioned power from the inverter. The battery is being charged by the rectifier. The static switch is operative and ready to respond to momentary demands for overload current.

Figure 11 Mimic display screen example: utility fail

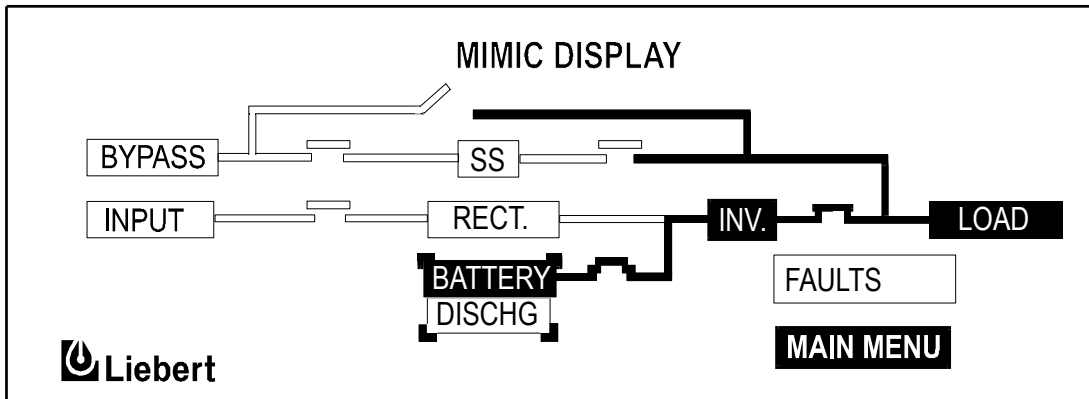

In this example, we see that a utility failure has shut down both the normal and bypass power sources. The battery is connected and supplying power to the load.

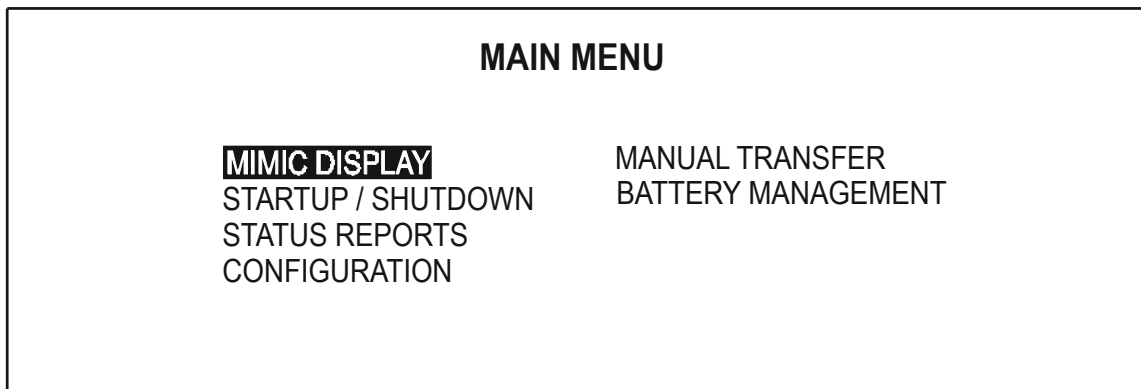
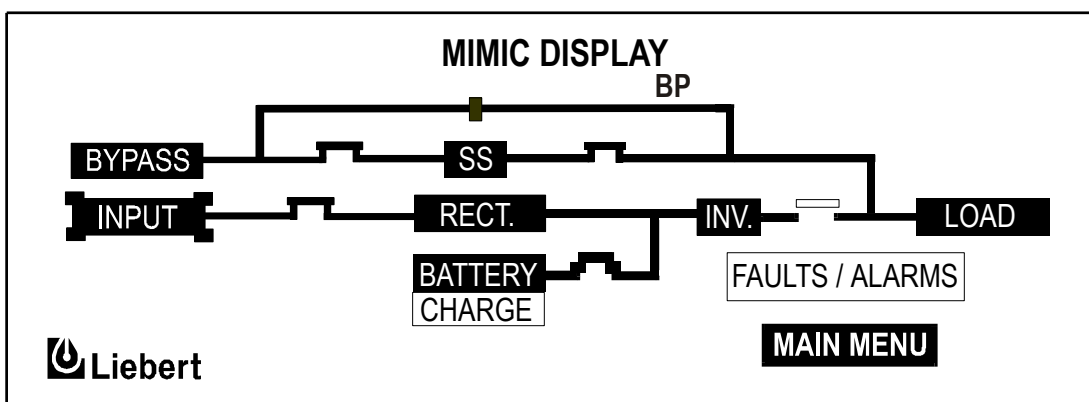

Figure 12 Mimic display screen example: load on bypass, UPS module on and charging battery



DISCONTINUED
PRODUCT

In this example, the load is receiving power through the bypass switch. Notice that the input power source is available and the battery is being charged.

Figure 13 Monitor / mimic display screen example: load on bypass, UPS module off, service mode

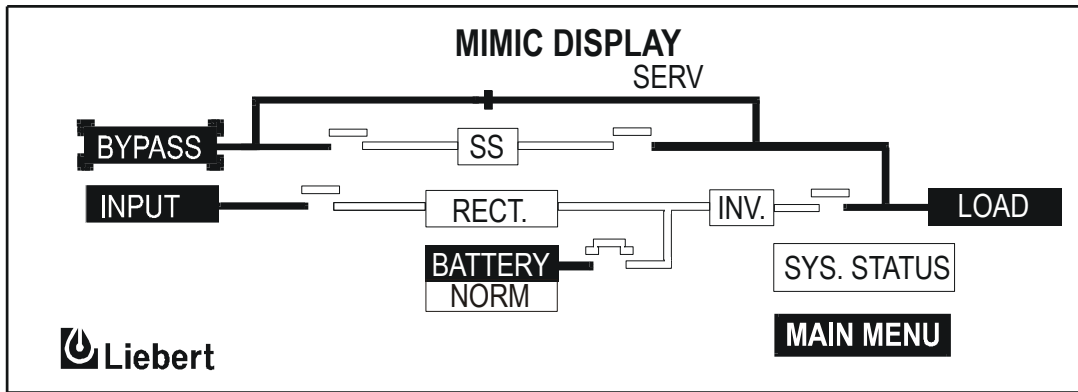

In this example, the power is coming from the bypass source through the bypass switch to the load. The UPS module is off, as shown by the open rectifier and inverter switches. Notice also that the battery circuit breaker is open.

THE MIMIC DISPLAY SCREEN

The illustration below shows the five major sections of the Mimic Display Screen. The numbers in the illustration correspond with the explanation below for each numbered block

Figure 14 Mimic display screen detail

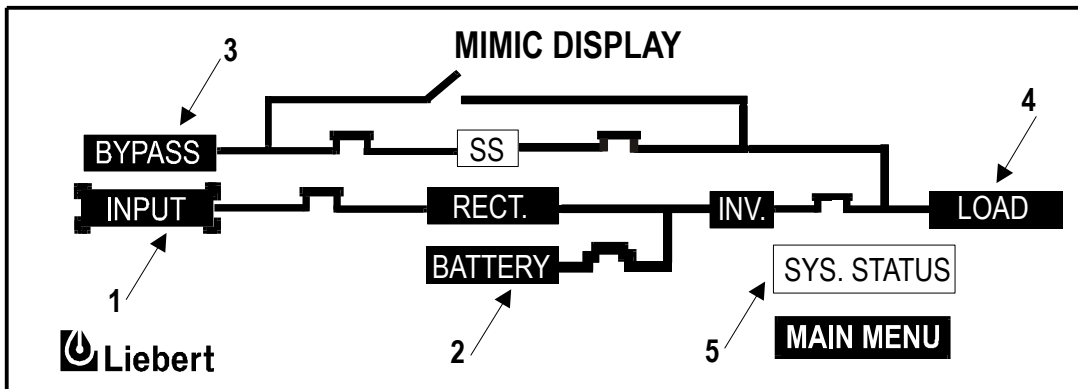

DISCONTINUED PRODUCT

Detailed Information Reports

Detailed information reports are available through the following numbered blocks

1. **INPUT STATUS.** To access this screen, start with the Mimic Display Screen. Using the arrow keys, bracket INPUT and press SELECT. The screen displays the UPS input voltage and current as well as additional information. Press SELECT to return to the Mimic Display Screen.



NOTE

On the Mimic Display Screen, items are bracketed instead of highlighted so as not to confuse highlighting with power pathways.

Figure 15 Input status screen

INPUT STATUS						
		A	B	C	FREQ. 60.0 HZ	
V	L - L	209	209	210	TEMPS (DEG C)	
I		37	37	35	INLET AIR 24	
					OUTLET AIR 27	
					HEAT SINKS	
					1:025 2:020 3:020	



NOTE

All voltage readings are phase-to-phase measurements (A-B, B-C, and C-A). All current readings are phase measurements (A, B, and C). The metered parameter values on the following screens are updated at one-second intervals

The Input Status screen displays the following real-time data:

- Input AC Volts AB, BC, CA
 - Input Current A, B, C
 - Input Frequency
 - Inlet Air Temperature
 - Outlet Air Temperature
 - Heat Sink Temperature (100 and 130 kVA will display 3 temperatures, 1 for each heatsink)
2. **DC BUS / BATTERY.** By highlighting and selecting BATTERY from the Mimic Display Screen, the following screen comes up, displaying DC bus voltage and the charge or discharge current. This screen also shows BATTERY TEMPERATURE. Press SELECT to return to the Mimic Display Screen.

Figure 16 DC bus / battery status

DC BUS / BATTERY STATUS	
NUMBER OF BATT. ONLINE	1
DC BUS VOLT	540
BATT VOLT	472
BATT CURR	4.1 (CHG)
BATT TEMP	25 °C
LAST BATTERY TEST : 07/07/02	

DISCONTINUED PRODUCT

The DC BUS/BATTERY status screen displays the following real-time data:

- DC Bus Volts
 - Battery Volts
 - Battery Current (Chg/disch)
 - Battery Temperature (This reading is the temperature of the ambient air in the battery cabinet.)
 - Battery Time Remaining
3. **BYPASS INPUT.** Selecting BYPASS from the Monitor Mimic Display displays the following screen showing bypass input voltage and the bypass input frequency. Press SELECT to return to the Monitor Mimic Display.

Figure 17 Bypass input status

BYPASS INPUT STATUS						
	A	B	C	FREQ.	59.9	HZ
V L-L	213	213	214	PHASE DIFF	0	

The Bypass Input Block displays the following real-time data:

- Bypass AC Volts AB, BC, CA
 - Bypass Frequency
 - Bypass Phase Difference
4. **OUTPUT / LOAD.** Select LOAD from the Monitor Mimic Display screen to bring up this block. It displays total output power to the critical load in kVA and kW. The critical load current per phase is also displayed in this block. Note that kW is not displayed when the load is on the bypass line. During an overload condition, the time remaining before transfer is displayed at the bottom of the load box. Press SELECT to return to the Mimic Display Screen.

Figure 18 Output load status screen

OUTPUT LOAD STATUS						
	A	B	C	FREQ.	59.9	HZ
V L-L	205	203	207	<u>% OF RATED LOAD:</u>		
V L-N	120	117	118	KVA	42 %	
I	5	5	162	KW	42 %	
KVA	1	1	19	<u>OVL D COND (SEC.)</u>		
KW	1	1	15			

DISCONTINUED PRODUCT

The Output/Load status screen displays the following real-time data:

- Output AC Volts AB, BC, CA
 - Output AC Volts AN, BN, CN
 - Output Current A, B, C
 - Output kVA, kW, A, B, C
 - Output Frequency
 - % rated kVA and kW
 - Overload Condition (with timer in seconds)
5. **SYSTEM STATUS.** When the SYSTEM STATUS box on the Mimic Display Screen (**Figure 14**) shows a flashing FAULTS AND ALARMS message, highlight it and press SELECT. This displays information about faults and alarms. Fault messages are displayed in reverse video (highlighted - light on dark) while alarm messages are displayed in regular video (dark on light). Alarm messages activate the audible alarm until the ALARM SILENCE button is pressed. To clear a latching alarm, you must also press the ALARM RESET button after the alarm condition is corrected.

Faults and Alarms

The Liebert® Npower™ is designed to alert the Operator to system conditions that warrant careful monitoring and/or corrective action. A fault is an undesirable system condition that can cause further damage to the system or potentially drop the load if not acted upon. An alarm indicates an abnormal system condition significant enough to warrant being annunciated and logged. During normal operation no alarm messages should be present.

Figure 19 Active faults and alarms screen

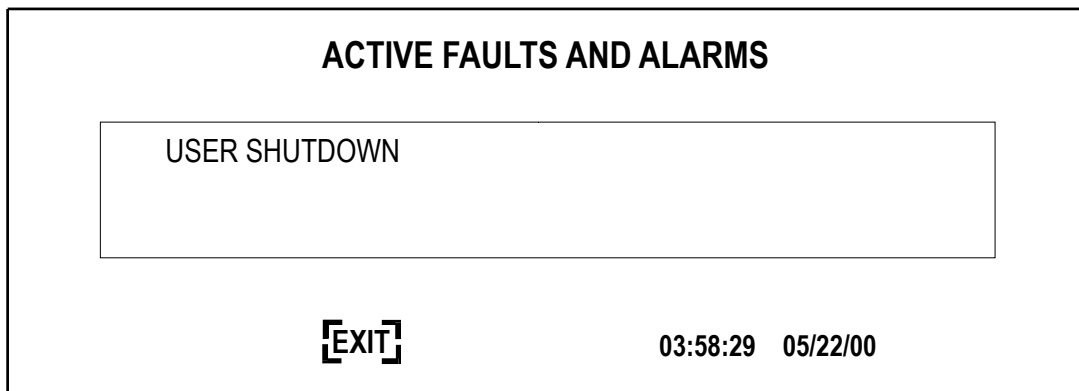

If input power is lost, the following screen will be displayed:

Figure 20 Active faults and alarms, loss of power

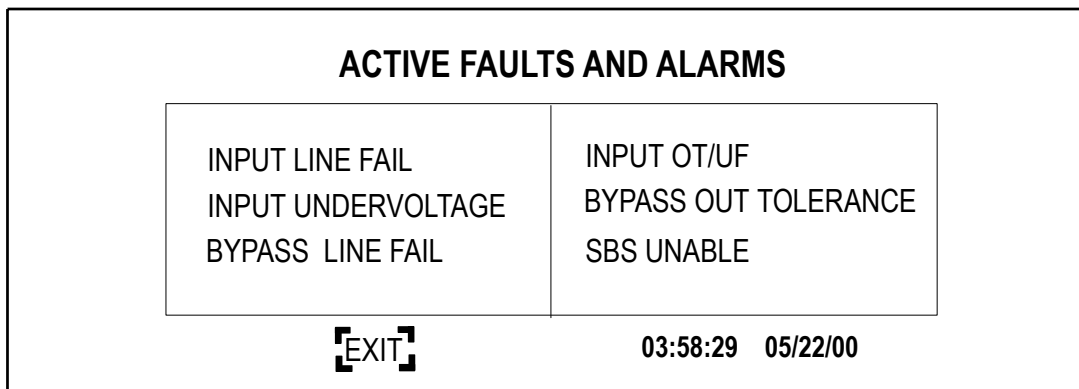

NOTE

There are 45 different fault messages and 95 different alarm messages. For a complete list refer to 3.4.1 - Faults and 3.4.2 - Alarms.

DISCONTINUED PRODUCT

3.3.2 Startup

There are two start up scenarios which can be followed depending on whether there is already power supplied to the UPS and the UPS is on Bypass, or there is no power to the UPS. Follow the appropriate instructions.

First Scenario

Power is not supplied to the UPS (Upstream breakers are open). Locate the Rotary Switch located on the inside of the cabinet on the lower right side as you face the cabinet. Turn the Rotary Switch to the Normal position. For a Single Input unit close the upstream breaker so that power is applied to the UPS. For Dual Input units close both the Input and Bypass line breakers so that power is applied to the Input of the UPS and the Bypass line. At this time, power will be applied to the load through the internal static bypass.

Figure 21 System ratings screen

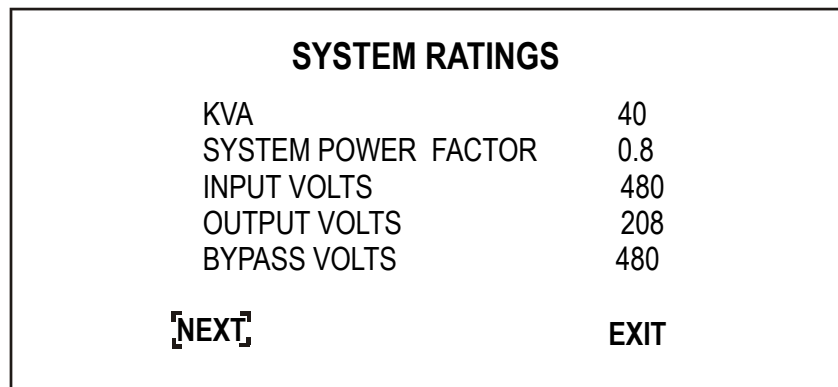

As soon as power is applied, you will see the SYSTEM RATINGS screen (Figure 21). These are the ratings of the unit that were programmed in at the factory. Using the arrow keys highlight SAVE & EXIT and push the SELECT button. This will advance you to the USER SETTINGS screen. The USER SETTINGS have been pre-set at the factory. However, they may be customized for your site. See 3.3.5 - Configuration Screens for detail information on configuration screens. You can change these configurations at any time. Use the arrow keys to move the cursor to SAVE & EXIT and push SELECT. This will move you to the MIMIC screen that will look like Figure 22. You are now ready to follow the instructions for automatic start up; see Auto Startup on page 28. Service technicians may alternately use the Manual Start Up procedure for troubleshooting purposes in Manual Startup on page 29.

Figure 22 Mimic display screen with load on bypass and switches closed

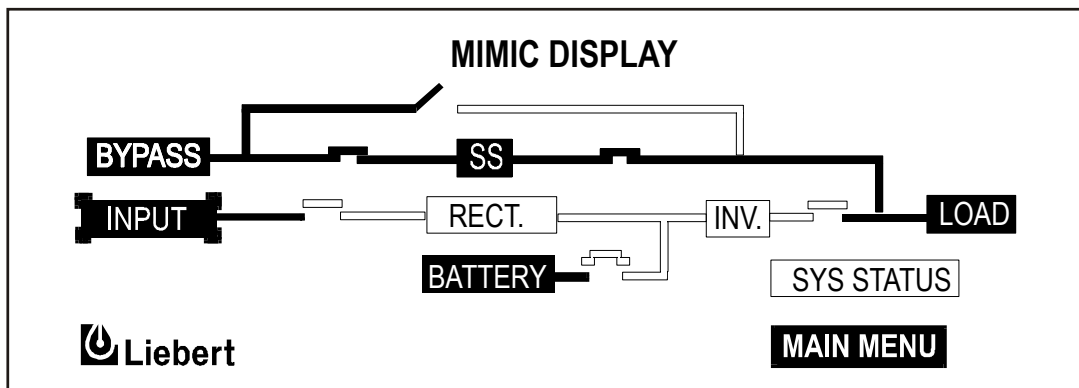

DISCONTINUED PRODUCT

Second Scenario

Power is supplied to the UPS and the UPS is supplying the load. (Upstream breakers are closed). The UPS should be showing either the SYSTEM RATINGS screen or the Mimic display. If the SYSTEM RATINGS screen is showing, use the arrow keys to select SAVE & EXIT and push SELECT. This will advance you to the USER SETTINGS screen. The USER SETTINGS have been pre-set at the factory. However, they may be customized for your site. See **3.3.5 - Configuration Screens** for detail information on configuration screens. You can change these configurations at any time. Use the arrow keys to move the cursor to SAVE & EXIT and push SELECT. This will move you to the MIMIC screen. Check the MIMIC screen to make sure the static switch contactors are closed. The screen should look like **Figure 22**. If the Static Switch Contactors are open (**Figure 24**), transferring to the NORMAL position will DISCONNECT THE LOAD. To close the Static Switch contactors, locate the Rotary Switch located on the inside of the cabinet on the lower right side as you face the cabinet. Turn the Rotary Switch to the SERVICE position. Wait for 10 seconds. Return the Rotary Switch to the BYPASS position. This should reset the Static Switch contactors to the closed position and the MIMIC panel should look like **Figure 22**. If the Static Switch contactors are closed, then the load is supported by Static Switch and you are clear to move the Rotary Switch to the NORMAL position and move on to **Auto Startup on page 28**. If the Static Switch contactors are not closed, repeat the above procedure. If this still does not close the static switch, contact Liebert® Services for assistance.



CAUTION

If on Static Bypass, make sure the Static Switch is closed (**Figure 22**) before turning the Rotary Switch to normal. If the Static Switch is not closed and the Rotary Switch is turned to the normal position, the load will be disconnected.

Figure 23 Startup / shutdown procedures screen

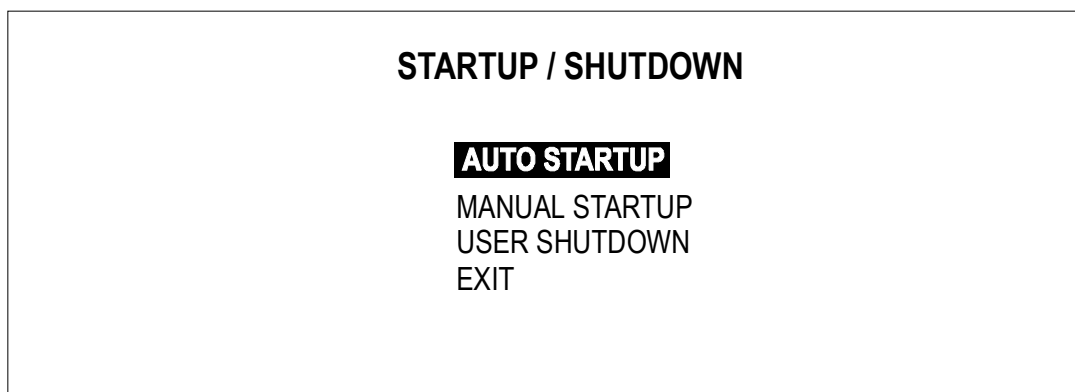

Auto Startup

Normally, the Operator will choose to start the system automatically for the sake of convenience. To begin the auto start-up sequence, select MAIN MENU from the MIMIC screen. This will bring up the MAIN MENU Screen (**Figure 9**). From this screen select STARTUP/SHUTDOWN. This will take you to the STARTUP/SHUTDOWN screen, **Figure 23**. Move the cursor to AUTO STARTUP and press SELECT. AUTO STARTUP mode starts the rectifier and inverter, and transfers the load to the inverter. The operator needs only perform one action when prompted: CLOSE MANUAL BATTERY BREAKER. This action must be performed promptly (within 90 seconds). Otherwise the startup operation is aborted and an error message will appear stating: UPS OPERATION CANNOT BE PERFORMED. Although no further operator interaction is required, the Operator has the option to abort the Auto sequence.

Once the Operator has manually closed the Battery Breaker, the UPS automatically becomes fully operational, at which point the Mimic Display Screen is displayed showing Normal Power Flow. See **Figure 10**.

Manual Startup

On occasion, a service technician may wish to start the UPS manually while performing diagnostic testing. The manual startup, like the auto startup, requires that the Rotary Switch be in the NORMAL position. To start the system manually, highlight MANUAL STARTUP and press the SELECT button on the navigation bar. This action brings up the MIMIC DISPLAY screen, prompting the Operator to close the Static Switch contactors.

Figure 24 Manual startup screen, close static switch contactors screen

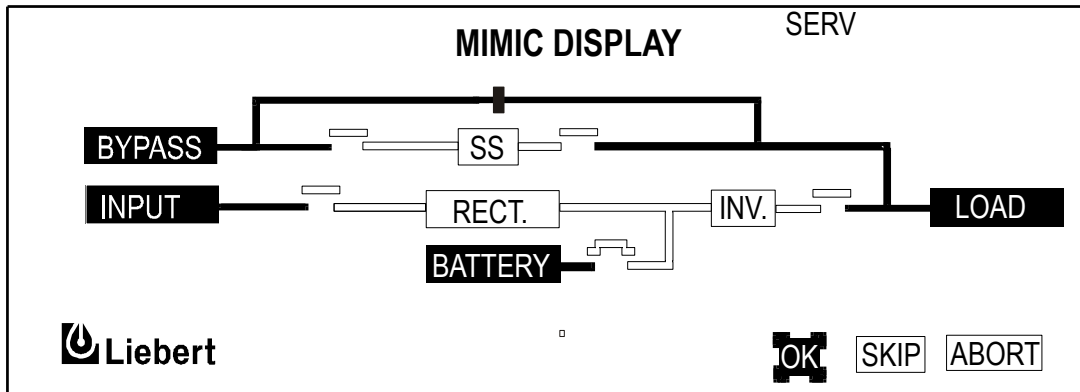

Press OK to close the SS contactors, turning on the Static Switch. Press SKIP only to proceed without closing the Static Switch contactors. Either selection brings up the screen enabling modification of input current limit.

Figure 25 Target and ramp values

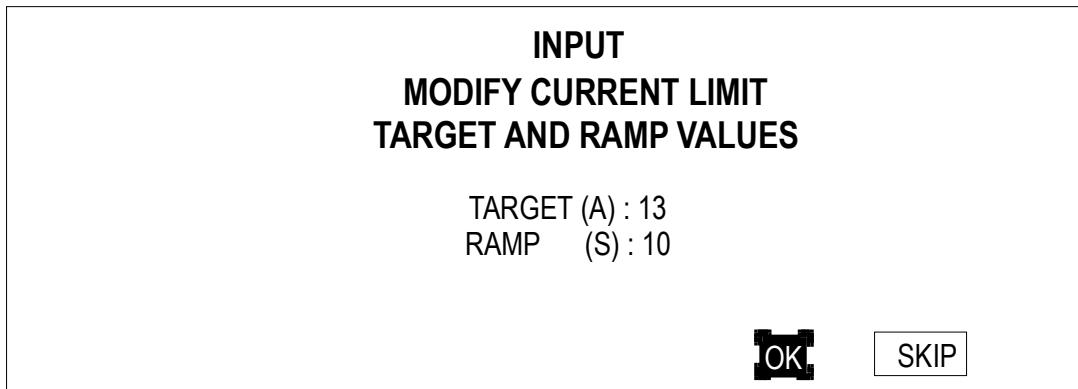

Press SKIP to proceed or OK to change values. If Operator selects SKIP, the Mimic Display screen is momentarily displayed, followed by the screen enabling modification of DC Bus Setpoint.

DISCONTINUED PRODUCT

Figure 26 DC bus setpoint screen

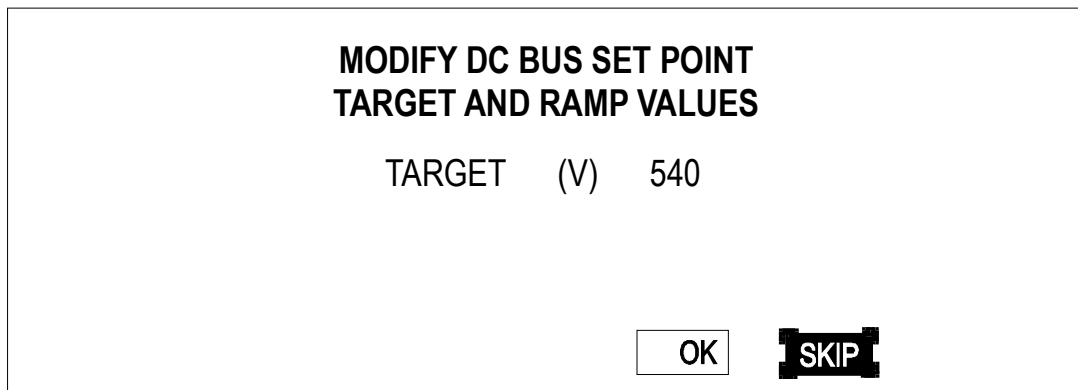

New Target and Ramp settings are temporary settings for diagnostic testing or special situations. Each time the UPS is placed online, the settings return to the default values. Custom T and R entries are only allowed when rotary switch is in Bypass position.

The Operator normally does not have to change Target and Ramp settings. Therefore, he should select SKIP and proceed to the next step which is to turn on the Rectifier and Inverter.

Operator is issued the prompt on the Mimic Display, “Turn on Rect.” Pressing OK will turn on the rectifier which will take up to one minute. If the rectifier does not turn on within two minutes, the UPS will automatically make a second attempt.

Next, Operator is issued the prompt, “Turn on Inv.” Pressing OK turns on the inverter, taking up to one minute. If it does not turn on within two minutes, the UPS will make a second attempt.

Next, Operator is prompted to “Close Batt CB.” The battery circuit breaker does not have to be closed to bring the unit online. This step can be skipped in both NORMAL and BYPASS positions. The CLOSE BATT CB screen will offer a choice of OK or SKIP. If you wish to move ahead without bringing the battery online, select SKIP.

Last, the Operator will see the MANUAL TRANSFER/RETRANSFER screen. To move the unit from BYPASS to UPS operation use the arrow keys to select RETRANSFER TO UPS and push the SELECT button.

At any time during the above sequences, the Operator can choose to abort the procedure. The load will remain on bypass while the rectifier and inverter are powered down. In addition, any internal failure will automatically inhibit startup.

From here on the Operator may monitor faults/alarms data and other information by navigating to primary screens from the Main Menu screen, or by navigating to secondary screens from any of the primary screens.

SIB External Maintenance Bypass

An External Maintenance Bypass Switch can be added by Liebert® or supplied by the Customer. The Liebert-supplied option is outlined in **Figure 27** and **Figure 28** for the single input and dual input options, respectively. The rotary switch has three independent power contacts on a common shaft. A set of auxiliary contacts is incorporated into the shaft to determine the power switch position. The auxiliary contacts, if provided will be connected to pins 9-10 of TB70 of the UPS module. The UPS module shipped from the factory will have pins 9-10 jumpered so that the UPS internal logic will ignore the External Maintenance Bypass switch conditions.

Figure 27 External maintenance bypass switch, dual-input UPS

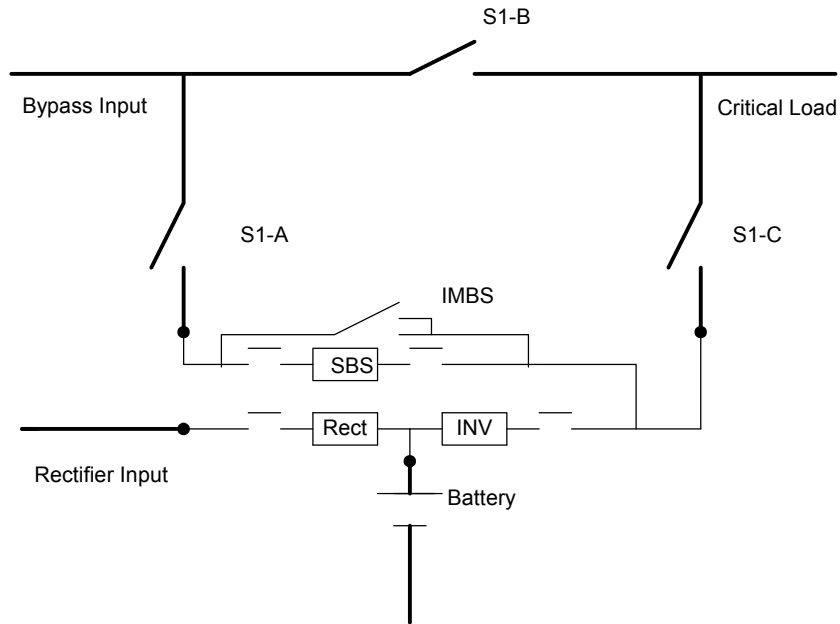
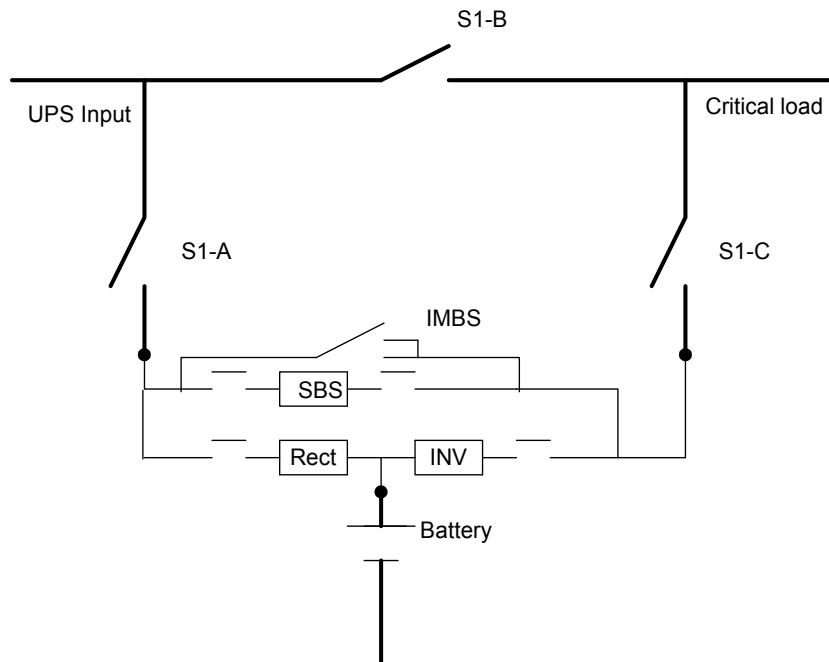

Figure 28 External maintenance bypass switch, single-input UPS



The table below summarizes the External Maintenance Bypass switch positions and actions.

Table 3 External maintenance bypass switch positions and actions

Switch position	S1-A	S1-B	S1-C	AUX
Maintenance (Service)	Open	Closed	Open	Open
Test (Bypass)	Closed	Closed	Open	Open
On Line (Transition)	Closed	Closed	Closed	Open
On Line (Normal)	Closed	Open	Closed	Closed

DISCONTINUED PRODUCT

When the External Maintenance Bypass switch is in Bypass or Maintenance position, the UPSC will assert the bypass contactor close signal and the output contactor open signal. It will also turn on the SBS. Automatic Retransfer operations will be disabled.

If the External Maintenance Bypass switch rotates from the Bypass or Maintenance to the Normal position, then the UPSC will keep the bypass in the ON state, thus keeping the critical bus powered via the bypass source. The user will be able to issue a “Manual Transfer to Inverter” command provided the retransfer conditions are satisfied. The user can also issue a shutdown or a start command.

If the External Maintenance Bypass switch rotates from the Normal to the Bypass or Maintenance position, the UPSC will assert the bypass contactor close signal and the output contactor open signal. It will also turn on the SBS. Automatic Retransfer operations will be disabled.

External Maintenance Bypass Switch Configurations

The External Maintenance Bypass Switch has three configuration options:

- External maintenance bypass installed with interlock option
- External maintenance bypass installed without interlock option
- Not installed

Table 4 External maintenance switch configuration options

External Maintenance Switch Options	Option Auxiliary Contact Status	User Prompt
Installed with Interlock Option	open = On Test position or Maintenance position, or jumper removed	Prompts the user to rotate to On Line position, Just before retransfer.
	closed = On “ON LINE” position (default jumper)	Manual or automatic start (one button) is allowed all the way to load being On-line
Not installed	open = jumper removed	Prompts the user to install jumper just before retransfer”
	closed = default jumper	Manual or automatic start (one button) is allowed all the way to load being On-line
Installed without interlock option	Open = Jumper removed	Prompts the user to install jumper just before retransfer”
	Closed = default jumper	Prompts the user to verify the switch is in on-line position before a retransfer is allowed

Regardless of how the configuration is set, if the auxiliary contacts are open, the user is unable to issue a retransfer command through the manual transfer / retransfer screen.

If the option is installed and the auxiliary contact status is read as switch is in the Bypass or Maintenance position, the “critical load shutdown” message reads “UPS off”.

Multiple Battery Cabinets

The Liebert® Npower™ system offers an option allowing for the installation of more than two battery cabinets. The option consists of a Multiple Battery Breaker (MBB) board that mounts on the control door and an Input Contact Isolator (ICI) board that mounts in the option area (See the Multiple Battery Breaker Option in the options manual.)

The ICI board allows the Liebert Npower system to sense multiple battery cabinets, and the MBB board allows the UPS to support multiple battery cabinets by supplying power to the UVR coil of additional battery cabinets.

To access the screen for setting the number of battery cabinets in the system, navigate from the MAIN MENU to CONFIGURATION to SYSTEM SETTINGS, page 3. Select NUMBER OF BATTERY CABINETS to bring up the following password-protected screen.



Figure 29 Set number of battery cabinets screen

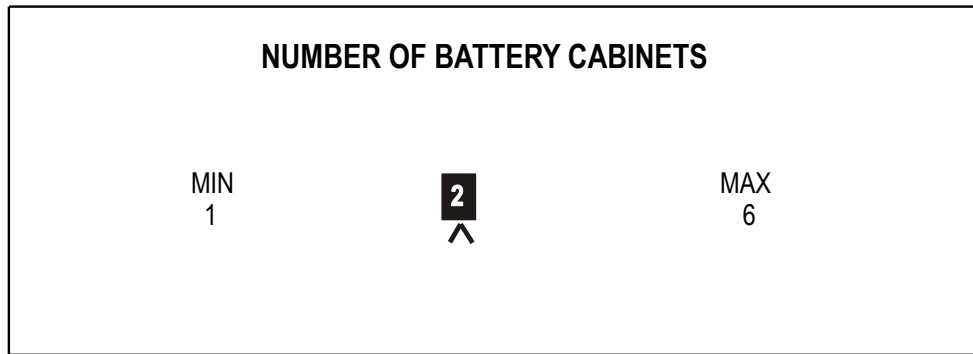

Set the number of battery cabinets by changing the number in the highlighted box. Pressing SELECT will save this information and return Operator to the System Settings Screen.

3.3.3 Shutdown

To shut down the UPS, navigate to the MAIN MENU, and select STARTUP/SHUTDOWN. This action will display the STARTUP/SHUTDOWN screen. From there, highlight USER SHUTDOWN and press SELECT. The following figure will appear.

Figure 30 User shutdown screen

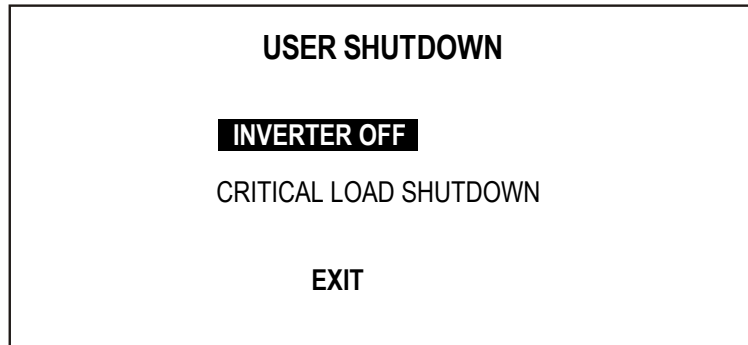

The Operator can invoke two types of shutdowns from this interface screen:

- Transfer Load (Inverter Off). Selecting this option transfers the load to Bypass and turns off the Rectifier and Inverter.
- Critical Load Shutdown. Selecting this option enables a total system shutdown for purposes of servicing or repair. The critical load will be dropped once the command is acknowledged by the controls. Once the Operator has initiated this command, a final warning message will be issued that “The UPS load will be dumped if you continue.” If accepted (“Continue”), the system will shut down.

When Operator selects TRANSFER LOAD (INVERTER OFF), the MANUAL TRANSFER/RETRANSFER screen is displayed. This allows the Operator to transfer the critical load in and out of the static switch bypass. This screen can be accessed only when the rotary switch is in Normal position. The screen is accessed from the MAIN MENU.

Figure 31 Manual transfer / retransfer screen when transfer is allowed

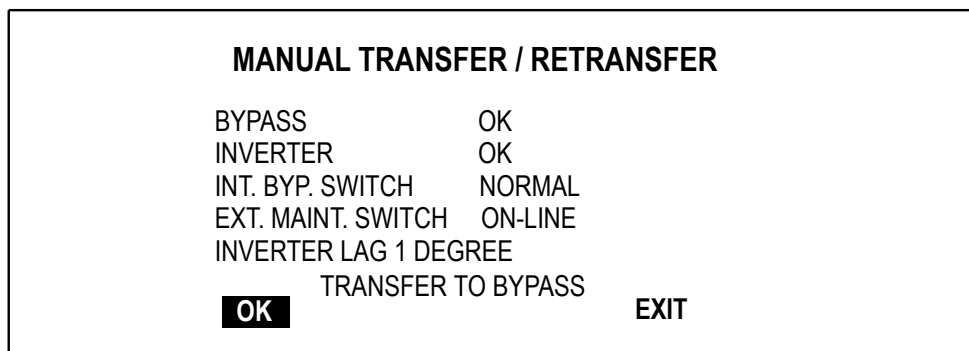
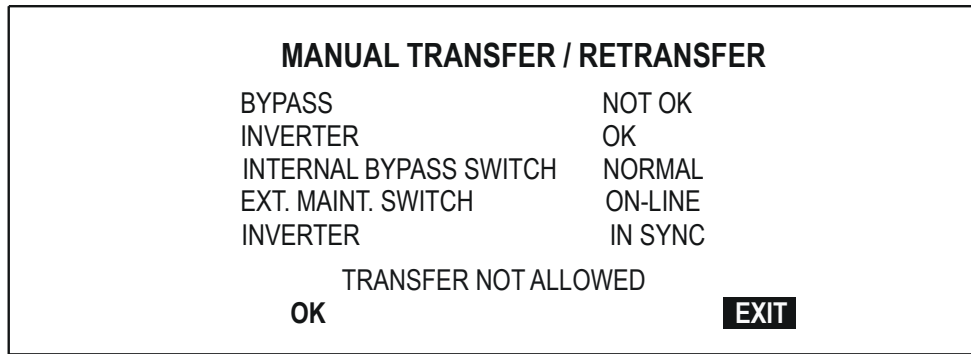

Figure 32 Manual transfer / retransfer screen when transfer is not allowed



The message Retransfer to UPS or Transfer to Bypass will appear depending on status of the critical load. The operator has two choices: Either to accept OK or EXIT. If a transfer or retransfer is not allowed, the FLASHING message Transfer Not Allowed is displayed. Press EXIT to return to the MAIN MENU.

For more information, see **3.3.6 - Manual Transfer**.

3.3.4 Status Reports

Status Reports contain sequential information about fault and alarm signals. To access the Status Report screens, navigate to the MAIN MENU and highlight STATUS REPORTS. Press the Select button and the following STATUS REPORTS screen is displayed

Figure 33 Status report screen

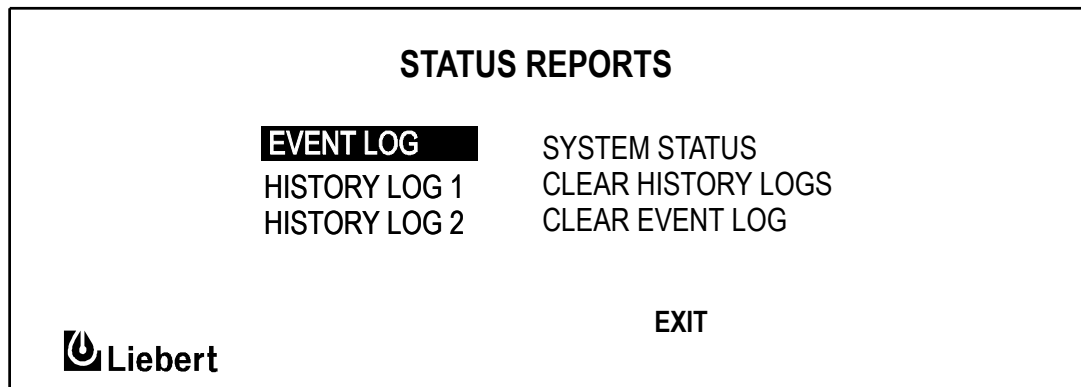

The Status Report screen is divided into six submenus: EVENT LOG, HISTORY LOG 1, HISTORY LOG 2, SYSTEM STATUS, CLEAR HISTORY LOGS, and CLEAR EVENT LOGS.

To look at any of the reports, do the following:

1. From the Status Reports screen, press the Up or Down button to move the highlighted cursor to the desired selection.
2. Press the Select button to view the desired report page.

To return to the Main Menu, highlight EXIT and press Select.



NOTE

*The Event Log and History Log reports can be displayed on a remote terminal. For more information see **3.5 - Communication Interfaces**.*

Event Log

The Event Log screen displays the faults, alarms, and status messages. Every message will have a time and date stamp.

The Event Log is a sequence of messages or events captured in individual frames. See the following section on HISTORY LOGS for more information about frames.

The following three screens show the last 3 in a series of 20 messages. Notice that 20 messages have accumulated in this example, and that marker moves from right to left as earlier messages are viewed. The number of events prior to the alarm are displayed by an arrow pointing to the left, and the number of events following the alarm is illustrated by an arrow pointing to the right. The maximum number of events that can be recorded is 512 events.

To view a previous event, highlight PREV and press SELECT.

Figure 34 Event log report screen showing most recent event

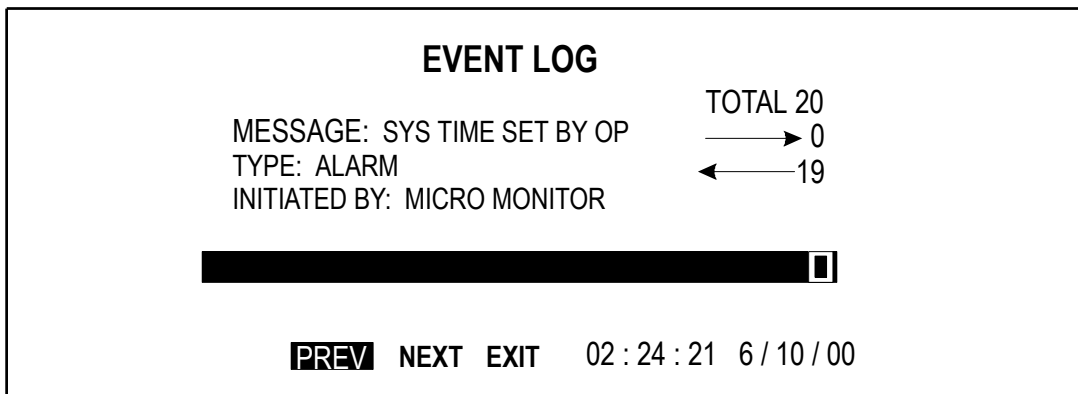

Figure 35 Event log report screen showing previous event

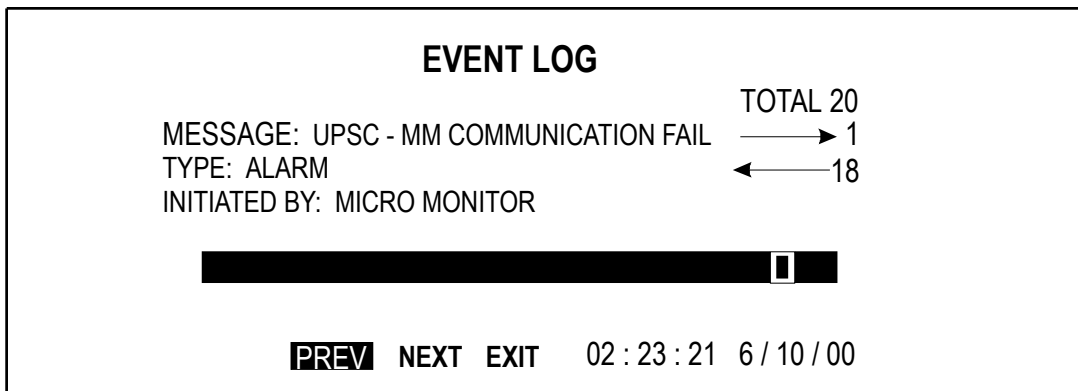
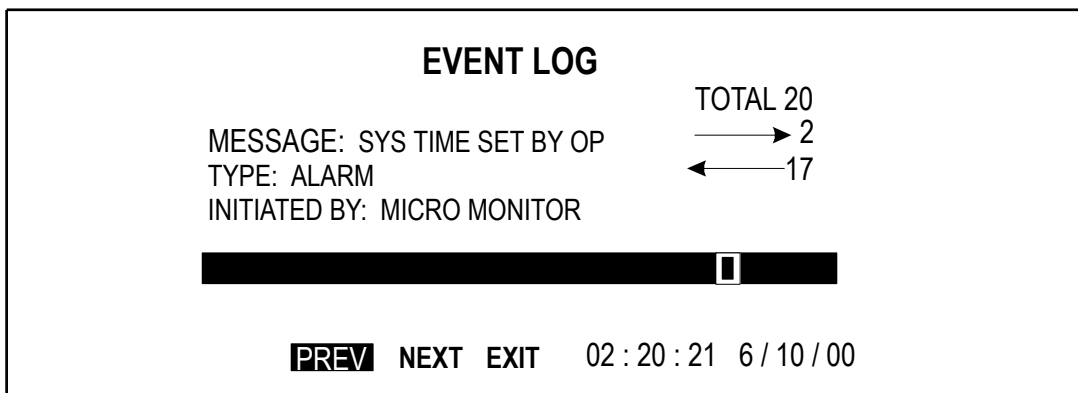

Figure 36 Event log report screen showing previous event



DISCONTINUED PRODUCT

History Logs

The History log contains pertinent data recorded just before and after an event that triggers a significant action such as an inverter failure. There are two History logs, each consisting of 64 frames. Each frame is a sequential snapshot of UPS-generated parameters. The UPS records these frames continuously at 4 millisecond intervals during normal operation. When a fault occurs, the UPS stores 40 frames prior to the triggering event, the frame of the triggering event, and 23 frames immediately following the triggering event.

The frames are numbered -40 +23 with frame 0 designated as the triggering event that initiates the fault or alarm condition. The Operator can go back 40 frames from the triggering event and forward 23 frames.

There are nine possible triggering events:

- Rectifier fail
- Battery Low Transfer
- Output Overvoltage Transfer
- Output Undervoltage Transfer
- Inverter Fail
- Inverter Overload Transfer
- Heatsink Overtemp Limit
- Outlet Air Overtemp Limit
- Fault Load Transfer to Bypass

The data logged in each frame consists of metering data, machine status information, active faults/alarms and fault/alarm conditions.

Figure 37 History log metering report screen

HISTORY LOG 1 P1 - METERING							14 : 18 : 49 02 / 10 / 00	
	OUT-V (L - N)	OUT (I)	IN-V (L - L)	IN (I)	LOAD (KVA) (KW)	DC	FREQ (HZ)	
A	120	10	208	52	74 59	540 V	60.0 OUTPUT	
B	120	10	208	52	74 59	+ 65 A	60.0 INPUT	
C	120	10	208	52	74 59	124 C		

PREV NEXT **STATUS** ALARMS EXIT FRAME 0

The default page is the METERING page, which provides the following data:

- 3 phase Output Volts (L-N)
- 3 phase Output I (amps)
- 3 phase Input volts (L-L)
- 3 phase Input I (amps)
- 3 phase load kVA
- DC Bus Volts, DC I (charge + discharge -)
- Input Frequency and Output Frequency
- Battery Temperature

DISCONTINUED
PRODUCT

The second page is the STATUS, which includes:

- Static Bypass Switch Line (Open/Closed)
- Static Bypass Switch Load (Open/Closed)
- Input Contactor (Open/Closed)
- Output Contactor (Open/Closed)
- Trap Filter (On/Off) (If installed)
- Int. MBP (Normal/Bypass Service)
- Ext. MBP (Open/Closed)
- Battery CB (Open/Closed)
- SBS (On/Off)
- Rectifier (On/Off)
- Inverter (On/Off)

Figure 38 History log status report screen

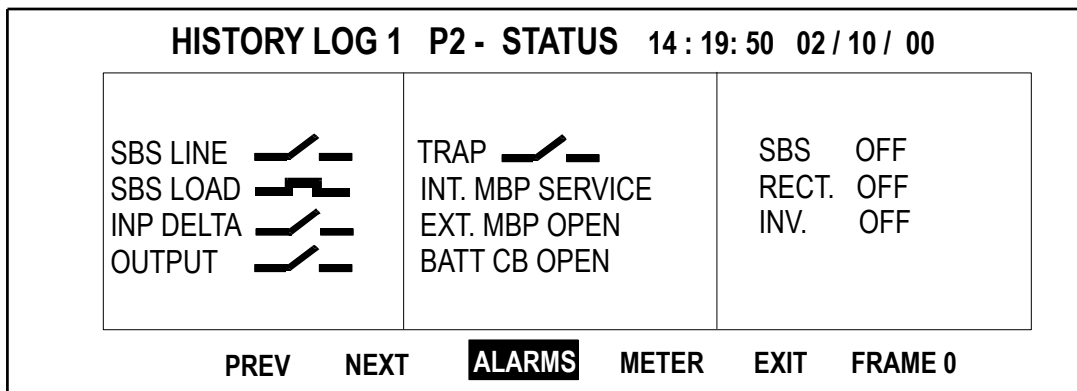

The last page includes faults. The alarm conditions that cause the History Status buffer to store and freeze data are:

- Rectifier fail
- Battery Low Transfer
- Output Overvoltage Transfer
- Output Undervoltage Transfer
- Inverter Fail
- Inverter Overload Transfer
- Heatsink Overtemp Limit
- Outlet Air Overtemp Limit
- Fault Load Transfer to Bypass
- Transfer Failed Shutdown

DISCONTINUED
PRODUCT

Figure 39 History log faults/alarms report screen

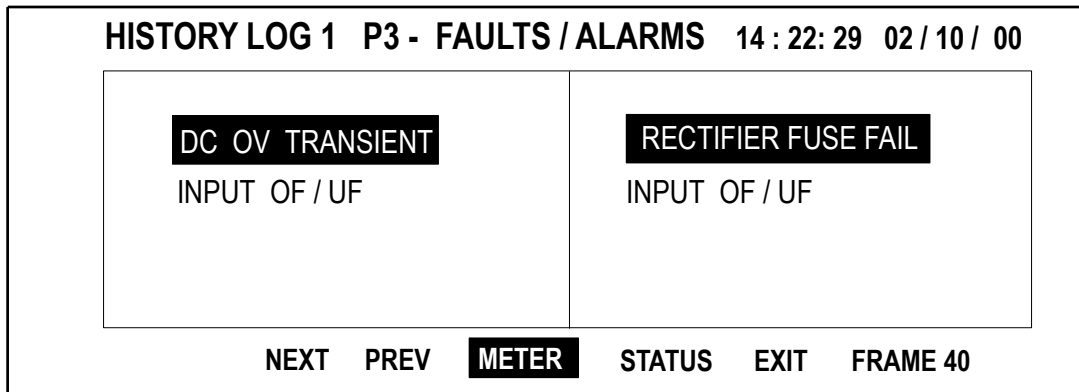

As previously mentioned, faults are shown in reverse video, and alarms in regular video. For a complete list of all the alarm messages and corrective actions for these faults, refer to **Table 7 - Alarms, functions, and corrective actions**.

**NOTE**

The Emergency Off and Hardware Shutdown alarms will also freeze the History Status buffer with the Auto Transfer to Bypass alarm (if the load is on the UPS system when the alarm condition occurs).

The History Status buffer does not resume collecting new frames until the fault is cleared.

3.3.5 Configuration Screens

The Configuration Screens are used to set specific parameters or to view settings configured by the factory or Liebert® Services. To access the System Configuration Screens, go to the Main Menu, move the highlighted cursor to SYSTEM CONFIGURATION, and press Select.

Figure 40 Configuration screen

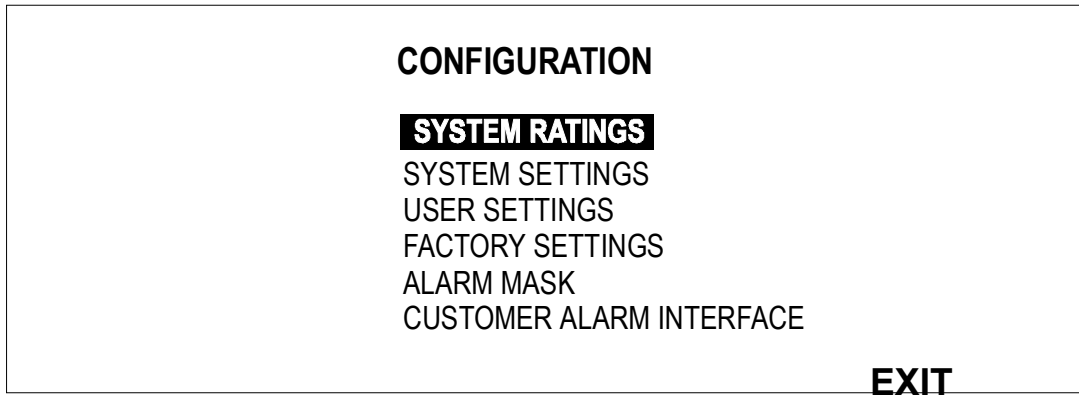

The System Configuration screen lists parameters that can be changed to adjust your UPS module to your site requirements. Some of the information displayed is factory set and should only be changed by Liebert Services. Parameters that can be adjusted by the Operator include date, time, auto dial number, and modem baud rate.

The System Configuration screen is categorized as a Security Access screen. This means that anyone may review the present parameters, but only authorized Operators may make changes. See **3.2 - Security Access and Passwords** for more information on Security Access and Passwords.

The first time the UPS is powered up (by Liebert Services), it allows the Operator to navigate through all of the menu options in order to program the Non Volatile RAM. This is referred to as the COLD START. Thereafter, only the SYSTEM RATINGS and Operator SETTINGS can be changed without Security Access.



NOTE

If Operator accidentally sets a site parameter digit to a wrong value, return to the System Configuration screen, navigate to the desired screen, and re-set.

System Ratings

System rating parameters are normally entered by the factory or Liebert Services.

To get to the System Ratings screen, begin at the Main Menu. Using the arrow keys, move to Configuration and press SELECT. This brings up the Configuration screen. (See **Figure 40**).

From the Configuration screen, highlight System Ratings and press SELECT.

Figure 41 System ratings, page 1

SYSTEM RATINGS	
KVA	40
SYSTEM POWER FACTOR	0.8
INPUT VOLTS	480
OUTPUT VOLTS	208
BYPASS VOLTS	480
[NEXT]	EXIT



NOTE

The only time the System Ratings can be changed is when the UPS is first powered up. After that, they remain locked.

Pressing NEXT at the System Ratings screen will bring up page 2 of System Ratings below.

Figure 42 System ratings, page 2

SYSTEM RATINGS	
DC BUS VOLTS	540
INPUT FREQUENCY	60.0
OUTPUT FREQUENCY	60.0
[PREV]	EXIT

System Settings

The System Settings are multiple screens that are used for setting the date, time, language, ID number, Tag number and other parameters.

The first page of the System Settings screen can be accessed by highlighting Systems Settings on the Configuration screen (**Figure 40**) and pressing SELECT.

Figure 43 System settings screen, page 1

SYSTEM SETTINGS	
DATE	01/05/2001
TIME	11: 16: 441
LANGUAGE	ENGLISH
ID NUMBER	00000000
TAG NUMBER	00000000
[NEXT] CANCEL SAVE & EXIT	

Date

To set the system date:

- From the System Settings screen, press the Up or Down button to move the highlighted cursor to DATE.
- Press Select. The DATE screen will appear.
- Press Select to move the arrow to the next digit to the right. When the arrow is on the digit to be changed, press the Up button to increase the number or the Down button to decrease it. Press Select to set the value and move to the next digit.
- After the correct month/day/year has been set, press Select again to return to the System Configuration screen.

Figure 44 Date setting screen

<p>CURRENT DATE</p> <p>01/20/2002</p>

Time

To set the system's real time clock, do the following:

1. From the System Configuration screen, press the Up or Down button to move the highlighted cursor to TIME.
2. Press SELECT. The TIME screen will appear.
3. Press SELECT to move the arrow to the next digit to the right.
4. When the arrow is on the digit to be changed, press the Up or Down button to increase or decrease the hour/minute/ second number. Press SELECT to set the value and move to the next digit.
5. After the correct hour/minute/second has been set, press SELECT again to return to the System Configuration screen.



NOTE

1. *Precise Date and Time functions are required for accurate archival and event history purposes.*
2. *Both the Date and Time can be set from a remote terminal. Refer to Section 3.5 - Communication Interfaces.*

Figure 45 Time setting screen

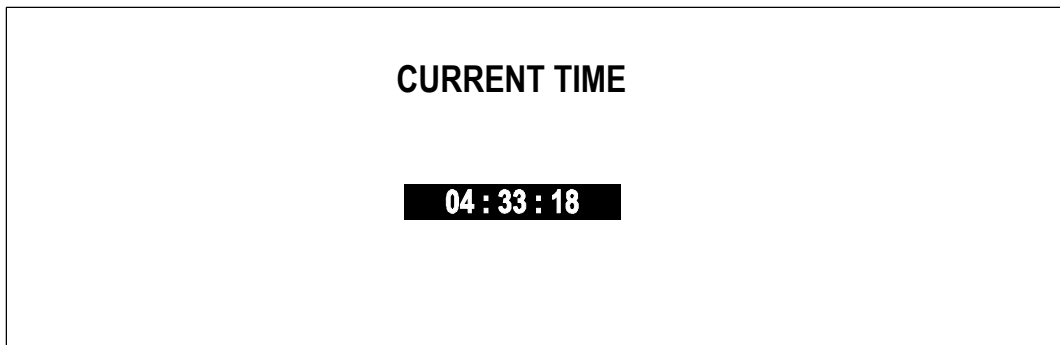
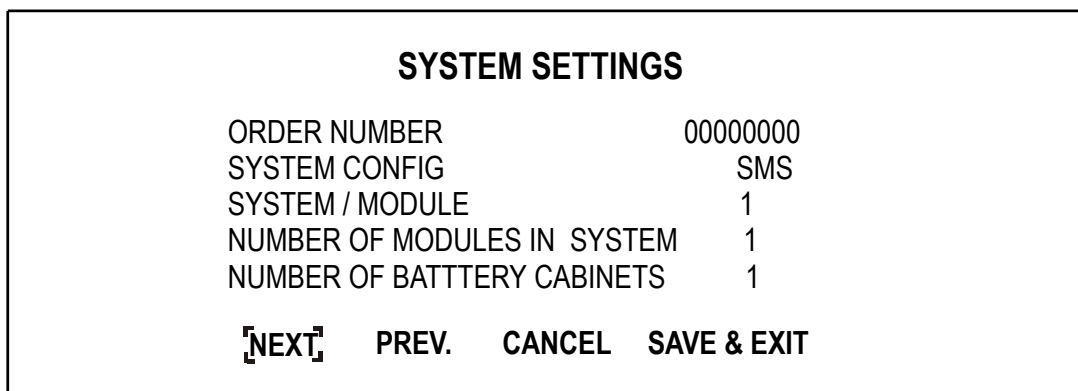
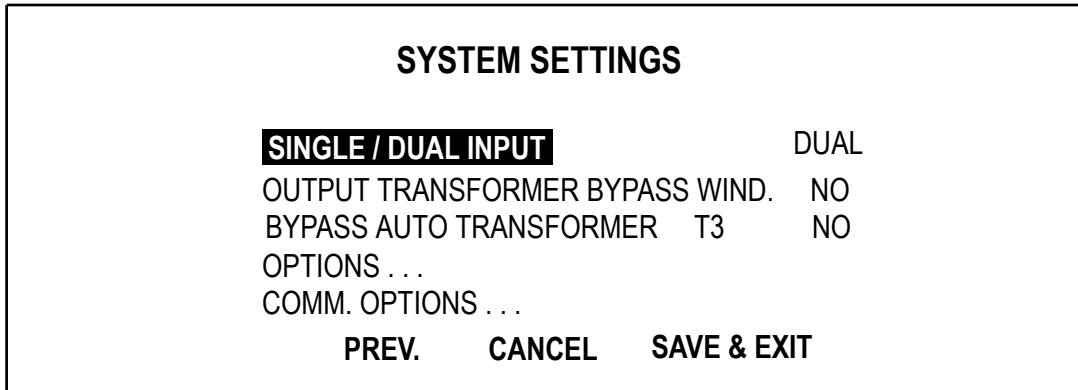

Figure 46 System settings, page 2



To continue configuring the system, highlight NEXT and press SELECT.

Figure 47 System settings, page 3



The Single / Dual Input Screen is password protected. (See 3.2 - Security Access and Passwords for more information on Security Access and Passwords.) After highlighting Single / Dual Input from the System Settings Screen, and pressing SELECT, the following screen will appear.

Figure 48 Enter password screen

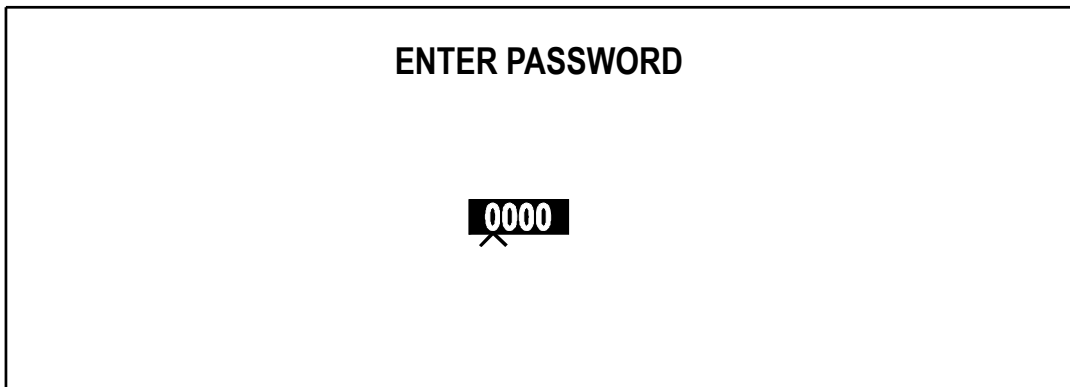

You must enter your secure password to access the next screen. The position of each of the four digits of the password is indicated by the mark below the zero. The system will remain password free for five minutes, allowing changes to be made.

Highlighting either Single or Dual and pressing SELECT saves changes and returns the Operator to the System Settings screen.

Figure 49 Single /dual input screen

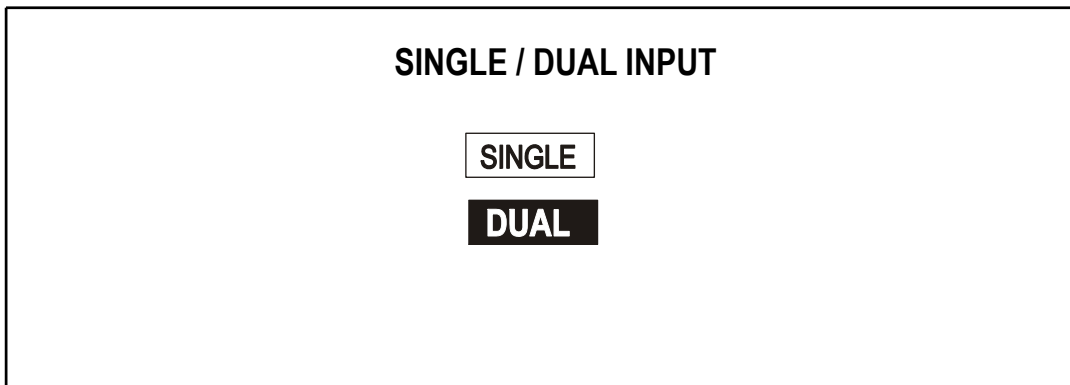

Options

This multiple-page screen, accessed from the third page of the SYSTEM SETTINGS screen, enables and disables optional features which might or might not be installed in your UPS. To enable or disable one of these options, do the following:

1. Highlight the option you wish to enable or disable.
2. Press UP or DOWN to toggle between enabled or disabled.
3. Press SELECT to set the desired status.



NOTE

Some of the options appearing on the following screens are reserved for future development.

Figure 50 Options screen, page 1

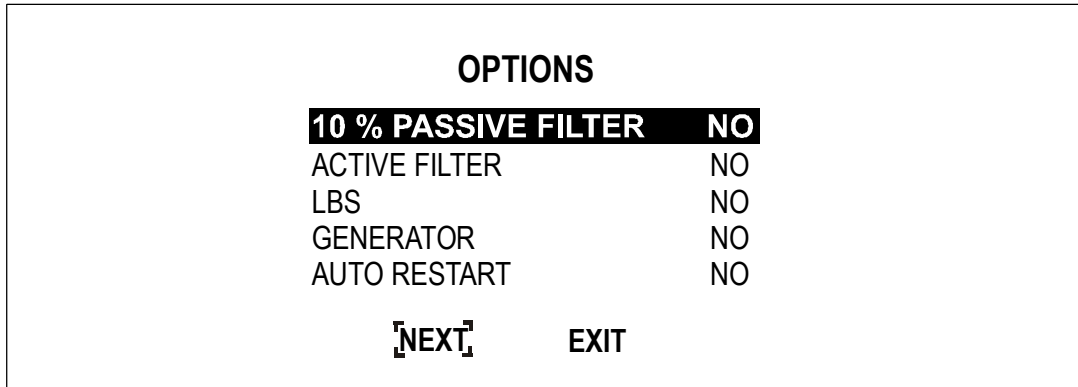

Highlighting 10% PASSIVE OPTIONS and pressing SELECT will bring up the following screen allowing the Operator to decide whether or not the input trap filter should be disconnected at light loads to prevent a leading power factor at the input. For more information, see Input Trap Filter in the options manual.

Figure 51 10% passive filter settings screen

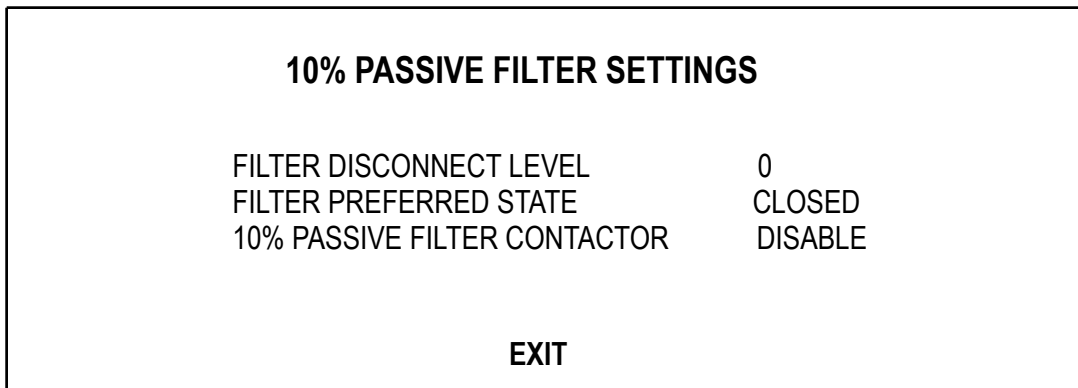

Figure 52 Options screen, page 2

OPTIONS	
12 PULSE RECTIFIER	6 PULSE
BATTERY GND FAULT	NO
GREEN MACHINE	NO
FREQUENCY CONVERTER	NO
LINE DROP COMPENSATION	NO
[NEXT]	PREV. EXIT

Figure 53 Options screen, page 3

OPTIONS	
ALTERNATE POWER POLE FAN	NO
AUX. TEMP.	NO
SFA	NO
MOTORIZED BATT. BREAKER	MANUAL
BATT. CELL MONITOR	NO
[NEXT]	PREV. EXIT

Figure 54 Options screen, page 4

OPTIONS	
EXTERNAL MAINT. BYPASS	NO
[PREV]	EXIT

DISCONTINUED
PRODUCT

Communication Options

Communication options are the various options that enable the operator to view data from remote locations and to program the type of data to be viewed. For detailed information, see Section 3.5 - **Communication Interfaces**.

The communication options screens can be accessed from the third page of the System Settings screen. (See **Figure 47**.)

Figure 55 Communication options Screen, page 1

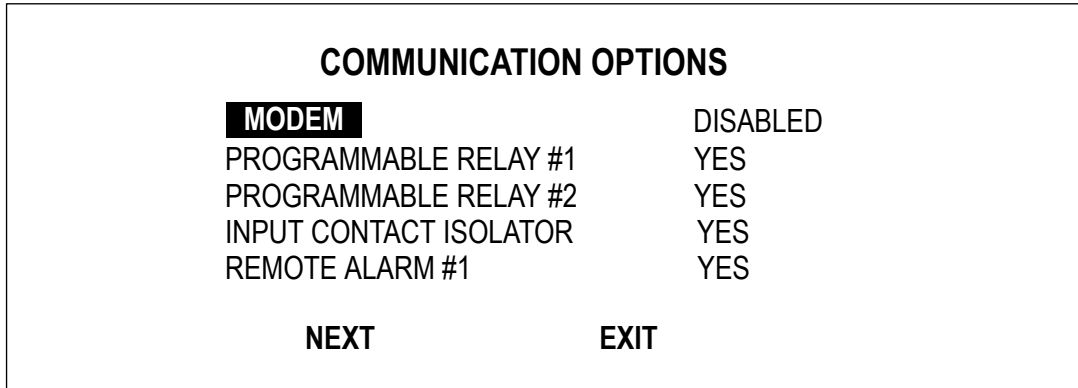

The Internal Modem Option allows the system to dial out or receive incoming calls. To set dialing features, and to enable internal or external modem, press **MODEM** on the first page of the Communications Options screen. The Auto Dial screen will be displayed.

Figure 56 Auto dial screen

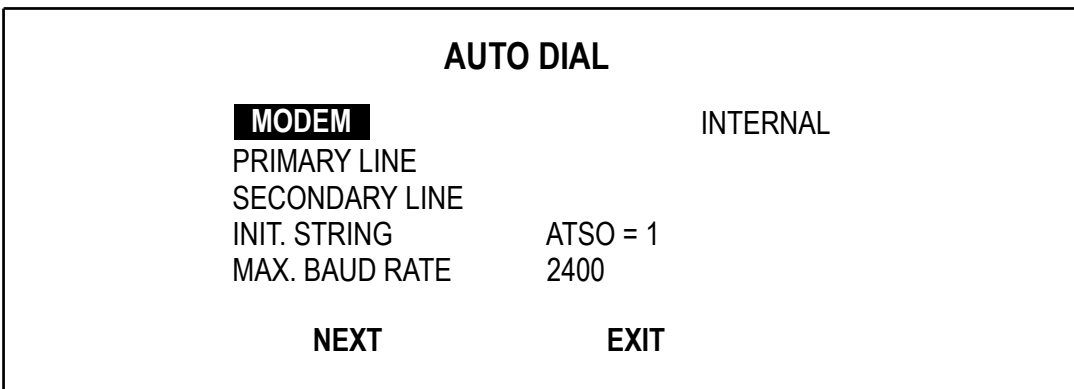

To get to the Modem Selection screen, highlight **MODEM** and press **SELECT**. The following screen will come up showing that the modem is disabled.

Figure 57 Modem selection screen

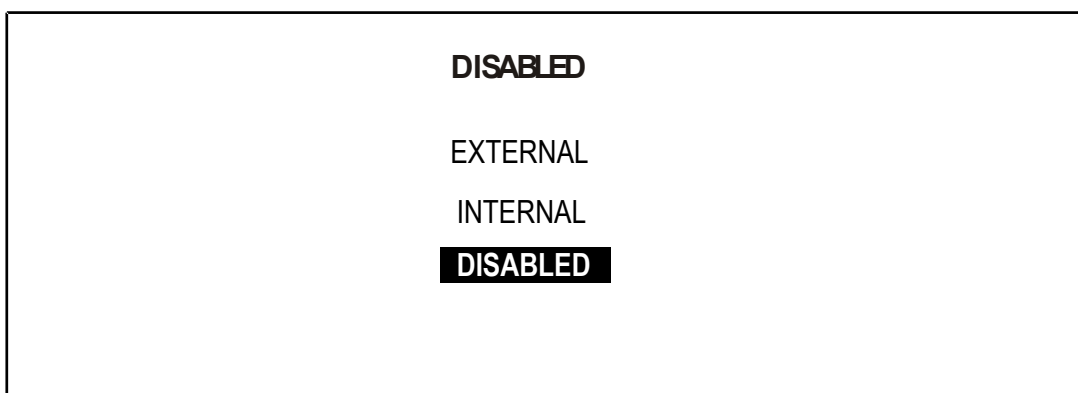

DISCONTINUED PRODUCT

To enable the modem, highlight INTERNAL or EXTERNAL and press SELECT. The Auto Dial screen will return (**Figure 56**) except instead of DISABLED, the message will read INTERNAL or EXTERNAL.

After enabling the modem, the Operator can proceed to configure Auto Dial settings at the AUTO DIAL screen. To input the phone number for the primary line, highlight PRIMARY LINE and press SELECT. The Operator can input up to 20 digits.

In a similar manner, the Operator can input the numbers for the secondary line.

To set the initialization string, highlight INIT STRING and press SELECT. The default for the internal modem is ATSO = 1. To change this setting, highlight INIT. STRING. After making the change, press SELECT repeatedly until the cursor moves to the end of the line. Pressing SELECT one more time will return the previous screen. **Figure 56 - Auto dial screen.** Consult the owner's manual for the external modem for help in setting the initializing string for this modem.

Next, the Operator can change the setting for the maximum baud rate by highlighting MAX BAUD RATE and pressing SELECT. A screen will appear allowing the Operator to select 2400 or 9600.

From the Auto Dial screen, the Operator can access the second page by bracketing NEXT, and pressing SELECT. This action will bring up the following screen.

Figure 58 Auto dial screen, page 2

AUTO DIAL	
MODEM HEALTH CHECK	EVERYDAY
AUTO DIAL IN	YES
AUTO DIAL OUT	YES
PAGER	NO

The settings for Modem Health Check, Auto Dial In, and Auto Dial Out, can be changed by highlighting the item and pressing SELECT, which will bring up the appropriate screen

To enable the pager and configure settings, highlight PAGER and press SELECT. The following screen will come up.

Figure 59 Pager support configuration

PAGER SUPPORT CONFIGURATION	
PAGER ENABLED	
PAGER NUMBER	
PAGER PIN	8773886786

A password is required to enter a pager number and change the pager pin number. See **Figure 48** and **Section 3.2 - Security Access and Passwords**. Press SELECT will return the Operator to the Communications Options Screen. (See **Figure 55**.) To go to the second page of the Communications Options Screen, bracket NEXT and press SELECT. The following screen will come up.

Figure 60 Communications options screen, page 2

COMMUNICATION OPTIONS	
REMOTE ALARM #2	NO
REMOTE ALARM #3	NO
SITESCAN	NO
NIC	NO
AS 400	NO
[NEXT]	PREV. EXIT

Select NEXT to go to the Communication Options screen, third page.

User Settings

The User Settings are accessed from the Configuration Screen (Figure 40).

Figure 61 User settings screen, page 1

USER SETTINGS	
OUTPUT PLL PHASE ADJUST	0.0
OUTPUT PLL SLEW RATE	0.5
OUTPUT PLL SYNC RANGE	1.0
DC BUS FLOAT VOLT	540
BATT. CHARGE I LIMIT	1.6
[NEXT]	CANCEL SAVE & EXIT

Figure 62 User settings screen, page 2

USER SETTINGS	
BATT. TIME LOW WARNING	5
BATT. TIME (T 1) AT 100%	15
BATT. TIME (T 2) AT 50%	45
BATT. EOD LOWER SET POINT	384
BATT. EOD UPPER SET POINT	427
[NEXT]	PREV. CANCEL SAVE & EXIT

Figure 63 User settings screen, page 3

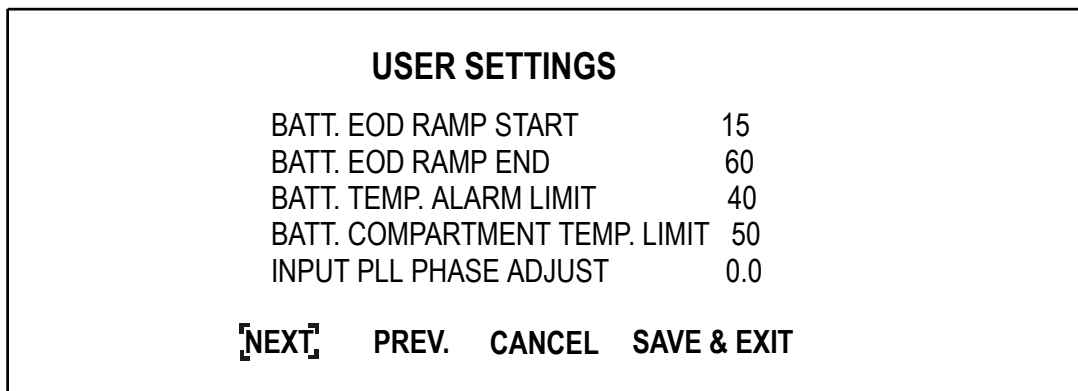

Figure 64 User settings screen, Page 4

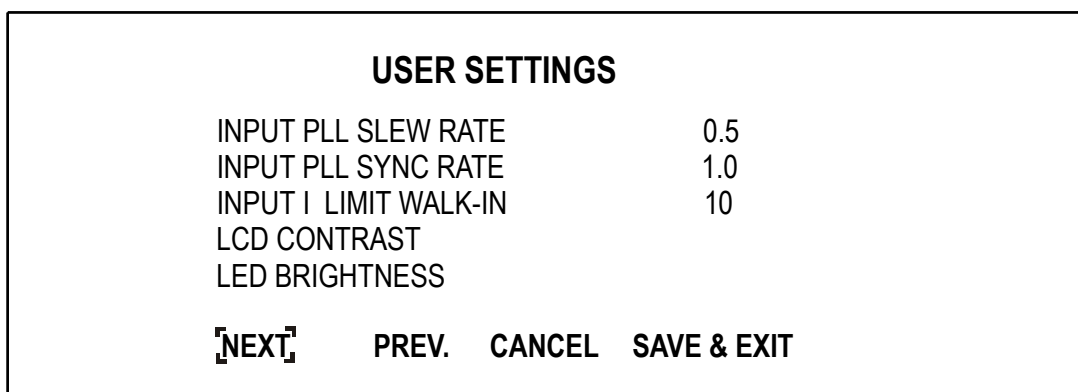
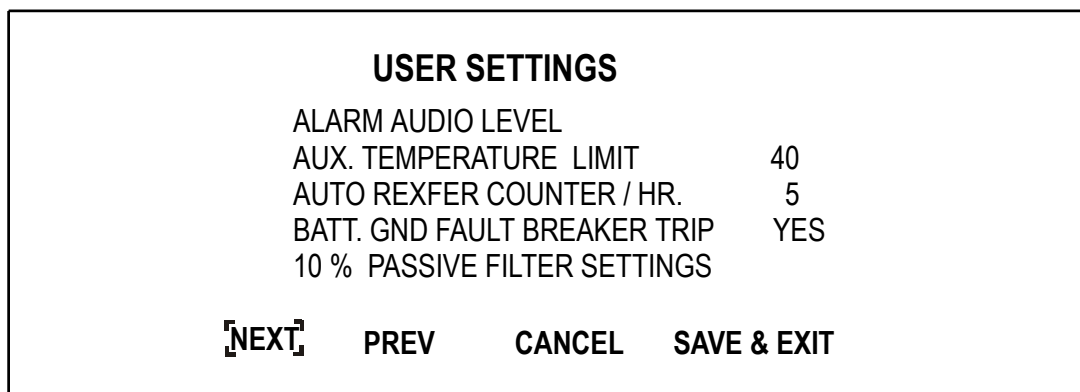

Figure 65 User settings screen, page 5



Highlighting 10% PASSIVE FILTER SETTINGS will bring up the following Operator--interactive screen.

Figure 66 10% Passive filter settings screen

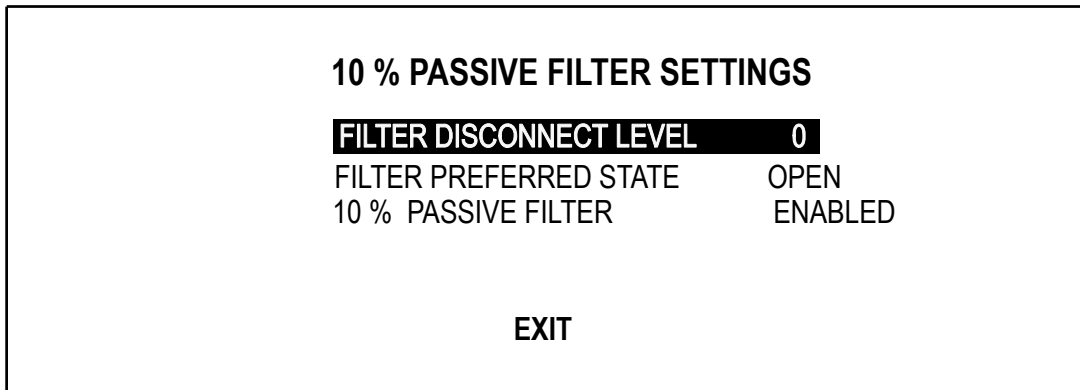
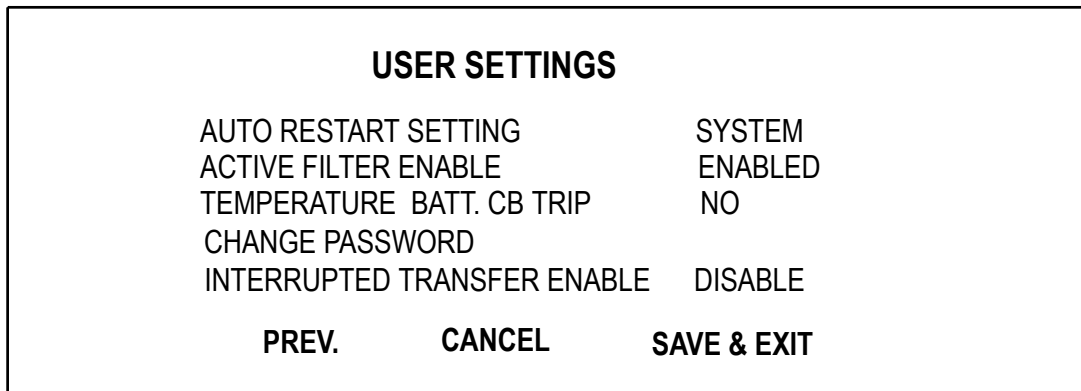

Figure 67 User settings screen, page 6



Factory Settings

Figure 68 Factory settings screen

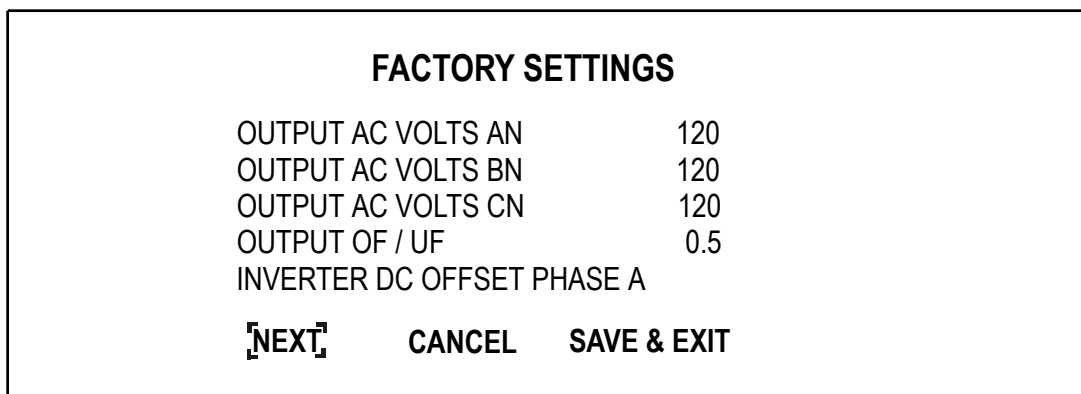

Figure 69 Factory settings screen, page 2

FACTORY SETTINGS	
INVERTER DC OFFSET PHASE B	
INVERTER DC OFFSET PHASE C	
INPUT I LIMIT WITH TRAP	164.1
INPUT I LIMIT WITHOUT TRAP	190.8
INPUT I LIMIT ON GENERATOR	100
<input type="button" value="NEXT"/> PREV. CANCEL SAVE & EXIT	

Figure 70 Factory settings screen, page 3

FACTORY SETTINGS	
INPUT PID LOOP	
ON GENERATOR DELAYED RESTART	10
BYPASS / OUTPUT PHASING	30
PREV. CANCEL SAVE & EXIT	

Alarm Mask

The Alarm Mask sets parameters for all alarms that affect the UPS and output channels. The programmable attributes are described below. The letters L, D, F and E in **Figure 71** refer to these features, allowing the operator to determine their status.

Latching

This option latches the alarm when it occurs. Latching alarms will not automatically clear from the screen when the alarm condition ends, and must be cleared from the screen by the operator.

Dial

When an alarm condition occurs, and the system has an Auto Dial option, the system will dial out to a designated number in accordance with the Dial Out (Auto Dial) instructions set in the UPS. See **AUTO DIAL on page 54** for more information on this feature.

Freeze

This feature will freeze the History Log Buffer(s) if an alarm is detected. This feature is used mainly for diagnostic purpose by Liebert Services and engineering.

Event Logging

The list of alarms that can be masked are shown in **Table 7**. Most Events are automatically logged into the Event History Buffer. Events that can be selected or deselected by the user are:

- Input Line Fail
- Input Under Voltage
- Input Over Voltage
- Bypass Sync Error
- Bypass Voltage Out of Tolerance
- Bypass Line Fail
- Input Contact Alarms (if this option is installed)

Delay

This refers to the time in seconds that must occur before the UPS recognizes an alarm function. The delay can be anywhere from 0 to 99.9 seconds in 0.1 second intervals. If an alarm is set to Latch, it will only recognize the alarm and latch after the delay period.

Figure 71 Alarm / fault name screen

ALARM / FAULT NAME				
ALARM / FAULT NAME	L	D	F	E
BATT. FUSE FAIL	Y	Y	N	Y
BATT. LOW TRANSFER	Y	Y	Y	Y
DC OV TRANSIENT	Y	Y	Y	Y
INPUT PHASE ROT ERROR	N	N	N	Y
RECTIFIER FUSE FAIL	Y	Y	Y	Y
RECTIFIER DRIVE 1 FAIL	Y	Y	Y	Y

UP DOWN SELECT EXIT DESCRIPTION: L - Latching...D - Dial...

The Alarm / Fault Name Screen can be accessed from the Configuration Screen (**Figure 40**) by highlighting Alarm Mask and pressing SELECT.

When the Alarm / Fault Name Screen is displayed, the highlighted alarm will be flashing. (In the figure above, BATT. FUSE FAIL will be flashing.) The DESCRIPTION at the bottom of the screen defines the letters L, D, F, and E. The DESCRIPTION scrolls from right to left, allowing the Operator to see the entire list of features.

The Operator can determine the status of the Latching, Dial, Freeze and Event Log Mask, and change certain attributes by following these steps.



NOTE

When additional navigational choices (UP, DOWN, and SELECT) appear at the bottom of the display screen, the customary rules change slightly.

1. Select the alarm to be viewed.
 - a. To scroll down the list, highlight DOWN on the display screen and press the SELECT button. Continue pressing SELECT until the appropriate alarm is moved to the top position on the screen. Then use the arrow keys to highlight SELECT on the display screen. Press the SELECT navigation button to bring up the Edit screen below.
 - b. To scroll up the list, highlight UP on the display screen and proceed as in a.
2. After editing the first alarm, select the next alarm to be viewed, and proceed as in the steps above.

Figure 72 Alarm edit screen

ALARM / FAULT NAME	BATTERY FUSE FAIL
LATCHING	YES
DIAL	YES
FREEZE	NO
EVENT LOG	YES

SAVE & EXIT
CANCEL

DISCONTINUED PRODUCT

To change the programmable attributes, highlight the attribute to be edited and press the SELECT button. This action brings up a screen allowing the Operator to toggle between YES and NO.

**NOTE**

Some attributes cannot be edited.

AUTO DIAL

The Liebert® Npower™ UPS can automatically dial (through the optional modem) each of two pre-programmed telephone numbers (up to 12 digits) when specified alarm conditions occur within the UPS system.

The Liebert Npower attempts to dial the first number three times at 45 second intervals. If there is no answer, the system rolls over to the second number and repeats the process. If there is no answer on the second number, the system goes back to the first number, repeating the process. The system continues this sequence until connected or disabled.

Upon connection, the system transmits data, in ASCII format, that includes the system identification code, the present alarm message(s) and the time that the alarm(s) occurred. Refer to **3.5 - Communication Interfaces**.

Refer to the Special Functions column in **Table 7 - Alarms, functions, and corrective actions** to see which alarm messages will initiate an auto-dial call.

If the auto-dial numbers were specified at time of order, the numbers are pre-programmed into the system. However, if the numbers need to be changed, follow these steps:

1. From the System Configuration screen, press the Up or Down button to move the highlighted cursor to Auto Dial and press SELECT.
2. The Auto Dial screen will appear. Highlight and select the first Auto Dial Number.
3. Press SELECT to move the arrow to the right.
4. To change a digit, press Up to increase the number or press the Down button to decrease it. Press Select to set the value and move to the next digit.
5. After changes have been made, press SELECT again to return to the System Configuration screen.
6. If required, go to the Second Number screen and enter the correct number.
7. If required, go to the Modem Baud Rate screen and choose from the available baud rates.

Customer Alarm Interface

The Liebert Npower UPS offers a Programmable Relay Board option allowing the Operator to program certain alarms or events to activate single or multiple output relays. (See Section 6 in the Options manual.) In addition to the user-defined programming capability of the system, the Liebert Npower offers two pre-defined relay assignments: AS400, where only the first 3 relay assignments are pre configured (with the other 5 assignments available for user definition, and Standard Set, where the first 7 relays are assigned with the remaining one left unprogrammed. (The 8th assignment is not available for user definition.)

This means that the Operator can choose among the following three configurations for each of the two Programmable Relay Boards.

- AS400
- Standard Set
- User Defined

The default configuration is User Defined.

To access the proper screen for configuring the Programmable Relay Boards:

1. Navigate from the MAIN MENU to the CONFIGURATION screen.
2. From the CONFIGURATION screen, use the arrow keys to highlight CUSTOMER ALARM INTERFACE and press SELECT.

This action will bring up the following screen.

Figure 73 Customer alarm interface screen

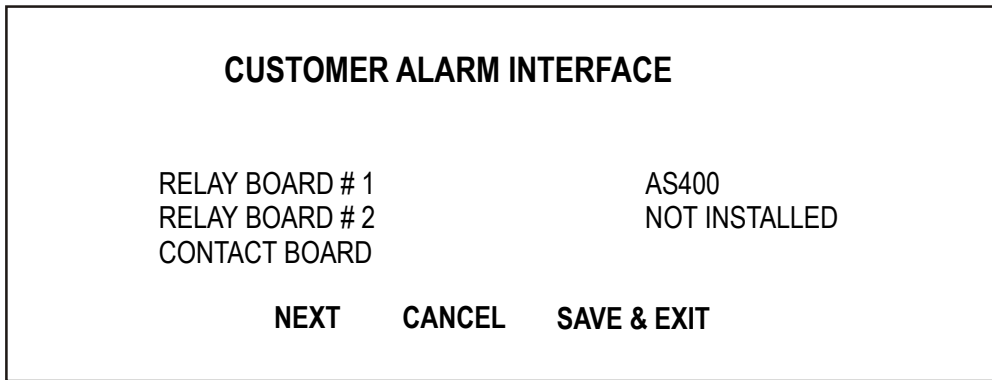

If there is no board, the “NOT INSTALLED” message is displayed.

- Pressing NEXT will bring up the second page.

Figure 74 Customer alarm interface screen, page 2

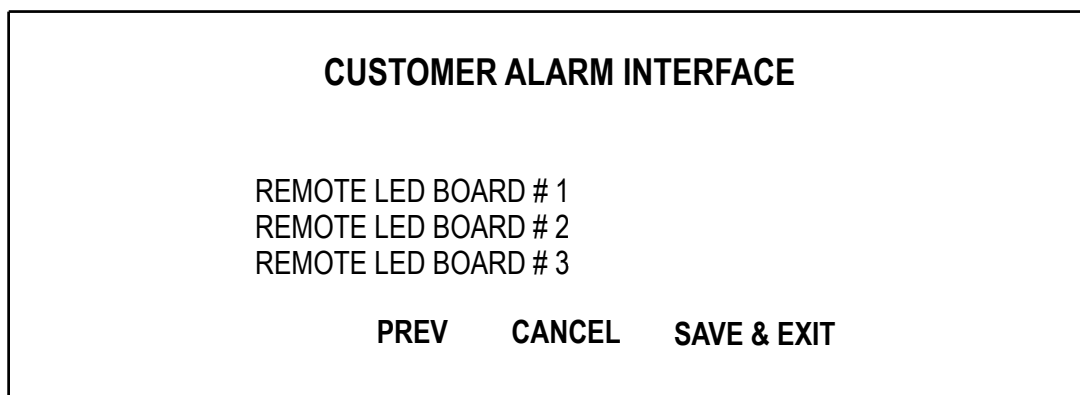

To access the Programmable Relay Board #1, highlight RELAY BOARD #1 from the first page of the CUSTOMER ALARM INTERFACE screen and press SELECT to bring up the following screen.

Figure 75 Programmable output relay board #1, AS400 assignment

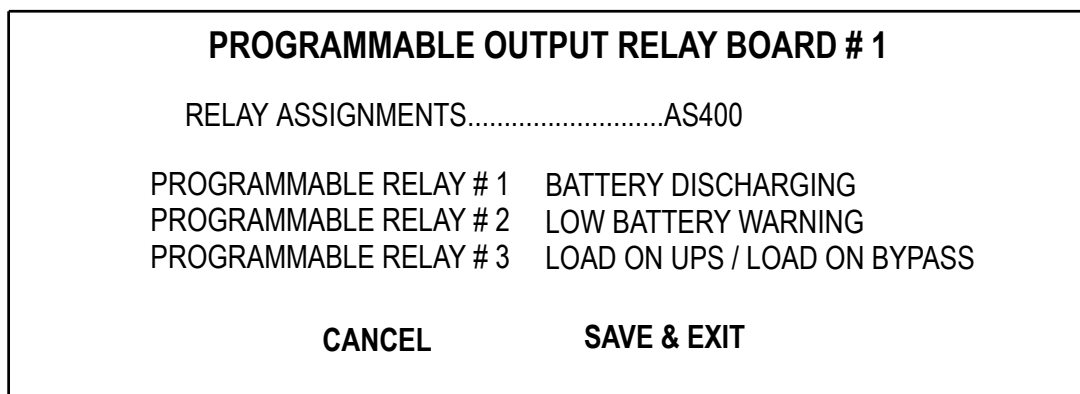

The AS400 pre-assigned relays are shown in this screen.

To change the relay assignment, select RELAY ASSIGNMENTS from the screen and press SELECT. The following screen will appear.

Figure 76 Relay assignments

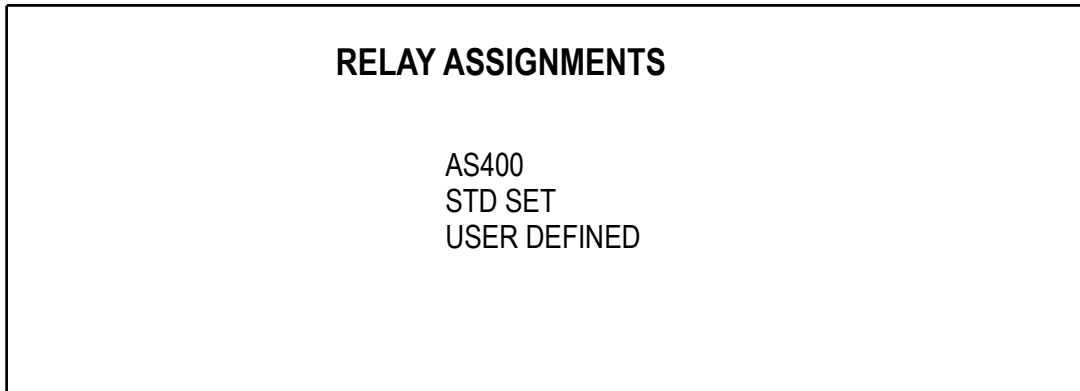

If you select STD SET, the following screen will be displayed.

Figure 77 Programmable output relay board, standard set

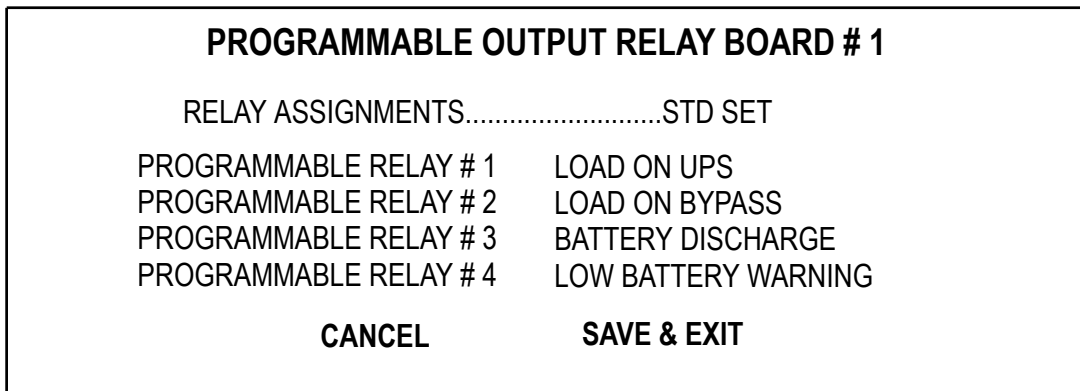
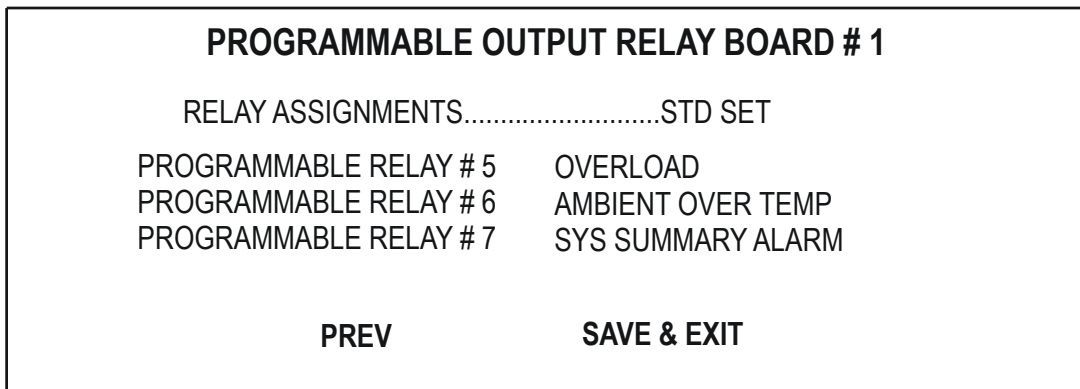

Figure 78 Programmable output relay board, standard set, page 2



DISCONTINUED
PRODUCT

If the Operator selects USER DEFINED from the RELAY ASSIGNMENTS screen, the following screen will come up.

Figure 79 Programmable output relay board, user defined

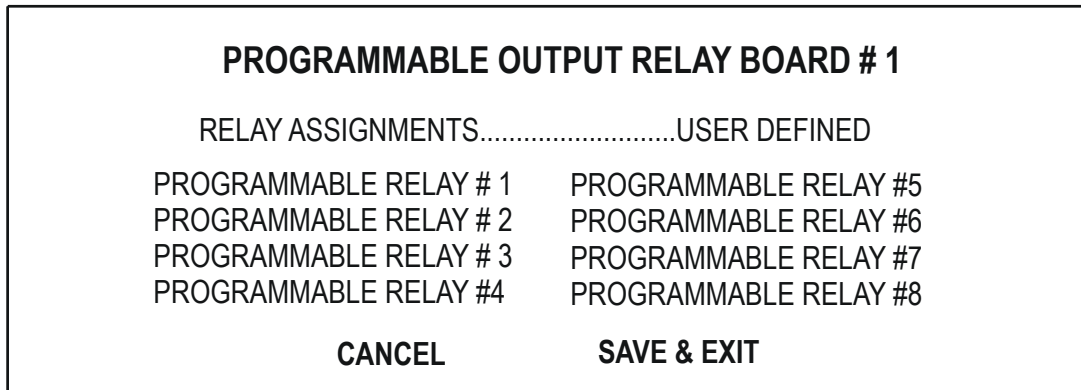

All User Defined relays are programmable.



NOTE

Alarms have a separately programmable function that allows them to be latching or non-latching. If the alarm is latched, then the programmable relay will also latch until the alarm is reset.

To begin programming the User Defined Relays, highlight the relay to be programmed and press the SELECT button. This action will bring up the List of Alarms/Faults screen. (Figure 80). Initially, the box beneath the relay will be empty.

To attach an alarm to each relay, follow the steps under **Navigating Protocol on page 58**.



CAUTION

Navigating through screens with additional navigational selections at the bottom of the display screen is slightly different from navigation involving only the navigation buttons below the display screen. Specific instruction is given below.

Figure 80 List of alarm faults screen

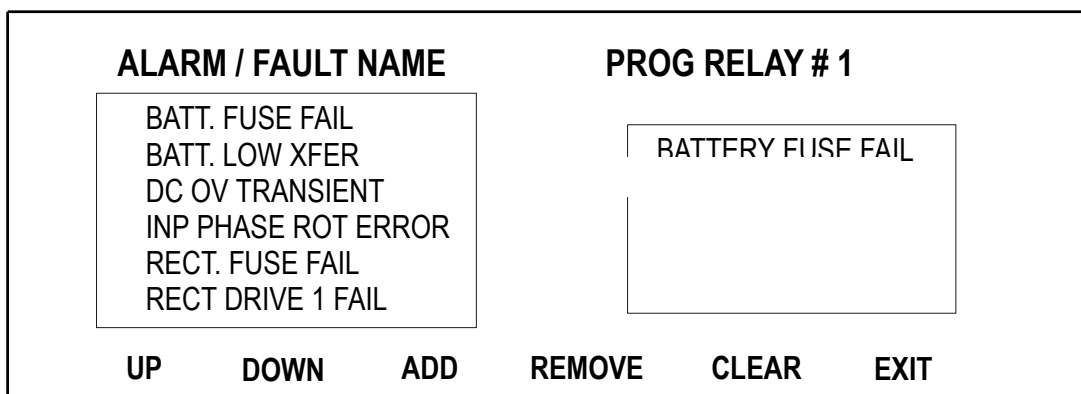

The alarm at the top of the screen will be flashing.



NOTE

If the Liebert® Npower™ has Open Comms-Discrete Inputs (Input Contact Isolators, Section 7 of the Options Manual, these will show up on the alarm list and can be selected to connect to a programmable output relay.

DISCONTINUED PRODUCT

Navigating Protocol

For the screen above and others like it, the normal screen navigation rules are changed. It is important to differentiate between the selections at the bottom of the display screen (UP/DOWN/ADD/REMOVE/CLEAR/EXIT) and the navigation buttons or arrow keys below the display screen. To scroll up the Alarm/Fault list, use the arrow keys to highlight the UP selection at the bottom of the display screen. Next, press the SELECT navigation button. Continue this sequence until you have positioned the proper Alarm/Fault in the active position at the top of the list. To scroll down the list, use the arrow key to highlight the DOWN selection at the bottom of the display screen. Next, press the SELECT navigation. Continue until the proper alarm is positioned at the top of the list.

When the selected Alarm/Fault is in the active position at the top of the list, it will be flashing. To attach this alarm to a Programmable Relay, use the arrow keys to highlight ADD at the bottom of the display screen. Press SELECT and your selection will now appear in the right hand box.

You may attach up to four alarms to each relay by following this procedure. Since there are almost 200 alarms, it is advised that you review the entire list and note which alarms you want connected to each relay before beginning your selections. Keep in mind that if you attach more than 1 alarm to the relay, and the relay is triggered, you will not be advised which of the alarms is activated. You may be able to determine this through other diagnostic features of the Liebert® Npower™, but it will not be evident from this feature.

If you decide to remove an alarm from the selected alarm set, scroll the list to put the alarm you want to remove in the top (flashing) position on the ALARM/FAULT NAME list. Use the arrow keys to move the cursor to REMOVE. Press SELECT to remove the alarm from the right hand (connected) list.

If you wish to clear all the alarms and start over, move the cursor to CLEAR and press SELECT.

After you have selected the alarms you want connected to PROG RELAY #1 use the arrow keys to move the cursor to EXIT, press SELECT. This will put you back to the PROGRAMMABLE OUTPUT RELAY BOARD # 1 screen. Follow the procedure above to program the next relay. When all of the relays you wish to program have been completed, highlight SAVE & EXIT and press SELECT.



CAUTION

You must select save & exit from the programmable output relay board screen or your selections will not be saved.

If you have a second relay board installed, from the CUSTOMER ALARM INTERFACE screen, repeat the same procedures for RELAY BOARD # 2.

3.3.6 Manual Transfer

The Manual Transfer screen allows the Operator to transfer the critical load to and from bypass through the static bypass switch. This screen can only be accessed when the rotary switch is on Normal position. To access the screen, start at the MAIN MENU. Highlight MANUAL TRANSFER and press SELECT. There are 3 status options for the Inverter: In sync, lag x degrees, and lead x degrees.

The message Retransfer to UPS or Transfer to Bypass will appear depending on status of the critical load. The Operator can proceed with the transfer/retransfer by highlighting OK and pressing SELECT or EXIT. If a transfer or retransfer is not allowed, the FLASHING message Transfer Not Allowed is displayed and the only option is to Exit. If the Operator chooses to Exit, the screen returns to the Main Menu.

Figure 81 Manual transfer / retransfer screen when transfer is allowed

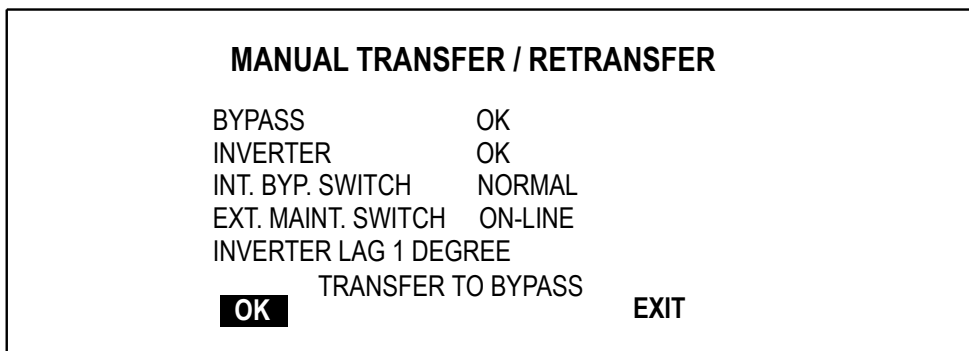
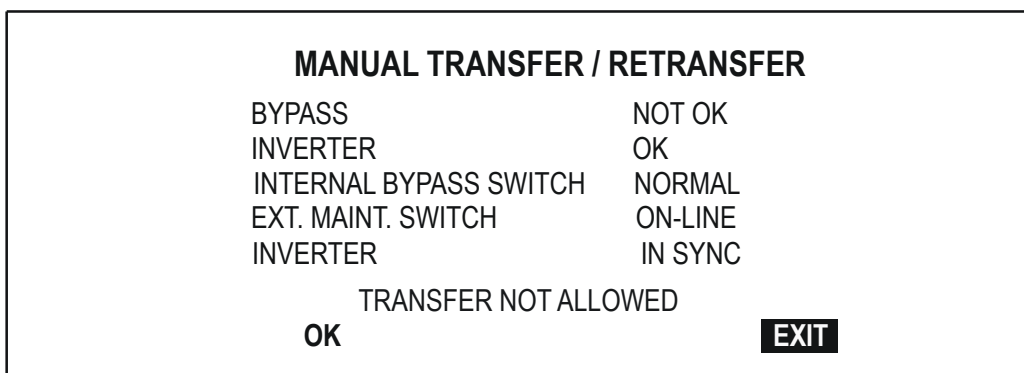

Figure 82 Manual transfer / retransfer screen when transfer is not allowed



In the figure above, the message “TRANSFER NOT ALLOWED” will be flashing.

3.3.7 Battery Management

The Battery Management screens display information on battery self tests, battery equalization, battery temperature, and battery cycle monitoring. This information enables the operator to immediately see the effects of load shedding on time remaining and to accurately assess remaining power resources. The Battery Management screen is accessed from the Main Menu.

Figure 83 Battery management screen

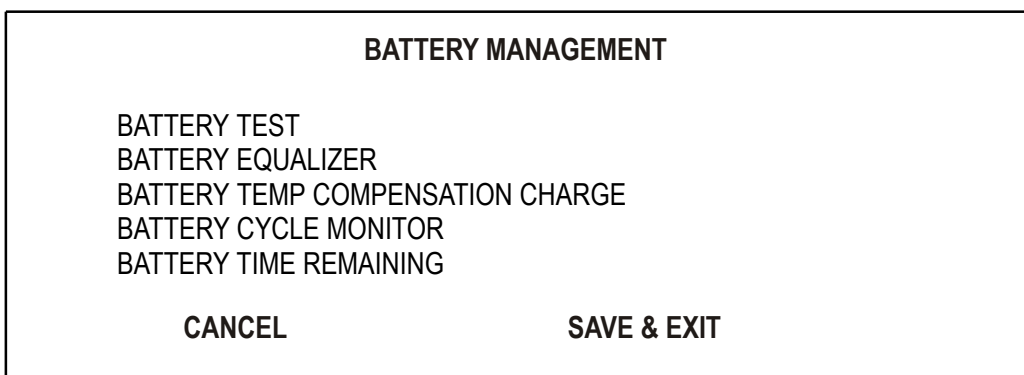

Battery Test

The Battery Test screen allows the Operator to select between Auto Test and Manual Test.

DISCONTINUED PRODUCT

Figure 84 Battery test screen

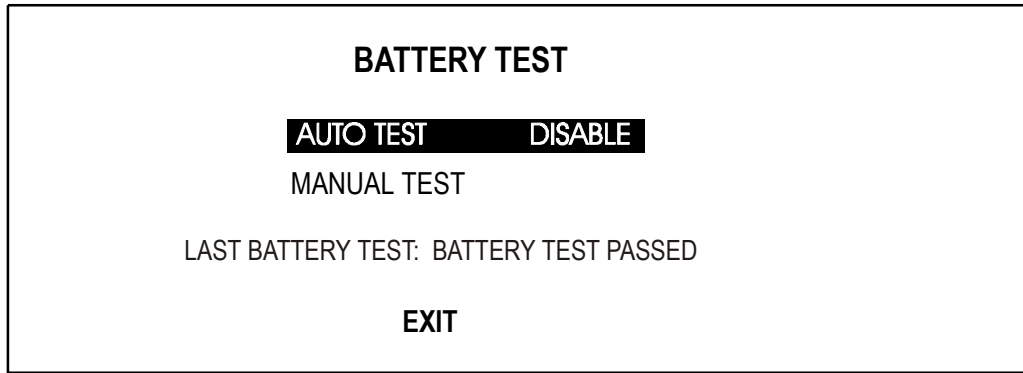

The auto battery self test can be enabled / disabled from the Battery Test Screen. It is performed unattended by programming Time, Date, Test Cycle and Test Duration in Battery Self Test Screen. Selecting MANUAL TEST from the Battery Test screen will perform an Operator-initiated test.

The following conditions and features apply to either Auto or Manual Mode:

- If you go to the battery screen, it will indicate “Battery Test in Progress”. When the test is complete, the indication “Last Battery Test” will either say “Battery Test Passed” or “Battery Test Failed.”
- One of two alarms are logged in the event log screen: “Battery Test Passed” or “Battery Test Failed”. If failed, there will be accompanying alarm messages in the event log to describe the reason for failure. (i.e. Battery Recharging). “Battery Test Failed” message is also latched in the active alarm/fault window of the Mimic screen.
- There are a number of pre-conditions which must exist before it is possible to start a battery test:
 - The Battery CB, Input and Output contactors must all be closed.
 - All phases of Input and Bypass volts must be within defined limits of 80% to 115%.
 - Battery Charge must be greater than 90%.
 - The test is interlocked to “Batt Ov Temp Warning” alarm. When this alarm is present, battery test won’t start.
 - DC volts must be greater than the DC Bus Float Voltage of 540 VDC.
 - A load must be greater than 15% of rated kVA.
 - The On Generator status must be False.
 - Input frequency must be within limits.
 - Auto and Manual tests are interlocked; only one can be active at a time.
- The recommended default time settings based on the battery size are shown in the table below.

Table 5 Default time settings

Battery Type	Test Duration
15 Minute	1 Minute
30 Minute	2 Minutes
45 Minute	3 Minutes
60 Minute	4 Minutes
75 Minute	5 Minutes
90 Minute	6 Minutes

The factory default setting is 60 seconds and can be set between 30 to 900 seconds.

The test starts by commanding the rectifier control circuit to lower the Rectifier output voltage. The rectifier stays on, but is phased back. This means the Rectifier is still available to support the load if the battery fails.

DISCONTINUED PRODUCT

A battery test will be aborted if any of the following become true:

- The battery Over-Temperature Warning becomes active.
- Battery CB, Input or Output contactors open.
- Any phase of the Bypass or Input volts exceeds the limit of 80% and 115%.
- If the battery voltage falls too quickly during the test.

Figure 85 Automatic test screen

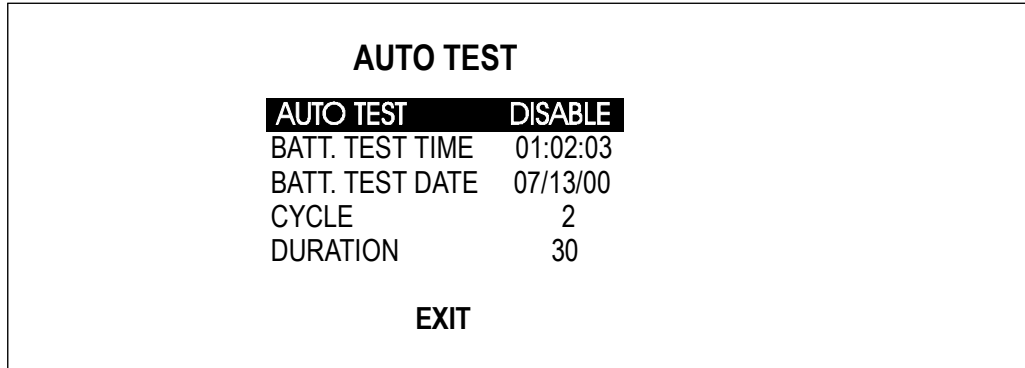

To enable the Auto Battery Self Test, Select “Auto Test Enable” from the Battery Test screen. Next, set the Date and Time at which the first test will be performed. Set the Test Cycle period in weeks. (The range is 2-9 weeks and the default is 2 weeks.) Finally, set the Test Duration time in seconds according to the table above. The range is 30-900 seconds and the default is 60 seconds. Use the UP DOWN navigation buttons to change the cursor position when setting battery parameters.

Figure 86 Set battery cycle screen

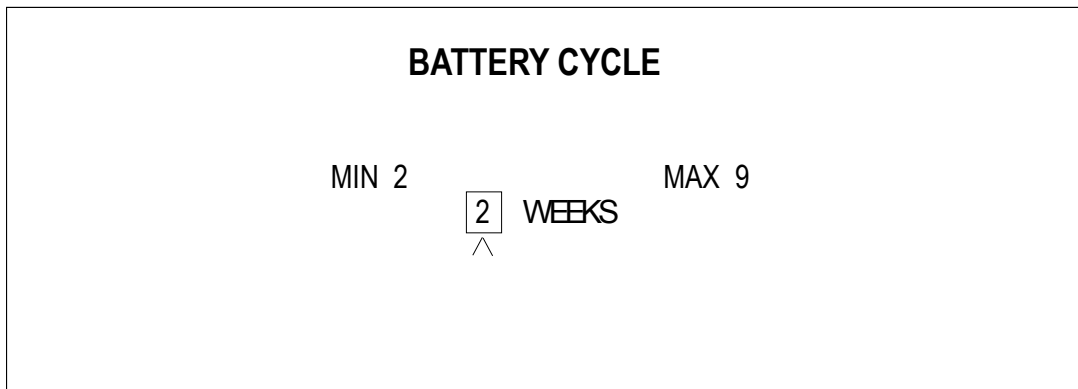
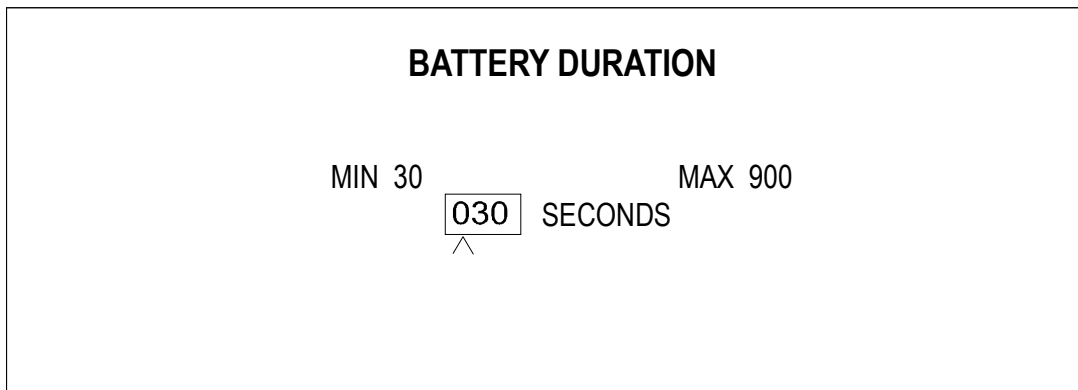

Figure 87 Set battery duration screen



DISCONTINUED
PRODUCT

Battery Equalizer

In order to prolong battery life, the Liebert® Npower™ system provides a User-programmable setting after each battery discharge. The equalize setpoint is typically set to a higher float voltage.

When the input utility power is interrupted, the battery supplies DC power to the inverter so there is no interruption of power to the critical load. When the AC input power is restored, the battery equalize recharging circuit can be activated automatically or manually to increase the rectifier/charger output voltage to recharge the battery. The battery equalize circuit may also be manually activated at any time during normal float (constant) voltage operation. The equalizing time can be adjusted from 0 to 72 hours. The default setting is 0. A setting of 0 is interpreted as if the feature were disabled.

The Battery Equalize screen The battery equalize screen lets the operator change the battery equalize recharging mode from manual to automatic, and to observe or change the equalize time. To access this screen go to the MAIN MENU, highlight BATTERY MANAGEMENT, and press SELECT. This brings up the Battery Management screen. Highlight BATTERY EQUALIZER and press SELECT. The Battery Equalizer Screen (**Figure 88**) will appear.



CAUTION

The manufacturers of the valve-regulated batteries supplied with Liebert's standard battery cabinets recommend that when first installed the batteries be equalize charged. After that initial equalize charge, they recommend no further equalize charging for their batteries.

Other manufacturers may have different recommendations for their products. Consult the battery manufacturer's manual for specific information about equalize charging.

Figure 88 Battery equalizer screen

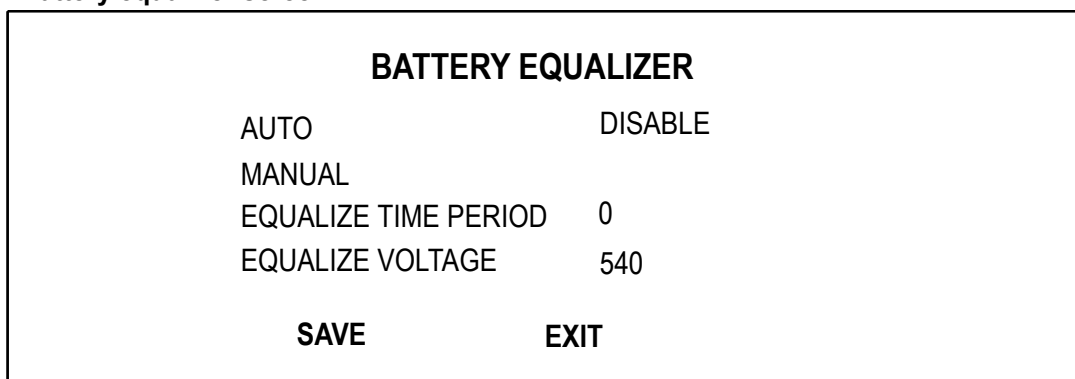

From the Battery Equalizer Screen, you can choose one of the four options on the screen. The screens for these options are illustrated below.

Figure 89 Auto screen

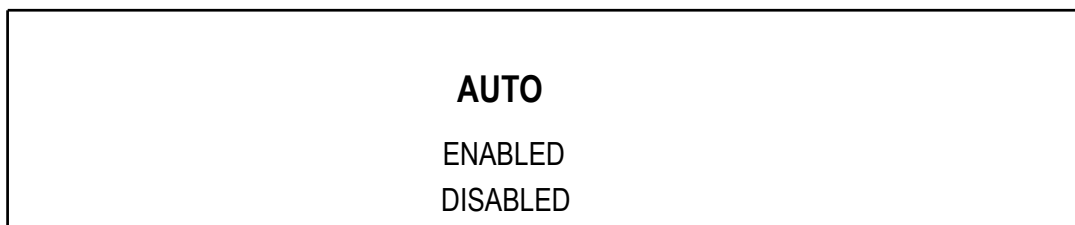

AUTO MODE—When the battery recharge control logic is in the AUTO MODE, the UPS battery charger attempts the equalization process only if the EQUALIZE TIME PERIOD is greater than zero, the battery voltage has been at or below the Battery Discharging alarm limit for longer than 30 seconds, and the battery breaker (MBD) is closed.

MANUAL MODE. This mode enables the operator to manually initiate a battery equalize charge to raise the DC bus voltage to correct a non-uniformity in the individual cell voltages or specific gravity readings.

Figure 90 Manual screen

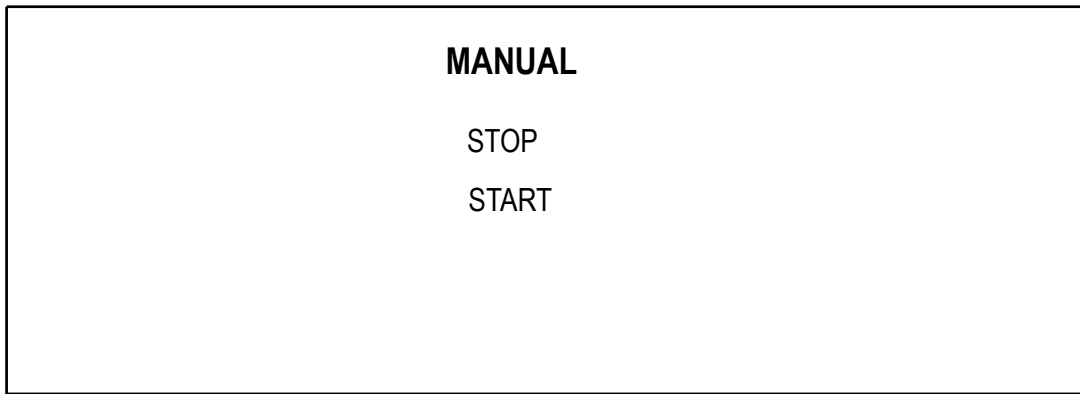

STOP EQUALIZE CHARGE—This selection lets the operator halt the equalizing charge to the battery at any time, whether the circuit was activated automatically or manually.

EQUALIZE TIME PERIOD. This selection permits the Operator to adjust the battery equalize time in one hour increments from 0 to 72. The battery equalize time must be greater than zero for the battery to begin recharging in both the AUTO and the MANUAL modes. Use Up/Down buttons to set battery equalize time and press SELECT.

Figure 91 Equalize time period screen

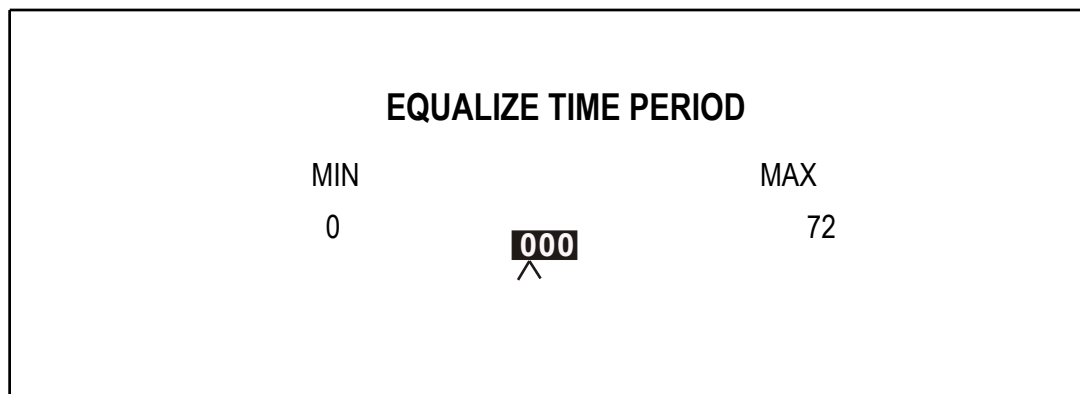

When the battery is at full voltage (not being recharged), this selection reads EQUALIZE TIME PERIOD (hrs). When the battery is recharging, this selection reads EQUALIZE TIME REMAINING (hrs). After the equalize recharge time has expired, the indication returns to the preset equalize time.

Figure 92 Equalize voltage screen

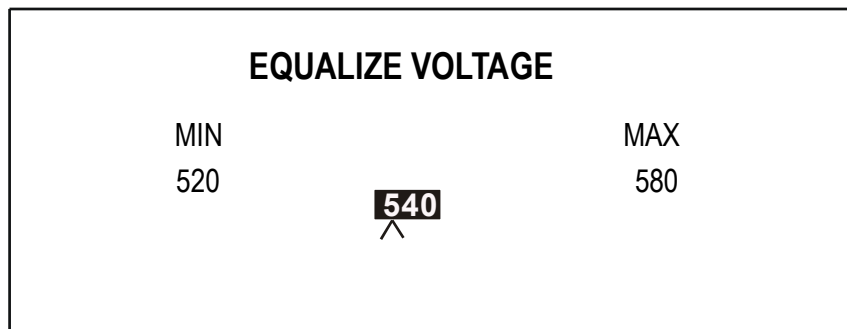

The equalize voltage is also programmable. In the example above, the range is 520 to 580 volts with the default being 540 volts.

DISCONTINUED
PRODUCT

Battery Temperature Compensation Charge

The Battery Temperature Compensation Charge screen is accessed from the Battery Management Screen (**Figure 83**). The Operator can enable or disable Battery Temp Compensation function. He can also change the compensation setting by going into the edit screen. The values are in millivolts/degree C.

Figure 93 Battery temperature compensation charge screen

BATTERY TEMP COMPENSATION CHARGE			
BATTERY	TEMP.	COMPENSATION	ENABLED
15 C = <	TEMPERATURE	< 20 C	850
20 C = <	TEMPERATURE	< 25 C	1000
25 C = <	TEMPERATURE	< 30 C	1000
30 C = <	TEMPERATURE	< 35 C	850
[NEXT]		EXIT	

To enable or disable the Battery Temperature Charge, highlight the top line in the screen above and press the SELECT button. This will bring up the following screen.

Figure 94 Battery temperature compensation enable/disable screen

BATTERY TEMP COMPENSATION	
ENABLE	
DISABLE	

To access page 2 of the Battery Temp Compensation Charge Screen, press NEXT on the Battery Temp Compensation Charge Screen (see **Figure 93**).

Figure 95 Battery temperature compensation charge screen, page 2

BATTERY TEMP COMPENSATION CHARGE			
35 C = <	TEMPERATURE	< 40 C	800
40 C = <	TEMPERATURE	< 45 C	750
PREV		[EXIT]	

To edit the Battery Temperature Compensation, select the second line from the top in **Figure 93** and press the SELECT button. The following screen will come up.

DISCONTINUED PRODUCT

Figure 96 Battery temp compensation edit screen

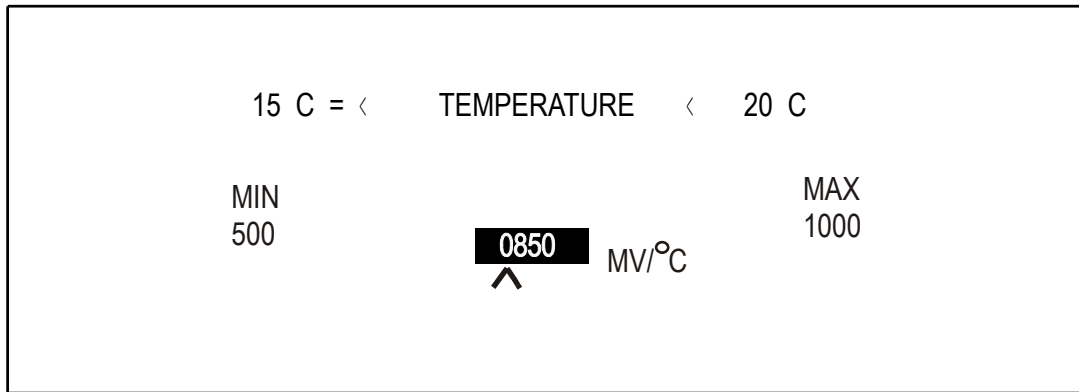

Battery Cycle Monitor

The Battery Cycle Monitor feature provides detailed data each time the batteries experience a discharge event. By keeping track of cycles imposed on the battery, the Operator has an indication of consumption, amount of useful life left on the batteries, and an early warning to service and/or replace the batteries. The data can be retrieved from the front panel LCD, remote terminal interface, or a modem connection.

The Battery Cycle Monitor screen can be selected from the Battery Management screen (See Figure 83). The default setting is set to ENABLE.

Figure 97 Battery cycle monitor screen

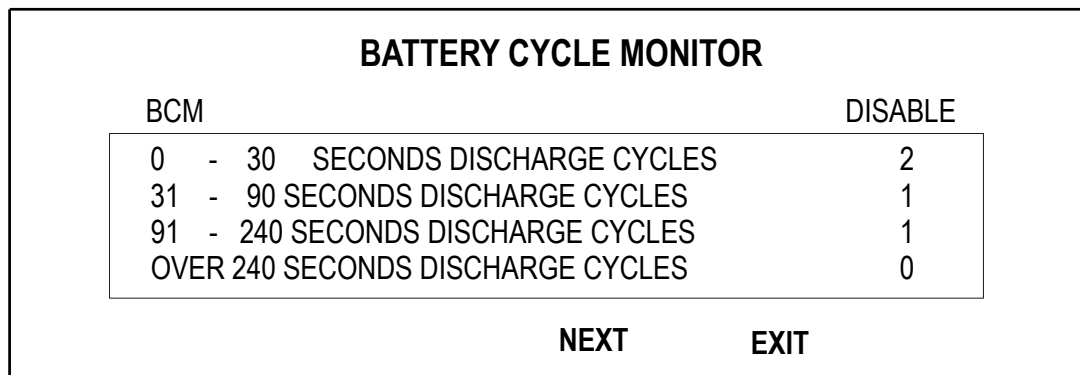

The second page, accessed by selecting NEXT (See Figure 98), allows the Operator to view the Summary Page and to erase the BCM time bucket data permanently from the non-volatile storage. (This action requires the system password.) The Operator can also erase the summary information as well, providing he inputs the proper password. However, this is not recommended for anyone except factory technicians or Liebert® Service engineers.

DISCONTINUED PRODUCT

Figure 98 Battery cycle monitor screen, page 2

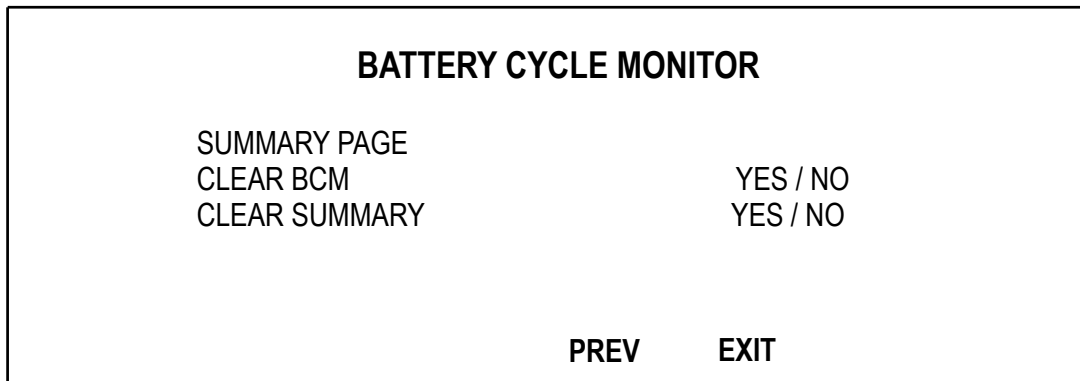

DISCHARGE CYCLES

The Discharge Cycles Screens are accessed from the Battery Cycle Monitor Screen.

Each of the four buckets will have a format as illustrated in **Figure 99** showing the 0-30 seconds discharge cycles. The ID numbers are stamped in the order of occurrence.

For example, assume that the following four discharge cycles have occurred:

- 1 - On 03/09/01, there was discharge cycle that lasted 25 seconds.
- 2 - On 04/12/01, there was discharge cycle that lasted 96 seconds.
- 3 - On 04/25/01, there was discharge cycle that lasted 42 seconds.
- 4 - On 04/26/01, there was discharge cycle that lasted 21 seconds.

The 0-30 bucket should display event IDs 1 and 4, with #4 shown as the most recent discharge event. The 31-90 bucket displays event #3, and the 91-240 bucket displays event #2.

The maximum field length for seconds is 99999 (5 digits) which equates to 27.78 hours. DC Bus volts has xxx (3 digits).

FORMAT—Maximum discharge 1 is displayed in xx.x format (i.e. 65.5, 99.9 max) when the discharge current is 6553 (unsigned integer / 10) for each cycle. The field length for KWH is 5. When less than 1000 KWH, it is displayed in xxx.x format (i.e. 340.8, 999.9 max). If it exceeds 999.9, the decimal point is removed and the format becomes xxxxx. The maximum displayed KWH is 6553 for each cycle. The displayed range for battery temperature that can be displayed is from 0 to 126°C (product specifications call for the operating range of 0-40°C.) Any readings outside that range will be displayed as *.

To view the complete list in the event, use the UP and DOWN selections to scroll the page up or down. Selecting the TIME button will display the time stamp of each cycle for three seconds after which it repaints the column with DATE stamps again.

Figure 99 0-30 seconds discharge cycles

0 - 30 SECONDS DISCHARGE CYCLES						
#	DATE	SEC	MIN-DC	MAX-A	KWH	C
4	04/26/01	21	443	100	1	25
1	02/09/01	25	439	89	1	24
	TIME	DOWN	UP	EXIT		

SUMMARY PAGE LAYOUT

The Summary Page Screen is accessed from the Battery Cycle Monitor Screen.

DISCONTINUED PRODUCT

The BCM summary page includes the following information:

Accumulated number of all discharge cycles.

Accumulated or active time on battery.

Accumulated or active battery AMP hours.

Accumulated or active battery KW hours.

The upper range of all the accumulated numbers is kept in two long integers to make certain they don't overflow.

Figure 100 Summary page screen

SUMMARY PAGE	
ACCUMULATED NUMBER OF CYCLES	4
ACCUMULATED BATTERY TIME (SEC)	184
ACCUMULATED BATTERY AMP HOURS	6
ACCUMULATED BATTERY KW HOURS	3
EXIT	

DISCHARGE CYCLE DETECTION / RE-ARMING METHOD

A battery discharge cycle starts with the reversal of battery current (discharge AMPS). The discharge current has to be greater than 2% of battery discharge rating. The cycle is terminated and re-armed (reset conditions for next cycle) when battery current enters the Normal operating range of +/- 1%. The normal range is displayed as NORM in the battery section of the one-line Mimic screen. When battery current exceeds 1% in the positive direction, the displayed status is changed to CHG (charge) and when drops in the negative direction by more than 1%, it is displayed as DIS (discharge). Battery AMPS resolution is 0.1.

When an End of Discharge condition occurs (fault "BATT LOW TRANSFER"), the cycle is terminated, cycle and summary data saved, and the cycle is re-armed. The same thing happens in the event of a loss of communications with UPSC (alarm UPSC-MM COMM FAIL.") After approximately 10 seconds, the BCM is re-armed for the next cycle.

BCM DATA DEFINITIONS / STORAGE

At the start of every discharge cycle, Time and Date are recorded along with Battery Compartment Temperature in degrees C. While the cycle is in progress, the following data are stored: Lowest DC Bus Voltage, Battery KW Hours, and Highest Battery Discharge AMPS. At the end of the cycle, all of these parameters including Cycle Duration (in seconds), and Summary data including Accumulated Number Of Cycles, Accumulated Battery Amp Hours, and Accumulated Battery KW hours are stored.

A total of 132 cycles are saved in a circular buffer.

BCM ALARM NOTIFICATION

When the number of cycles exceeds 128, an alarm message will be displayed to alert the user (local and remote) that the end of buffer is near. The alarm message is defined as "BATT CYCLE BUFFER FULL". The alarm is kept active for a minimum of 30 seconds to allow the software to download the 128 cycles to the terminal port and also dial out with this alarm, providing the modem option is installed and enabled. The cycle storage continues to 132. The 133rd event will override the first event in the buffer. But the previous cycles will not be destroyed until overwritten with future BMC cycle data.

REMOTE MONITORING

The information within each of the time buckets and summary status page can be retrieved via the Terminal and Modem ports.

See 3.5.1 - RS-232 Port: Local Reporting Terminal for a list of commands used to retrieve Service Terminal Information.

Battery Time Low Warning

The Battery Time Low Warning Feature alerts the Operator to the battery time remaining in minutes. The Operator can set the warning time by navigating from the CONFIGURATION Screen to USER SETTINGS, Page 2. This screen is illustrated below.

Figure 101 User settings, page 2

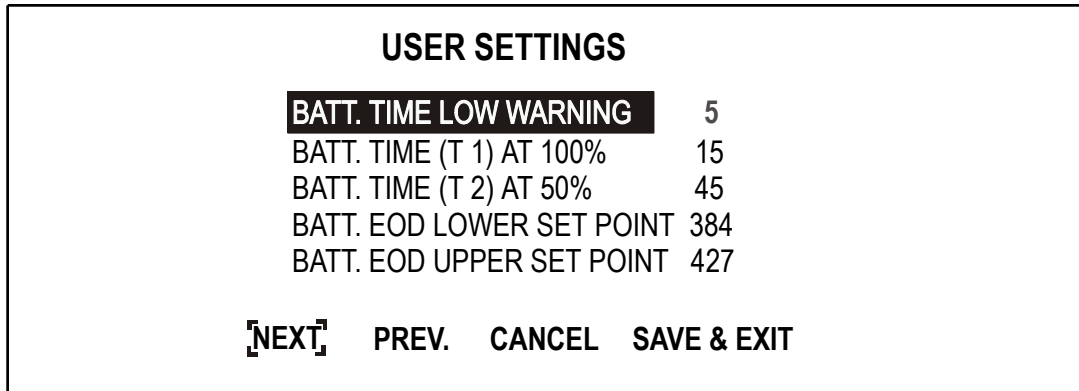

Highlight BATT TIME LOW WARNING and press SELECT to bring up the following password-protected screen.

Figure 102 Battery time low warning screen.

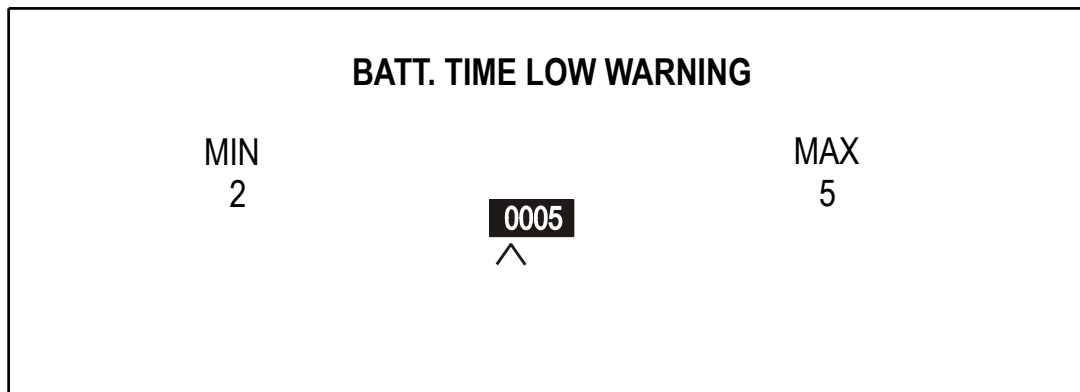

NOTE

The default setting is 5. The maximum limit changes according to the number of battery cabinets, and the time rating of each. For a single battery, the upper limit is T1. For more than one battery, the upper limit is approximately equal to the total battery time.

After setting the time, press SELECT to save the changes and return to the previous screen.

Battery Supplement

This feature allows the UPS to continue to supply power to the output from both the rectifier and the battery when the input voltage sags. This mode of operation will keep conditioned-uninterruptible power at the output for a longer period of time as compared to just turning off the rectifier when the input voltage sags.

The feature is permanently enabled at the present time, and can be identified by an alarm reading “Battery Supplement Active”. The alarm will clear when the Input Undervoltage alarm clears and/or if the rectifier turns off and/or if the Battery Discharge alarm clears. There will be 1-second delay before setting or clearing this alarm.

DISCONTINUED PRODUCT

3.3.8 Auto Restart

The Auto Restart feature allows the UPS to restart without operator intervention after shutting down due to loss of input power. When the utility is restored, this feature directs an automatic restart, delivering the load power through the inverter, connecting the batteries to the DC bus, and recharging the batteries. To utilize this feature, your system must have Liebert® motorized Battery Breakers on each battery cabinet.

The first step is to enable the Auto Restart feature. From the Configuration Screen, select System Settings, and then Options. From the Options Screen, select Auto Restart and select YES. (The factory default is set to NO.) This option is password protected.

After enabling the Auto Restart feature, proceed to the Auto Restart Setting screen. From this screen, the Operator can set the restart to System (the default is Disabled), and program a source qualification timer. To access this screen, navigate to Configuration, and then to User Settings. Select Auto Restart.

The following screen will come up.

Figure 103 Auto restart setting screen

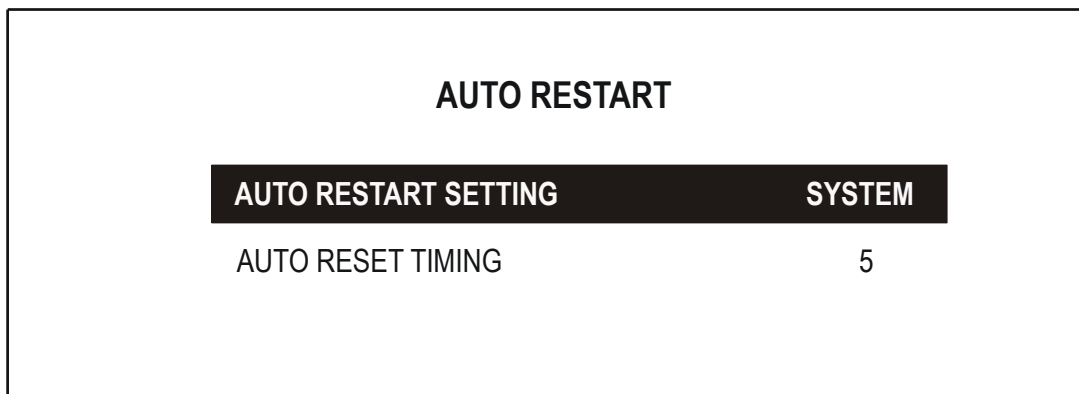

The source qualification timer dictates how long to allow for input and bypass voltages to return to their nominal limits. The default value is 100 with a programmable range of 5-100 minutes. Since a setting of 100 signifies an infinite wait time, the finite range can be set between 5 and 99 minutes. Normally, 5 minutes is adequate.

Setting the Auto Restart to SYSTEM, automatically changes the setting for Motorized Battery Breaker to “Motorized”. The battery type setting cannot be changed back to Manual once Auto Restart is set to YES. However, if Auto Restart Option is Disabled (Set to NO), battery type can be independently set to Motorized. To access the proper screen, navigate to Configuration, then System Settings, then Options, then Motorized Battery Breaker, and select Motorized.

Once in Auto Restart mode, a new screen will report the progress. (See Figure 104).

Figure 104 Auto restart screen layout

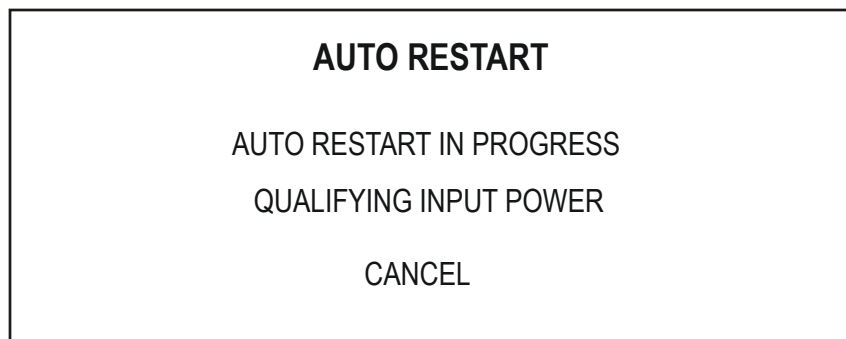

DISCONTINUED PRODUCT

The message, AUTO RESTART IN PROGRESS will be displayed during the Auto Restart sequence. The text line below this message signifies the condition being checked, and flashes in reverse video while the message is displayed.

The Operator can cancel the Auto Restart operation by selecting and acknowledging CANCEL. When this is done, a message will appear asking, “Canceling will abort Auto Restart operation. Are you sure you want to cancel? The Operator can then select YES or NO”.

Alarm Notifications

At the start of Auto Restart operations, an alarm condition is recorded to log “Auto Restart Initiated”. If during the process Auto Restart is halted as a result of failed condition, a subsequent alarm is recorded as “Auto Restart Failed”. This will be a latched alarm and must be acknowledged and reset by the Operator. See **Alarm Messages on page 76** for a complete description of these alarms.

Auto Restart Trigger Condition

Any time the UPS detects and records an EOD (End of Discharge) condition occurring at the same time the input contactor is open, it recognizes that the batteries can no longer support the load. This scenario sets the Auto Restart flag, initiating the Auto Restart sequence.

In a Dual Input system, both Input and Bypass must be available to enable Auto Restart.

3.3.9 System Status Monitoring

In addition to the standard UPS metering and alarm information, Liebert® Npower™ monitors and calculates other relevant data. This data can be accessed by starting from the Main Menu, selecting Status Reports, then System Status.

The counters start from the time Liebert Services or in special cases the contractor complete the startup procedure and customer accepts the system. Once the unit is accepted, Liebert Services will go to the System Status screen and complete the sign off procedure. This is a password-protected screen. Once the sign off procedure is completed (easy to follow on screen prompt messages), the software will record the Real Time Clock’s time and date. The sign off screen will no longer be displayed in any subsequent entries in System Status screen. Only the Date and Time of system sign off will be shown as reference. All future data gathering will start from this date and time.

The System Status Screens contain the following data which is updated real time:

- Accumulated Installed Hours
- Accumulated Operating Hours on UPS
- Accumulated Operating Hours on Bypass
- Accumulated Backup Minutes
- Accumulated # of Brown Outs
- Accumulated # of Black Outs
- Accumulated # of Manual Transfers
- Accumulated # of Manual Retransfers
- Accumulated # of All Transfers
- Accumulated # of All Retransfer
- Accumulated # of Overload Conditions
- Accumulated # of Unsuccessful Auto Retransfers
- Average Load%

Figure 105 System status screen

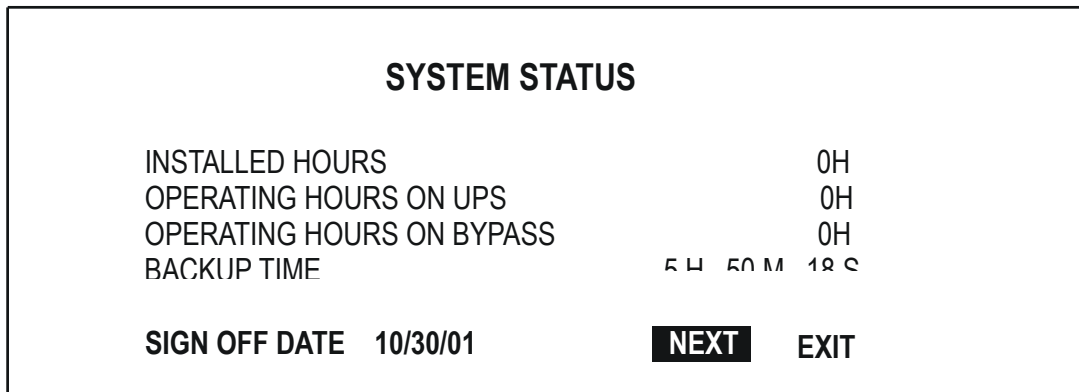

The Sign Off Date segues to Sign Off Time and back every 5 seconds.

Figure 106 System status screen, page 2

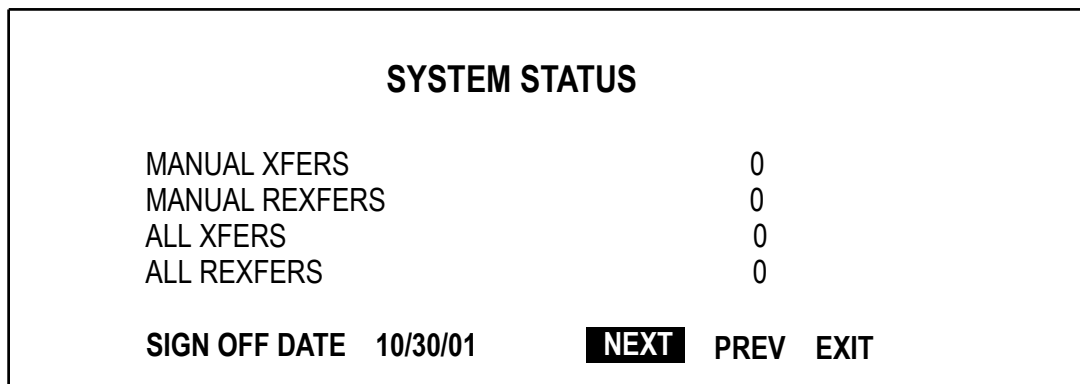
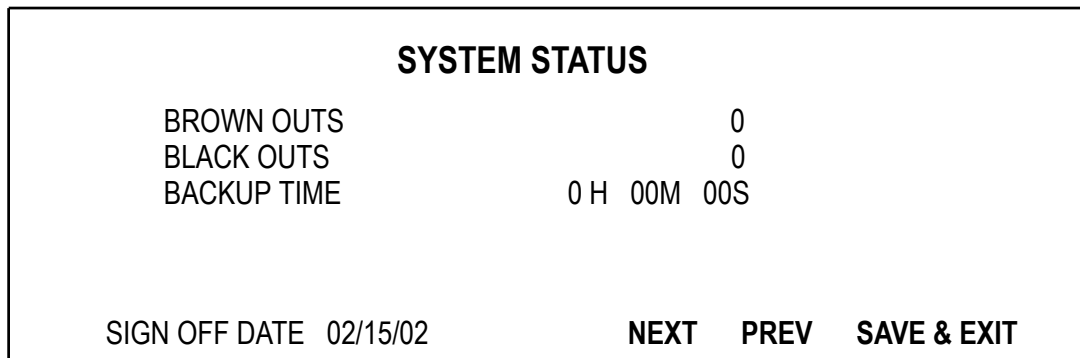

Figure 107 System status screen, page 3



A brownout occurs when an Input Undervoltage condition exists for more than 5 minutes. During this time, Input Line Fail condition is not active. To determine the brown out count, highlight BROWN OUTS and press SELECT. Once a count is made, allow 30 minutes to re-arm the counter.

The condition for blackout occurs any time all 3 phases of the input voltage sources falls below 60% of the rated input voltage rating. The counter starts from the time the Liebert® Services completes the startup procedure, and signs off the SYSTEM STATUS Screen. The counter is automatically re-enabled when all 3 phases of the input voltage source rise above the 60% limit.

The Accumulated Number Of Blackouts (Blackout Counter) can be viewed by highlighting BLACK OUTS and pressing SELECT.

DISCONTINUED PRODUCT

Figure 108 System status screen, page 4

SYSTEM STATUS	
AVERAGE LOAD	74%
OVERLOAD CONDITIONS	0
UNSUCCESSFUL AUTO REXFERS	1
AUX TEMP	
SIGN OFF DATE 10/30/02	PREV EXIT

STATUS DEFINITIONS AND CONDITIONS

Accumulated Installed Hours

Once the “UPS Sign Off” is acknowledged, it is stamped with RTC time and date. This step must be performed by Liebert Services personnel. The software will keep track of the elapsed hours from that point on by subtracting the current time and date from the sign off time and date.

Accumulated Operating Hours on UPS

With output contactor closed and load KVA greater than 1%, software accumulates operating hours that the load is supported by UPS.

Accumulated Operating Hours on Bypass

With bypass contactor closed and load KVA greater than 1%, software accumulates operating hours that the load is supported by Bypass.

Accumulated Backup Hours

With Battery breaker closed and battery discharge current greater than 2% rated (I_{batt}), software accumulates Hours or fraction of hours (i.e. 0.2, 1.9) that the load is supported by the battery system.
 $I_{batt} > 0.02 \text{ (Rated KW)}/0.96/V_{batt}$

Accumulated # of Brown Outs

An “Input Undervoltage” condition must exist for more than 5 minutes. During this time “Input Line Fail” condition must not be active. Once a count is made, allow 30 minutes to re-arm the counter.

Accumulated # of Manual Transfers

User initiated and successful transfers to bypass commanded from the manual transfer screen. MM checks the status of output and SBS contactors to verify a transfer has successfully taken place.

Accumulated # of Manual Retransfers

User initiated and successful retransfers to inverter commanded from the manual transfer screen. MM checks the status of output and SBS contactors to verify a transfer has successfully taken place.

Accumulated # of All Transfers

All transfers, manual and auto are counted.

Accumulated # of All Retransfers

All retransfers, manual and auto are counted.

Accumulated # of Overload Conditions

For detection of an overload condition, software monitors 6 alarms (Inv Ovld phA, Inv Ovld phB, Inv Ovld phC, SBS Ovld phA, SBS Ovld phC, SBS Ovld phC). It increments the count if one or more of these alarm conditions are reported.

Accumulated # of Unsuccessful Auto Retransfers

The count is incremented upon receipt of an “Auto Retransfer Failed” alarm from UPSC (UPS Control board).

Average Load%

Running average of 256 KVA samples over 256 seconds.

3.4 Faults, Alarms, Status

This section defines the active fault, alarm, and status indicators, their causes, and the associated system operations performed upon their detection.

3.4.1 Faults

A fault is defined as an undesirable system operating condition that could cause further damage to the system or potentially drop the load. Once detected, faults may trigger an appropriate emergency action such as transferring the load to an alternative power source. Many fault conditions can only be resolved through Operator intervention or service by an Liebert Services technician.

A fault condition must be valid for a certain amount of time before it is recognized as an active fault. This prevents spurious signals from causing false fault detection and unnecessary state changes.

All fault occurrences are time-stamped and recorded in the Event Log for later analysis, and sent to the Operator display.

Fault Messages

Fault messages are displayed in reverse video, as compared with alarm messages which are displayed in regular video.

The following faults are detected by Rectifier DSP.

- Battery Overcharge
- Battery Fuse Fail
- Battery Low Transfer
- DC Overvoltage Transient
- Input Phase Rotation Error
- Rectifier Fuse Fail
- Rectifier Drive 1 Fail
- Rectifier Drive 2 Fail
- Trap Fuse Fail
- Delta/WYE Current Imbalance

The following faults are detected by Inverter DSP:

- Bypass Frequency Error
- Bypass Overload Shutdown
- Bypass Phase Rotation Error
- IDC Peak
- IGBT Drive Fail
- Inverter Overload Transfer
- Inverter Fuse Fail
- Output Overvoltage Transfer
- Output Undervoltage Transfer
- SBS SCR Open
- SBS SCR Shorted
- Inverter current Limit Transfer
- Inverter DC Offset

The following faults are detected by the UPS controls. Corrective actions, where possible, are automatic.

- Active Filter Fail
- Battery Overtemp CB Trip
- Battery Ground Fault CB Trip
- Bypass Power Supply Fail
- EPO Shutdown
- Heatsink Overtemp Limit
- Input Power Supply Fail
- Output Power Supply Fail
- Outlet Air Overtemp Limit
- Power Supply F1 Fail
- SWGR Power Fail
- DC Undervoltage Steady State
- DC Overvoltage Steady State
- Rectifier Fail
- Inverter Fail
- Overtemp Time out Shutdown
- Fault Transfer Failed - Shutdown
- Controller Fault -SBS on.
- Hardware Shutdown.
- MM Control Power Fail.
- MM Memory Fail.
- Option Power Supply Fail

3.4.2 Alarms

An alarm is an indication of an abnormal system condition significant enough to warrant being annunciated and logged. Alarm conditions may indicate that a UPS system parameter is out of its normal operating range, or may signal an external problem. In some cases an alarm may trigger a corrective action. Many alarm conditions will return to normal in due time and the alarm itself will no longer be “active.”

Summary Alarm

The Liebert® Npower™ system features a Summary Alarm, which captures the presence of individual faults and alarms. This alarm may be assigned to any PRB relay. **See Customer Alarm Interface on page 54.**

The Summary Alarm can be accessed from the list of alarms / faults (**Figure 80**) by scrolling up and down the list. (For navigation instructions, see **Customer Alarm Interface on page 54**). When the Summary Alarm is in the active position, it will be flashing at the top of the screen.

Figure 109 Summary alarm in active position screen

ALARM / FAULT NAME	L D F E DELAY
SUMMARY	Y Y N Y 55.15
ON BATTERY	Y Y Y Y 0 0
INPUT CONTACT #1	Y Y Y Y 0 0
INPUT CONTACT #2	Y Y Y Y 0 0
INPUT CONTACT #3	Y N Y Y 0 0
INPUT CONTACT #4	Y Y Y Y 0 0

UP DOWN **SELECT** EXIT DESCRIPTION: L - Latching...D - Dial...

Highlight the SELECT position on the display screen to bring up the Summary Alarm Editing screen, allowing the Operator to edit the parameters of the summary alarm.

Figure 110 Summary alarm editing screen

ALARM FAULT NAME	SUMMARY
LATCHING	NO
DIAL	NO
FREEZE	NO
EVENT LOG	NO

SAVE & EXIT
CANCEL

When the New Alarm, System Summary Alarm, or Module Summary Alarm is activated, you can get more information at the Operator Display Panel, through a remote terminal or a modem. For further information, see 3.5 - **Communication Interfaces**.

Table 6 **Abbreviations used in alarm messages**

Auto	Automatic	OF/UF	Over/Under Frequency
Avail	Available	Ov-temp	Overtemperature
Batt	Battery	O-volt	Overvoltage
Byp	Bypass	Ph Seq	Phase Sequence
Cap Fuse	Capacitor Fuse	Rect Fuse	Rectifier Fuse
Cont Power	Control Power	Rexfer	Retransfer
Equip	Equipment	Shutdn	Shutdown
H/W	Hardware	Static Sw	Static Switch
Inv Fuse	Inverter Fuse	Un-volts	Undervoltage

DISCONTINUED
PRODUCT

Alarm Messages

The alarm message area displays the alarm conditions that are present within the UPS system. The table below shows the default values of masks for each alarm/fault, the meaning of the Alarm and possible corrective actions.

The following information applies to the table.

1. Latch Masks, Dial Masks and unshaded Event log masks may be changed by the user. The user may not change any Freeze Masks.
2. The default alarm names for Input Contact 1 through Input Contact 8 can be modified by the user.

Table 7 Alarms, functions, and corrective actions

Actual Alarm/fault Name Displayed On Front Panel	Description of Alarm/Fault	Fault Or Alarm	Latch Mask	Dial Mask	Freeze Mask	Event Log Mask	Meaning and Corrective Action(s)
Battery Fuse Fail	Battery Fuse Fail	Fault	YES	YES	NO	YES	Control Logic has determined that the battery breaker(s) is closed and the battery fuse has been open for 10 seconds or longer. Battery back-up is no longer available. <i>Liebert® Services should be called immediately.</i>
Battery Low xfer	Battery Low Transfer	Fault	YES	YES	YES	YES	Control Logic has determined that the battery breaker(s) is closed and the battery voltage has dropped below the End of Discharge limit. The UPS will transfer to bypass. If the transfer is successful, the UPS will be shut down. If the transfer was unsuccessful, logic will attempt to complete a System Shutdown before control power is lost. <i>Verify that input power is now available and restart the UPS following the instructions in this manual. If the system fails to restart properly contact Liebert Services.</i>
DC Ov Transient	DC Overvolt Transient	Fault	YES	YES	NO	YES	DC bus voltage is 15% or more over the nominal DC Bus Voltage. The UPS will transfer the load to Bypass and will shut down and isolate the UPS Module. <i>Contact Liebert Services immediately</i>
Inp Phase Rot Error	Input Phase Rotation Error	Fault	NO	NO	NO	YES	The power conductors on the Input line are not wired to the UPS in the required sequence. This alarm should appear only during initial start-up or after a repair to the source power system. <i>Disconnect power from the Input line and correct the wiring. Liebert Services must be present during initial start-up of your UPS System.</i>
Rectifier Fuse Fail	Rectifier Fuse Fail	Fault	YES	YES	NO	YES	At least one fuse has opened. The UPS automatically transfers the critical load to the bypass line. Contactors trip open to shut down and isolate the UPS module. <i>Contact Liebert Services immediately. Do not attempt to reset the circuit breakers.</i>

Table 7 Alarms, functions, and corrective actions (continued)

Actual Alarm/fault Name Displayed On Front Panel	Description of Alarm/Fault	Fault Or Alarm	Latch Mask	Dial Mask	Freeze Mask	Event Log Mask	Meaning and Corrective Action(s)
Trap Fuse Fail	Trap Fuse Fail	Fault	NO	YES	NO	YES	On units equipped with an input filter, Control Logic has determined that one or more of the filter fuses is open. The logic will open the Input filter contactor. The UPS will continue to run, without input filtering. <i>Contact Liebert Service to check and repair the input filter.</i>
On Battery	On Battery	Alarm	NO	NO	NO	YES	Reports an On Battery state as long as the battery CB is closed, Input Undervoltage alarm exists, and the status bit ON UPS is set.
Battery Overcharge	Battery Overchg	Fault	YES	YES	NO	YES	Battery charge current is 50% above the Battery Charge Current Limit for longer than 5 seconds. The load will be transferred to Bypass. If Bypass is not available the UPS will attempt to run from the battery. If both battery and bypass are not available, a full system shutdown will be initiated. This fault will inhibit start-up. <i>Contact Liebert Services immediately</i>
Byp Freq Error	Bypass Frequency Error	Fault	NO	NO	NO	YES	The bypass frequency is outside the $\pm 5\%$ of the system rating. If the load is on bypass the static switch will be shut down and power will be lost to the load. If the load is on UPS, transfer to bypass will be inhibited, until this fault clears or is corrected. This fault will inhibit startup. <i>If fault persists check the bypass source for the cause of the frequency irregularity. Contact Liebert services if you have questions.</i>
Byp ovlid Shutdown	Bypass OverLoad Shutdown	Fault	YES	YES	NO	YES	With the load on Static Bypass the system has determined that at least one phase of the Bypass has exceeded the KVA, KW, or RMS current vs. Time overload spec. The Static Bypass switch will be turned off and the system will be shut down. Power to the load will be turned off. <i>Remove the excess load from the UPS and attempt to re-start. If the load is below the rating of the UPS and it will not re-start, contact Liebert Services.</i>
Byp Phase Rot Error	Bypass Phase Rotation Error	Fault	NO	NO	NO	YES	The power conductors on the bypass line are not wired to the UPS in the required sequence. This alarm should appear only during initial start-up or after a repair to the source power system. <i>Disconnect power from the bypass line and correct the wiring. Liebert Services must be present during initial start-up of your UPS System.</i>
IDC Peak	IDC Peak	Fault	YES	YES	NO	YES	The system has detected a failed IGBT. The unit will transfer to Bypass if available. <i>Contact Liebert Services immediately.</i>

Table 7 Alarms, functions, and corrective actions (continued)

Actual Alarm/fault Name Displayed On Front Panel	Description of Alarm/Fault	Fault Or Alarm	Latch Mask	Dial Mask	Freeze Mask	Event Log Mask	Meaning and Corrective Action(s)
Inverter Ovd xfer	Inverter Overload Transfer	Fault	YES	YES	YES	YES	With the load on UPS, at least one phase of the UPS KVA or KW has exceeded the rated KVA, KW, or RMS current vs. Time equation. (Note: This fault would have been preceded by an "Inverter Overload Phase x alarm.") The UPS will transfer the load to Static Bypass if it is available. If the fault or overload clears the UPS will automatically transfer from SBS to UPS. <i>Remove the excess load from the UPS and attempt to re-start. If the load is below the rating of the UPS and it will not re-start, contact Liebert Services.</i>
Inverter Fuse Fail	Inverter Fuse Fail	Fault	YES	YES	NO	YES	One or more Output Fuses are open. (because of capacitance in the system it may take up to 1 minute after a fuse failure to detect this fault). The system will transfer the load to Static Bypass if available and then shut down the UPS. <i>Contact Liebert Services Immediately.</i>
Output Ov xfer	Output Overvolt Transfer	Fault	NO	YES	YES	YES	The UPS module output voltage is above the maximum (+10%) deviation from nominal. The load automatically transfers to the bypass line. The UPS module is shut down and isolated. <i>Contact Liebert Services at once. Do not attempt to reset circuit breakers.</i>
Output Uv xfer	Output Undervolt Transfer	Fault	NO	YES	YES	YES	The UPS module output voltage is under the minimum (-12%) deviation from nominal. The load automatically transfers to the bypass line. <i>If the alarm condition is no longer present, reset the alarm and retransfer the load from bypass to UPS. Contact Liebert Services if alarm persists.</i>
SBS SCR Open	SBS SCR Open	Fault	YES	YES	NO	YES	This fault can only be detected when the load is on bypass. One or more of the Static Bypass phases are open. The static switch will be shut down and the UPS will shut down. Power to the load will be lost. <i>Contact Liebert Services Immediately.</i>
SBS SCR Shorted	SBS SCR Shorted	Fault	YES	YES	NO	YES	The system has detected a shorted SCR in the Bypass line. If the unit is in the start-up mode, start-up will be inhibited. If the unit is on UPS, the unit will transfer to Bypass and open the output contactor to prevent back feed to the inverter from the Bypass line. <i>Contact Liebert Services Immediately.</i>

Table 7 Alarms, functions, and corrective actions (continued)

Actual Alarm/fault Name Displayed On Front Panel	Description of Alarm/Fault	Fault Or Alarm	Latch Mask	Dial Mask	Freeze Mask	Event Log Mask	Meaning and Corrective Action(s)
Inv I limit xfer	Inverter Current Limit Transfer	Fault	NO	YES	NO	YES	The instantaneous inverter current of any one phase has exceeded its Pulse by Pulse current limit value. An "Inverter Current Limit" alarm was already issued and pulse parallel operation was initiated. At the end of pulse parallel the load current has not be reduced below 150% The load will transfer to Static Bypass. If the fault or over load clears the unit will retransfer to UPS. Check the total load compared to the UPS rating, reduce load where necessary. If the UPS does not retransfer when the load is below 100% of the rated load or if the unit shuts down, contact Liebert Services Immediately.
Batt ovtemp cb trip	Battery Overtemp CB Trip	Fault	YES	YES	NO	YES	With the battery breaker closed and the Battery Overtemp...Breaker Trip" option enabled, the internal battery temperature has exceeded its Maximum set point value. The battery UV trip will be activate and the battery will be disconnected from the UPS. Battery Back up is no longer available. Check the battery to determine the possible cause of the overload and remove if possible. Once the battery has cooled below the set point temperature, the battery may be brought on line again. If the problem recurs contact Liebert Services.
Batt gnd CB trip	Batt gnd fault CB trip	Fault	NO	YES	NO	YES	With BGF option installed, BGF breaker trip enabled, and batt breaker closed, Comms DPS sees its BGF input asserted by the SWGR. It will issue a batt breaker UV trip and motor op disable. To correct, repair and restart batt via the MM. Contact Liebert Services for assistance.
Byb pwr supply fail	Bypass Power Supply Fail	Fault	NO	YES	NO	YES	With Bypass source available, the UPS has determined that the bypass power supply has failed. The SBS will be turned off and the contactors opened. SBS will not be available. This fault will inhibit transfers and start-up. Contact Liebert Services immediately.
EPO shutdown	EPO Shutdown	Fault	NO	YES	NO	YES	The Emergency Power Off switch has been pressed, which caused the UPS system to shut down and remove all power from the critical load. Determine the cause of the emergency condition and correct it if possible. Contact Liebert Services if you require assistance.

Table 7 Alarms, functions, and corrective actions (continued)

Actual Alarm/fault Name Displayed On Front Panel	Description of Alarm/Fault	Fault Or Alarm	Latch Mask	Dial Mask	Freeze Mask	Event Log Mask	Meaning and Corrective Action(s)
Hsink ovtemp limit	Heatsink Overtemp Limit	Fault	YES	YES	YES	YES	The maximum heat sink temperature limit has been exceeded. (Should be preceded by a "Heatsink" Overtemp Warning alarm). The load will be transferred to the Static Bypass if available. If the load was already on SBS when this alarm occurred, the system will shut down. The fault will clear when the temperature falls below the Heatsink Overtemp Warning threshold. (If this fault doesn't clear soon enough it will lead to an "Overtemp Time-out Shutdown"). If the unit is still running it will make an attempt to auto-retransfer when the fault clears. If the faults do not clear; contact Liebert Services.
Inp pwr supply fail	Input Power Supply Fail	Fault	NO	YES	NO	YES	The input source is present, but the input power supply has failed. The unit has redundant power supplies on both the input and the output. Contact Liebert Services immediately.
Out pwr supply fail	Output Power Supply Fail	Fault	NO	YES	NO	YES	The output source is present, but the output power supply has failed. The unit has redundant power supplies on both the input and the output. Contact Liebert Services immediately.
Ups Ambient Limit	UPS Ambient Ot Limit	Fault	YES	YES	YES	YES	The Outlet air temperature has exceeded its maximum set point. The UPS will transfer the load to bypass if available. If already on bypass the system will shutdown. The fault will clear when the temperature falls below the Outlet Air Overtemp Warning threshold. (If this fault doesn't clear soon enough it will lead to an "overtemp Time-out Shutdown"). If the unit is still running when the fault clears it will auto retransfer to UPS. Check all air inlets and exhausts for blockage and check the air filter. Check the actual load against the UPS rating. Remove any excess load. Contact Liebert Services if the alarm persists.
Pwr Supply F1 Fail	Power Supply F1 Fail	Fault	NO	YES	NO	YES	Failure of this fuse will remove control power. The UPS will attempt to transfer to Static Bypass if available. Locate the cause of any failure, before replacing a fuse or Contact Liebert Services Immediately.
SWGR Power Fail	SWGR Power Fail	Fault	NO	YES	NO	YES	UPS will transfer to Static Bypass if available and shut down the UPS. Start-up will be inhibited. Contact Liebert Services.

Table 7 Alarms, functions, and corrective actions (continued)

Actual Alarm/fault Name Displayed On Front Panel	Description of Alarm/Fault	Fault Or Alarm	Latch Mask	Dial Mask	Freeze Mask	Event Log Mask	Meaning and Corrective Action(s)
Rectifier Fail	Rectifier Fail	Fault	YES	YES	YES	YES	This is a summary event based on the detection of at least one of these faults being active: Battery Overcharge; DC Overvoltage Steady State; DC Overvoltage Transient; DC Undervoltage Steady State; Delta-Wye Current Imbalance; Rectifier Fuse Fail; Rectifier Drive 1 Fail; Rectifier Drive 2 Fail. All actions are controlled by the causal fault.
Inverter Fail	Inverter Fail	Fault	YES	YES	YES	YES	This is a summary event based on the detection of at least one of the following; IDC Peak; IGBT Drive Fail; Output Overvoltage Transfer; Output Undervoltage Transfer; Inverter DC Offset. All actions are controlled by the causal faults.
Ovtemp time-out Sd	Ovtemp Time-out Shutdown	Fault	YES	YES	NO	YES	An Equipment Over-temperature condition has persisted for more than 10 minutes. The load is transferred to the bypass line and the UPS module is shut down. Check the air intake, air exhaust, and filters before attempting to start-up the UPS.
Transfer Failed Sd	Transfer Failed Shutdown	Fault	YES	YES	YES	YES	A transfer to Static Bypass was unsuccessfully attempted and power to the load was lost. Attempt to restart the system. Contact Liebert Services.
Ctrl Fault SBS on	Controller fault SBS on	Fault	YES	YES	NO	YES	Indicates that the unit has transferred to SBS without the knowledge of the UPSC. It occurs when the UPSC's Watchdog Fail line is automatically asserted during a UPSC reset. This is a permanent (latched) condition which requires service. Contact Liebert Services at once.
Hardware Sd	Hardware Shutdown	Fault	YES	NO	NO	YES	At least one of the following alarm conditions is present: Inverter Fault, Rectifier Fuse Blown, Reverse Power, Over load Shutdown, logic power supply failure, or inverter output symmetry failure. The load automatically transfers to the bypass line. The UPS module is shut down and isolated. Contact Liebert Services at once. Do not attempt to reset the UPS.
Opt pwr supply Fail	Option Power Supply Fail	Fault	YES	YES	NO	YES	The Option Power Supply has failed. Remote Alarm Status panels may be disabled. Contact Liebert Service.

Table 7 Alarms, functions, and corrective actions (continued)

Actual Alarm/fault Name Displayed On Front Panel	Description of Alarm/Fault	Fault Or Alarm	Latch Mask	Dial Mask	Freeze Mask	Event Log Mask	Meaning and Corrective Action(s)
Batt Discharging	Battery Discharge	Alarm	NO	YES	NO	YES	The battery is discharging. This occurs whenever the battery supplies power to the load for more than five seconds because of input power failure, a rectifier problem, or an overload condition. If the input power or a source of auxiliary power is restored to the UPS module, the UPS automatically returns to normal operation. Watch the battery voltage carefully. Reduce the load (begin controlled shutdown) to extend the battery back-up time. Start the back-up generator, if available. Reset the UPS alarms after the input power is restored. The message clears after 30 seconds.
Input I Imbalance	Input Current Imbalance	Alarm	NO	YES	NO	YES	With input current levels above 30% of nominal and all three phase voltages within 5% of each other, there is a difference between any single input phase current and the average input phase current of more than 25%. The UPS will open the Input filter Contactor. The alarm will clear when the difference in current falls below 20%, but the Input filter contactor will need to be reset, using the front panel. Refer to manual start up instructions.
Input Line Fail	Input Line Fail	Alarm	NO	NO	NO	YES	The rectifier input line voltage is outside of specified limits or the input circuit breaker is opened while the battery circuit breaker remains closed. The battery supplies power to the critical load through the UPS inverter.
Input OF/UF	Input OF/UF	Alarm	NO	YES	NO	YES	The input frequency is $> \pm 5\%$ of the nominal frequency. The UPS will begin using the battery to supply power, if by the end of discharge the problem is not corrected, for single input units power to the load will be lost, for dual input units the system will attempt transfer to Bypass if qualified and available.
Input Phase Loss	Input Phase Loss	Alarm	NO	YES	NO	YES	For all of these input problems the system will supply power from the battery until the end of discharge. At that point single input systems will lose power to the load. Dual input systems will attempt to transfer to bypass if qualified and available. Call Liebert Services for Assistance.
Input UnderVoltage	Input Under Voltage	Alarm	NO	NO	NO	YES	For all of these input problems the system will supply power from the battery until the end of discharge. At that point single input systems will lose power to the load. Dual input systems will attempt to transfer to bypass if qualified and available. Call Liebert Services for Assistance.

Table 7 Alarms, functions, and corrective actions (continued)

Actual Alarm/fault Name Displayed On Front Panel	Description of Alarm/Fault	Fault Or Alarm	Latch Mask	Dial Mask	Freeze Mask	Event Log Mask	Meaning and Corrective Action(s)
Input OverVoltage	Input Over Voltage	Alarm	NO	NO	NO	YES	For all of these input problems the system will supply power from the battery until the end of discharge. At that point single input systems will lose power to the load. Dual input systems will attempt to transfer to bypass if qualified and available. Call Liebert Services for Assistance.
Input current limit	Input Current Limit	Alarm	NO	YES	NO	YES	The RMS input current has reached the Input Current Limit setting. Check the UPS load.
Battery CB Open	Battery CB Open	Alarm	NO	YES	NO	YES	The module battery circuit breaker (MBD) is open. This circuit breaker might have been opened either manually or automatically in a UPS shutdown procedure. If the UPS is operating with this breaker open, the critical load is not protected from loss of the utility source power. Manual closure of the battery breaker is inhibited. You must use the front panel to set up the sequence for manual battery re-closure. Follow the instructions in manual start-up.
Batt Supp Active	Batt supplement is active	Alarm	NO	YES	NO	YES	This condition is indicated when the Batt Discharging and Input Undervoltage alarms are simultaneously active. The alarm will clear when the Inp. Undervoltage alarm clears and/or if the rectifier turns off and/or if the Batt Dischg alarm clears.
Bypass Sync Error	Bypass Sync Error	Alarm	NO	YES	NO	YES	The bypass is out of sync to a sufficient degree that transfer to Static Bypass is inhibited. An interrupted transfer will be permitted only in the case of a critical fault. If this alarm persists, contact Liebert Services.
Byp out Tolerance	Bypass Voltage Out of Tolerance	Alarm	NO	YES	NO	YES	One or more bypass voltages is below 80% or above 115% of the nominal value. If the load is on UPS, and the unit is a dual input unit, transfers to bypass will be inhibited. If the unit is a single input unit, the system will shut down. The Alarm will be cleared 5 seconds after all voltage are again with 85-110% of nominal. If the load has been shut down, re-start will be required.
Bypass Line Fail	Bypass Line Fail	Alarm	NO	YES	NO	YES	The bypass source has dropped below 35V per phase. On single input units, the UPS will shut down. On dual input units, transfer to the bypass will be inhibited. The alarm will be cleared five seconds after all voltages again exceed 45V. If the unit is already on Bypass when this occurs, power to the load will be lost.

Table 7 Alarms, functions, and corrective actions (continued)

Actual Alarm/fault Name Displayed On Front Panel	Description of Alarm/Fault	Fault Or Alarm	Latch Mask	Dial Mask	Freeze Mask	Event Log Mask	Meaning and Corrective Action(s)
SBS Ovid Phase A	SBS Overload Phase A	Alarm	NO	NO	NO	YES	With the load on Static Bypass, the phase A output kVA or kW or RMS current has exceeded 115% of the nominal per-phase kVA or kW or RMS current rating. The UPS will show time remaining until a shutdown will occur, per the Overload vs. time curve. The alarm will clear when the overload falls to below 110% of the rating.
SBS Ovid Phase B	SBS Overload Phase B	Alarm	NO	NO	NO	YES	With the load on Static Bypass, the phase B output kVA or kW or RMS current has exceeded 115% of the nominal per-phase kVA or kW or RMS current rating. The UPS will show time remaining until a shutdown will occur, per the Overload vs. time curve. The alarm will clear when the overload falls to below 110% of the rating.
SBS Ovid Phase C	SBS Overload Phase C	Alarm	NO	NO	NO	YES	With the load on Static Bypass, the phase C output kVA or kW or RMS current has exceeded 115% of the nominal per-phase kVA or kW or RMS current rating. The UPS will show time remaining until a shutdown will occur, per the Overload vs. time curve. The alarm will clear when the overload falls to below 110% of the rating.
Inverter I Limit	Inverter Current Limit	Alarm	NO	NO	NO	YES	The instantaneous inverter current of any one phase has exceeded its pulse-by-pulse current limit value. The UPS will shutdown when the Current Overload vs. time curve is exceeded.
Output OF/UF	Output OF/UF	Alarm	NO	YES	NO	YES	Output frequency differs from the nominal (60Hz) by more than 0.5Hz. No transfer or shutdown occurs. Contact Liebert Services at once.
Inv Ovid Phase A	Inverter Overload Phase A	Alarm	NO	YES	NO	YES	With the load on UPS, Phase x output KVA or KW or RMS current has exceeded 105% of the nominal per phase rating. The UPS will begin sending the time remaining until a transfer or shutdown will occur, per the Overload vs. Time Curve. The alarm condition will clear when the overload returns to below the nominal rating.
Inv Ovid Phase B	Inverter Overload Phase B	Alarm	NO	YES	NO	YES	With the load on UPS, Phase A output kVA or kW or RMS current has exceeded 105% of the nominal per phase rating. The UPS will begin sending the time remaining until a transfer or shutdown will occur, per the Overload vs. Time Curve. The alarm condition will clear when the overload returns to below the nominal rating.

DISCONTINUED PRODUCT

Table 7 Alarms, functions, and corrective actions (continued)

Actual Alarm/fault Name Displayed On Front Panel	Description of Alarm/Fault	Fault Or Alarm	Latch Mask	Dial Mask	Freeze Mask	Event Log Mask	Meaning and Corrective Action(s)
Inv Ovld Phase C	Inverter Overload Phase C	Alarm	NO	YES	NO	YES	With the load on UPS, PhaseB output KVA or KW or RMS current has exceeded 105% of the nominal per phase rating. The UPS will begin sending the time remaining until a transfer or shutdown will occur, per the Overload vs. Time Curve. The alarm condition will clear when the overload returns to below the nominal rating.
Low Pwr Factor Warn	Low Power Factor Warning	Alarm	NO	YES	NO	YES	On any output phase that is supplying at least 15% of its rated KVA, the measured output power factor is below 0.50, leading or lagging.
Pulse Paralleling	Pulse Parallel Activated	Alarm	NO	YES	NO	YES	With the load being supplied by the inverter, the measured load current exceeds the auto-Parallel Current Limit or the Pulse-by-Pulse Current Limit set point values. If the Static Bypass is available, the SBS supplies supplemental power. If at the end of 10 cycles the load current has not returned to below 105%, the Static Bypass will be left on and the inverter will be turned off. If the over current has cleared the Inverter will be left on and the SBS will be turned off.
Auto rexfers failed	Auto Retransfer Failed	Alarm	YES	YES	NO	YES	After performing a recoverable transfer to bypass, with Auto Rexfer enabled, the Auto Rexfer time out (default=5minutes) has elapsed before retransfer could be performed. A manual retransfer must be performed, which will then clear the lockout and zero the retransfer/ hour counter. If the manual transfer is inhibited, the Inverter may be latched off due to another fault. Contact Liebert Services.
Excessive Auto Rexfer	Excessive Auto Retransfer	Alarm	YES	YES	NO	YES	The UPS has determined that the actual number of Auto Retransfers in the past hour has exceeded the permitted maximum. (user settable, default=5). This alarm should not be issued if auto retransfers are disabled by setting the maximum attempts to "0". A manual retransfer must be performed, which will then clear the lockout and zero the retransfer/hour counter.
Aux Power Fail	Aux Power Fail	Alarm	NO	YES	NO	YES	If the unit is supplying power to an Auxiliary device, this alarm indicates that the system has detected a failure in the Aux. Power circuit.
EPO Power Fail	EPO Power Fail	Alarm	NO	YES	NO	YES	If the unit is supplying power to an Auxiliary device, this alarm indicates that the system has detected a failure in the Aux. Power circuit.
LBS Power Fail	LBS Power Fail	Alarm	NO	YES	NO	YES	Power to the Load Bus Sync circuit has been lost. Check external wiring. Contact Liebert Services.

DISCONTINUED
PRODUCT

Table 7 Alarms, functions, and corrective actions (continued)

Actual Alarm/fault Name Displayed On Front Panel	Description of Alarm/Fault	Fault Or Alarm	Latch Mask	Dial Mask	Freeze Mask	Event Log Mask	Meaning and Corrective Action(s)
Batt Gnd Fault	Battery ground fault alarm	Alarm	NO	YES	NO	YES	With the Batt Gnd Fault option installed and the batt breaker closed, the DSP sees its BGF input asserted by the SWGR. No action required.
Aux Ovtemp Warning	Aux Overtemp Warning	Alarm	YES	YES	NO	YES	With the Auxiliary temp sensor installed, it is reading 85% or more of the specified Maximum Aux temperature set point value.
Batt Ovtemp Warning	Battery Overtemp Warning	Alarm	NO	YES	NO	YES	With the battery breaker closed the battery has exceeded the "Battery Temperature Alarm Threshold" set point value.
Heatsink Ovtemp	Heatsink Overtemp Warning	Alarm	NO	YES	NO	YES	Sensors on the power semiconductor heatsinks detect temperatures above the steady state limits for these components. The control logic sets off the alarm but does not shut down the UPS module if the condition lasts less than 10 minutes. Check the air intake, air exhaust, and filters. Reduce the load or transfer it to bypass. Contact Liebert Services if the alarm persists.
Inlet Air Ovtemp	Inlet Air Overtemp Warning	Alarm	NO	YES	NO	YES	The intake air to the UPS module exceeds the specified maximum temperature. <i>This condition only causes an alarm, but should be corrected immediately to prevent equipment overheating. Check to make sure nothing is blocking the inlet air and that the air filter is clean.</i>
Ups Ambient OvTemp	UPS Ambient OvTemp	Alarm	NO	YES	NO	YES	The Outlet air temperature has exceeded 85% of its "Maximum outlet air temperature" limit.
Pwr pole Fan 1 Fail	Power pole Fan 1 Fail	Alarm	NO	YES	NO	YES	A fault in the designated Fan motor has occurred. This condition only causes an alarm, but if not promptly corrected it could cause an equipment over-temperature condition that would shut down the UPS Module. Check the Fans for proper operation. <i>Contact Liebert Services if you require assistance or to replace a fan.</i>
Pwr pole Fan 2 Fail	Power pole Fan 2 Fail	Alarm	NO	YES	NO	YES	A fault in the designated Fan motor has occurred. This condition only causes an alarm, but if not promptly corrected it could cause an equipment over-temperature condition that would shut down the UPS Module. Check the Fans for proper operation. <i>Contact Liebert Services to replace a fan.</i>
Pwr pole Fan 3 Fail	Power pole Fan 3 Fail	Alarm	NO	YES	NO	YES	A fault in the designated Fan motor has occurred. This condition only causes an alarm, but if not promptly corrected it could cause an equipment over-temperature condition that would shut down the UPS Module. Check the Fans for proper operation. <i>Contact Liebert Services to replace a fan.</i>

Table 7 Alarms, functions, and corrective actions (continued)

Actual Alarm/fault Name Displayed On Front Panel	Description of Alarm/Fault	Fault Or Alarm	Latch Mask	Dial Mask	Freeze Mask	Event Log Mask	Meaning and Corrective Action(s)
System Fan Fail	System Fan Fail	Alarm	NO	YES	NO	YES	A fault in the designated Fan motor has occurred. This condition only causes an alarm, but if not promptly corrected it could cause an equipment over-temperature condition that would shut down the UPS Module. Check the Fans for proper operation. <i>Contact Liebert Services to replace a fan.</i>
EPO Latched	EPO Latched	Alarm	NO	NO	NO	YES	During start up the EPO switch is sensed as being activated. Startup is inhibited until the alarm is cleared. <i>Clear the latched EPO via the push-button switch located on the SWGR Board, then perform start up.</i>
SBS Unable	SBS Unable	Alarm	NO	NO	NO	YES	The UPS output is not synchronized to the bypass power source, the static bypass switch is disconnected, or it has failed internally. Emergency and overload transfer to the bypass source is not available. <i>If the module does not have a manual disconnect switch, open and re-close the static switch fuseholder. If the alarm conditions are automatically corrected, reset the alarm to clear it. Contact Liebert Services if the alarm stays on.</i>
Transfer To Byp OK	Transfer To Bypass OK	Alarm	YES	YES	NO	YES	Shows after a successful transfer to Bypass. Display is only momentary.
Low batt capacity	Reduced Battery Capacity	Alarm	YES	YES	NO	YES	Occurs on systems with multiple battery cabinets. Indicates that at least one battery breaker is on and one or more battery breakers in the string are off. In this state, the calculations for battery time remaining and End of Discharge are adjusted accordingly.
Inv Off by User	Inv Off by User	Alarm	YES	YES	NO	YES	The User has turned the inverter off through the front panel. Puts data into the event history log.
Batt Low Warning	Battery Low Warning	Alarm	YES	YES	NO	YES	With the battery breaker closed, the UPS has determined that the DC bus voltage has reached the user settable "Battery Low Warning" set point. <i>Complete the controlled shutdown of the critical load. Reset the alarms if the input power is restored before shutdown.</i>
Batt Test Failed	Battery Test Failed	Alarm	YES	YES	NO	YES	With the battery breaker closed, the battery has failed the self-test. Momentary display. Sets flag in the event history log
Batt Test Passed	Battery Test Passed	Alarm	NO	NO	NO	YES	With the battery breaker closed, the battery has passed the self-test. Momentary display. Sets flag in the event history log
Config Modified	Config Modified	Alarm	NO	NO	NO	YES	The User has modified and saved one or more settings on the configuration screen. Momentary display. Sets flag in the event history log

Table 7 Alarms, functions, and corrective actions (continued)

Actual Alarm/fault Name Displayed On Front Panel	Description of Alarm/Fault	Fault Or Alarm	Latch Mask	Dial Mask	Freeze Mask	Event Log Mask	Meaning and Corrective Action(s)
Delayed Batt Charge	Delayed Battery Charge	Alarm	NO	NO	NO	YES	The generator option is installed, the system is on generator and the "Delayed Battery Charge" is suppressing battery charging to reduce the load on the generator.
Reduced I Limit	Reduced Current Limit	Alarm	NO	NO	NO	YES	The UPS recognizes that the source is a generator and has reduced the current limit setting to avoid generator overloading.
Event Log Clear	Event Log Clear	Alarm	NO	NO	NO	YES	Per the user request, all event logs have been cleared. This will be the first alarm in the new log. Momentary display. Sets flag in the event history log.
Batt Not Charging	Battery Not Charging	Alarm	YES	NO	NO	YES	With the battery breaker closed, the battery voltage has not reached 95% of the units "DC Float Voltage" set point within a calculated time (based on the test duration.) This calculation will start immediately at the end of a successful ("Passed") battery self test.
UPSC-MM comm. Fail	UPSC-MM Comm Fail	Alarm	YES	YES	NO	YES	The UPS has detected a communication failure between its UPS controls and its monitoring system. <i>Contact Liebert Service.</i>
User Shutdown	User Shutdown	Alarm	YES	YES	NO	YES	The User has initiated an "Inverter Off" or "System Shutdown" through the User Shutdown screen.
Cant Exec Batt Test	Cannot Execute Battery Test	Alarm	NO	NO	NO	YES	The battery test could not be performed. See 3.3.7 - Battery Management .
Batt Not Charged	Battery Not Charged	Alarm	NO	NO	NO	YES	A battery test cannot be executed because the battery charge is less than 90%.
Sys Time Set By Op	System Time Set By Operator	Alarm	YES	YES	NO	YES	The User has changed the Date or Time from the front Panel. Momentary display. Sets flag in the event history log.
Manual XFER	Manual Transfer	Alarm	NO	NO	NO	YES	The User has ordered a manual transfer from UPS to Bypass from the front panel controls. Momentary display. Sets flag in the event history log.
Manual ReXFER	Manual Retransfer	Alarm	NO	NO	NO	YES	The User has ordered a manual transfer from Bypass to UPS from the front panel controls. Momentary display. Sets flag in the event history log.
Batt Cycle Buff Full	Battery Cycle Buffer Full	Alarm	NO	NO	NO	YES	With batt breaker closed, Monitor has determined that the buffer that keeps track of the number of hits the battery has taken is full. No action required.
Auto Restart Failed	Auto Restart Failed	Alarm	NO	NO	NO	YES	If Auto Restart feature is installed and enabled, and the last shutdown was due to a failed Batt Low Transfer, the Monitor will automatically attempt to perform the "normal" startup sequence when power is reapplied to normal value. This alarm is issued if the restart could not be performed before the Auto Restart timeout expired. The Monitor will abort the auto restart.

Table 7 Alarms, functions, and corrective actions (continued)

Actual Alarm/fault Name Displayed On Front Panel	Description of Alarm/Fault	Fault Or Alarm	Latch Mask	Dial Mask	Freeze Mask	Event Log Mask	Meaning and Corrective Action(s)
Auto Rexfer Primed	Auto Retransfer Primed	Alarm	NO	NO	NO	YES	An automatic retransfer will be initiated when the OK to Transfer condition has been present for 10 seconds, if the overload has dropped below 100% of the rated load.
LBS Active	LBS Active	Alarm	NO	NO	NO	YES	The Load Bus Sync Option is active.
On Gen Active	On Gen Active	Alarm	NO	NO	NO	YES	A generator is supplying the system.
Load On UPS	Load On UPS	Alarm	NO	NO	NO	YES	The Static Switch is off and the load is on UPS. Momentary display. Sets flag in the event history log.
Load On Bypass	Load On Bypass	Alarm	NO	NO	NO	YES	The critical load is being supplied power from the bypass line, and is therefore exposed to utility power disturbances. <i>Clear all of the alarms before attempting to retransfer the load from the bypass line to the UPS</i>
Password Entered	Password Entered	Alarm	YES	NO	NO	YES	The User has modified the Password. Momentary display. Sets flag in the event history log.
Auto Restart Init	Auto Restart Initiated	Alarm	NO	NO	NO	YES	If the Auto Restart feature is installed and enabled, and the last shutdown was due to a failed Batt Low Txfer, the Monitor automatically initiates the "normal" startup sequence when the source power is reapplied to normal value. This alarm is issued as notification that auto-restart has begun. No action required.
Normal Operation	Normal Operation	Alarm	NO	NO	NO	YES	Notification that no active alarms/faults exist. Sets flag in the event history log.
User Startup init	User Startup	Alarm	NO	NO	NO	YES	User has initiated either a Manual or Auto Start-up from the Start-up/Shutdown screen.
Input Contact #1	Input Contact #1	Alarm	YES	YES	NO	YES	The System has been notified from the OC-DI option that a customer alarm has been activated. The system will substitute user-defined text when displaying these alarms.
Input Contact #2	Input Contact #2	Alarm	YES	YES	NO	YES	The System has been notified from the OC-DI option that a customer alarm has been activated. The system will substitute user-defined text when displaying these alarms.
Input Contact #3	Input Contact #3	Alarm	YES	YES	NO	YES	The System has been notified from the OC-DI option that a customer alarm has been activated. The system will substitute user-defined text when displaying these alarms.
Input Contact #4	Input Contact #4	Alarm	YES	YES	NO	YES	The System has been notified from the OC-DI option that a customer alarm has been activated. The system will substitute user-defined text when displaying these alarms.

Table 7 Alarms, functions, and corrective actions (continued)

Actual Alarm/fault Name Displayed On Front Panel	Description of Alarm/Fault	Fault Or Alarm	Latch Mask	Dial Mask	Freeze Mask	Event Log Mask	Meaning and Corrective Action(s)
Input Contact #5	Input Contact #5	Alarm	YES	YES	NO	YES	The System has been notified from the OC-DI option that a customer alarm has been activated. The system will substitute user-defined text when displaying these alarms.
Input Contact #6	Input Contact #6	Alarm	YES	YES	NO	YES	The System has been notified from the OC-DI option that a customer alarm has been activated. The system will substitute user-defined text when displaying these alarms.
Input Contact #7	Input Contact #7	Alarm	YES	YES	NO	YES	The System has been notified from the OC-DI option that a customer alarm has been activated. The system will substitute user-defined text when displaying these alarms.
Input Contact #8	Input Contact #8	Alarm	YES	YES	NO	YES	The System has been notified from the OC-DI option that a customer alarm has been activated. The system will substitute user-defined text when displaying these alarms.

**NOTE**

There are 8 alarms on the Remote Alarm Status Panel. See 3.5.3 - Remote Alarm Status Panel

3.4.3 Status

Status conditions give the Operator additional knowledge about UPS operation. Some are indicated on the Mimic Display screen by a text message while others are depicted graphically.

The following status messages may appear in the Operator display.

- Static Switch Connected. The static switch is connected (the disconnect switches are closed - ON) and is ready to provide a current path from the bypass input to the load.
- Static Switch Disconnected. The static switch is disconnected (the disconnect switches are open - OFF) for maintenance procedures.
- OK to Transfer. The UPS system voltage, frequency, and phase match the bypass line. This means that a transfer between the bypass line and the UPS is permitted.
- Not OK to Transfer. Either the UPS or bypass voltage, frequency, or phase is not within the specified limits or the static bypass switch is not available. Therefore, manually-initiated transfer between the bypass line and the UPS is not permitted. Emergency or overload transfer to bypass may still be available provided the “Static Switch Unable” alarm is not indicating.
- Time to Overload Transfer. During an overload condition, the time remaining before transfer (in seconds) is displayed at the bottom of the load block.

3.5 Communication Interfaces

The Liebert® Npower™ UPS can be configured with various communication ports to assist the Operator in monitoring the UPS system.

3.5.1 RS-232 Port: Local Reporting Terminal

The Liebert® Npower™ transmits UPS system status and history information to a remote terminal through an RS-232 Port in ASCII Format. This feature is called the Service Terminal. The service terminal interface is intended to be accessed via PC terminal emulation software like Procomm Plus, Microsoft Windows Terminal or Hyperterminal, or directly through a standard ASCII terminal.

A summary of Liebert Npower service terminal commands is provided in **Table 8** below. Two types of commands are identified: operational (OPS) and diagnostic (DIAG). Operational commands deal primarily with machine operations: metering, alarm events and transient analysis. This information is also available through the front panel Operator interface. Diagnostic commands are intended to allow manipulation of the internal machine operating parameters. Access to these commands is limited through password protection.

Table 8 Service terminal command summary

Command	Type	Description
?	OPS	Reports a command listing (same as HELP?) OR provides help with specific commands.
AA?	OPS	Reports active alarms.
AF?	OPS	Reports active faults.
DATE?	OPS	Reports the current date.
EL?	OPS	Reports entire event log, most recent on top.
HELP?	OPS	Reports a command listing (same as?) OR provides help with specific commands.
HL?	OPS	Reports the entire requested history log (comma delimited) if frozen, from oldest frame to newest.
SPT?	OPS	Reports setpoints for group number.
SR?	OPS	Reports active status reports.
TIME?	OPS	Reports the current time in military format.
UPMDR?	OPS	Reports metering data using real values.

In addition to the local RS-232 Port, Liebert Npower will interface with an External modem which uses the same ASCII command set. Likewise the SiteScan port can support SiteScan communications. Whatever communication options are installed in the Liebert Npower UPS can all be used simultaneously.

3.5.2 Worldwide Reporting

The Liebert Npower has a standard Interface Terminal Block to connect to an optional external modem. An internal optional modem can also be installed, although the external modem cannot be utilized if the system is configured with an internal modem. The internal modem is compatible with standard analog telephone lines and most standard telephone equipment. The internal or external modems allow you to configure the UPS to:

1. Make outgoing calls to a computer in an attempt to notify of a pressing alarm condition.
2. Accept incoming calls so a remote computer can connect to the UPS and serve as a monitoring station.
3. Make outgoing calls to a pager.

Auto-Dial

The Liebert Npower will automatically dial a pre-programmed (customer-selected) phone number when specified alarm conditions occur. The auto-dial phone number, an alternate number, and the modem baud rate are programmed by using the System Configuration screen. (See Options Manual for programming instructions.) The alarm messages that initiate an auto-dial call are identified in **Table 7**.

When the auto-dial function is initiated, automatic dial attempts three times to dial the first phone number at 45 second intervals. If unanswered, the system rolls over to the second number and repeats the sequence. After three tries on each line, the auto dial function is discontinued, at which point the pager module (See **Dial Out Pager on page 92**) gains access to the modem.

Once a connection is made, the system transmits the information on the Present Status Report screen, then hangs up. The Present Status Report in ASCII Format includes the UPS system identification number, date, time, alarm messages and metered parameter indications.

Requesting Information

If your Liebert® Npower™ UPS is equipped with a modem and telephone line, you can call the UPS and receive system status and historical information. You can place the call from either a remote terminal or a personal computer with a communications program.

Follow the instructions for your terminal or your communications program to call the UPS. (See Options Manual for details.) Once connected, the UPS will respond to your specific requests for information (See **Table 8**).

For example, to see a copy of information on the active status reports, enter the command, “SR” and press ENTER. The Liebert Npower UPS will send the data, which will be displayed on your screen. Please note that the data on the screen is like a snapshot -- the status of the UPS at the moment you requested the information. The information sent remotely is not updated, although you can repeat the process at intervals to request the present information.

Some screens contain data that you may wish to import into a spreadsheet for further calculations. To put this data into a usable format, use the screen-capture feature of your communications software (or a separate screen-capture program) to save all or part of the data to disk. Hint: If you save the file with an extension of “.txt,” it can then be imported into a spreadsheet program and converted to worksheet format.

To terminate your connection to the Liebert Npower, type “Quit” and press Enter. The UPS will hang up its modem and await your next call.

Dial Out Pager

The Dial Out Pager requires the modem option to be installed. (It works with both the external and internal modems) Its function is to provide pager support (alphanumeric and numeric) for the Liebert Npower system.

The Pager Support Screen can be accessed by starting with SYSTEM CONFIGURATION, and navigating to COMM OPTIONS, and then to PAGER SUPPORT CONFIGURATION.

Figure 111 Pager support screen

PAGER SUPPORT CONFIGURATION	
PAGER ENABLED	: YES
PAGER PHONE NUMBER	: 8003433433
PIN NUMBER	: 11111111
EXIT	

From this screen you can enable or disable the pager, and set it to the pin number required for alphanumeric paging on Skytel.

The PAGER ENABLED field can be set to YES or NO. This is interlocked with the modem option. Pager support requires the modem.

The PAGER PHONE NUMBER: can have a maximum of 20 digits. This entry is blank when the NVRAM is first initialized.

The PIN NUMBER can have a maximum of 20 digits. The default pin number is 00000000

Note: Changes to these pager parameters aren't saved into NVRAM until you select “Save & Exit” when you leave the configuration menu screens.

PROTOCOL

The pager module uses the Telocator Alphanumeric Protocol (TAP), which is the protocol used for SkyTel pagers. A copy of this protocol is included with the pager option. Pager support requires the same hardware that modem support requires. The internal modem is quite adequate.

Since the pager option uses the same modem that the modem option uses, careful thought has gone into the sharing of one modem. For example, incoming connections take precedence over dial out alarms or pager alarms. When a dial out alarm is articulated, each number is tried at least 3 times before giving up. After giving up, the pager module gains access to the modem, and will begin trying to send the alarm to a pager. If modem dial out is disabled but pager dial out is enabled, the pager alarm will skip the modem dial out module and proceed immediately to the pager module dial out.

When an alarm message is sent to the pager, it includes a system header and a data portion that looks like the following:

```
System ID# 00000000 System Tag # 00000000
```

```
1 BATTERY FUSE FAIL 5/11/01 3:22 PM
```

A list of alarms, masks, and corrective action is shown in **Table 7**.

3.5.3 Remote Alarm Status Panel

The Liebert® Npower™ UPS may be ordered with an Optional Remote Alarm Status Panel. This remotely-mounted panel (within 500 feet), provides an LED indication of the following Alarm conditions:

- Load On UPS
- Load On Bypass
- Battery Discharge
- Low Battery Warning
- Overload
- Ambient Overtemp
- System Summary Alarm
- New Alarm

The Remote Alarm Status Panel housing is a NEMA Type I enclosure, available for remote mounting on walls or columns. The Remote Alarm Status Panel displays the 8 alarms specified above. Signals for the alarms are carried over a 4-wire connection (customer supplied) which connects the Liebert Npower CANBUS data link and Optional Power Supply to the Remote Alarm Status Panel.

3.5.4 Liebert SiteScan

The SiteScan port sends UPS system information to a Liebert SiteScan® Central Monitoring System. UPS operation, environmental control systems, and facility security can all be monitored from a single location.

3.5.5 Setting Up External Communication Devices

All external communication devices, including the modem, are optional equipment. Connections to communication ports are made by wiring cables to terminal boards. Connection points are shown on the Control Wiring Interconnect Diagram in the Installation Manual. Contact Liebert® Services for assistance when attaching an external device to your UPS system.

Any terminal that accepts the standard 7-bit ASCII codes and conforms to the data link requirements can be used to interface with the Liebert Npower™ UPS. If a printer is used, the terminal must support it. The UPS does not send or receive any printer control commands.

Data link requirements are:

- Asynchronous RS-232 communication
- Terminals may be configured as DTE or DCE
- Baud Rate:
 - Modem 1200 or 2400
 - Terminal 9600 only
- Data Bits: 8
- Stop Bits: 1
- Parity: None
- Handshaking: Not required
- Full Duplex

3.6 Modes of Operation

This section illustrates the flow of power through circuit breakers, switches, and UPS components during various modes of operation. The same modes of operation apply to all configurations of the Liebert Npower UPS. Highlighted (thick) lines in the diagrams indicate power flow and power availability.

3.6.1 Load on Bypass

Load on bypass, with the UPS not available, is shown in the figure below. The UPS system could be in this mode of operation during either initial startup or UPS system shutdown and isolation for maintenance.

Figure 112 Load on bypass, UPS not available

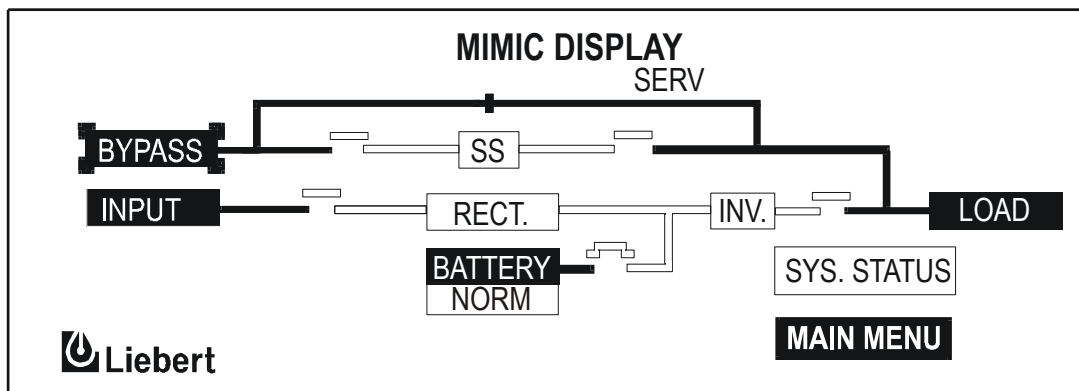

3.6.2 OK to Transfer

The OK to Transfer status message will be displayed when the bypass line and UPS system output power are both available, their voltage, frequency, and phase synchronization are matched within specifications, and the Static Switch Disconnects are closed (ON). An alarm message may be displayed to indicate Load on Bypass. If no alarm is displayed, the operating status is Load On UPS.

When the OK to Transfer message is displayed, you can perform a manual transfer of the load from the UPS system to bypass, or a manual retransfer of the load from bypass to the UPS system. See **3.3.6 - Manual Transfer** for more information.

Figure 113 Load on bypass (UPS available and battery charging)

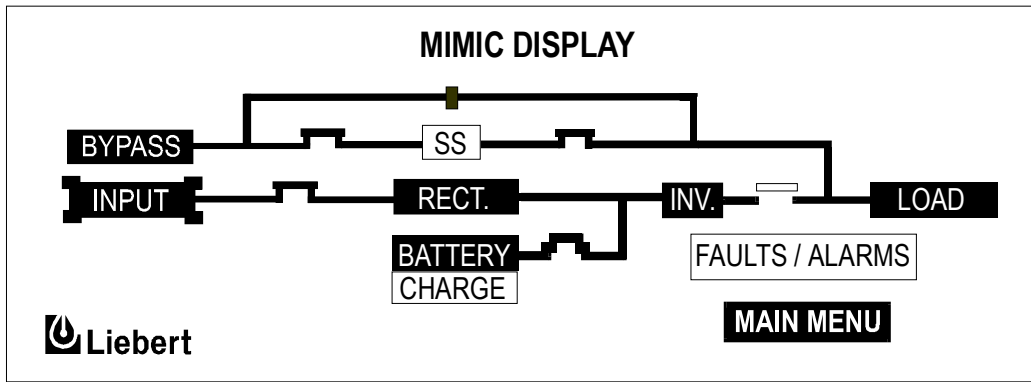

3.6.3 Momentary Overloads

An overload in the critical load will continue to be supplied by the UPS system if the overload condition does not exceed the current versus time curve of overload capacity for the UPS.

For momentary overloads exceeding 200% of rated system current, the static switch turns on for 10 cycles. This provides current from the bypass line in parallel with current from the UPS system output. By providing two power sources simultaneously, high current can be supplied to the critical load with full output voltage regulation. The critical load can be sustained through inrush currents and momentary faults.

If an overload situation exceeds 10 cycles, the UPS module continues to supply power to the critical load if it remains within the current-versus-time curve of overload capacity. If the system overload capacity is exceeded, the UPS control logic initiates an automatic transfer to the bypass line by operating the static bypass switch and the contactors (output and bypass).

3.6.4 Input Power Failure (Load on Battery)

If the utility AC power source fails, or is outside the acceptable range, the battery plant becomes the power source for the UPS module inverter. The UPS system continues to supply power to the critical load, and also to the UPS controls.

You can use the Battery Time screen at the UPS modules to monitor the present battery voltage compared to the shutdown value. The length of time the battery can sustain the load depends on the size of the load and the size and condition of the battery plant. The battery plant is typically large enough to supply a 100% rated load for 15 minutes.

Alarm messages that indicate battery status are Battery Discharge, Low Battery, and Battery Shutdown. The voltage limits for these alarms are displayed on the UPS module Alarm Limit Settings screen. These limits were selected for your installation by Liebert® Services during initial start-up.

Figure 114 Utility fail, load on battery

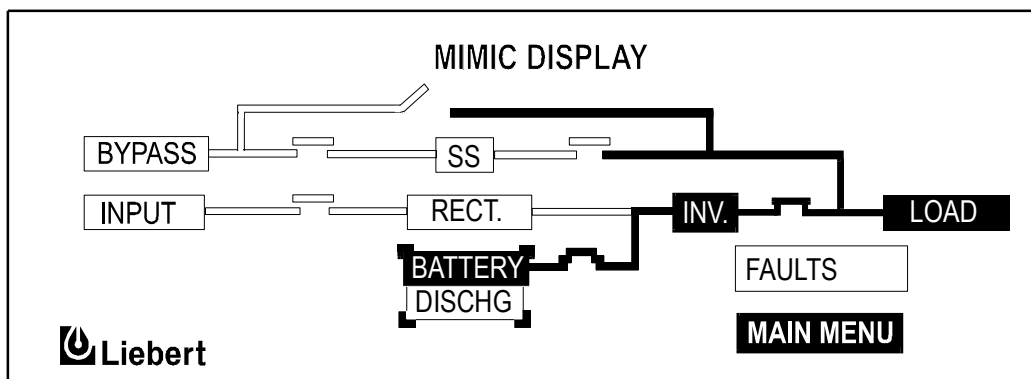

DISCONTINUED PRODUCT

3.6.5 Automatic Operations

The Liebert® Npower™ UPS is designed to function while attended or unattended by an Operator. The system control logic monitors the performance of the UPS, the availability of power sources, and the current required by the critical load.

Automatic UPS operations are described in the following sections.

Overloads

The UPS system is capable of sustaining full output voltage for overload conditions that remain within or under the current versus time curve of system overload capacity.

For high current demands of short duration (momentary overloads) the critical load is supplied simultaneously by both the UPS system and the bypass line. Whenever the critical load requires more than 200% of the capacity of the module, the bypass line will supply up to 6000 amperes for one-half cycle.

If an overload condition exceeds the UPS system overload capacity or the capacity of the modules online, the UPS system initiates an automatic load transfer to the bypass line.

Automatic Transfers to Bypass

The UPS system will initiate an automatic load transfer to the bypass line if an overload condition exceeds the current-versus-time curve of overload capacity, or if specified UPS system faults occur.

The Overload Transfer and Output Under-Voltage alarm conditions will initiate an automatic transfer to bypass and the Load On Bypass message will be displayed. The Status Report screens will include the Automatic Transfer to Bypass message. Other UPS system faults will initiate an automatic transfer to bypass followed immediately by the shutdown and isolation of the UPS system. The static bypass switch is closed and the contactor is closed. Bypass power is supplied to the critical load through the static bypass switch.

Automatic Re-Transfers to UPS

Automatic Retransfer to UPS is an option that you can select from the System Configuration screen. If you do not want the UPS system to initiate any automatic re-transfers, set Max Auto-Rexfer Attempts to zero (0).

In an automatic retransfer, the output contactor closes and the static bypass switch opens.

The following conditions must be present to initiate an automatic retransfer of the critical load from the bypass source to the UPS inverter:

- The number of Auto-Rexfer Attempts selected must be greater than zero (0).
- Critical load was initially transferred to the bypass source due to a system overload only. A manual retransfer from bypass is required if the transfer to bypass was caused by any condition other than output overload.
- The load has since dropped below 100% of the rated load.
- Both the Input contactor and the Battery (MBD) remain closed since the overload transfer.
- OK to Transfer signal received from the control logic for at least 10 seconds, within 5 minutes of the system overload transfer. A manual retransfer from bypass is required for overloads lasting 5 minutes or more.
- Cyclic overloads, which occur up to five (select range is 0 to 5) times in 60 minutes, are automatically returned to the inverter for each event including the Nth overload. A manually initiated retransfer from bypass is required for the N + 1 overload.

Automatic Module Off Line

For specified UPS system faults, the control logic will initiate an automatic transfer to bypass followed immediately by a shutdown and isolation of the UPS system. All UPS contactors and the battery circuit breaker are opened. The static bypass switch will close if the bypass line is available. Note that the bypass line is usually not available during Low Battery Shutdown.

The following UPS system faults will initiate an automatic transfer to bypass:

- DC Over-Voltage Shutdown
- Hardware Shutdown
- Inverter Fault
- Low-Battery Shutdown
- Output Over-Voltage
- Overload Shutdown
- Over-Temperature Time out
- Rectifier Fuse Blown
- Reverse Power

Refer to **3.4 - Faults, Alarms, Status** for more information regarding these alarm messages.

4.0 MAINTENANCE

4.1 Safety Precautions

Observe the safety precautions in **1.0 - Introduction**.

ONLY qualified service personnel should perform maintenance on the UPS system.

Observe ALL of the warnings and cautions below before performing ANY maintenance on the UPS System and associated equipment. Also observe the manufacturer's safety precautions pertaining to the battery, along with the battery safety precautions in this section.



CAUTION

Only Liebert® or Liebert-trained service personnel should work on this equipment. Both AC and DC high voltages are present in lethal amounts within this equipment. Extreme care should be taken when working around UPS equipment.

Always identify the source of connecting wiring prior to disconnecting. Mark any disconnected wires, so they can be properly reconnected.

Do not substitute parts except as authorized by Emerson Network Power.

Maintain the UPS cabinets free of foreign materials such as solder, wire cuttings, etc.

Call Liebert Services if you are not sure of the procedures to follow or if you are not familiar with the design or operation of the equipment.



WARNING

Extreme caution is required when performing maintenance.

Be constantly aware that the UPS system contains high DC as well as AC voltages. With input power off and the battery disconnected, high voltage at filter capacitors and power circuits should be discharged within 30 seconds. However, if a power circuit failure has occurred, you should assume that high voltage may still exist after shutdown. Check with a voltmeter before making contact.

AC voltage will remain on the bypass and output contactors and the static bypass switch, unless associated external circuit breakers are opened.

Check for voltage with both AC and DC voltmeters prior to making contact.

When the UPS system is under power, both the operator and any test equipment must be isolated from direct contact with earth ground and the UPS chassis frame by using rubber mats.

Some components within the cabinets are not connected to chassis ground.

Any contact between floating circuits and the chassis is a lethal shock hazard. Use differential oscilloscopes when measuring a floating circuit. The differential input should have at least 800 vrms common mode input rating and a common mode rejection ratio of at least 80db.

Exercise caution that the test instrument exterior does not make contact either physically or electrically with earth ground.

In case of fire involving electrical equipment, use only carbon dioxide fire extinguishers, or others approved for use in electrical fire fighting.

4.2 Routine Maintenance

You are encouraged to become thoroughly familiar with the equipment, but at no time should you go beyond the specific procedures in this manual while performing maintenance or correcting a malfunction. If you have any doubt as to what must be done, call Liebert® Services at 1-800-LIEBERT for further instructions. The UPS is designed for unattended operation, but does require some common sense maintenance.

- Keep good records.
- Troubleshooting is easier if you maintain historical service records.
- Keep it clean: Maintain the UPS free of dust and any moisture.
- Keep it cool:
 - Battery systems must be kept in the range of 72-77° F (22-25° C) in order to meet design specifications for capacity and longevity.
 - The UPS will reliably meet all performance specifications at temperatures up to 104° F (40°C), and can be slightly derated for operation at even higher temperatures. However, performance and longevity will be optimized when the UPS is operated at the same temperature as the batteries.
- Keep connections tight.
- Tighten all connections at installation and at least annually thereafter. (See **4.2.5 - Torque Requirements**).

4.2.1 Record Log

Set up a maintenance log to record scheduled checks and any abnormal conditions.

The log should have space for all metered data including phase readings, alarm messages, UPS mode of operation, air filter replacement date, and observation notes. A second log should be maintained for the battery module as directed by the battery manufacturer.

A periodic walk-through inspection of the UPS and battery rooms is advised to check for visible and audible indications of problems. Log the inspection, metered parameter indications, and any discrepancies.

4.2.2 Air Filters

The air filters must be inspected and serviced on a regular schedule. The period between inspections will depend upon environmental conditions. Under normal conditions, the air filters will require cleaning or replacement approximately every two months.

All Liebert Npower™ models have replaceable filter elements behind the grille in the front of the unit. This element can be changed with the UPS operating, by opening the outer door for access.

Abnormal or dusty conditions will require more frequent cleaning and replacement of air filters. Inspect installations in new buildings more often, then extend the inspection period as experience dictates.

4.2.3 Battery Maintenance



WARNING

These maintenance procedures will expose hazardous live parts. Refer servicing to qualified personnel.

DC fuses operate at the rated battery voltage at all times. A blown DC bus fuse indicates a serious problem. Serious injury or damage to the equipment can result if the fuse is replaced without knowing why it failed. Call Liebert Services for assistance.

4.2.4 Battery Safety Precautions

Servicing of batteries should be performed or supervised by personnel experienced with batteries and the required precautions. Keep unauthorized personnel away from batteries.

When replacing batteries, use the same number and type of batteries.



WARNING

Lead-acid batteries contain hazardous materials. Batteries must be handled, transported, and recycled or discarded in accordance with federal, state, and local regulations. Because lead is a toxic substance, lead-acid batteries should be recycled rather than discarded.

Do not dispose of battery or batteries in a fire. The battery may explode.

Do not open or mutilate the battery or batteries. Released electrolyte is harmful to the skin and eyes. It may be toxic.

A battery can present a risk of electrical shock and high short circuit current. The following precautions should be observed when working on batteries:

- Remove watches, rings and other metal objects.
- Use tools with insulated handles.
- Wear rubber gloves and boots.
- Do not lay tools or metal parts on top of batteries.
- Disconnect charging source prior to connecting or disconnecting battery terminals.
- Determine if battery is inadvertently grounded. If inadvertently grounded, remove source of ground. Contact with any part of a grounded battery can result in electrical shock. The likelihood of such shock will be reduced if such grounds are removed during installation and maintenance.
- Lead-acid batteries can present a risk of fire because they generate hydrogen gas. In addition, the electrical connections must be protected against accidental short circuits which can cause sparks. The following procedures should be followed:
 - DO NOT SMOKE when near batteries.
 - DO NOT cause flame or spark in battery area.
 - Discharge static electricity from body before touching batteries by first touching a grounded metal surface.
 - After replacing battery jars in a battery cabinet, replace the retaining straps that hold the jars in place on the shelves. This will limit accidental movement of the jars and connectors should the cabinet ever need to be repositioned or relocated.

Regular maintenance of the battery module is an absolute necessity. Periodic inspections of battery and terminal voltages, specific gravity, and connection resistance should be made. Strictly follow the procedures outlined in the battery manufacturer's manual. (See battery manufacturer's web site.)

Valve-regulated lead-acid batteries do require periodic maintenance. Although they do not require maintenance of electrolyte levels, visual inspections and checks of battery voltage and connection resistance should be made.



NOTE

Do not use cleaners on the batteries. Solvents can make the battery cases brittle. Use only a dry cloth or a cloth moistened in water

Since individual battery characteristics are not identical and may change over time, the UPS module is equipped with circuitry to equalize battery cell voltages. This circuit temporarily increases charging voltage to maintain flooded type battery cells at full capacity.



NOTE

Do not use equalize charging with valve-regulated lead-acid batteries, such as those used in Liebert® Battery Cabinets.

Consult the battery manufacturer's manual for specific information about equalize charging.

4.3 Detecting Trouble

It is important that the operator check the instrument readings if abnormal equipment performance is suspected. Any metered value that differs appreciably from normal could mean an impending malfunction, and should be investigated.

Items to check on the various UPS display screens include:

1. Output voltage of all phases should be within 2% of normal voltage. Output currents on each phase should not normally differ by more than 20%. If a greater difference is noted, the load is unbalanced and corrective action should be taken to redistribute the load, if possible.
2. If the UPS has not operated on battery power during the last 10 hours, the batteries should require little charging current. Battery mimic should indicate normal DC voltage with relatively little battery charge current.
3. Input current on each phase should be within 10% of the average input current. Alarm messages indicate malfunction or impending malfunction. A daily check of the Operator Control Panel will help to provide an early detection of problems. Refer to **Table 7** to interpret alarm messages.
4. Tracing a problem to a particular section is facilitated by alarm messages and the metered parameter indications. These are stored in the Status Reports and can be displayed at the Operator Control Panel or at an optional terminal.



NOTE

If the UPS system has a blown fuse, the cause should be determined before you replace the fuse. Contact Liebert® Services.

4.4 Reporting a Problem

If a problem occurs within the UPS, review all alarm messages along with other pertinent data. This information should be given via telephone to the Liebert Service dispatcher. This information can also be automatically sent by telephone modem. Call 1-800-LIEBERT to report a problem or to request assistance.

4.5 Corrective Actions

For each alarm message on the Operator Control Panel and the Remote Alarm Status Panel, you can find the recommended corrective action in **3.4.2 - Alarms**.

4.6 Recommended Test Equipment

A list of recommended test equipment and tools required to maintain, troubleshoot, and repair the UPS module is given in Table 4-2. You may substitute instruments of equivalent range and accuracy. All instruments should be calibrated and be within the current calibration cycle. Calibration data for the instruments should be maintained in equipment-history files and the instruments labeled for audit and verification.

Table 12 Recommended test equipment and tools

Qty	Test Equipment	Manufacturer	Model or Type
1	Oscilloscope	Tektronix, H-P or Fluke	DC to 50 MHz
2	Voltage Probes	Tektronix, H-P or Fluke	10X, with 10 ft. Cable
2	Voltage Probes	Tektronix, H-P or Fluke	100X, with 10 ft. Cable
1	Digital Multi-meter	Fluke	8060, with Test Leads
1	Tool Kit	N/A	Standard electrical contractor tools

DISCONTINUED
PRODUCT

Ensuring The High Availability Of Mission-Critical Data And Applications.

Emerson Network Power, a business of Emerson (NYSE:EMR), is the global leader in enabling *Business-Critical Continuity™* from grid to chip for telecommunication networks, data centers, health care and industrial facilities. Emerson Network Power provides innovative solutions and expertise in areas including AC and DC power and precision cooling systems, embedded computing and power, integrated racks and enclosures, power switching and controls, infrastructure management, and connectivity. All solutions are supported globally by local Emerson Network Power service technicians. Liebert AC power, precision cooling and monitoring products and services from Emerson Network Power deliver Efficiency Without Compromise™ by helping customers optimize their data center infrastructure to reduce costs and deliver high availability.

While every precaution has been taken to ensure the accuracy and completeness of this literature, Liebert Corporation assumes no responsibility and disclaims all liability for damages resulting from use of this information or for any errors or omissions.

© 2010 Liebert Corporation

All rights reserved throughout the world. Specifications subject to change without notice.

® Liebert is a registered trademark of Liebert Corporation.

All names referred to are trademarks or registered trademarks of their respective owners.

SL-24534_REV3_09-12

Technical Support / Service

Web Site

www.liebert.com

Monitoring

liebert.monitoring@emerson.com

800-222-5877

Outside North America: +00800 1155 4499

Single-Phase UPS & Server Cabinets

liebert.upstech@emerson.com

800-222-5877

Outside North America: +00800 1155 4499

Three-Phase UPS & Power Systems

800-543-2378

Outside North America: 614-841-6598

Environmental Systems

800-543-2778

Outside the United States: 614-888-0246

Locations

United States

1050 Dearborn Drive

P.O. Box 29186

Columbus, OH 43229

Europe

Via Leonardo Da Vinci 8

Zona Industriale Tognana

35028 Piove Di Sacco (PD) Italy

+39 049 9719 111

Fax: +39 049 5841 257

Asia

29/F, The Orient Square Building

F. Ortigas Jr. Road, Ortigas Center

Pasig City 1605

Philippines

+63 2 687 6615

Fax: +63 2 730 9572

Emerson Network Power.

The global leader in enabling *Business-Critical Continuity™*

- | | | | |
|----------------|--|------------------------------|-------------------------------|
| ■ AC Power | ■ Embedded Computing | ■ Outside Plant | ■ Racks & Integrated Cabinets |
| ■ Connectivity | ■ Embedded Power | ■ Power Switching & Controls | ■ Services |
| ■ DC Power | ■ Infrastructure Management & Monitoring | ■ Precision Cooling | ■ Surge Protection |