

PRODUCT SPECIFICATION

Lithium Ion Battery System for UPS – U6A4

(34.6kWh, 32.6kWh, 28.5kWh, 26.5kWh, 20.4kWh)

Revision History

Revision	Date	Description	Pages Changed
0.0	2019.06.22	First draft	
0.1	2019.09.24	SMU Auxiliary switch and SMPS Status auxiliary contact electrical ratings added (Table 10, Table 17)	22, 28
0.2	2019.11.14	Dimensions corrected	14
0.3	2019.12.05	Maximum operating altitude spec added	14
0.4	2020.08.11	Product model numbers updated Updated Table 4: Battery System General Specification (Changed "Storage Humidity" to "Humidity")	8,19,21,24,29 14
0.41	2020.08.11	Edited for end customer Removed "confidential" in the document header	

Table of Contents

- Revision History.....2**
- Table of Contents.....3**
- Tables.....4**
- Figures.....5**
- Acronyms and Abbreviations.....6**
- 1. Product Overview7**
 - 1.1 Scope..... 7
- 2. Product Description.....8**
- 3. Safety Information and Handling9**
 - 3.1 Safety Symbols 9
 - 3.2 General Safety Information 10
 - 3.2.1 Protective Equipment.....10
 - 3.2.2 Organic Solvent Electrolyte10
 - 3.2.3 Electrolyte Vent Product10
 - 3.2.4 High Voltage Sources.....11
 - 3.2.5 Unloading and Unpacking11
 - 3.2.6 Storage.....11
 - 3.3 General Handling Information 12
- 4. Specification and Characteristics.....13**
- 5. Block Diagram and Configuration.....17**
- 6. Detail Product Description.....18**
 - 6.1 Battery Module 18
 - 6.2 SMU..... 19
 - 6.3 SMPS Assembly 20
 - 6.4 Rack Frame..... 21
- 7. LED Indication22**
 - 7.1 Battery Status Display 22
- 8. Evaluation.....23**
- 9. Packaging and Shipment.....24**
- 10. Service, Maintenance and Warranty25**
 - 10.1 Service..... 25
 - 10.2 Maintenance 25
 - 10.3 Warranty 25
- Contact Information.....26**

Tables

Table 1: Acronyms and Abbreviations 6

Table 2: Component Information 7

Table 3: Safety Symbols 9

Table 4: Battery System General Specification 13

Table 5: 136S Battery System Specification 14

Table 6: 128S Battery System Specification 14

Table 7: 112S Battery System General Specification 15

Table 8: 104S Battery System General Specification 15

Table 9: 80S Battery System General Specification 16

Table 10: LED Indicator 22

Table 11: Indicated Codes..... 22

Table 12: List of Standards and Regulations 23

Figures

Figure 1: 34.6kWh Lithium Ion Energy Storage System..... 8
Figure 2: Storage Guide 12
Figure 3: General System Block Diagram 17
Figure 4 : Battery Module Type A 18
Figure 5 : Battery Module Type B 18
Figure 6: SMU 19
Figure 7: SMPS Assembly..... 20
Figure 8: Rack Frame 21

Acronyms and Abbreviations

The following acronyms and abbreviations are used in this manual.

Table 1: Acronyms and Abbreviations

Abbreviations	Full Name
BMS	Battery Management System
ESS	Energy Storage System
OCP	Over Current Protection
OTP	Over Temperature Protection
OVP	Over Voltage Protection
SMPS	Switching Mode Power Supply
SMU	String Management Unit
SOC	State Of Charge
SOH	State Of Health
UTP	Under Temperature Protection
UVP	Under Voltage Protection
UPS	Uninterruptible Power Supply

1. Product Overview

Customer:

Model Number:

PHR3462-001A (136S), PHR3262-001A (128S), PHR2852-001A (112S), PHR2652-001A (104S), PHR2042-001A (80S)

Product Name: Lithium Ion Battery System for UPS

Supplier: Samsung SDI Co., Ltd.

1.1 Scope

This document details the safety and handling information, characteristics, requirements, installation instructions, operating guidelines, service, maintenance and warranty of Lithium Ion Battery System manufactured by Samsung SDI Co., Ltd. It is intended to provide certified personnel and users with information on safe handling, installation and usage of the specified product. Consult with Samsung SDI if some usages not described are expected.

This product is comprised of the following components.

Table 2: Component Information

Component	Model No.	Note
67Ah Cell	CM0630R0002A	
67Ah 8S1P Battery Module Type A	EM2031AE003A	
67Ah 8S1P Battery Module Type B	EM2031AE004A	
String Management Unit (SMU)	V049-0011AA	UL
SMPS Assembly 3 Phase Type A	V044-0006AA	3 Phase AC input, System BMS
SMPS Assembly 3 Phase Type B	SJ94-00238B	3 Phase AC input, no System BMS
SMPS Assembly 1 Phase Type A	V044-0004AA	1 Phase AC input, System BMS
SMPS Assembly 1 Phase Type B	V044-0005AA	1 Phase AC input, no System BMS
Rack Frame	V808-00068A	Black

2. Product Description

The Battery system consists of four major components: 67Ah 8S1P Battery Module (“Battery Module” hereinafter), String Management Unit (SMU) and SMPS Assembly. A single rack configuration of 34.6kWh Battery System is comprised of one SMU and one SMPS Assembly and 17 Battery Modules.

Battery Module is the most basic component of the Battery System and it contains the energy storing battery cells. There is a Module BMS inside each Battery Module. Module BMS checks the status of a Battery Module by measuring its voltage and temperature. It also communicates with the SMU to send all measured voltage and temperature data, and to receive commands to control cell balancing.

SMU collects all information about the battery system and controls the battery system by switching the main power line and controls each Battery Module by cell balancing. SMU calculates the state-of-charge (SOC) and state-of-health (SOH) of the battery system. Key components in the SMU are Rack BMS, MCCB, and shunt resistor. Rack BMS is the main controller that takes all data from the Module BMS, measures the string voltage and current, determines the state of the battery and controls the MCCB accordingly.

SMPS Assembly Type A is comprised of System BMS and switching mode power supply (SMPS). SMPS Assembly Type A supplies power to the BMS and communicates with Uninterruptible Power Supply (UPS). SMPS Assembly Type B is comprised of only SMPS which supplies power to the BMS.

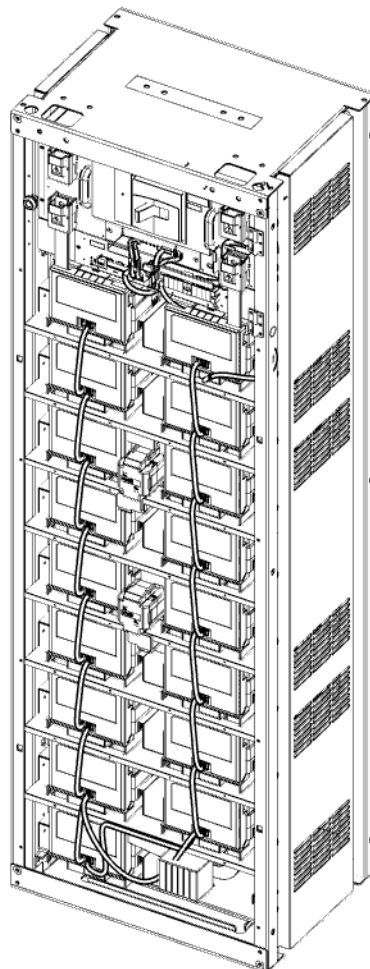











Figure 1: 34.6kWh Lithium Ion Energy Storage System



3. Safety Information and Handling

This Part details the safety information that personnel must fully understand and follow while transporting, storing, installing, operating or servicing the Battery System. Before proceeding with unloading, unpacking, handling, installation and operation, read the following details.

3.1 Safety Symbols

Table 3: Safety Symbols

 <p>DANGER</p>	<p>DANGER 'DANGER' indicates a hazardous situation which will result in death or serious injury if not avoided.</p>
 <p>WARNING</p>	<p>WARNING 'WARNING' indicates a hazardous situation which could result in death or serious injury if not avoided.</p>
 <p>CAUTION</p>	<p>CAUTION 'CAUTION' indicates a hazardous situation which could result in minor or moderate injury if not avoided.</p>
 <p>NOTICE</p>	<p>NOTICE 'NOTICE' indicates a hazardous situation which could result in property damage if not avoided.</p>
	<p>Energy Storage Device To help avoid burns or electric shock : - Service by qualified personnel only - Disconnect main power before maintenance - Turn off the Battery System before maintenance</p>
	<p>Electric shock hazard Do not remove cover or disassemble.</p>
	<p>Explosive gas Do not expose to flame, incinerate, puncture, or impact</p>
	<p>Shield eyes Wear safety goggles at ALL times. (Installation, maintenance, etc.)</p>
	<p>Electrolyte hazard Do not contact eyes, skin or clothing. If it happens, Flush with water and seek medical aid immediately.</p>
	<p>Do not dispose in trash Transport legally. Follow manufacturer's instructions for disposal. Please recycle Lithium ion battery. Do not discard.</p>

	<p>Qualified technicians use this manual for service and replacement.</p>
	<p>This symbol is attached to the position near the DC+, DC- and communication port. If the user wants to access to the points near this symbol, he has to be fully aware of the contents in this manual.</p>
	<p>This symbol is near to the point for grounding. Wire for grounding has to be connected to the point with this symbol.</p>

3.2 General Safety Information

The Battery System provides a safe source of electrical energy when operated as intended and as designed. Potentially hazardous circumstances such as excessive heat or electrolyte mist may occur under improper operating conditions, damage, misuse and/or abuse. The following safety precautions and the warning messages described in this Part must be observed.

If any of the following precautions are not fully understood, or if you have any questions, contact Customer Support for guidance. The Safety Part may not include all regulations for your locale; personnel working with the Battery System must review applicable federal, state and local regulations as well as the industry standards regarding this product.

3.2.1 Protective Equipment

When working with the Battery System, the following personal protective equipment must be worn:

- High voltage rated rubber gloves
- Safety goggles or other eye protection

3.2.2 Organic Solvent Electrolyte

Cell components of the Battery System contain organic solvent-based electrolyte. Breach of individual cells may allow some electrolyte to be released from the cell. Direct contact with the liquid electrolyte can cause skin irritation.

If contact with the liquid electrolyte occurs, follow the suggestions below to minimize the chance of injury:

- Flush eyes immediately with cold running water for at least 15 minutes.
- Rinse skin immediately with water for at least 15 minutes.
- Remove clothing if soiled.
- Seek immediate medical attention.

3.2.3 Electrolyte Vent Product

The Lithium-Ion chemistry used in the Battery System contains an organic solvent-based electrolyte. If the Battery System is misused, damaged or abused, internal cell pressure may increase to excessive levels. Each

cell within the Battery System is equipped with a non-resettable vent so that if internal cell pressure increases, the cell's vent will activate releasing the electrolyte vent products. When operated as intended and designed, internal cell pressure remains stable and no electrolyte product venting occurs. Other structure (rack, enclosure e.g.) must not interfere gas vent.

Organic solvent electrolyte vent products are flammable. To avoid serious injury from the release and ignition of flammable products, the following guidelines must be observed:

- Operate the Battery System under conditions only as specified in this manual.
- Keep sparks, flames and smoking materials away from the Battery System.
- Do not incinerate, puncture or impact the Battery System.
- Do not solder or weld to the Battery System.

3.2.4 High Voltage Sources



DANGER: HIGH VOLTAGE – ELECTRIC SHOCK HAZARD. The Battery System contains high voltage electric shock sources. Do NOT open any cover of Battery Module, SMU and SMPS Assembly.

DANGER Exposure to high voltage can cause serious electrical burns, shock or death. To avoid high voltage electrical shock, follow the guidelines below:

- Do not work with high voltages unless you are qualified personnel.
- Personnel must fully understand the safety precautions associated with working on high voltage circuits.
- Personnel must fully understand the risk of working with batteries, and be prepared and equipped to take the necessary safety precautions.
- Necessary equipment, including but not limited to insulated tools, high voltage rated rubber gloves, rubber aprons, safety goggles, and face protection must be used.
- Ensure that the system is powered off and disconnected from outside circuits before servicing the unit.

3.2.5 Unloading and Unpacking

Carefully remove the plastic cover from the pallet. The packages are situated on a pallet on which it can be transported via forklift from location to location.

A damaged box or rattles during transport may indicate rough handling. Make a descriptive notation on the delivery receipt before signing. If damage is found, request an inspection by the carrier and file a damage claim. Pay particular attention to a damaged crate or staining from electrolyte or other fluids. Delay in notifying carrier may result in the loss of reimbursement for damages.

3.2.6 Storage

Follow the guidelines below when storing the Battery Modules.

- The battery module box should be upright as in Fig. 1 below. Do not stack or place upside down when storing the battery module box.

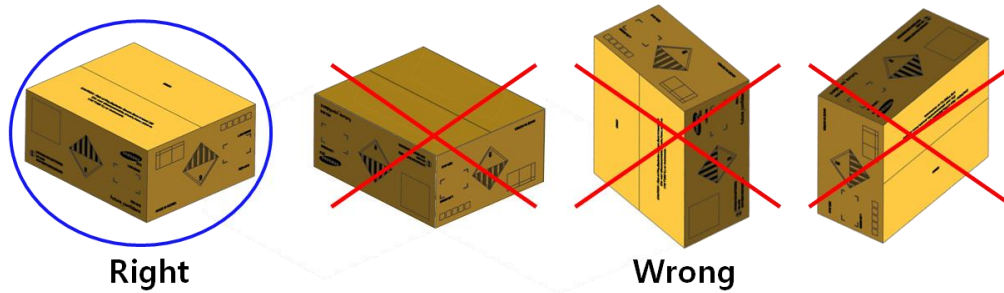

Figure 2: Storage Guide

- Do not stack more than five Battery Module boxes.
- Storage temperature must be in the range of 0 to 40°C.
- Storage humidity is recommended to be less than 60% RH under noncondensing.
- Capacity degradation will occur depending on storage time.

To minimize capacity degradation, storage temperature of less than 10°C and 3.630V per cell is recommended.

3.3 General Handling Information

Follow the guidelines below when handling the Battery System.

- Do not short circuit the positive (+) and negative (-) terminals with metallic object intentionally.
- Do not remove insulation cap on the terminals. If insulation cap is removed, avoid contacting between the metals and the battery terminals. Do not damage the screw thread.
- Do not use seriously scarred or deformed battery. Dispose them immediately according to proper regulations.
- Do not damage sheath of cable and connectors.

4. Specification and Characteristics

Table 4: Battery System General Specification

No.	Item	Specification	Remarks	
1	Dimension [mm, (inch)]	SMU	583 x 359.6 x 235.6, (22.95 x 14.16 x 9.28)	
		Battery Module	403.5 x 214 x 163, (15.89 x 8.43 x 6.42)	Type A and Type B
		SMPS Assembly 3 phase	397.4 x 355.6 x 85.5, (15.64 x 14 x 3.37)	Type A and Type B
		SMPS Assembly 1 phase	397.4 x 355.6 x 85.5, (15.64 x 14 x 3.37)	Type A and Type B
		Rack Frame	650 x 530 x 2055 (25.59 x 20.87 x 80.91)	
2	Weight [kg,(lb)]	SMU	About 18, (40)	
		Battery Module	About 16.5, (36)	Type A and Type B
		SMPS Assembly	About 5, (11)	Type A and Type B
		Rack Frame	About 163.4, (360)	
		136S Battery System	About 510, (1124)	
		128S Battery System	About 493, (1087)	
		112S Battery System	About 459, (1012)	
		104S Battery System	About 442, (974)	
80S Battery System	About 391, (862)			
3	Minimum Capacity	67Ah	1/3C (22A) charge and discharge @25°C	
4	Recommended Operation Temperature	23±5°C		
5	Maximum Operating Altitude	2,000m above sea level		
6	Storage Temperature	0 ~ 40°C		
7	Storage Humidity	Less than 90 % RH	Noncondensing	
8	Recommended Storage Humidity	Less than 60 % RH	Noncondensing	
9	Storage Period ¹	Less than 6 months		
10	Communication (Internal)	Differential UART, 2 Mbps	SMU – Battery Module	
11	Communication (External)1	RS485	UPS – SMPS Assembly	
	Communication (External)2	TCP/IP	UPS – SMPS Assembly	
	Communication (External)3	Dry contact	UPS – SMPS Assembly	

¹ The Capacity degradation will occur depending on storage time.

- To minimize capacity degradation, storage temperature of less than 10°C and 3.630V per cell is recommended.

Table 5: 136S Battery System Specification

No.	Item	Specification	Remarks
1	Number of Module	17	8 Type A 9 Type B
2	Nominal Capacity	34.6kWh	1/3C @25°C
3	Nominal Voltage ¹	516.8V DC	3.8V/cell
4	Maximum Voltage ¹	571.2V DC	4.2V/cell
5	Discharging Method	Constant Power	
	End of Discharge Voltage ¹	408V DC	3.0V/cell
	Recommended End of Discharge Voltage ¹	435.2V DC	3.2V/cell
	Standard Discharging Current ¹	22.3A	1/3C @25°C
	Maximum Continuous Discharge Power ¹	183.6kW	Peak 450A @ EODV
6	Charging Method	CC-CV, Floating	
	Floating Charging Voltage ¹	571.2V DC	4.2V/cell
	Standard Charging Current ¹	22.3A	1/3C
	Maximum Peak Charging Current ¹	250A	2 second pulse
	Maximum Continuous Charging Current ¹	67A	1C

¹ Specified voltage and current must be satisfied in all load and charging conditions.



Notice: After a full discharge at maximum continuous discharge power, cool the battery for at least 12 hours before another discharge in order to avoid over-temperature protection. Immediate recharging is allowed with standard charging current. For optimal performance, wait until the battery temperature returns to at least ±3°C within the room temperature.

Table 6: 128S Battery System Specification

No.	Item	Specification	Remarks
1	Number of Module	16	8 Type A 8 Type B
2	Nominal Capacity	32.6kWh	1/3C@R.T
3	Nominal Voltage ¹	486.4V DC	3.8V/cell
4	Maximum Voltage ¹	537.6V DC	4.2V/cell
5	Discharging Method	Constant Power	
	End of Discharge Voltage ¹	384V DC	3.0V/cell
	Recommended End of Discharge Voltage ¹	409.6V DC	3.2V/cell
	Standard Discharging Current ¹	22.3A	1/3C@R.T
	Maximum Continuous Discharge Power ¹	173kW	Peak 450A @ EODV
6	Charging Method	CC-CV, Floating	
	Floating Charging Voltage ¹	537.6V DC	4.2V/cell
	Standard Charging Current ¹	22.3A	1/3C
	Maximum Peak Charging Current ¹	250A	2 second pulse
	Maximum Continuous Charging Current ¹	67A	1C

¹ Specified voltage and current must be satisfied in all load and charging conditions.



Notice: After a full discharge at maximum continuous discharge power, cool the battery for at least 12 hours before another discharge in order to avoid over-temperature protection. Immediate recharging is allowed with standard charging current. For optimal performance, wait until the battery temperature returns to at least ±3°C within the room temperature.

Table 7: 112S Battery System General Specification

No.	Item	Specification	Remarks
1	Number of Module	14	6 Type A 8 Type B
2	Nominal Capacity	28.5kWh	1/3C@R.T
3	Nominal Voltage ¹	425.6V DC	3.8V/cell
4	Maximum Voltage ¹	470.4V DC	4.2V/cell
5	Discharging Method	Constant Power	
	End of Discharge Voltage ¹	336V DC	3.0V/cell
	Recommended End of Discharge Voltage ¹	358.4V DC	3.2V/cell
	Standard Discharging Current ¹	22.3A	1/3C@R.T
	Maximum Continuous Discharge Power ¹	151kW	Peak 450A @ EODV
6	Charging Method	CC-CV, Floating	
	Floating Charging Voltage ¹	470.4V DC	4.2V/cell
	Standard Charging Current ¹	22.3A	1/3C
	Maximum Peak Charging Current ¹	250A	2 second pulse
	Maximum Continuous Charging Current ¹	67A	1C

¹ Specified voltage and current must be satisfied in all load and charging conditions.



Notice: After a full discharge at maximum continuous discharge power, cool the battery for at least 12 hours before another discharge in order to avoid over-temperature protection. Immediate recharging is allowed with standard charging current. For optimal performance, wait until the battery temperature returns to at least $\pm 3^{\circ}\text{C}$ within the room temperature.

Table 8: 104S Battery System General Specification

No.	Item	Specification	Remarks
1	Number of Module	13	6 Type A 7 Type B
2	Nominal Capacity	26.5kWh	1/3C@R.T
3	Nominal Voltage ¹	395.2V DC	3.8V/cell
4	Maximum Voltage ¹	436.8V DC	4.2V/cell
5	Discharging Method	Constant Power	
	End of Discharge Voltage ¹	312V DC	3.0V/cell
	Recommended End of Discharge Voltage ¹	332.8V DC	3.2V/cell
	Standard Discharging Current ¹	22.3A	1/3C@R.T
	Maximum Continuous Discharge Power ¹	140kW	Peak 450A @ EODV
6	Charging Method	CC-CV, Floating	
	Floating Charging Voltage ¹	436.8V DC	4.2V/cell
	Standard Charging Current ¹	22.3A	1/3C
	Maximum Peak Charging Current ¹	250A	2 second pulse
	Maximum Continuous Charging Current ¹	67A	1C

¹ Specified voltage and current must be satisfied in all load and charging conditions.



Notice: After a full discharge at maximum continuous discharge power, cool the battery for at least 12 hours before another discharge in order to avoid over-temperature protection. Immediate recharging is allowed with standard charging current. For optimal performance, wait until the battery temperature returns to at least $\pm 3^{\circ}\text{C}$ within the room temperature.

Table 9: 80S Battery System General Specification

No.	Item	Specification	Remarks
1	Number of Module	10	4 Type A 6 Type B
2	Nominal Capacity	20.4kWh	1/3C@R.T
3	Nominal Voltage ¹	304V DC	3.8V/cell
4	Maximum Voltage ¹	336V DC	4.2V/cell
5	Discharging Method	Constant Power	
	End of Discharge Voltage ¹	240V DC	3.0V/cell
	Recommended End of Discharge Voltage ¹	256V DC	3.2V/cell
	Standard Discharging Current ¹	22.3A	1/3C@R.T
	Maximum Continuous Discharge Power ¹	108kW	Peak 450A @ EODV
6	Charging Method	CC-CV, Floating	
	Floating Charging Voltage ¹	336V DC	4.2V/cell
	Standard Charging Current ¹	22.3A	1/3C
	Maximum Peak Charging Current ¹	250A	2 second pulse
	Maximum Continuous Charging Current ¹	67A	1C

¹ Specified voltage and current must be satisfied in all load and charging conditions.



Notice: After a full discharge at maximum continuous discharge power, cool the battery for at least 12 hours before another discharge in order to avoid over-temperature protection. Immediate recharging is allowed with standard charging current. For optimal performance, wait until the battery temperature returns to at least $\pm 3^{\circ}\text{C}$ within the room temperature.

5. Block Diagram and Configuration

A single rack system consists of 1 SMU, 1 SMPS Assembly and Battery Modules ranging from 10 modules (20.4kWh) to 17 modules (34.6kWh).

Refer to Figure 3: General System Block Diagram.

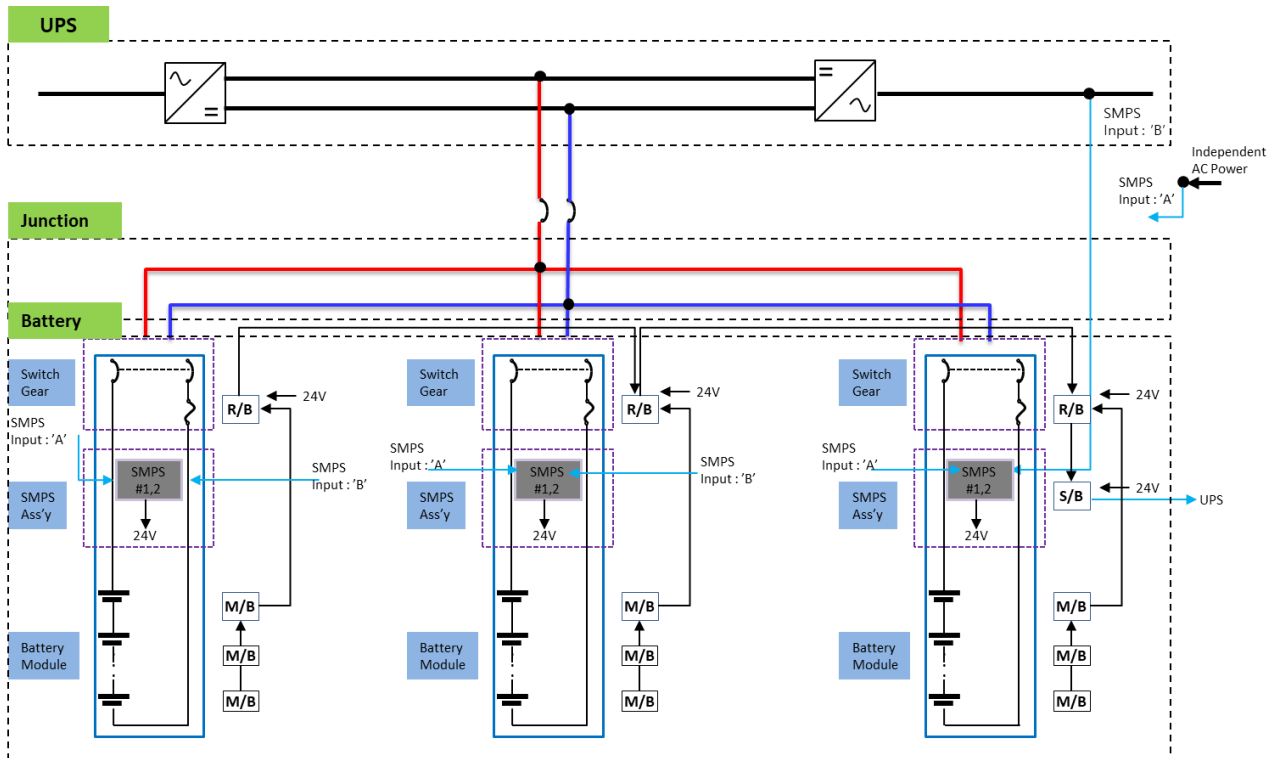

Figure 3: General System Block Diagram

6. Detail Product Description

6.1 Battery Module

Type A: EM2031AE003A

Type B: EM2031AE004A

There are two types of 8S1P Battery Module depending on the position of terminal's polarity. Type A's plus(+) terminal is on the right side. Type B is on the left.

- Nominal capacity: 67 Ah
- Nominal voltage: 30.40 V

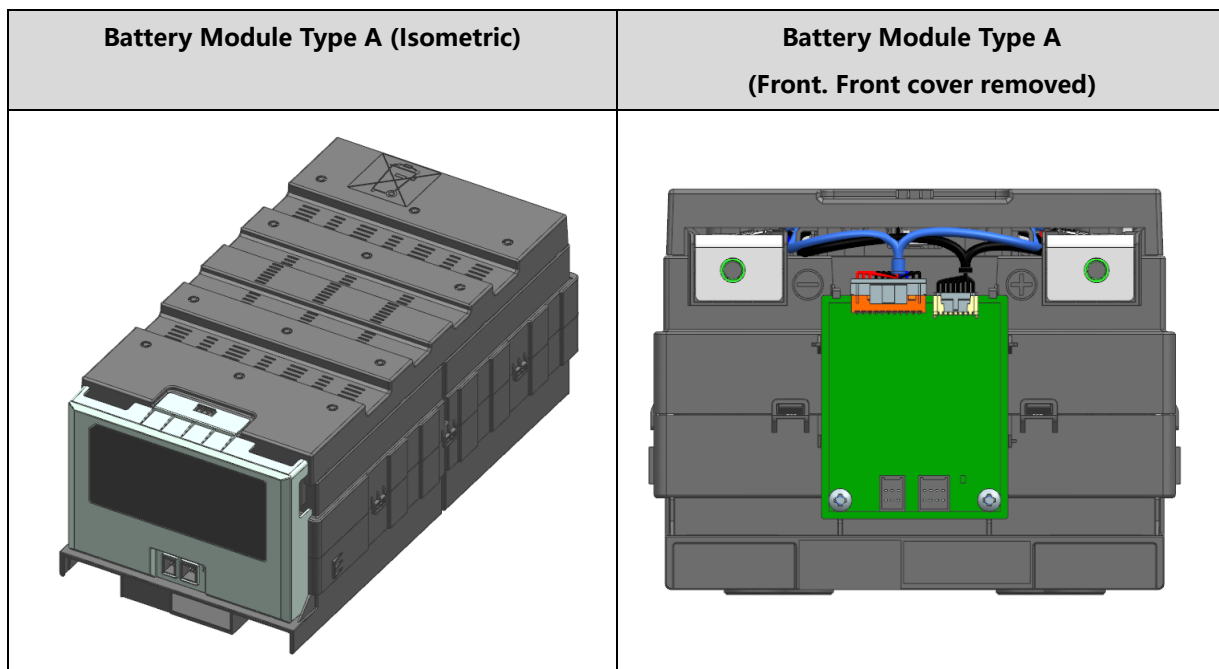

Figure 4 : Battery Module Type A

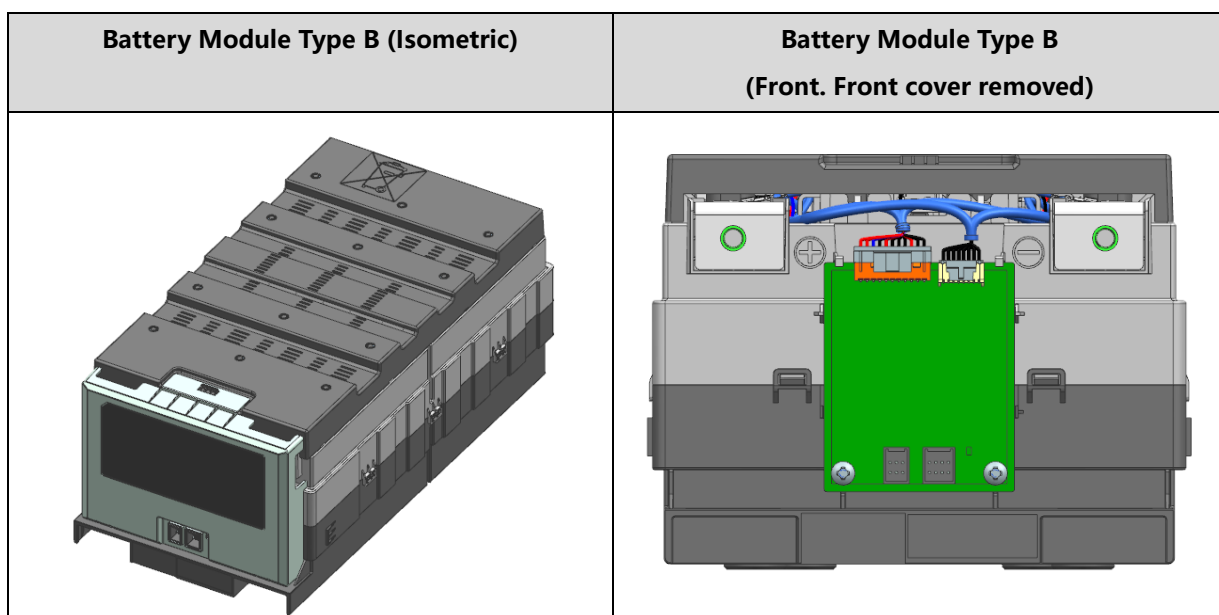

Figure 5 : Battery Module Type B

6.2 SMU

UL: V049-0011AA

The SMU consists of protection devices and a rack BMS. The key component of protection devices are as follows

- Fuse: 500A rating
- MCCB UL/CE: 600A rating

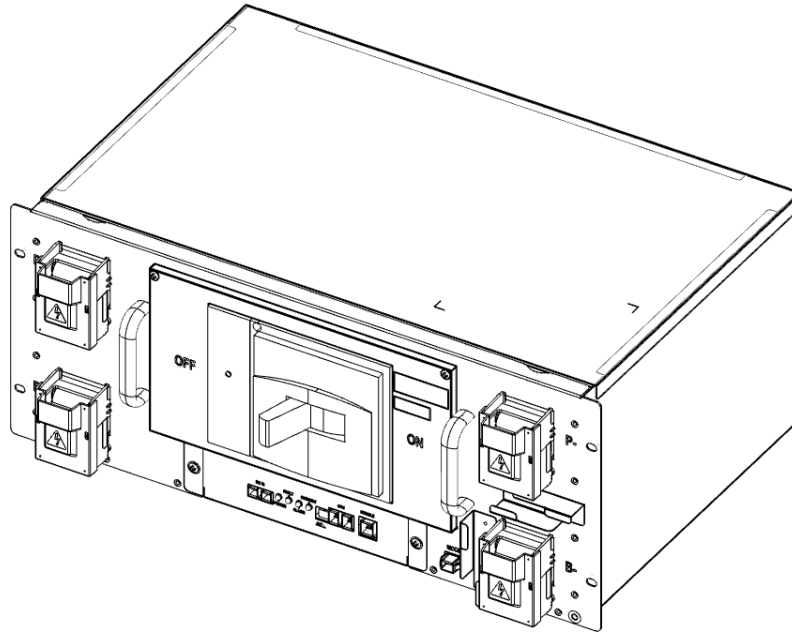

Figure 6: SMU

6.3 SMPS Assembly

- 3 Phase Type A (with System BMS): V044-0006AA
- 3 Phase Type B (without System BMS): SJ94-00238B
- 1 Phase Type A (with System BMS): V044-0004AA
- 1 Phase Type B (without System BMS): V044-0005AA

SMPS Assembly houses the System BMS and SMPS, which provides power to the System BMS and SMU. Two options are available for the SMPS depending on the AC input range and cabling: 3 phase and 1 phase. The System BMS assembly provides data to the external systems (i.e. building management system, UPS, etc.) while controlling and monitoring all connected Rack BMS.

There are two types of SMPS Assembly: Type A is with System BMS and Type B is without System BMS.

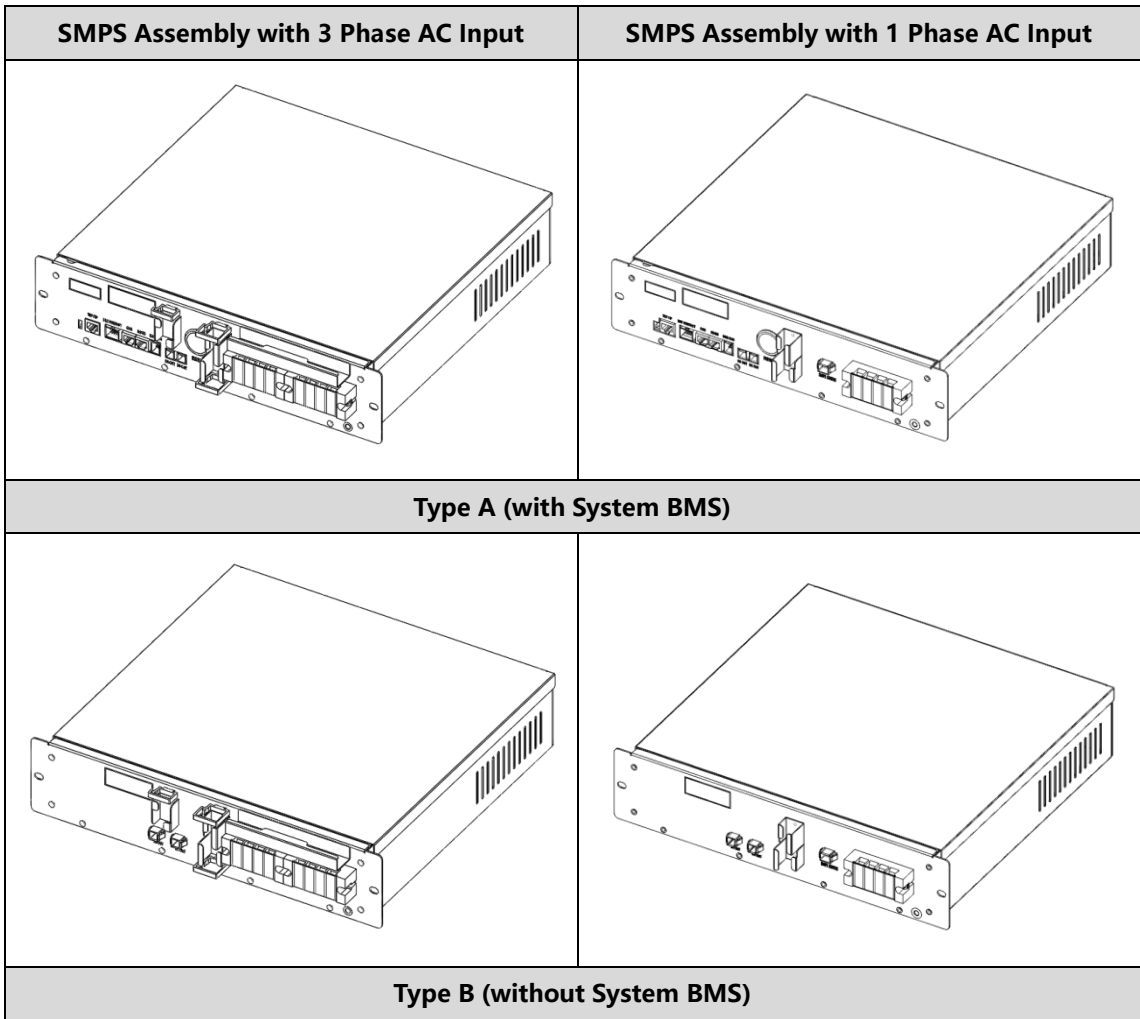

Figure 7: SMPS Assembly

6.4 Rack Frame

Black: V808-00068A

The Rack Frame is used to mount the modules, SMU and SMPS Assembly and provides ground connections for SMU and SMPS Assembly.

(Grounding cable/bus bar for the rack frame is necessary for the SMU and SMPS assembly as they are grounded to the rack frame when installed.)

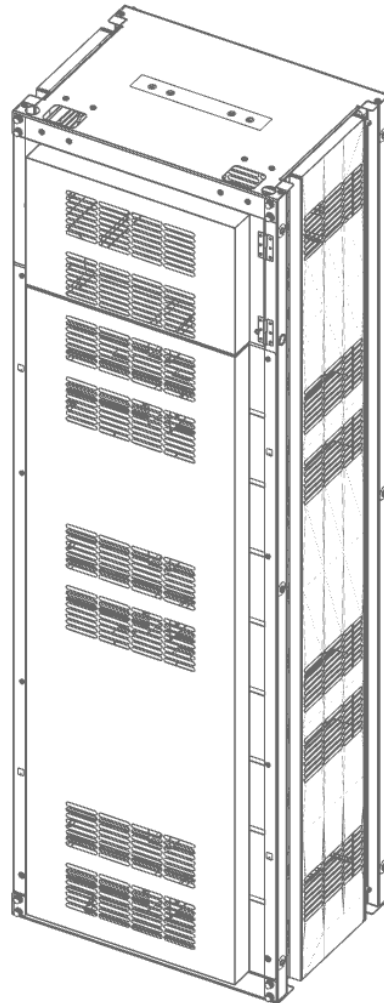

Figure 8: Rack Frame

7. LED Indication

LED indicator in front of the SMU shows the status of the battery.

7.1 Battery Status Display

The LED shows several battery conditions.

Table 10: LED Indicator



Items	POWER(Green)	FAULT(Red)	ALARM(Yellow)	CURRENT(Green)
Location				
Status	On : MCCB Off Off : Power Off Blink : MCCB On	On : N/A Off : Power Off Blink : Major Protection	On : N/A Off : Power Off Blink : Minor Protection	On : Discharge Off : Idle Blink : Charge

Table 11: Indicated Codes

LED Status	Battery Status	Remarks
 POWER steady	Normal status	MCCB Off
 POWER blinking	Normal status	MCCB On
 POWER blinking CURRENT steady	Normal Status	Discharge
 POWER blinking CURRENT blinking	Normal Status	Charge
 POWER steady FAULT blinking	Major Protection MCCB tripped	
 POWER blinking ALARM blinking	Minor Protection MCCB on	

8. Evaluation

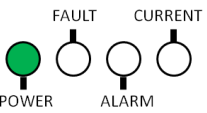
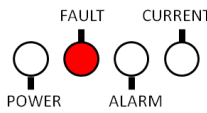
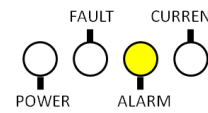
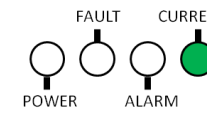
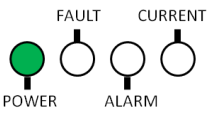
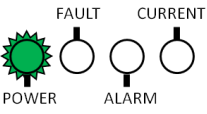
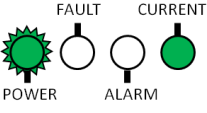
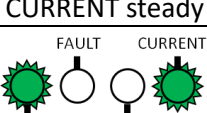
This part lists all regulation and safety tests conducted by Samsung SDI or a third-party organization. Refer to additional report for more information on test specification.

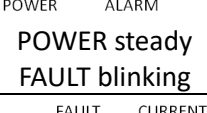
Table 12: List of Standards and Regulations

No.	Regulation	Tested Product	Result
1	UL1642	Cell	OK
2	UN38.3	Cell, 8S1P Module	OK
3	UL1973, UL991, UL1998	8S1P Module, System	OK
4	CE (IEC 62477-1, EN 61000), IEC 62619	8S1P Module, System	OK

※ Other evaluations are based on customer requirements or Samsung SDI's standards.

9. Packaging and Shipment

The Battery System is packaged in groups of each component. Refer to additional specification document on packaging and shipment details.

10. Service, Maintenance and Warranty

10.1 Service

There are no user serviceable parts in the Battery Module, SMU and SMPS Assembly. Written authorization from Samsung SDI is required to open the Battery Module, SMU and SMPS assembly or perform any maintenance thereon. For service inquiries and questions please contact Samsung SDI.

10.2 Maintenance

The Battery System is designed to be free of maintenance when the recommended operating parameters are followed.

10.3 Warranty

Do not disassemble the Battery Modules, SMU and SMPS Assembly as doing so presents a safety hazard and will void the warranty. Contact Samsung SDI for more information. Refer to the purchase agreement for warranty details.

Contact Information

Corporate Headquarters

Samsung SDI, Co. Ltd.
150-20, Gongse-ro, Giheung-gu, Yongin-si, Gyeonggi-do
Republic of Korea
Telephone: 82-31-8006-3336
Homepage: www.samsungsdi.com