



NetSure™ 7100 -48 VDC Power System

Installation Manual

Specification Number: 582127000600, 582127000601, 582127000900, 582127000901, 582127000930, 582127000931
Model Number: 7100

The information contained in this document is subject to change without notice and may not be suitable for all applications. While every precaution has been taken to ensure the accuracy and completeness of this document, Vertiv assumes no responsibility and disclaims all liability for damages resulting from use of this information or for any errors or omissions. Refer to other local practices or building codes as applicable for the correct methods, tools, and materials to be used in performing procedures not specifically described in this document.

The products covered by this instruction manual are manufactured and/or sold by Vertiv. This document is the property of Vertiv and contains confidential and proprietary information owned by Vertiv. Any copying, use or disclosure of it without the written permission of Vertiv is strictly prohibited.

Names of companies and products are trademarks or registered trademarks of the respective companies. Any questions regarding usage of trademark names should be directed to the original manufacturer.

Technical Support Site

If you encounter any installation or operational issues with your product, check the pertinent section of this manual to see if the issue can be resolved by following outlined procedures.

Visit <https://www.vertiv.com/en-us/support/> for additional assistance.

TABLE OF CONTENTS

Admonishments Used in this Document	v
Important Safety Instructions	vi
Safety Admonishments Definitions.....	vi
Safety and Regulatory Statements.....	vi
Déclarations de Sécurité et de Réglementation.....	vi
1 Customer Documentation Package	1
2 Installation Acceptance Checklist	1
3 Installing the System	3
3.1 General Requirements.....	3
3.2 Mounting the System in an Equipment Rack.....	3
3.3 Installing Optional Lug Adapter Busbar Kits.....	5
3.4 Installing Optional EIB (Controller Extended Interface Board).....	6
3.5 Installing Optional Second IB2 (Interface Board).....	9
3.6 Installing Circuit Breakers and Fuses.....	11
4 Setting Jumper and Switch Options	14
4.1 Location of Circuit Cards with Jumper and Switch Options.....	14
4.2 Jumper Settings on the System Interface Circuit Card.....	15
4.3 Switch Settings on the IB2 (Controller Interface Board).....	17
4.4 Switch Settings on Optional EIB (Controller Extended Interface Board).....	18
5 Making Electrical Connections	19
5.1 Important Safety Instructions.....	19
5.2 Wiring Considerations.....	19
5.3 Relay Rack / Equipment Cabinet Frame Grounding Connection.....	19
5.4 Power System Shelf Frame Grounding Connection.....	20
5.5 Central Office Ground Connection.....	20
5.6 AC Input and Equipment Grounding Connections (Nominal 208 VAC, 240 VAC, 277 VAC, Single Phase).....	21
5.7 External Alarm, Reference, Monitoring, and Control Connections.....	24
5.7.1 Location of Circuit Cards with External Alarm, Reference, Monitoring, and Control Connectors.....	24
5.7.2 System Interface Circuit Card Connections (if required).....	26
5.7.3 IB2 (Controller Interface Board) Connections (if required).....	29
5.7.4 Optional EIB (Controller Extended Interface Board) Connections (if required).....	34
5.8 NCU Controller Ethernet Connection (if required).....	39
5.9 Load Connections.....	41
5.9.1 Load Connections to Distribution Panels and Load Return Busbars.....	41
5.9.2 Load Connections to an Optional Bullet Nose 6-Position GMT Distribution Fuse Block, P/N 549017.....	45
5.9.3 Load Connections to an Optional 6-Position 30A GMT Fuse Kit, P/N 60160806.....	46
5.10 Battery Connections.....	47
6 Installing Rectifier or Converter Modules	49
7 Initially Starting, Configuring, and Checking System Operation	51
7.1 Important Safety Instructions.....	51
7.2 Initial Startup Preparation.....	51
7.3 Initially Starting the System.....	51

7.4	NCU Controller Initialization.....	51
7.5	Verifying and Setting the NCU Controller as Required for Your Application.....	53
7.6	Checking System Status.....	56
7.7	Final Steps.....	56

Admonishments Used in this Document



DANGER! Warns of a hazard the reader **will** be exposed to that will **likely** result in death or serious injury if not avoided. (ANSI, OSHA)



WARNING! Warns of a potential hazard the reader **may** be exposed to that **could** result in death or serious injury if not avoided. This admonition is not used for situations that pose a risk only to equipment, software, data, or service. (ANSI)



CAUTION! Warns of a potential hazard the reader **may** be exposed to that **could** result in minor or moderate injury if not avoided. (ANSI, OSHA) This admonition is not used for situations that pose a risk only to equipment, data, or service, even if such use appears to be permitted in some of the applicable standards. (OSHA)



ALERT! Alerts the reader to an action that **must be avoided** in order to protect equipment, software, data, or service. (ISO)



ALERT! Alerts the reader to an action that **must be performed** in order to prevent equipment damage, software corruption, data loss, or service interruption. (ISO)



FIRE SAFETY! Informs the reader of fire safety information, reminders, precautions, or policies, or of the locations of fire-fighting and fire-safety equipment. (ISO)



SAFETY! Informs the reader of general safety information, reminders, precautions, or policies not related to a particular source of hazard or to fire safety. (ISO, ANSI, OSHA)

Important Safety Instructions

Safety Admonishments Definitions

Definitions of the safety admonishments used in this document are listed under “Admonishments Used in this Document” on page v.

Safety and Regulatory Statements

Refer to Section 4154 (provided with your customer documentation) for Safety and Regulatory Statements.

Déclarations de Sécurité et de Réglementation

Reportez-vous à la Section 4154 (fourni avec les documents de votre client) pour les déclarations de sécurité et de réglementation.

1 Customer Documentation Package

This document (IM582127000900) provides *Installation Instructions* for Vertiv™ NetSure™ 7100 -48 VDC Power System, Spec. No. 582127000; Lists 600, 601, 900, 901, 930, and 931 only.

The complete Customer Documentation Package for Lists 600, 601, 900, 901, 930, and 931 consists of...

-48 VDC Power System Installation Manual

- Power System Installation Instructions: IM582127000900

-48 VDC Power System User Manual

- Power System User Instructions: UM582127000900

NCU Controller User Manual

- NCU Controller User Instructions: UM1M830BNA

USB Drive with All Customer Documentation

Applicable documents for this system are as follows.

- Power System Installation Instructions: IM582127000900 (instructions for Lists 600, 601, 900, 901, 930, and 931)
- Power System User Instructions: UM582127000900 (instructions for Lists 600, 601, 900, 901, 930, and 931)
- NCU Controller User Instructions: UM1M830BNA
- Rectifier Instructions: UM1R483500e3
- Power System "System Application Guide": SAG582127000
- Engineering Drawings
- Also, provided on the USB drive is a controller configuration drawing and the controller configuration files loaded into the controller as shipped.

2 Installation Acceptance Checklist

Provided in this section is an Installation Acceptance Checklist. This checklist helps ensure proper installation and initial operation of the system. As the procedures presented in this document are completed, check the appropriate box on this list. If the procedure is not required to be performed for your installation site, also check the box in this list to indicate that the procedure was read. When installation is done, ensure that each block in this list has been checked. Some of these procedures may have been factory performed for you.



NOTE! *The system is not powered up until the end of this checklist.*



NOTE! *Some of these procedures may have been performed at the factory for you.*

Installing the System

- System Secured to the Equipment Rack
- Optional Lug Adapter Busbar Kits Installed (if required)
- Circuit Breakers Installed (if required)
- Fuses Installed (if required)

Setting Jumper and Switch Options

- Jumper on System Interface Circuit Card Set
- Factory Switch Setting on IB2 (Controller Interface Board) Verified
- Factory Switch Setting on Optional EIB (Controller Extended Interface Board) Verified

Making Electrical Connections

- System Frame Ground Connection Made
- Central Office Ground Connection Made
- AC Input and AC Input Equipment Grounding Connections Made
- External Alarm, Reference, Monitoring, and Control Connections Made
- NCU Controller Ethernet Port Connection Made (if required)
- NCU Controller Second Ethernet Port Connection Made (if required)
- Load Connections Made
- Battery Connections Made

Installing Rectifier Modules

- Rectifier Modules Installed

Initially Starting the System

- System Started, Configured, and Checked

3 Installing the System

3.1 General Requirements

- This product is intended only for installation in a restricted access location on or above a non-combustible surface.
- This product must be located in a controlled environment with access to crafts persons only.
- This product is intended for installation in network telecommunication facilities (CO, vault, hut, or other environmentally controlled electronic equipment enclosure).
- This product is intended for connection to the common bonding network in a network telecommunication facility (CO, vault, hut, or other environmentally controlled electronic equipment enclosure).
- The DC return connection to this system can remain isolated from system frame and chassis (DC-I).
- The installer should be familiar with the installation requirements and techniques to be used in securing the system to an equipment rack.
- The system must be mounted in an environment that does not exceed the rated operating ambient temperature range found in SAG582127000.
- Clearance Requirements:
 - Recommended minimum clearance for the front of the system is 2' 6".
 - Recommended minimum clearance for the rear of the system is 2' 0".

3.2 Mounting the System in an Equipment Rack

This power system is designed to mount in a 23-inch wide or 27-inch wide rack having 1-inch or 1-3/4-inch multiple drillings. Refer to System Application Guide SAG582127000 for overall dimensions. Perform the following steps to mount the power system.



DANGER! The power system is heavy. Use a hoist, battery lift, or other appropriate lifting device to raise and support the power system during the installation. Take appropriate precautions to avoid injury.



NOTE! Refer to “General Requirements” on page 3 for mounting restrictions and ventilation requirements.



NOTE! The power system consists of a distribution cabinet and module mounting assemblies. The distribution cabinet is factory connected to the module mounting assemblies. The distribution cabinet with module mounting assemblies is mounted as a complete assembly.

Procedure

1. Position the power system in the equipment rack.



NOTE! In the next steps, install (orient) the ground washers so the teeth dig into the mounting angles for a secure ground connection.



NOTE! Compliance with Telcordia GR-1089-CORE requires that prior to mounting the system to the equipment rack:

- All paint must be removed from the front surface of each equipment rack rail where it mates with a shelf-mounting bracket, so that good metal-to-metal contact can be established between the shelf and rack.
- The shelf-to-rack mating surfaces must be cleaned.
- Electrical anti-oxidizing compound must be applied to the shelf-to-rack mating surfaces.

2. Secure the power system to the equipment rack using hardware as shown in Figure 3.1. Use grounding washers at all locations. Torque connections to the value indicated in Figure 3.1.

Figure 3.1: Mounting the Power System in an Equipment Rack

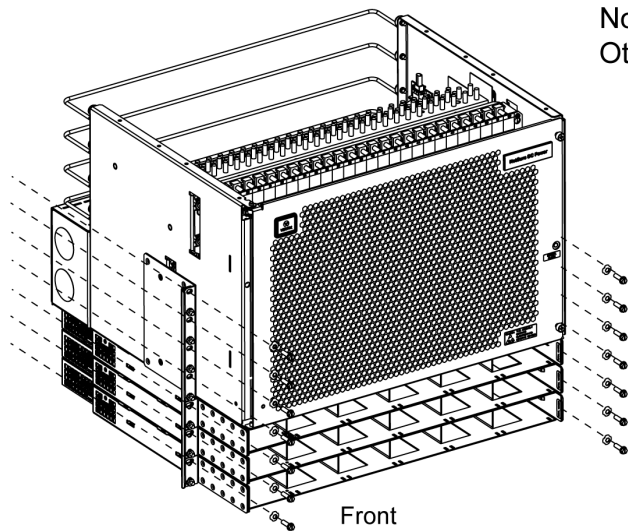

Note: List 900 is shown.
Other Lists are similar.

MOUNTING HARDWARE

12-24 x 3/4" Thread Forming Hex Head Screw

No. 10/12 Ground Washer

Torque: 65 in-lbs.

3.3 Installing Optional Lug Adapter Busbar Kits

These kits provide lug adapter busbars plus hardware for use with 2-pole, 3-pole, and 4-pole circuit breakers. A right-angle kit is also available for 1-pole devices.

Procedure

1. Refer to Figure 3.2 to install the lug adapter busbars kits.

Figure 3.2: Installing Optional Lug Adapter Busbar Kits

Apply anti-oxidizing compound to busbar mating surfaces before assembling.

Recommended torque is 75 in-lbs using the supplied 1/4" bolts and hardware.

Recommended torque is 300 in-lbs using the supplied 3/8" bolts and hardware.

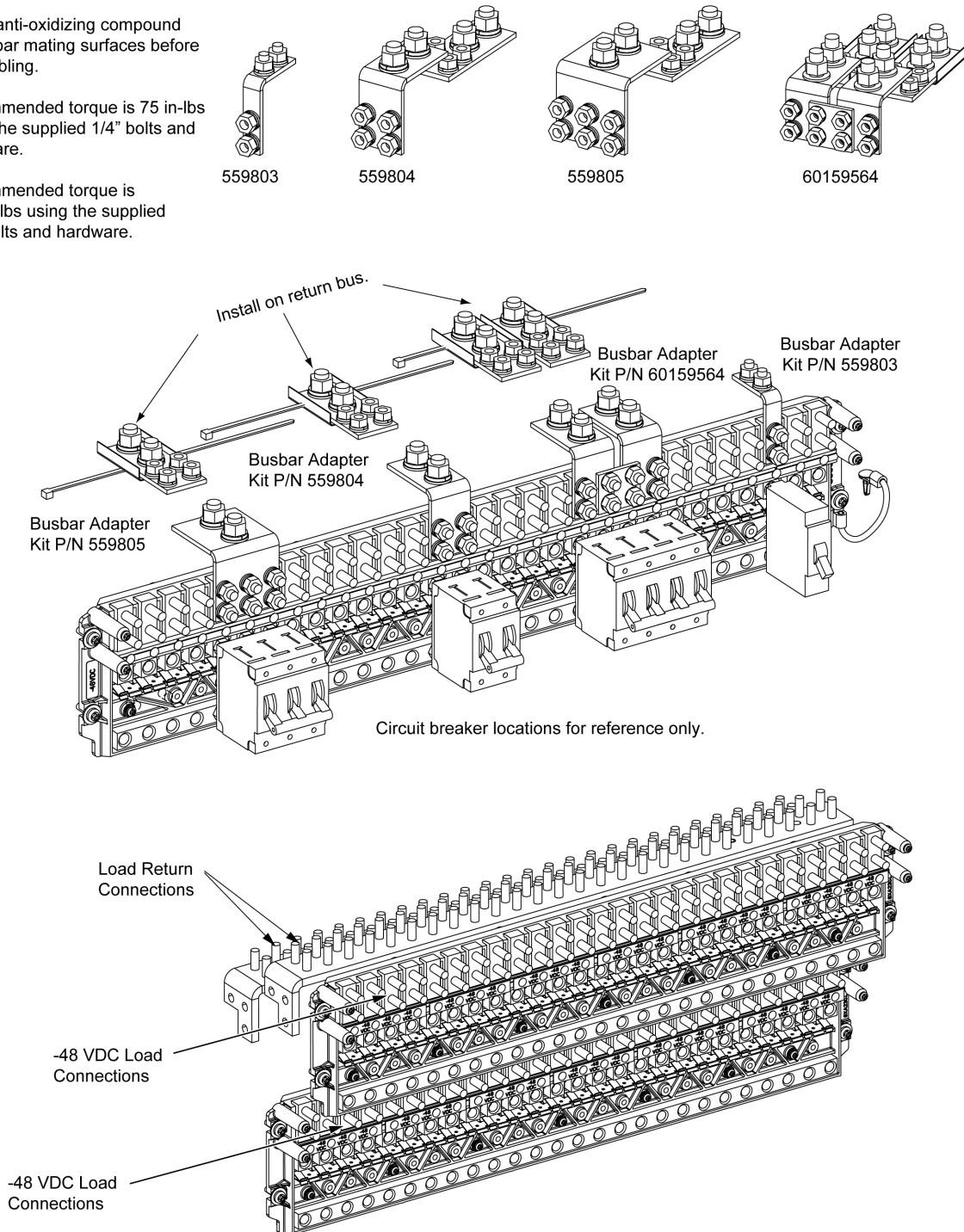

3.4 Installing Optional EIB (Controller Extended Interface Board)

An EIB (Controller Extended Interface Board) can be installed inside the distribution cabinet. This option is factory installed if ordered with the system. Refer to the following procedure to field install this option.

Procedure

1. Performing this procedure may activate external alarms. Do one of the following. If possible, disable these alarms. If these alarms cannot be easily disabled, notify the appropriate personnel to disregard any future alarms associated with this system while the procedure is being performed.



DANGER! Performing the next steps exposes service personnel to battery potential. Exercise extreme caution not to inadvertently contact or have any tool inadvertently contact any energized electrical termination.

2. Open the distribution cabinet's front door.



WARNING! Damage to the circuit card may result if the next step is not followed.

3. Connect an approved grounding strap to your wrist. Attach the other end to a suitable ground.
4. Set the switch on the EIB board as outlined in "Switch Settings on Optional EIB (Controller Extended Interface Board)" on page 18.
5. Refer to Figure 3.3 (Lists 600, 601, 900, 901) or Figure 3.4 (930, 931) and install the EIB board inside the distribution cabinet.
6. Locate the I2C connector bundled at the bottom of the distribution cabinet. Route this cable to the newly installed EIB board. Cut cable ties as required. Plug this connector into the mating I2C connector located on the EIB board. Refer to Figure 3.3 or Figure 3.4. Dress and secure the cable as required.
7. Make external connections to the EIB board as required. See "Optional EIB (Controller Extended Interface Board) Connections (if required)" on page 34.
8. Remove the grounding wrist strap.
9. Reboot the Controller
Local Menu Navigation: At the Main Screen, press ENT and ESC at the same time to reset the NCU Controller.
Web Menu Navigation: Go to Advance Settings Menu / SW Maintenance Tab / Reboot Controller button.
10. Close the distribution cabinet's front door.
11. Enable the external alarms or notify appropriate personnel that this procedure is finished.
12. Ensure that there are no local or remote alarms active on the system.

Figure 3.3: Installing Optional EIB (Controller Extended Interface Board) – Lists 600, 601, 900, 901

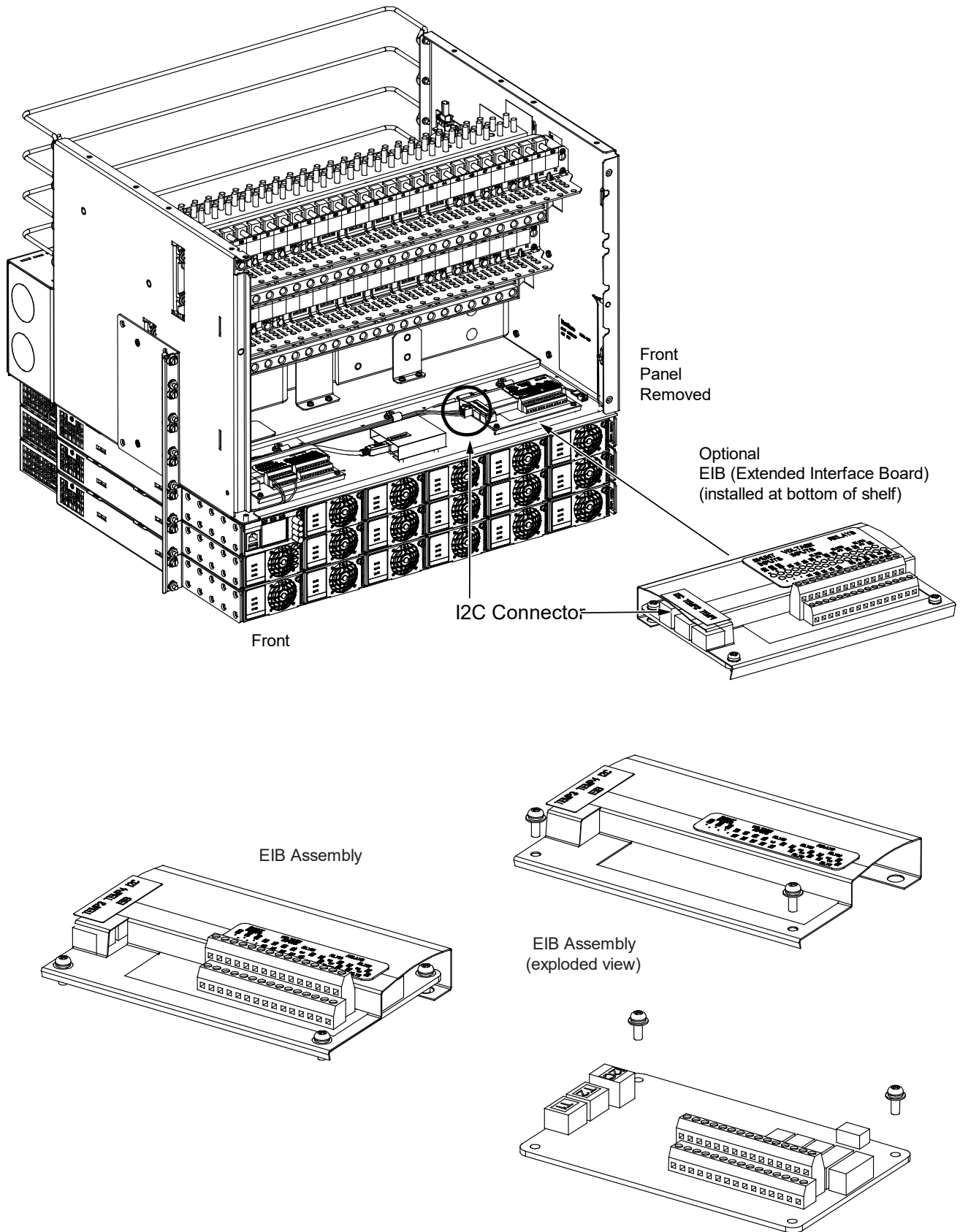
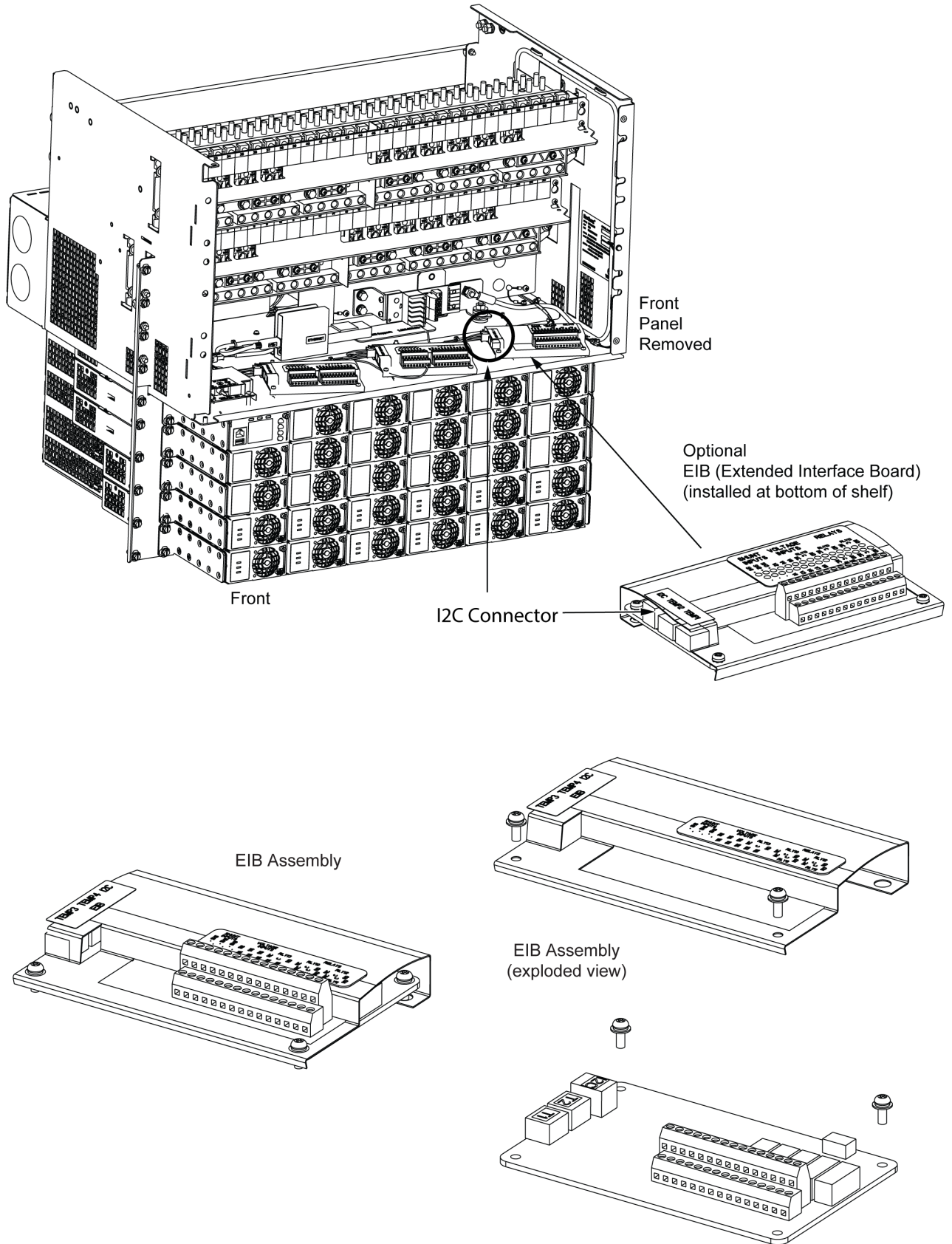

Figure 3.4: Installing Optional EIB (Controller Extended Interface Board) – Lists 930, 931



3.5 Installing Optional Second IB2 (Interface Board)

For Lists 930 and 931, a second IB2 (Interface Board) can be installed inside the distribution cabinet. This option is factory installed if ordered with the system. Refer to the following procedure to field install this option.

Procedure

1. Performing this procedure may activate external alarms. Do one of the following. If possible, disable these alarms. If these alarms cannot be easily disabled, notify the appropriate personnel to disregard any future alarms associated with this system while the procedure is being performed.



DANGER! Performing the next steps exposes service personnel to battery potential. Exercise extreme caution not to inadvertently contact or have any tool inadvertently contact any energized electrical termination.

2. Open the distribution cabinet's front door.



WARNING! Damage to the circuit card may result if the next step is not followed.

3. Connect an approved grounding strap to your wrist. Attach the other end to a suitable ground.
4. Set the switch on the IB2 board as outlined in "Switch Settings on the IB2 (Controller Interface Board)" on page 17.
5. Refer to Figure 3.5 and install the IB2 board inside the distribution cabinet.
6. Locate the I2C connector bundled at the bottom of the distribution cabinet. Route this cable to the newly installed IB2 board. Cut cable ties as required. Plug this connector into the mating I2C connector located on the IB2 board. Refer to Figure 3.5. Dress and secure the cable as required.
7. Make external connections to the IB2 board as required. See "IB2 (Controller Interface Board) Connections (if required)" on page 29.
8. Remove the grounding wrist strap.
9. Reboot the Controller
Local Menu Navigation: At the Main Screen, press ENT and ESC at the same time to reset the NCU Controller.
Web Menu Navigation: Go to Advance Settings Menu / SW Maintenance Tab / Reboot Controller button.
10. Close the distribution cabinet's front door.
11. Enable the external alarms or notify appropriate personnel that this procedure is finished.
12. Ensure that there are no local or remote alarms active on the system.

Figure 3.5: Installing Optional IB2 (Interface Board) – Lists 930, 931

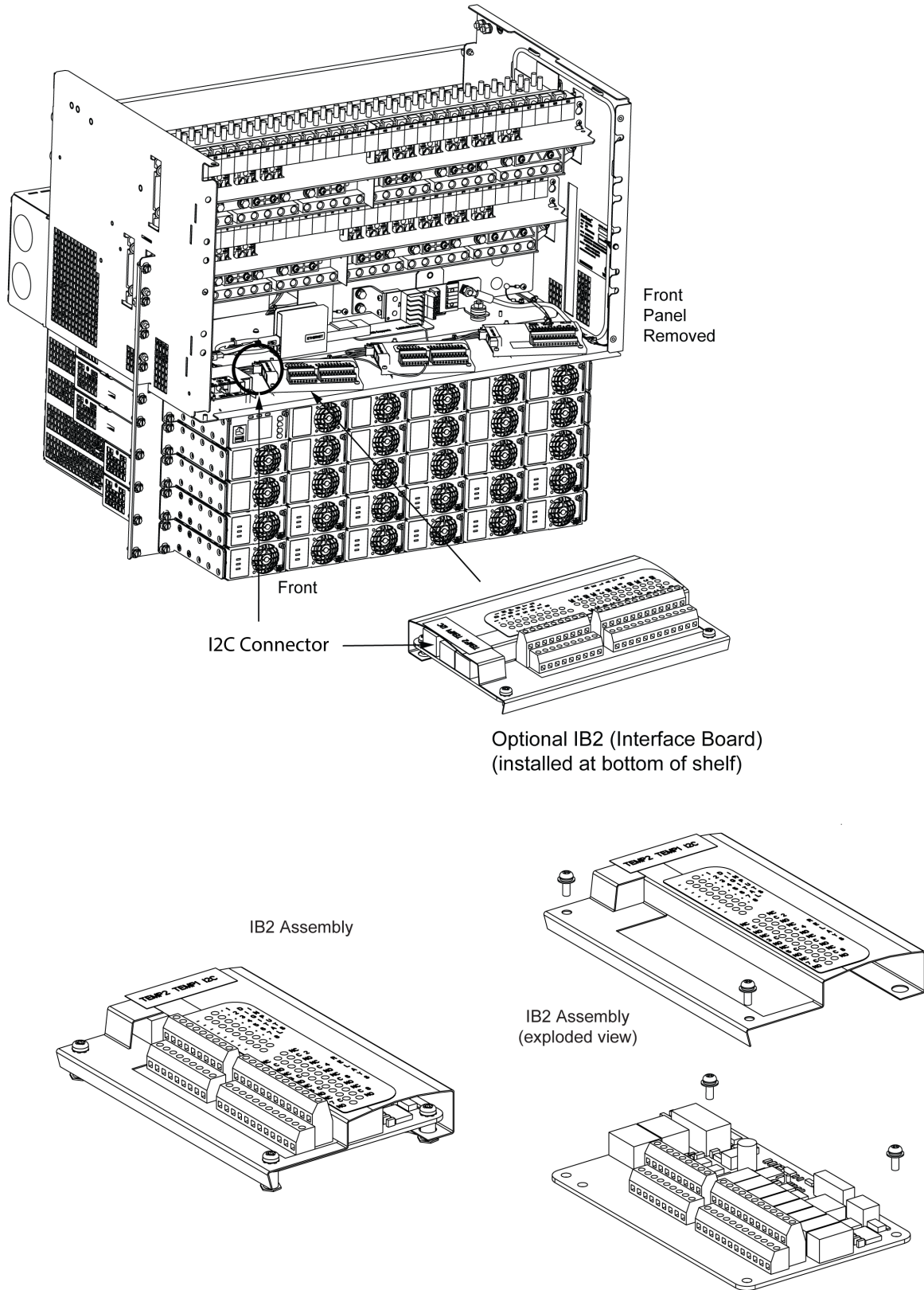

3.6 Installing Circuit Breakers and Fuses

Circuit breakers and/or fuses may have been factory installed for you. If so, verify their positions and sizes.

Installing Bullet Nose Type Circuit Breakers



CAUTION! See SAG582127000 for temperature, sizing, and spacing restrictions. Refer to SAG582127000 for any other restrictions.

Refer to the following procedure and install appropriately sized bullet nose type circuit breakers into the proper mounting positions in the distribution cabinet.

Procedure

1. Open the distribution cabinet's front door.
2. Ensure that the circuit breaker is in the OFF position and is of the correct rating. Orient the circuit breaker as shown in Figure 3.6. Insert the terminals on the rear of the circuit breaker into their corresponding sockets on the distribution panel. Ensure the alarm contact on the back of the circuit breaker makes contact with the alarm terminal on the spring strip. Push distribution device in firmly until fully seated in the distribution panel.
3. Record all circuit breaker sizes on the label provided on the shield.
4. Close and secure the distribution cabinet's front door.

Figure 3.6: Installing a Bullet Nose Type Circuit Breaker

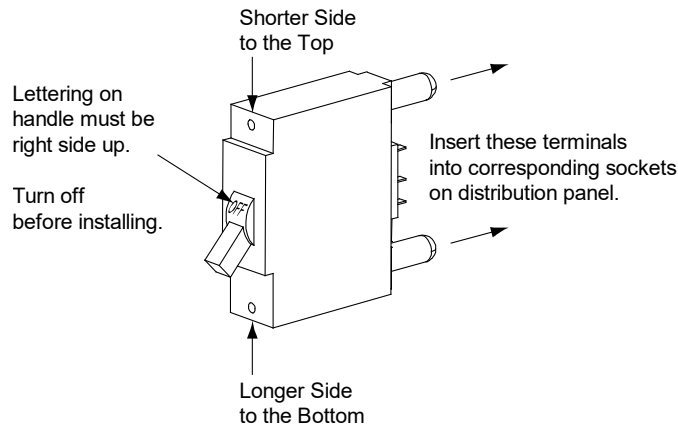

Installing Bullet Nose Type Fuseholders and TPS/TLS Fuses



CAUTION! See SAG582127000 for temperature, sizing, and spacing restrictions. Refer to SAG582127000 for any other restrictions.

Refer to the following procedure and install bullet nose type fuseholders and appropriately sized TPS/TLS fuses into the proper mounting positions in the distribution cabinet.

Procedure

1. Open the distribution cabinet's front door.
2. Orient the fuseholder as shown in Figure 3.7. Insert the terminals on the rear of the fuseholder into their corresponding sockets on the distribution panel. Ensure the alarm contact on the back of the fuseholder makes contact with the alarm terminal on the spring strip. Push fuseholder in firmly until fully seated in the distribution panel.
3. When all fuseholders are installed, install an appropriately sized TPS/TLS fuse in each. To do this, remove the fuse carrier from the mounted fuseholder body. Hold the fuseholder body while you pull the fuse carrier from the body. Slide the fuse in place between the contacts of the fuse carrier. When done, push the fuse carrier back into the fuseholder body. Note that a polarizing key on the bottom of the carrier prevents the carrier from being inserted upside down. See Figure 3.7.
4. Verify that an 18/100 ampere alarm fuse is present in each fuseholder and that a plastic safety cover is installed on this fuse.
5. Record all fuse sizes on the label provided on the shield.
6. Close and secure the distribution cabinet's front door.

Figure 3.7: Installing a Bullet Nose Type Fuseholder and TPS/TLS Fuse

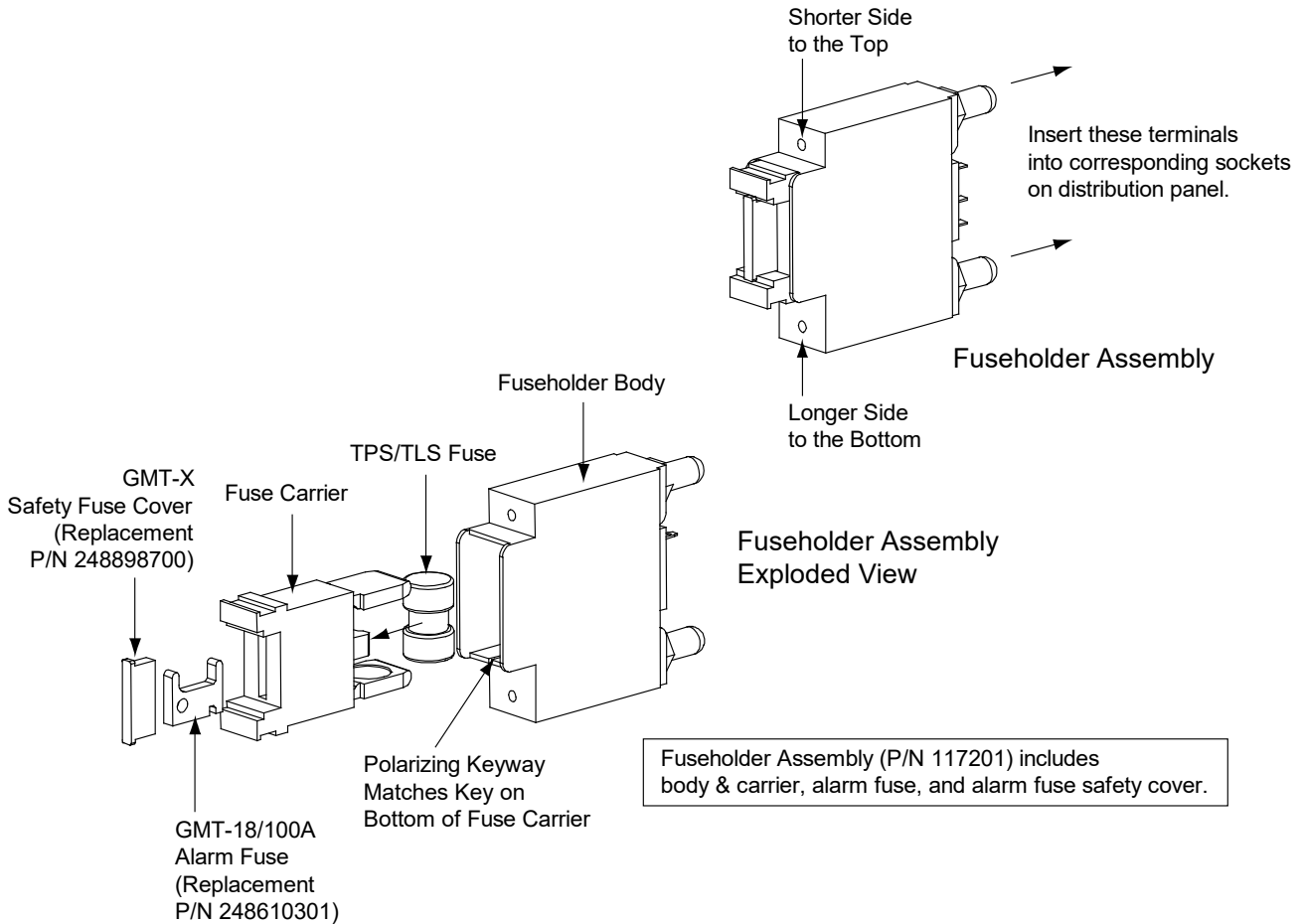

Installing an Optional Bullet Nose Type 6-Position GMT Distribution Fuse Block (P/N 549017)

Procedure

1. Open the distribution cabinet's front door.
2. Follow the steps in Figure 3.8.
3. Install an appropriately sized GMT fuse in each fuse mounting position on the GMT Distribution Fuse Block as required. If dummy fuses are installed, first remove the dummy fuse.
 - a) Verify that dummy fuses are installed in all unused fuse positions on the GMT distribution fuse block.
 - b) Verify that a plastic safety cover is installed on all GMT fuses on the GMT distribution fuse block.
4. Record all fuse sizes (installed on the GMT distribution fuse block) on the label provided on the shield.
5. Close and secure the distribution cabinet's front door.

Figure 3.8: Installing an Optional Bullet Nose Type 6-Position GMT Distribution Fuse Block (P/N 549017)

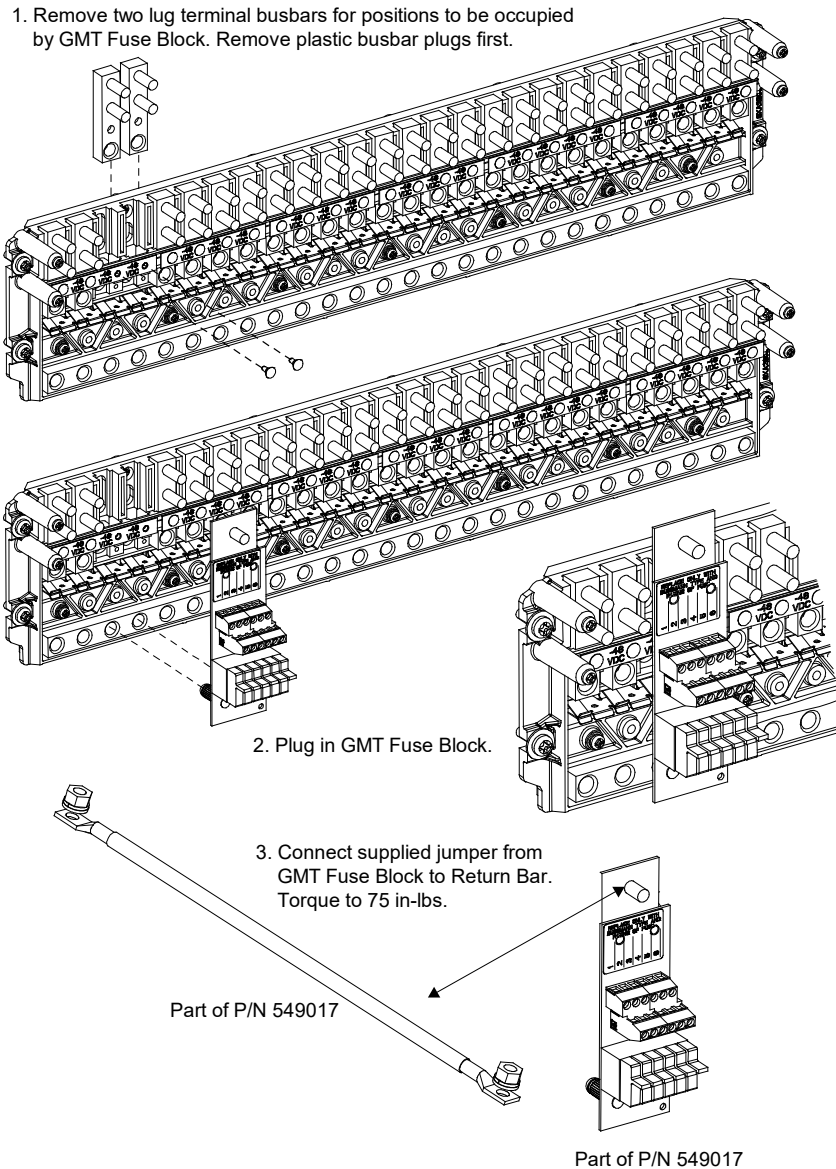

4 Setting Jumper and Switch Options

The various circuit cards inside the distribution cabinet contain jumper and/or switch options.

4.1 Location of Circuit Cards with Jumper and Switch Options

Refer to Figure 4.1 (Lists 600, 601, 900, 901).

Figure 4.1: Location of Circuit Cards with Jumper and Switch Options (Lists 600, 601, 900, 901)

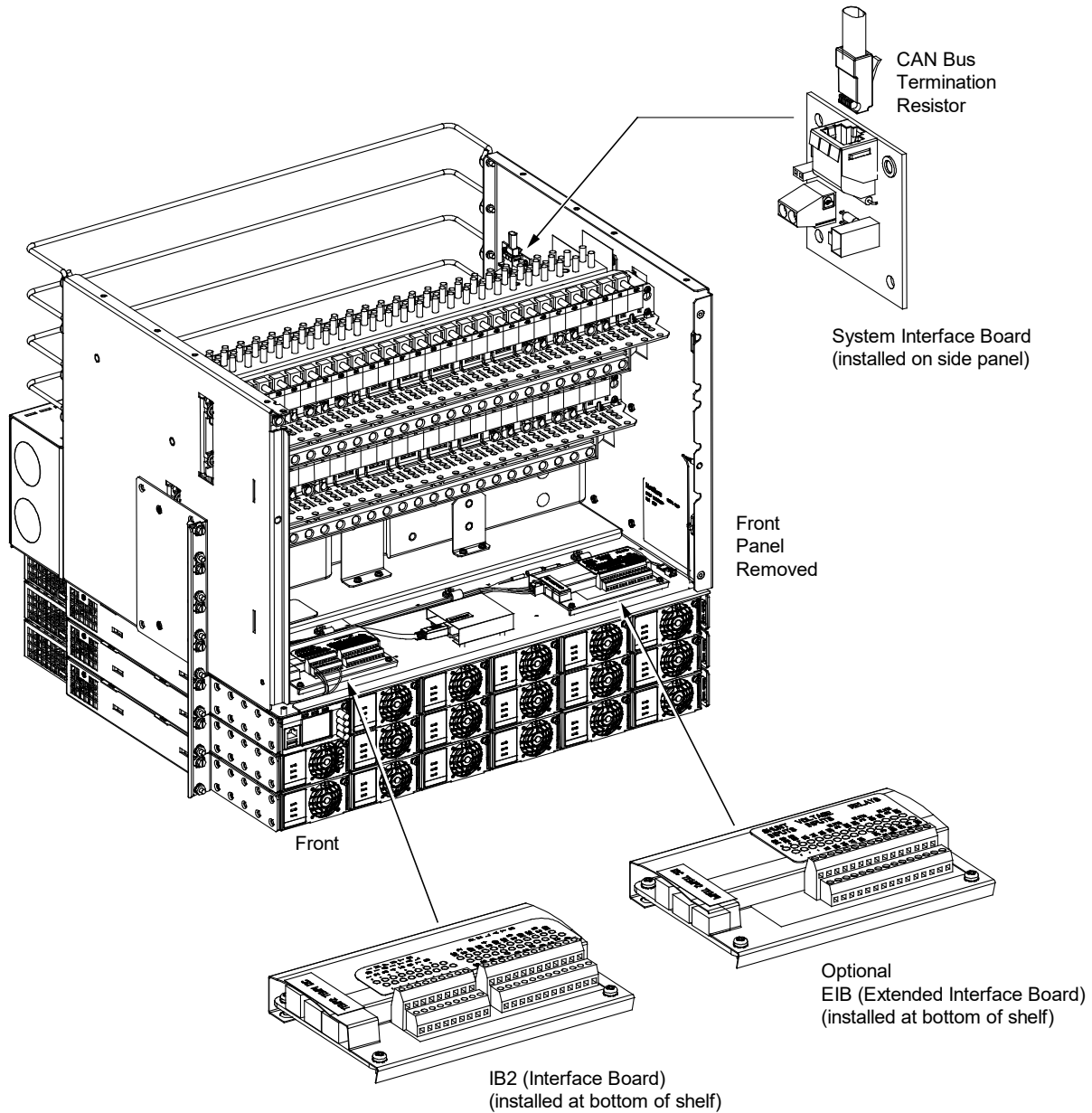

4.2 Jumper Settings on the System Interface Circuit Card

Perform the following procedures to verify the factory settings and/or make the required settings per your site requirements. These procedures can also be used to make adjustments on a replacement circuit card.

Controller Power Option

This option allows the controller to remain powered if a battery LVD contactor is furnished and it opens. The controller is powered from the internal “system” bus. Rectifiers and battery are connected to this “system” bus, so the controller is powered both by the rectifiers and by the battery. A jumper option allows the controller to be powered from the “system side” of a battery LVD contactor (if furnished) or the “battery side” of a battery LVD contactor (if furnished). Refer to Figure 4.2 (Lists 600, 601, 900, 901) for circuit card location and jumper location.

- Jumper in “No Battery Power” Position: The controller is powered from the “system side” of a battery LVD contactor (if furnished). Note if a battery LVD contactor is not furnished, the controller is powered by both rectifiers and battery. If a battery LVD contactor is furnished and opens, the controller is powered by the rectifiers (if functional).

If you lose AC power and your battery LVD contactor opens, the controller will shut down.

- Jumper in “Battery Power” Position: The controller is powered from the “battery side” of a battery LVD contactor (if furnished). Note if a battery LVD contactor is not furnished, the controller is powered by both rectifiers and battery. If a battery LVD contactor is furnished and opens, the controller is powered by the battery and the battery will drain. The controller’s power consumption is 5W.

If you lose AC power and your battery LVD contactor opens, the controller will continue to operate.

Procedure

1. For Lists 600, 601, 900, and 901, refer to Figure 4.2 and place the jumper on J4 in the “Battery Pwr” or “No Battery Pwr” position.

Figure 4.2: System Interface Board Jumper Location and Settings (Lists 600, 601, 900, 901)

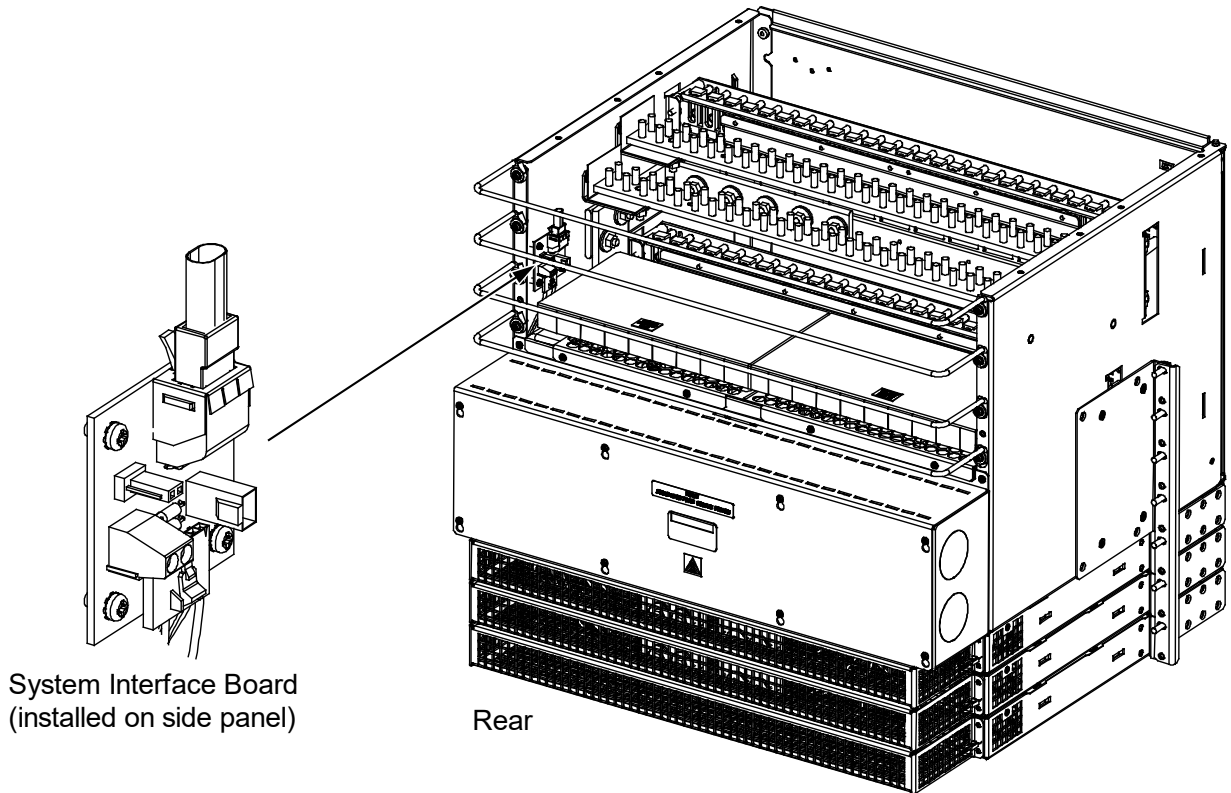

System Interface Board P/N 555484

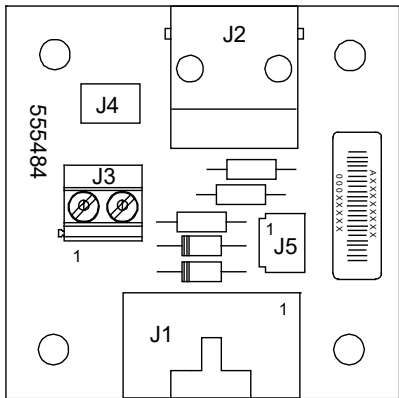

J4 on System Interface Board

Selects to power controller from “Battery Power” or not if a battery LVD contactor is furnished.

No
Battery Battery
Pwr Pwr



Shorting
Jumper

4.3 Switch Settings on the IB2 (Controller Interface Board)

Dip Switch SW1 on the IB2 (Controller Interface Board) is used to set the communications address for this board. Refer to Table 4.1 for SW1 settings. Refer to Figure 4.1 for circuit card location. Refer to Figure 4.3 for SW1 location.

Perform the following procedure to verify the factory settings.

This procedure can also be used to make adjustments on a replacement circuit card.

Procedure

1. Ensure SW1 is set per Table 4.1. Refer to Figure 4.3 for location.

Table 4.1: IB2 Interface Board Switch Settings

Setting	DIP Switch SW1	
	1	2
IB2	OFF	OFF

Figure 4.3: IB2 Interface Board Switch Location and Settings

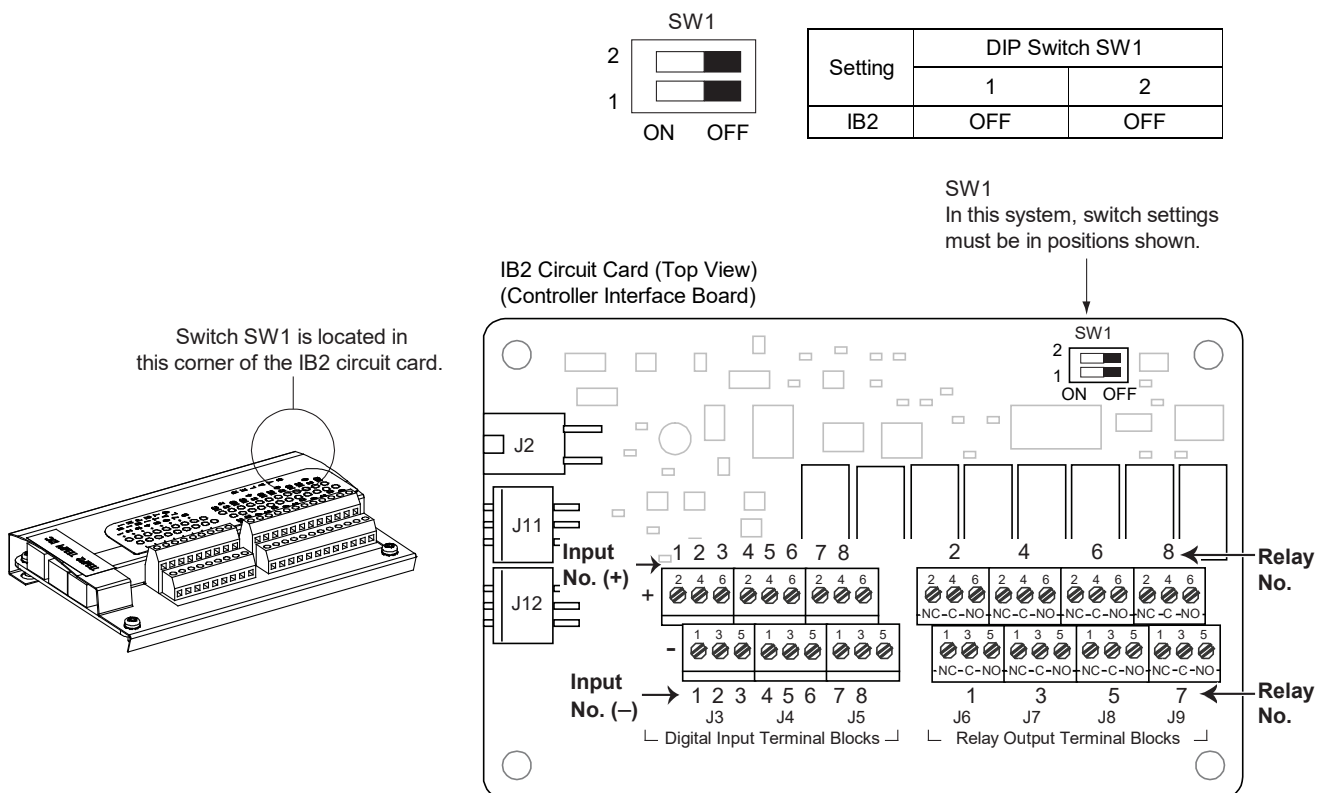

4.4 Switch Settings on Optional EIB (Controller Extended Interface Board)

Dip Switch SW1 on the EIB (Controller Extended Interface Board) is used to set the communications address for this board. Refer to Table 4.2 for SW1 settings. Refer to Figure 4.1 for circuit card location. Refer to Figure 4.4 for SW1 location.

Perform the following procedure to verify the factory settings.

This procedure can also be used to make adjustments on a replacement circuit card.

Procedure

1. Ensure SW1 is set per Table 4.2. Refer to Figure 4.4 for location.

Table 4.2: Optional EIB Extended Interface Board Switch Settings

Setting	DIP Switch SW1	
	1	2
EIB	OFF	OFF

Figure 4.4: Optional EIB Extended Interface Board Switch Location and Settings

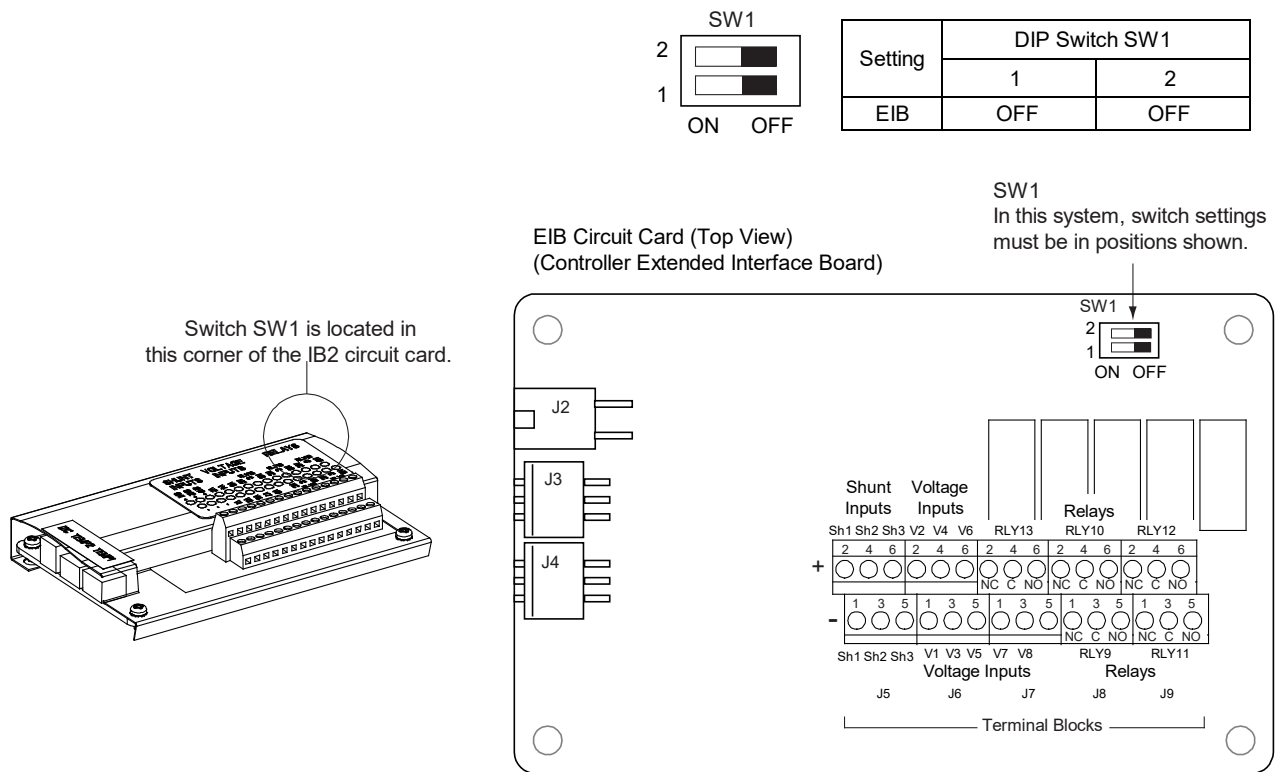

5 Making Electrical Connections

5.1 Important Safety Instructions



DANGER! Adhere to the “Important Safety Instructions” starting on page vi.

5.2 Wiring Considerations

All wiring and branch circuit protection should follow the current edition of the American National Standards Institute (ANSI) approved National Fire Protection Association’s (NFPA) National Electrical Code (NEC), and applicable local codes. For operation in countries where the NEC is not recognized, follow applicable codes.

For wire size, branch circuit protection, crimp lug, and general wiring recommendations; refer to System Application Guide SAG582127000.

Lugs should be crimped per lug manufacturer’s specifications.

Refer to Table 5.1 for supplemental lug crimping information when using the special application crimp lug / strap combination.

Table 5.1: Supplemental Lug Crimping Information when using the Special Application Crimp Lug / Strap Combination

Crimp Lug Part No.		Crimp Tool Required ¹ , T&B Model TBM12 or TBM15 Hydraulic Heads		
		Color Key	Die Index/ Code No.	Die Cat. Number
245393500	Burndy: YA25L-4TCG1	Pink	42H	15508
245393600	Burndy: YA26L-4TCG1	Black	45	15526
245393700	Burndy: YA27L-4TCG1	Orange	50	15530
245393800	Burndy: YA28L-4TCG1	Purple	54H	15511
514872	T & B: 256-30695-1879	Yellow	62	15510
	Burndy: YA29L-4TCG1			
514873	T & B: 256-30695-1880	Red	71	15514
	Burndy: YA31L-4TCG1			

¹ The lugs should be crimped to the specifications given in the manufacturer’s instructions furnished with the crimp tool or lug.

5.3 Relay Rack / Equipment Cabinet Frame Grounding Connection

For relay rack / equipment cabinet frame grounding requirements, refer to the current edition of the American National Standards Institute (ANSI) approved National Fire Protection Association’s (NFPA) National Electrical Code (NEC), applicable local codes, and your specific site requirements.

5.4 Power System Shelf Frame Grounding Connection

For power system shelf frame grounding requirements, refer to the current edition of the American National Standards Institute (ANSI) approved National Fire Protection Association's (NFPA) National Electrical Code (NEC), applicable local codes, and your specific site requirements.

The frame grounding connection to the power system shelf is made by using grounding washers with the mounting hardware used to secure the power system shelf to the equipment rack. Refer to "Mounting the System in an Equipment Rack" on page 3. Ensure that the equipment rack is properly grounded.

Two sets of frame grounding studs are also provided on the rear of the power system shelf. These provide for the installation of a lead with a two-hole lug that has 1/4-inch bolt clearance holes on 5/8-inch centers. Connect a frame grounding lead to one set of studs as required. Refer to Figure 5.1 for location and recommended torque for this connection.

Recommended frame ground wire size is 6 AWG.

Figure 5.1 Power System Shelf Frame Ground Connection

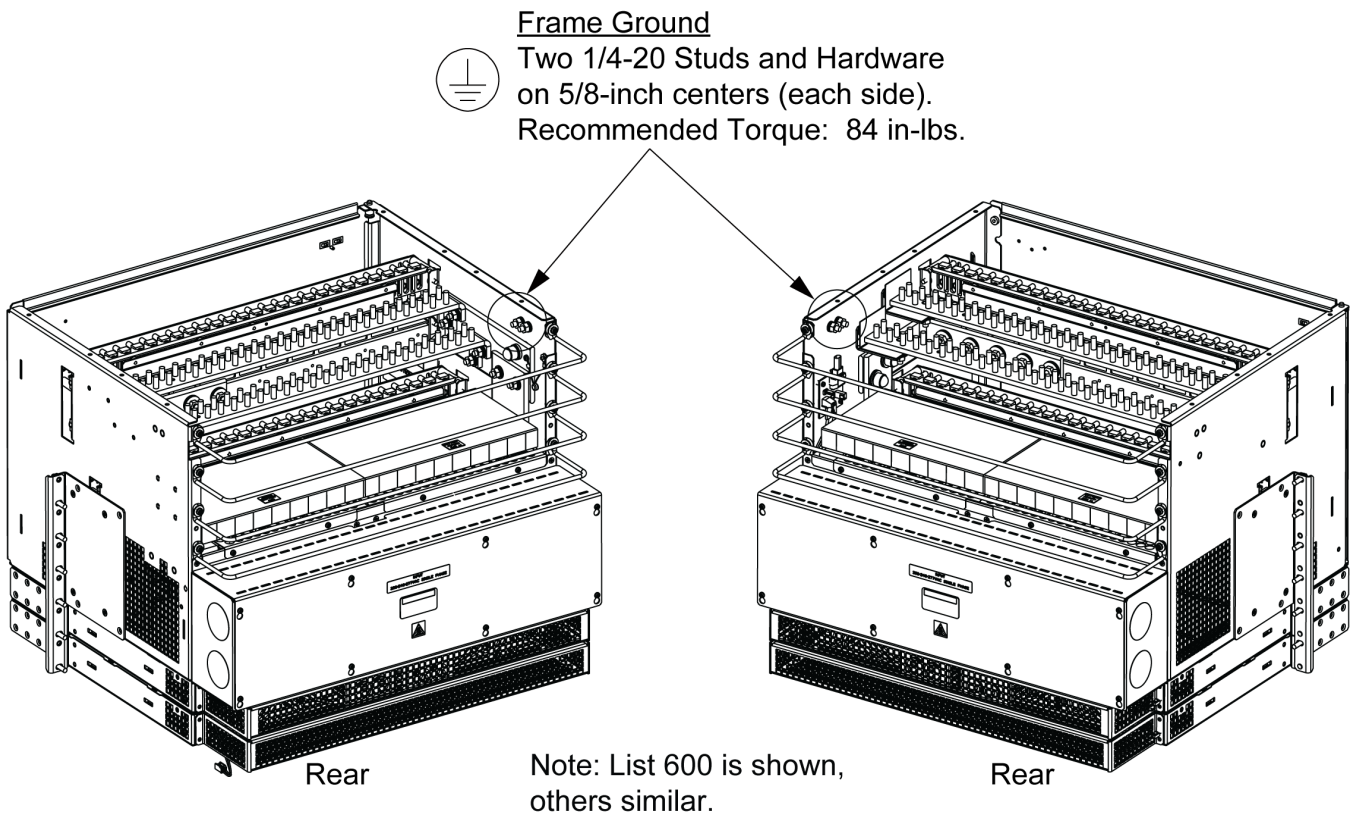

5.5 Central Office Ground Connection

Landing points are provided on the battery return bus for a central office ground lead (see Figure 5.18). For central office grounding requirements, refer to the current edition of the American National Standards Institute (ANSI) approved National Fire Protection Association's (NFPA) National Electrical Code (NEC), applicable local codes, and your specific site requirements.

5.6 AC Input and Equipment Grounding Connections (Nominal 208 VAC, 240 VAC, 277 VAC, Single Phase)

The AC input termination assembly provides two (2) 1-3/4 inch circular openings on each side for AC input and grounding conductors. Plug buttons are factory provided and installed in these openings. Four plastic snap bushings are furnished loose to be installed in the openings to be used to route the AC cables into the AC input termination assembly. It is recommended that AC input wiring be provided to all rectifier mounting positions, including currently unused positions. This wiring will ease future installation of rectifiers to meet increased load requirements.



NOTE! One grounding conductor per conduit must be provided.

Procedure



NOTE! Refer to Figure 5.2 as this procedure is performed.

1. Remove the rear AC input cover by first loosening the screws that secure the cover, then lifting the cover up and out.
2. Install the furnished plastic snap bushings (as required) in the holes located on the sides of the AC input termination assembly. Plug buttons are provided and must be left installed in the openings not being used.
3. There are 2-position bridge jumpers factory-installed on the AC input terminal blocks as shown in Figure 5.2. All jumpers are required for dual feed. Remove all jumpers for single feed.
4. Route wiring into the AC input termination assembly through the previously installed plastic snap bushings.
5. Make AC input connections as shown in Figure 5.2. Connect each wire by inserting the stripped end into the wire opening, and then tightening the screw. Torque connections to value shown in the illustration.
6. Connect equipment grounding leads to the frame ground studs using installer-provided ring lugs and factory-supplied mounting hardware. Torque connections to value shown in the illustration. Refer to Figure 5.2.



NOTE! Equipment grounding conductors must be provided with the AC input conductors supplied to the assembly. Frame ground terminals must be connected to earth ground, not power system neutral. Equipment grounding conductor size based on recommendations of the NEC Table 250-122 for copper wire. If aluminum or copper clad aluminum grounding conductor is used, refer to Table 250 122 for increased conductor size. For operation in countries where the NEC is not recognized, follow applicable codes.

7. After all AC input and equipment grounding connections have been made and checked, reinstall the rear AC input cover and secure by tightening the screws.

Figure 5.2: AC Input Connections to AC Input Termination Assembly (Nominal 208 VAC, 240 VAC, 277 VAC)
(1 Feed per 1 Rectifier, Single Phase or 1 Feed per 2 Rectifiers, Single Phase) (cont'd on next page)

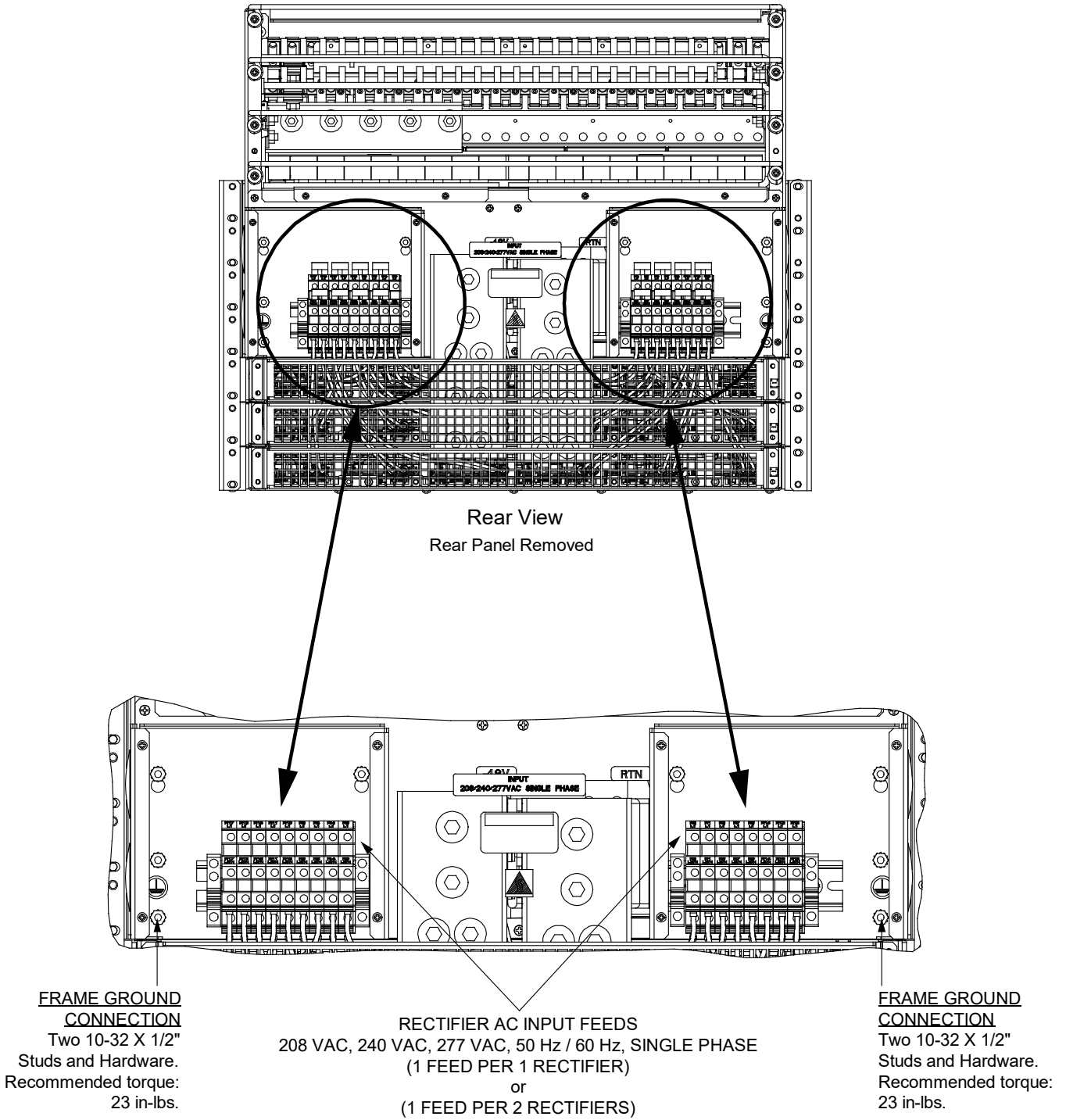

Rear View
Rear Panel Removed

FRAME GROUND CONNECTION

Two 10-32 X 1/2"
Studs and Hardware.
Recommended torque:
23 in-lbs.

RECTIFIER AC INPUT FEEDS
208 VAC, 240 VAC, 277 VAC, 50 Hz / 60 Hz, SINGLE PHASE
(1 FEED PER 1 RECTIFIER)
or
(1 FEED PER 2 RECTIFIERS)

FRAME GROUND CONNECTION

Two 10-32 X 1/2"
Studs and Hardware.
Recommended torque:
23 in-lbs.

Wire Size Capacity: 20 AWG to 6 AWG.
Recommended Torque: 15 in-lbs.

See Next Page

**Figure 5.2: AC Input Connections to AC Input Termination Assembly (Nominal 208 VAC, 240 VAC, 277 VAC)
(1 Feed per 1 Rectifier, Single Phase or 1 Feed per 2 Rectifiers, Single Phase) (cont'd on next page)**

RECTIFIER AC INPUT FEEDS
208 VAC, 240 VAC, 277 VAC, 50 Hz / 60 Hz, SINGLE PHASE
(1 FEED PER 1 RECTIFIER)

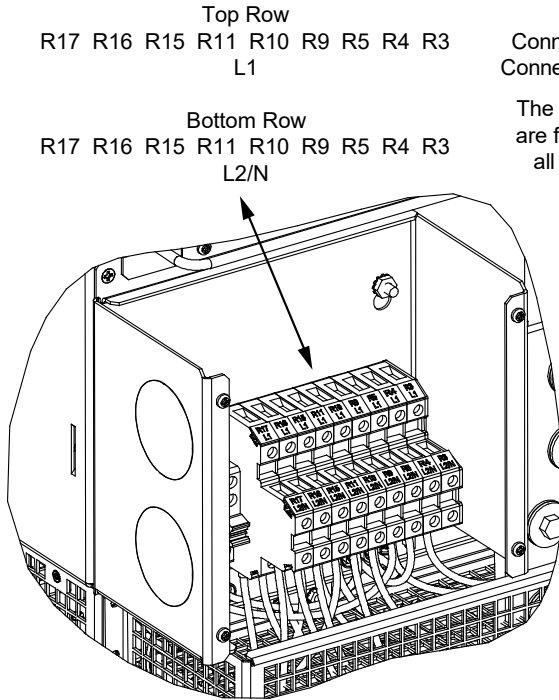

Line to Line:
Connect Line 1 to Terminal L1.
Connect Line 2 to Terminal L2/N.

The 2-position bridge jumpers
are factory-installed. Remove
all jumpers for single feed.

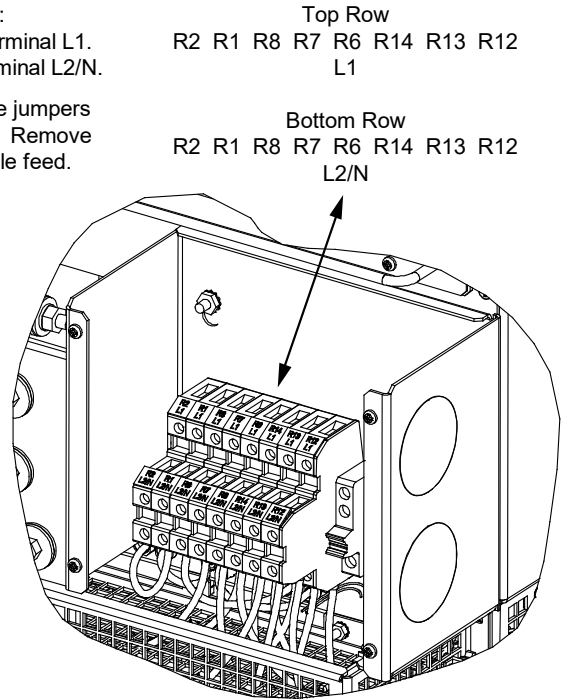

RECTIFIER AC INPUT FEEDS
208 VAC, 240 VAC, 277 VAC, 50 Hz / 60 Hz, SINGLE PHASE
(1 FEED PER 2 RECTIFIERS)

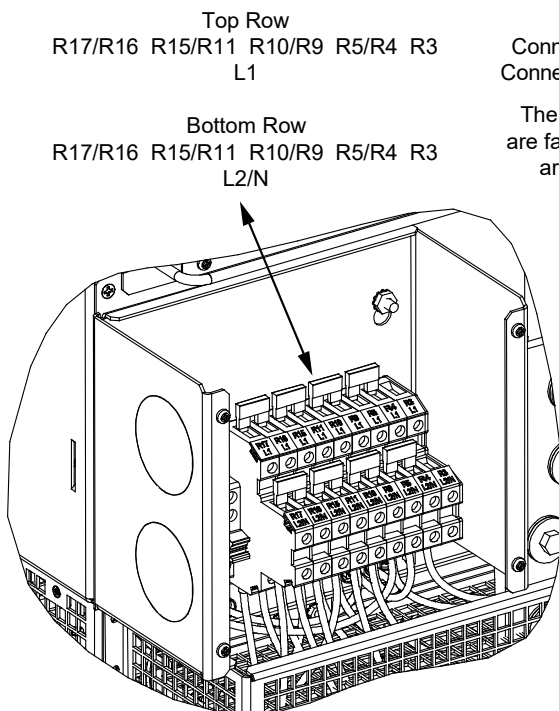

Line to Line:
Connect Line 1 to Terminal L1.
Connect Line 2 to Terminal L2/N.

The 2-position bridge jumpers
are factory-installed. All jumpers
are required for dual feed.

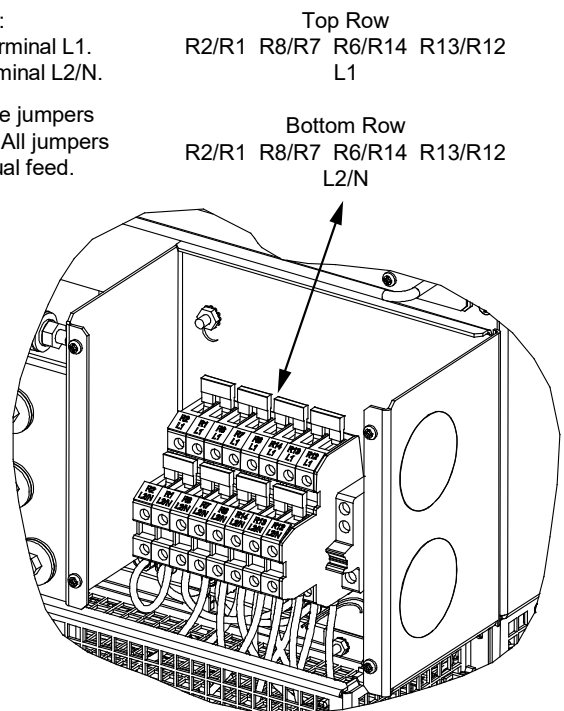

5.7 External Alarm, Reference, Monitoring, and Control Connections

The various circuit cards inside the distribution cabinet contain external alarm, reference, monitoring, and control connectors.

5.7.1 Location of Circuit Cards with External Alarm, Reference, Monitoring, and Control Connectors

Refer to Figure 5.3 (Lists 600, 601, 900, 901) or Figure 5.4 (Lists 930, 931).

Figure 5.3: Location of Circuit Cards with External Alarm, Reference, Monitoring, and Control Connectors – Lists 600, 601, 900, 901

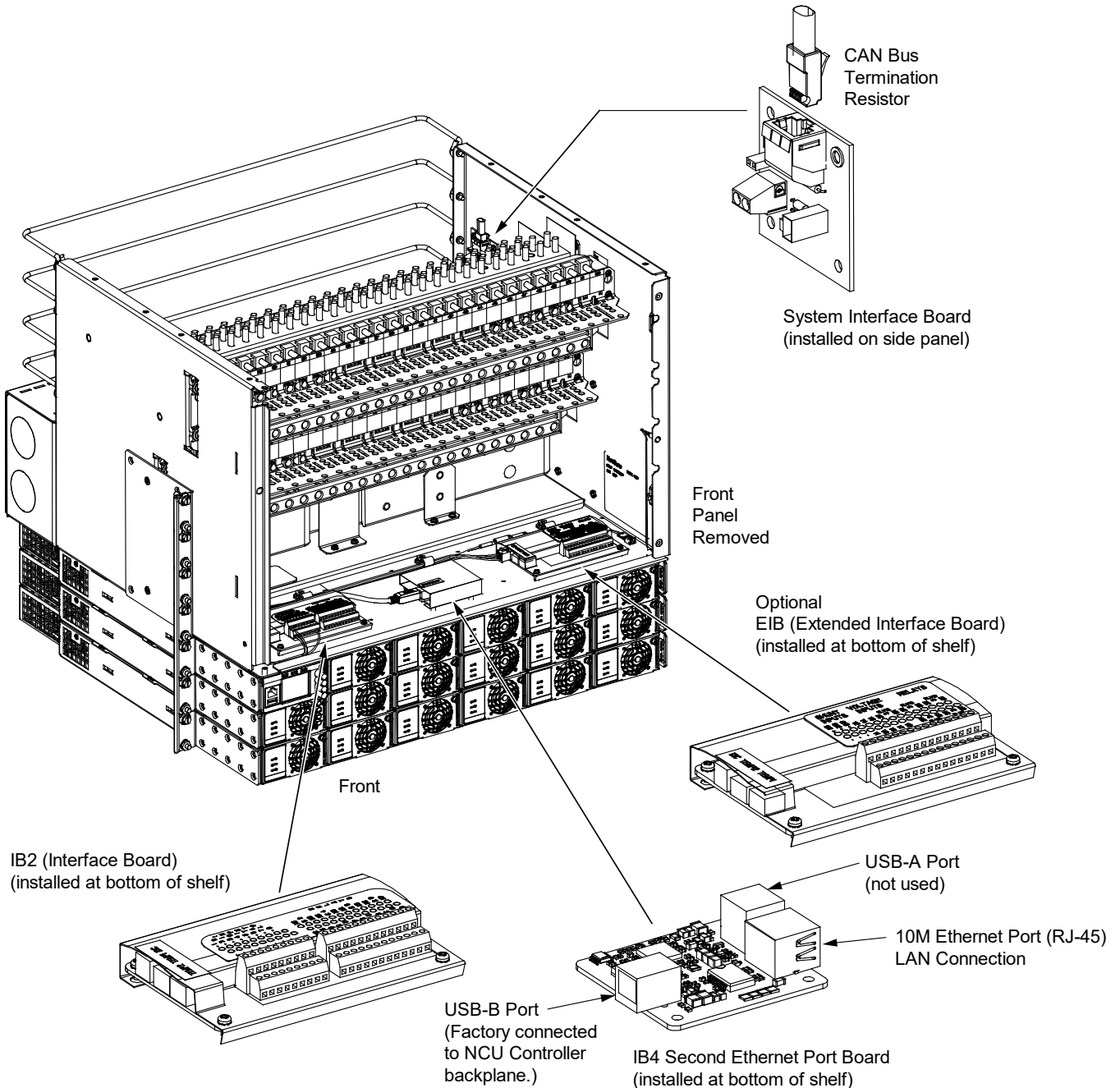
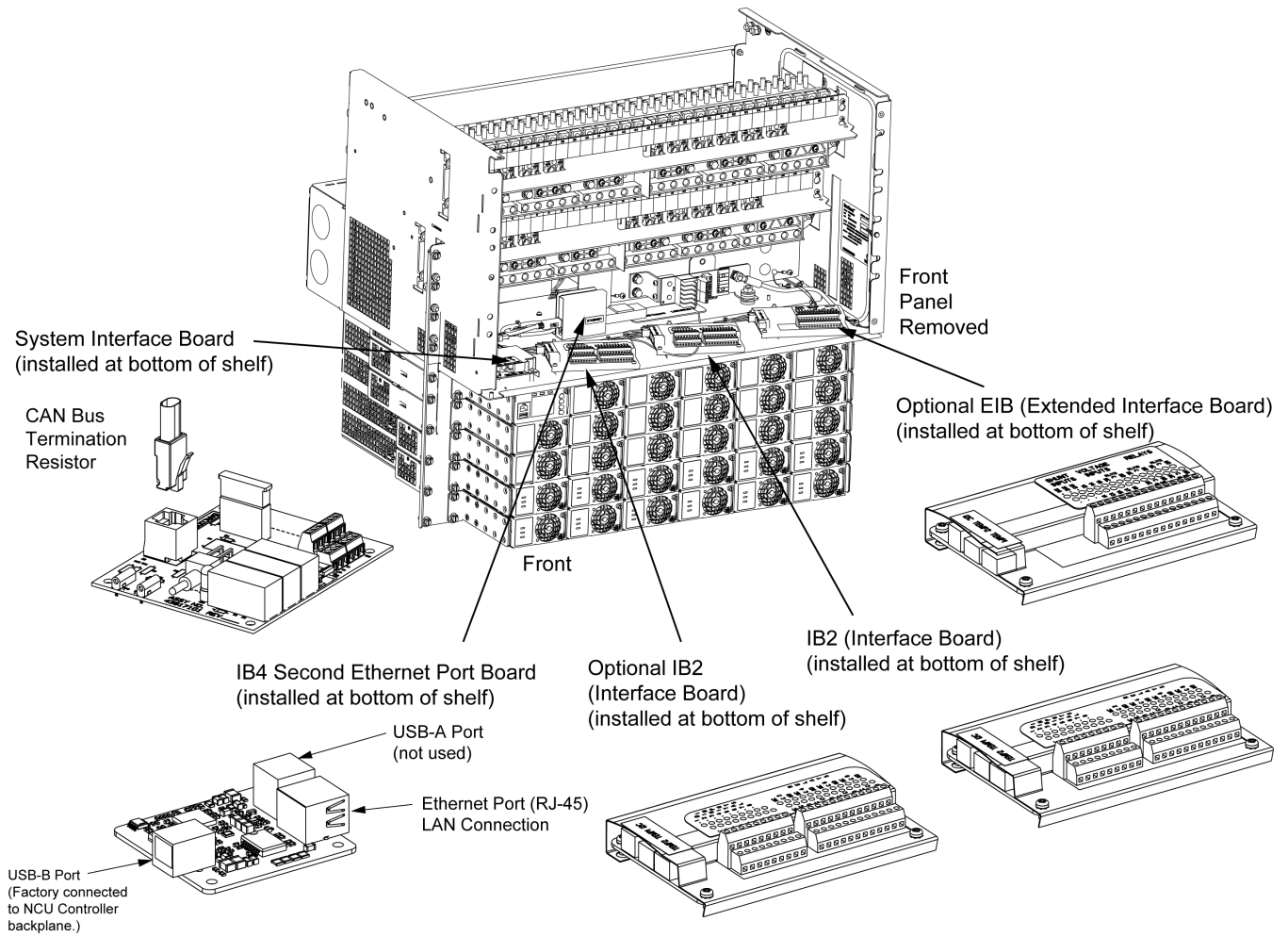

Figure 5.4: Location of Circuit Cards with External Alarm, Reference, Monitoring, and Control Connectors – Lists 930, 931



5.7.2 System Interface Circuit Card Connections (if required)

General

The system interface circuit card provides connections for the following. Refer to Figure 5.5 (Lists 600, 601, 900, 901) or Figure 5.6 (930, 931) for circuit card location and connections details.

- NCU Controller CAN Bus
- RS-485 Modbus (used for communication with SM modules)

Figure 5.5: System Interface Circuit Card Connections – Lists 600, 601, 900, 901

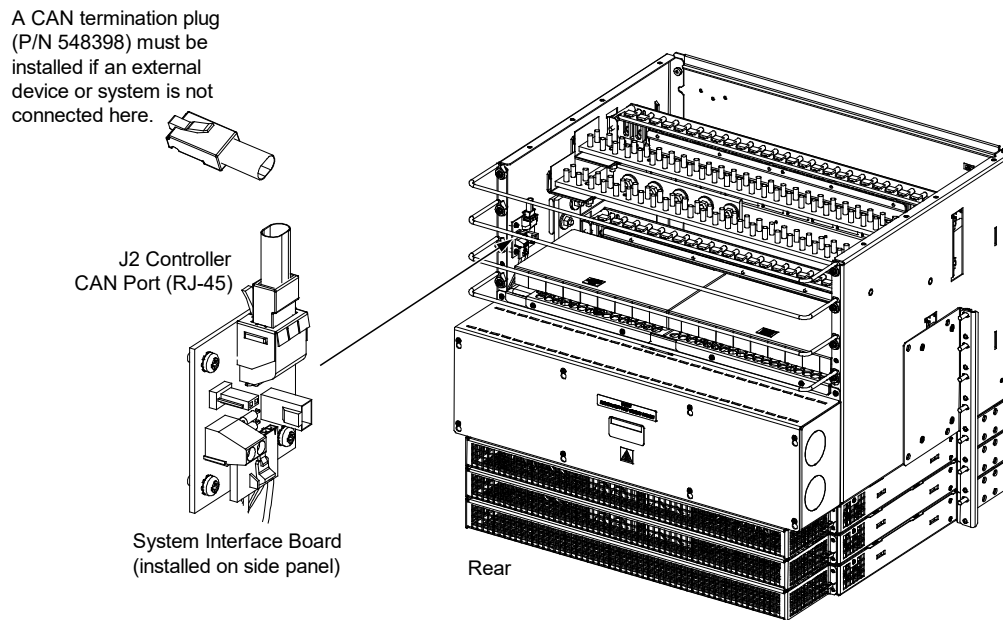

System Interface Board P/N 555484

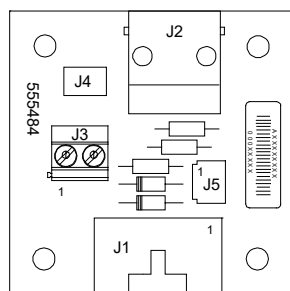

J3 on System Interface Board

Wire Size Capacity: 16 AWG to 30 AWG.

Wire Strip Length: 0.32 inch.

Recommended Torque: 2.3 in-lbs.

RS485 Connection

J3-1: RS485+

J3-2: RS485-

Figure 5.6: System Interface Circuit Card Connections – Lists 930, 931

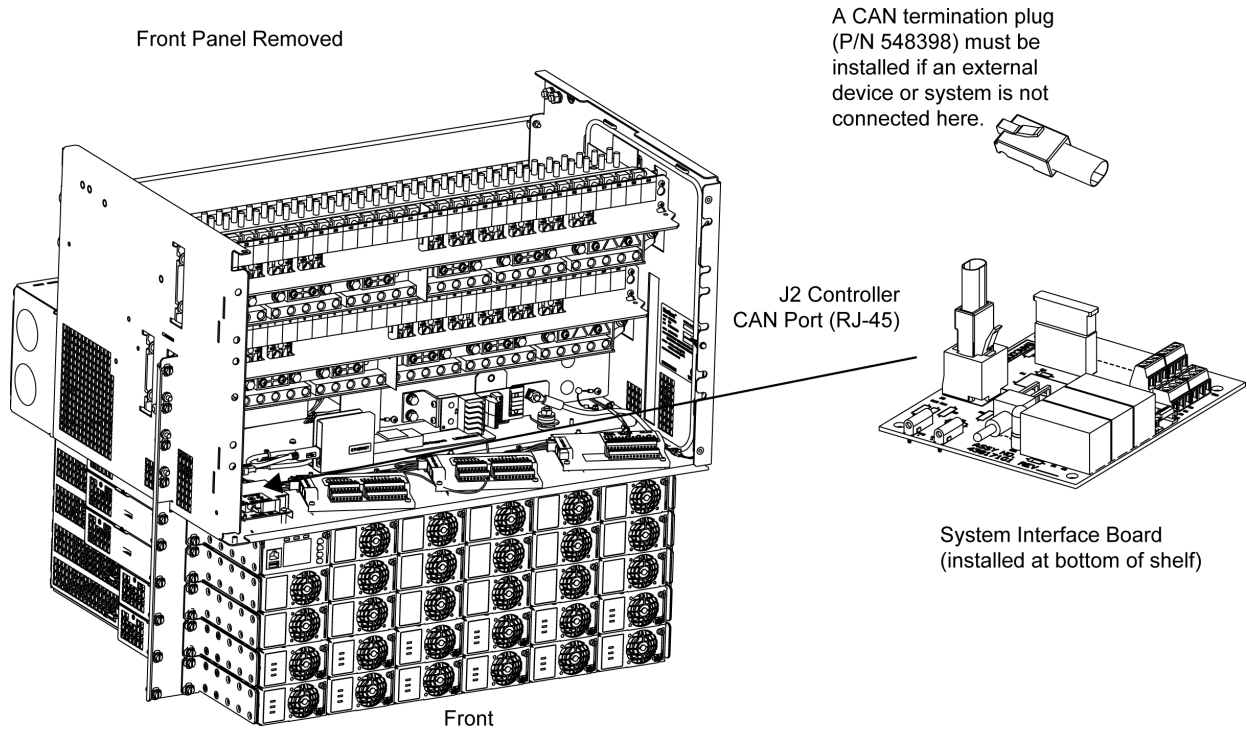

System Interface Board P/N 430171G1

The MAX fuse installed in XF1 can be 5A.

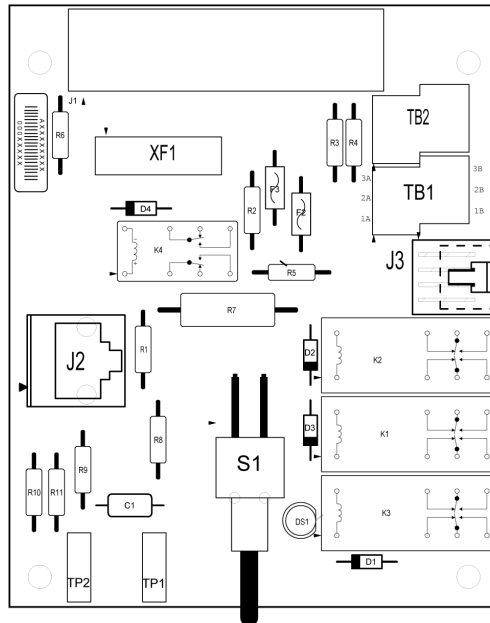
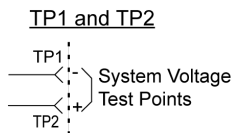

S1: Manual Battery Disconnect (MBD) switch and DS1 illuminates to indicate you're in the MBD mode, which means your Battery LVD is open and your Batteries are disconnected from the system.

- TB1-1A/1B: RS485 Southbound Output
- TB1-2A/2B: RS485 Northbound Output
- TB1-3A/3B: -48V Fused Output that can be used to power external devices
- TB2-1A: External -48V Fuse Alarm Input
- TB2-2A: External -58V Fuse Alarm Input
- TB2-3A: GMT Fuse Alarm Input
- TB2-1B/2B/3B: RS232 Output

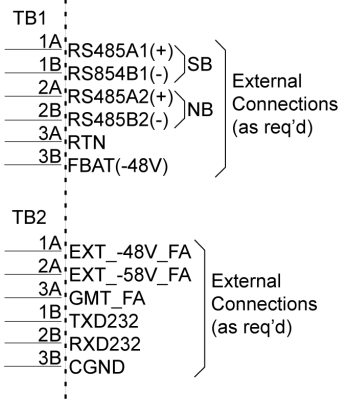

TB2 on System Interface Board
 Wire Size Capacity: 16 AWG to 26 AWG
 Recommended Torque: 2.0 in-lbs.

Connecting a Device or System to the NCU Controller's CAN Bus (if required)

A supporting device or system may be connected to the NCU controller's CAN Port. Refer to Figure 5.5 or Figure 5.6 for location. Refer to Table 5.2 for pin-outs.

General Procedure

1. Remove the CAN termination plug from the CAN port connector located on the system interface circuit card. Connect the device or system to this connector. Refer to Table 5.2 for pin-outs. Ensure that the last device on the NCU controller's CAN bus has a CAN termination plug. Refer also to the external device's or system's instruction manual.
2. Reboot the controller.

Local Menu Navigation: At the Main Screen, press ENT and ESC at the same time to reset the NCU Controller.

Web Menu Navigation: Go to Advance Settings Menu / SW Maintenance Tab / Reboot Controller button.

Optional SM-Temp Module Procedure

The SM-Temp module is connected at the end of the NCU controller's CAN Bus. Refer to the SM-Temp Module Instructions (UM547490) for details.

1. Remove the CAN termination plug from the CAN port connector located on the system interface circuit card. Connect the SM-Temp Module CAN bus to this connector, using separately ordered SM-Temp CAN bus interface cable (P/N 562868). Refer to Table 5.2 for pin-outs. Ensure the last SM-Temp Module (or if only one) has a CAN termination strap as shown in the SM-Temp Module Instructions (UM547490).

Table 5.2: CAN Connections

Controller CAN Port (RJ-45)		SM-Temp Module CAN Port Pin Number
Pin Number	Function	
1	CAN L	TB1-5 (CAN L)
2	CAN H	TB1-3 (CAN H)
3	--	--
4	--	--
5	--	--
6	--	--
7	--	--
8	--	--

RS-485 Modbus Connection (if required) – Lists 930, 931

Refer to Figure 5.5 for location of the RS-485 Modbus connector in the system. Note an RS-485 Modbus interface cable is available (P/N 564643). This cable is 4' long and is terminated at one end with a mating connector and unterminated at the other end. Refer to Table 5.3 for pinouts.

Table 5.3: RS485 Modbus Connector

RS485 Modbus Interface Cable P/N 564643		
Pin	Wire Color	Designation
1	Red	RS485A
2	Black	RS485B
3	Green	CGND

5.7.3 IB2 (Controller Interface Board) Connections (if required)

The IB2 (Controller Interface Board) provides connection points for digital inputs, programmable relay outputs, and temperature probes. The IB2 interface board is mounted inside the distribution cabinet. Refer to Figure 5.3 (Lists 600, 601, 900, 901) or Figure 5.4 (Lists 930, 931).

Programmable Digital Inputs and Relay Outputs

Digital input and relay output leads are connected to screw-type terminal blocks located on the IB2. Recommended torque for these connections is 2.2 in-lbs. Refer to Figure 5.7 for terminal locations. Refer to Table 5.4 and Table 5.5 for pin-out information.

Digital Inputs

Connect up to eight (8) digital inputs to the IB2. Note that you must supply both paths for the digital input (either a positive or negative signal and the opposite polarity return path). Observe proper polarity. Refer to Figure 5.7 for terminal locations and Table 5.4 for pin-out information.

The digital inputs can be programmed to provide an alarm when the signal is applied (HIGH) or removed (LOW). Refer to the NCU Instructions (UM1M830BNA) for programming information.

Digital Input Ratings: Refer to the following.

- a) Maximum Voltage Rating: 60V DC.
- b) Active High: > 19V DC.
- c) Active Low: < 1V DC.

The digital inputs may be preprogrammed for specific functions. Refer to the configuration drawing (C-drawing) supplied with your system for your system's specific configuration.

ESTOP Function



NOTE! -48V is factory wired to the Digital Input #8 (-) terminal for your convenience and function predefined for ESTOP. Customer-furnished system ground applied to terminal Digital Input #8 (+) activates the ESTOP function.

If an ESTOP switch is wired to the IB2, customer-furnished system ground applied to terminal DI8+ activates the ESTOP function. The ESTOP function shuts down and locks out the rectifiers and opens the low voltage battery disconnect contactor (if furnished). If the system has battery connected and does not contain a low voltage battery disconnect contactor or the controller power option is set to Battery Pwr (jumper J4 on the system interface board is set to Battery Pwr), the controller will remain operational. If the system has battery connected and does not contain a low voltage battery disconnect contactor, the loads will be sustained by the battery voltage.

When the ESTOP signal is removed, the low voltage battery disconnect contactor (if furnished) remains open. Rectifiers remain off. The rectifiers restart when input power is removed and restored after 30 seconds or more (until the LEDs on the modules extinguish). When the rectifiers restart, the low voltage battery disconnect contactor closes (if furnished).



NOTE! If a customer-furnished method to disconnect the input power to the system is not provided, the rectifiers will stay locked OFF until the input power is recycled. If the ESTOP signal is removed without recycling the input power, the rectifiers will remain off and have a local alarm visible on the module. The ESTOP alarm from the controller will extinguish. The controller will not issue an alarm for this condition.

Programmable Relay Outputs

The IB2 provides eight (8) programmable alarm relays with dry Form-C contacts. Connect up to eight (8) relay outputs to the IB2. Refer to Figure 5.7 for terminal locations and Table 5.5 for pin-out information.



NOTE! *The relay assigned to “Critical Summary” alarm (relay 1 by default) will operate in the “Fail Safe Mode”. “Fail Safe Mode” means Relay 1 is de-energized during an alarm condition, opening the contacts between the C and NO terminals, and closing the contacts between the C and NC terminals. The remaining seven (7) relays energize during an alarm condition, closing the contacts between the C and NO terminals, and opening the contacts between the C and NC terminals.*

Refer to the NCU Instructions (UM1M830BNA) for programming information.

Relay Ratings: Refer to the following.

- a) Steady State: 0.5 A @ 60V DC; 1.0 A @ 30V DC.
- b) Peak: 3 A @ 30V DC.

The relays may be preprogrammed for specific functions. Refer to the configuration drawing (C-drawing) supplied with your system for your system's specific configuration.

Temperature Probes



NOTE! *Each temperature probe consists of two or three pieces that plug together to make a complete probe. See SAG582127000 for part numbers and descriptions.*

Temperature probes are connected to the IB2 (Controller Interface Board) and/or optional EIB (Controller Extended Interface Board) mounted inside the distribution cabinet. See Figure 5.7 and Figure 5.8.

Up to two (2) temperature probes can be connected to the IB2. Up to two (2) temperature probes can be connected to the EIB. Any combination of the four (4) temperature probes can be programmed to monitor ambient temperature and/or battery temperature. A temperature probe set to monitor battery temperature can also be used for the rectifier battery charge temperature compensation feature, or the battery charge temperature compensation feature can be programmed to use the average or highest value of all battery temperature probes. The battery charge temperature compensation feature allows the controller to automatically increase or decrease the output voltage of the system to maintain battery float current as battery temperature decreases or increases, respectively. Battery life can be extended when an optimum charge voltage to the battery with respect to temperature is maintained. A temperature probe set to monitor battery temperature can also be used for the BTRM (Battery Thermal Runaway Management) feature. The BTRM feature lowers output voltage when a high temperature condition exists to control against battery thermal runaway.

The temperature sensor end of the probe contains a tab with a 5/16" clearance hole for mounting.

A temperature probe programmed to monitor battery temperature should be mounted on the negative post of a battery cell to sense battery temperature. A temperature probe used for battery charge temperature compensation and/or BTRM (Battery Thermal Runaway Management) should also be mounted on the negative post of a battery cell. A temperature probe programmed to monitor ambient temperature should be mounted in a convenient location, away from direct sources of heat or cold.

Figure 5.7: IB2 (Controller Interface Board) Connections

The relay assigned to “Critical Summary” alarm (relay 1 by default) will operate in the “Fail Safe Mode”. “Fail Safe Mode” means Relay 1 is de-energized during an alarm condition, opening the contacts between the C and NO terminals, and closing the contacts between the C and NC terminals. The remaining seven (7) relays energize during an alarm condition, closing the contacts between the C and NO terminals, and opening the contacts between the C and NC terminals.

Not all I/O points may be available for customer connection (some may be used for factory system connections). The digital inputs and relay outputs may be preprogrammed for specific functions. Refer to the configuration drawing (C-drawing) supplied with your system for your system’s specific configuration.

J3-J9:

- Wire Size Capacity: 16 AWG to 26 AWG.
- Wire Strip Length: 0.20 inch.
- Recommended Torque: 2.2 in-lbs.

IB2 Assembly (with shield)

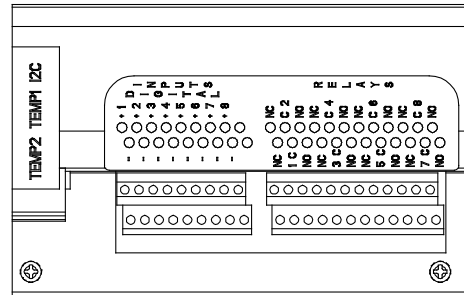

Switch settings must be in this position to interface with the controller.

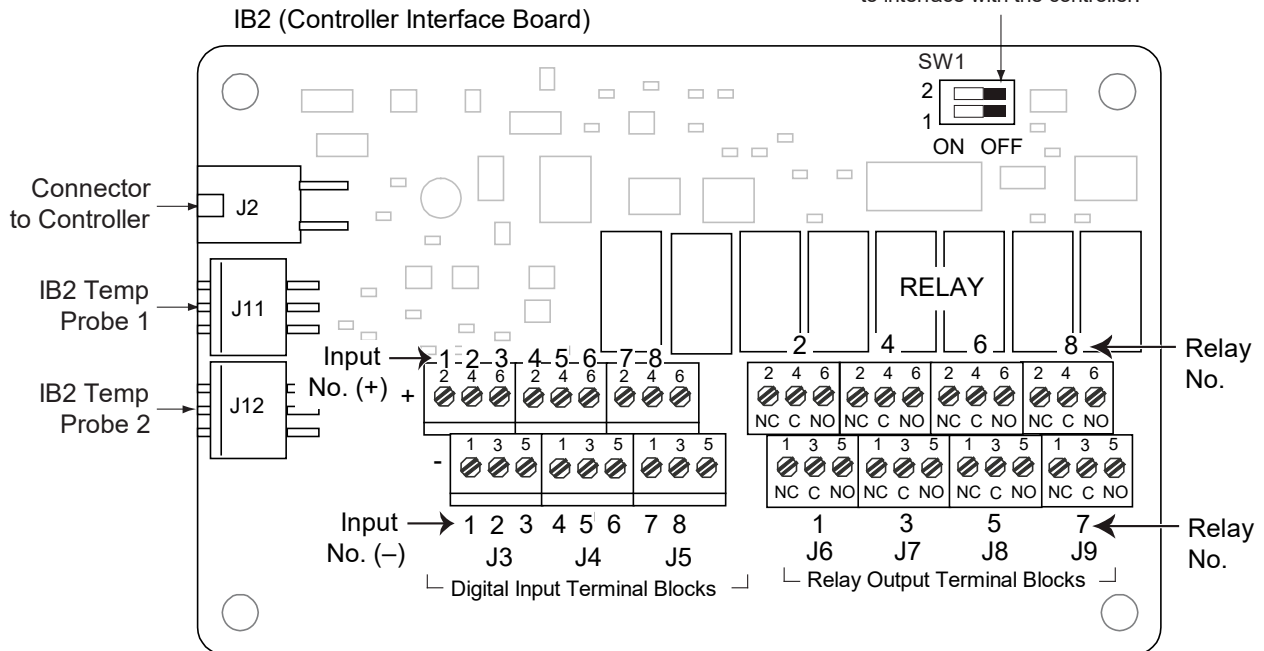

Schematic Diagram of IB2 (Controller Interface Board)

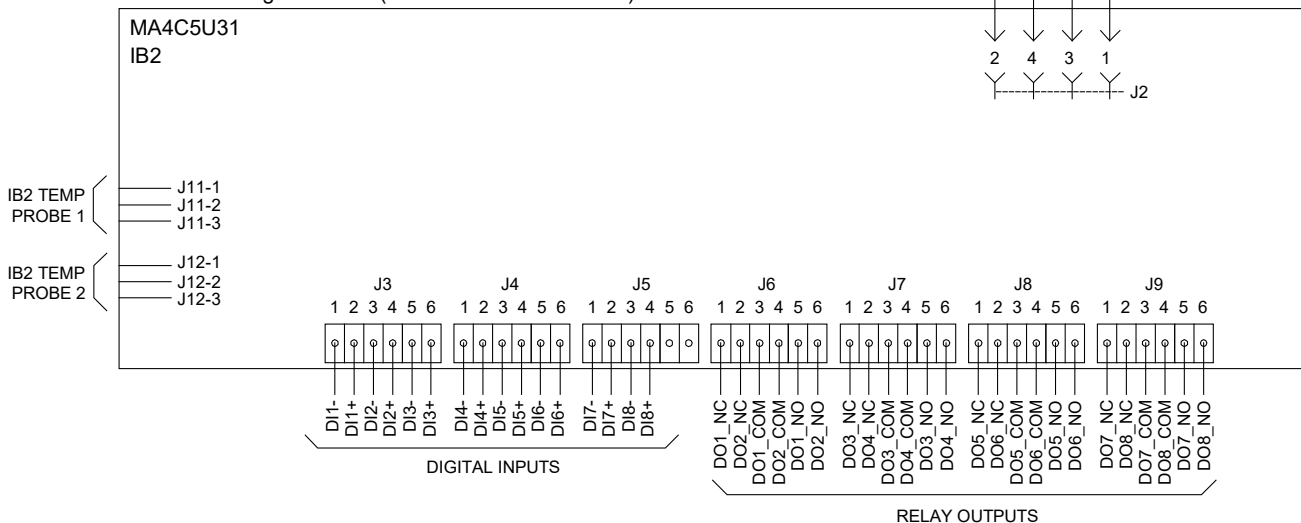

Table 5.4: Programmable Digital Inputs (Factory Default) – IB2

Programmable Digital Input	IB2 Pin No.		Factory Wiring	Default Digital Input Function	Notes
IB2-1 DI1	J3-2	+	System Return	CB/Fuse Alarm	<p>Note: -48V is factory wired to the Digital Input #8 (-) terminal for your convenience and function predefined for ESTOP. Customer-furnished system ground applied to terminal Digital Input #8 (+) activates the ESTOP function. See "ESTOP Function" on page 29.</p> <p>Note: Not all I/O points may be available for customer connection (some may be used for factory system connections). The digital inputs may be preprogrammed for specific functions. Refer to the configuration drawing (C-drawing) supplied with your system for your system's specific configuration.</p>
	J3-1	-	Row1 and Row2 FA		
IB2-1 DI2	J3-4	+	The digital inputs may be preprogrammed for specific functions and have factory wiring connected. Refer to the configuration drawing (C-drawing) supplied with your system for your system's specific configuration.	The digital inputs may be preprogrammed for specific functions. Refer to the configuration drawing (C-drawing) supplied with your system for your system's specific configuration.	
	J3-3	-			
IB2-1 DI3	J3-6	+			
	J3-5	-			
IB2-1 DI4	J4-2	+			
	J4-1	-			
IB2-1 DI5	J4-4	+			
	J4-3	-			
IB2-1 DI6	J4-6	+			
	J4-5	-			
IB2-1 DI7	J5-2	+			
	J5-1	-			
IB2-1 DI8	J5-4	+	(to customer ESTOP switch)	ESTOP	
	J5-3	-	-48 VDC		
--	J5-5		not used	not used	
--	J5-6				

Table 5.5: Programmable Relay Outputs (Factory Default) – IB2 Board

Programmable Relay Output		IB2 Pin No.	Alarms Assigned to this Relay (Default)	Notes
IB2-1 DO1	NO	J6-5	The relays may be preprogrammed for specific functions. Refer to the configuration drawing (C-drawing) supplied with your system for your system's specific configuration.	<p>Note: The relay assigned to "Critical Summary" alarm (relay 1 by default) will operate in the "Fail Safe Mode". "Fail Safe Mode" means Relay 1 is de-energized during an alarm condition, opening the contacts between the C and NO terminals, and closing the contacts between the C and NC terminals. The remaining seven (7) relays energize during an alarm condition, closing the contacts between the C and NO terminals, and opening the contacts between the C and NC terminals.</p> <p>Note: Not all I/O points may be available for customer connection (some may be used for factory system connections). The relay outputs may be preprogrammed for specific functions. Refer to the configuration drawing (C-drawing) supplied with your system for your system's specific configuration.</p>
	COM	J6-3		
	NC	J6-1		
IB2-1 DO2	NO	J6-6		
	COM	J6-4		
	NC	J6-2		
IB2-1 DO3	NO	J7-5		
	COM	J7-3		
	NC	J7-1		
IB2-1 DO4	NO	J7-6		
	COM	J7-4		
	NC	J7-2		
IB2-1 DO5	NO	J8-5		
	COM	J8-3		
	NC	J8-1		
IB2-1 DO6	NO	J8-6		
	COM	J8-4		
	NC	J8-2		
IB2-1 DO7	NO	J9-5		
	COM	J9-3		
	NC	J9-1		
IB2-1 DO8	NO	J9-6		
	COM	J9-4		
	NC	J9-2		

5.7.4 Optional EIB (Controller Extended Interface Board) Connections (if required)

The optional EIB (Controller Extended Interface Board) provides additional connection points for voltage and current inputs, programmable relay outputs, and temperature probes. The EIB extended interface board is mounted inside the distribution cabinet. Refer to Figure 5.3 (Lists 600, 601, 900, 901) or Figure 5.4 (Lists 930, 931).

Current Inputs, Voltage Inputs, and Programmable Relay Outputs

Current input, voltage input, and relay output leads are connected to screw-type terminal blocks located on the EIB. Recommended torque for these connections is 2.2 in-lbs. Refer to Figure 5.8 for terminal locations. Refer to Table 5.6, Table 5.7, and Table 5.8 for pin-out information.

Current Inputs

Connect up to three (3) shunt inputs to the EIB. Observe proper polarity. Refer to Figure 5.8 for terminal locations and Table 5.6 for pin-out information.

Refer to the NCU Instructions (UM1M830BNA) and program the shunt input parameters found in the EIB menu.



NOTE! *The shunt needs to be installed in the hot (-48V) bus. Connect the plus side of the shunt to the positive shunt input on the EIB. Connect the negative side of the shunt to the negative shunt input on the EIB.*

Voltage Inputs for Battery Block and Battery Midpoint Monitoring

The NCU can monitor battery blocks (12V blocks) or midpoint battery voltage of battery strings connected to the EIB. The EIB provides a total of eight (8) DC voltage inputs for these connections. An alarm is issued when either battery block voltage or battery midpoint voltage is abnormal. Refer to Figure 5.8 for terminal locations and Table 5.7 for pin-out information.

Refer to Figure 5.9 for connection details. Refer to the NCU Instructions (UM1M830BNA) and program the following parameters found in the EIB menu.



NOTE! *When using Battery Block Monitoring, you must make connections to all blocks.*

- **Battery Block Monitoring**

Voltage Type: Set to “48 (Block 4)”. This selects the EIB to monitor up to two (2) 48V battery strings with four (4) 12V blocks per string.

BlockVDiff (12V): This menu item appears if “48 (Block 4)” is selected above. Set to the alarm threshold for battery block monitoring per site requirements. The NCU issues an alarm when any block voltage of any battery string has an abnormal value. The alarm is issued when the difference between any block voltage and a reference voltage is greater than the value of the block voltage difference setting.

Block In-Use: Set to the number of 12V battery blocks being used.

- **Midpoint Monitoring**

Voltage Type: Set to “Midpoint”. This selects the EIB to monitor the midpoint voltage of up to eight (8) battery strings.

BlockVDiff (Mid): This menu item appears if “Midpoint” is selected above. Set to the alarm threshold for battery midpoint monitoring per site requirements. The NCU issues an alarm when any battery midpoint voltage of any battery string has an abnormal value. The alarm is issued when the difference between any battery midpoint voltage and a reference voltage is greater than the value of the block voltage difference setting.

Block In-Use: Set to number of 12V battery blocks being used.

Programmable Relay Outputs

The EIB provides five (5) programmable alarm relays with dry Form-C contacts. Connect up to five (5) relay outputs to the EIB. Refer to Figure 5.8 for terminal locations and Table 5.8 for pin-out information.



NOTE! *The five (5) relays energize during an alarm condition, closing the contacts between the C and NO terminals, and opening the contacts between the C and NC terminals.*

Refer to the NCU Instructions (UM1M830BNA) for programming information.

Relay Ratings: Refer to the following.

- a) Steady State: 0.5 A @ 60V DC; 1.0 A @ 30V DC.
- b) Peak: 3 A @ 30V DC.

The relays may be preprogrammed for specific functions. Refer to the configuration drawing (C-drawing) supplied with your system for your system's specific configuration.

Temperature Probes

Temperature probes can be connected to the EIB (NCU Extended Interface Board) mounted inside the distribution cabinet. Refer to "Temperature Probes" on page 30.

Figure 5.9: Sample Battery Block or Battery Midpoint Monitoring Connections

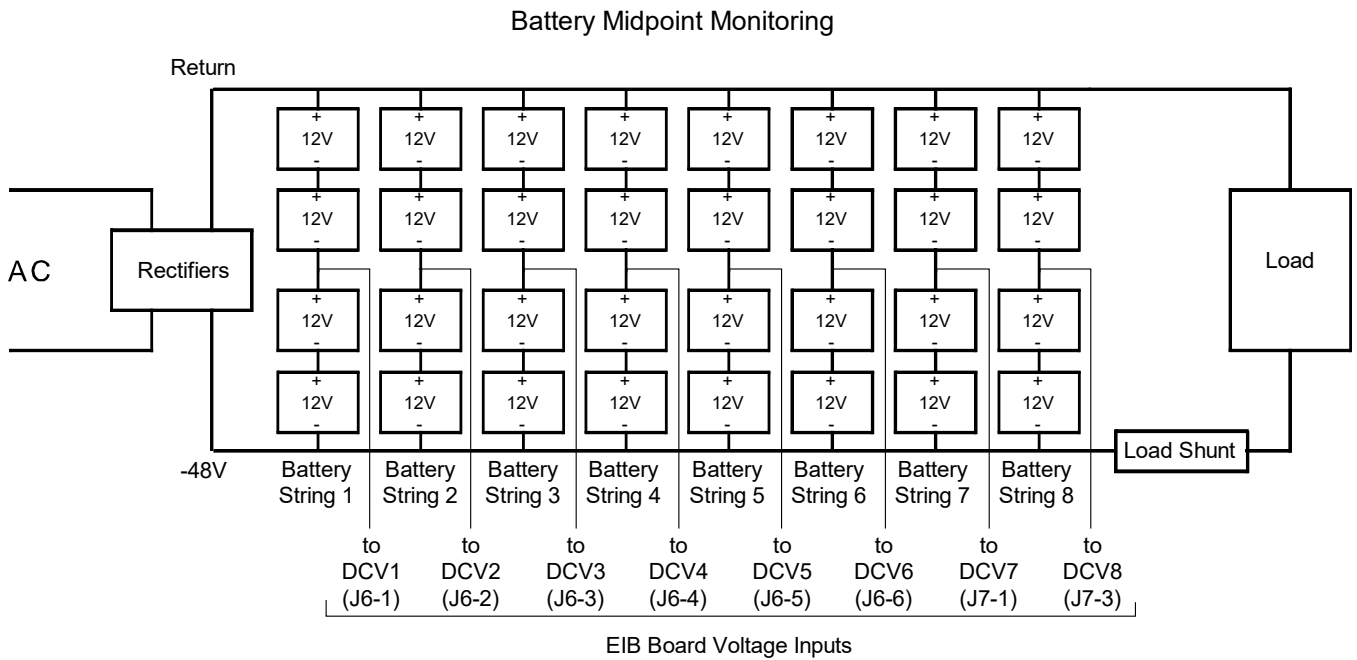
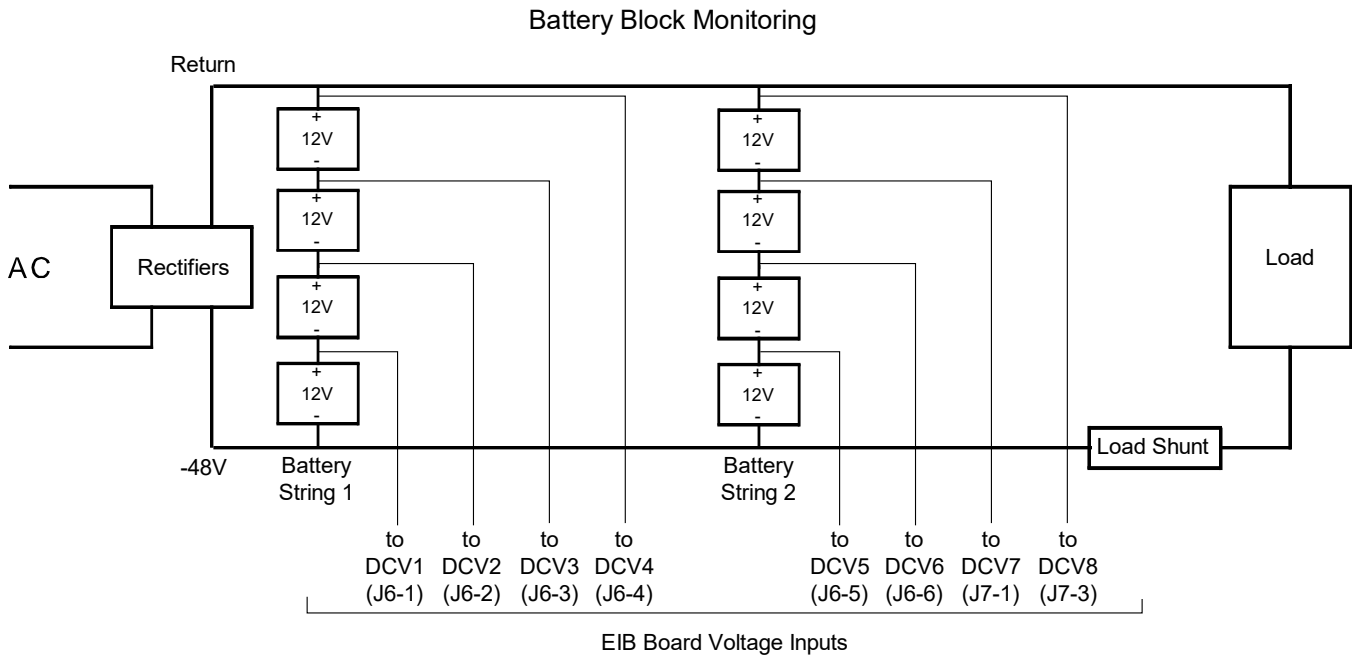

Table 5.6: Shunt Inputs – EIB

Shunt Input	EIB Pin No.		Factory Wiring	Default Function
Sh1	J5-2	+	--	none
	J5-1	-	--	
Sh2	J5-4	+	--	none
	J5-3	-	--	
Sh3	J5-6	+	--	none
	J5-5	-	--	

Table 5.7: Voltage Inputs – EIB

Voltage Input	EIB Pin No.	Default Function
1	J6-1	Battery Block Monitoring
2	J6-2	
3	J6-3	
4	J6-4	
5	J6-5	
6	J6-6	
7	J7-1	
8	J7-3	

Table 5.8: Programmable Relay Outputs – EIB

Programmable Relay Output	EIB Pin No.	Alarms Assigned to this Relay (Default)	Notes
EIB-1 DO1	NO	J8-5	<p>The relays may be preprogrammed for specific functions. Refer to the configuration drawing (C-drawing) supplied with your system for your system's specific configuration.</p> <p>Note: The relays energize during an alarm condition, closing the contacts between the C and NO terminals, and opening the contacts between the C and NC terminals.</p> <p>Note: Not all I/O points may be available for customer connection (some may be used for factory system connections). The relay outputs may be preprogrammed for specific functions. Refer to the configuration drawing (C-drawing) supplied with your system for your system's specific configuration.</p>
	COM	J8-3	
	NC	J8-1	
EIB-1 DO2	NO	J8-6	
	COM	J8-4	
	NC	J8-2	
EIB-1 DO3	NO	J9-5	
	COM	J9-3	
	NC	J9-1	
EIB-1 DO4	NO	J9-6	
	COM	J9-4	
	NC	J9-2	
EIB-1 DO5	NO	J7-6	
	COM	J7-4	
	NC	J7-2	

5.8 NCU Controller Ethernet Connection (if required)

The controller provides a Web Interface via an Ethernet connection to a TCP/IP network. This interface can be accessed locally on a computer and/or remotely through a network. The system has two Ethernet ports. One located on the NCU front panel and the other located on the IB4 board. The function of these Ethernet ports are as follows.

NCU Front Panel Ethernet Port

An RJ-45 10BaseT jack is provided on the front of the controller for connecting a computer directly to the NCU. This jack has a standard Ethernet pin configuration scheme, twisted pair. Refer to Figure 5.10 for location and Table 5.9 for pin outs. Refer to the NCU Instructions (UM1M830BNA) for operational details. Default address: 192.168.100.100.



NOTE! You can access the Web pages of the power system locally by using a "crossover" or "straight" cable connected directly between your PC and the controller.



NOTE! DO NOT connect your Local Area Network (LAN) to the NCU front Ethernet port.

IB4 Board Ethernet Port

An RJ-45 10BaseT jack is provided on the IB4 board for connection into a customer's network. Use this Ethernet port to connect the NCU to your Local Area Network (LAN). This jack has a standard Ethernet pin configuration scheme, twisted pair. Refer to Figure 4.1 (Lists 600, 601, 900, 901) for IB4 board location. Refer to Figure 5.10 for Ethernet port location and Table 5.9 for pin outs. Use shielded Ethernet cable (grounded at both ends). Note that the IB4 board's RJ-45 jack is connected to chassis ground. Refer to the NCU Instructions (UM1M830BNA) for operational details.



WARNING! The intra-building port(s) of the equipment or subassembly is suitable for connection to intra-building or unexposed wiring or cabling only. The intra-building port(s) of the equipment or subassembly **MUST NOT** be metallically connected to the interfaces that connect to the OSP or its wiring. These interfaces are designed for use as intra-building interfaces only (Type 2 or Type 4 ports as described in GR-1089-CORE, Revision 4) and require isolation from the exposed OSP cabling. The addition of Primary Protectors is not sufficient protection in order to connect these interfaces metallically to OSP wiring.

The intra-building port (RJ-45) of the equipment or subassembly must use shielded intra-building cabling/wiring that is grounded at both ends.

Default IB4 Ethernet Port Parameters

IPv4

IP Address: 192.168.1.2
Subnet Mask: 255.255.255.0
Default Gateway: 192.168.1.1

IPv6

IPv6 Address: 20fa:fffd:fffc:fffb:fffa:fff9:fff8:fff7
IPv6 Prefix: 0
IPv6 Gateway: 20fa:1:ffff:ffff:ffff:ffff:ffff:ffff

Figure 5.10: System Ethernet Ports

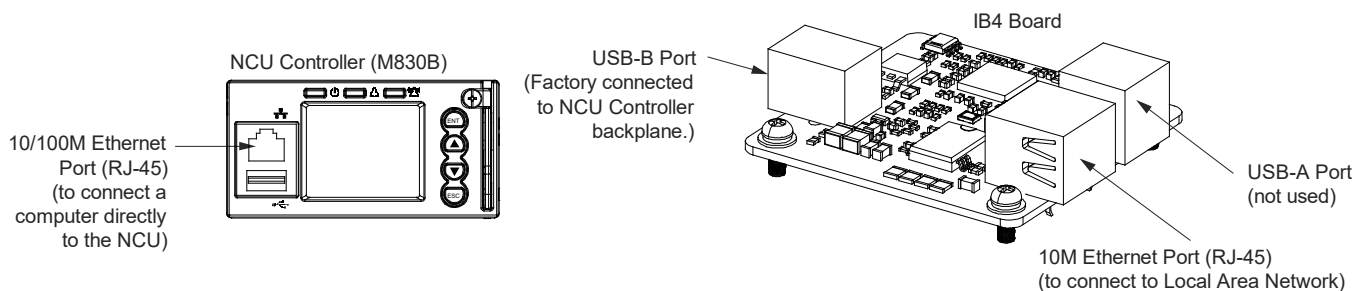

Table 5.9: RJ-45 Ethernet Port Pin Configuration

Port Pin Number	Name	Definition
1	Tx+	Write Signal +
2	Tx-	Write Signal -
3	Rx+	Read Signal +
4	--	no connection
5	--	no connection
6	Rx-	Read Signal -
7	--	no connection
8	--	no connection

5.9 Load Connections

5.9.1 Load Connections to Distribution Panels and Load Return Busbars



WARNING! Observe proper polarity when making load connections.

Load leads are connected to the individual load busbars located on the distribution panels and the load return busbars located at the top of the distribution cabinet. Refer to Figure 5.11 (Lists 600, 601, 900, 901) or Figure 5.12 (Lists 930, 931) for connection details and recommended torque. Customer must provide (or order) lug mounting hardware.

Figure 5.11: Load Connections to Distribution Panels and Load Return Busbars – Lists 600, 601, 900, 901

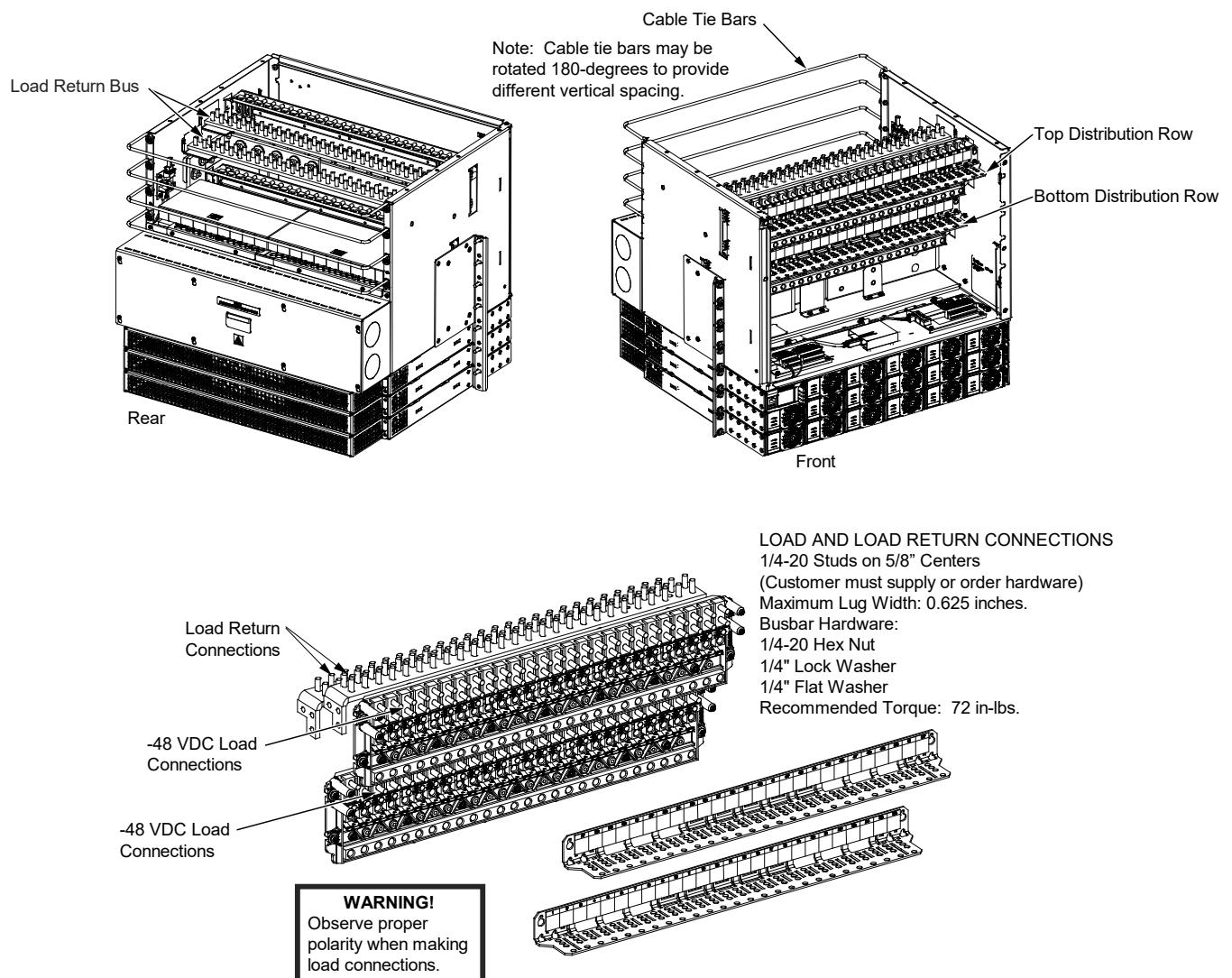

Note: 80 A circuit breakers can be used without a space provided the continuous current in each 80 A device does not exceed 51 A. A 100 A or greater circuit breaker SHALL HAVE an empty mounting position between it and any other overcurrent protective device.

Figure 5.12: Load Connections to Distribution Panels and Load Return Busbars – Lists 930, 931

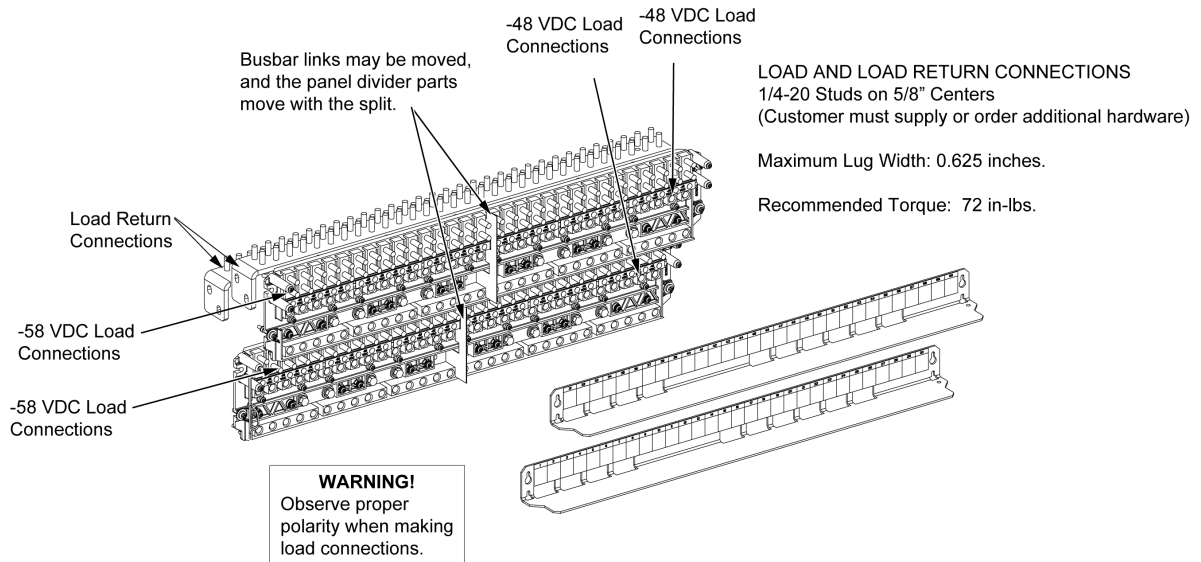
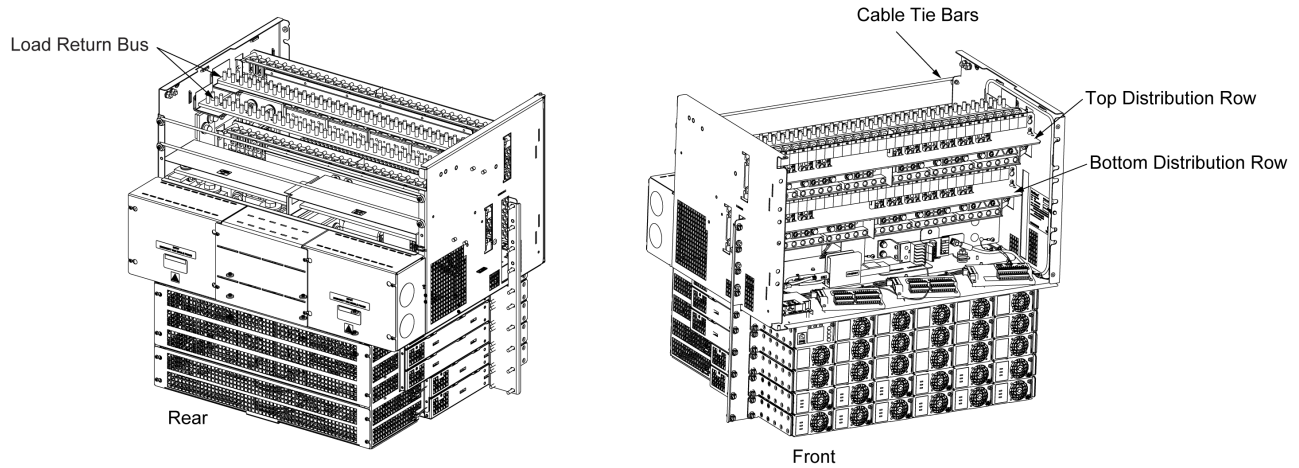

WARNING!
Observe proper polarity when making load connections.

CAUTION: A 100 A circuit breaker or fuse **SHALL HAVE** an empty mounting position between it and any other overcurrent protective device. 100 A circuit breakers can be used without a space provided the continuous current in each 100 A device does not exceed 64 A. A 175 A or greater circuit breaker **SHALL HAVE** an empty mounting position between it and any other overcurrent protective device.

The five right-most positions in each panel are reserved for -48 VDC.
The five left-most positions in each panel are reserved for -58 VDC.
The remaining positions can be selected for either -48 VDC or -58 VDC in groups of five positions.

5.9.2 Reconfiguring Dual Voltage Panel (Lists 930, 931)

Dual voltage panels in List 930 or List 931 can be reconfigured. Refer to Figure 5.13, Figure 5.15, and Figure 5.14 for details.

Procedure

1. Loosen but do not remove screws securing the panel cover to the plastic panel.
2. Remove the divider insulator by gently pulling forward near the top. Refer to Figure 5.13. Folded insulator is press-fit into the plastic panel slot.

Figure 5.13: Divider Insulator, Panel Cover, and Link Busbar

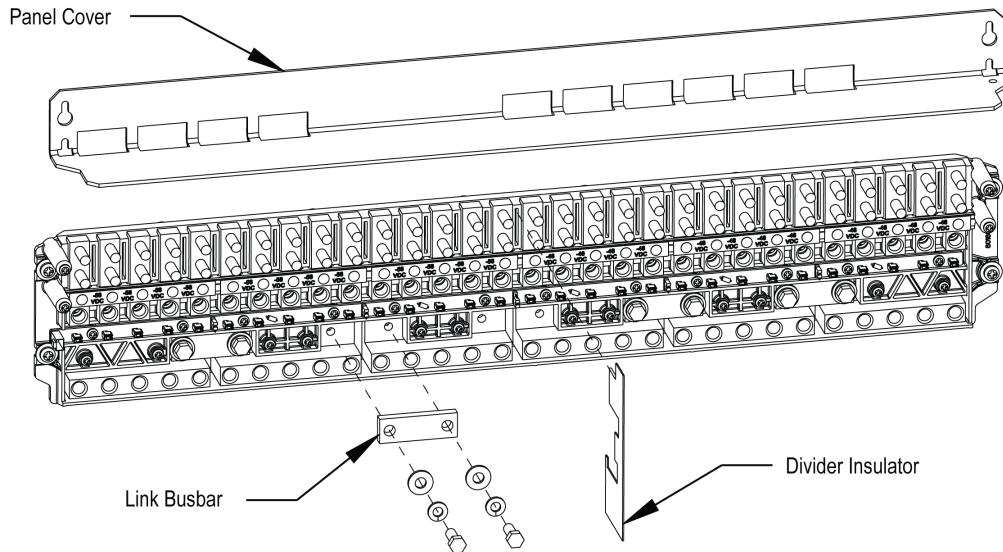

Busbar Link Hardware
 1/4-20 x 5/8" Long Hex Head Cap Screw
 1/4 Lock Washer
 1/4 Flat Washer

3. Move the 3-position alarm jumper at the original split location from ON-position (Up) to OFF-position (Down). Refer to Figure 5.14 for example.

Figure 5.14: 3-Position Alarm Jumpers

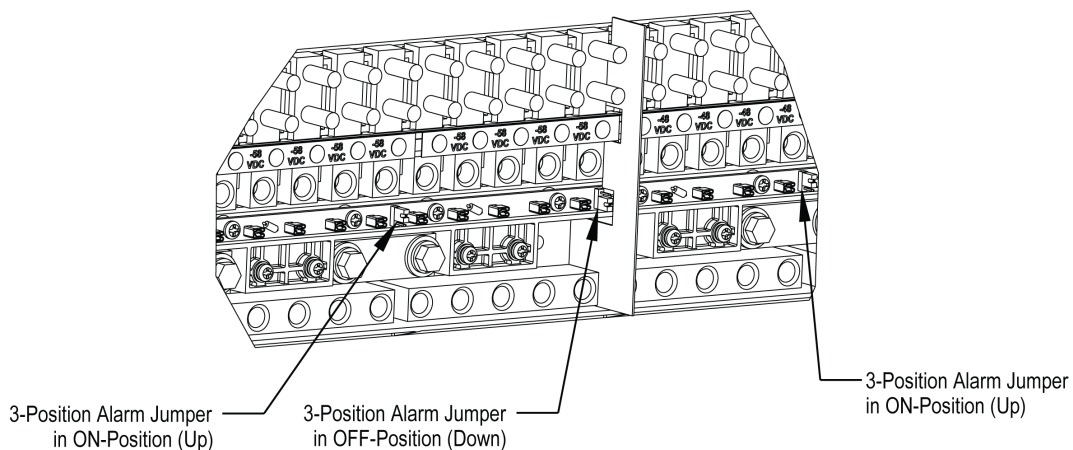

4. Remove link busbar hardware and move to the preferred location. Refer to Figure 5.13. Re-assemble link busbar hardware. Apply torque of 60 in-lbs.
5. Move 3-position alarm jumper at the new split location from OFF-position (Down) to ON-position (Up). Refer to Figure 5.14.
6. Remove pushpins and indicator label(s) as required. Refer to Figure 5.15. Flip indicator label(s) to show opposite side (voltage). Re-install indicator label(s) and pushpins as required.

Figure 5.15: Dual Voltage Panel Reconfiguration

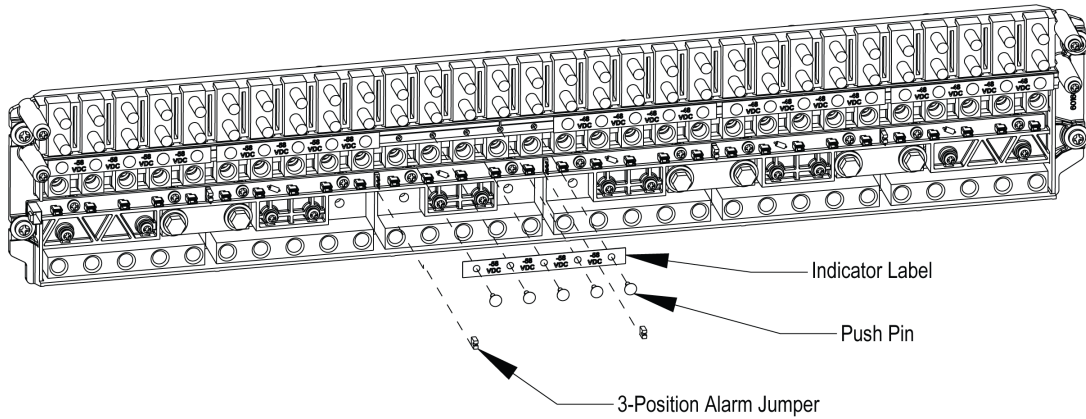

7. Re-install divider insulator at new location.
8. Re-install panel cover and tighten screws.

5.9.3 Load Connections to an Optional Bullet Nose 6-Position GMT Distribution Fuse Block, P/N 549017



WARNING! Observe proper polarity when making load connections.

If an optional “Bullet Nose 6-Position GMT Distribution Fuse Block” is furnished, refer to Figure 5.16 for load connection details and recommended torque.

Figure 5.16: Load Connections to an Optional Bullet Nose 6-Position GMT Distribution Fuse Block, P/N 549017

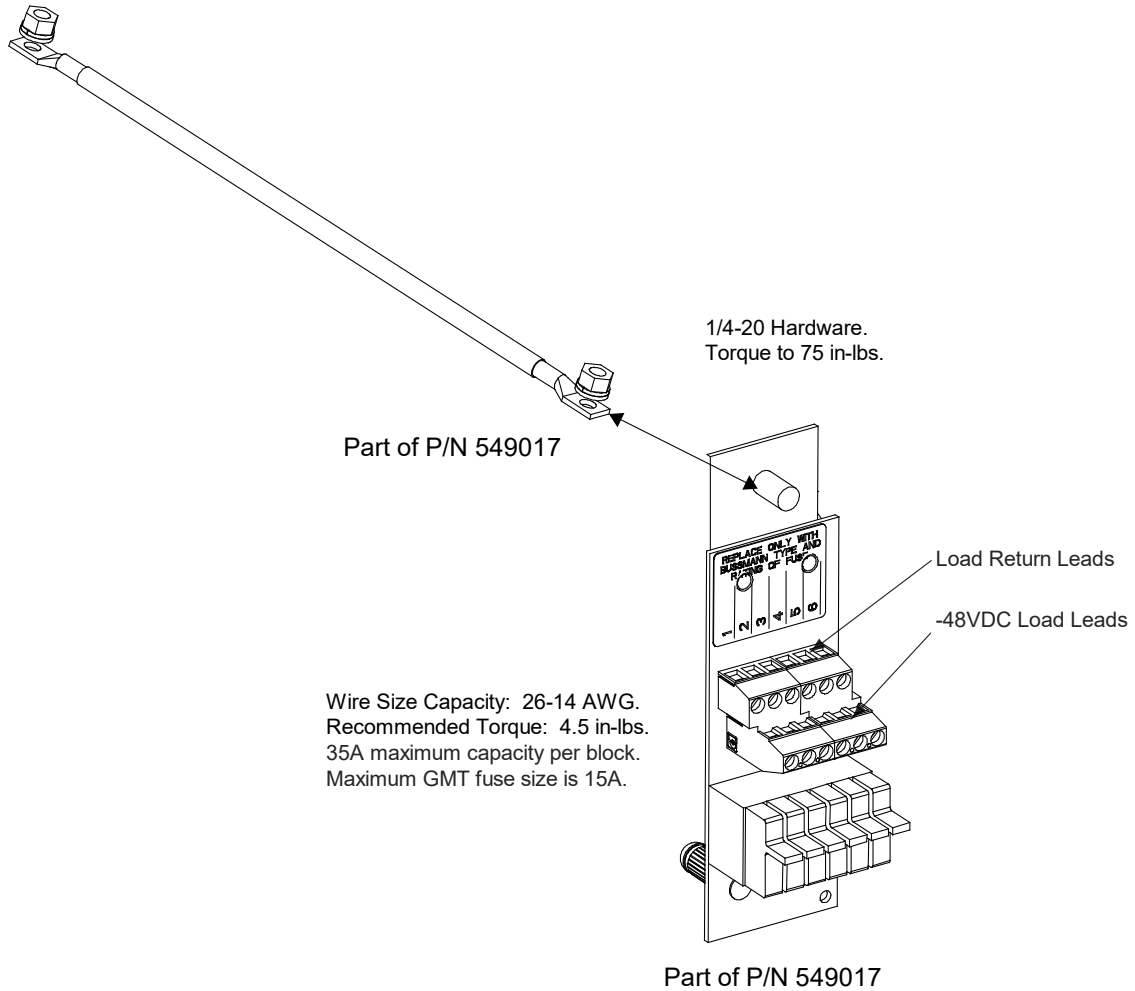

5.9.4 Load Connections to an Optional 6-Position 30A GMT Fuse Kit, P/N 60160806



WARNING! Observe proper polarity when making load connections.

If an optional 6-Position 30A Fuse Kit (P/N 60160806) is furnished, refer to Figure 5.17 for load connection details and recommended torque.

Figure 5.17: Load Connections to an Optional 6-Position 30A GMT Fuse Kit, P/N 60160806

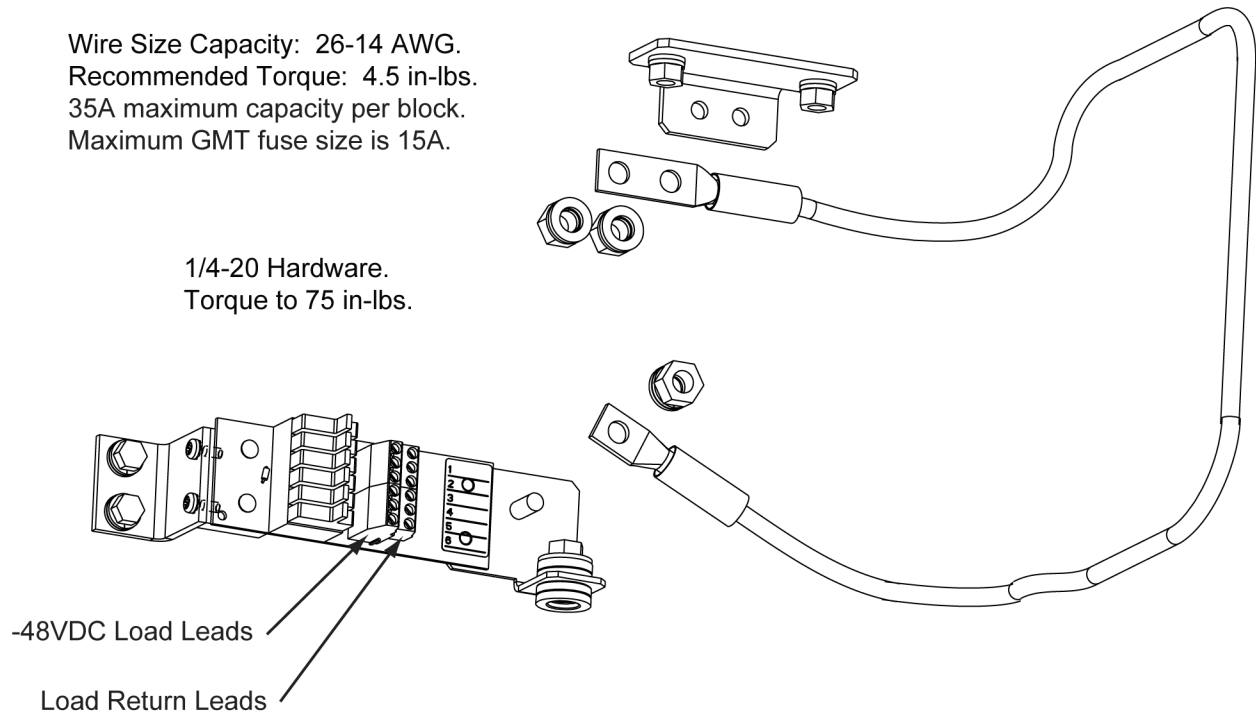

5.10 Battery Connections

WARNING! Observe proper polarity when making battery connections.

Battery leads are connected to the battery (load side) busbar and battery return busbar. Refer to Figure 5.18 (Lists 600, 601, 900, 901) or Figure 5.19 (Lists 930, 931) for connection details and recommended torque. Customer must provide (or order) lug mounting hardware.

Figure 5.18: Battery and Central Office Ground Connections – Lists 600, 601, 900, 901

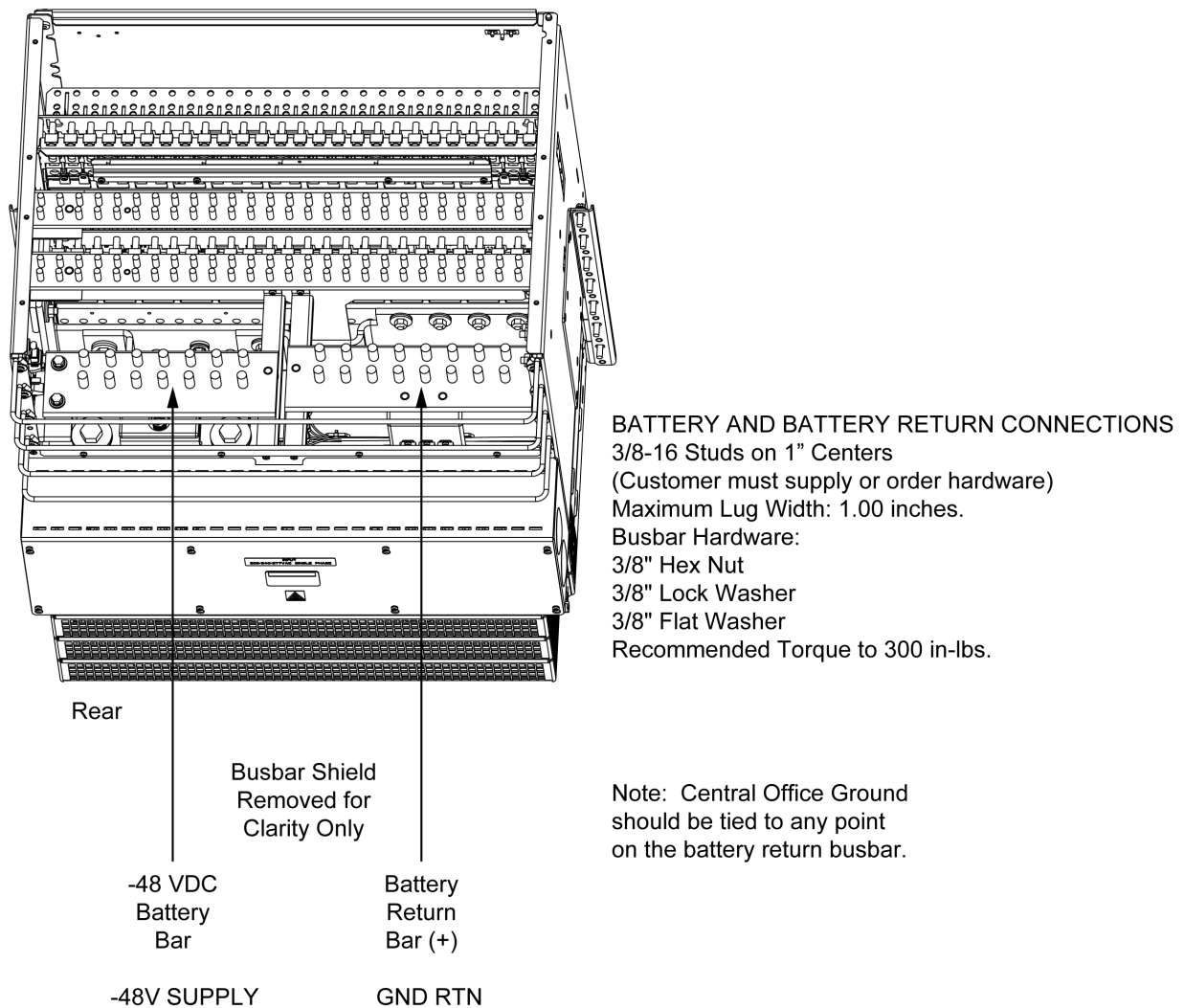
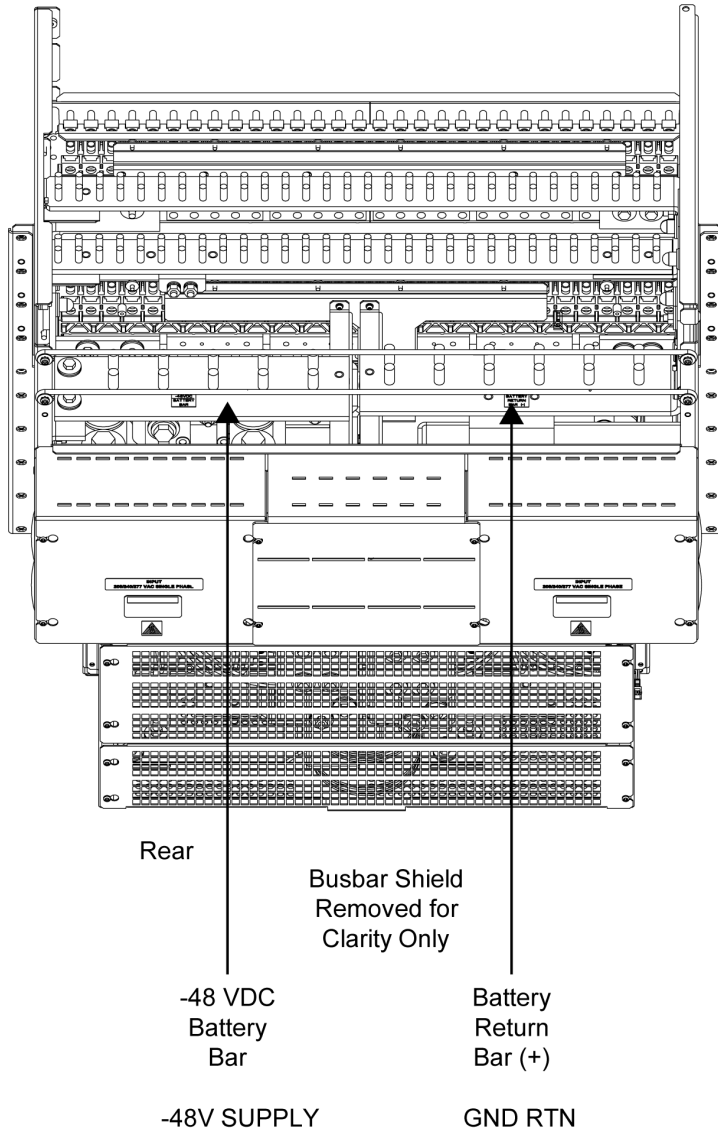

Figure 5.19: Battery and Central Office Ground Connections – Lists 930, 931



BATTERY AND BATTERY RETURN CONNECTIONS

- 3/8-16 Studs on 1" Centers
- (Customer must supply or order hardware)
- Maximum Lug Width: 1.81 inches.
- Busbar Hardware:
- 3/8" Hex Nut
- 3/8" Lock Washer
- 3/8" Flat Washer
- Recommended Torque to 300 in-lbs.

Note: Central Office Ground should be tied to any point on the battery return busbar.

6 Installing Rectifier or Converter Modules

Rectifiers or converters can be inserted or removed with power applied (hot swappable).



NOTE! Each rectifier or converter locks into the module mounting assembly by means of a latch located on the bottom of the module. The latch and rectifier or converter handle are interactive. Pushing the handle up into the module's front panel causes the latch to extend to the locking position; pulling the handle down out from the module's front panel causes the latch to retract. See Figure 6.1.



WARNING! To prevent damage to the latching mechanism, ensure the handle is in the open position when installing or removing a rectifier or converter. NEVER hold the handle in the closed position when installing a rectifier or converter into a shelf.

Procedure

1. Unpack the rectifiers or converters.
2. If present, remove blank cover panels from the module mounting positions into which rectifiers or converters are to be installed.
3. Place the rectifier or converter into an unoccupied mounting position without sliding it in completely.
4. Loosen the captive screw on the module's handle. Pull the handle down out from the module's front panel (this will also retract the latch mechanism). See Figure 6.1.
5. Push the rectifier or converter completely into the shelf.
6. Push the handle up into the module's front panel. This will lock the module securely to the shelf. Tighten the captive screw on the handle.
7. Repeat the above steps for each rectifier or converter being installed in the system.
8. After the modules are physically installed in the mounting assembly(s), they are ready for operation immediately after power is supplied to them.

Figure 6.1: Installing Rectifiers or Converters

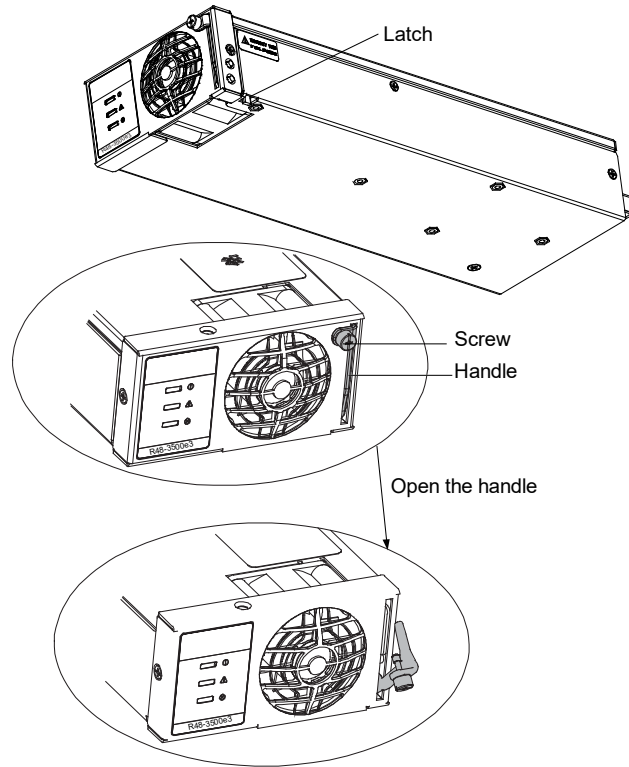

7 Initially Starting, Configuring, and Checking System Operation

7.1 Important Safety Instructions



CAUTION! Performing various steps in the following procedures may cause a service interruption and/or result in the extension of alarms. Notify any appropriate personnel before starting these procedures. Also, notify personnel when these procedures are completed.

7.2 Initial Startup Preparation

- Ensure that all blocks (except the last one) in the “Installation Acceptance Checklist” on 1 have been checked.
- Ensure that rectifier module mounting positions are filled by a rectifier module, as required. It is acceptable for positions to be left vacant. A blank cover panel is available for unpopulated positions. Refer to SAG582127000.
- Refer to the separate NCU Controller User Manual (UM1M830BNA) supplied with your power system for complete controller operating information.
- Refer to the configuration drawing (C-drawing) supplied with your power system documentation for factory settings of adjustable parameters.

7.3 Initially Starting the System



NOTE! After power is initially applied to the system it takes several seconds for the rectifier modules to begin producing power and the control module initialization routine takes several minutes.

Procedure

1. Apply battery power to the system by closing the external battery disconnect(s) or protective device(s) that supplies battery power to the system, if furnished.
2. Apply rectifier AC input power to the system by closing ALL external AC disconnects or protective devices that supply rectifier AC power to the module mounting assemblies. Rectifiers automatically start.
3. Open the distribution cabinet’s front door.
4. Place each distribution circuit breaker (if furnished) to the ON position.

7.4 NCU Controller Initialization

Refer to the separate NCU Controller User Manual (UM1M830BNA) for detailed instructions.

Refer to Figure 7.1 for locations of the NCU local indicators and navigation keys.

Figure 7.1: NCU Local Indicators and Navigation Keys

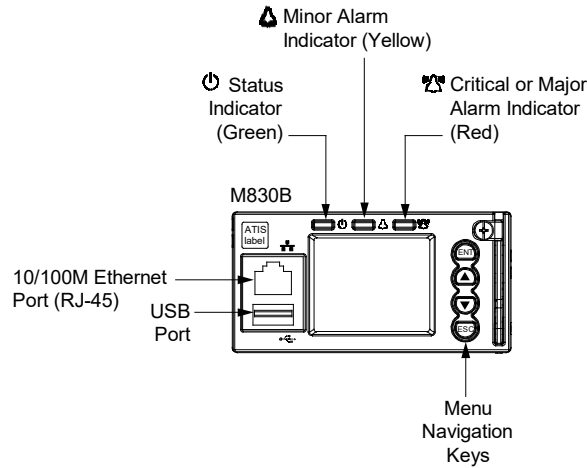

Procedure

NOTE! The initialization routine takes several minutes. During that time, various alarm indicators may illuminate on the NCU front panel and an audible alarm may sound. Disregard all alarms. An audible alarm can be silenced at any time by momentarily depressing the **ENT** key on the NCU Controller.

1. After the NCU is powered on, the display shows the “logo” screen. The controller is initializing.
2. When initialization is complete, the language screen appears. Press the up or down arrow key to select the desired language. Press the **ENT** key to confirm the selection.
3. The Main Menu displays.

Main Menu

Date and time are alternately displayed. Green - No Alarm The number in () indicates the total number of alarms.
 Red - Alarm

Graphics	Menu Name	Description
	Alarm (Green - No Alarm) (Red - Alarm)	View active alarms and alarm history.
	Settings	Gain access to the NCU Controller's settings menus.
	Input Power	View AC, Solar, DG, and Wind related information.
	Module	View rectifier, solar converter, and converter module related information.
	DC	View DC equipments related information.
	Battery	View battery related information.

Press the UP and DOWN keys to highlight the desired Menu graphic in the Main Menu.
 Press the ENT key to enter the selected menu.

To reboot the Controller, from the Main Menu press the ENT and ESC keys at the same time. Release both keys. Press ENT to confirm.

NOTE! “Rect Cap Used” is based on the number of installed rectifiers.

4. System information is displayed in multiple screens. Press the ESC key to view other system information. Press the down arrow key to view the next screen. Press the ESC key to return to the Main Menu.

- From the Main Menu, press the UP and DOWN keys to highlight the desired Menu graphic in the Main Menu. Press the ENT key to enter the selected menu.



NOTE! Repeatedly press the “ESC” key to return in reverse order level by level from any submenu until the Main Menu appears.

- Refer to the following procedures to verify and set the NCU controller as required for your application.

7.5 Verifying and Setting the NCU Controller as Required for Your Application

Refer to the NCU Controller User Manual (UM1M830BNA) for additional information.

Note that you will have to program the NCU for any temperature probes and external inputs/outputs connected to the IB2 Interface Board and optional EIB Extended Interface Board.

Refer also to “NCU Start Wizard” on page 53.



NOTE! When setting total rectifier current limit, the set point to each unit is the total set point divided by the number of units. For example, if the system contains five rectifiers and the current limit is set to 150 amps then each rectifier has a current limit set point of 30 amps. If one or more rectifiers are removed or fail, it will take several seconds for the individual set points to the remaining rectifiers to be reset. In the example given, if one rectifier is removed the current limit set point will drop to 120 amps (30 amps times four remaining rectifiers) until the controller can send updated set points to the remaining rectifiers. This takes a couple communication cycles (several seconds) after which each rectifier would have a new set point of 37.5 amps for a total of 150 amps. The total current limit of the rectifiers should not be set such that the loss of the redundant rectifiers will cause this temporary set point to drop below the actual maximum expected load. If batteries are used on the rectifier output, the batteries should support the load until the current limit set points can be re-established due to loss of a rectifier.

NCU Start Wizard

For initial startup, you can perform the Start Wizard from the local keypad and display to enter basic programmable parameters in one session. Refer to the “Start Wizard” section in the NCU Controller User Manual (UM1M830BNA).

Verifying the Configuration File

Your NCU was programmed with a configuration file that sets all adjustable parameters. The version number of the configuration file can be found on the configuration drawing (C-drawing) that is supplied with your power system documentation, and on a label located on the NCU. You can verify that the correct configuration file has been loaded into your NCU by performing the following procedure.

Procedure

- With the Main Menu displayed, press **ESC**. A screen displays the NCU name, serial number, IP number, software version, hardware version, and configuration version number.
- Press **ESC** to return to the Main Menu.

Checking Basic System Settings

Navigate through the controller menus and submenus to check system settings. You can adjust any parameter as required. Note that these settings can also be checked (and changed if required) via the WEB Interface. Refer also to “NCU Start Wizard” on page 53.



NOTE! Repeatedly press the “ESC” key to return in reverse order level by level from any submenu until the Main Menu appears.

Procedure

1. **To Select a Sub-Menu:**
Press the UP and DOWN keys to highlight the desired sub-menu. Press the ENT key to enter the selected sub-menu.
2. **To Select a User:**
To select a User, use the UP and DOWN keys to move the cursor to the Select User field. Press ENT. Use the UP and DOWN keys to select a User previously programmed into the NCU. Press ENT to select the User. Note that only Users programmed into the NCU are shown. Users are programmed via the Web Interface. The default User is admin.
3. **To Enter a Password:**
If a password screen opens, a password must be entered to allow the User to make adjustments. To enter a password, use the UP and DOWN keys to move the cursor to the Enter Password field. Press ENT. Use the UP and DOWN keys to choose a character. Press ENT to accept and move to the next character. Continue this process until all characters are entered. Press ENT again to accept the password. The default password is 640275.
4. **To Change a Parameter:**
Press the UP and DOWN keys to move up and down the list of parameters. Press ENT to select the parameter. Press the UP and DOWN keys to change the parameter. Press ENT to make the change. Press ESC to cancel the change.
5. Table 7.1 shows the menu navigation for some basic settings. Refer to the separate NCU Controller User Manual (UM1M830BNA) supplied with your power system for complete Local Display menus.

Table 7.1: NCU Basic Settings Menu Navigation

Parameter	Menu Navigation
Date	Main Menu / Settings Icon / Sys Settings / Date.
Time	Main Menu / Settings Icon / Sys Settings / Time.
IP Communications Parameters (IP address, subnet mask address, gateway address)	Main Menu / Settings Icon / Comm Settings / enter parameters.
Float Voltage	Main Menu / Settings Icon / Batt Settings / Charge / Float Volt(R).
Equalize Voltage	Main Menu / Settings Icon / Batt Settings / Charge / EQ Voltage(R).
Battery Current Limit	Main Menu / Settings Icon / Batt Settings / Curr Limit Mode and Batt Curr Limit.
Battery Capacity	Main Menu / Settings Icon / Batt Settings / Batt1 Settings or Batt2 Settings / Rated Capacity.
BTRM Feature	Web Menu Navigation Only: Settings Menu / Battery Tab.
Battery Charge Temperature Compensation	Main Menu / Settings Icon / Batt Settings / Temp Comp (enter parameters).
HVSD Limit	Web Menu Navigation Only: Settings Menu / Rectifiers Tab / HVSD (set to enabled) then set HVSD Limit.
Rectifier Current Limit	Main Menu / Settings Icon / Rect Settings / Current Limit (set to enabled) then set Curr Limit Pt.
Over Voltage Alarm 1	Main Menu / Settings Icon / Other Settings / Over Voltage 1.
Over Voltage Alarm 2	Main Menu / Settings Icon / Other Settings / Over Voltage 2.
Under Voltage Alarm 1	Main Menu / Settings Icon / Other Settings / Under Voltage 1.
Under Voltage Alarm 2	Main Menu / Settings Icon / Other Settings / Under Voltage 2.

Changing Battery Capacity Rating in the NCU

NOTE! After setting the battery capacity, the User should also reset the battery capacity (battery must be fully charged).

1. Change the battery capacity setting of the NCU to match the battery connected to the power system. Refer to the NCU Controller User Manual (UM1M830BNA) for detailed instructions.

Local Menu Navigation:

Main Menu / Settings Icon / Batt Settings / Batt1 Settings or Batt2 Settings / Rated Capacity.

Web Menu Navigation:

Settings Menu / Battery Tab / Batt1 Rated Capacity and Batt2 Rated Capacity.

2. Reset the battery capacity (resets the battery capacity calculation).



NOTE! Only reset the battery capacity when the battery is fully charged; otherwise, the battery charge status may not be accurate.

Local Menu Navigation:

Main Menu / Settings Icon / Batt Settings / Basic Settings / Reset Batt Cap.

Web Menu Navigation:

Settings Menu / Battery Tab / Reset Battery Capacity.

Configuring the NCU Identification of Rectifiers and Assigning which Input Feed is Connected to the Rectifiers

When rectifiers are all installed prior to applying power and starting the system, the order in which the NCU identifies the rectifiers is by serial number (lowest serial number is Rect 1, next lowest is Rect 2, etc.). If you prefer the NCU to identify the rectifiers by position in the system, perform the following procedure.

Upon power up, the NCU arbitrarily assigns Feed AC1, AC2, or AC3 to each rectifier. This assignment is used to display rectifier AC input feed voltage(s). The User may reassign the feed to each rectifier per your specific installation by following the procedure below.

Local Menu Navigation:

None.

Web Menu Navigation:

Refer to the NCU Instructions (UM1M830BNA) for detailed instructions.

Configuring the NCU Identification of Converters

When rectifiers are all installed prior to applying power and starting the system, the order in which the NCU identifies the converters is by serial number (lowest serial number is Conv 1, next lowest is Conv 2, etc.). If you prefer the NCU to identify the converters by position in the system, perform the following procedure.

Local Menu Navigation:

None.

Web Menu Navigation:

Refer to the NCU Instructions (UM1M830BNA) for detailed instructions.

NCU Alarm Relay Check

To verify operation of the external alarm relays, use the NCU alarm relay test feature. Refer to the NCU Controller User Manual (UM1M830BNA) for instructions in using this feature.









NOTE! The relays may be preprogrammed for specific functions. Refer to the configuration drawing (C-drawing) supplied with your system for your system's specific configuration.

7.6 Checking System Status

Procedure

1. Observe the status of the indicators located on the controller and rectifiers. If the system is operating normally, the status of these is as shown in Table 7.2.

Table 7.2: Status and Alarm Indicators

Component	Indicator	Indicator	Normal State
NCU Controller		Status (Green)	On
		Minor Alarm (Yellow)	Off
		Critical or Major Alarm (Red)	Off
Rectifier Modules		Power (Green)	On
		Protection (Yellow)	Off
		Alarm (Red)	Off

7.7 Final Steps

Procedure

1. If any controller configuration settings were changed, refer to the NCU Controller User Manual (UM1M830BNA) and save a copy of the configuration file. This file can be used to restore the controller settings, if required, at a later date.



NOTE! Provided on a USB drive furnished with the system is a controller configuration drawing (C-drawing) and the controller configuration files loaded into the controller as shipped.

2. Close and secure the distribution cabinet's front door.
3. Verify all rectifier modules and the controller are fully seated, latched, and the latch handle screws secured.
4. Verify there are no external alarms and the local indicators are as shown in Table 7.2.

Connect with Vertiv on Social Media



<https://www.facebook.com/vertiv/>



<https://www.instagram.com/vertiv/>



<https://www.linkedin.com/company/vertiv/>



<https://www.x.com/vertiv/>



Vertiv.com | Vertiv Headquarters, 505 N Cleveland Ave, Westerville, OH 43082, USA

© 2024 Vertiv Group Corp. All rights reserved. Vertiv™ and the Vertiv logo are trademarks or registered trademarks of Vertiv Group Corp. All other names and logos referred to are trade names, trademarks or registered trademarks of their respective owners. While every precaution has been taken to ensure accuracy and completeness here, Vertiv Group Corp. assumes no responsibility, and disclaims all liability, for damages resulting from use of this information or for any errors or omissions.