

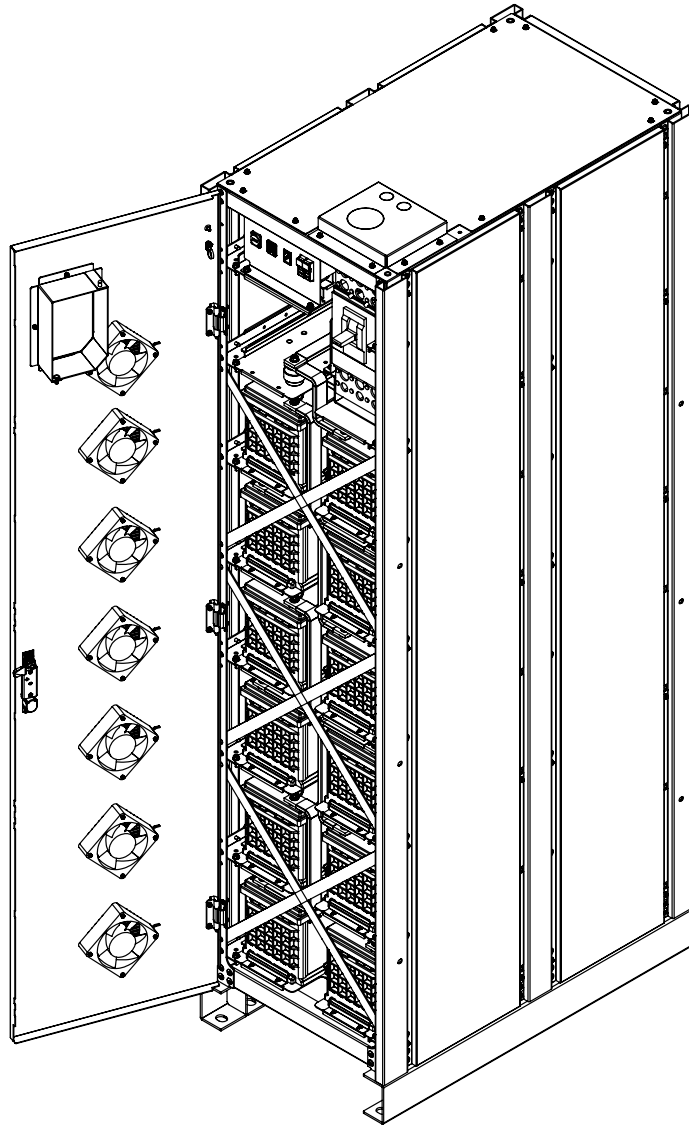

BC Series UPS Battery Cabinets

BC 2



*BC 2 UPS
Battery Cabinet*

Table of Contents

4	Introduction
4	Proprietary Information
4	Support
4	Support Contacts
4	Returns
4	About this Manual
5	Save this Manual
5	Disclaimer
6	Safety
6	Safety Symbols
7	Battery Safety
8	Battery Warnings and Cautions
8	Specifications
9	Safety Precautions
9	Tools
10	Précautions de sécurité
10	Outils
11	Shipping and Unpacking
12	Placement and Bolt Down
12	Additional Inspection
13	Field Connections
17	Appendix A
18	Appendix B
19	Appendix C
20	Notes

Introduction

Proprietary Information

This document contains information that is confidential and proprietary to ZincFive, Inc. It may not be reproduced, distributed, or translated in any other language, in whole or in part, without written approval from ZincFive and/or its associated partners.

Support

Support Contacts

For technical support, please contact a ZincFive support representative:

Support Phone: 888.517.7776

Support Email: support@zincfive.com

Support Website: zincfive.com/support

Returns

For product returns, please contact a ZincFive support representative to obtain a return material authorization (RMA).

ZincFive, Inc.
20170 SW 112th Ave.
Tualatin, Oregon 97062

Returns Email: support@zincfive.com
Support Phone: 888.517.7776

Customer is responsible to properly package product for return.. ZincFive does not warranty product damage from return shipping unless it is shipped in approved packaging.

About this Manual

This manual contains information to help owners and operators understand how to safely and properly prepare, install and operate the ZincFive batteries.

Instructions in this manual must be followed to ensure proper installation, operation and maintenance of the batteries in accordance with the Limited Warranty.

Save this Manual

This manual provides guidelines for safe and reliable battery operation. Save this manual, it contains important installation and operating instructions. If you have any questions about the safe installation, operation, or maintenance of the batteries, contact a ZincFive support representative. (visit zincfive.com/support or call 888-517-7776).

Disclaimer

While efforts have been made to ensure the accuracy and validity of information contained in the document, ZincFive assumes no responsibility and disclaims all liability for any errors and/or omissions that may be contained herein.

Due to possible changes and/or updates to component design and software applications, this document, completely or in part may become obsolete or out-of-date until a subsequent revision is released by ZincFive.

IMPORTANT SAFETY INSTRUCTIONS - SAVE THESE INSTRUCTIONS

THIS MANUAL CONTAINS IMPORTANT INSTRUCTIONS AND WARNINGS FOR ZINCFIVE BC SERIES UPS BATTERY CABINET THAT SHOULD BE FOLLOWED DURING INSTALLATION, OPERATION, STORAGE AND MAINTENANCE OF THE UPS AND BATTERIES. FAILURE TO HEED THESE INSTRUCTIONS AND WARNINGS WILL VOID YOUR WARRANTY.

Safety

Safety Symbols

ZincFive BC Series UPS Battery Cabinet are carefully designed and manufactured to ensure that they are safe and reliable products when used properly. To ensure the safe and proper use of ZincFive BC Series UPS Battery Cabinet, the following symbols are used throughout this manual or on the equipment. Operators, buyers, and technicians must observe each occurrence of these symbols as they appear throughout the document. Only qualified personnel should carry out instructions accompanied by these symbols.



DANGER Symbol

DANGER:

An electrical danger exists in this area. Use extreme caution at all times.

Symbole de danger

DANGER:

Un danger électrique existe dans ce domaine. Faites preuve d'une extrême prudence en tout temps.



CAUTION Symbol

CAUTION:

Important information or operating instructions. Follow them exactly.

Symbole d'attention

ATTENTION:

Informations importantes ou instructions d'exploitation. Suivez-les exactement.



Protective Earth/Ground Symbol







Used to designate a connection point to ground.

Symbole de terre de protection/ symbole de terre

Désigne un point de connexion à la terre.





Battery Safety



English

-  This battery must be installed by qualified personnel in accordance with the latest edition of the National Electrical Code ANSI/NFPA 70 and/or Canadian Electrical Code, Part I, CSA C22.1.
-  To prevent accidental shorts, shocks or electrocutions, never let water or any form of liquid touch, surround or enter the batteries.
-  Do not operate the batteries with damaged cables and wires. Defective cables and wires must be replaced before system installation. Prior to system installation, verify that all cables and wires are properly secured and connected. Faulty connections can interrupt operation and cause irreparable damage to this product.
-  Opening or attempting to dismantle the battery case will void the warranty and create a risk of electrical short circuit, burns or other physical harm
-  Do not dispose of batteries in a fire. The batteries may explode.
-  Do not open or mutilate batteries. Released electrolyte is harmful to the skin and eyes. It may be toxic.
-  A battery can present a risk of electrical shock and high short-circuit current. Contact with any part of a grounded battery can result in electrical shock. The following precautions should be observed when working on batteries:
 - a. Remove watches, rings, or other metal objects.
 - b. Use tools with insulated handles.
 - c. Wear rubber gloves and boots.
 - d. Do not lay tools or metal parts on top of batteries.
 - e. Disconnect charging source and load prior to installing or maintaining the battery.
 - f. Remove battery grounds during installation and maintenance to reduce likelihood of shock.
 - g. Remove the connection from ground if any part of the battery is determined to be grounded.

Note: Reference the Z5 13-80 H S F Safety Data Sheet for additional battery safety instructions.
<https://www.zincfive.com/subc-prismatic-material-safety-data-sheet>

French

-  Cette batterie doit être installée par un personnel qualifié conformément à la dernière édition du National Electrical Code ANSI/NFPA 70 et/ou du Code canadien de l'électricité, Partie I, CSA C22.1.
-  Pour éviter des courts-circuits, des chocs ou des électrocutions accidentels, ne jamais laisser de l'eau ou toute forme de liquide toucher, entourer ou pénétrer dans les piles.
-  Ne pas faire fonctionner les batteries avec des câbles et des fils endommagés. Les câbles et fils défectueux doivent être remplacés avant l'installation du système. Avant l'installation du système, vérifier que tous les câbles et fils sont correctement fixés et connectés. Des raccordements défectueux peuvent interrompre le fonctionnement et causer des dommages irréparables à ce produit.
-  L'ouverture ou la tentative de démontage du boîtier de la batterie annule la garantie et crée un risque de court-circuit électrique, de brûlures ou d'autres dommages physiques.

-  Ne pas jeter les batteries dans un feu. Elles peuvent exploser.
-  Ne pas ouvrir ou endommager les batteries. L'électrolyte libéré est nocif pour la peau et les yeux. Cela peut être toxique.
-  Une batterie peut présenter un risque de choc électrique et de courant de court-circuit élevé. Tout contact avec une partie quelconque d'une batterie mise à la terre peut entraîner un choc électrique. Les précautions suivantes doivent être observées lorsque vous travaillez sur des batteries :
 - a. Retirer toutes montres, bagues ou autres objets métalliques.
 - b. Utiliser des outils avec des poignées isolées.
 - c. Porter des gants et des bottes en caoutchouc.
 - d. Ne pas poser d'outils ou de pièces métalliques sur les batteries.
 - e. Déconnecter la source de charge et la charge avant d'installer ou d'entretenir la batterie.
 - f. Retirez les mises à la terre de la batterie pendant l'installation et l'entretien afin de réduire les risques de choc.
 - g. Retirer le raccordement à la terre si une partie de la batterie est déterminée comme étant mise à la terre.

Remarque : Référez-vous à la fiche de données de sécurité du Z5 13-80 H S F pour des instructions supplémentaires sur la sécurité des batteries.

zincfive.com/subc-prismaticmaterial-safety-data-sheet

Battery Warnings and Cautions

English

-  SHIELD EYES AT ALL TIMES WITH PROTECTIVE GEAR.
NO SPARKS. FLAMES. SMOKING.
ALKALINE ELECTROLYTES.
FLUSH EYES IMMEDIATELY WITH WATER.
WET NON-SPILLABLE.
DO NOT INCINERATE PUNCTURE OR IMPACT.
DO NOT SHORT CIRCUIT.
KEEP OUT OF REACH OF CHILDREN. DO NOT TIP. KEEP LEVEL.
WARNING: RISK OF FIRE, EXPLOSION, OR BURNS. DO NOT DISASSEMBLE, HEAT ABOVE 75°C, OR INCINERATE.

French

-  PROTÉGER LES YEUX EN TOUT TEMPS AVEC UN ÉQUIPEMENT DE PROTECTION.
PAS D'ÉTINCELLES OU DE FLAMMES. INTERDICTION DE FUMER.
ÉLECTROLYTES ALCALINS.
RINCER LES YEUX IMMÉDIATEMENT AVEC DE L'EAU.
HUMIDE ÉTANCHE.
NE PAS INCINÉRER, PERFORER OU COGNER.
NE PAS COURT-CIRCUITER.
TENIR HORS DE PORTÉE DES ENFANTS. NE PAS RENVERSER. MAINTENIR À NIVEAU.
ATTENTION : RISQUE D'INCENDIE, D'EXPLOSION OU DE BRÛLURES. NE PAS DÉMONTER, CHAUFFER AU-DESSUS DE 75°C, OU INCINÉRER.

Specifications

Refer to the ZincFive BC Series UPS Battery Cabinet data sheet for specifications.
zincfive.com/technical-documents

Safety Precautions



DANGER: HAZARD OF ELECTRIC SHOCK, EXPOSITION OR ARC FLASH

This product must be installed by qualified personnel according to the requirements defined below. This battery cabinet must be installed according to local and national regulations. Install the battery cabinet according to the following standards (depending on your local area):

- **National Electrical Code NFPA 70**
- **Canadian Electrical Code CSA C22.1**

The battery cabinet must be installed in a temperature controlled area free of conductive contaminants. Install on a level, solid surface (e.g. concrete or floor stand) that can support the weight of the system.

Follow all safety precautions when working on this system and always wear proper safety equipment including eye protection.

Notice: To limit drift in SOC with extended storage, the batteries must not be stored more than six months without recharging.

If attached to a UPS that remains de-energized for a long period ZincFive recommends you energize the UPS system every six months for a 12 hour period in order to recharge the batteries.

HIGH VOLTAGE: The Battery Cabinet Voltage varies by model between **370Vdc - 596Vdc**

MAXIMUM FAULT RATING (BREAKER): 20kA, 35kA, and 50kA options (instantaneous trip <10mS for any current >=7800A)

ARC FLASH DETAILS: Incident Energy at: 18in, Min. Arc Rating: 20 cal/cm², Arc Flash Boundary: 72.5in

MAXIMUM SHORT CIRCUIT RATING (BATTERY): 5400A

Tools

Use insulated tools for all installation and maintenance. The batteries and all bolts come pre-torqued and marked. The tools needed for final installation include:

- An insulated Flat Head Screwdriver and wrench: For installation of AC wires to terminal block and to tighten cord grips.
- Insulated 8mm or 5/16" Hex driver bit: For DC Breaker termination.
- Long and short #2 Philips head screwdriver.
- Insulated Torque Wrench with crow's foot adapter and 10MM Socket: For Battery bolts.
- For cover, side panels, and GND screw a 8mm socket
- For the Faceplate a 10MM socket

Précautions de sécurité

DANGER : RISQUE DE CHOC ÉLECTRIQUE, D'EXPLOSION OU D'ÉCLAT D'ARC ÉLECTRIQUE

Ce produit doit être installé par un personnel qualifié conformément aux exigences définies ci-dessous. L'armoire de batterie doit être installée conformément aux règlements locaux et nationaux. Installez l'armoire de batterie selon les normes suivantes (en fonction de votre région) :

- **Code national de l'électricité NFPA 70**
- **Code canadien de l'électricité CSA C22.1**

L'armoire de batterie doit être installée dans une zone à température contrôlée exempte de contaminants conducteurs. Installez sur une surface plane, solide (par exemple, support en béton ou au sol) capable de supporter le poids du système.

Suivez toutes les précautions de sécurité lorsque vous travaillez sur le système et portez toujours l'équipement de sécurité approprié, notamment une protection oculaire.

Avis : Pour limiter la dérive de l'état de charge lors d'un entreposage de longue durée, il ne faut pas entreposer les batteries plus de six mois sans les recharger.

Si relié à une ASI qui reste inerte pendant une période prolongée, ZincFive vous recommande d'alimenter l'ASI tous les six mois pendant une période de 12 heures afin de recharger les batteries.

HAUTE TENSION : La tension d'armoire de batteries varie selon le modèle entre 370 V c.c et 596 V c.c.

VALEUR ASSIGNÉE DE RUPTURE MAXIMALE (DISJONCTEUR) : 20kA, 35kA, and 50kA options (déclenchement instantané < 10 mS pour tout courant $\geq 7\ 800$ A)

DÉTAILS DE L'ÉCLAT D'ARC ÉLECTRIQUE : Énergie incidente à : 18 po, Valeur assignée d'arc minimale : 20 cal/cm², Limite d'arc électrique : 72,5 po

TENUE MAXIMALE AU COURT-CIRCUIT (BATTERIE) : 5 400 A

Outils

Utilisez des outils isolés pour toute tâche d'installation et d'entretien. Les batteries et tous les boulons sont préserrés et marqués. Outils nécessaires pour l'installation finale :

- Un tournevis à tête plate isolé : Pour installer les fils c.a. au bornier.
- Embout de tournevis hexagonal isolé 8 mm ou 5/16 po pour le raccordement du disjoncteur c.c.
- Tournevis cruciforme no 2 long et court.
- Clé dynamométrique isolée avec douille de 10 mm : Pour les boulons de batterie.

Shipping and Unpacking

The Battery Cabinet comes fully assembled and is shipped in an Air Ride Truck to limit vibrational damage. The cabinet will be shipped upright on a pallet.

CAUTION: The Cabinet has a high center of gravity (39.2") – use caution when moving.

Upon arrival follow these steps:

1. Inspect the outside of the cabinet for damage prior to signing for release.

Visible Damage

- It is the responsibility of the person receiving the shipment to inventory and fully inspect all materials against the bill of lading or weigh bill IMMEDIATELY while the carrier representative is still present. Ensure that all items are accounted for, including number of skids and quantity of boxes. Also note any visible external damage that may have occurred during transit. Make all applicable notations on the delivery receipt before signing and file a damage report with the carrier.
- Examine the TILT and SHOCK sensor on the cabinet. Both are just notifications to show the unit may have been exposed to excessive forces and that inspection is required to ensure no damage was done. Units received should be accepted from the shipper, but the activation must be noted with the shipper at time of acceptance.

2. Remove foam wrap, protectors, and clear plastic over the battery cabinet.

3. There are NO strap downs on the batteries. Everything will remain secure in place.

4. Perform a visual inspection of the cabinet.

- a. Open the door and examine all the batteries/drawers to make sure everything is still secure and attached. Note: Drawers are locked in place with two bolts and will not pull out without those being removed.
- b. Check torque seal markers on batteries
- c. Concealed Damage
 - Immediately unpack the system and check for any concealed damage. Check the materials received against the detailed packing list to verify the quantity and the condition as complete and satisfactory.
 - Note observations of any liquid or crystallized electrolyte on the sides of the batteries.
- d. Return of Damaged Goods
 - For product returns, please contact a ZincFive support representative to obtain a return material authorization (RMA).

5. Save the packaging material in the event a return is needed. ZincFive does not warranty product damage from return shipping unless it is shipped in approved packaging. Carefully move the cabinet to the install location using necessary fork lift / pallet jack

- a. Remove bolts holding cabinet to pallet
- b. Spread forks as wide as possible when lifting.
- c. Keep as low as possible to keep center of gravity as low as possible.
- d. The cabinet has been designed to be movable while fully loaded with batteries.

NOTES:

- DO NOT LIFT from the top of the cabinet as it will not support the frame weight.
- Refer to Appendix A for additional moving details.



Figure 1. Palletized Battery Cabinet Packaging

ZincFive, Inc.
20170 SW 112th Ave.
Tualatin, Oregon 97062

Placement and Bolt Down

1. The Battery Cabinet has several bolt locations for securing to the floor.
 - Refer to figure below for Bolt Hole location.
2. The cabinet should be placed where it will be mounted, holes marked and 0.75 size bolts placed for anchoring the cabinet.
 - It may be necessary to remove the bottom tray with batteries from the frame to bolt down the cabinet.
3. Set cabinet in place with anchor bolts installed. Anchoring is the responsibility of customer and is site and seismic rating dependent, bolts are not provided.
4. Anchor the frame using appropriate size Nut and Bolts for the install location.
 - Anchor bolt hole dimension: 0.75"

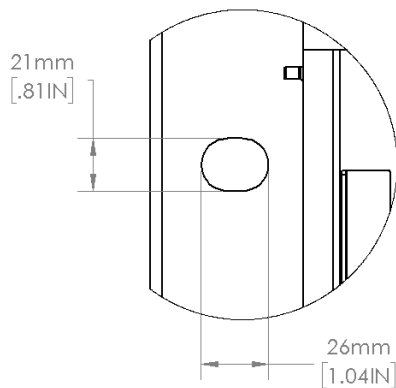
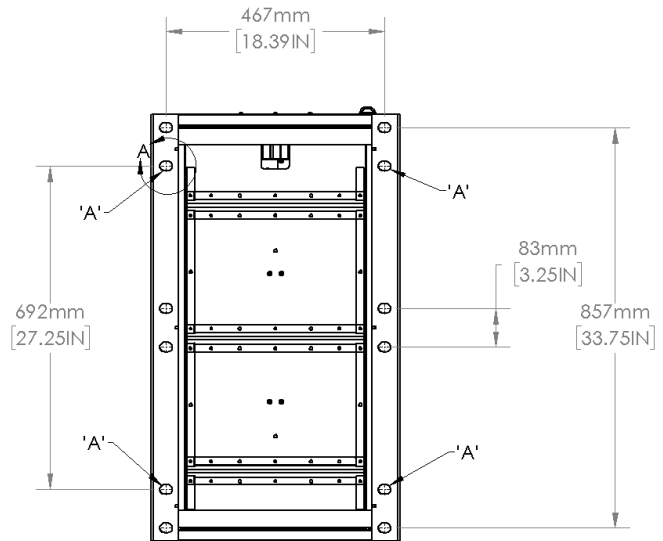

Figure 2. Cabinet Anchoring Locations



MOUNTING HOLES MARKED 'A' ARE REQUIRED FOR INSTALLATION. OTHER HOLES ARE OPTIONAL

Additional Inspection

Once the cabinet has been placed at its final install location perform a final inspection. Follow all safety precautions when working on this system and always wear proper safety equipment including eye protection. The cabinet voltage will exceed 500V between some of the batteries/components.

1. Inspection of the Batteries installed
 - a. Visual and torque inspection of battery string and cables. Examine torque markings and torque check all battery connections to ensure no loose connections.
Torque to: 9.1 +/- 0.9 N-m
 - b. Thoroughly inspect inside and outside of cabinet for damage.
 - c. If batteries require a re-torque, side panels may be removed to gain access or utilization of shelf tray support.
2. Battery cabinet wiring connections confirmation
 - a. Confirm no loose wiring and all connections still secure.
 - b. Check the BMS wiring on the BMS and Power shelves to confirm nothing has come loose during setting. Access is possible through the top panel as well as the slide out trays.
3. Battery voltage confirmation
 - Confirm all batteries are within +/-0.3V of one another. Since all batteries ship at 50% SOC State of Charge it is likely the batteries will be around 13.5 +/- 0.3V.

Field Connections

Below are the final connections required prior to going through the power ON sequence.

1. GROUND: Connect the GROUND wire to the GROUND NUT at the top of the cabinet.

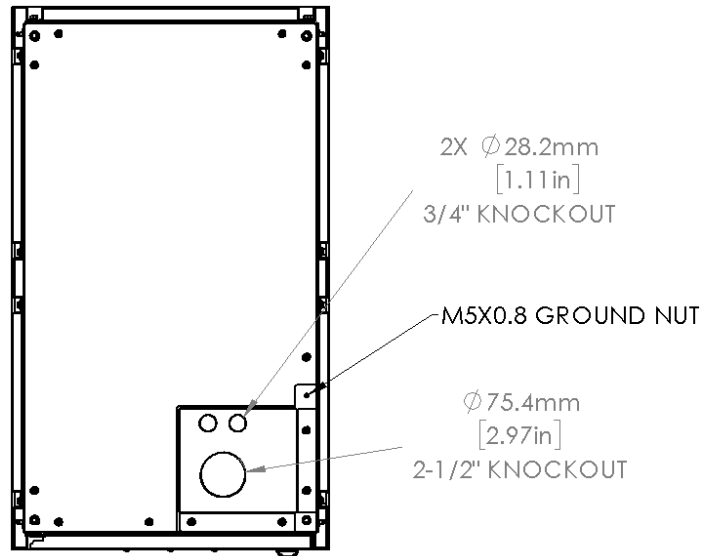

Figure 3. Knockout and Ground Details

2. DC: Connect the Positive and Negative conductors to the circuit breaker.
 - a. Make sure all power is off before making connection.
 - b. Positive conductor(s) will be attached to Terminal 1 (top of breaker)
 - c. Negative conductor(s) will be attached to Terminal 3 (top of breaker)
 - d. The circuit breaker torque and wire details:
 - Torque to: 442 in-lb/50N-m
 - Wire Details: Use 90C rated or higher, between #2/0 AWG - 500 kcmil Copper or Aluminum.
 - 2x 4/0 copper and use of cord grips is recommended for power rating. Should be installed by a licensed electrician and follow all local electrical codes.

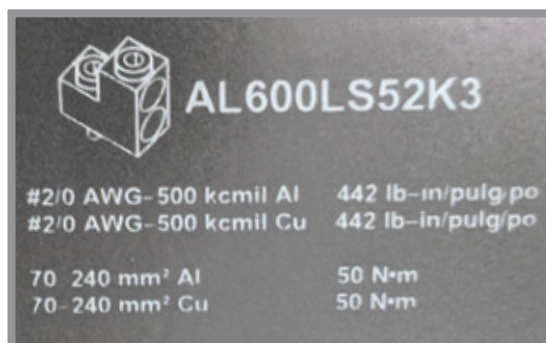

Figure 4. Breaker connection detail

e. Refer to Appendix C for the circuit breaker connection details.

3. AC: Connect the Ground, Neutral and Line to the terminal block for incoming AC. Refer to figures 5 and 6.

a. String AC and Neutral connect to fuse holders, strip wiring to 12MM. Torque screws to 1.7Nm (14.75 in-lbs).

Wire details: Use 75/90°C rated or higher between #14 to #10 AWG (2.5 to 5.0 mm²) solid/stranded copper.

b. AC GND connects to terminal block and requires 9MM stripped length.

Torque screws to 0.7Nm (6.19in-lb).

Faceplate will require removal (10mm) to access

Wire Details: Use 75/90°C rated or higher between #18 to #10 AWG (0.82 to 5.0 mm²) solid/stranded copper.

c. Note: The AC power MUST be supplied by a 100Watt UPS backed circuit. This powers the BMS and must remain powered when in backup during a power outage for the system to function.

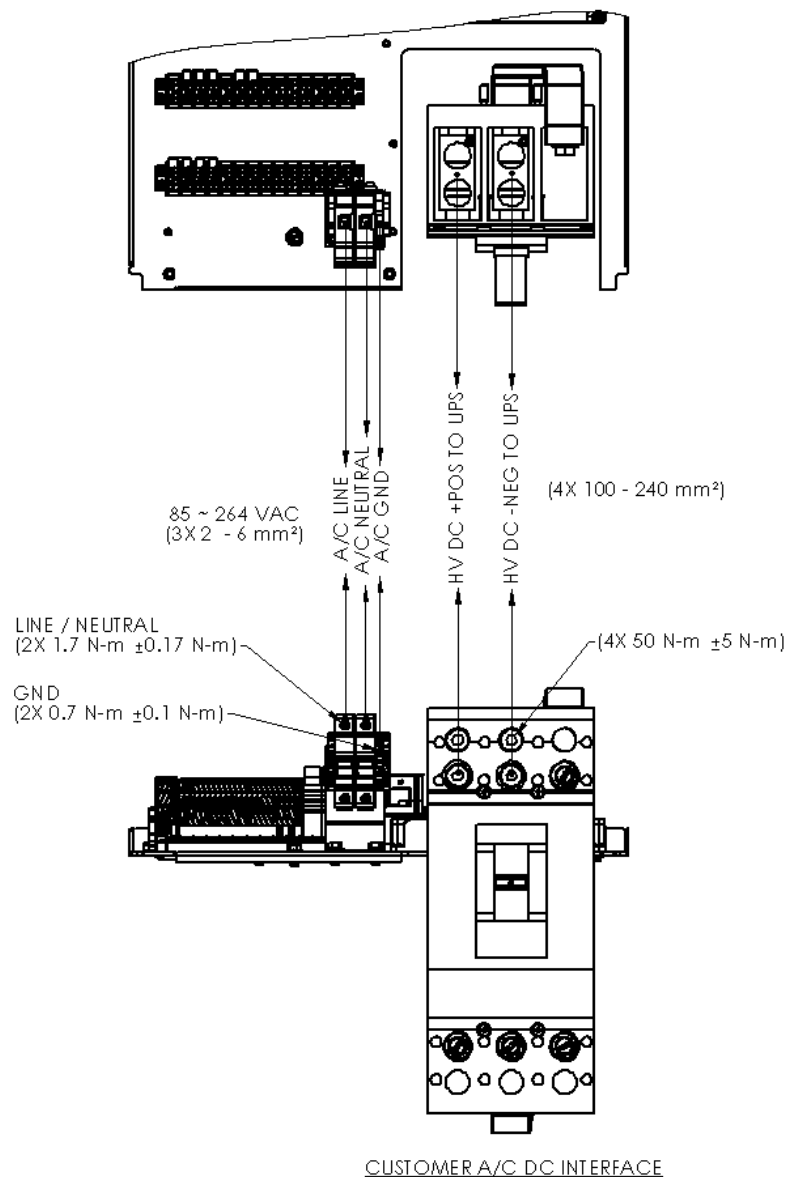



Figure 6. AC Input wiring (on right side at front of cabinet) and ON/OFF Switch

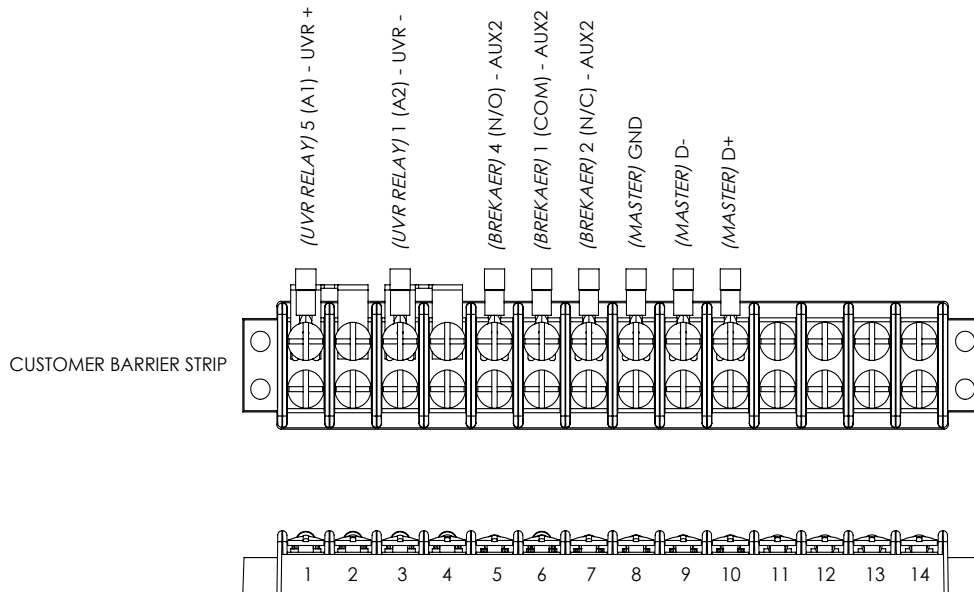

Figure 7. Pins 1,3 - UVR/Shunt Relay Access, Pins 5,6,7 (NO, COM, NC)

4. **UVR/SHUNT and AUX Access:** For UPS Systems that require an interface to the Circuit Breaker a customer accessible Terminal Block has been provided. Utilize 14-16 AWG UL approved wire and #6 spade connectors
 - a. UVR/SHUNT Relay – A relay coil is provided to facilitate external UPS connection to the battery circuit breaker, refer to the Figure. 7 for details. When the battery cabinet is configured with an UVR access, the circuit breaker cannot be turned on until UPS outputs its rated UVR voltage.
 - UVR/SHUNT Pin 1 = POSITIVE (+) Polarity
 - UVR/SHUNT Pin 3 = NEGATIVE (-) Polarity
 When the battery cabinet is configured with a shunt access, the circuit breaker will trip when the UPS outputs its rated shunt trip voltage.
 - b. AUX Circuit Breaker Access - Access to the Circuit Breaker status is provided via NO, NC and COM on the terminal block provided, see Figure. 7 for details.
5. Confirm all the harnesses to the BMS (top Box) are secure and the proper BX-50 to cabinet configuration has been completed by an authorized service personnel.

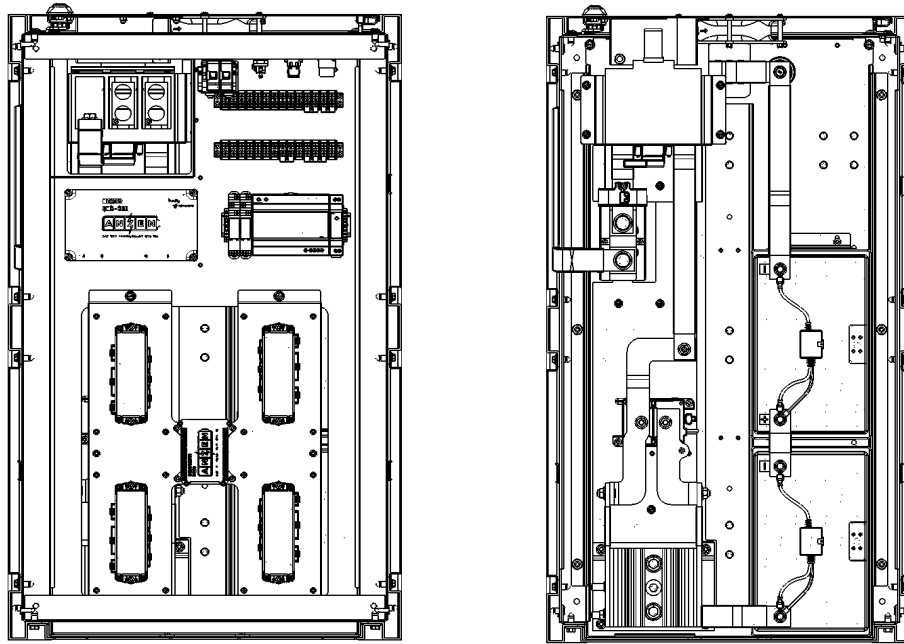

Figure 8. BMS and Power Tray Component Layout

6. Connect Ethernet cable to the Faceplate (top left panel inside door) if any remote monitoring of the Battery Cabinet is desired.
 - a. Configuration details are provided in the Operations Manual.

7. Apply AC Power to the system
 - a. It will take approximate 1-3 minutes for the BMS/R3000 to initialize and communicate with the server.
 - The network requirements needed for the R3000 to communicate with the Cloud or Local server:
 1. Local DHCP assigned IPv4 address
Inbound and Outbound permit TCP/443 and TCP/9101 to:
139.177.197.251
173.255.231.159
172.105.103.167
45.33.95.14
 2. Outbound permit tcp/3030, tcp/9101 to 172.105.23.38
 - b. If using the Cloud server, go to website to verify system is online: <https://manage.anzenbms.com/>
 - c. The system will begin in "Pre-standby state" until DC Power is applied
 - d. Confirm all batteries are within +/-0.3V of one another. Since all batteries ship between 30-50% State of Charge it is likely the batteries will be around 13.5 +/- 0.3V.

8. Enable the DC Power (UPS/Charger)
 - a. Ensure UPS or battery charger is set properly to manufacturers recommended settings for operation with the battery system.
 - b. Close the Breaker with the system in the "Pre-standby State." The system will immediately go into "Standby state" which means it is ready to function.
 - c. The system will transition immediately into a "Charge State" if the SOC is below 90% and battery temperatures are all > 15C and < 40C.

Note: If system was recently power cycled it may try to go into CHARGE state regardless of the SOC.

9. Perform a full or partial discharge (if possible) to confirm the system is working properly.
 - a. Confirm system shuts down properly with no system errors.

Appendix A

CAUTION:
HIGH CENTER OF MASS - USE CAUTION WHEN MOVING CABINET ONLY PERSONNEL, TRAINED TO MOVE HEAVY EQUIPMENT SHOULD HANDLE THESE BATTERY SYSTEMS.
USE A FORKLIFT OR SIMILAR DEVICE WITH APPROPRIATE LIFTING CAPACITY TO LIFT THE CABINET.
NOTE THE CENTER OF MASS LOCATION.
MOVE SLOWLY WHEN HANDLING. AVOID BOUNCING THE CABINET WHILE MOVING. THE CABINET COULD FALL FORWARD/REARWARD OR SIDEWAYS IF HANDLED ROUGHLY.
CABINETS ARE HEAVY. APPROPRIATELY RATED FORKLIFTS OR SIMILAR DEVICES SHOULD BE USED TO MOVE THE CABINET.
ENSURE FLOORS ARE LEVEL AND RATED TO CARRY THE WEIGHT OF THE CABINET.

GENERAL NOTES:
ONLY QUALIFIED TECHNICIANS SHOULD PERFORM INSTALLATION OR MAINTENANCE OF THIS BATTERY SYSTEM.
ALL TOOLS SHOULD BE INSULATED TO PREVENT ELECTRICAL SHOCK.
OPEN DISCONNECTS BEFORE INSTALLATION OR MAINTENANCE.
CHECK DC VOLTAGE AT BATTERY OUTPUT AND UPS OUTPUT TO ENSURE PROPER POLARITY BEFORE MAKING FINAL CONNECTIONS.

- PROCEDURE FOR BATTERY CABINET INSTALLATION:**
1. REMOVE SIDE PANELS AND TIGHTEN ALL ELECTRICAL POWER CONNECTIONS ON BATTERY TERMINALS UPON DELIVERY OF CABINET. SEE SHEETS 5 AND 6 FOR ADDITIONAL INFORMATION.
 2. INSTALL FLOOR ANCHORS OR DRILL FLOOR HOLES TO ALIGN WITH CABINET AS SHOWN ON SHEET 2.
 3. MOVE CABINET INTO POSITION OVER OR ONTO FLOOR ANCHORS AND INSTALL ANCHORS.
 4. INSTALL ANY ADDITIONAL ADJACENT CABINETS AND FASTENERS THEM TOGETHER THRU THE CORNER POSTS. REFER TO SHEET 4 FOR ADDITIONAL INFORMATION.
 5. INSTALL THE BUSBARS AS SHOWN ON SHEETS 7 AND 8.
 6. ROUTE AND INSTALL THE DATA CABLES AS SHOWN ON SHEETS 7-13.
 7. SEE SCHEMATIC AND BARRIER STRIP DETAILS ON SHEETS 14 AND 15 FOR ADDITIONAL INFORMATION.
 8. INSTALL THE DOORS AND LOCK WHEN NOT OPEN FOR MAINTENANCE.
- THE CABINET IS RATED FOR SEISMIC INSTALLATIONS ACCORDING TO IBC 2018. CONTACT ZINC/FIVE FOR SEISMIC INSTALLATION OPTIONS. INSTALL THE SEISMIC KIT ON THE FRONT OF THE CABINET AS NECESSARY. REFER TO SHEET 4 FOR ADDITIONAL INFORMATION.

CAUTION: HIGH VOLTAGE. RISK OF ELECTRICAL SHOCK
FOLLOW ALL SAFETY PRECAUTIONS WHEN WORKING ON THIS SYSTEM
ALWAYS WEAR PROPER PPE, INCLUDING EYE PROTECTION

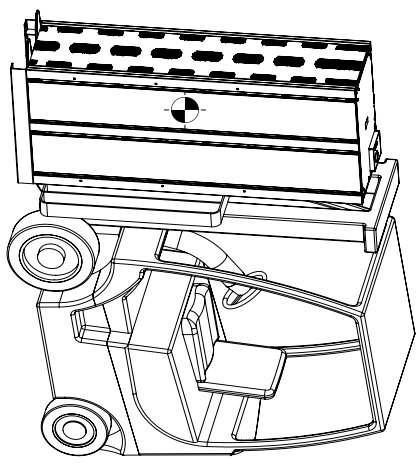

SPREAD FORKS TO FULL WIDTH OF CABINET
ENSURE FORKS AND INSERTED FULLY AND LONG ENOUGH TO SUPPORT ENTIRE DEPTH OF CABINET, OR CABINET MAY TIP DURING TRANSPORT.

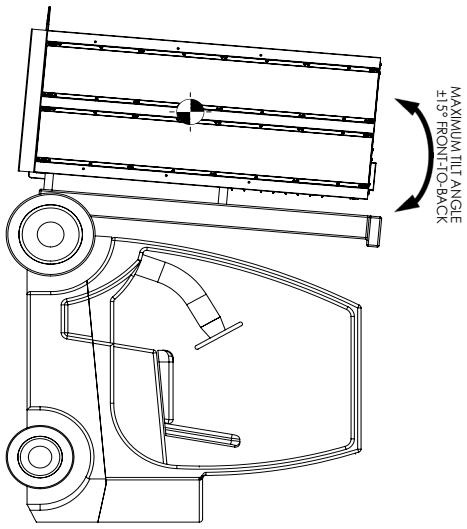
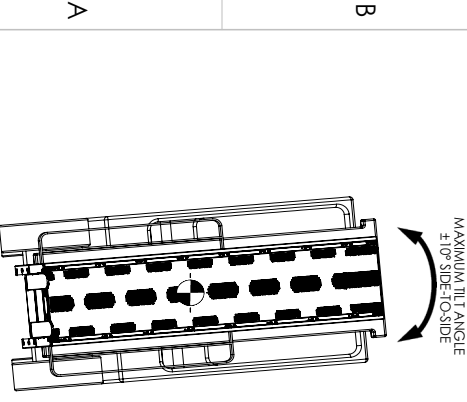

ZONE	REV.	DESCRIPTION	DATE	APPROVED
	H01	HW RELEASE	1/31/2023	

IMPORTANT
REVIEW THE DRAWINGS AND READ ALL INFORMATION BEFORE PROCEEDING WITH MOVING AND INSTALLING THE BATTERY CABINET.



TITLE:
ASY: ZF384SU GEN 1.5 BASE CABINET

UNLESS OTHERWISE SPECIFIED: DIMENSIONS ARE IN INCHES DIMENSIONS IN PARENT PARENTHESIS ARE METRIC EQUIVALENTS DIMENSIONS TO FACE UNLESS NOTED OTHERWISE DIMENSIONS TO CENTERLINE UNLESS NOTED OTHERWISE DIMENSIONS TO SURFACE UNLESS NOTED OTHERWISE DIMENSIONS TO CENTERLINE UNLESS NOTED OTHERWISE DIMENSIONS TO SURFACE UNLESS NOTED OTHERWISE DIMENSIONS TO CENTERLINE UNLESS NOTED OTHERWISE DIMENSIONS TO SURFACE UNLESS NOTED OTHERWISE	DATE: 1/31/2023	SCALE: 1:20 (W/HEIGHT: 350kg) SHEET 1 OF 18
DESIGNED BY: [Signature]	CHECKED BY: [Signature]	REV: H01
DRAWN BY: [Signature]	DATE: 1/31/2023	SYMBOLS: [Symbol]
APPROVED BY: [Signature]	DATE: 1/31/2023	REVISIONS: [Revision]
DATE: 1/31/2023	SCALE: 1:20 (W/HEIGHT: 350kg) SHEET 1 OF 18	

6 5 4 3 2 1

Appendix B

CAUTION: HIGH VOLTAGE, RISK OF ELECTRICAL SHOCK

- FOLLOW ALL SAFETY PRECAUTIONS WHEN WORKING ON THIS SYSTEM
- ALWAYS WEAR PROPER SAFETY EQUIPMENT INCLUDING EYE PROTECTION

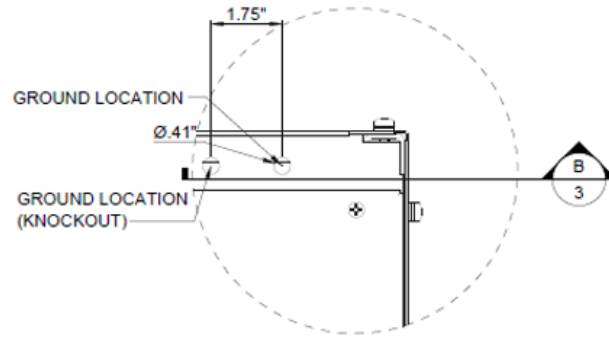

GROUNDING INSTALLATION (TOP OF CABINET)

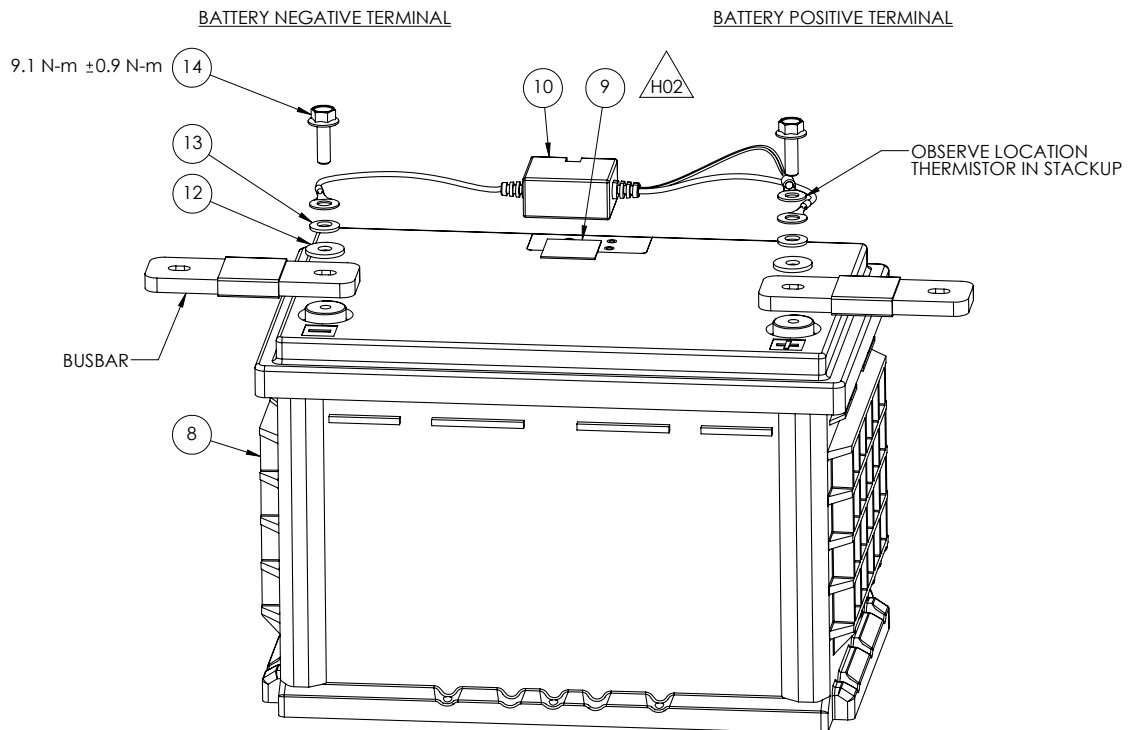

Appendix C

BREAKER INFORMATION		
BREAKER PART NUMBER	AMPS	24 VDC UVR PART NUMBER
LL137060D33ABU0	600	S29410
		242B AUX. CONTACTS PART NUMBER
		S29450

S29450 CHARACTERISTIC		
OPERATIONAL CURRENT	AC	DC
	24 V	6 A
48 V	6 A	2.5 A
110 V	6 A	0.6 A
220/240 V	6 A	-

CAUTION: HIGH VOLTAGE, RISK OF ELECTRICAL SHOCK

- FOLLOW ALL SAFETY PRECAUTIONS WHEN WORKING ON THIS SYSTEM
- ALWAYS WEAR PROPER SAFETY EQUIPMENT INCLUDING EYE PROTECTION

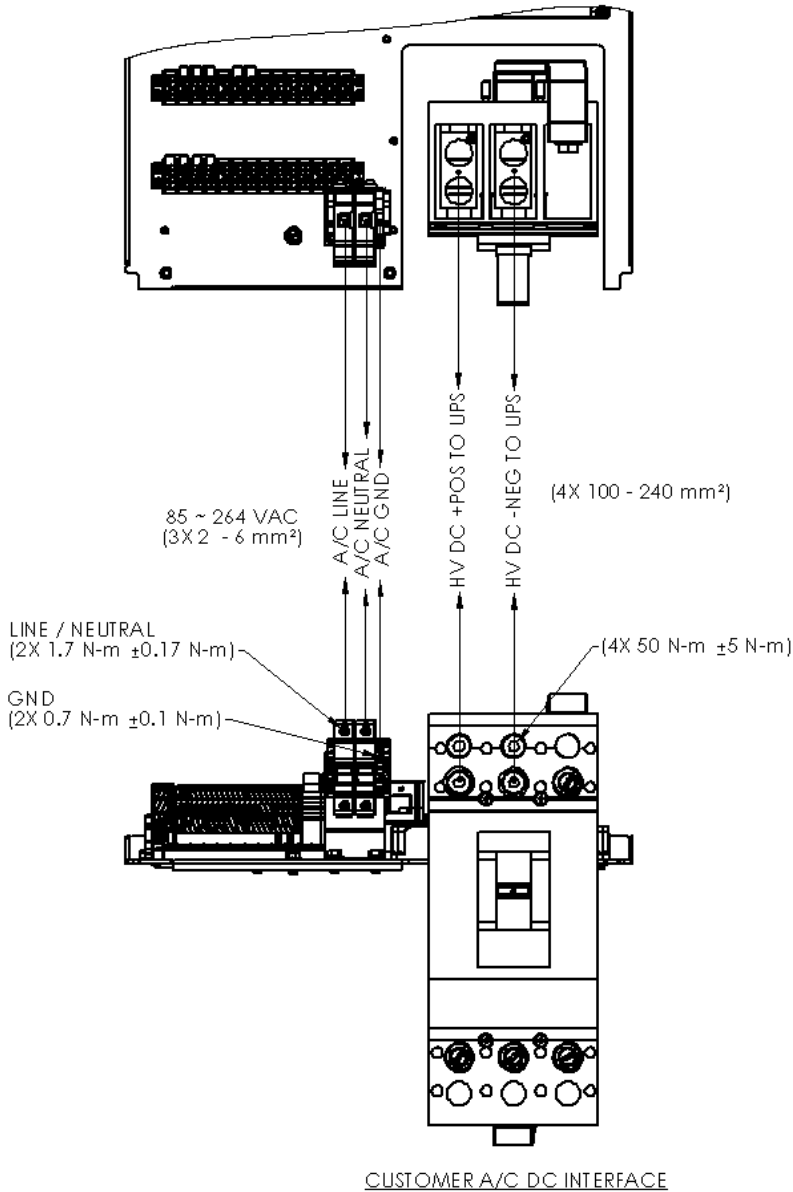

CUSTOMER A/C DC INTERFACE

LUG INFORMATION					
LUG PART NUMBER	CONDUCTOR SIZE	STRIP LENGTH	TORQUE	NECESSARY TOOLS	MANUFACTURER DOCUMENT LINK
AL60ULS5ZK3	2/0 AWG - 500 KCMIL	1.2 INCH	442 LB-IN	TORQUE WRENCH, RATED 500 IN-LBS 8 MM HEX WRENCH	https://download.schneider-electric.com/files?p_e=Instruction+sheet&file_Name=S1A14748.pdf&_Doc_Ref=S1A14748

Notes



ZincFive, Inc.
20170 SW 112th Ave.
Tualatin, Oregon 97062

zincfive.com/support
01100-00400-00104, rev H03