

LIEBERT® NPOWER™ BATTERY INTERFACE BOX

Product Specification/Installation Sheet

SAVE THESE INSTRUCTIONS

This manual contains important instructions that should be followed during installation of your Liebert Npower Battery Interface Board Box. Read this manual thoroughly before working with the DC system. Retain this manual for use by installing personnel.



WARNING

Risk of electric shock. Can cause personal injury or death.

The DC terminal voltage connected to this equipment will exceed 400VDC and is potentially lethal. Be constantly aware that the DC system contains high DC as well as AC voltage. Check for voltage with AC and DC voltmeters before making contact.

Special safety precautions are required for procedures involving handling, installing and maintaining the DC system. Only properly trained and qualified personnel wearing appropriate personal protective equipment should be involved in installing the Liebert Npower Battery Interface Board Box or preparing the system for installation.

Special care must be taken when working with the batteries associated with this equipment. Observe all DC safety precautions before working on or near the DC system.



WARNING

The following precautions must be observed when working on this equipment:

- Remove watches, rings and other metal objects.
- Use tools with insulated handles.
- Wear rubber gloves and boots.
- Do not lay tools or metal parts on top of batteries.
- Disconnect charging source prior to connecting or disconnecting DC terminals.
- Determine whether the DC source is grounded. If it is grounded, remove source of ground. Contact with any part of a grounded DC source can result in electrical shock. The likelihood of such shock will be reduced if such grounds are removed during installation and maintenance.

This unit complies with the limits for a Class A digital device, pursuant to Part 15 Subpart J of the FCC rules. These limits provide reasonable protection against harmful interference in a commercial environment. This unit generates, uses and radiates radio frequency energy and, if not installed and used in accordance with this instruction manual, may cause harmful interference to radio communications. Operation of this unit in a residential area may cause harmful interference that the user must correct at his own expense.

Placement and Cable Entry

The Liebert Battery Interface Box should be installed near the DC disconnect. The location should allow access to the box and allow the front door to be opened for service. Access to the Battery Interface Board (BIB), fuse disconnects and terminal blocks are behind the front door. See **Figure 1** for cable entry layout.

Control Connection

Each Liebert Npower Battery Interface Board Box contains a Battery Interface Board (BIB). All DC systems must have their Battery Interface Boards' controls connected in series.



NOTE

Control cables must be routed away from high-voltage cables and busbars. Use recommended knockouts for installing all cables and use provided tie point to secure. See **Figure 2**.

NOTICE

Risk of improper installation. Can cause equipment damage.

During system commissioning, Emerson Network Power Liebert Services will verify the operation of the Liebert Npower UPS and the BIB. If another DC source is added to the system after commissioning, it is imperative that Liebert Services configure the UPS for the additional DC source.

Figure 1 Dimensions and layout

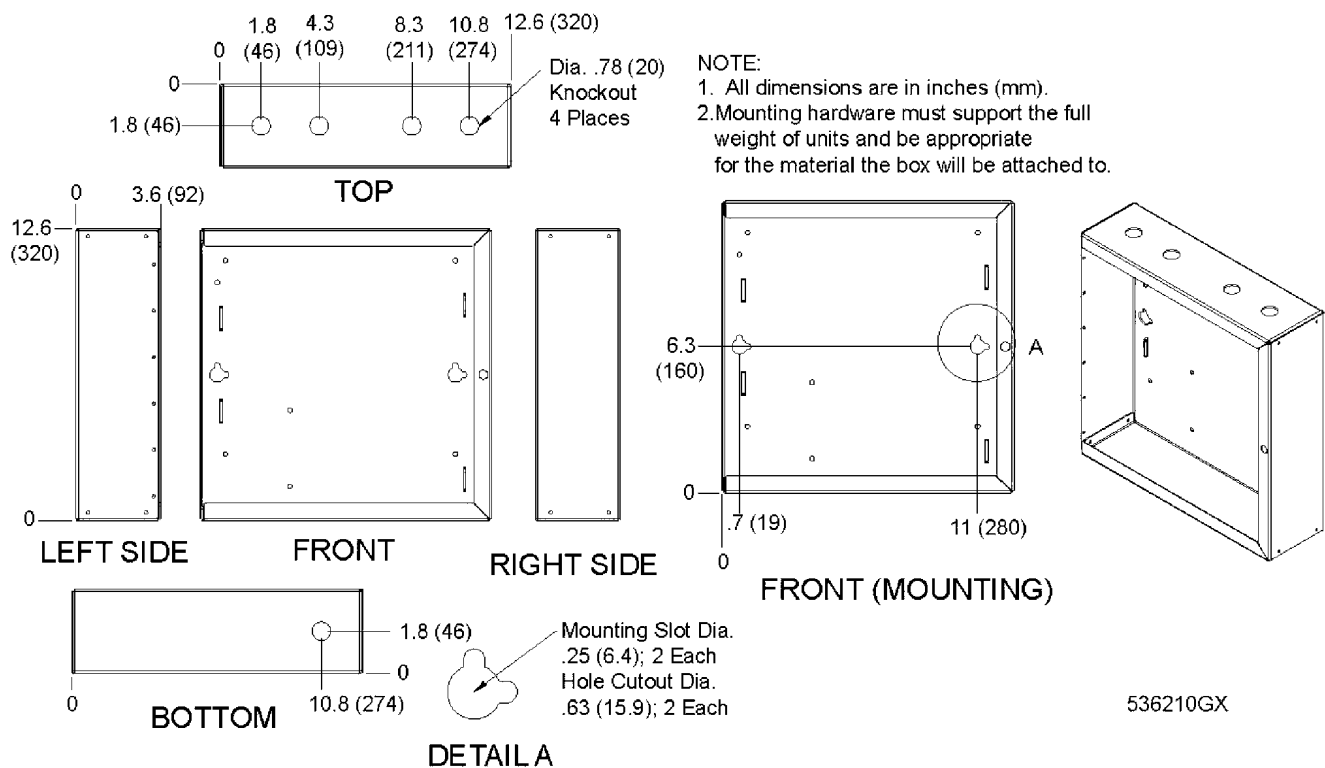
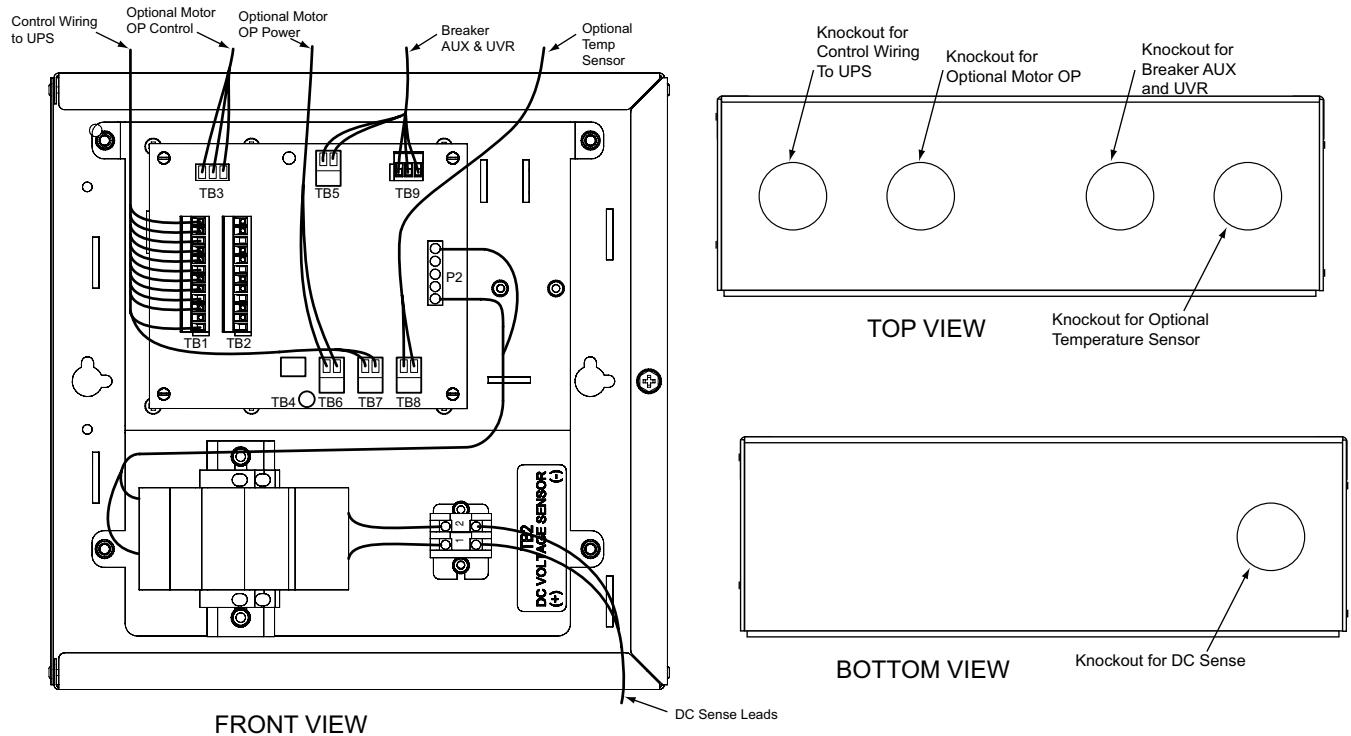

Table 1 Liebert Battery Interface Box specifications

Parameter	Values
DC Sense Volts, VDC	384-576
DC Sense Current, IDC	0.0002A
UVR Volts, VDC	24V
Dry Contacts Volts, VDC (Auxiliary Contacts)	24V
Dry Contacts Volts, VDC (Breaker Aux)	10mA
Mounting Hardware (supplied by others)	Must Support 30lb. (13.6kg)

DISCONTINUED PRODUCT

Figure 2 Control wiring routing



External Battery Room Temperature Sensor-Optional

Connecting an optional sensor to the BIB to monitor the ambient, room temperature will enable the Liebert Npower to perform temperature-compensation charging. The optional temperature sensor should be mounted in the area that will have the highest battery ambient temperature. Connect the Optional Room Temperature Sensor to TB8 on the BIB Board.

DC Sense Connections

Connecting the DC sense voltage wires will allow the Liebert Npower to display the DC source on the UPS display screen.

The DC source cabinet may require field-installed fuse protection; refer to national and local codes to verify whether fuse protection is required.

The DC sense wires must run from the most-positive DC voltage to the most-negative DC voltage.

DC Breaker Undervoltage Release (UVR) Contacts

If the DC breaker is used as a Module Battery Disconnect breaker (UPS will have control of the breaker), then the 24V UVR contacts must be run to the BIB.

DISCONTINUED PRODUCT

Figure 3 Wiring connections

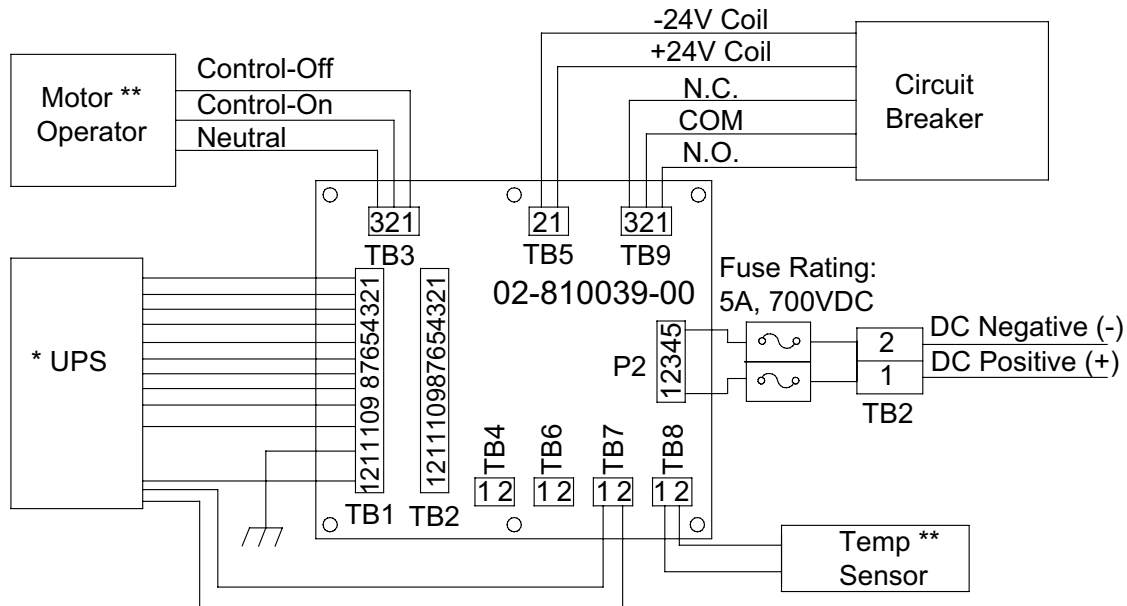

* Refer to UPS Installaton Manual
 ** Optional Equipment

545278P1
 Rev. 0

Table 2 Wire list

From	To	Description
NPWRBIB	NPWRBIB	—
BIB Board TB1 -11	Chassis Ground	—
NPWRBIB	UPS	—
BIB Board TB1-1	TB69-1	UVR Control 24VDC+
BIB Board TB1-2	TB69-2	UVR Control 24VDC--
BIB Board TB1-3	TB69-3	24 VDC
BIB Board TB1-4	TB69-4	**Motor Operator On
BIB Board TB1-5	TB69-5	**Motor Operator Off
BIB Board TB1 -6	TB69-6	Breaker Aux NO
BIB Board TB1-7	TB69-7	Breaker Aux COM
BIB Board TB1-8	TB69-8	Breaker Aux NC
BIB Board TB1-9	TB69-9	Logic Ground
BIB Board TB1-10	TB69-10	Batt Sensing +
BIB Board TB1 -12	TB69-12	Batt Sensing --
BIB Board TB7-1	TB70-1	**Battery Temp Sensor
BIB Board TB7-2	TB70-2	**Battery Temp Sensor
BIB Board TB6-1	TB73-11	**Motor Operator 120VAC
BIB Board TB6-2	TB73-12	**Motor Operator Neutral

** Optional equipment

From	To	Description
NPWRBIB	DC Breaker	—
TB2-1	Pos. from DC Source	DC Positive
TB2-2	Neg. from DC Source	DC Negative
BIB Board TB5-1	UVR +	UVR Control Pos
BIB Board TB5-2	UVR --	UVR Control Neg
BIB Board TB9-1	Aux NO	Aux NO
BIB Board TB9-2	Aux COM	Aux COM
BIB Board TB9-3	Aux NC	Aux NC
BIB Board TB3-1	Motor Operator Off	**Motor Operator Off
BIB Board TB3-2	Motor Operator On	**Motor Operator On
BIB Board TB3-3	Motor Operator Neutral	**Motor Operator Neutral
NPWRBIB	Temperature Sensor	—
BIB Board TB8-1	Temp Sensor TB1-1	**Battery Temp Sensor
BIB Board TB8-2	Temp Sensor TB1-2	**Battery Temp Sensor

Liebert Corporation

1050 Dearborn Drive Telephone: 1-800-877-9222
 P.O. Box 29186 Facsimile: 1-614-841-6022
 Columbus, OH 43229 www.liebert.com

SL-24548_REV0_07-11

© 2011 Liebert Corporation

All rights reserved throughout the world. Specifications subject to change without notice.

® Liebert is a registered trademark of Liebert Corporation. All names referred to are trademarks or registered trademarks of their respective owners.

DISCONTINUED PRODUCT