

**DISCONTINUED  
PRODUCT**

■ AC Power  
For Business-Critical Continuity

## Liebert NX™ UPS

Installation Manual—10-30kVA, 208V, 60Hz



 **Liebert**

  
**EMERSON**  
Network Power

DISCONTINUED  
PRODUCT

---

# TABLE OF CONTENTS

<b>IMPORTANT SAFETY INSTRUCTIONS</b> .....	<b>1</b>
<b>GLOSSARY OF SYMBOLS</b> .....	<b>3</b>
<b>1.0 INSTALLATION</b> .....	<b>4</b>
1.1 External Inspections .....	4
1.2 Internal Inspections .....	4
1.2.1 Storing for Delayed Installation .....	5
1.3 Preliminary Checks .....	5
1.3.1 Identification .....	5
1.4 UPS Location .....	5
1.4.1 Positioning the UPS .....	5
1.4.2 Environmental Considerations .....	5
1.4.3 Special Considerations for 1+N Systems .....	6
1.5 Considerations in Moving the NX .....	6
1.6 Mechanical Considerations .....	6
1.6.1 Clearances .....	7
1.6.2 Floor Installation .....	7
1.6.3 Cable Entry .....	7
1.6.4 Optional Cabinets .....	8
<b>2.0 ELECTRICAL CONNECTIONS</b> .....	<b>9</b>
2.1 Power Cabling .....	9
2.1.1 Cable Rating .....	9
2.1.2 UPS Input Configuration .....	10
2.1.3 Cabling Guidelines .....	10
2.1.4 Cable Connections .....	11
2.1.5 Safety Ground .....	12
2.1.6 Protective Devices .....	12
2.1.7 Cabling Procedure .....	13
2.2 Control Cables .....	14
2.2.1 Monitor Board Features .....	14
2.3 Dry Contacts .....	15
2.3.1 Input Dry Contacts .....	15
2.3.2 Maintenance Bypass Cabinet Interface .....	16
2.3.3 BCB Box Interface .....	16
2.3.4 Output Dry Contacts .....	17
2.3.5 EPO Input—Optional .....	17
<b>3.0 BATTERY INSTALLATION</b> .....	<b>19</b>
3.1 Introduction .....	19
3.2 Safety .....	19
3.3 UPS Batteries .....	19

3.4	External Battery Cabinet Installation . . . . .	20
3.4.1	Matching Battery Cabinets . . . . .	20
3.4.2	Connecting the Batteries . . . . .	20
3.4.3	Installation Considerations . . . . .	22
3.4.4	Connecting the Battery Cabinet to the UPS . . . . .	24
3.5	Non-Standard Batteries . . . . .	24
<b>4.0</b>	<b>MAINTENANCE BYPASS CABINET . . . . .</b>	<b>25</b>
4.1	Bypass Switch . . . . .	25
4.2	Normal (UPS) Mode . . . . .	25
4.3	Bypass Mode . . . . .	26
4.4	Maintenance Mode . . . . .	26
4.5	Locating the Cabinet . . . . .	26
4.6	Cable Installation . . . . .	26
4.6.1	Wiring Preparation . . . . .	26
4.6.2	Power Cable Installation . . . . .	27
4.6.3	Input/Output Wiring . . . . .	27
4.7	Bolting Cabinets Together . . . . .	29
<b>5.0</b>	<b>OPTIONS . . . . .</b>	<b>30</b>
5.1	Load Bus Synchronization . . . . .	30
5.1.1	Performance Requirements . . . . .	30
5.1.2	DBS Cable and Settings . . . . .	30
5.2	Configuring Parallel System Operation . . . . .	31
5.2.1	General . . . . .	31
5.2.2	Features of Parallel System . . . . .	31
5.2.3	Operating Principles . . . . .	32
5.2.4	Operation Modes Summary . . . . .	32
5.3	Installing Parallel System . . . . .	32
5.3.1	Conditions for Parallel System . . . . .	32
5.3.2	Cabinet Installation . . . . .	32
5.3.3	Preliminary Checks . . . . .	32
5.3.4	Protective Devices . . . . .	32
5.3.5	Power Cables . . . . .	33
5.3.6	Parallel Control Cables . . . . .	33
5.3.7	Emergency Power Off (EPO) . . . . .	35
5.4	Battery Circuit Breaker Box . . . . .	36
<b>6.0</b>	<b>UPS SPECIFICATIONS . . . . .</b>	<b>38</b>
6.1	Conformity and Standards . . . . .	38
6.2	UPS Environmental . . . . .	38
6.3	UPS Mechanical Characteristics . . . . .	38
6.4	UPS Electrical Characteristics . . . . .	39
6.4.1	Battery Manufacturers and Models . . . . .	40
6.4.2	Input Rectifier . . . . .	40
6.4.3	DC Intermediate Circuit . . . . .	40
6.4.4	Inverter Output . . . . .	41
6.4.5	Bypass Input . . . . .	41

<b>7.0</b>	<b>INSTALLATION DRAWINGS</b> . . . . .	<b>42</b>
<b>8.0</b>	<b>SPECIFICATIONS AND TECHNICAL DATA</b> . . . . .	<b>59</b>
8.1	Lug Size and Torque Requirements . . . . .	59
8.2	Cable Lengths: Floor to Connection Point Inside UPS . . . . .	70

## FIGURES

Figure 1	Cabinet arrangement . . . . .	8
Figure 2	Single module block diagram—dual input configuration . . . . .	10
Figure 3	Input busbars . . . . .	11
Figure 4	Battery fuses and connections . . . . .	11
Figure 5	Ground and neutral busbar connections . . . . .	12
Figure 6	Monitor board U2 . . . . .	14
Figure 7	Auxiliary terminal block detail (Monitoring Board) . . . . .	15
Figure 8	Input dry contacts . . . . .	15
Figure 9	Jumper connection for BCB interface . . . . .	16
Figure 10	Output dry contacts and EPO wiring for firmware before M170 . . . . .	17
Figure 11	EPO wiring for firmware M200 or later . . . . .	18
Figure 12	Battery cabinet—details . . . . .	20
Figure 13	Narrow battery cabinet, 27 in. (690mm) - rear view . . . . .	21
Figure 14	Wide battery cabinet, 57 in. (1488mm) - front view . . . . .	21
Figure 15	Internal cable wiring from battery cabinet to Liebert NX . . . . .	23
Figure 16	Battery tray and supports . . . . .	23
Figure 17	Single UPS with external Maintenance Bypass Cabinet—typical configuration . . . . .	25
Figure 18	Maintenance Bypass Cabinet—access plate removed . . . . .	26
Figure 19	Maintenance Bypass Cabinet wiring access panel . . . . .	27
Figure 20	Maintenance bypass control wire location . . . . .	28
Figure 21	Load Bus Synchronization cable connection . . . . .	30
Figure 22	1+N system block diagram . . . . .	31
Figure 23	Connecting '1+N' system parallel control cables . . . . .	33
Figure 24	Auxiliary dry contact cables for output breaker in multi-module system . . . . .	34
Figure 25	Dry contacts, multiple UPS modules with distribution panel . . . . .	34
Figure 26	Connecting EPO push button . . . . .	35
Figure 27	Battery circuit breaker box connections . . . . .	37
Figure 28	Dimensional view- front and left side views . . . . .	42
Figure 29	Dimensions continued—top and bottom views . . . . .	43
Figure 30	Main components—typical unit . . . . .	43
Figure 31	Cable connections . . . . .	44
Figure 32	Location of internal batteries . . . . .	45
Figure 33	Battery connections . . . . .	46
Figure 34	Battery cabinet interconnection . . . . .	47
Figure 35	Maintenance Bypass interconnection . . . . .	48
Figure 36	NX 1+1 parallel cabinet interconnections . . . . .	49
Figure 37	Lineup detail—SlimLine distribution cabinet to NX . . . . .	50
Figure 38	Lineup detail—1+N Type A connection to NX . . . . .	51
Figure 39	Lineup detail—1+N Type A1 connection to NX . . . . .	52
Figure 40	Lineup detail—1+N Type B connection to NX . . . . .	53
Figure 41	Lineup detail—1+N Type B1 connection to NX . . . . .	54
Figure 42	Lineup detail—1+N Type C connection to NX . . . . .	55
Figure 43	Lineup detail—1+N Type C1 connection to NX . . . . .	56
Figure 44	Lineup detail—1+N Type D connection to NX . . . . .	57
Figure 45	SlimLine locations . . . . .	58

---

## TABLES

Table 1	Input dry contacts at X3 . . . . .	15
Table 2	Maintenance bypass cabinet interface . . . . .	16
Table 3	BCB box interface . . . . .	16
Table 4	Output dry contact relays . . . . .	17
Table 5	EPO input contact relays . . . . .	17
Table 6	EPO input contact relays . . . . .	18
Table 7	Available battery circuit breaker boxes . . . . .	36
Table 8	Environmental characteristics . . . . .	38
Table 9	Mechanical characteristics . . . . .	38
Table 10	UPS terminal . . . . .	39
Table 11	Approved batteries . . . . .	40
Table 12	Rectifier input power . . . . .	40
Table 13	DC intermediate circuit . . . . .	40
Table 14	Inverter output . . . . .	41
Table 15	Bypass input . . . . .	41
Table 16	Liebert -supplied interconnect wiring . . . . .	47
Table 17	Liebert-supplied interconnect wiring for Maintenance Bypass Cabinet . . . . .	48
Table 18	Liebert-supplied interconnect wiring . . . . .	49
Table 19	Liebert-supplied interconnect wiring—SlimLine distribution cabinet to NX . . . . .	50
Table 20	Interconnect wiring—1+N Type A connection to NX . . . . .	51
Table 21	Interconnect wiring—1+N Type A1 connection to NX . . . . .	52
Table 22	Interconnect wiring—1+N Type B connection to NX . . . . .	53
Table 23	Interconnect wiring—1+N Type B1 connection to NX . . . . .	54
Table 24	Interconnect wiring—1+N Type C connection to NX . . . . .	55
Table 25	Interconnect wiring—1+N Type C1 connection to NX . . . . .	56
Table 26	Interconnect wiring—1+N Type D connection to NX . . . . .	57
Table 27	Torque specifications . . . . .	59
Table 28	Battery torque rating . . . . .	59
Table 29	Maintenance bypass cabinet electrical data (single input) . . . . .	60
Table 30	Maintenance bypass cabinet electrical data (dual input) . . . . .	61
Table 31	Multi-module bypass cabinet electrical data . . . . .	62
Table 32	Maintenance bypass cabinet lug sizes . . . . .	68
Table 33	Maintenance Bypass Cabinet weights . . . . .	69
Table 34	Battery cabinet physical characteristics . . . . .	69
Table 35	Maintenance bypass cabinet dimensions . . . . .	70
Table 36	Multi-module paralleling cabinet dimensions . . . . .	70
Table 37	Distance to connection points on the NX UPS . . . . .	70

---

## IMPORTANT SAFETY INSTRUCTIONS

---

### SAVE THESE INSTRUCTIONS

This manual contains important instructions that should be followed during installation of your Liebert NX™ UPS and batteries.

Read this manual thoroughly, paying special attention to the sections that apply to your installation, before working with the UPS. **Retain this manual for use by installing personnel.**



#### WARNING

Exercise extreme care when handling UPS cabinets to avoid equipment damage or injury to personnel. The UPS module weight ranges from 850 to 1400 lb. (386 to 635kg).

Determine unit weight and locate center of gravity symbols  before handling the UPS. Test lift and balance the cabinet before transporting. Never tilt equipment more than 15 degrees from vertical.

Battery manufacturers supply details of the necessary precautions to be observed when working on, or in the vicinity of, a large bank of battery cells. These precautions should be followed implicitly at all times.

Follow all battery safety precautions when installing, charging or servicing batteries. In addition to the hazard of electric shock, gas produced by batteries can be explosive and sulfuric acid can cause severe burns. When connected, the nominal battery voltage is 288VDC and is potentially lethal.

In case of fire involving electrical equipment, use only carbon dioxide fire extinguishers or those approved for use in fighting electrical fires.

Extreme caution is required when performing maintenance.

Be constantly aware that the UPS system contains high DC as well as AC voltages.

Check for voltage with both AC and DC voltmeters prior to making contact.



#### WARNING

As with other types of high power equipment, dangerous voltages are present within the UPS and battery enclosure. The risk of contact with these voltages is minimized as the live component parts are housed behind a hinged, lockable door. Further internal safety screens make the equipment protected to IP20 standards.

No risk exists to any personnel when operating the equipment in the normal manner, following the recommended operating procedures.

All equipment maintenance and servicing procedures involve internal access and should be carried out only by trained personnel.



#### WARNING

High ground leakage current: Ground connection is essential before connecting the input supply.

This equipment must be grounded in accordance with local electrical codes.

Maximum load must not exceed that shown on the UPS rating label.



## CAUTION

This equipment is fitted with RFI suppression filters.

Ground leakage current exceeds 3.5 mA and is less than 1000 mA.

Transient and steady-state ground leakage currents, which may occur when starting the equipment, should be taken into account when selecting instantaneous residual current circuit breakers (RCCBs) or residual current devices (RCDs).

RCCBs must be selected sensitive to DC unidirectional pulses (Class A) and insensitive to transient current pulses.

Note also that the ground leakage currents of the load will be carried by this RCCB or RCD.



## WARNING

Under typical operation and with all UPS doors closed, only normal safety precautions are necessary. The area around the UPS system should be kept free of puddles of water, excess moisture and debris.

Special safety precautions are required for procedures involving handling, installation and maintenance of the UPS system and the battery. Observe all safety precautions in this manual before handling or installing the UPS system. Observe all precautions in the Operation and Maintenance Manual, before as well as during performance of all maintenance procedures. Observe all battery safety precautions before working on or near the battery.

**This equipment contains several circuits that are energized with high voltage.** Only test equipment designed for troubleshooting should be used. This is particularly true for oscilloscopes. Always check with an AC and DC voltmeter to ensure safety before making contact or using tools. Even when the power is turned Off, dangerously high electric charges may exist within the UPS.

**All power and control wiring should be installed by a qualified electrician.** All power and control wiring must comply with the NEC and applicable local codes.

**ONLY qualified service personnel should perform maintenance on the UPS system.**

When performing maintenance with any part of the equipment under power, service personnel and test equipment should be standing on rubber mats. The service personnel should wear insulating shoes for isolation from direct contact with the floor (earth ground).

Never work alone, even if all power is removed from the equipment. A second person should be standing by to assist and summon help in case an accident should occur.



## CAUTION

This unit complies with the limits for a Class A digital device, pursuant to Part 15 Subpart J of the FCC rules. These limits provide reasonable protection against harmful interference in a commercial environment. This unit generates, uses and radiates radio frequency energy and, if not installed and used in accordance with this instruction manual, may cause harmful interference to radio communications. This unit is not designed for use in a residential area. Operation of this unit in a residential area may cause harmful interference that the user must correct at his own expense.

### Battery Cabinet Precautions

The following warning applies to all battery cabinets supplied with UPS systems. Additional warnings and cautions applicable to battery cabinets may be found in **3.0 - Battery Installation**.



## WARNING

Internal battery strapping must be verified by manufacturer prior to moving a battery cabinet (after initial installation).

- Battery cabinets contain non-spillable batteries.
- Keep units upright.
- Do not stack.
- Do not tilt.

Failure to heed this warning could result in smoke, fire or electric hazard.











Call 1-800-LIEBERT before moving battery cabinets (after initial installation).



---

## GLOSSARY OF SYMBOLS

---

	<b>Risk of electrical shock</b>
	<b>Indicates caution followed by important instructions</b>
	<b>AC input</b>
	<b>AC output</b>
	<b>Requests the user to consult the manual</b>
	<b>Indicates the unit contains a valve-regulated lead acid battery</b>
	<b>Recycle</b>
	<b>DC voltage</b>
	<b>Equipment grounding conductor</b>
	<b>Bonded to ground</b>
	<b>AC voltage</b>

## 1.0 INSTALLATION

The Liebert NX™ UPS is designed primarily for telecommunications and data processing applications. Liebert Corporation neither recommends nor knowingly sells this product for use with life support and other designated “critical” devices.

This section describes the NX’s environmental requirements and mechanical considerations that must be taken into account when planning the positioning and cabling of the UPS equipment.

Because every site is unique, this section presents a guide to general procedures and practices that should be observed by the installing engineer, rather than step-by-step installation instructions.



### WARNING

Do not apply electrical power to the UPS equipment before the arrival of the commissioning engineer.



### WARNING

The UPS equipment should be installed by a qualified engineer in accordance with the information contained in this section.



### WARNING

Special care should be taken when working with the batteries associated with this equipment. When connected together, the nominal battery voltage is 288VDC and is potentially lethal.

- Eye protection should be worn to prevent injury from accidental electrical arcs.
- Remove rings, watches and all metal objects.
- Only use tools with insulated handles.
- Wear rubber gloves.

If a battery leaks electrolyte or is otherwise physically damaged, it must be replaced, stored in a container resistant to sulfuric acid and disposed of in accordance with local regulations.

If electrolyte comes into contact with skin, the affected area should be washed immediately with large amounts of water.



### NOTE

*The NX UPS can be used in TN utility system.*

### 1.1 External Inspections

1. While the UPS system is still on the truck, inspect the equipment and shipping container(s) for any signs of damage or mishandling. Do not attempt to install the system if damage is apparent. If any damage is noted, file a damage claim with the shipping agency within 24 hours and contact Liebert Global Services at 1-800-LIEBERT to inform them of the damage claim and the condition of the equipment.
2. Compare the contents of the shipment with the bill of lading. Report any missing items to the carrier and your local Liebert representative immediately.

### 1.2 Internal Inspections

1. Remove any packaging material, then visually examine the UPS and battery equipment for transit damage, both internally and externally. Report any such damage to the shipper and to Liebert immediately.
2. Check the nameplate inside the cabinet door to verify that the model number and rating correspond to the ones specified. Record the model number and serial number in the front of this installation manual. This information is necessary should service be required.
3. Check for loose connections or unsecured components in the cabinet.
4. Check for shipping damage to internal components.

## 1.2.1 Storing for Delayed Installation

If the equipment will not be installed immediately, it must be stored indoors where the humidity is no higher than 90% and the temperature is no higher than 104°F (40°C). The storage area must protect the NX from excessive moisture (see **6.2 - UPS Environmental**).



### CAUTION

If the UPS must remain disconnected from power for more than six (6) months, the battery must be recharged before use. To charge the batteries, the unit must be connected to utility power and started up—the charger operates only while the NX is operating.



### CAUTION

When batteries are installed in the UPS or are cabinet-mounted adjacent to the UPS unit, the battery—not the UPS—dictates the designed maximum ambient temperature.

## 1.3 Preliminary Checks

### 1.3.1 Identification

The equipment supplied has an identification tag on the back of the main door listing the type and size of the UPS.

## 1.4 UPS Location

### 1.4.1 Positioning the UPS

Choose a location for the UPS that offers:

- Easy connection to inputs, outputs and auxiliary equipment
- Enough space to service the UPS
- Air circulation sufficient to expel heat produced by UPS
- Protection against moisture and excessive humidity
- Protection against dust and other particulate matter
- Compliance with fire prevention regulations and practices
- Operating environment temperature of 74-80°F (23-27°C) for maximum battery efficiency

### 1.4.2 Environmental Considerations

Before installing the NX, verify that the UPS room satisfies the environmental conditions stipulated in **6.2 - UPS Environmental**, paying particular attention to the ambient temperature and air exchange system.

The UPS unit should be installed in a cool, dry, clean-air environment with adequate ventilation to keep the ambient temperature within the specified operating range 32°F to 104°F (0°C to 40°C).

For optimal UPS and battery system performance and service life, maintain the operating temperature within the range of 74-80°F, (23-27°C).

The NX UPS cooled by internal fans. Cooling air enters the unit through the front of the unit and is exhausted out the top. To permit proper air flow and prevent overheating, do NOT block or cover the ventilation openings or blow air down onto the unit. Ventilation clearance above the unit must be a minimum of 24 in. (610mm).

See **Table 9** for details on heat dissipation.

#### Battery Location

Temperature is a major factor in determining battery life and capacity. Battery manufacturers recommend an operating temperature of 77°F (25°C). Ambient temperatures warmer than this reduce battery life; temperatures below this reduces battery capacity. In a typical installation, battery temperature should be maintained between 74°F and 80°F (23-27°C). Batteries should be placed where there are no main heat sources or air inlets to prevent portions of batteries from being either much warmer or much cooler than other parts of the batteries.

### 1.4.3 Special Considerations for 1+N Systems

1. Consider the grounding configuration of your system before finalizing module placement. For optimal ground performance, the NX modules should be close together.
2. For optimal load-sharing performance, the UPS output cables should be approximately the same length, plus or minus 20 percent.
3. Position modules in such a way as to minimize the length of power cables and control wiring between UPS modules and the paralleling cabinet.

## 1.5 Considerations in Moving the NX

Ensure that the UPS weight is within the designated surface weight loading (lb./ft<sup>2</sup> or kg/cm<sup>2</sup>) of any handling equipment. See **Table 9** for weights of various units.

To move the UPS and optional battery cabinets:

- The NX may be rolled on its casters when moving the unit a short distance. For longer distances, move the UPS with a forklift or similar equipment to ease the relocation and to reduce vibration.

The optional battery cabinets should be moved with a forklift or similar equipment.



### WARNING

Ensure that any equipment that will be used to move the NX has sufficient lifting capacity. The NX weight ranges from 850 to 1400 lb. (386 to 635kg). See **Table 9** for details. The UPS presents a tipping hazard. Do not tilt the NX further than 15 degrees from vertical.

The UPS is fitted with casters—take care to prevent movement when unbolting the equipment from its shipping pallet. Ensure adequate personnel and lifting equipment are available when taking the NX off its shipping pallet. Do not tilt the unit more than 15 degrees from center.



### WARNING

The casters are strong enough for movement across even surfaces only. Casters may fail if they are subjected to shock loading, such as being dropped or rolled over holes in the floor or obstructions. Such failure may cause the unit to tip over, injuring personnel and damaging the equipment.

Care must be taken when maneuvering units fitted with batteries. Keep such moves to a minimum. For further information, see **Battery Cabinet Precautions on page 2**.

### Final Position

When the equipment has been finally positioned, ensure that the adjustable stops are set so that the UPS will remain stationary and stable (see **7.0 - Installation Drawings**).

## 1.6 Mechanical Considerations

The NX is constructed with a steel frame and removable panels. Top and side panels are secured to the chassis by screws. The doors may be opened for access to power connections bars, auxiliary terminals blocks and power switches.

The UPS comes with an operator control panel, which provides basic operational status and alarm information. The cabinet houses both the power components and the internal batteries. Cooling is provided by internal fans. The unit sits on four casters. Adjustable stops are provided to prevent the UPS from moving once it has been moved to its final position.

### 1.6.1 Clearances

There are no ventilation grilles on the sides or rear of the UPS. The sides must be accessible during installation. After installation, the unit may be placed with the rear against a wall and optional cabinets on either side.

To enable routine tightening of power terminations within the UPS, make sure there is sufficient clearance in front of the NX to permit free passage of personnel with the door fully opened.

Leave a minimum of 2 ft. (610mm) between the top of the UPS and the ceiling to permit adequate air circulation above the unit. Liebert recommends against using air conditioning or other systems that blow air onto the top of the unit.

### 1.6.2 Floor Installation

The diagrams in **7.0 - Installation Drawings** show the location of holes in the base plate for bolting the equipment to the floor. An optional anchoring kit is available. For information, see your local Liebert representative.

If the equipment is to be placed on a raised floor, it should be mounted on a pedestal that will support the equipment point loading. Refer to the bottom view in **Figure 28** to design this pedestal.

### 1.6.3 Cable Entry

Cables can enter the NX from the top or bottom. Cable entry is made possible by removing a metal plate attached to the UPS.

These plates are designed to allow the personnel to punch holes for fitting and securing the conduit. Once the conduit holes are punched, these plates should be reattached to the UPS.

Connecting cables to the NX may require that the UPS be accessible from the left side to allow personnel to complete the connections and make necessary adjustments. After installation is complete, the NX may be serviced from the front.



#### NOTE

*When installing the UPS, the customer must provide a disconnect with overcurrent protection at the output of the UPS.*

### 10-30kVA UPS

The 10-30kVA NX consists of a single cabinet housing the UPS components and the internal battery string.

Optional battery cabinets are available to provide extended run time. Each cabinet houses additional strings of batteries that operate in parallel with the NX's internal batteries. The cabinets are designed to be bolted to the right side of the UPS (see **Figure 1**). Refer to **3.4 - External Battery Cabinet Installation** for details.

Optional maintenance bypass/transformer cabinets (MBC-T) are available. These cabinets house the components necessary to:

- Provide an external wrap-around maintenance bypass switch for servicing the UPS
- Provide voltage transformation for site or application requirements
- Provide a means for neutral isolation and allow installations for site without a neutral conductor

MBC-T cabinets are designed to be bolted to the left side of the UPS (see **Figure 1**). Refer to **4.5 - Locating the Cabinet**, for further details.

### System Composition

A UPS system can comprise a number of equipment cabinets, depending on the individual system design requirements—e.g., UPS cabinet and External Bypass cabinet. In general, all cabinets used will be the same height and are designed to be positioned side-by-side to form an aesthetically appealing equipment suite.

### 1.6.4 Optional Cabinets

If your NX installation includes a Maintenance Bypass Cabinet, the NX must be positioned to allow the Maintenance Bypass Cabinet to be bolted to **left** side of the NX (see **Figure 1**). Cables from the Maintenance Bypass Cabinet must be brought through the bottom side of the NX for connection.

The Maintenance Bypass Cabinet must be cabled and bolted to the NX **before** the UPS and bypass cabinet are moved into their final position. Connect the input wiring to the Maintenance Bypass Cabinet **ONLY** after the units are connected and positioned.

Battery cabinets may be bolted to either side of the NX, unless used in configurations that include a Maintenance Bypass Cabinet. If used with a Maintenance Bypass Cabinet, battery cabinets must be installed on the right side of the UPS; see **Figure 1** below.

**Figure 1 Cabinet arrangement**

ALL UNITS VIEWED FROM ABOVE

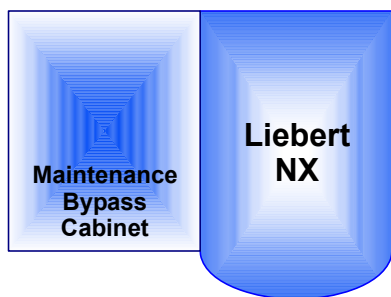

NX connected only to MBC  
(MBC must be on left side of the NX)

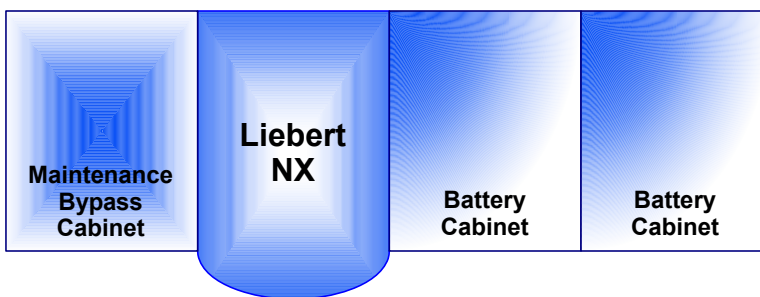

NX connected to Maintenance Bypass Cabinet and Battery Cabinets  
(MBC must be on left side of the NX)  
(Battery Cabinets must be on the right side of the NX in this configuration)

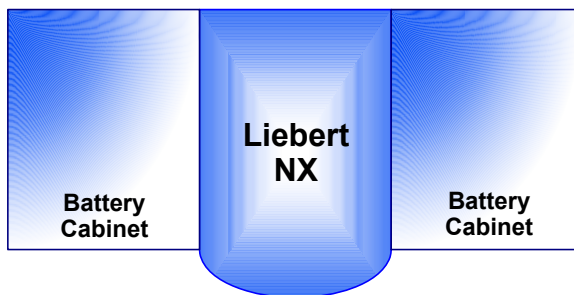

NX connected to Battery Cabinets  
(Battery Cabinets may be on either side of the NX)

## 2.0 ELECTRICAL CONNECTIONS

The UPS requires both power and control cabling once it has been mechanically installed. All control cables must run separate from power cables in metal conduits or metal ducts that are electrically bonded to the metalwork of the cabinets to which they are connected.



### WARNING

Before connecting input power to the NX, ensure that you are aware of the location and operation of the overcurrent protection devices that connect the UPS input/bypass supply to the power distribution panel.

De-energize and lockout or tagout all incoming high- and low-voltage power circuits before installing cables or making any electrical connections.

## 2.1 Power Cabling

### 2.1.1 Cable Rating

The main factors affecting the choice and size of cable are voltage, current (also taking into account overcurrent), room temperature and conditions of installation of the cable.

The power cables of the system must be sized with respect to the following description:

- **UPS input cables** - The UPS input cables must be sized for the maximum input current, including the maximum battery recharge current, given in **Table 10**, with respect to the unit rating and the input AC voltage.
- **UPS bypass and output cables** - The bypass and output cables must be sized for the nominal output current, given in **Table 10**, with respect to the unit rating and the output AC voltage.
- **Battery cables** - Each UPS unit has its own internal batteries factory-wired. If connecting an external battery cabinet, the battery cables must be sized for the battery discharge current at the end-of-discharge voltage, as given in **Table 10**, with respect to the unit rating.



### NOTE

*Table 10 gives nominal currents for determining the size of UPS power cables. Other important factors to consider include cable route length and coordination with protective devices.*

The power cables can be sized to suit the UPS unit rating according to **Table 10**.

### Lug Size and Torque Requirements

Refer to **Table 27** for lug size and torque requirements.

### 2.1.2 UPS Input Configuration

**Figure 2** illustrates the NX in a split bypass (dual-input) configuration. In this configuration the Static Bypass and the Maintenance Bypass lines are supplied from a separate feed from the Main input. Both sources must be protected externally with properly sized protective devices. By default, the unit ships with internal links installed between the Bypass input and Main input (Single Input configuration). To wire the unit as a dual input UPS, remove the links and wire the bypass to the input bus bars, then wire the Main input directly to CB1 (see **Figure 3**).

**Figure 2** Single module block diagram—dual input configuration

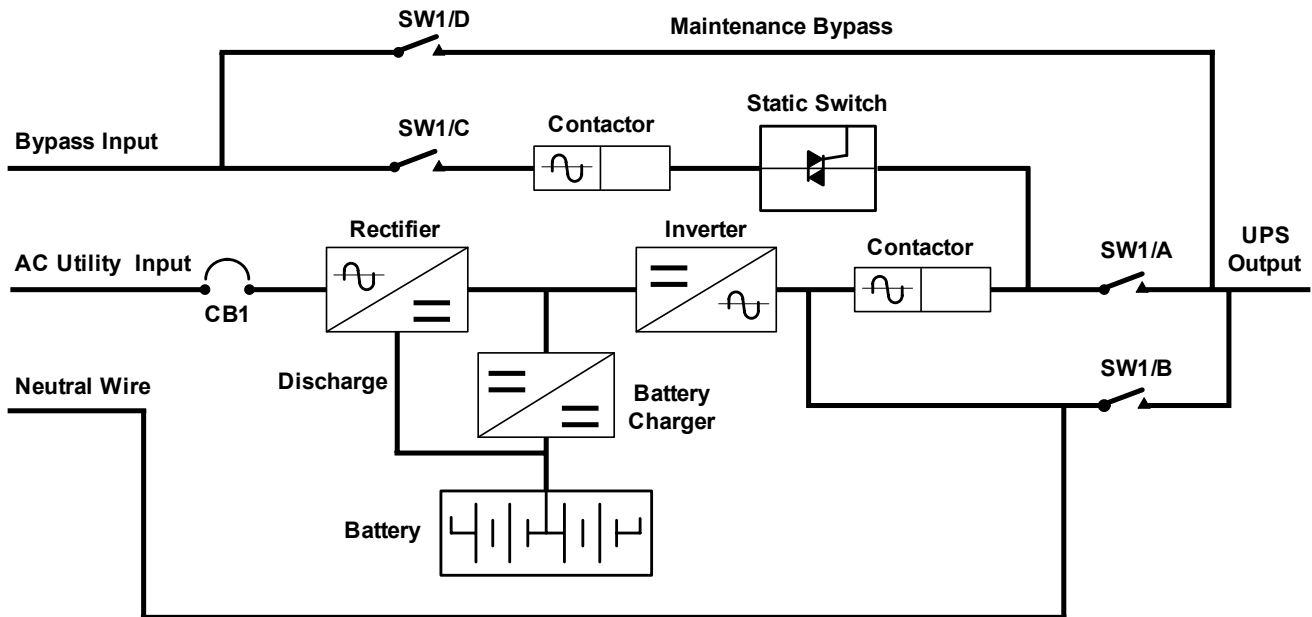

### 2.1.3 Cabling Guidelines

The following are guidelines only and are superseded by local regulations and codes of practice where applicable.

1. Take special care when determining the size of the neutral cable, as current circulating on the neutral cable may be greater than nominal current in the case of non-linear loads. Refer to the values in **6.4 - UPS Electrical Characteristics**.
2. The ground conductor should be sized according to such factors as the fault rating, cable lengths and type of protection. The ground cable connecting the UPS to the main ground system must follow the most direct route possible. Control wiring and power wiring must be run in separate conduit. Output and input cables must be run in separate conduit.
3. Consider using paralleled smaller cables for heavy currents—this can ease installation.
4. When sizing battery cables, a maximum voltage drop of 4VDC is permissible at the current ratings in **Table 10**. For terminal connection sizing, see **Table 10**.
5. In most installations, especially parallel multi-module systems, the load equipment is connected to a distribution network of individually protected busbars fed by the UPS output, rather than connected directly to the UPS itself. When this is the case, the UPS output cables can be rated to suit the individual distribution network demands rather than being fully load-rated.



#### NOTE

*If more load is added to the distribution panel, the unit's cabling must be resized.*

6. When laying power cables, do not form coils; this will help avoid increasing formation of electromagnetic interference.



#### NOTE

*Left-side access may be required when making power connections. Cable connections should be made before a cabinet is attached to the left side of the NX or before the UPS is placed where another obstruction, such as a wall, is against the NX's the left side.*



### 2.1.4 Cable Connections

The rectifier input, bypass and output are easily accessible from the left side of the unit for installation. All require lug type terminations. They are connected to busbars on the left side of the NX and below the switch, as shown in **Figure 3**. These busbars are accessible when the left side panel is removed. Busbars to connect external batteries are accessible from the front of the UPS.



**NOTE**

*External battery connection access requires removal of a protective panel on the lower front of the UPS to the left of the bottom two battery shelves.*

**Figure 3 Input busbars**

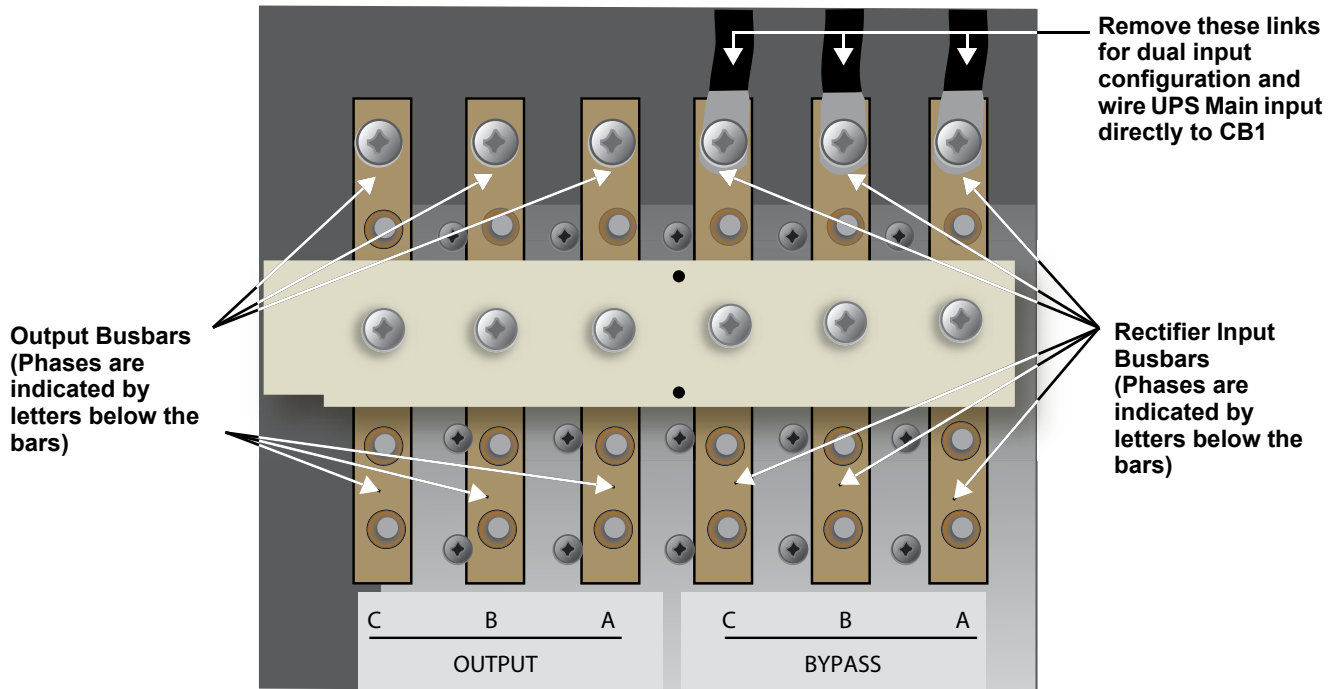

The internal batteries are connected with Anderson connectors inside the battery compartment. The batteries are connected to fuses to protect the NX and connected equipment (see **Figure 4**).

**Figure 4 Battery fuses and connections**

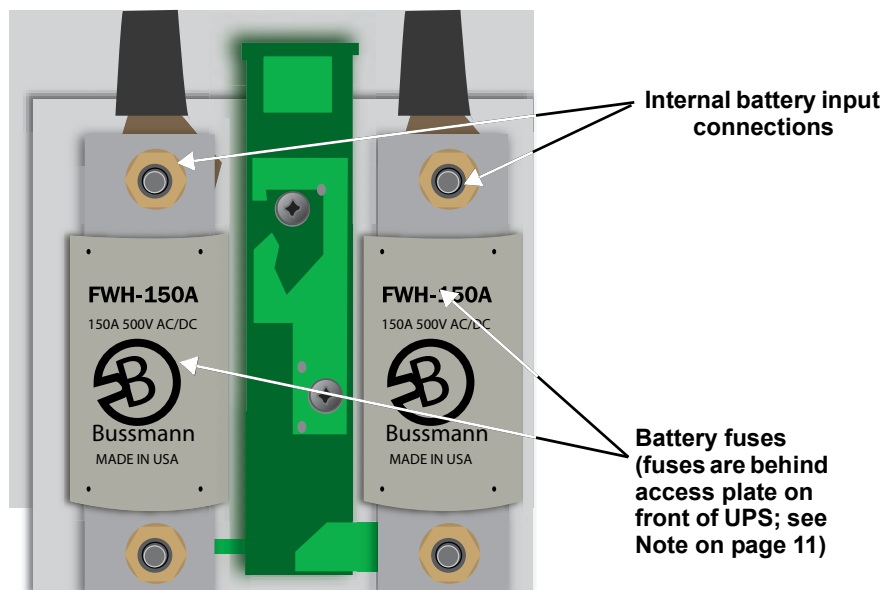

### 2.1.5 Safety Ground

The safety ground busbar is located below the neutral input and output busbars as shown in **Figure 5** below. The safety ground cable must be connected to the ground busbar and bonded to each cabinet in the system.

All cabinets and cable conduit should be grounded in accordance with local regulations.



## WARNING

Failure to follow proper grounding procedures can result in electric shock hazard to personnel or the risk of fire, should a ground fault occur.



### NOTE

Proper grounding significantly reduces problems in systems caused by electromagnetic interference.



### NOTE

The ground and neutral busbars are easily accessible when the left protective cover plate is removed. Cable connections should be made before a cabinet is attached to the left side of the NX or before the UPS is placed where another obstruction, such as a wall, is against the NX's the left side.

**Figure 5** Ground and neutral busbar connections

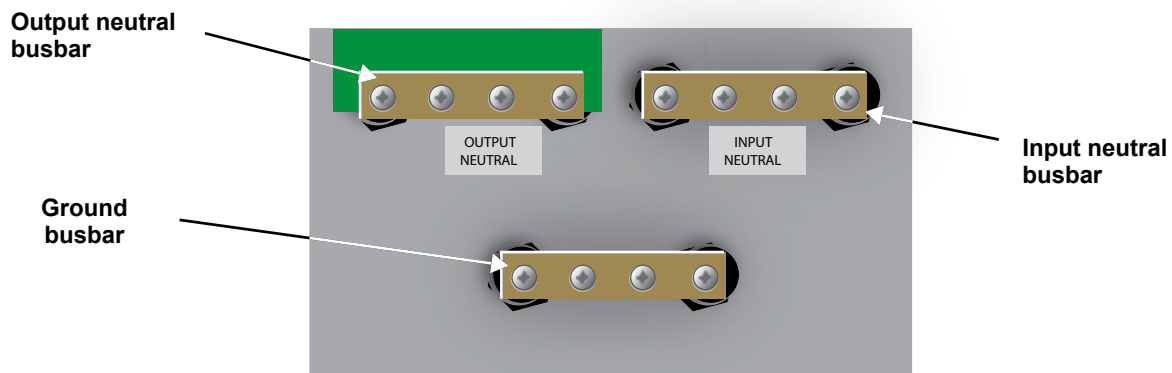

### 2.1.6 Protective Devices

For safety, it is necessary to install circuit breakers in the input AC supply and external battery battery cabinets, external to the UPS system. Given that every installation has its own characteristics, this section provides guidelines for qualified installation engineers with knowledge of operating practices, regulatory standards and the equipment to be installed.

#### UPS Rectifier and Bypass Input Supply

- **Protection from excessive overcurrents and short circuits in power supply input**

External overcurrent protection for the AC output circuit is to be provided. See **6.4 - UPS Electrical Characteristics** and **Table 12** for overload capacity.

High-speed fuses and SCRs are used for internal battery circuit overcurrent protection. When an external battery supply is used, overcurrent protection for the battery circuit is to be provided by the customer.

- **Dual Input**

When wiring the UPS with dual inputs, the Rectifier input and the Bypass input must be protected separately. Size the breakers according to the input currents shown in **Table 10**.

#### System Output

When using an external distribution panel for load distribution, the output neutral and input neutral must be separated at the input to the UPS.

## 2.1.7 Cabling Procedure



### CAUTION

The operations described in this section must be performed by authorized electricians or qualified technical personnel. If you have any difficulties, contact your local Liebert representative or Liebert Global Services.



### NOTE

*Hydraulic pressure pliers, combinative tools and piston ring pliers should be used to connect AC wiring.*

Once the equipment has been positioned and secured for operation, and the battery and ground collars have been connected (see **2.1.4 - Cable Connections**), connect the power cables as described below. (Study the reference drawing in **7.0 - Installation Drawings**.)

1. Verify that all incoming high and low voltage power circuits are de-energized and locked out or tagged out before installing cables or making any electrical connections.
2. Remove the left side panel to gain easier access to the connections busbars.
3. Connect the safety ground and any easier bonding ground bus cables to the copper ground busbar located on the bottom of the equipment below the power connections. All cabinets in the UPS system must be connected to the user's ground connection.



### NOTE

*The grounding and neutral bonding arrangement must comply with the National Electrical Code and all applicable local codes.*

4. Identify and make power connections with incoming cables according to **Steps 5** through **11**.

### Common Input Connections

5. For common bypass and rectifier inputs, connect the AC input supply cables between the power distribution panel and the UPS input busbars (A-B-C terminals) and tighten the connections to 44 lb-in. (5 N-m) using the M6 bolt provided.
6. The input neutral cable must be connected to the input neutral busbar (N). See **Figure 5**.

### Dual Input Connections

7. For bypass connect the AC input supply cables between the power distribution panel and the UPS input busbars (A-B-C terminals) and tighten the connections to 44 lb-in. (5 N-m) using the M6 bolt provided.
8. For Rectifier Input connect AC input supply cables between the power distribution panel and the UPS input circuit breaker (A-B-C terminals)
9. The bypass and rectifier input neutral cables must be connected to the input neutral busbar (N). See **Figure 5**.



### NOTE

*Both the rectifier and bypass feeds **MUST** come from the same utility source, except if the UPS system includes either a configuration F or P external maintenance bypass cabinet.*

### Output System Connections—Ensure Correct Phase Rotation

10. Connect the system output cables between the UPS output busbars (A-B-C N terminals) and the critical load and tighten the connections to 44 lb-in. (5 N-m) (M6 bolt).



### WARNING

If the load equipment will not be ready to accept power on the arrival of the commissioning engineer, then ensure that the system output cables are safely isolated.

## Internal UPS Battery Connections

The UPS internal batteries will be connected at the factory, EXCEPT the Anderson connections between the shelves and to the fuses.



### WARNING

The DC bus is live when this internal battery connection is made. This connection is to be performed ONLY by Liebert Global Services at startup.

**Observe the battery cable polarity.** Be sure that the battery connector is made with the correct polarity.

11. Refit all protective covers removed for cable installation

## 2.2 Control Cables

### 2.2.1 Monitor Board Features

Based on your site's specific needs, the UPS may require auxiliary connections to manage the battery system (external battery circuit breaker, battery temperature sensor), communicate with a personal computer or provide alarm signaling to external devices or for Remote Emergency Power Off (REPO). The monitor board, arranged for this purpose, is located on the rear of the operator access door. The main features are:

- Input and Output dry contacts signal (one pair of contacts of relay)
- Emergency Power Off control (EPO)
- Environmental parameter input interface
- User communication (for data setting and user background monitor)
- Intellislot™ interface
- Modem interface
- Temperature detect interface

**Figure 6** shows the relationship and connection between the monitoring (U2) board and other boards in the UPS.

**Figure 6** Monitor board U2

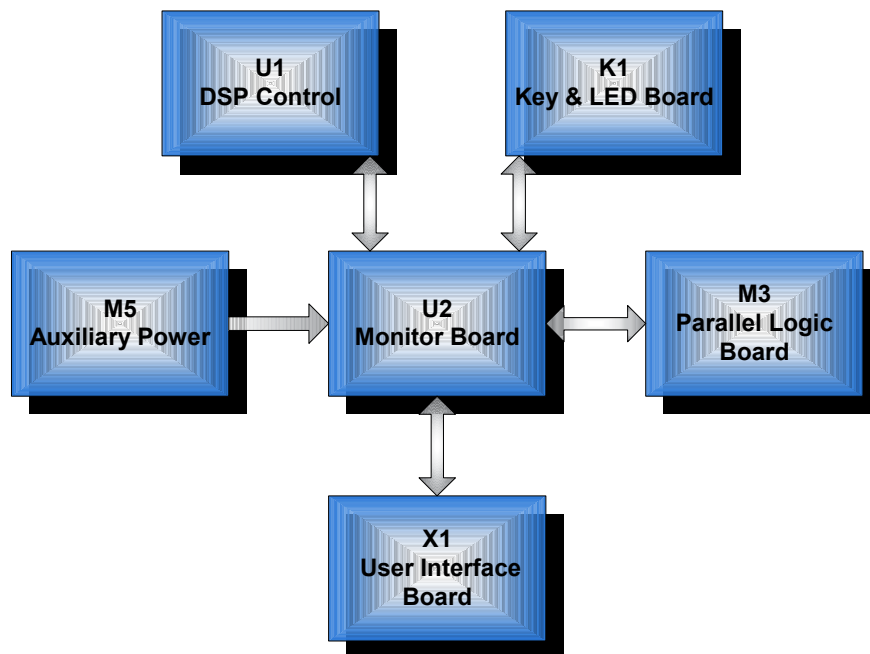
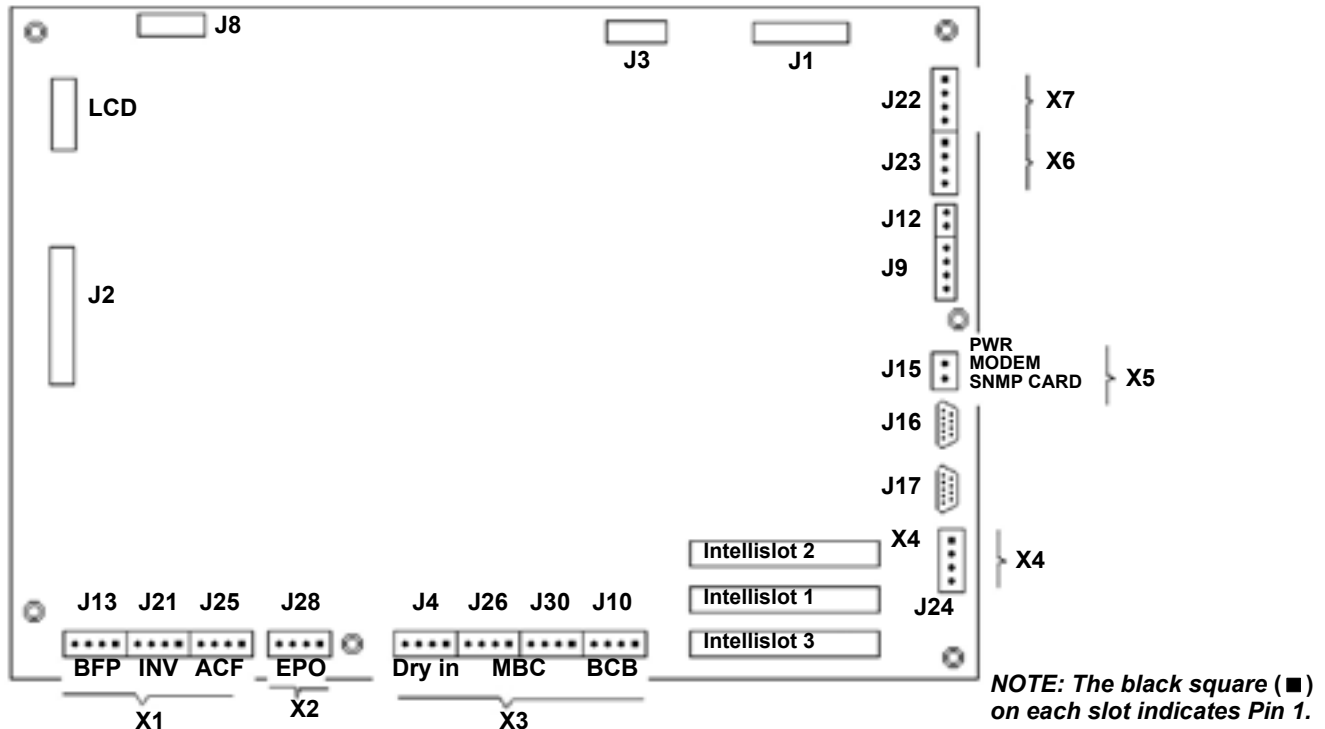

Figure 7 Auxiliary terminal block detail (Monitoring Board)



### 2.3 Dry Contacts

The UPS provides input dry contacts and output dry contacts.

#### 2.3.1 Input Dry Contacts

There are several input dry contacts at the X3 slot.

Figure 8 Input dry contacts

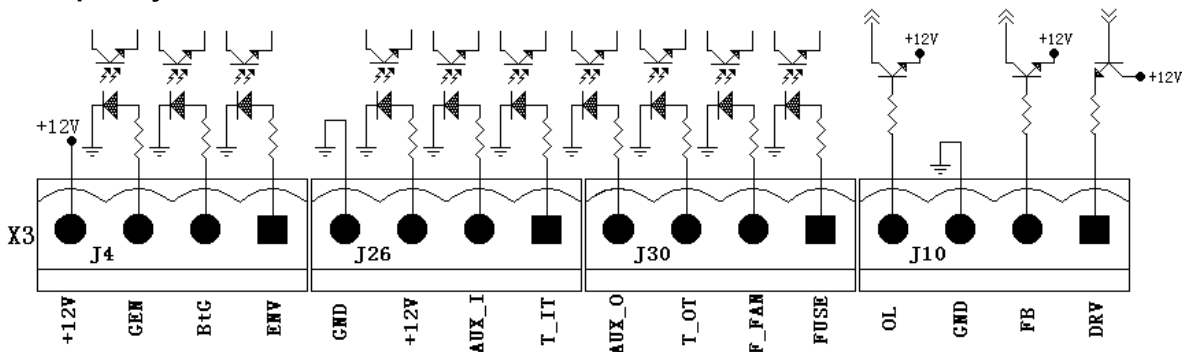

NOTE: The black square (■) on each slot indicates Pin 1.

Table 1 Input dry contacts at X3

Position	Name	Description
J4.1	ENV <sup>3</sup>	Battery Room Alarm (N.C.)
J4.2	BtG	Battery Ground Fault Detection (N.C.)
J4.3	GEN <sup>1,2</sup>	Generator Join Detection (N.O.)
J4.4	+12V	+12V Power

1 - Must be configured by configuration software before becoming active.

2 - When activated, the charger current can be limited, via software, to a percentage of the full charger current (0-100%).

3 - Activating this feature turns the battery charger off.

### 2.3.2 Maintenance Bypass Cabinet Interface

J26 and J30 are the MBC interface.

**Table 2 Maintenance bypass cabinet interface**

Position	Name	Description
J26.1	T_IT <sup>1</sup>	Input transformer over temperature (N.C.)
J26.2	AUX_I	Reserved
J26.3	+12V	+12V Power
J26.4	GND	Power Ground
J30.1	FUSE	Reserved
J30.2	F_FAN	Fan Fail Alarm (N.C.)
J30.3	T_OT <sup>1</sup>	Output Transformer Overtemperature (N.C.)
J30.4	AUX_O	Reserved

1 - Must be configured by software before becoming active



**NOTE**

All auxiliary cables of terminal must be double-insulated. Wire should be 20-16AWG stranded for maximum runs between 82 and 164 feet (25-50m), respectively.

### 2.3.3 BCB Box Interface

J10 is the BCB box interface.

**Table 3 BCB box interface**

Position	Name	Description
J10.1	DRV	BCB Driver Signal - Reserved
J10.2	FB	BCB Contact State
J10.3	GND	Power Ground
J10.4	OL	BCB On-Line - Input - This pin will become active when BCB interface is connected. (N.O.)



**NOTE**

All auxiliary cables of terminal must be double-insulated. Wire should be 20-16AWG stranded for maximum runs between 82 and 164 feet (25-50m), respectively.



**NOTE**

If BCB interface is connected, a jumper needs to be added between Pin 3 and Pin 4.

**Figure 9 Jumper connection for BCB interface**

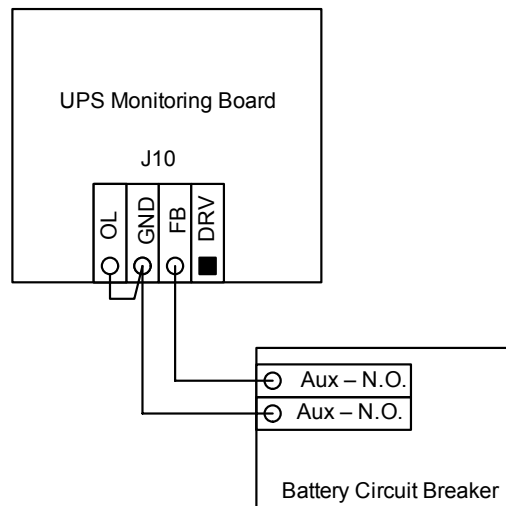

### 2.3.4 Output Dry Contacts

There are three output dry contact relays at the X1 slot (see **Figure 10** and **Table 4**).

**Figure 10** Output dry contacts and EPO wiring for firmware before M170

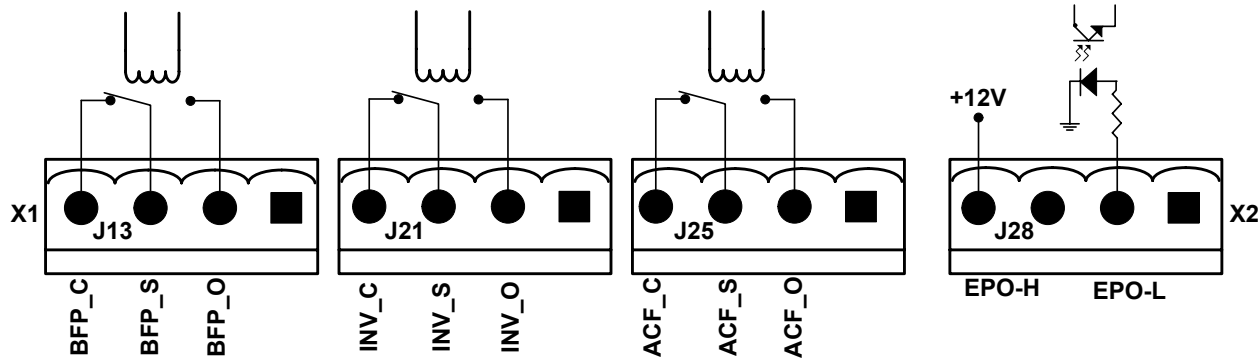

**Table 4** Output dry contact relays

Position	Name	Description
J13.2	BFP_O	Bypass feedback protection relay. Normally open. Closed when bypass SCR is shorted.
J13.3	BFP_S	Bypass feedback protection relay center
J13.4	BFP_C	Bypass feedback protection relay. Normally closed. Open when bypass SCR is shorted.
J21.2	INV_O	Inverter mode relay. Normally open. Closed when UPS is in inverter mode.
J21.3	INV_S	Inverter mode relay center
J21.4	INV_C	Inverter mode relay. Normally closed. Open when UPS is in inverter mode.
J25.2	ACF_O	Main input fault relay. Normally open. Closed when main input is in fault.
J25.3	ACF_S	Main input fault relay center
J25.4	ACF_C	Main input fault relay. Normally closed. Open when main input is in fault.



#### NOTE

All auxiliary cables of terminal must be double-insulated. Wire should be 20-16AWG stranded for maximum runs between 82 and 164 feet (25-50m), respectively.

### 2.3.5 EPO Input—Optional

#### Firmware Before M200

The UPS has an Emergency Power Off (EPO) function that operates by a button on the control panel or by a remote contact provided by the user. The EPO button is under a hinged, clear plastic shield.

The X2 slot, shown in **Figure 10**, is the remote EPO input interface. It is active when shorted from EPO-L to EPO-H.

If an external Emergency Stop facility is required, it is connected terminals EPO-L to EPO-H of the auxiliary terminal block (X2). It also is connected to the Normally Open remote stop switch between these two terminals using shielded cable (see **Figure 10** and **Table 5**). If this function is not used, terminals EPO-L to EPO-H must be opened.

**Table 5** EPO input contact relays

Position	Name	Description
J28.2	EPO_L	Emergency Power Off Low
J28.4	EPO_H	Emergency Power Off High



#### NOTE

The Emergency Stop action within the UPS shuts down the rectifier, inverter and static bypass. It does not internally disconnect the input power supply.

To disconnect ALL power to the UPS, open the upstream feeder breaker(s) when the remote EPO is activated.

### Firmware M200 or Later

The UPS has an Emergency Power Off (EPO) function operated by a button on the control panel or by a remote contact provided by the user. The EPO button is under a hinged, clear plastic shield.

The X2 slot, shown in **Figure 11**, is the remote EPO input interface. The EPO has a NO/NC contact point becomes active when shorting terminals X2: 3 and 4 or open terminal connection X2: 2 and 1.

If an external Emergency Stop facility is required, it is connected terminals X2: 1&2 or X2: 3 and 4 of the auxiliary terminal block (X2). It also is connected to the Normally Open or Normally Closed remote stop switch between these two terminals using shielded cable (see **Figure 11** and **Table 6**). If this function is not used, terminals X2: 3 and 4 must be opened and X2: 1 and 2 must be closed.

**Figure 11 EPO wiring for firmware M200 or later**

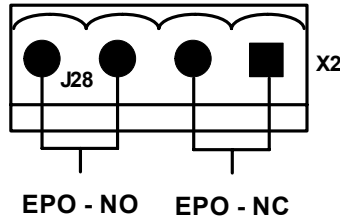

**Table 6 EPO input contact relays**

Position	Name	Description
J28.1	EPO_NC	EPO Activated when opened to J28.2
J28.2	EPO_NC	EPO Activated when opened to J28.1
J28.3	EPO_NO	EPO Activated when shorted to J28.4
J28.4	EPO_NO	EPO Activated when shorted to J28.3



**NOTE**

*The Emergency Stop action within the UPS shuts down the rectifier, inverter and static bypass. It does not internally disconnect the input power supply. To disconnect ALL power to the UPS, open the upstream feeder breaker(s) when the remote EPO is activated.*



**NOTE**

*Normally Closed EPO – X2: 1,2, these terminals are supplied factory-linked on the monitor board and must remain installed if using NC contacts.*



**NOTE**

*All auxiliary cables of terminal must be double-insulated. Wire should be 20-16AWG stranded for maximum runs between 82 and 164 feet (25-50m), respectively.*



## 3.0 BATTERY INSTALLATION

### 3.1 Introduction

Liebert recommends that the batteries in external cabinets match the internal batteries in the NX in manufacturer and type.

If using multiple sets of batteries connected in parallel to provide the required battery backup run times, fit each set with an isolating device to permit working on one of the battery sets while leaving the others in service and providing backup protection.

When replacing batteries, replace with the same manufacturer and type, or equivalent. See your Liebert representative for a list approve batteries.

**NOTE**

*The NX, as shipped, has 24 12-volt batteries installed internally in each unit.*

### 3.2 Safety

Special care should be taken when working with the batteries associated with the NX system equipment. When all batteries are connected together, the battery terminal voltage may exceed 324V and is **POTENTIALLY LETHAL**.

**WARNING**

The NX's internal batteries are connected and energized even if the UPS is turned Off. To minimize the risk of injury, a qualified service person should disconnect internal batteries before any maintenance is performed on the unit.

The center of the battery is connected to the neutral of the UPS and is grounded.

A battery can present a risk of electrical shock and high short circuit current. The following precautions should be observed when working on batteries:

- Remove watches, rings and other metal objects.
- Use tools with insulated handles.
- Wear rubber gloves and boots.
- Do not lay tools or metal parts on top of batteries.
- Disconnect charging source prior to connecting or disconnecting battery terminals.

### 3.3 UPS Batteries

The NX's internal batteries are fully charged before the unit is shipped. During storage and transportation, some charge is lost. All batteries should be recharged before use. The battery charger works only when the NX is connected to input power and turned On.

**NOTE**

*Full safety instructions concerning the use and maintenance of UPS batteries are provided in the appropriate battery manufacturer's manuals, available on the manufacturer's Web site.*

*The battery safety information contained in this section relates to key considerations that must be taken into account during the installation design process and might affect the design outcome, depending on your installation.*

## 3.4 External Battery Cabinet Installation

### 3.4.1 Matching Battery Cabinets

Two sizes of optional battery cabinets are available. Refer to **Figures 13** and **14**. The same model battery cabinet may be installed in parallel in multiple cabinet strings for additional capacity. Battery run time depends on the cabinet model, the number of cabinets and the load on the UPS.

**Handling**—The battery cabinet has casters to facilitate movement over short distances. The bottoms of the battery cabinets are reinforced to permit movement by forklift over longer distances.

**Inspection**—Remove all panels and visually inspect the batteries, bus connections, and cabinet for any damage. Exercise caution; voltage is present within the battery cabinet even before installation. If there are signs of damage, do not proceed. Call Liebert Global Services at 1-800-542-2378.

**Storage**—The batteries can be stored for up to six months without appreciable deterioration. If planning to store a battery cabinet for longer than six months or at temperatures higher than 77°F (25°C), contact Liebert Global Services for recommended precautions.

The following notes, in conjunction with the diagrams (**Figure 13** through **12**), illustrate the broad principles to be followed when fitting and connecting the majority of battery cabinet installations.



### CAUTION

Any battery system should be installed by qualified personnel.

When installing an external battery cabinet that is NOT a Liebert NX battery cabinet, the customer must provide overcurrent protection. See **Table 10** for sizing of protection devices.



### NOTE

*When using an external battery supply that is not provided with the UPS, please make reference to the battery manufacturer's installation manual for battery installation and maintenance instructions, available on the manufacturer's Web site. When replacing batteries, Liebert recommends that the batteries in external cabinets be the same type used internally in the NX. See **Table 11** for a list of batteries that are approved for use with this product.*

### 3.4.2 Connecting the Batteries

If the NX battery cabinets are installed on a raised floor, the battery power cables and circuit breaker control cables may be routed to the UPS cabinet via the floor of the cabinet (bottom entry).

If the NX battery cabinets are installed adjacent to one another on a solid floor, these cables may be passed between the cabinets through lifting slots in the lower sides of the cabinets.

Intertray connections must be made before the battery cabinet may be used.

**Figure 12 Battery cabinet—details**

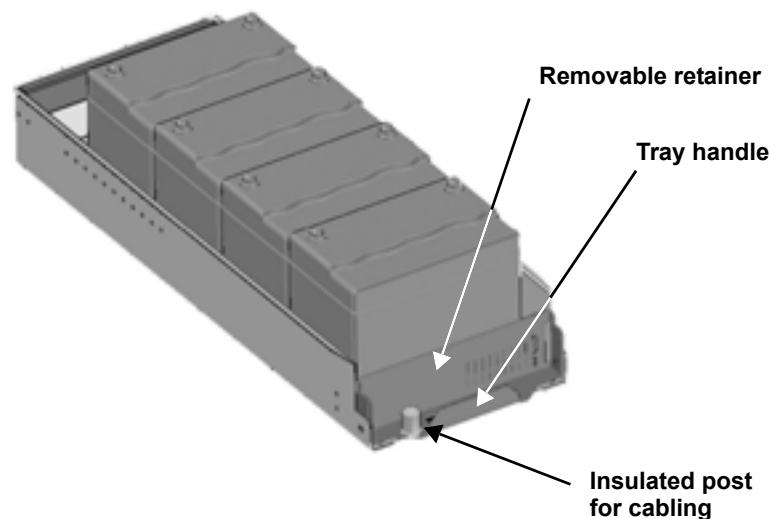

Figure 13 Narrow battery cabinet, 27 in. (690mm) - rear view

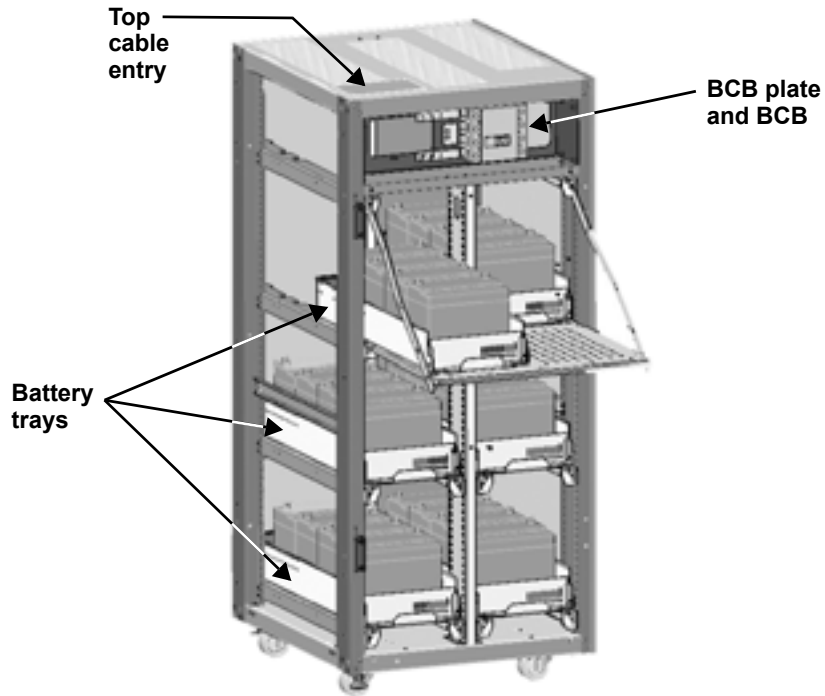
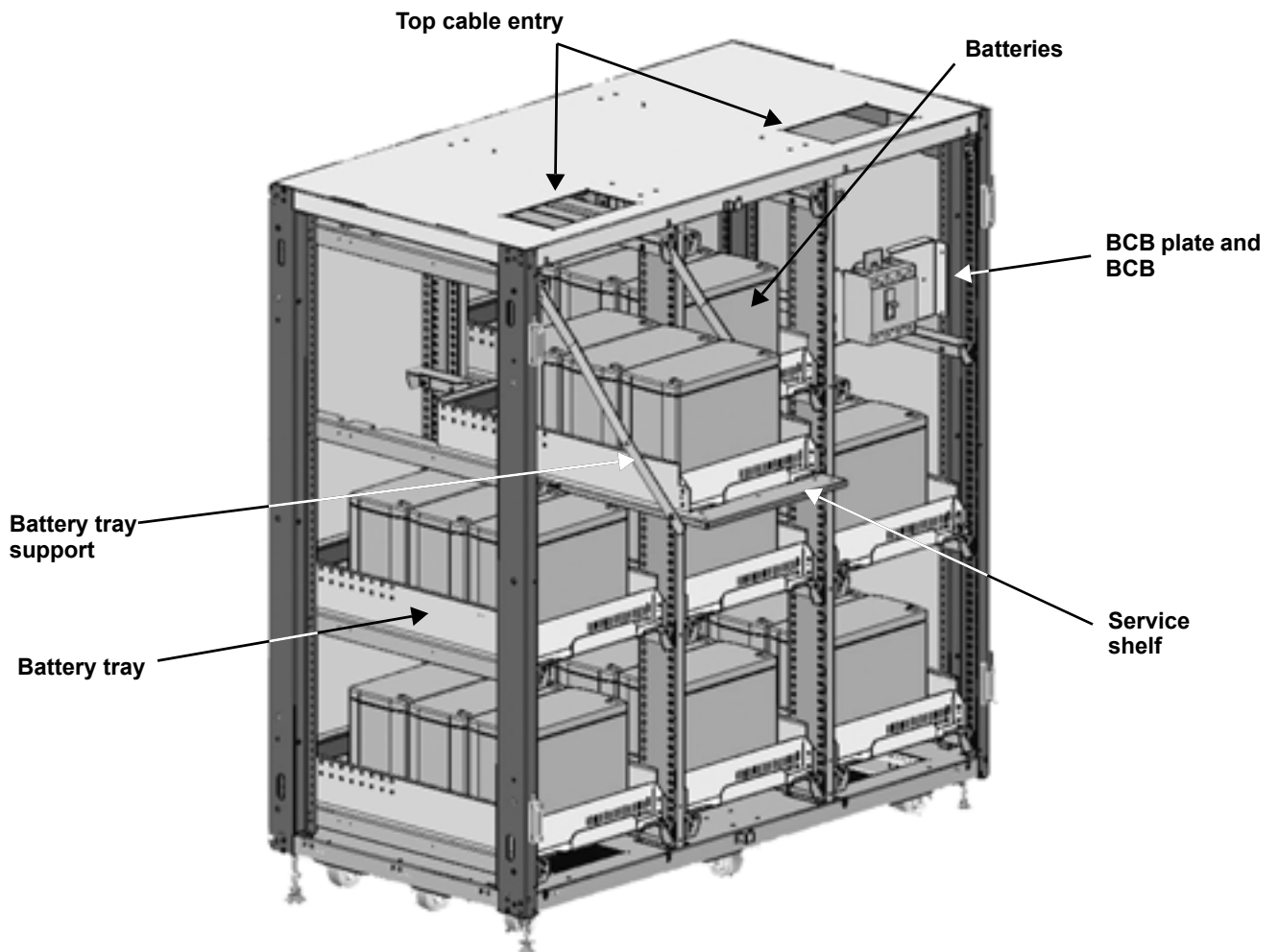

Figure 14 Wide battery cabinet, 57 in. (1488mm) - front view



### 3.4.3 Installation Considerations

**Position**—Liebert battery cabinets come in versions specific to either the left or right side of the UPS. Control wires and power cables are cut to different lengths for the different versions. If the system includes a matching maintenance bypass cabinet (MBC), the MBC should be mounted to the left of the UPS (nearest the busbars) and the battery cabinet(s) should be installed to the right of the UPS. Otherwise, left-side placement of the battery cabinet is preferable.

The battery cabinet(s) are designed to be located conveniently next to each UPS module, and are also available in stand-alone configurations with painted side panels. The front access design eliminates side and rear service clearance requirements. Refer to **Table 33** for battery cabinet dimensions and weights.

**Bolt-On Cabinets**—Matching battery cabinets are designed to bolt onto the side of the UPS module cabinet. Use bolts that ship with each unit to connect cabinet frames at posts, two places in the front and two places in the rear.

**Service Clearance**—Allow front access to the battery cabinet at all times for maintenance and servicing. Electrical codes require that the battery cabinet be installed with no less than 3 feet (1m) of clearance at the front of the cabinet when operating. Side and rear panels do not require service clearance.

**Cables**—Cables may be run between the cabinets through cutouts in the top of the cabinet, eliminating the need for external conduit runs. Route cables before moving cabinets into final position for bolting together. No top or bottom entry cables are required, except for remotely located cabinets which require conduits. Refer to **Figure 15**.

**Software**—To allow the UPS to accurately display the battery run time, the number of battery cabinets must be noted when performing initial startup and setup using the configuration software. This is to be performed by the Liebert Global Services customer engineer when commissioning the unit.

**Casters and Adjustable Stops**—The adjustable stops are not designed to bear the full weight of the cabinet. Lower the stops until they are finger-tight in contact with the floor. Then tighten a small amount with a wrench (less than two turns) to give a good friction fit. When mounting the battery cabinet on seismic stands, ensure that the casters are bearing the weight of the cabinet.

**Battery Support Tray**—Be sure to connect the battery tray support to the front of the cabinet before sliding a battery tray out for connection or service. Without the support, the battery tray may fall out of the cabinet. See **Figure 16** for details.

Figure 15 Internal cable wiring from battery cabinet to Liebert NX

Power cables from output power switch

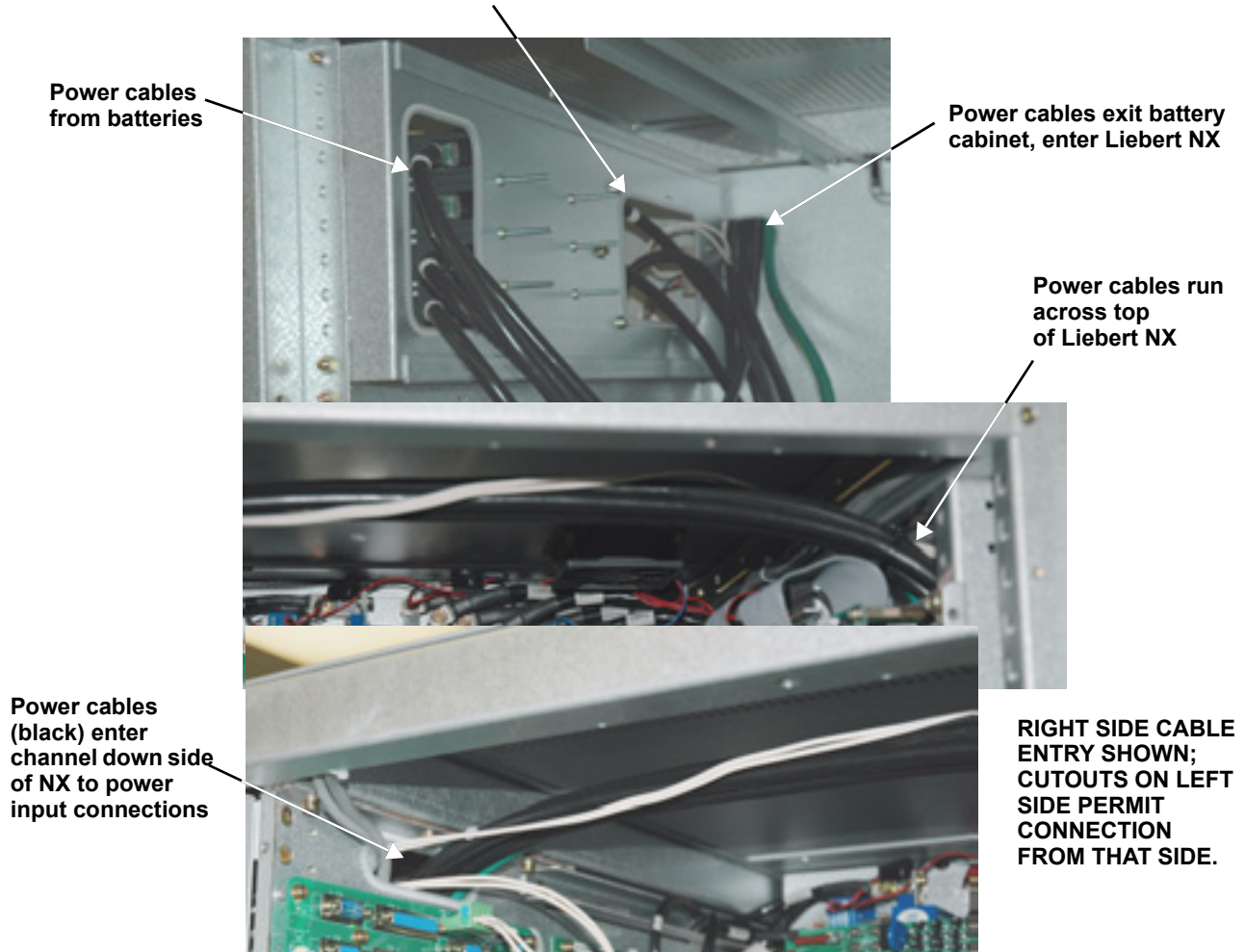
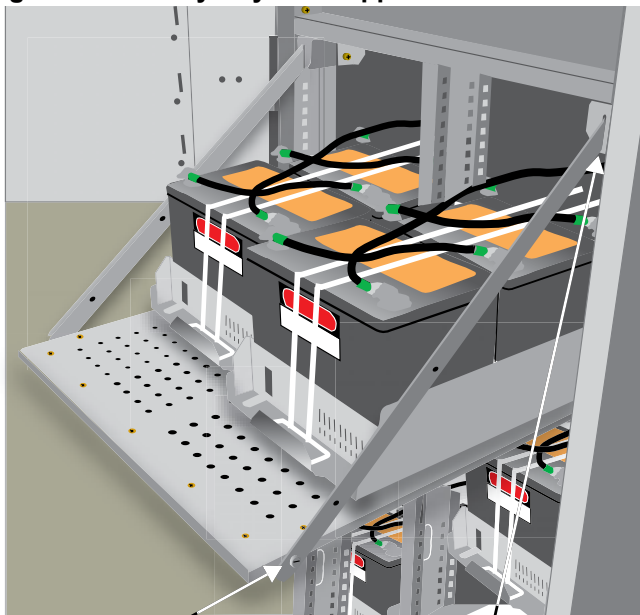

Figure 16 Battery tray and supports



Slot in support secured by screw-in connector at corner of battery tray ...

... and notched end of support slips into slot at top corner of battery compartment

Battery tray supports attach to interior surface of NX front door (note notched ends of supports)

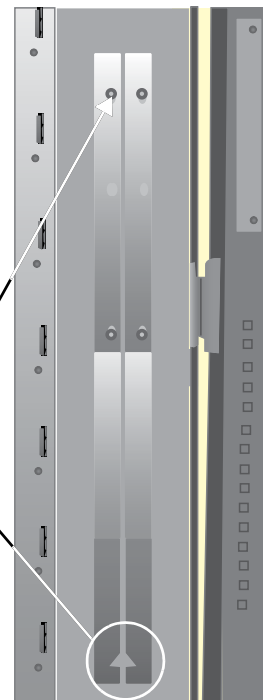

### 3.4.4 Connecting the Battery Cabinet to the UPS

After the battery cabinet equipment has been positioned and secured for operation and the batteries have been connected, connect the power cables as described below. (See **Figure 34**.)

1. Verify that all incoming high and low voltage power circuits are de-energized and locked out or tagged out before installing cables or making any electrical connections.
2. Remove the UPS left side panel to gain access to the equipment ground busbar.
3. Remove the external battery terminal block plate on the lower left side of the UPS behind the front door.
4. Remove the battery cabinet front panel to gain access to the connection bars.
5. Connect the safety ground and any necessary bonding ground cables to the copper ground busbar. (example: UPS located on the bottom of the equipment below the power connections).

All cabinets in the UPS system must be connected to the user's ground connection.



#### NOTE

*The grounding and neutral bonding arrangement must be in accordance with the National Electrical Code and all applicable local codes.*

6. Connect the system battery cables from the UPS battery terminals (+ N -) to battery cabinet BCB (+ N -) as shown in **Figure 34**. Be sure that the battery connections are made with the right polarity, and tighten the connections to 44 lb-in. (5 N-m) (M6 Bolt). Do not close the battery circuit breaker before the equipment has been commissioned.
7. Connect supplied auxiliary control cable to pins J10.2 and J10.3 on the U2 monitoring board (see **2.3 - Dry Contacts**). Add a jumper wire between J10.3 and J10.4.

### 3.5 Non-Standard Batteries

When batteries other than a matching battery cabinet are used, a remote battery disconnect switch with overcurrent protection is required per the National Electrical Code. Contact your local Liebert sales representative about this option.

Install battery racks, cabinets and batteries in accordance with the manufacturer's instructions.

Verify that the battery area has adequate ventilation and battery operating temperature complies with the manufacturer's specifications and with all applicable national and local codes.

If you have any questions concerning batteries, battery racks or accessories, contact Liebert Global Services at 1-800-543-2378.

## 4.0 MAINTENANCE BYPASS CABINET

The Maintenance Bypass Cabinet is designed to operate in UPS mode, bypass mode and maintenance mode. The mode is selected using the Bypass Switch.

**Figure 17 Single UPS with external Maintenance Bypass Cabinet—typical configuration**

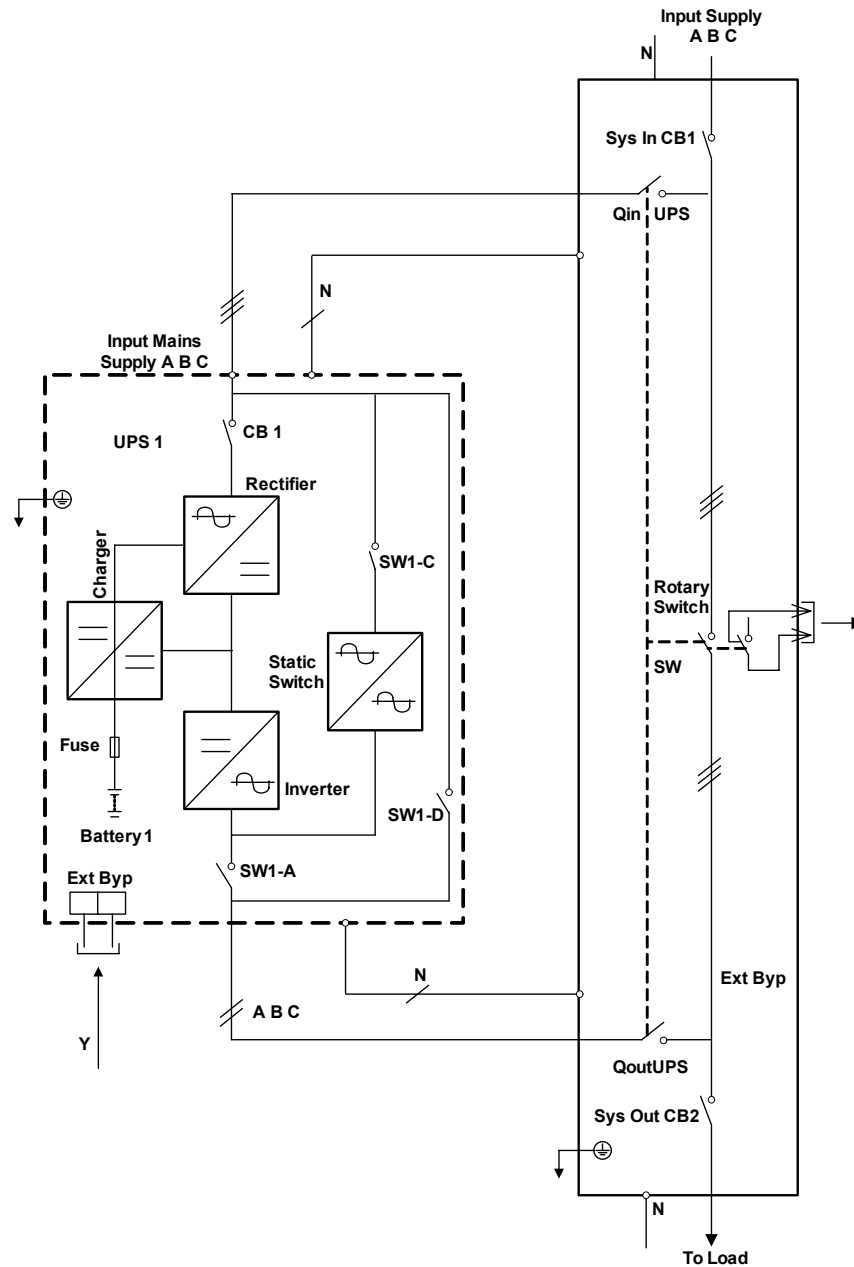

### 4.1 Bypass Switch

The Bypass Switch allows easy and rapid transfer of connected loads between the UPS and Bypass source.

### 4.2 Normal (UPS) Mode

While the Maintenance Bypass Cabinet rotary switch is in the NORMAL position, the UPS is supplying the connected load with continuous, high-quality AC power. In this mode of operation, the load is protected by the UPS.

### 4.3 Bypass Mode

When the Maintenance Bypass Cabinet is in the Bypass mode, it provides an alternate path for power to the connected equipment. Should the UPS need to be taken out of service for limited maintenance or repair, manual activation of the bypass will cause an immediate transfer of the equipment from the UPS inverter to the bypass source. In this mode, power will still be supplied to the UPS; however, the load is NOT protected by the UPS.

### 4.4 Maintenance Mode

When the maintenance bypass cabinet is in the Maintenance mode, it provides an alternate path for power to the connected equipment. Should the UPS need to be taken out of service for limited maintenance or repair. In this mode of operation, no power is supplied to the UPS and the load is NOT protected by the UPS.

### 4.5 Locating the Cabinet

This Maintenance Bypass Cabinet may be mounted to the left of the UPS or installed as a stand-alone unit. In either case, ensure that the unit is in a well-ventilated area and that there is clearance for access to the switches and cable connections as required by national and local codes.

### 4.6 Cable Installation

#### 4.6.1 Wiring Preparation

Be sure that the unit is not connected to any AC utility power source or UPS before installing any wiring to this unit. This Maintenance Bypass Cabinet should be installed by a qualified / certified electrician.



## WARNING

Please read this section thoroughly before attempting to install wiring to this unit.

#### Removing the Cover Plates

Plates cover the input and output terminals on the front of the Maintenance Bypass Cabinet (see **Figure 18**). Remove these and keep the screws and plates for reinstallation.

**Figure 18 Maintenance Bypass Cabinet—access plate removed**

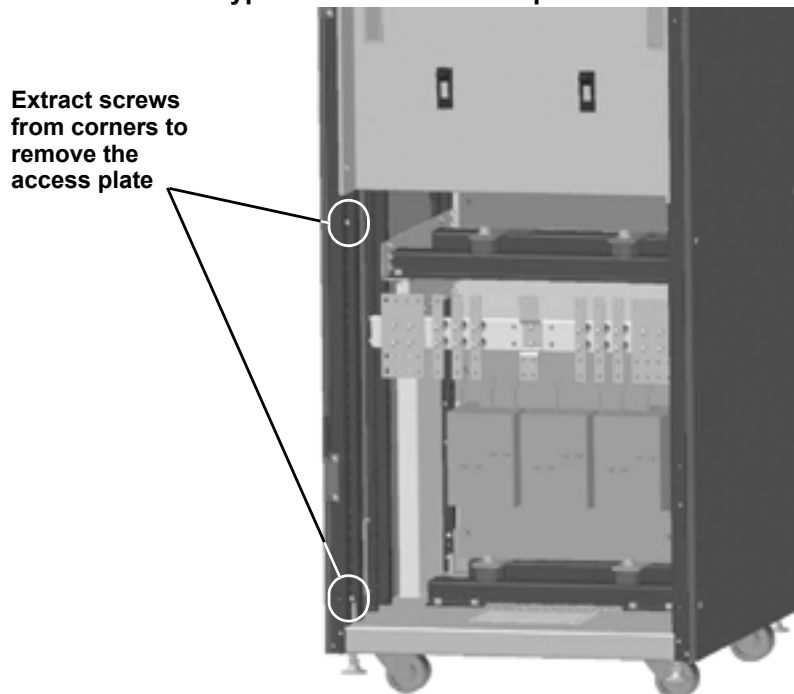



## 4.6.2 Power Cable Installation

Refer to **Tables 29, 30** and **32** when selecting cables.



### NOTE

*Transient and steady state earth leakage currents may occur when starting the equipment. This should be taken into account when selecting ground current detection devices because these will carry the earth leakage currents of both the UPS equipment and the load.*

## 4.6.3 Input/Output Wiring

Follow the steps below to connect the input wiring:



### NOTE

*Input wiring must be installed using conduit if cabinet is not mounted to the immediate left of the UPS.*

1. Locate the input wiring access (top or bottom access), remove the conduit landing plate and punch the appropriate size hole for the size conduit being used. Pull the three/four input wires through it, allowing some slack for installation. For cabinets that are located to the immediate left of the UPS, the access plate is on the lower right of the cabinet. Remove the access plate and verify that the edge guarding is installed and intact. See **Figure 19**.

**Figure 19 Maintenance Bypass Cabinet wiring access panel**

**Wiring access is on lower right side of Maintenance Bypass Cabinet**

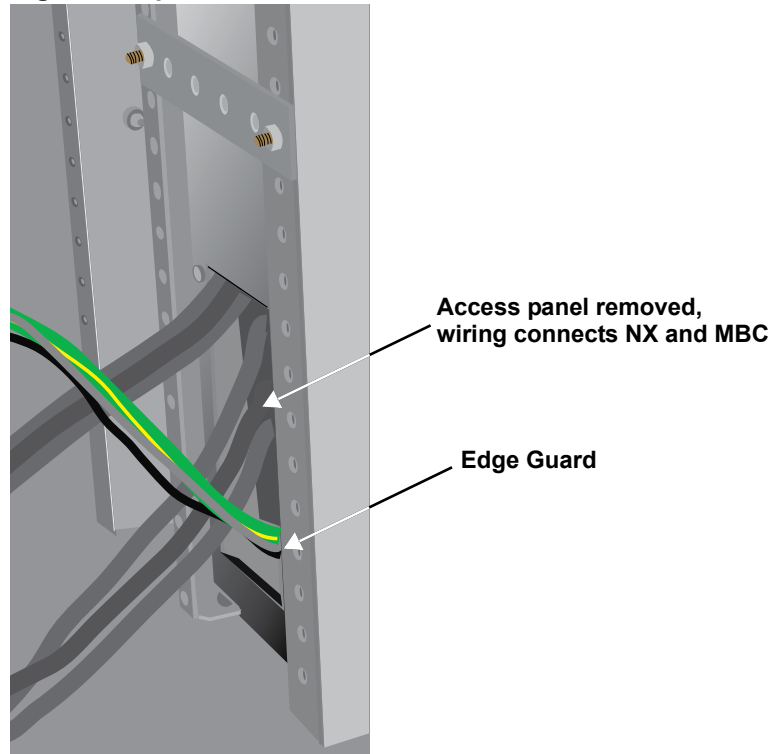

2. Secure the conduit to the access plate of the Maintenance Bypass Cabinet.
3. Input power cables connect to the system input circuit breaker. Refer to **Figure 35 - Maintenance Bypass interconnection**
4. Connect the ground (earth) wire to the earth busbar and tighten it to 44 lb-in. (5 N-m) (M6 bolt).
5. Locate UPS input and output cables and access panel to UPS on lower right side. See **Figure 19**.



### NOTE

*If the maintenance bypass cabinet is not to be bolted to the UPS, use either top or bottom access plate.*

6. Connect the system ground cable between the Maintenance Bypass Cabinet and UPS and tighten the connections to 44 lb-in. (5 N-m) (M6 bolt).

7. Connect the system input cables between the Maintenance Bypass Cabinet 'UPS Input' Busbars (A-B-C N terminals) and UPS input busbars (A-B-C N terminals) and tighten the connections to 44 lb-in. (5 N-m) (M6 bolt).
8. Connect the system output cables between the Maintenance Bypass Cabinet 'UPS Output' Busbars (A-B-C N terminals) and UPS output busbars (A-B-C N terminals) and tighten the connections to 44 lb-in. (5 N-m) (M6 bolt).
9. Connect supplied control wire to X3 on the Parallel (M3) board (see **Figure 20**).



## WARNING

The control wire must be installed to ensure proper operation of the system and fully protect the load when switching between bypass cabinet and UPS.

**Figure 20** Maintenance bypass control wire location

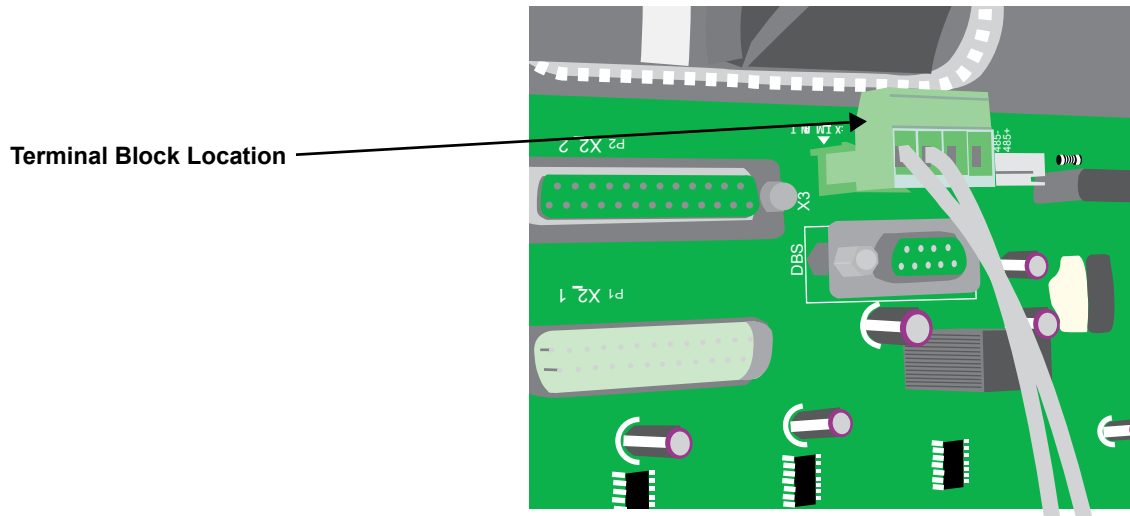

## NOTE

For startup procedure, see the UPS operations and maintenance manual, SL-25210.

## 4.7 Bolting Cabinets Together



### NOTE

*UPS wiring must be completed before the cabinets are bolted together.*

1. Line up cabinets so that mounting holes are aligned.

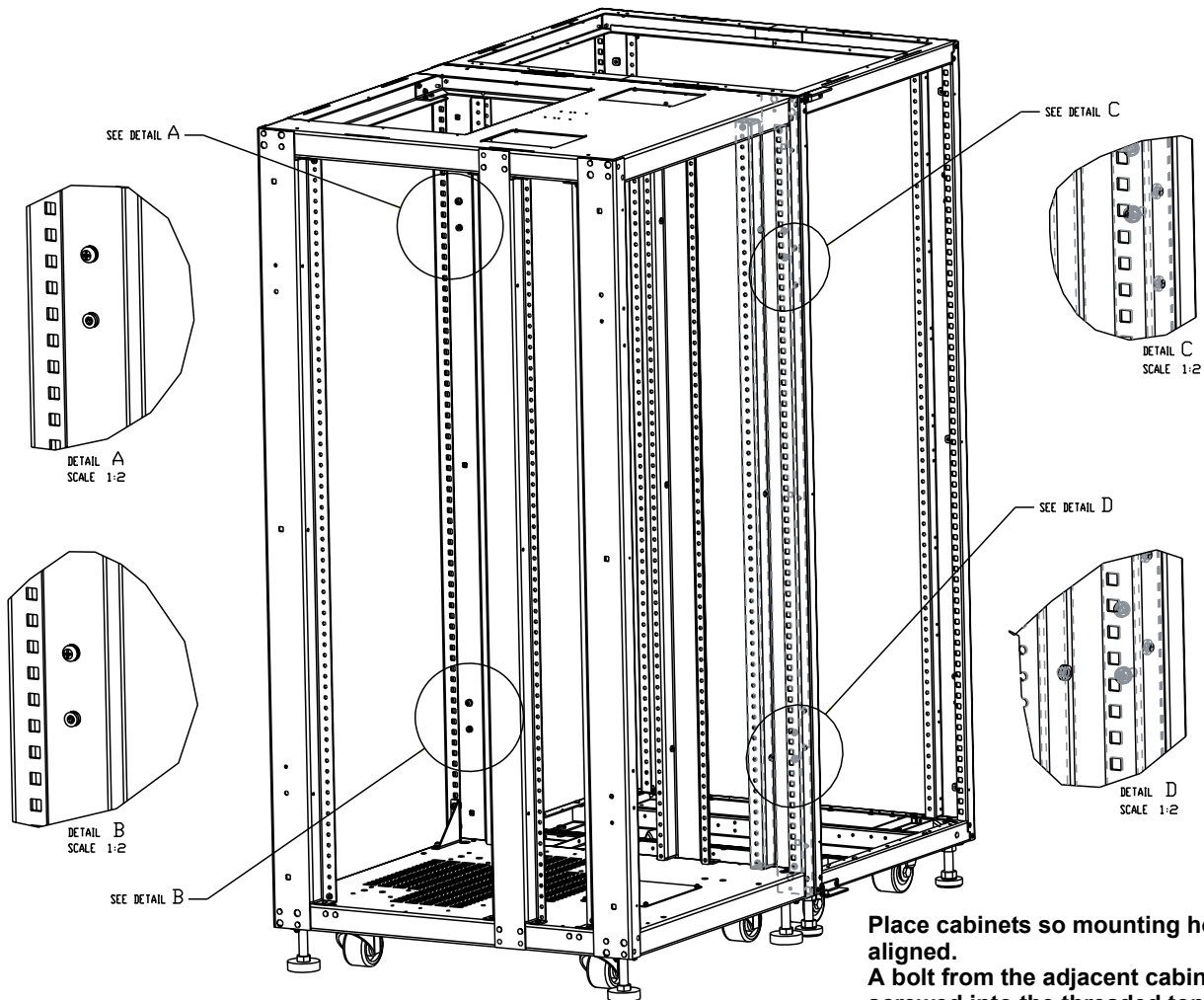

2. Using supplied hardware, bolt the cabinets together. The bolts may be inserted from either the UPS side or from the MBS side, whichever is more convenient.

## 5.0 OPTIONS

### 5.1 Load Bus Synchronization

The Load Bus Synchronizer (LBS) keeps the output of two independent UPS systems or parallel UPS systems in synchronization even when the systems are operating in different modes and even when either or both systems are operating on batteries. When the LBS is used, one UPS system is designated as master, the other as slave.

The LBS option is typically used with dual-corded equipment or with either the Liebert SmartSwitch or Static Transfer Switch (STS) for single-corded equipment.

#### 5.1.1 Performance Requirements

The DBS operates under the following conditions:

- Both master and slave are on inverter (either system may be on inverter through the rectifier or on inverter through the batteries)
- Master on inverter, and slave on bypass
- Master on bypass, and slave on inverter
- Master and slave on bypass IF the bypass source is the same for both systems

#### 5.1.2 DBS Cable and Settings

For NX-to-NX dual bus configuration, only one optional LBS cable is required, the built-in LBS will operate normally without extra LBS control box or interface box. The LBS port is X4 on the parallel board (M3). The parallel board is on the interior of the NX, above and left of the power electronics; see **Figure 30**.

An optional, 9-pin LBS cable is used to connect two UPS systems through each system's DB9 port on its parallel board. For two parallel systems, the LBS cable can be mounted between any two units belonging to different parallel systems. For information about the LBS kit or to order the optional equipment, see your local Liebert representative.

The LBS cable is connected as illustrated in **Figure 21**.

**Figure 21 Load Bus Synchronization cable connection**

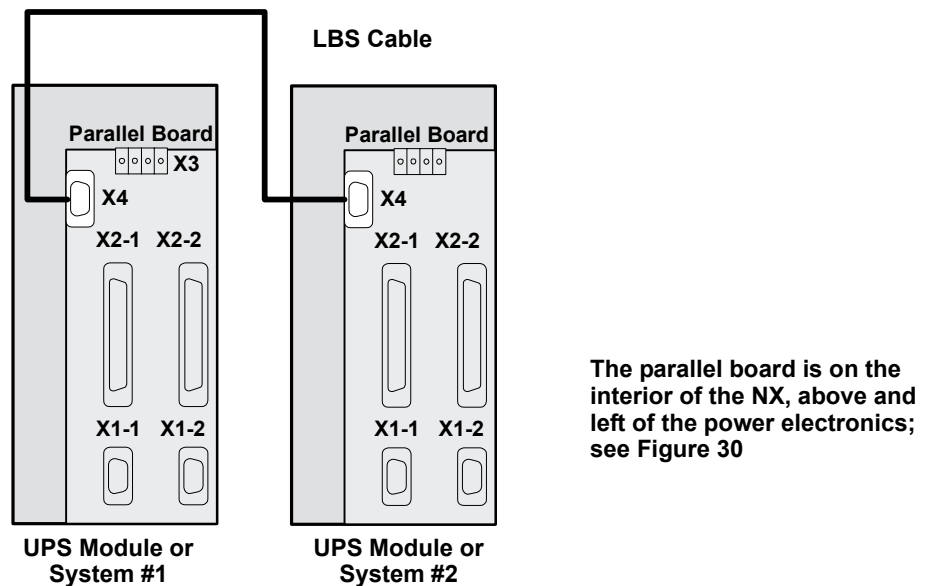

The LBS function is activated with configuration software; when the LBS takes effect, the graphic LCD will display "LBS active."

## 5.2 Configuring Parallel System Operation

### 5.2.1 General

The NX uses intelligent and reliable decentralized technology to achieve parallel operation of two or more modules of the same rating.

The 1+N system is used to:

- Increase the reliability of the system to ensure adequate power supply to the critical load connected.
- Increase serviceability and allow the execution of maintenance operations and reparations without affecting the ordinary operating conditions of the system (depending on the redundancy level).

### 5.2.2 Features of Parallel System

- The hardware and firmware for parallel UPS module operation is standard in the NX, and the configuration can be set up by changing the settings in configuration software.
- It is easy to install the parallel cables in a ring, providing high reliability and redundancy. And the intelligent paralleling logic provides the user with maximum flexibility. For example, shutting down or starting up the UPS modules in the parallel system can be done in any sequence. If an overload transfer occurs, the whole system can recover automatically from bypass mode after the overload is cleared.
- The total load of the parallel system can be queried from each module's liquid crystal display screen.

Figure 22 1+N system block diagram

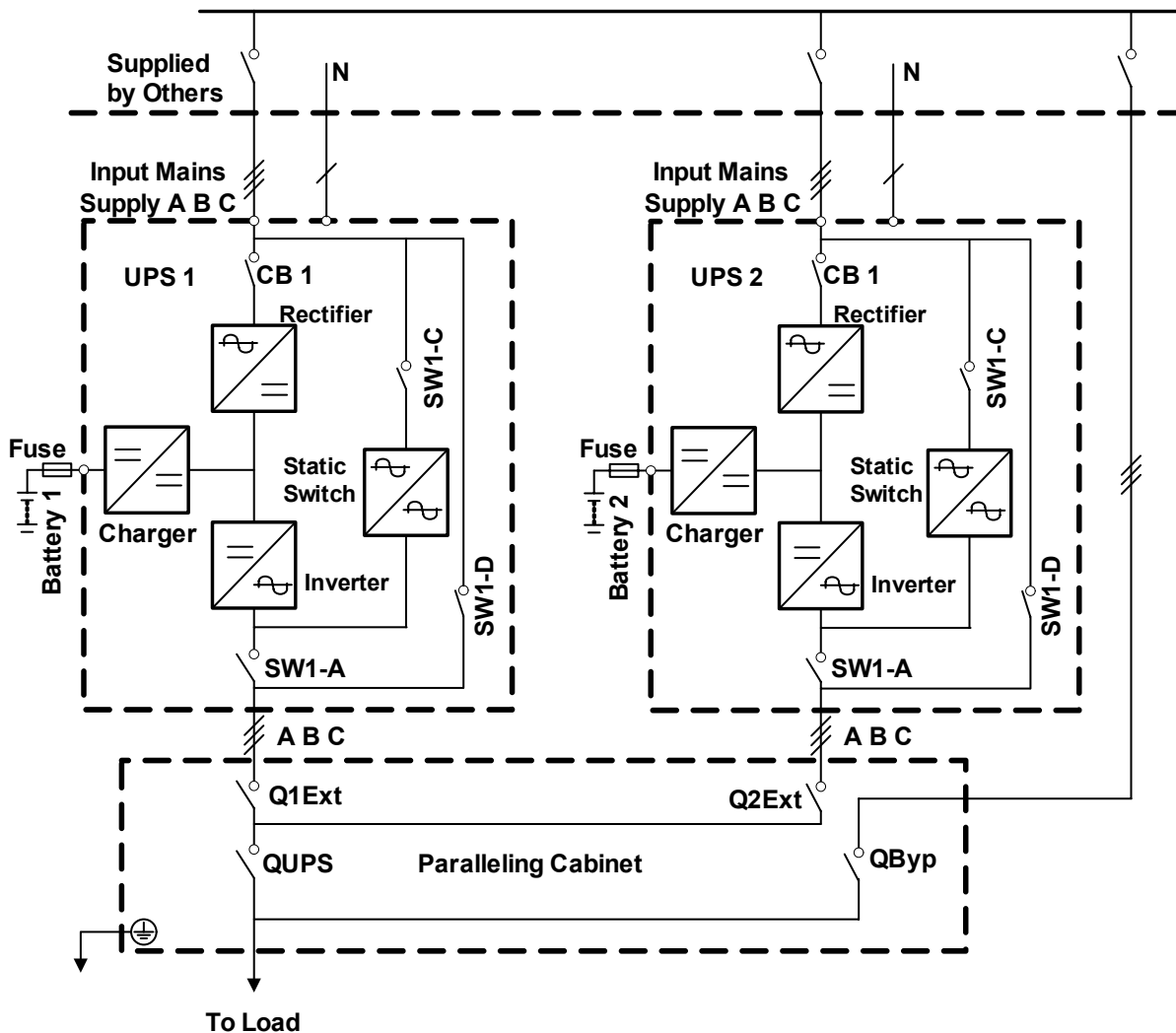

## 5.2.3 Operating Principles

### Redundancy Paralleling

The 1+N parallel redundant system can noticeably improve system reliability. In normal condition, none of the UPS modules work at full load. That means that even if the load is increased, the system will not transfer to bypass. And when a UPS module shuts down due to any failure, the remaining UPS modules can still power and protect the load. When redundancy is lost due to module failure or load increase, the parallel system will trigger an alarm.

## 5.2.4 Operation Modes Summary

The parallel system also has operation modes such as normal, battery, bypass and maintenance bypass. All UPS modules in the 1+N parallel system operate in coordination.

- **Normal Mode Operation**

The load is powered by the inverters of all the UPS modules in the system. If the frequency of bypass is within the synchronous range, the inverter will be synchronized with the bypass. Otherwise, the system will operate at nominal frequency.

- **Battery Mode Operation**

The batteries of all UPS modules power the load through their inverters. The system operates at nominal frequency.

- **Bypass Mode Operation**

The condition to transfer to bypass mode is essentially the same as that of single module system. The bypass of all the UPS modules powers the load.

- **Maintenance Bypass Mode Operation**

The sequence to transfer to maintenance bypass mode is the same as for transferring a single-module system. The maintenance bypass switches should be switched on as synchronously as possible. Thus the system can be repaired without interrupting the power supply to critical load.

## 5.3 Installing Parallel System

The basic installation procedure of parallel system is the same as that of single module system. The following sections introduce only the installation procedures specific to the parallel system.

### 5.3.1 Conditions for Parallel System

- Each UPS module should have the same rating, the same firmware and hardware version.
- Each UPS module must have the same bypass source.
- The outputs of all UPS modules are connected altogether.
- The main inputs can be from different sources, but the phase rotation sequence of main inputs, bypass inputs and outputs must be correct and the same.
- The parallel logic cable and load sharing cable must be connected in a ring correctly (see **Figure 23**).

### 5.3.2 Cabinet Installation

#### Parallel system composed of two or more UPS modules using parallel cabinet

The UPS modules that will form the 1+N system should be placed side-by-side. Each battery cabinet is placed next to its corresponding UPS module.

The parallel cabinet should be placed in the middle of the system.

### 5.3.3 Preliminary Checks

Each UPS module should have the same rating, the same firmware and the same hardware version. Refer to the instructions in **5.3.1 - Conditions for Parallel System**.

### 5.3.4 Protective Devices

For each UPS, refer to **Table 10**. For each system, refer to **Table 31**.

### 5.3.5 Power Cables

Wiring of power cables is similar to that of single module system (See **2.1 - Power Cabling**). The bypass sources of all modules should be the same, and the outputs should be connected altogether correctly.

Power cables will be supplied by customer. Power cables to the UPS's of the 1+N paralleling cabinet must be routed through either the top or bottom entry access of the UPS.

For systems using a parallel cabinet, see **Figures 36** and **38** through **44** for power cable terminations.



#### NOTE

*The length and specifications of power cables including the bypass input cables and UPS output cables should be the same, thus the load can be shared evenly in bypass mode.*

### 5.3.6 Parallel Control Cables

#### Parallel System Control Cables

Make the connections listed below on the parallel logic board (M3) inside the NX. (See **Figure 30** for the location of the parallel logic board):

Shielded and double-insulated control cables available in lengths of up to 100 feet (30m) must be interconnected in a ring configuration between UPS modules as shown below. The ring configuration ensures high reliability of the control (refer to **Figure 23**).

See **Figure 25** for dry contacts control cable wiring diagram.

**Figure 23** Connecting '1+N' system parallel control cables

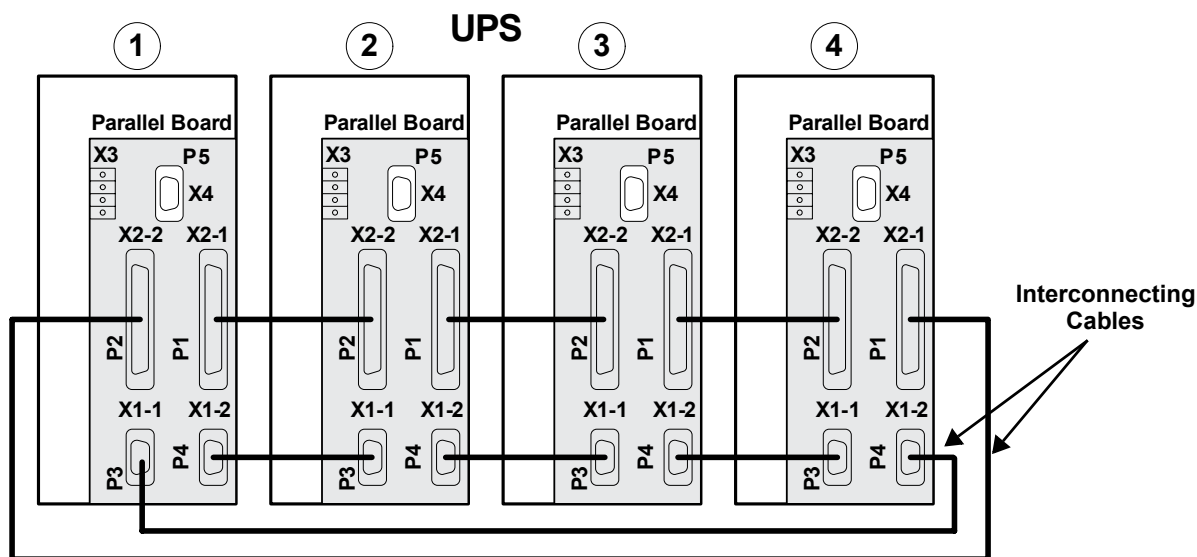

#### Auxiliary Dry Contact Cables

The external output breaker of each UPS must have Normally Open auxiliary contacts. These contacts must be wired to connector X3 on the Parallel Logic Board (M3). See **Figure 24**.

Figure 24 Auxiliary dry contact cables for output breaker in multi-module system

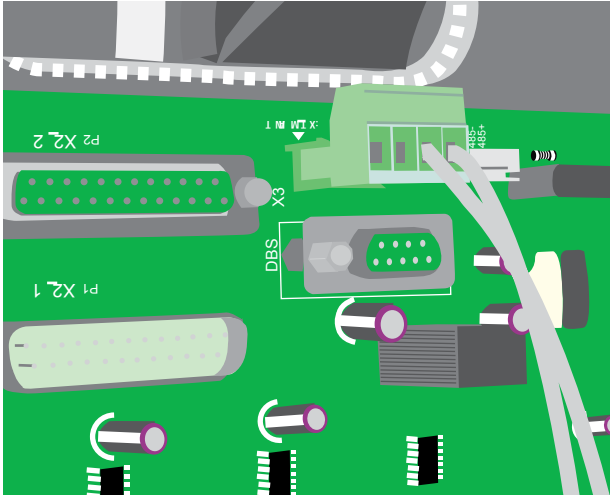

**CAUTION**

The auxiliary control wire must be installed to ensure proper operation of the system.



**NOTE**

For startup procedure, see the UPS operations and maintenance manual, SL-25210.

Figure 25 Dry contacts, multiple UPS modules with distribution panel

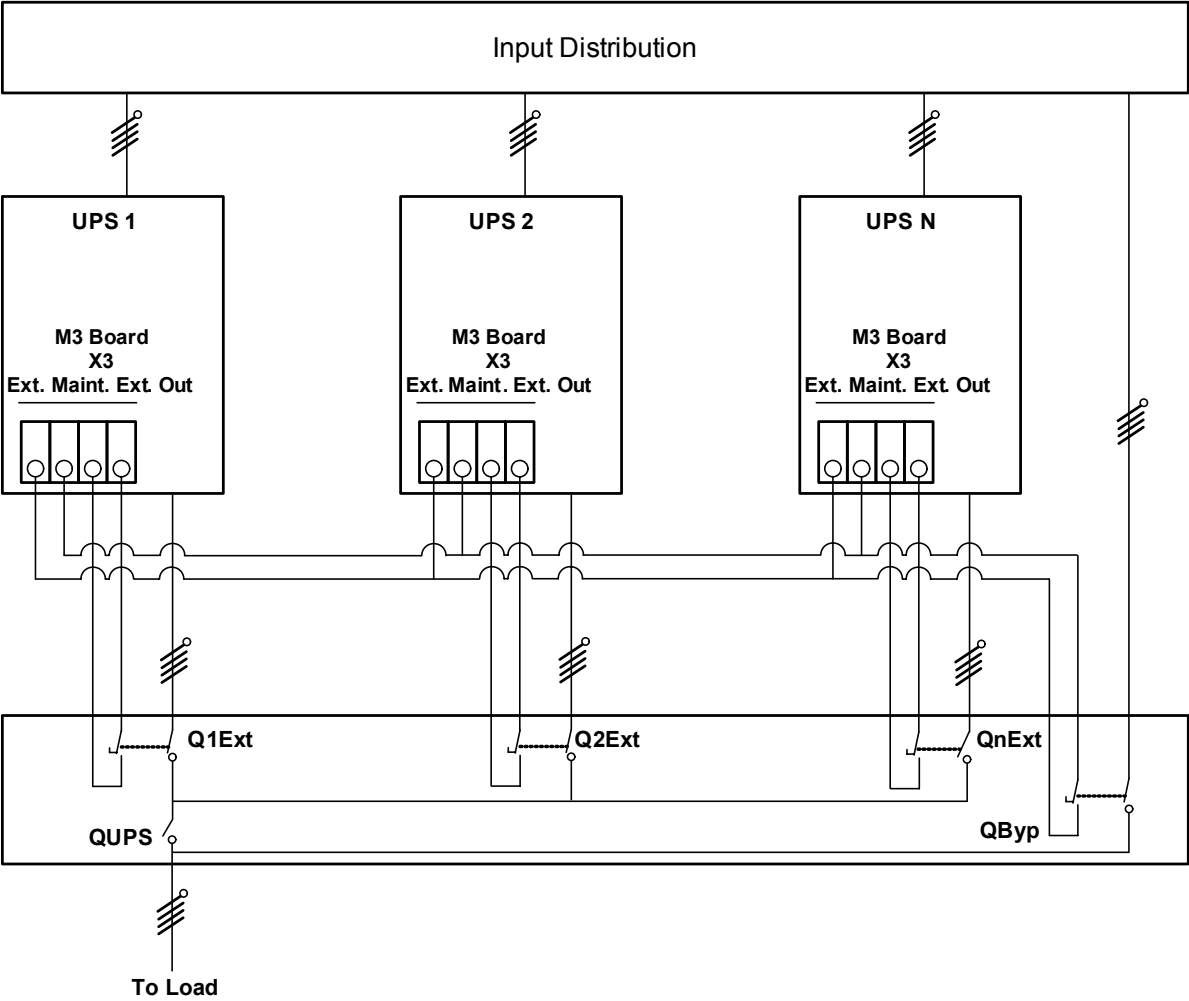



### 5.3.7 Emergency Power Off (EPO)

The external emergency stop facility is identical to that described for the single unit installation—that an individual emergency stop button is provided for each unit.

Figure 26 Connecting EPO push button

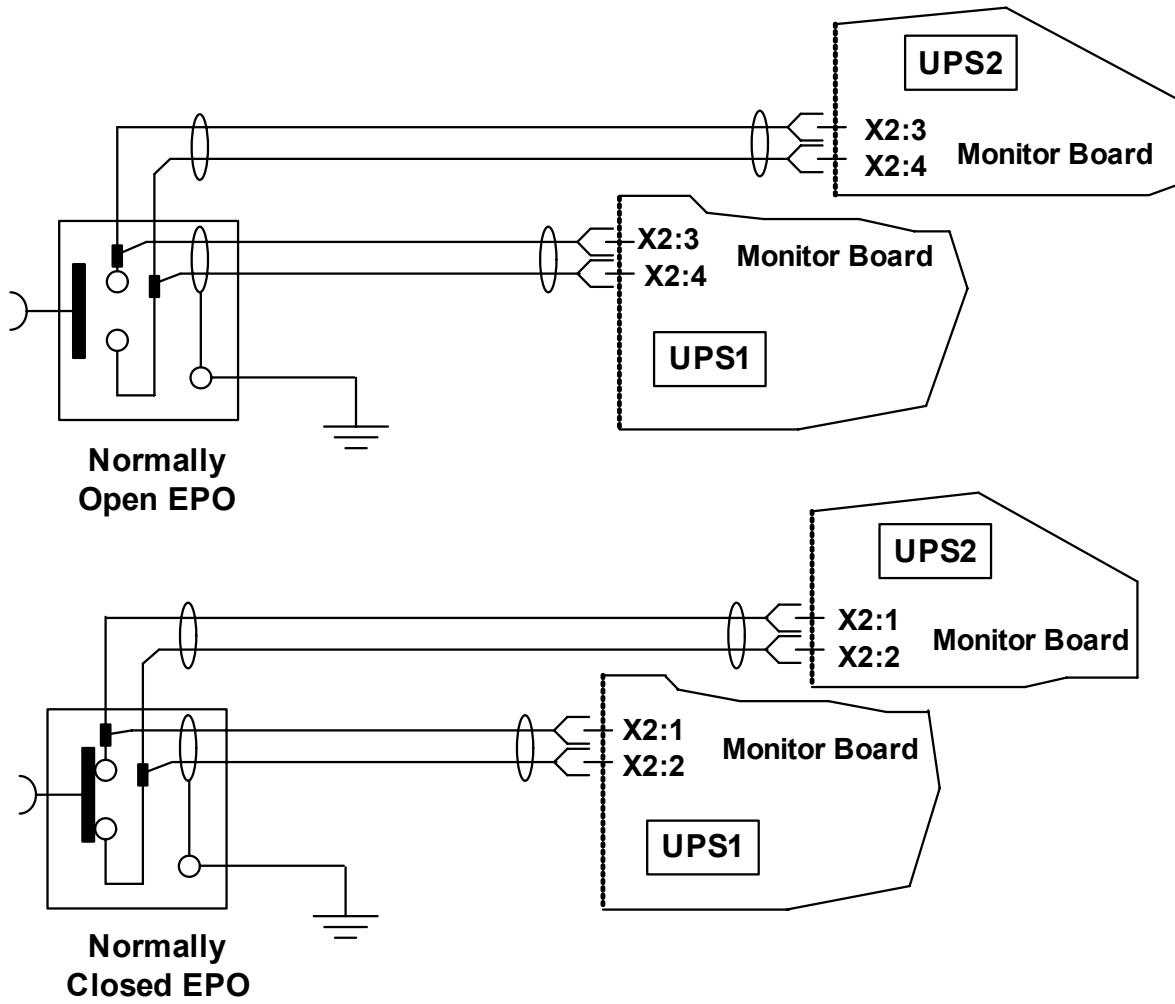

## 5.4 Battery Circuit Breaker Box

The box contains the same battery isolating circuit breaker as mounted in the battery cabinet.

Two battery circuit breaker boxes are available for use in installations where the battery is not installed in the battery cabinet, in which case the appropriate battery box is fitted as close as possible to the battery and connected to the UPS equipment as illustrated in **Figure 27**.

The battery circuit breaker box, is required to protect the battery from overcurrents. It also provides electrical isolation between the UPS and the battery, permitting technical service personnel to reduce the risks involved in maintenance work to a minimum.

A separate safety earth must be connected between the UPS unit and circuit breaker box.

Two boxes are available depending on the UPS power rating.

**Table 7 Available battery circuit breaker boxes**

UPS	Dimensions (in) H-W-D	Circuit Breaker
10-15 kVA	32.25x20.25x8.3	70A
20-30 kVA	32.25x20.25x8.3	125A

The circuit breaker has the following features:

- Short-circuit protection.
- Protection against battery cabinet and ups connection errors (polarity reversal +/-).

Figure 27 Battery circuit breaker box connections

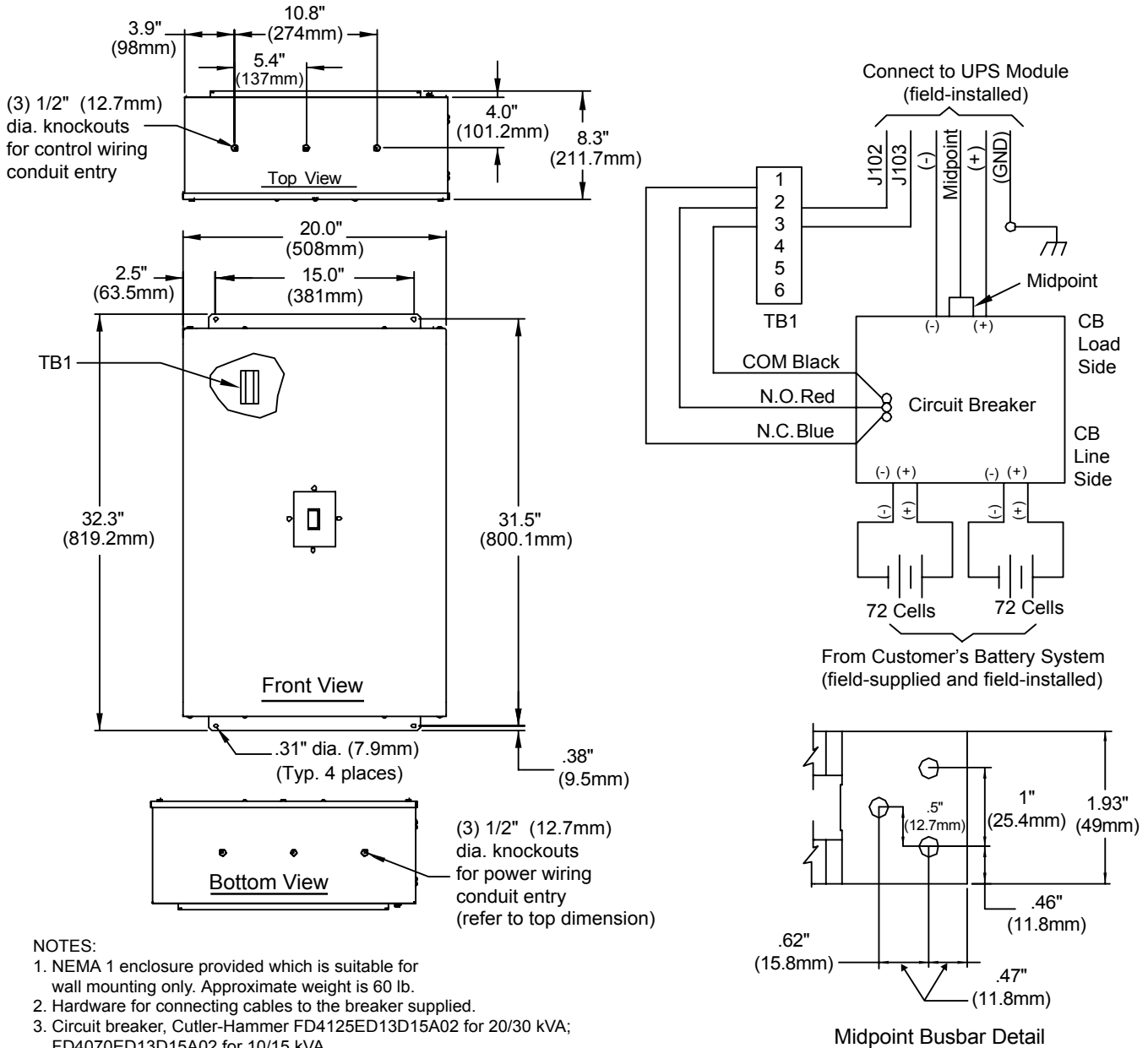

## NOTES:

- NEMA 1 enclosure provided which is suitable for wall mounting only. Approximate weight is 60 lb.
- Hardware for connecting cables to the breaker supplied.
- Circuit breaker, Cutler-Hammer FD4125ED13D15A02 for 20/30 kVA; FD4070ED13D15A02 for 10/15 kVA
- Color: IBM off-white.
- Mount enclosure and pull all cables into enclosure before installing dry contacts.
- Low voltage wiring needs to enter from the top of the enclosure, in separate conduit from power cables.
- Line side power connections to lugs: (1) # 6AWG per connection for 10 to 15 kVA. (1) # 2AWG per connection for 20-30 kVA to lugs; load side power connections to busbars; see detail.
- Power cables must be sized to limit voltage drop from battery system to UPS to be a maximum 4 VDC.

DPN U3813078 Rev. N

**NOTE**

- The signal cables in this figure must be shielded and double-insulated.
- Connect the Pes (Protection Earth) of the UPS cabinet and BCB box to the same point.

## 6.0 UPS SPECIFICATIONS

These specifications describe requirements for the Liebert NX UPS.

### 6.1 Conformity and Standards

The UPS has been designed to conform to the following standards:

- IEEEC1000-4-5
- ASME
- CSA 22.2, No. 107.1
- FCC Part 15, Class A
- ISO 9001
- National Electrical Code (NFPA-70)
- NEMA PE-1
- OSHA
- UL Standard 1778

The UPS system has UL and c-UL approval.

### 6.2 UPS Environmental

The UPS is designed to operate under the following environmental conditions without damage or degradation in electrical operating characteristics:

**Table 8 Environmental characteristics**

Rated Power	10-30kVA
Operating Temperature, UPS	32°F to 104°F (0°C to 40°C)
Optimal Operating Temperature, Battery	68°F to 86°F (20°C to 30°C)
Relative Humidity	0 to 95%, non-condensing
Acoustical Noise, dBA at 39 in. (1m)	54
Altitude of Operation	≤1000m per IEC 62040/3
Storage-Transport Temperature, UPS	-4°F to 158°F (-20°C to 70°C)
Storage-Transport Temperature, Battery	-4°F to 86°F (-20°C to 30°C)

### 6.3 UPS Mechanical Characteristics

**Table 9 Mechanical characteristics**

Parameter	10kVA	15kVA	20kVA	30kVA
Width, in. (mm)	24 (600)			
Depth, in. (mm)	32.5 (825)			
Height, in. (mm)	63 (1600)			
Weight Without Inner Batteries, lb. (kg)	450 (205)	450 (205)	550 (250)	550 (250)
UPS12-100 weight	954 (433)	954 (433)	1054 (478)	1054 (478)
UPS12-140 weight	1098 (498)	1098 (498)	1198 (543)	1198 (543)
Heat Dissipation, BTU/H (kWH)	2800 (0.82)	4200 (1.23)	5500 (1.61)	8300 (2.43)
Airflow, CFM (m <sup>3</sup> /h)	384 (652)	558 (948)	522 (886)	834 (1417)
Cable Entry	Bottom or top			
Color	PMS 877			
Protection Grade (with open/closed front doors)	IP 20			

## 6.4 UPS Electrical Characteristics

Table 10 UPS terminal

### Input (for single-input unit)

Unit Rating	Nominal Input Current	Maximum Input Current	OCP Current	OCP Device Rating	Bolt Size	Maximum Recommended Lug	
						Lug T&B One Hole 54000	Lug T&B One Hole REDDY
10	28	35	42	45	6M (1/4")	54105	62204
15	42	53	63	70	6M (1/4")	54106	62204
20	56	70	84	90	6M (1/4")	54107	62204
30	83	104	125	125	6M (1/4")	54152	62205

### Rectifier input (for dual input unit only)

Unit Rating	Nominal Input Current	Maximum Input Current	OCP Current	OCP Device Rating	Bolt Size	Maximum Recommended Lug	
						Lug T&B One Hole 54000	Lug T&B One Hole REDDY
10	25	31	37	40	6M (1/4")	54130	62204
15	37	47	57	60	6M (1/4")	54106	62204
20	50	63	76	80	6M (1/4")	54107	62204
30	75	94	113	125	6M (1/4")	54152	62205

### Bypass input (for dual input units)

Unit Rating	Nominal Input Current	OCP Current	OCP Device Rating	Bolt Size	Maximum Recommended Lug	
					Lug T&B One Hole 54000	Lug T&B One Hole REDDY
10	28	35	35	6M (1/4")	54105	62204
15	42	53	60	6M (1/4")	54106	62204
20	56	70	70	6M (1/4")	54107	62204
30	83	104	110	6M (1/4")	54152	62205

### Output

Unit Rating	Nominal Output Current	OCP Current	OCP Device Rating	Bolt Size	Maximum Recommended Lug	
					Lug T&B One Hole 54000	Lug T&B One Hole REDDY
10	28	35	35	6M (1/4")	54130	62204
15	42	53	60	6M (1/4")	54106	62204
20	56	70	70	6M (1/4")	54106	62204
30	84	105	110	6M (1/4")	54108	62205

### Battery

Unit Rating	Battery Current	OCP Current	OCP Device Rating	Bolt Size	Maximum Recommended Lug	
					Lug T&B One Hole 54000	Lug T&B One Hole REDDY
10/15	55	55	70	6M (1/4")	54106	62204
20/30	110	110	125	8M (5/16")	54153	62212

### 6.4.1 Battery Manufacturers and Models

Either of two manufacturers' batteries will be installed in the NX 10-30 kVA 208V as shipped. Below are the battery makers and the models they supply.

**Table 11 Approved batteries**

Battery Manufacturer	Models Supplied		
Enersys Yuasa	NPX-80FR	NPX-100FR	NPX-150FR
C&D Dynasty	UPS12-100MR	UPS12-140MR	-

### 6.4.2 Input Rectifier

**Table 12 Rectifier input power**

Rated Power	10kVA	15kVA	20kVA	30kVA
Rated Voltage, VAC	120/208			
Supply	3-phase, 4-wire plus ground			
Input Voltage Tolerance, VAC (without derating)	166-239			
Frequency, Hz	50 / 60			
Input Frequency Tolerance %	±10			
Power Factor	≤ 0.99 at full load ≤ 0.95 at 50% load			
Harmonic Current	Less than 4% at full rated UPS output load			
Input Current, <sup>1</sup> Nominal, A	28	42	56	83
Output Current, Nominal, A	28	42	56	83

**Notes:**

- Overload capacity of input current:
  - 100% I<sub>max</sub> < I < 125% I<sub>max</sub>: 10 min.
  - 125% I<sub>max</sub> < I < 150% I<sub>max</sub>: 1 min.
  - I > 150%: Limits input current immediately

### 6.4.3 DC Intermediate Circuit

**Table 13 DC intermediate circuit**

Rated Power	10kVA	15kVA	20kVA	30kVA
Recommended number of lead-acid batteries	Number of batteries is 24 jars (12V per jar), or 144 cells (2V per cell) for VRLA. The unit is shipped with a nominal voltage of 288VDC.			
Recommended float charge voltage	2.27VDC*			
Recommended boost charge voltage	2.3VDC*			
Recommended end of discharge voltage	1.65-1.8 VDC			
Maximum recharge battery current, A	7.5	7.5	15	15
Maximum boost charge duration, min.*	1440			
Boost-float threshold current, A*	0.1 C default			
Temperature voltage compensation, mV/°C*	3			
Ripple voltage superimposed %	≤ 1			

\* Set by configuration software and based on usage of VLRA batteries.

### 6.4.4 Inverter Output

**Table 14 Inverter output**

Rated Power	10kVA	15kVA	20kVA	30kVA
Rated voltage, VAC	120/208			
Supply	3-phase, 4-wire plus ground			
Frequency, Hz	50 / 60			
Rated Power, kW	8	12	16	24
Three -phase transient overload, min. load	10 minutes - 105-125% load			
	1 minute - 126-150% load			
Voltage Regulation %	±1.0% three-phase RMS average for a balanced three-phase load ±2.0% three-phase RMS average for a 100% unbalanced load			
Frequency Regulation %	Nominal frequency regulation is ±0.05% in single module mode, and+/- 0.25% in parallel mode.			
Maximum rate of change of frequency, Hz/sec	For single mode, the slew rate is adjustable from 0.1Hz/s to 3Hz/s			
Current rating of neutral cable, A	1.5 x input current			

### 6.4.5 Bypass Input

**Table 15 Bypass input**

Rated Power	10kVA	15kVA	20kVA	30kVA								
Rated voltage, VAC	120/208											
Supply	Three-phase, 4-wire plus ground											
Rated Current, A												
208VAC	28	42	56	83								
Bypass voltage tolerance %	Upper limit: +10%, +15% or +20% Lower limit: -10%, -20%, -30% or -40%		Upper limit default: +15% Lower limit default: -20%									
Frequency, Hz	50 / 60											
Input frequency tolerance %	± 10 or ± 20%; default ±10%											
Current rating of neutral cable, A	1.5 x input current											
Bypass overload capacity (all ratings)			<table border="0"> <tr> <td style="text-align: center;"><b>Time</b></td> <td style="text-align: center;"><b>Load</b></td> </tr> <tr> <td>Long-term operation:</td> <td>&lt;135% load</td> </tr> <tr> <td>10 minutes:</td> <td>135% - 170% load</td> </tr> <tr> <td>100milliseconds:</td> <td>1000% full UPS rated output current</td> </tr> </table>		<b>Time</b>	<b>Load</b>	Long-term operation:	<135% load	10 minutes:	135% - 170% load	100milliseconds:	1000% full UPS rated output current
<b>Time</b>	<b>Load</b>											
Long-term operation:	<135% load											
10 minutes:	135% - 170% load											
100milliseconds:	1000% full UPS rated output current											

## 7.0 INSTALLATION DRAWINGS

The diagrams in this section illustrate the key mechanical and electrical characteristics of the NX UPS System cabinets.

**Figure 28 Dimensional view- front and left side views**

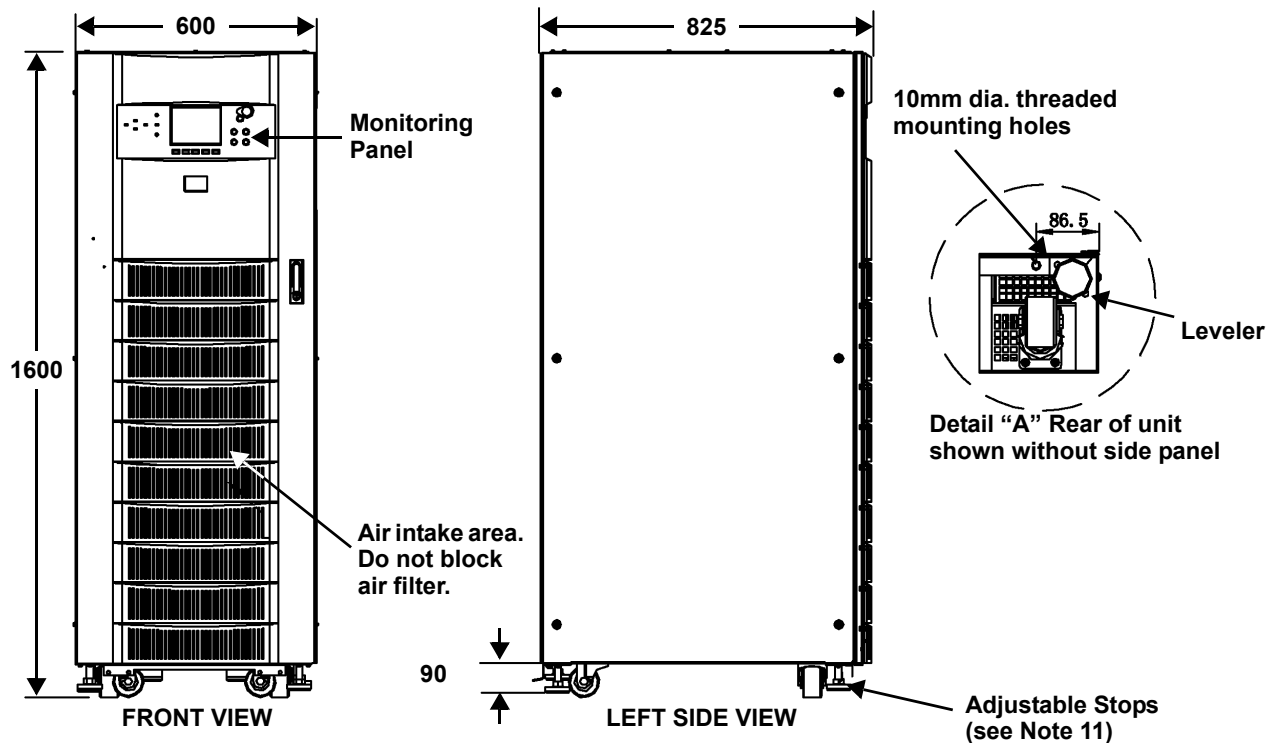

1. All dimensions are in millimeters.
2. A minimum of 24 inches clearance above the unit is required for air exhaust.
3. Installation and service access required. Left-side access recommended for maximum ease of installation.
4. Keep cabinet within 15 degrees of vertical while handling.
5. Top and bottom cable entry available through removal access plates. Remove punch to suit conduit size and replace.
6. Unit bottom is structurally adequate for forklift handling.
7. Open door to replace air filter, washable type, size 354x314.
8. Threaded mounting holes used for seismic anchoring or floor stand. **Note:** If a floor stand is used, the weight of the unit must be supported under all casters.
9. Each mounting location is supported by two 10 GA. (.135") galvanized steel. The threaded 12mm insert is approximately 3/4" deep. Mounting bolts must be threaded into unit.
10. Includes side panel. Refer to Detail A for dimension to frame with side panel removed. Side panels are removed between adjacent units that are bolted together.
11. Adjustable stops are not designed to carry the full weight of the cabinet. Finger-tighten stop against the floor, then tighten with a wrench less than two turns for friction against the floor.



Figure 29 Dimensions continued—top and bottom views

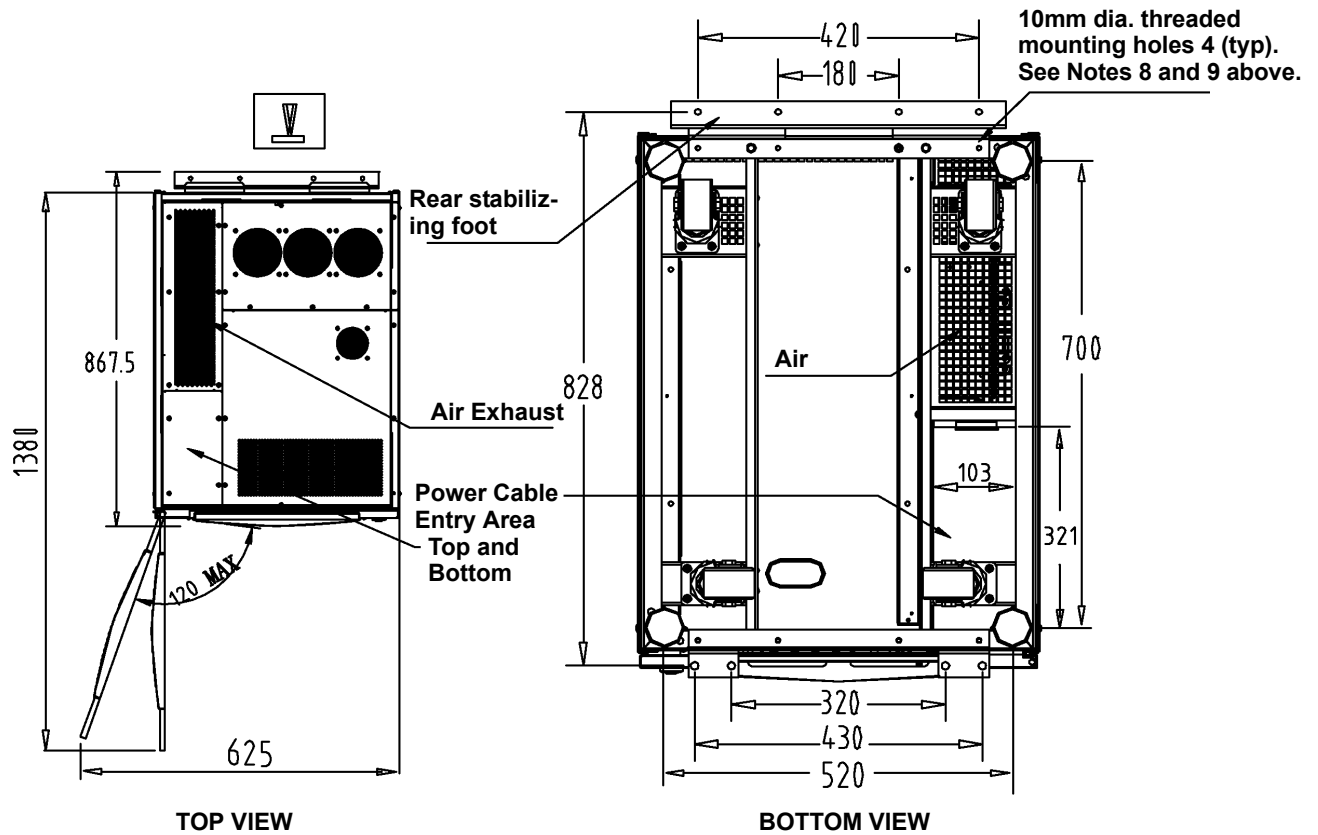

Figure 30 Main components—typical unit

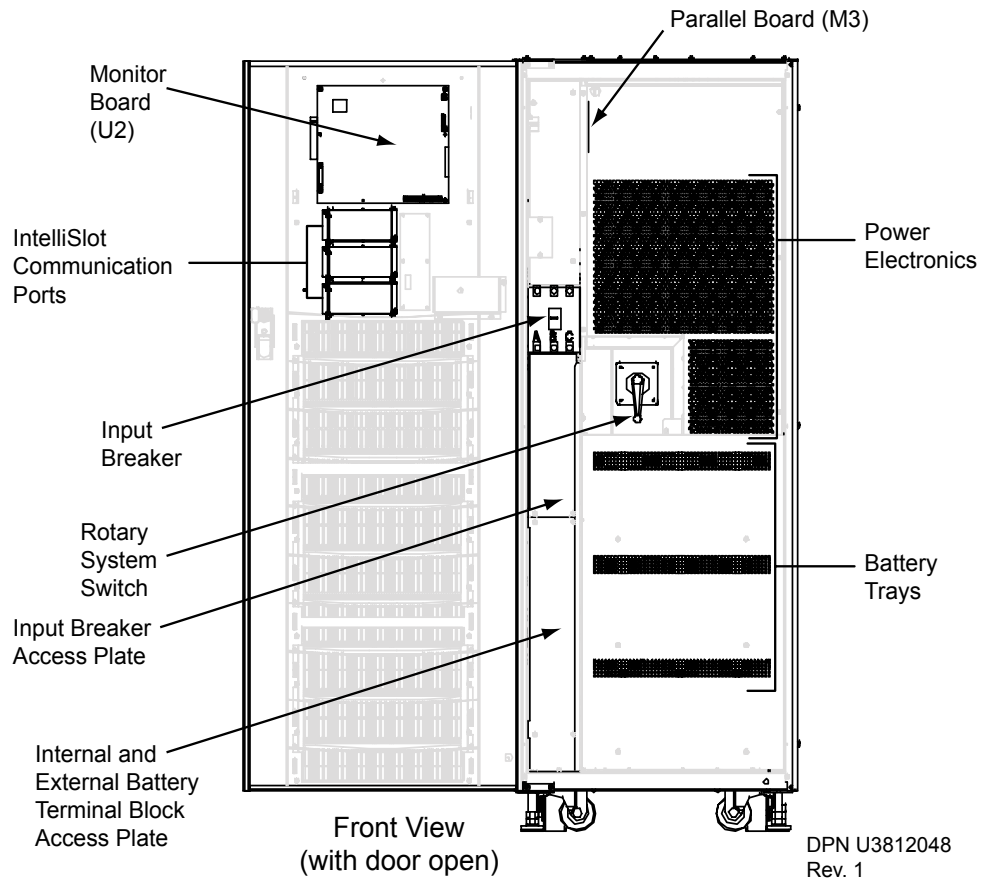
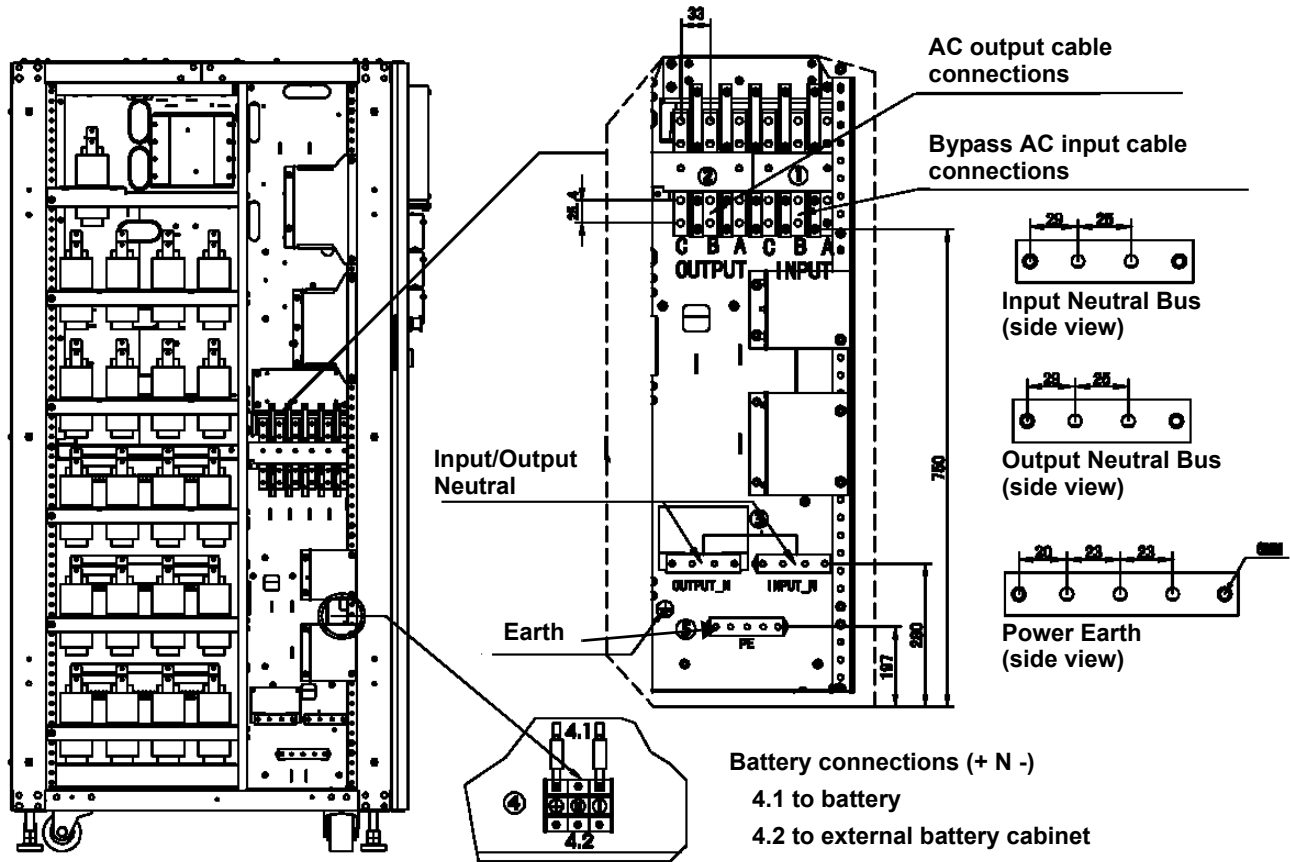

Figure 31 Cable connections



**NOTES**

1. All dimensions are millimeters.
2. Top and bottom cable entry available through removable access plates. Remove, punch to accommodate conduit size and replace.
3. Control wiring and power wiring must be run in separate conduit. Output and input cables must be run in separate conduit.
4. Aluminum and copper-clad aluminum cables are not recommended.
5. All wiring is to be in accordance with national and local electrical codes.

Figure 32 Location of internal batteries

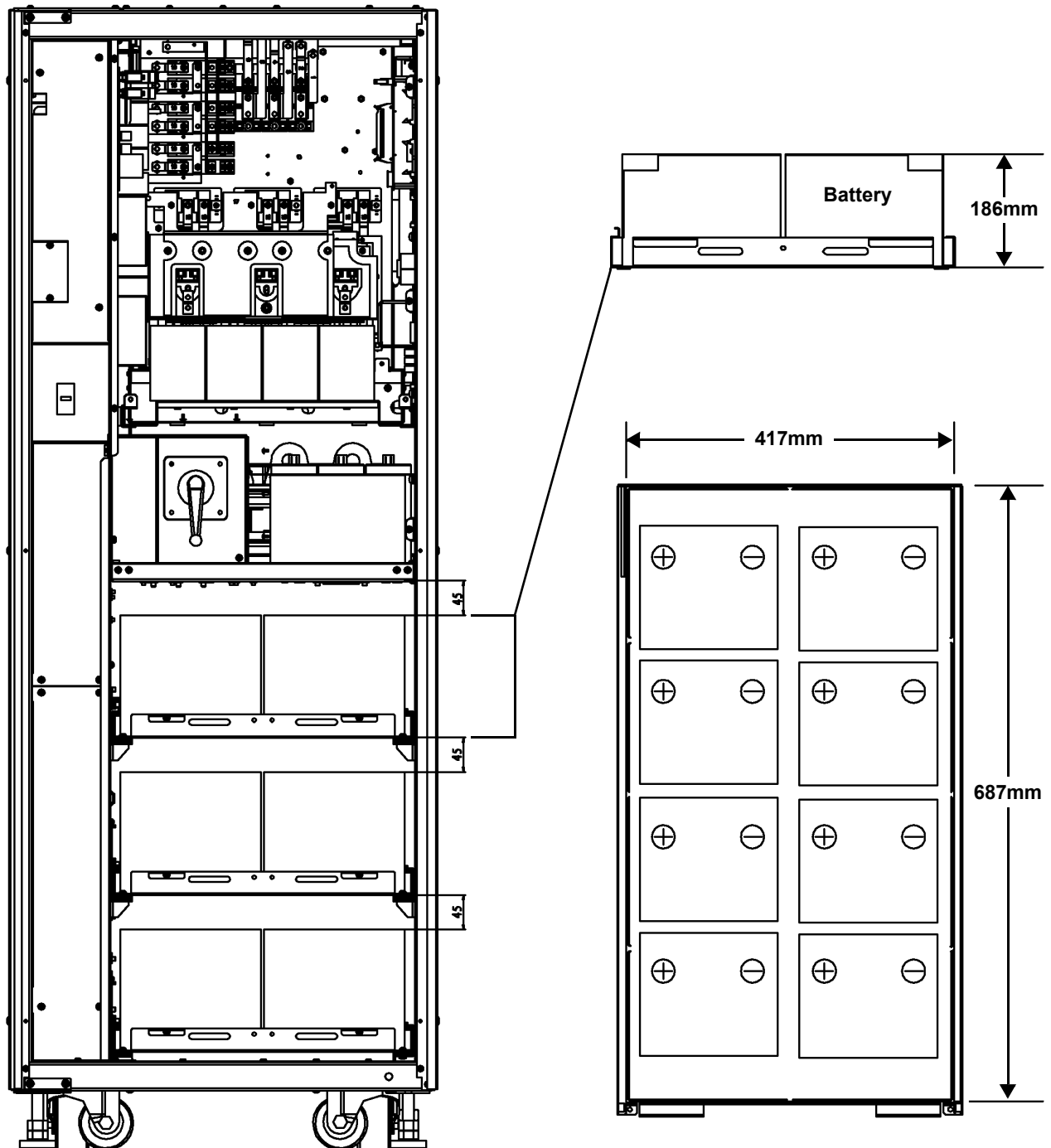

Figure 33 Battery connections

DYNASTY BATTERY

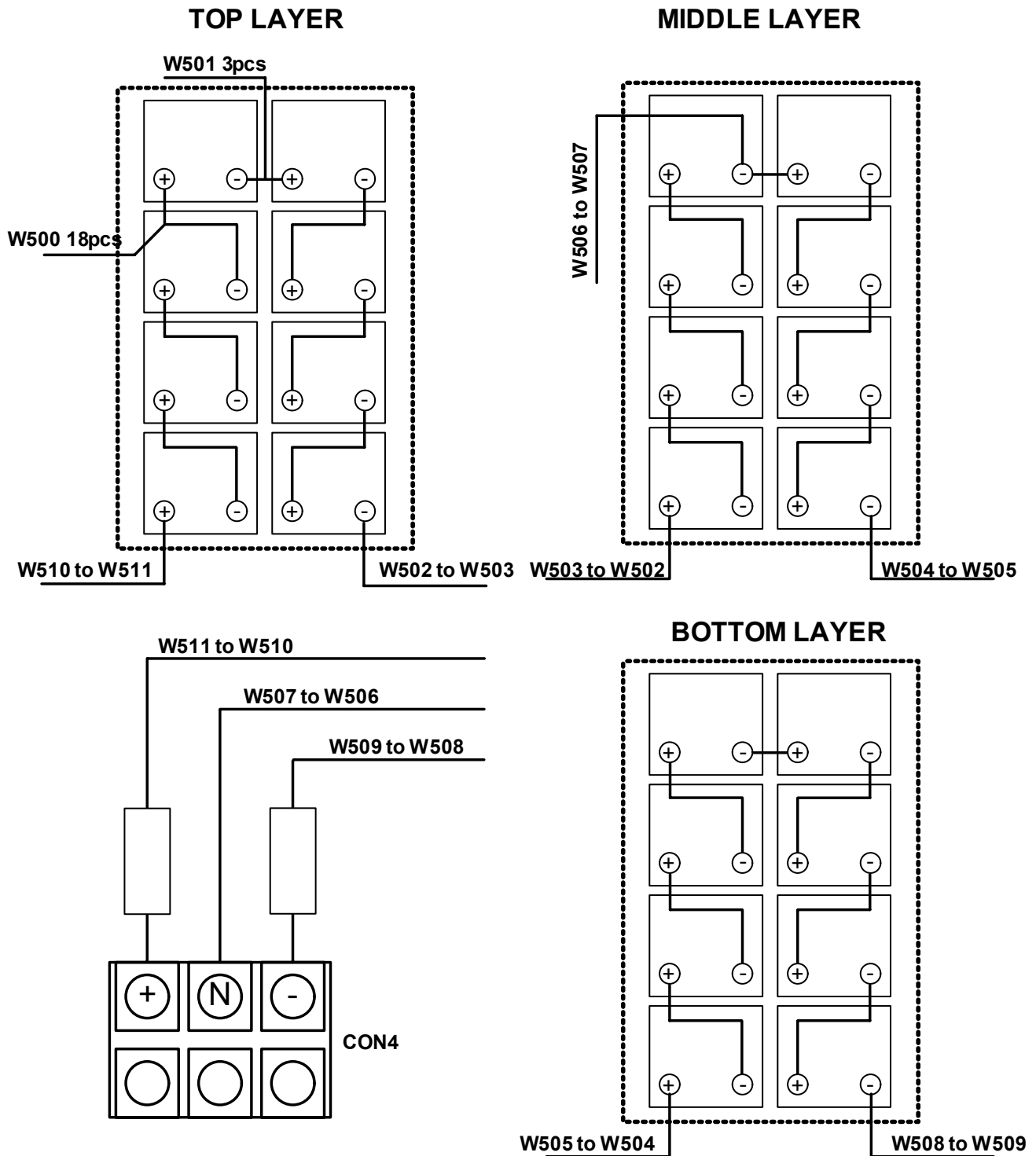
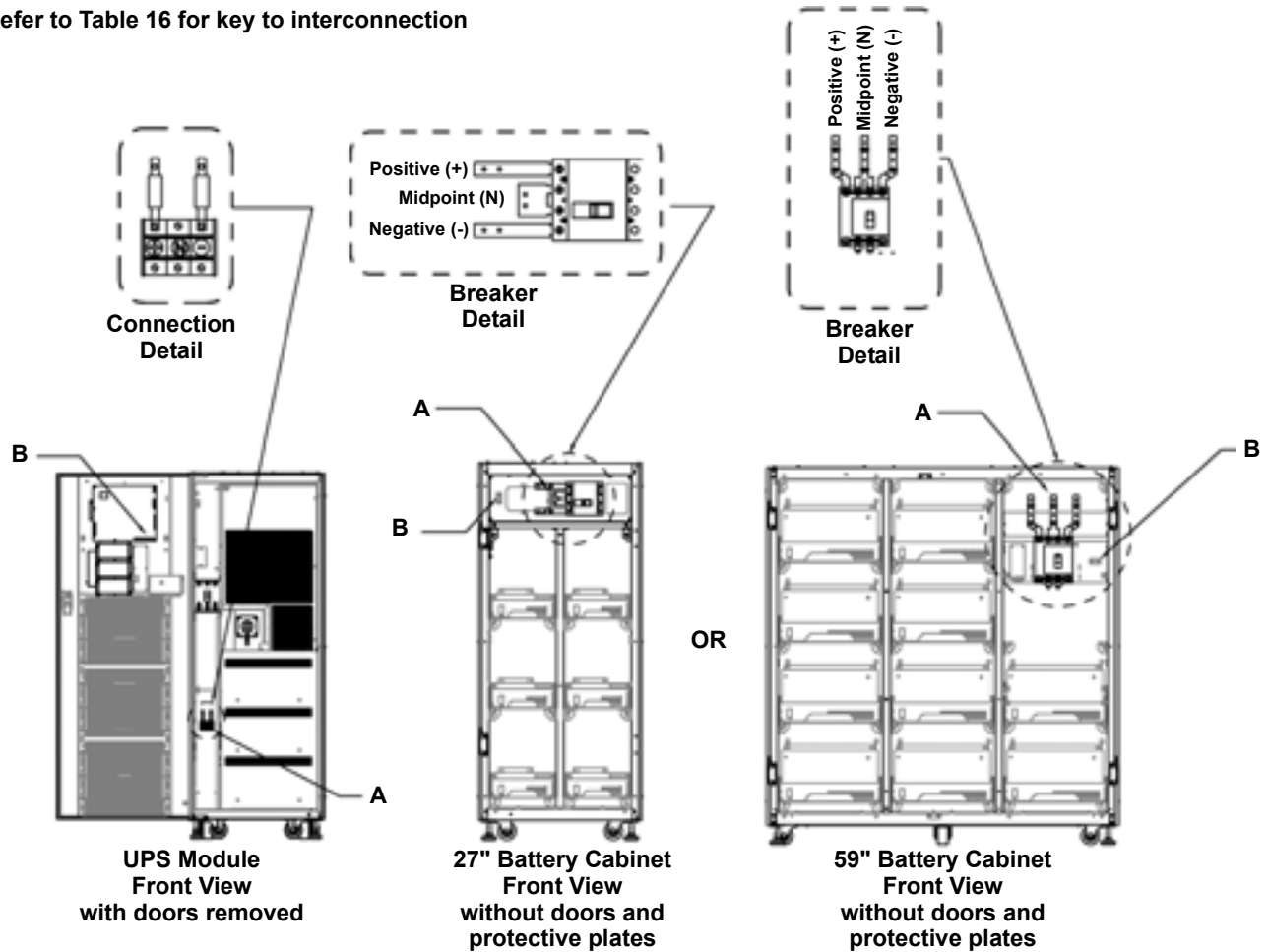

Figure 34 Battery cabinet interconnection

Refer to Table 16 for key to interconnection



**NOTES:**

1. All Liebert-supplied cable must be repositioned prior to and while the cabinets are being placed in their final installed location.
2. All interconnection hardware supplied by Liebert
3. All interconnection cables supplied by Liebert when bolted together.
4. Interconnection cables field-supplied when battery cabinets are stand-alone.
5. Refer to the individual drawing of each piece of equipment for additional details.

Table 16 Liebert -supplied interconnect wiring

Run	From	To	Conductors
A	UPS battery terminal block	External 27" or 59" battery cabinet	Positive, midpoint, negative
B	Battery cabinet terminal block	UPS monitor board	Battery breaker aux contacts

**Figure 35 Maintenance Bypass interconnection**  
 Refer to Table 17 for key to interconnection

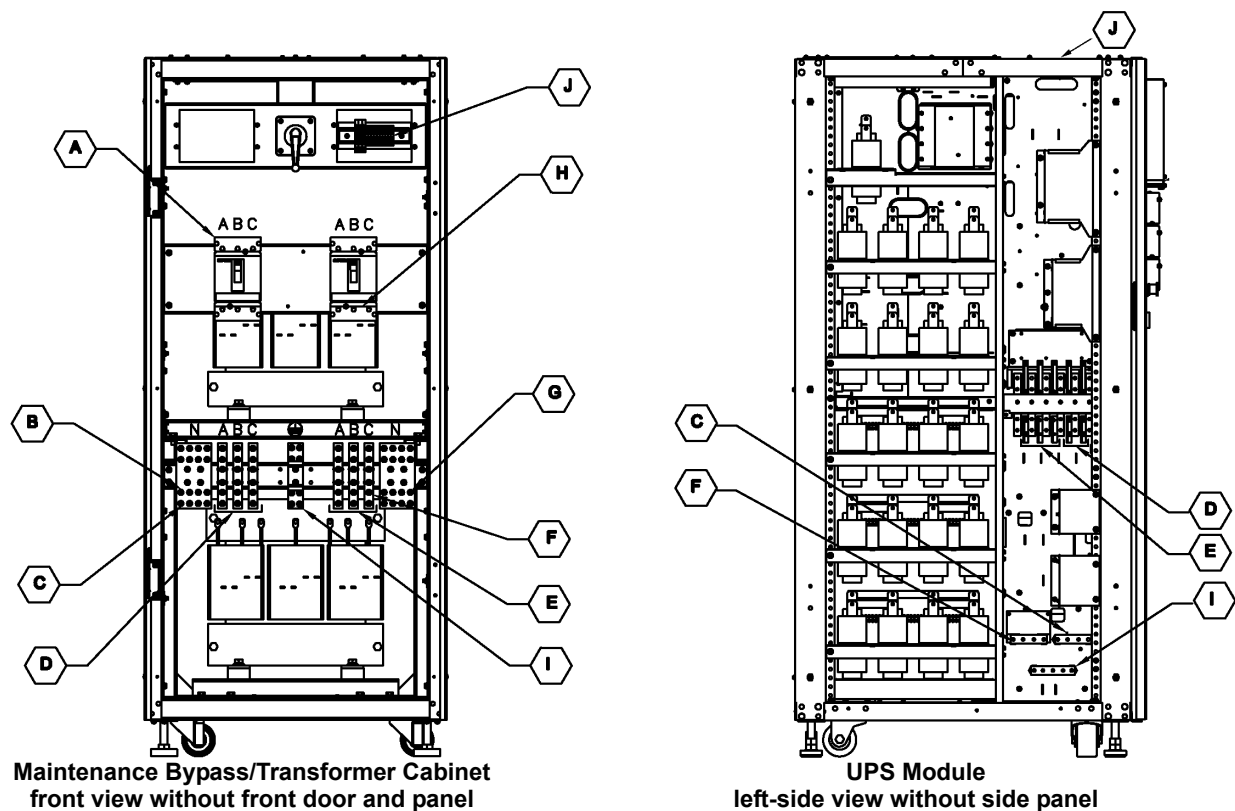

**NOTES**

1. All Liebert-supplied cable must be repositioned prior to and while the cabinets are being placed in their final installed location.
2. All interconnection hardware supplied by Liebert.
3. AC connections must be made to the UPS module before attaching maintenance bypass/transformer cabinet to UPS module.
4. Utility AC source neutral not required for maintenance bypass/transformer cabinet types D, E, M, N.
5. All cabling will be field-supplied when maintenance bypass/transformer cabinet is configured as stand-alone cabinet.
6. Maintenance bypass/transformer cabinets must attach to the left side only.
7. Refer to the individual drawing of each piece of equipment for additional details.

**Table 17 Liebert-supplied interconnect wiring for Maintenance Bypass Cabinet**

Run	From	To	Conductors
A	Utility AC source	Maintenance	Ph A, B, C bypass/ transformer cabinet
B	Utility AC source	Maintenance	Neutral bypass/ transformer cabinet
C	Maintenance	UPS module AC input	Neutral - UPS Input
D	Maintenance	UPS module AC input	Ph A, B, C - UPS Input
E	UPS module AC output	Maintenance	Ph A, B, C - UPS Output
F	UPS module AC output	Maintenance	Neutral - UPS Output
G	Maintenance	Load AC connection	Neutral bypass cabinet
H	Maintenance	Load AC connection	Ph A, B, C bypass cabinet
I	Utility AC source	All ground connections	Ground
J	Monitoring terminal block	UPS Parallel Logic Board (M3)	Bypass contacts

Figure 36 NX 1+1 parallel cabinet interconnections

1+1 Parallel Cabinet  
(Front View Without Front Door and Panel)

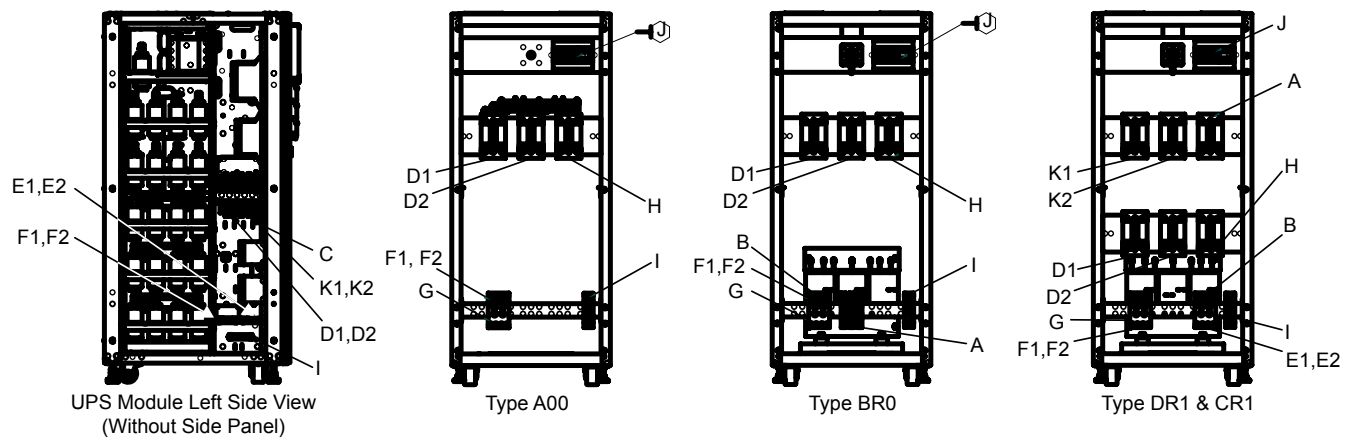

NOTES:

1. All Liebert-supplied cable will need to be repositioned prior to and while setting the cabinets in their installed location.
2. All interconnection cable and hardware supplied by others.
3. AC connections must be made to the UPS modules before attaching paralleling cabinet to UPS modules.
4. Utility AC source neutral not required for maintenance bypass/transformer cabinet type CR1.
5. Paralleling cabinets must be between both UPS modules.
6. Refer to the individual drawing of each piece of equipment for additional details

Table 18 Liebert-supplied interconnect wiring

Run	From	To	Conductors	Cabinet Type
A	Utility AC Source	Paralleling Cabinet	PH A, B, C - Bypass	BR0, CR1, DR1
B	Utility AC Source	Paralleling Cabinet	Neutral - Bypass	BR0, CR1, DR1
C	Utility AC Source	UPS Module AC Input	PH A,B,C - UPS	A00, BR0
D1	UPS #1 Module AC Output	Paralleling Cabinet	PH A, B, C - UPS	A00, BR0, CR1, DR1
D2	UPS #2 Module AC Output	Paralleling Cabinet	PH A, B, C - UPS	A00, BR0, CR1, DR1
E	Utility AC Source	UPS #1 Module AC Input	Neutral - UPS Input	A00, BR0, CR1, DR1
E2	Utility AC Source	UPS #1 Module AC Input	Neutral - UPS Input	A00, BR0, CR1, DR1
F1	Paralleling Cabinet	UPS #1 Module AC Output	Neutral - UPS Output	A00, BR0, CR1, DR1
F2	Paralleling Cabinet	UPS #1 Module AC Output	Neutral - UPS Output	A00, BR0, CR1, DR1
G	Paralleling Cabinet	Load AC Connection	Neutral - Load	A00, BR0, CR1, DR1
H	Paralleling Cabinet	Load AC Connection	PH A, B, C - Load	A00, BR0, CR1, DR1
I	Utility AC Source	All Ground Connections	Ground	A00, BR0, CR1, DR1
J	Monitoring Terminal Block	UPS Parallel Logic Board (M3)	Auxiliary Contacts	A00, BR0, CR1, DR1
K1	UPS #1 Module AC Input	Paralleling Cabinet	PH A, B, C - UPS	CR1, DR1
K2	UPS #1 Module AC INPUT	Paralleling Cabinet	PH A, B, C - UPS	CR1, DR1

Figure 37 Lineup detail—SlimLine distribution cabinet to NX

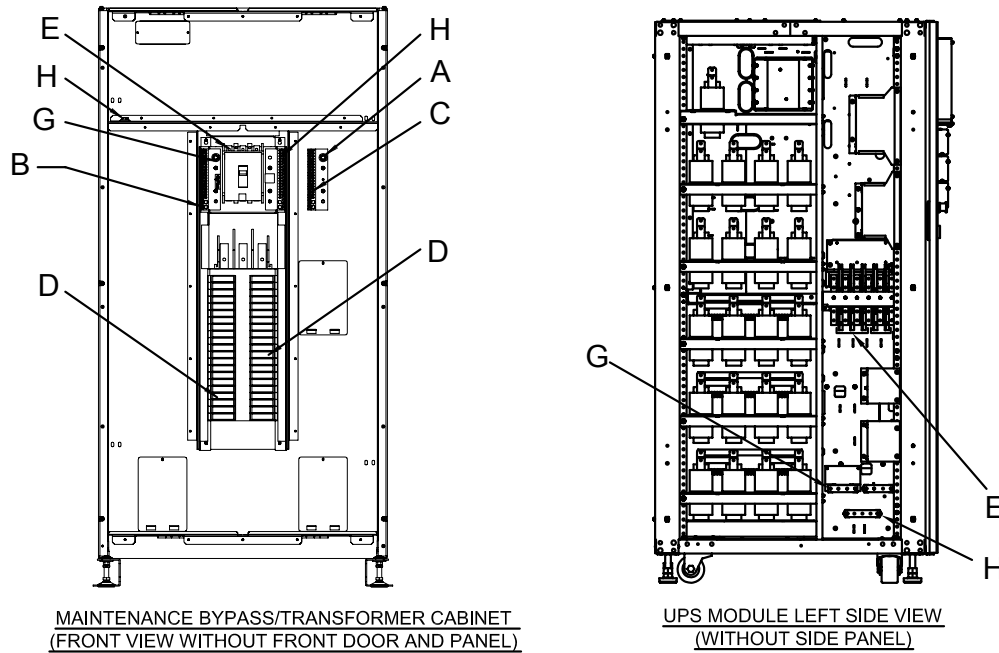

**NOTES:**

1. All Liebert-supplied cable will need to be repositioned prior to and while setting the cabinets in their installed location.
2. All interconnection cables and hardware supplied by Liebert.
3. AC connections must be made to the UPS module before attaching.
4. See **Figure 45** for placement of distribution cabinet.
5. Refer to the individual drawing of each piece of equipment for additional details.

**Table 19 Liebert-supplied interconnect wiring—SlimLine distribution cabinet to NX**

Run	From	To	Conductors
A	Distribution Cabinet	Load AC Connection	Isolated Ground
B	Distribution Cabinet	Load AC Connection	Neutral Distribution Cabinet
C	Distribution Cabinet	Load AC Connection	Ground Distribution Cabinet
D	Distribution Cabinet	Load AC Connection	PH A,B,C
E	UPS Module AC Output	Distribution Cabinet	PH A, B, C
G	UPS Module AC Output	Distribution Cabinet	Neutral
H	UPS Module AC Output	All Ground Connections	Ground



Figure 38 Lineup detail—1+N Type A connection to NX

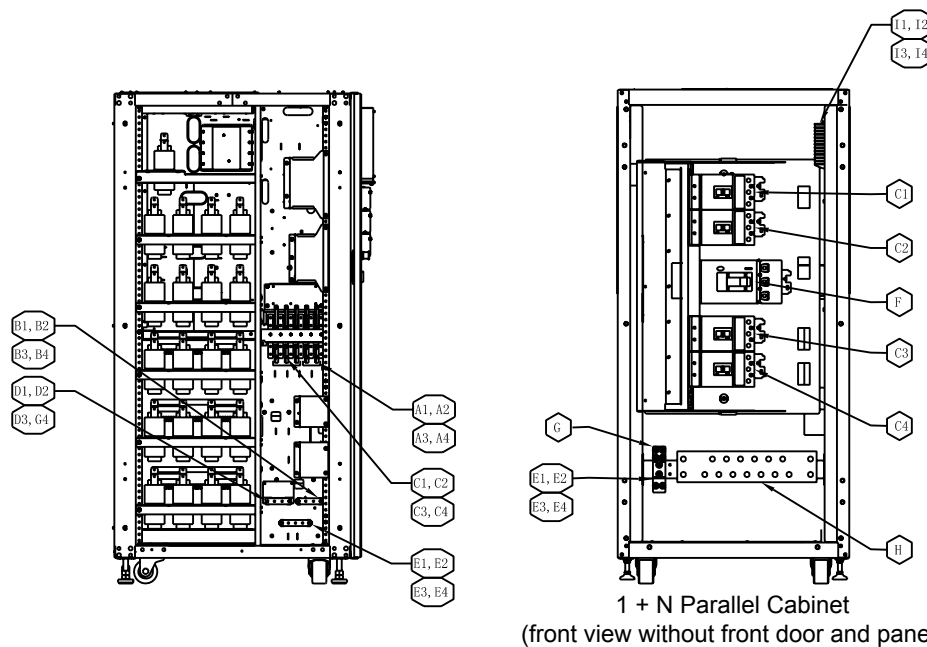

1. All Liebert-supplied cable must be repositioned prior to and while setting the cabinets in their installed location.
2. All interconnection cables and hardware supplied by others.
3. AC connections must be made to the UPS modules before attaching paralleling cabinet to UPS modules
4. The interconnecting output cables between the paralleling cabinet and the UPSes must be the same size and the same length.
5. The location of the system output neutral busbar (connection K) and the ground busbar (connections H, I and J) are shown for a left-access style. For right-access version, these busbars are at opposite locations
6. Refer to the individual drawing of each piece of equipment for additional details.

Table 20 Interconnect wiring—1+N Type A connection to NX

RUN	FROM	TO	CONDUCTORS
A1-A4	Utility AC Source	UPS #1-UPS #4 Module AC Input	Ph A, B, C - UPS Input
B1-B4	Utility AC Source	UPS #1-UPS #4 Module AC Input	Neutral - UPS Input
C1-C4	UPS #1-UPS #4 Module AC Output	Paralleling Cabinet	Ph A, B, C- UPS Output
D1-D4	UPS #1-UPS #4 Module AC Output	Paralleling Cabinet	Neutral - UPS Output
E1-E4	Paralleling Cabinet	UPS #1-UPS #4 Module AC Ground	Ground-UPS
F	Paralleling Cabinet	Load AC Connection	Ph A, B, C - Load
G	Paralleling Cabinet	Load AC Connection	Ground-Load
H	Paralleling Cabinet	Load AC Connection	Neutral-Load
I1-I4	Paralleling Cabinet	UPS #1-UPS #4 Module Parallel Logic Board (M3)	Output Breaker Aux Contact

Figure 39 Lineup detail—1+N Type A1 connection to NX

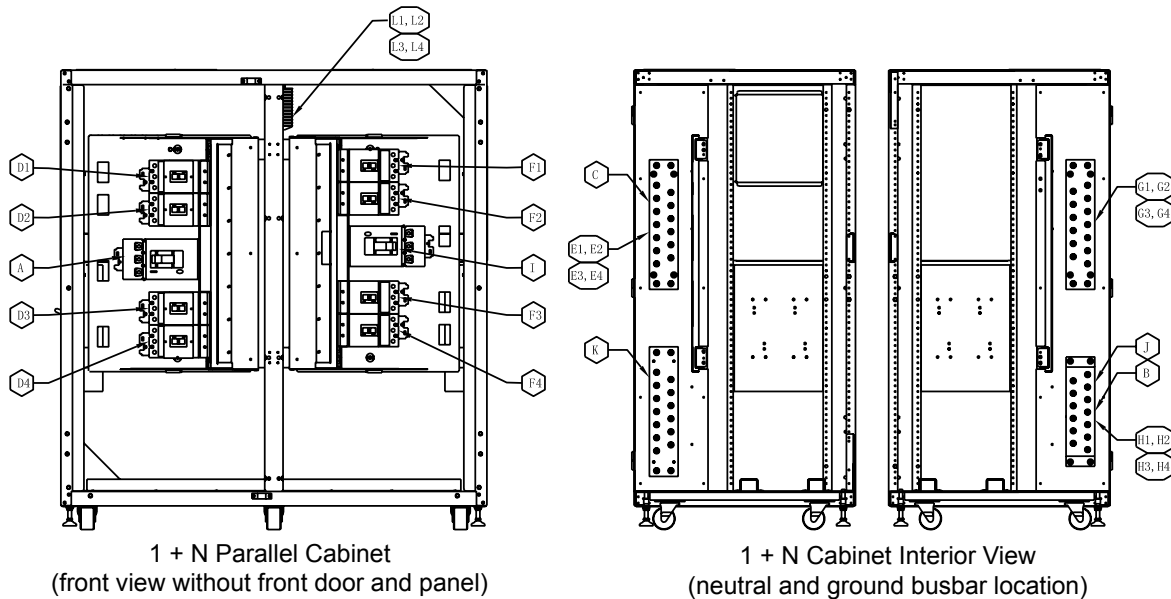

1. All Liebert-supplied cable must be repositioned prior to and while setting the cabinets in their installed location.
2. All interconnection cables and hardware supplied by others.
3. AC connections must be made to the UPS modules before attaching paralleling cabinet to UPS modules.
4. The interconnecting input cables between the paralleling cabinet and the UPSes must be the same size and the same length.
5. The interconnecting output cables between the paralleling cabinet and the UPSes must be the same size and the same length.
6. The location of the system output neutral busbar (connection K) and the ground busbar (connections H, I and J) are shown for a left-access style. For right-access version, these busbars are at opposite locations.
7. Refer to the individual drawing of each piece of equipment for additional details.

UPS Module Left Side View  
(without side panel)

Table 21 Interconnect wiring—1+N Type A1 connection to NX

Run	From	To	Conductors
A	Utility AC Source	Paralleling Cabinet	Ph A, B, C - System Input
B	Utility AC Source	Paralleling Cabinet	Ground - System Input
C	Utility AC Source	Paralleling Cabinet	Neutral - System Input
D1-D4	Paralleling Cabinet	UPS #1-UPS #4 Module AC Ground	Ph A, B, C - UPS Input
E1-E4	Paralleling Cabinet	UPS #1-UPS #4 Module AC Ground	Neutral - UPS Input
F1-F4	UPS #1-UPS #4 Module AC Output	Paralleling Cabinet	Ph A, B, C - UPS Output
G1-G4	UPS #1-UPS #4 Module AC Output	Paralleling Cabinet	Neutral - UPS Output
H1-H4	Paralleling Cabinet	UPS #1-UPS #4 Module AC Ground	Ground - UPS
I	Paralleling Cabinet	Load AC Connection	Ph A, B, C - Load
J	Paralleling Cabinet	Load AC Connection	Ground - Load
K	Paralleling Cabinet	Load AC Connection	Neutral - Load
L1-L4	Paralleling Cabinet	UPS #1-UPS #4 Module UPS Parallel Logic Board (M3)	Output Breaker Aux Contact

Figure 40 Lineup detail—1+N Type B connection to NX

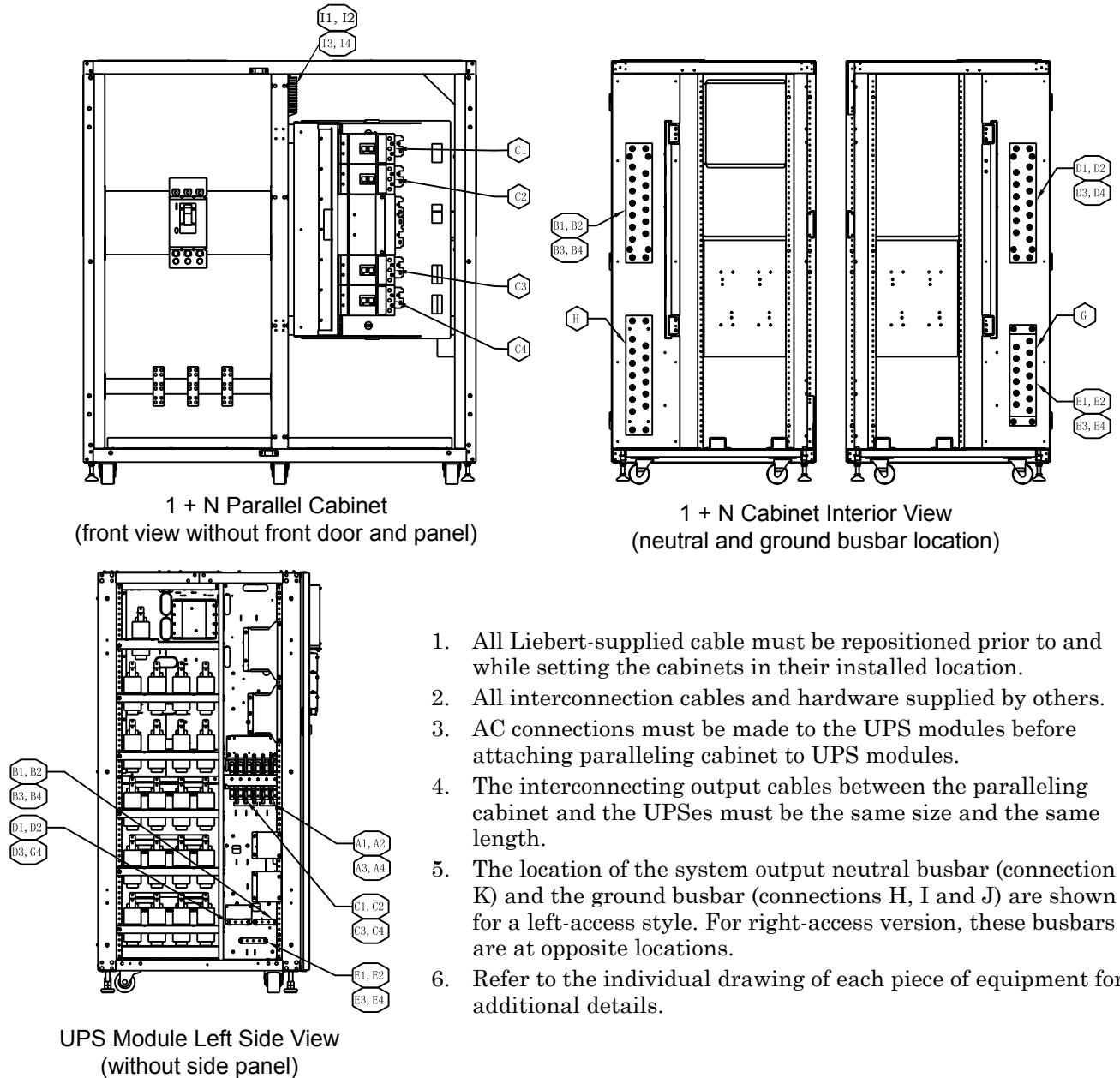

1. All Liebert-supplied cable must be repositioned prior to and while setting the cabinets in their installed location.
2. All interconnection cables and hardware supplied by others.
3. AC connections must be made to the UPS modules before attaching paralleling cabinet to UPS modules.
4. The interconnecting output cables between the paralleling cabinet and the UPSes must be the same size and the same length.
5. The location of the system output neutral busbar (connection K) and the ground busbar (connections H, I and J) are shown for a left-access style. For right-access version, these busbars are at opposite locations.
6. Refer to the individual drawing of each piece of equipment for additional details.

Table 22 Interconnect wiring—1+N Type B connection to NX

Run	From	To	Conductors
A1-A4	Utility AC Source	UPS #1-UPS #4 Module AC Input	Ph A, B, C - UPS Input
B1-B4	Utility AC Source	UPS #1-UPS #4 Module AC Input	Neutral - UPS Input
C1-C4	UPS #1-UPS #4 Module AC Output	Paralleling Cabinet	Ph A, B, C - UPS Output
D1-D4	UPS #1-UPS #4 Module AC Output	Paralleling Cabinet	Neutral - UPS Output
E1-E4	Paralleling Cabinet	UPS #1-UPS #4 Module AC Ground	Ground-UPS
F	Paralleling Cabinet	Load AC Connection	Ph A, B, C - Load
G	Paralleling Cabinet	Load AC Connection	Ground-load
H	Paralleling Cabinet	Load AC Connection	Neutral-load
I1-I4	Paralleling Cabinet	UPS #1-UPS #4 Module UPS Parallel Logic Board (M3)	Output Breaker Aux Contact

Figure 41 Lineup detail—1+N Type B1 connection to NX

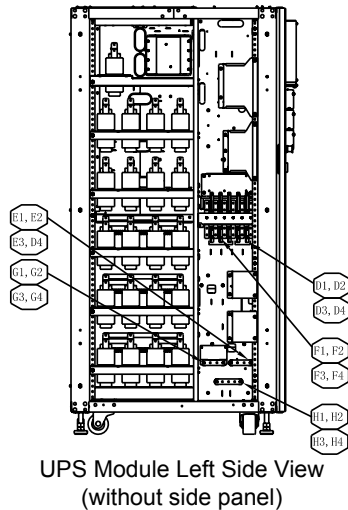
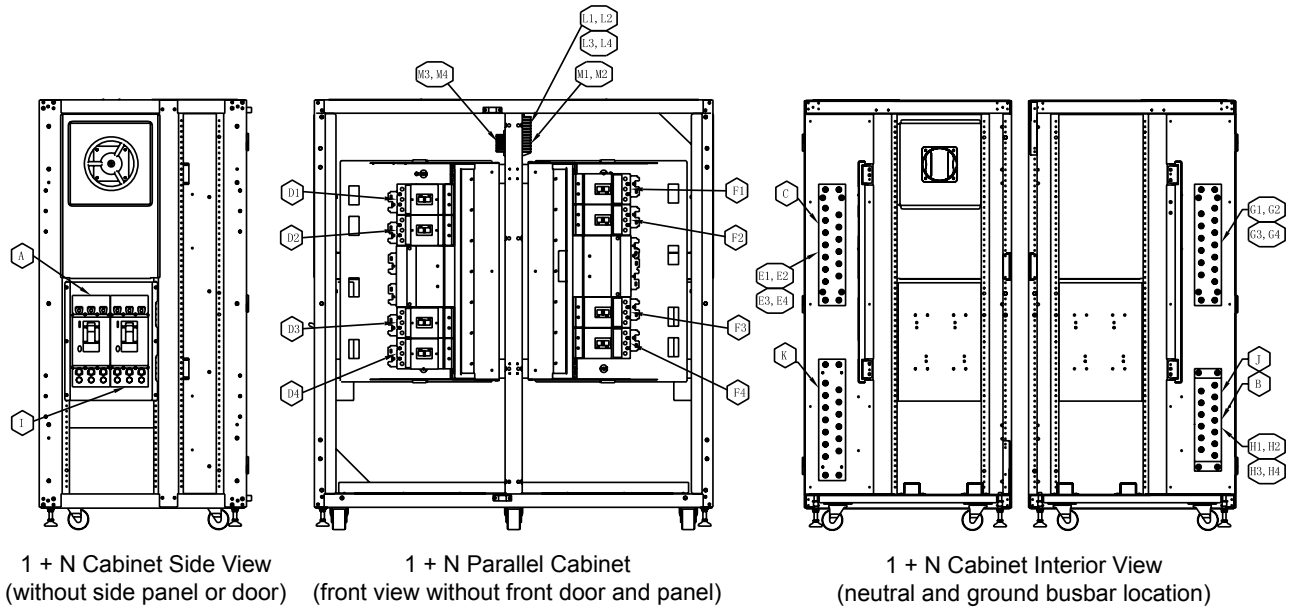

1. All Liebert-supplied cable must be repositioned prior to and while setting the cabinets in their installed location.
2. All interconnection cables and hardware supplied by others.
3. AC connections must be made to the UPS modules before attaching paralleling cabinet to UPS modules.
4. The interconnecting input cables between the paralleling cabinet and the UPSes must be the same size and the same length.
5. The interconnecting output cables between the paralleling cabinet and the UPSes must be the same size and the same length.
6. The location of the system output neutral busbar (connection K) and the ground busbar (connections H, I and J) are shown for a left-access style. For right-access version, these busbars are at opposite locations.
7. Refer to the individual drawing of each piece of equipment for additional details.

Table 23 Interconnect wiring—1+N Type B1 connection to NX

Run	From	To	Conductors
A	Utility AC Source	Paralleling Cabinet	Ph A, B, C - System Input
B	Utility AC Source	Paralleling Cabinet	Ground - System Input
C	Utility AC Source	Paralleling Cabinet	Neutral -system Input
D1-D4	Paralleling Cabinet	UPS #1-UPS #4 Module AC Input	Ph A, B, C - UPS Input
E1-E4	Paralleling Cabinet	UPS #1-UPS #4 Module AC Input	Neutral - UPS Input
F1-F4	UPS #1-UPS #4 Module AC Output	Paralleling Cabinet	Ph A, B, C - UPS Output
G1-G4	UPS #1-UPS #4 Module AC Output	Paralleling Cabinet	Neutral - UPS Output
H1-H4	Paralleling Cabinet	UPS #1-UPS #4 Module AC Ground	Ground-UPS
I	Paralleling Cabinet	Load AC Connection	Ph A, B, C - Load
J	Paralleling Cabinet	Load AC Connection	Ground-load
K	Paralleling Cabinet	Load AC Connection	Neutral-Load
L1-L4	Paralleling Cabinet	UPS #1-UPS #4 Module UPS Parallel Logic Board (M3)	Output Breaker Aux Contact
M1-M4	Paralleling Cabinet	UPS #1-UPS #4 Module UPS Parallel Logic Board (M3)	Rotary Switch Aux Contact

Figure 42 Lineup detail—1+N Type C connection to NX

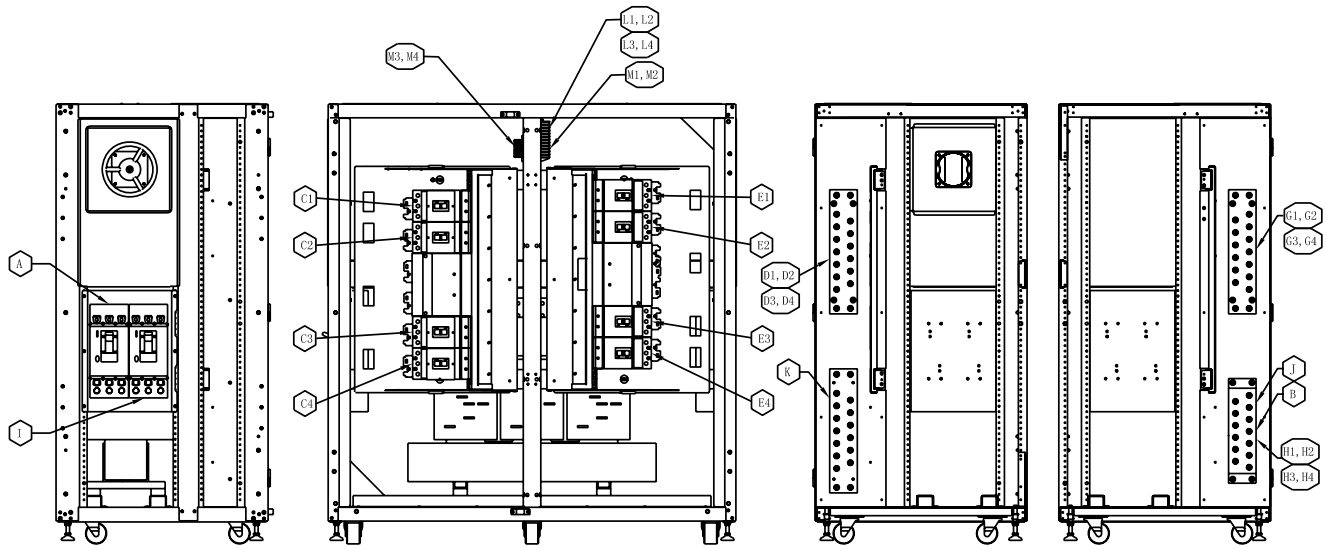

1 + N Cabinet Side View  
(without side panel or door)

1 + N Parallel Cabinet  
(front view without front door and panel)

1 + N Cabinet Interior View  
(neutral and ground busbar location)

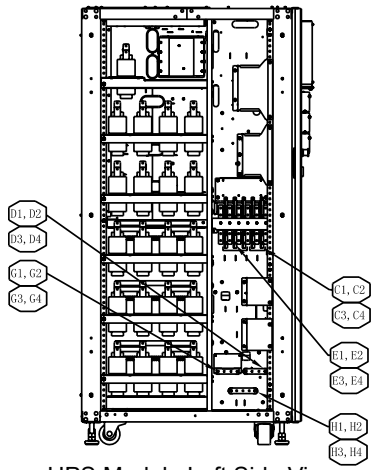

UPS Module Left Side View  
(without side panel)

1. All Liebert-supplied cable must be repositioned prior to and while setting the cabinets in their installed location.
2. All interconnection cables and hardware supplied by others.
3. AC connections must be made to the UPS modules before attaching paralleling cabinet to UPS modules.
4. Utility AC source neutral not required for maintenance bypass/transformer cabinet Type C.
5. The interconnecting input cables between the paralleling cabinet and the UPSes must be the same size and the same length.
6. The interconnecting output cables between the paralleling cabinet and the UPSes must be the same size and the same length.
7. The location of the system output neutral busbar (connection K) and the ground busbar (connections H, I and J) are shown for a left-access style. For right-access version, these busbars are at opposite locations.
8. Refer to the individual drawing of each piece of equipment for additional details.

Table 24 Interconnect wiring—1+N Type C connection to NX

Run	From	To	Conductors
A	Utility AC Source	Paralleling Cabinet	Ph A, B, C-system Input
B	Utility AC Source	Paralleling Cabinet	Ground - System Input
C1-C4	Paralleling Cabinet	UPS #1-UPS #4 Module AC Input	Ph A ,B, C - UPS Input
D1-d4	Paralleling Cabinet	UPS #1-UPS #4 Module AC Input	Neutral - UPS Input
E1-E4	UPS #1-UPS #4 Module AC Output	Paralleling Cabinet	Ph A, B, C - UPS Output
G1-G4	UPS #1-UPS #4 Module AC Output	Paralleling Cabinet	Neutral - UPS Output
H1-H4	Paralleling Cabinet	UPS #1-UPS #4 Module AC Ground	Ground - UPS
I	Paralleling Cabinet	Load AC Connection	Ph A ,B, C - Load
J	Paralleling Cabinet	Load AC Connection	Ground - Load
K	Paralleling Cabinet	Load AC Connection	Neutral - Load
L1-I4	Paralleling Cabinet	UPS #1-UPS #4 Module UPS Parallel Logic Board (M3)	Output Breaker Aux Contact
M1-M4	Paralleling Cabinet	UPS #1-UPS #4 Module UPS Parallel Logic Board (M3)	Rotary Switch Aux Contact

Figure 43 Lineup detail—1+N Type C1 connection to NX

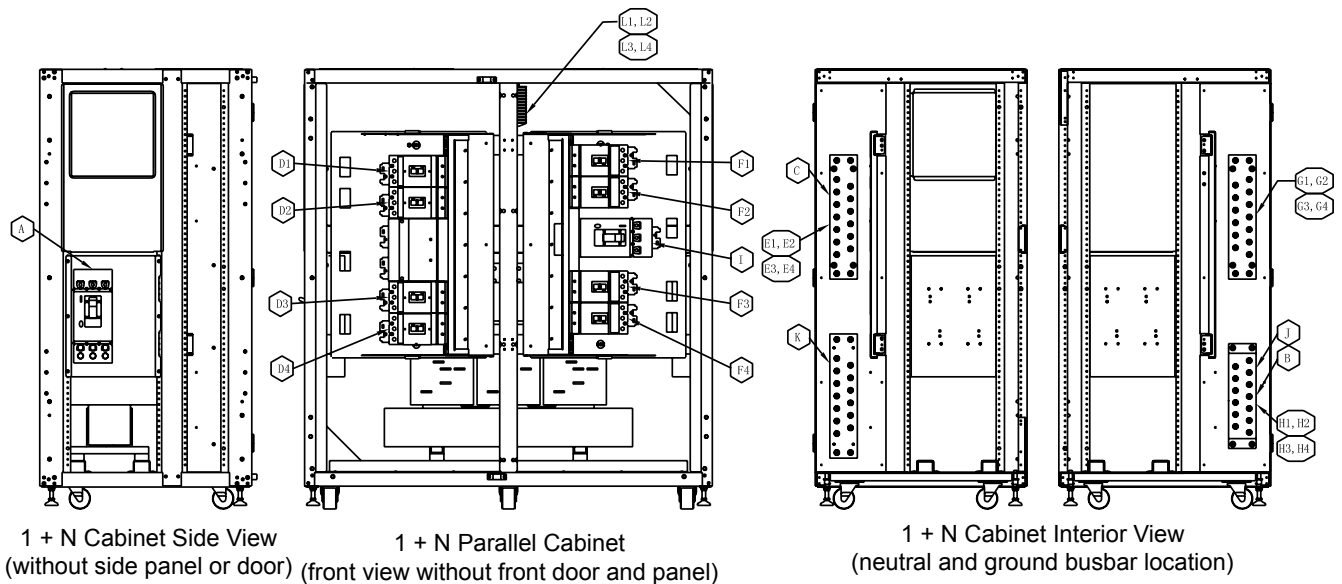

1 + N Cabinet Side View  
(without side panel or door)

1 + N Parallel Cabinet  
(front view without front door and panel)

1 + N Cabinet Interior View  
(neutral and ground busbar location)

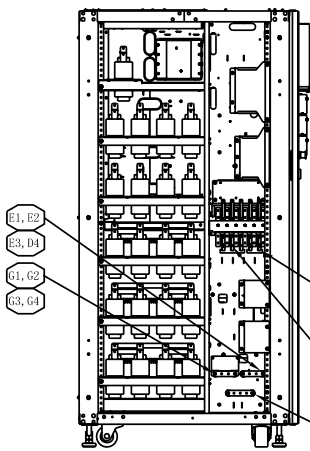

UPS Module Left Side View  
(without side panel)

1. All Liebert-supplied cable must be repositioned prior to and while setting the cabinets in their installed location.
2. All interconnection cables and hardware supplied by others.
3. AC connections must be made to the UPS modules before attaching paralleling cabinet to UPS modules.
4. The interconnecting input cables between the paralleling cabinet and the UPSes must be the same size and the same length.
5. The interconnecting output cables between the paralleling cabinet and the UPSes must be the same size and the same length.
6. The location of the system output neutral busbar (connection K) and the ground busbar (connections H, I and J) are shown for a left-access style. For right-access version, these busbars are at opposite locations.
7. Refer to the individual drawing of each piece of equipment for additional details.

Table 25 Interconnect wiring—1+N Type C1 connection to NX

Run	From	To	Conductors
A	Utility AC Source	Paralleling Cabinet	Ph A, B, C - System Input
B	Utility AC Source	Paralleling Cabinet	Ground - System Input
C	Utility AC Source	Paralleling Cabinet	Neutral -System Input
D1-D4	Paralleling Cabinet	UPS #1-UPS #4 Module AC Input	Ph A, B, C - UPS Input
E1-E4	Paralleling Cabinet	UPS #1-UPS #4 Module AC Input	Neutral - UPS Input
F1-F4	UPS #1-UPS #4 Module AC Output	Paralleling Cabinet	Ph A, B, C - UPS Output
G1-G4	UPS #1-UPS #4 Module AC Output	Paralleling Cabinet	Neutral - UPS Output
H1-H4	Paralleling Cabinet	UPS #1-UPS #4 Module AC Ground	Ground-UPS
I	Paralleling Cabinet	Load AC Connection	Ph A, B, C - Load
J	Paralleling Cabinet	Load AC Connection	Ground-Load
K	Paralleling Cabinet	Load AC Connection	Neutral- Load
L1-L4	Paralleling Cabinet	UPS #1-UPS #4 Module UPS Parallel Logic Board (M3)	Output Breaker Aux Contact

Figure 44 Lineup detail—1+N Type D connection to NX

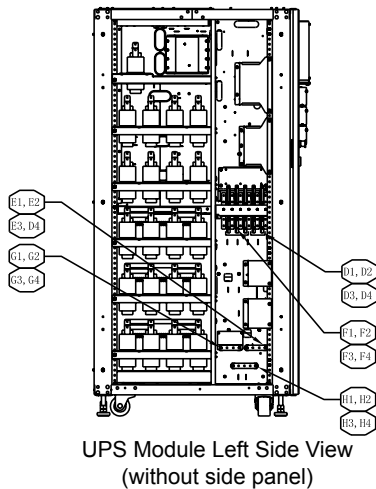
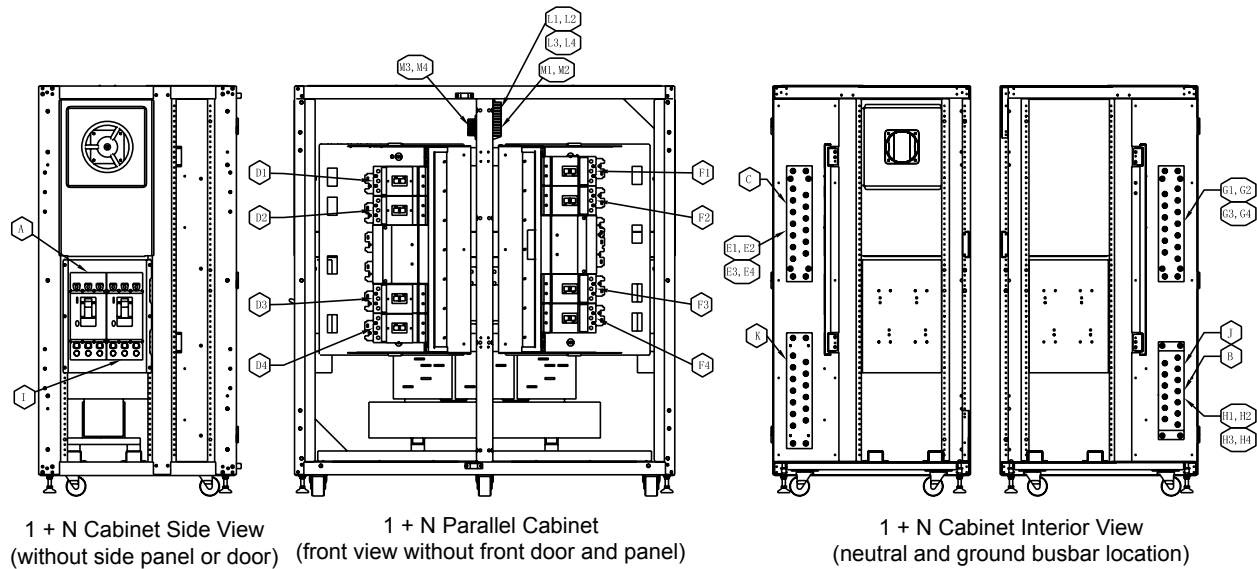

1. All Liebert-supplied cable must be repositioned prior to and while setting the cabinets in their installed location.
2. All interconnection cables and hardware supplied by others.
3. AC connections must be made to the UPS modules before attaching paralleling cabinet to the UPS modules.
4. The interconnecting input cables between the paralleling cabinet and the UPSes must be the same size and the same length.
5. The interconnecting output cables between the paralleling cabinet and the UPSes must be the same size and the same length
6. The location of the system output neutral busbar (connection K) and the ground busbar (connections H, I and J) are shown for a left-access style. For right-access version, these busbars are at opposite locations.
7. Refer to the individual drawing of each piece of equipment for additional details.

Table 26 Interconnect wiring—1+N Type D connection to NX

Run	From	To	Conductors
A	Utility AC Source	Paralleling Cabinet	Ph A, B, C - System Input
B	Utility AC Source	Paralleling Cabinet	Ground - System Input
C	Utility AC Source	Paralleling Cabinet	Neutral - System Input
D1-D4	Paralleling Cabinet	UPS #1-UPS #4 Module AC Input	Ph A, B, C - UPS Input
E1-E4	Paralleling Cabinet	UPS #1-UPS #4 Module AC Input	Neutral - UPS Input
F1-F4	UPS #1-UPS #4 Module AC Output	Paralleling Cabinet	Ph A, B, C - UPS Output
G1-G4	UPS #1-UPS #4 Module AC Output	Paralleling Cabinet	Neutral - UPS Output
H1-H4	Paralleling Cabinet	UPS #1-UPS #4 Module AC Ground	Ground - UPS
I	Paralleling Cabinet	Load AC Connection	Ph A, B, C - Load
J	Paralleling Cabinet	Load AC Connection	Ground - Load
K	Paralleling Cabinet	Load AC Connection	Neutral - Load
L1-L4	Paralleling Cabinet	UPS #1-UPS #4 Module UPS Parallel Logic Board (M3)	Output Breaker Aux Contact
M1-M4	Paralleling Cabinet	UPS #1-UPS #4 Module UPS Parallel Logic Board (M3)	Rotary Switch Aux Contact

Figure 45 SlimLine locations

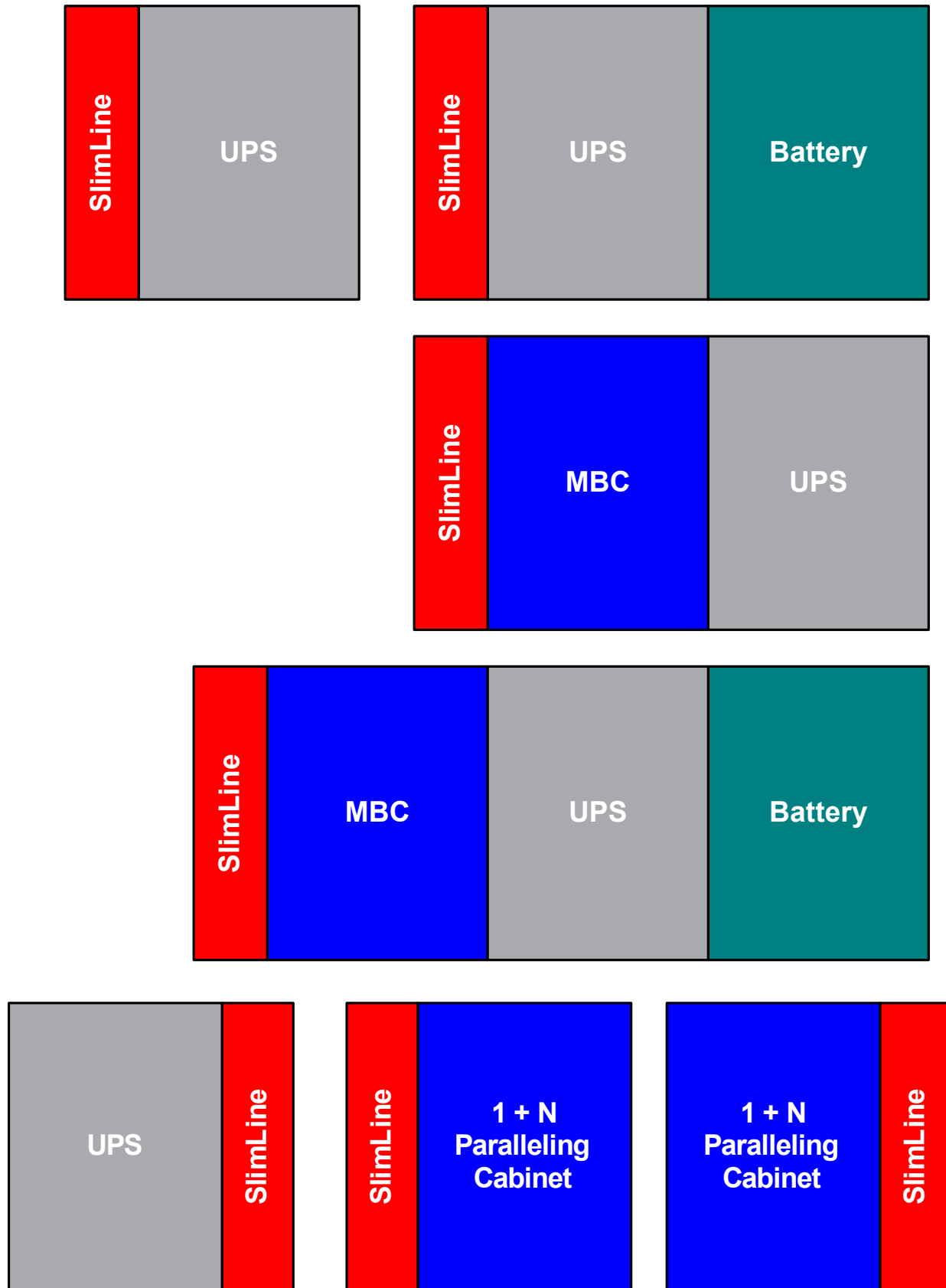



## 8.0 SPECIFICATIONS AND TECHNICAL DATA

### 8.1 Lug Size and Torque Requirements

Use commercially available solderless lugs for the wire size required for your application. Refer to **Table 27**. Connect wire to the lug using tools and procedures specified by the lug manufacturer.

**Table 27 Torque specifications**

<b>Nut and Bolt Combinations</b>				
<b>Bolt Shaft Size</b>	<b>Grade 2 Standard</b>		<b>Electrical Connections with Belleville Washers</b>	
	<b>Lb-in</b>	<b>N-m</b>	<b>Lb-in</b>	<b>N-m</b>
1/4	53	6.0	46	5.2
5/16	107	12	60	6.8
3/8	192	22	95	11
1/2	428	22	256	29

<b>Circuit Breakers With Compression Lugs (For Power Wiring)</b>		
<b>Wire Size or Range</b>	<b>Lb-in</b>	<b>N-m</b>
#6 - #4	100	11
#3 - #1	125	14
1/0 - 2/0	150	17
3/0 - 200 MCM	200	23
250 - 400 MCM	250	28
500 - 700 MCM	300	34

<b>Circuit Breakers With Compression Lugs (For Power Wiring)</b>		
<b>Current Rating</b>	<b>Lb-in</b>	<b>N-m</b>
400 - 1200 Amps	300.00	34.00

<b>Terminal Block Compression Lugs (For Control Wiring)</b>		
<b>AWG Wire Size or Range</b>	<b>Lb-in</b>	<b>N-m</b>
#22 - #14	3.5 to 5.3	0.4 to 0.6

**NOTE:** Use the values in this table unless the equipment is labeled with a different torque value.

**Table 28 Battery torque rating**

<b>Battery</b>	<b>Initial Torque in-lb (N-m)</b>	<b>Annual Torque in-lb (N-m)</b>
UPS12-100MR	40 (4.5)	32 (3.48)
UPS12-140MR	40 (4.5)	32 (3.48)
UPS12-200MR	40 (4.5)	32 (3.48)
UPS12-270MR	40 (4.5)	32 (3.48)
UPS12-310MR	65 (7.4)	52 (5.88)
UPS12-370MR	65 (7.4)	52 (5.88)
UPS12-475MR	110 (12.4)	110 (12.4)

**Table 29 Maintenance bypass cabinet electrical data (single input)**

kVA	Type	Maintenance Bypass I/P Voltage (VAC)	Bypass Cabinet Max Input Current	Cabinet Input OCP CB Size (A)	O/P Voltage (VAC)	Nominal O/P Current Rating (A)	Output OCP CB Size (A)
30	A, J	208	104	125	208	83	125
30	B, K	480	47	60	208	83	125
30	B, K	600	37	50	208	83	125
30	B, K	220	101	125	208	83	125
30	C, L	480	48	60	480	36	50
30	C, L	600	38	50	600	29	40
30	C, L	220	105	125	220	79	100
30	D, M	480	47	60	208	83	125
30	D, M	600	38	50	208	83	125
30	D, M	208	108	150	208	83	125
30	D, M	220	103	125	208	83	125
30	D, M	240	93	125	208	83	125
30	E, N	480	48	60	480	36	50
30	E, N	600	39	50	600	29	40
30	E, N	220	106	125	220	79	100
20	A, J	208	69	90	208	56	70
20	B, K	480	31	40	208	56	70
20	B, K	600	25	30	208	56	70
20	B, K	220	68	90	208	56	70
20	C, L	480	32	40	480	24	30
20	C, L	600	26	40	600	19	30
20	C, L	220	70	90	220	52	70
20	D, M	480	31	40	208	56	70
20	D, M	600	25	40	208	56	70
20	D, M	208	72	90	208	56	70
20	D, M	220	68	90	208	56	70
20	D, M	240	62	80	208	56	70
20	E, N	480	32	40	480	24	30
20	E, N	600	26	40	600	19	30
20	E, N	220	70	90	220	52	70
15	A, J	208	52	70	208	42	60
15	B, K	480	23	30	208	42	60
15	B, K	600	19	30	208	42	60
15	B, K	220	51	70	208	42	60
15	C, L	480	24	30	480	18	30
15	C, L	600	19	30	600	14	20
15	C, L	220	52	70	220	39	50
15	D, M	480	23	30	208	42	60
15	D, M	600	19	30	208	42	60
15	D, M	208	54	70	208	42	60
15	D, M	220	51	70	208	42	60

**Table 29 Maintenance bypass cabinet electrical data (single input) (continued)**

kVA	Type	Maintenance Bypass I/P Voltage (VAC)	Bypass Cabinet Max Input Current	Cabinet Input OCP CB Size (A)	O/P Voltage (VAC)	Nominal O/P Current Rating (A)	Output OCP CB Size (A)
15	D, M	240	47	60	208	42	60
15	E, N	480	24	30	480	18	30
15	E, N	600	19	30	600	14	20
15	E, N	220	53	70	220	39	50
10	A, J	208	35	50	208	28	40
10	B, K	480	16	20	208	28	40
10	B, K	600	12	15	208	28	40
10	B, K	220	34	50	208	28	40
10	C, L	480	16	20	480	12	15
10	C, L	600	13	20	600	10	15
10	C, L	220	35	50	220	26	40
10	D, M	480	16	20	208	28	40
10	D, M	600	13	15	208	28	40
10	D, M	208	36	50	208	28	40
10	D, M	220	34	50	208	28	40
10	D, M	240	32	40	208	28	40
10	E, N	480	16	20	480	12	15
10	E, N	600	13	20	600	10	15
10	E, N	220	35	50	220	26	40

**Table 30 Maintenance bypass cabinet electrical data (dual input)**

kVA	Type	System I/P Voltage (VAC)	Rectifier Max Input Current	Rectifier Input OCP CB Size (A)	Bypass Max Input Current	Bypass Input OCP CB Size (A)	O/P Voltage (VAC)	Nominal O/P Current Rating (A)	Output OCP CB Size (A)
30	F, P	480	42	50	47	50	208	83	125
30	F, P	600	33	40	37	40	208	83	125
30	F, P	208	95	125	107	125	208	83	125
30	F, P	220	90	125	101	125	208	83	125
30	F, P	240	83	100	93	100	208	83	125
20	F, P	480	28	40	31	40	208	55	70
20	F, P	600	22	30	25	30	208	56	70
20	F, P	208	64	80	71.5	80	208	56	70
20	F, P	220	61	80	68	70	208	56	70
20	F, P	240	56	70	62	70	208	56	70

**Table 30 Maintenance bypass cabinet electrical data (dual input)**

kVA	Type	System I/P Voltage (VAC)	Rectifier Max Input Current	Rectifier Input OCP CB Size (A)	Bypass Max Input Current	Bypass Input OCP CB Size (A)	O/P Voltage (VAC)	Nominal O/P Current Rating (A)	Output OCP CB Size (A)
15	F, P	480	21	30	24	30	208	42	60
15	F, P	600	17	30	19	20	208	42	60
15	F, P	208	49	60	54	60	208	42	60
15	F, P	220	46	60	51	60	208	42	60
15	F, P	240	42	60	47	50	208	42	60
10	F, P	480	14	20	16	20	208	28	40
10	F, P	600	12	15	13	15	208	28	40
10	F, P	208	33	40	36	40	208	28	40
10	F, P	220	31	40	34	40	208	28	40
10	F, P	240	29	40	32	40	208	28	40

**Table 31 Multi-module bypass cabinet electrical data**

System Size	Type	kVA	System I/P Voltage (VAC)	System Max Input Current	System Input OCP CB Size (A)	O/P Voltage (VAC)	Nominal O/P Current Rating (A)	Output OCP CB Size (A)
1+1	A00, BR0	30	208	104	125	208	83	125
		20	208	70	90	208	56	70
		15	208	53	70	208	42	60
		10	208	35	45	208	28	40
	CR1	30	208	107	150A	208	83	125
	CR1, DR1	30	220	101	150A	208	83	125
	CR1, DR1	30	480	46	70A	208	83	125
	CR1, DR1	30	600	37	60A	208	83	125
	CR1	20	208	71	100A	208	56	70
	CR1, DR1	20	220	68	100A	208	56	70
	CR1, DR1	20	480	31	50A	208	56	70
	CR1, DR1	20	600	25	40A	208	56	70
	CR1	15	208	54	80A	208	42	60
	CR1, DR1	15	220	51	80A	208	42	60
	CR1, DR1	15	480	23	40A	208	42	60
	CR1, DR1	15	600	19	30A	208	42	60
	CR1	10	208	36	60A	208	28	40
	CR1, DR1	10	220	34	50A	208	28	40
CR1, DR1	10	480	16	30A	208	28	40	
CR1, DR1	10	600	12	20A	208	28	40	

**Table 31 Multi-module bypass cabinet electrical data (continued)**

System Size	Type	kVA	System I/P Voltage (VAC)	System Max Input Current	System Input OCP CB Size (A)	O/P Voltage (VAC)	Nominal O/P Current Rating (A)	Output OCP CB Size (A)
2+0	A00, BR0	30	208	104	125	208	167	225
		20	208	70	90	208	111	150
		15	208	53	70	208	83	125
		10	208	35	45	208	56	70
	CR1	30	208	73	100A	208	167	225
	CR1, DR1	30	220	69	100A	208	167	225
	CR1, DR1	30	480	32	50A	208	167	225
	CR1, DR1	30	600	25	40A	208	167	225
	CR1	20	208	110	150A	208	111	150
	CR1, DR1	20	220	104	150A	208	111	150
	CR1, DR1	20	480	48	70A	208	111	150
	CR1, DR1	20	600	38	50A	208	111	150
	CR1	15	208	146	200A	208	83	125
	CR1, DR1	15	220	138	200A	208	83	125
	CR1, DR1	15	480	63	80A	208	83	125
	CR1, DR1	15	600	51	70A	208	83	125
	CR1	10	208	219	300A	208	56	70
	CR1, DR1	10	220	207	300A	208	56	70
	CR1, DR1	10	480	95	125A	208	56	70
	CR1, DR1	10	600	76	100A	208	56	70
SR0, W00	30	208	210	300	208	167	225	
	20	208	140	200	208	111	150	
	15	208	105	150	208	83	125	
	10	208	70	100	208	56	70	

**Table 31 Multi-module bypass cabinet electrical data (continued)**

System Size	Type	kVA	System I/P Voltage (VAC)	System Max Input Current	System Input OCP CB Size (A)	O/P Voltage (VAC)	Nominal O/P Current Rating (A)	Output OCP CB Size (A)
2+1	E00, FR0	30	208	104	125	208	167	225
		20	208	70	90	208	111	150
		15	208	53	70	208	83	125
		10	208	35	45	208	56	70
	G01, GR1	10	208	73	100	208	56	70
		10	220	69	100	208	56	70
		10	480	32	50	208	56	70
		10	600	25	40	208	56	70
		15	208	110	150	208	83	125
		15	220	104	150	208	83	125
		15	480	47	70	208	83	125
		15	600	38	50	208	83	125
		20	208	146	200	208	111	150
		20	220	138	200	208	111	150
		20	480	63	100	208	111	150
		20	600	51	70	208	111	150
		30	208	219	300	208	167	225
		30	220	207	300	208	167	225
		30	480	95	125	208	167	225
		30	600	76	100	208	167	225
	HR1	10	220	68	100	208	56	70
		10	480	31	50	208	56	70
		10	600	25	40	208	56	70
		15	220	102	150	208	83	125
		15	480	47	70	208	83	125
		15	600	38	50	208	83	125
		20	220	137	200	208	111	150
		20	480	63	100	208	111	150
		20	600	50	70	208	111	150
		30	220	205	300	208	167	225
		30	480	94	125	208	167	225
	TR0, X00	30	208	210	300	208	167	225
		20	208	140	200	208	111	150
		15	208	105	150	208	83	125
		10	208	70	100	208	56	70

**Table 31 Multi-module bypass cabinet electrical data (continued)**

System Size	Type	kVA	System I/P Voltage (VAC)	System Max Input Current	System Input OCP CB Size (A)	O/P Voltage (VAC)	Nominal O/P Current Rating (A)	Output OCP CB Size (A)
3+0	E00, FR0	30	208	104	125	208	250	400
		20	208	70	90	208	167	225
		15	208	53	70	208	125	200
		10	208	35	45	208	83	125
	G01, GR1	10	208	110	150	208	83	125
		10	220	104	150	208	83	125
		10	480	47	60	208	83	125
		10	600	38	50	208	83	125
		15	208	164	225	208	125	200
		15	220	155	200	208	125	200
		15	480	71	90	208	125	200
		15	600	57	80	208	125	200
		20	208	219	300	208	167	225
		20	220	207	300	208	167	225
		20	480	95	125	208	167	225
		20	600	76	100	208	167	225
		30	208	329	500	208	250	400
		30	220	311	400	208	250	400
		30	480	142	200	208	250	400
		30	600	114	150	208	250	400
	HR1	10	220	102	150	208	83	125
		10	480	47	60	208	83	125
		10	600	38	50	208	83	125
		15	220	154	200	208	125	200
		15	480	70	90	208	125	200
		15	600	56	80	208	125	200
		20	220	205	300	208	167	225
		20	480	94	125	208	167	225
		20	600	75	100	208	167	225
		30	220	307	400	208	250	400
		30	480	141	200	208	250	400
	TR0, X00	30	208	315	400	208	250	400
		20	208	210	300	208	167	225
		15	208	158	200	208	125	200
		10	208	105	150	208	83	125

**Table 31 Multi-module bypass cabinet electrical data (continued)**

System Size	Type	kVA	System I/P Voltage (VAC)	System Max Input Current	System Input OCP CB Size (A)	O/P Voltage (VAC)	Nominal O/P Current Rating (A)	Output OCP CB Size (A)
3+1	J00, KR0	30	208	104	125	208	250	400
		20	208	70	90	208	167	225
		15	208	53	70	208	125	200
		10	208	35	45	208	83	125
	LR1	10	208	110	150	208	83	125
		10	220	104	150	208	83	125
		10	480	47	60	208	83	125
		10	600	38	50	208	83	125
		15	208	164	225	208	125	200
		15	220	155	200	208	125	200
		15	480	71	90	208	125	200
		15	600	57	80	208	125	200
		20	208	219	300	208	167	225
		20	220	207	300	208	167	225
		20	480	95	125	208	167	225
		20	600	76	100	208	167	225
		30	208	329	500	208	250	400
		30	220	311	400	208	250	400
		30	480	142	200	208	250	400
		30	600	114	150	208	250	400
	MR1	10	220	102	150	208	83	125
		10	480	47	60	208	83	125
		10	600	38	50	208	83	125
		15	220	154	200	208	125	200
		15	480	70	90	208	125	200
		15	600	56	80	208	125	200
		20	220	205	300	208	167	225
		20	480	94	125	208	167	225
		20	600	75	100	208	167	225
		30	220	307	400	208	250	400
		30	480	141	200	208	250	400
	UR0, Y00	30	208	315	400	208	250	400
		20	208	210	300	208	167	225
		15	208	158	200	208	125	200
10		208	105	150	208	83	125	



**Table 31 Multi-module bypass cabinet electrical data (continued)**

System Size	Type	kVA	System I/P Voltage (VAC)	System Max Input Current	System Input OCP CB Size (A)	O/P Voltage (VAC)	Nominal O/P Current Rating (A)	Output OCP CB Size (A)
4+0	J00, KR0	30	208	104	125	208	333	500
		20	208	70	90	208	222	300
		15	208	53	70	208	167	225
		10	208	35	45	208	111	150
	LR1	10	208	146	175	208	111	150
		10	220	138	175	208	111	150
		10	480	63	80	208	111	150
		10	600	51	70	208	111	150
		15	208	219	300	208	167	225
		15	220	207	250	208	167	225
		15	480	95	125	208	167	225
		15	600	76	100	208	167	225
		20	208	292	400	208	222	300
		20	220	276	400	208	222	300
		20	480	127	175	208	222	300
		20	600	101	125	208	222	300
		30	208	438	600	208	333	500
		30	220	414	500	208	333	500
		30	480	190	250	208	333	500
		30	600	152	200	208	333	500
	MR1	10	220	137	175	208	111	150
		10	480	63	80	208	111	150
		10	600	50	60	208	111	150
		15	220	205	250	208	167	225
		15	480	94	125	208	167	225
		15	600	75	90	208	167	225
		20	220	273	400	208	222	300
		20	480	125	150	208	222	300
		20	600	100	125	208	222	300
		30	220	410	500	208	333	500
		30	480	188	225	208	333	500
	UR0, Y00	30	208	421	500	208	333	500
		20	208	280	400	208	222	300
		15	208	210	250	208	167	225
		10	208	140	175	208	111	150

**Table 32 Maintenance bypass cabinet lug sizes**

**Input**

Unit Rating	Nominal System Input Voltage	Bolt Size	Maximum Recommended Lug	
			Lug T&B One Hole 54000	Lug T&B One Hole REDDY
30	600	6M (1/4")	54105	62204
30	480	6M (1/4")	54106	62204
30	240	6M (1/4")	54152	62205
30	220	6M (1/4")	54152	62205
30	208	6M (1/4")	54152	62205
20	600	6M (1/4")	NA	62204
20	480	6M (1/4")	54130	62204
20	240	6M (1/4")	54107	62204
20	220	6M (1/4")	54107	62204
20	208	6M (1/4")	54107	62204
15	600	6M (1/4")	NA	62204
15	480	6M (1/4")	NA	62204
15	240	6M (1/4")	54106	62204
15	220	6M (1/4")	54106	62204
15	208	6M (1/4")	54106	62204
10	600	6M (1/4")	NA	62204
10	480	6M (1/4")	NA	62204
10	240	6M (1/4")	54130	62204
10	220	6M (1/4")	54130	62204
10	208	6M (1/4")	54130	62204

**Table 32 Maintenance bypass cabinet lug sizes (continued)**

Output				
Unit Rating	Nominal System Output Voltage	Bolt Size	Maximum Recommended Lug	
			Lug T&B One Hole 54000	Lug T&B One Hole REDDY
30	600	6M (1/4")	54130	62204
30	480	6M (1/4")	54106	62204
30	240	6M (1/4")	54108	62205
30	220	6M (1/4")	54108	62205
30	208	6M (1/4")	54108	62205
20	600	6M (1/4")	NA	62204
20	480	6M (1/4")	54130	62204
20	240	6M (1/4")	54106	62204
20	220	6M (1/4")	54106	62204
20	208	6M (1/4")	54106	62204
15	600	6M (1/4")	NA	62204
15	480	6M (1/4")	NA	62204
15	240	6M (1/4")	54106	62204
15	220	6M (1/4")	54106	62204
15	208	6M (1/4")	54106	62204
10	600	6M (1/4")	NA	62204
10	480	6M (1/4")	NA	62204
10	240	6M (1/4")	54130	62204
10	220	6M (1/4")	54130	62204
10	208	6M (1/4")	54130	62204

**Table 33 Battery cabinet physical characteristics**

Battery Cabinet Type	Dimensions WxDxH in. (mm)	Net Weight Without Batteries, lb. (kg)
Short Narrow	27.2x31.4x63 (690x825x1600)	551 (250)
Short Wide	58.5x31.4x63 (1488x825x1600)	889 (400)

**Table 34 Maintenance Bypass Cabinet weights**

UPS Rating	Maintenance Bypass Cabinet Style, lb. (kg)											
	A	B	C	D	E	F	J	K	L	M	N	P
10kVA	408 (185)	545 (247)	675 (306)	602 (273)	732 (332)	630 (286)	403 (183)	540 (245)	670 (304)	597 (271)	728 (330)	630 (286)
15kVA	408 (185)	567 (257)	728 (330)	659 (299)	822 (373)	680 (308)	403 (183)	562 (255)	723 (328)	655 (297)	818 (371)	680 (308)
20kVA	408 (185)	646 (293)	842 (382)	739 (335)	935 (424)	750 (340)	403 (183)	642 (291)	838 (380)	734 (333)	930 (422)	750 (340)
30kVA	408 (185)	694 (315)	893 (405)	807 (366)	1027 (466)	840 (381)	403 (183)	690 (313)	888 (403)	802 (364)	1023 (464)	840 (381)

**Table 35 Maintenance bypass cabinet dimensions**

Unit	Width	Depth	Height
inch	27.2	31.4	63
mm	690	825	1600

**Table 36 Multi-module paralleling cabinet dimensions**

1+1 Cabinet Type	Width	Depth	Height
1+N Narrow	27.2	31.4	63
Types A00, BR0, CR1, DR1	690	825	1600
1+N Cabinet Type	Width	Depth	Height
1+N Narrow	27.2	31.4	63
Types A00, E00, J00	690	825	1600
1+N Wide	58.5	31.4	63
All other types	1488x	825x	1600

## 8.2 Cable Lengths: Floor to Connection Point Inside UPS

To help calculate the total cable length required, refer to **Table 37** for the distance from the floor to selected connection points inside the NX. Determine the cable length required to reach the NX, then add the appropriate length from the table and adequate slack for repair and maintenance.

**Table 37 Distance to connection points on the NX UPS**

Connection Point on UPS	Distance	
	From Floor in. (mm)	From Top of Unit in. (mm)
Bypass AC input supply	30 (750)	30 (750)
UPS output AC	30 (750)	30 (750)
Neutral busbars—Input and Output	11 (280)	55 (1397)
Battery power	16 (400)	58 (1474)
Auxiliary cables: Monitor board (U2)	60 (1500)	20 (508)
Communications	55 (1400)	25 (635)
Ground	8 (197)	56 (14227)
Parallel Board	70(1780)	20(508)

# NOTES



DISCONTINUED  
PRODUCT

# Ensuring The High Availability Of Mission-Critical Data And Applications.

Emerson Network Power, the global leader in enabling business-critical continuity, ensures network resiliency and adaptability through a family of technologies—including Liebert power and cooling technologies—that protect and support business-critical systems. Liebert solutions employ an adaptive architecture that responds to changes in criticality, density and capacity. Enterprises benefit from greater IT system availability, operational flexibility and reduced capital equipment and operating costs.

## Technical Support / Service Web Site

[www.liebert.com](http://www.liebert.com)

### Monitoring

800-222-5877

[monitoring@emersonnetworkpower.com](mailto:monitoring@emersonnetworkpower.com)

Outside the US: 614-841-6755

### Single-Phase UPS

800-222-5877

[upstech@emersonnetworkpower.com](mailto:upstech@emersonnetworkpower.com)

Outside the US: 614-841-6755

### Three-Phase UPS

800-543-2378

[powertech@emersonnetworkpower.com](mailto:powertech@emersonnetworkpower.com)

### Environmental Systems

800-543-2778

Outside the United States

614-888-0246

### Locations

#### United States

1050 Dearborn Drive

P.O. Box 29186

Columbus, OH 43229

#### Europe

Via Leonardo Da Vinci 8

Zona Industriale Tognana

35028 Piove Di Sacco (PD) Italy

+39 049 9719 111

Fax: +39 049 5841 257

#### Asia

7/F, Dah Sing Financial Centre

108 Gloucester Road, Wanchai

Hong Kong

852 2572220

Fax: 852 28029250

While every precaution has been taken to ensure the accuracy and completeness of this literature, Liebert Corporation assumes no responsibility and disclaims all liability for damages resulting from use of this information or for any errors or omissions.

© 2006 Liebert Corporation

All rights reserved throughout the world. Specifications subject to change without notice.

® Liebert and the Liebert logo are registered trademarks of Liebert Corporation. All names referred to are trademarks or registered trademarks of their respective owners.

SL-25215\_REV6\_11-06

## Emerson Network Power.

The global leader in enabling Business-Critical Continuity™.

■ AC Power

■ Embedded Computing

■ Outside Plant

■ Racks & Integrated Cabinets

■ Connectivity

■ Embedded Power

■ Power Switching & Controls

■ Services

■ DC Power

■ Monitoring

■ Precision Cooling

■ Surge Protection

Business-Critical Continuity, Emerson Network Power and the Emerson Network Power logo are trademarks and service marks of Emerson Electric Co.

©2006 Emerson Electric Co.