



Liebert® AFC Packaged Air Cooled Free Cooling Chiller

Installer/User Guide

900 to 1800 kW 60 Hz

The information contained in this document is subject to change without notice and may not be suitable for all applications. While every precaution has been taken to ensure the accuracy and completeness of this document, Vertiv assumes no responsibility and disclaims all liability for damages resulting from use of this information or for any errors or omissions.

Vertiv recommends installing a monitored fluid detection system that is wired to activate the automatic closure of field-installed coolant fluid supply and return shut off valves, where applicable, to reduce the amount of coolant fluid leakage and consequential equipment and building damage. Refer to local regulations and building codes relating to the application, installation, and operation of this product. The consulting engineer, installer, and/or end user is responsible for compliance with all applicable laws and regulations relating to the application, installation, and operation of this product.

The products covered by this instruction manual are manufactured and/or sold by Vertiv. This document is the property of Vertiv and contains confidential and proprietary information owned by Vertiv. Any copying, use, or disclosure of it without the written permission of Vertiv is strictly prohibited.

Names of companies and products are trademarks or registered trademarks of the respective companies. Any questions regarding usage of trademark names should be directed to the original manufacturer.

Technical Support Site

If you encounter any installation or operational issues with your product, check the pertinent section of this manual to see if the issue can be resolved by following outlined procedures.

Visit <https://www.vertiv.com/en-us/support/> for additional assistance.

TABLE OF CONTENTS

1 Important Safety Instructions	1
1.1 General Instructions	7
1.2 Electric System	8
1.3 Personal Protective Equipment	8
1.4 Intended Use	8
1.4.1 Functional Limits	9
1.4.2 Operating Environment	9
1.4.3 Operating Limits	10
2 Nomenclature and Components	13
2.1 Air Cooled Chiller and Free Cooling Chiller Model Number Nomenclature	13
3 Product Description	17
3.1 Component Overview	18
3.1.1 General Chiller Components	18
3.2 Refrigerating System	19
3.2.1 Main Components	19
3.2.2 Safety Devices	22
3.2.3 Sensors and Instruments (Refrigeration Circuit)	24
3.3 Control System	31
3.3.1 Vertiv™ Liebert® iCOM™	31
3.4 Capacity and Efficiency Monitoring (Optional)	31
3.5 Integral Pumping (Optional)	32
3.6 Integral Hydraulic Kit (Optional)	32
4 Pre-installation Preparation and Guidelines	33
4.1 Installation	33
4.2 Site Preparation	34
4.2.1 Foundations and Positioning	35
4.2.2 Unit Preparation	35
4.2.3 Location	36
4.2.4 Space Requirements	37
4.3 Dimensions and Weights	38
5 Equipment Inspection and Handling	39
5.1 Inspection	39
5.2 Removing the Unit Using a Crane	40
6 Electrical Connections	45
6.1 Electric System Specifications	46
6.1.1 Power Supply	46
6.1.2 Local Codes	46

- 6.1.3 Power Supply Variability 46
- 6.1.4 Power Supply Connection 46
- 6.2 Connections 48
 - 6.2.1 Electrical Power Supply 48
 - 6.2.2 Ethernet Cable Connection 49
- 6.3 Electric Box and Main Switch 50
- 6.4 Electrical Service Entrances 51
- 7 Piping Requirements 53**
- 7.1 Refrigerant Charge Requirements 53
- 7.2 Water System Specifications 53
 - 7.2.1 System Protection 53
 - 7.2.2 Chilled Water Treatment 54
- 7.3 Freeze Protection 55
 - 7.3.1 Glycol Solutions 55
- 7.4 Filling the Chilled Water System 56
- 7.5 Draining 57
- 7.6 Field Piping Connections 57
 - 7.6.1 Vibration Damping 57
- 8 Checklist for Completed Installation 59**
- 8.1 Electrical System 59
- 8.2 Refrigeration System 59
- 8.3 Water System 59
- 8.4 Covers and Seals 59
- 8.5 Flow Switch 59
- 8.6 Alarms 59
- 8.7 Water Temperature 60
- 8.8 Compressor 60
- 9 Operation 61**
- 9.1 Power Up 61
- 9.2 Unit Start-up 61
 - 9.2.1 Compressor Pre-heating and Check 61
 - 9.2.2 Water System 62
- 9.3 Start 62
- 9.4 Stop 63
- 9.5 Restart Sequence 64
- 9.6 Free Cooling 64
- 10 Preventive Maintenance Checklist 65**
- 11 Maintenance 69**
- 11.1 Cleaning the Condenser and Free Cooling Coils 70
- 11.2 Lubrication of Pumps 72

11.3 Refrigeration System 72

 11.3.1 Refrigerant Charge 72

 11.3.2 Oil Charge 73

 11.3.3 Compressor Maintenance Schedule - Checks and Tests 73

 11.3.4 Filter Drier 73

11.4 Decommissioning and Winterizing the Water System 74

 11.4.1 Glycol 74

 11.4.2 Draining 74

12 Troubleshooting 75

Appendices 77

Appendix A: Technical Support and Contacts 77

Appendix B: Submittal Drawings 79

This page intentionally left blank

1 Important Safety Instructions

SAVE THESE INSTRUCTIONS

This manual contains important safety instructions that should be followed during the installation and maintenance of the Vertiv™ Liebert® AFC Packaged Air Cooled Free Cooling Chiller. Read this manual thoroughly before attempting to install or operate this unit.

Only qualified personnel should move, install or service this equipment.

Adhere to all warnings, cautions, notices and installation, operating, and safety instructions on the unit and in this manual. Follow all installation, operation, and maintenance instructions and all applicable national and local building, electrical, and plumbing codes.



WARNING! Arc flash and electric shock hazard. Can cause serious injury or death. Building and equipment damage may also result. Disconnect all local and remote electric power supplies and wear appropriate, OSHA-approved personal protective equipment (PPE) per NFPA 70E before working within the electric control enclosure. Customer must provide earth ground to unit, per NEC, CEC, and local codes, as applicable.

Verify with a voltmeter that power is Off. The Vertiv™ Liebert® iCOM™ controller does not isolate power from the unit, even in the “Unit Off” mode. Some internal components still require and receive power even during the “Unit Off” mode of the Liebert® iCOM™ controller. The factory-supplied, optional disconnect switch is inside the unit. The line side of this switch contains live high voltage. The only way to ensure that there is NO voltage inside the unit is to install and open a remote disconnect switch. Refer to unit electrical schematic.

Before proceeding with installation, read all instructions, verify that all the parts are included and check the nameplate to be sure the voltage matches available utility power. Follow all local codes.



WARNING! Risk of electric shock. Can cause serious injury or death. Building and equipment damage may also result. Open all local and remote electric power supply disconnect switches and verify that power is off with a voltmeter before working within any electric connection enclosures. The Liebert® iCOM™ controller does not isolate power from the unit, even in the "Unit Off" mode. Some internal components require and receive power even during the "unit off" mode of the Liebert® iCOM™ controller.

Installation, service, and maintenance work must be performed only by properly trained and qualified personnel and in accordance with applicable regulations and manufacturers' specifications. Opening or removing the covers to any equipment may expose personnel to lethal voltages within the unit even when it is apparently not operating and the input wiring is disconnected from the electrical source.



WARNING! Risk of short circuits and electric shock. Can cause serious injury or death. Building and equipment damage can result from cut insulation or damaged wires. Can cause overheated wiring, smoke, fire, activation of fire suppression systems and EMS personnel, and loss of power to fans. Verify that all wiring connections are tight and that all wiring is contained within the junction box prior to closing and securing the cover.

Insert CSA certified or UL listed bushings into holes and/or knockouts used to route wiring through metal panels to protect the wire insulation from contact with sheet metal edges.



WARNING! Risk of improper wire sizing/rating and loose electrical connections causing overheated wire and electrical connection terminals resulting in smoke or fire. Can cause serious injury or death. Building and equipment damage may also result. Use correctly sized copper wire only and verify that all electrical connections are tight before turning power On. Check all electrical connections periodically and tighten as necessary.



WARNING! Risk of contact with high speed rotating fan blades. Can cause serious injury or death. Open all local and remote electric power supply disconnect switches, verify with a voltmeter that power is off, and verify that all fan blades have stopped rotating before working in the unit cabinet or on the fan assembly. If control voltage is applied, the fan motor can restart without warning after a power failure. Do not operate the unit with any or all cabinet panels removed. Do not operate upflow units without installing a plenum, duct work or guard over the blower opening(s) on the top surface of the unit cabinet. Ductwork must be connected to the blower(s), or a plenum must be installed on the blower deck for protection from rotating blower wheel(s) on upflow units.



WARNING! Risk of improper wiring, piping, moving, lifting and handling. Can cause serious injury or death. Building and equipment damage may also result. Installation and service of this equipment should be done only by qualified personnel who have been specially-trained in the installation of air-conditioning equipment and who are wearing appropriate, OSHA-approved PPE.



WARNING! Risk of top heavy unit falling over when improperly lifted or moved. Can cause serious injury or death. Building and equipment damage may also result. Read all of the following instructions and verify that all lifting and moving equipment is rated for the weight of the unit before attempting to move, lift, remove packaging from or prepare the unit for installation. Unit weights are specified in [Dimensions and Weights](#) on [page 38](#) .



WARNING! Risk of extremely heavy fan modules dropping downward suddenly. Can cause serious injury or death. Building and equipment damage may also result. Fan modules weigh in excess of 125 lb (56.7 kg) each. Support fan modules before removing mounting hardware. Use caution to keep all body parts out of the fan module pathway of movement during removal or repositioning. Only properly trained and qualified personnel should work on this equipment.

More than one person may be required to complete the assembly and installation. Installer(s) must be properly trained and qualified to lift, move, and manipulate very heavy equipment from floor level to the top of the unit. Wear appropriate, OSHA-approved PPE when moving, lifting, installing, and removing the fan(s) and plenum. Read and follow the lifting equipment and/or ladder manufacturer's operating instructions and safety requirements.



CAUTION: Risk of contact with sharp edges, splinters, and exposed fasteners. Can cause injury. Only properly trained and qualified personnel wearing appropriate, OSHA-approved PPE should attempt to move, lift, remove packaging from or prepare the unit for installation.



CAUTION: Risk of improper handling, heavy and lengthy parts. Can cause injury. Building and Equipment damage may also result. Cabinet panels can exceed 5 feet (1.5 m) in length and weigh more than 35 lb. (15.9 kg). Follow relevant OSHA lifting recommendations and consider using a two-person lift for safe and comfortable removal and installation of cabinet panels. Only properly trained and qualified personnel wearing appropriate, OSHA-approved PPE should attempt to remove or install cabinet panels.



CAUTION: Risk of improper moving, lifting and handling. Can cause injury. Building and equipment damage may also result. Only properly trained and qualified personnel should work on this equipment. Evaporator fan modules weigh in excess of 125 lb (56.7 kg). Use proper lifting techniques and wear appropriate OSHA approved PPE to avoid injury and dropping the fan module during removal. Equipment used in handling/lifting, and/or installing the fan assembly must meet OSHA requirements. Use handling/lifting equipment rated for the weight of the fan assembly. Use ladders rated for the weight of the fan assembly and technicians if used during installation. Refer to handling/lifting, and/or installation equipment operating manual for manufacturer's safety requirements and operating procedures.



CAUTION: Risk of heavy unit falling into defective raised floor. Can cause injury and equipment damage. Prior to installation, all floor tiles immediately around floor stand are to be removed and inspected. Make sure tiles are not cracked, and ribs have not been cut. If free from defects, re-install. Replace with new tiles if defects are found.



CAUTION: Risk of contact with hot surfaces. Can cause injury. Personal burn injury can be the result of touching an electronics housing, fan motor, and some electrical components that are extremely hot during unit operation. Allow sufficient time for them to cool to a touch safe temperature before working within the unit cabinet. Use extreme caution and wear appropriate, OSHA-approved PPE when working on or near hot components, including when replacing or performing maintenance on the fans.



CAUTION: Risk of contact with hot surfaces. Can cause injury. Personal burn injury can be the result of touching a humidifier reservoir pan and/or water contained within the pan, and some electrical components that are extremely hot during unit operation. Allow sufficient time for them to cool to a touch-safe temperature before working within the unit cabinet.

Use extreme caution and wear appropriate, OSHA-approved PPE when working on or near hot components, including when replacing or performing maintenance on the infrared humidifier parts inclusive of its bulbs, metal enclosure, humidifier reservoir pan and/or water contained within the pan, and drain tubing. All infrared humidifier parts are very hot during and remain very hot shortly after operation.



CAUTION: Risk of improper handling of boiling water. Can cause leaks, equipment and building damage, or burn injury. The unit requires a drain line that may contain boiling water. Only properly trained and qualified personnel wearing appropriate, OSHA-approved PPE should service the drain line or work on parts near or connected to the drain line.



CAUTION: Risk of improper piping installation, leak checking, fluid chemistry and fluid maintenance. Can cause injury. Building and equipment damage may also result. Installation and service of this equipment should be done only by qualified personnel who have been specially-trained in the installation of air conditioning equipment and who are wearing appropriate, OSHA-approved PPE.



CAUTION: Risk of smoke generation. Can cause injury. Can cause fire suppression and alarm system activation, resulting in building evacuation and mobilization of emergency fire and rescue services. Start-up operation of optional electric reheat elements can create smoke or fumes that can activate the facility alarm and fire suppression system. Prepare and take appropriate steps to manage this possibility. Activating reheat during initial start-up may burn off particulates from electric reheat elements. Before beginning initial start-up checks, make certain that unit was installed according to the instructions in this manual. All exterior panels must be in place.



CAUTION: Risk of exposure to harmful noise levels. Can cause hearing injury or loss. Depending on the installation and operating conditions, a sound pressure level greater than 70 dB(A) may arise. Take appropriate technical safety measures. Operating personnel must wear appropriate, OSHA-approved PPE and observe all appropriate hearing protection safety requirements.

NOTICE

Risk of improper power supply connection. Can cause equipment damage and loss of warranty coverage.

Prior to connecting any equipment to a main or alternate power source (for example: backup generator systems) for start-up, commissioning, testing or normal operation, ensure that these sources are correctly adjusted to the nameplate voltage and frequency of all equipment to be connected. In general, power source voltages should be stabilized and regulated to within $\pm 10\%$ of the load nameplate nominal voltage. Also, ensure that no three phase sources are single phased at any time.

NOTICE

Risk of piping system corrosion and freezing fluids. Can cause leaks resulting in equipment and expensive building damage. Cooling coils, heat exchangers, and piping systems are at high risk of freezing and premature corrosion. Fluids in these systems must contain an inhibitor to prevent premature corrosion.

The system coolant fluid must be analyzed by a competent fluid treatment specialist before start-up to establish the inhibitor level and evaluated at regularly scheduled intervals throughout the life of the system to determine the pattern of inhibitor depletion. The fluid complexity and variations of required treatment programs make it extremely important to obtain the advice of a competent and experienced fluid treatment specialist and follow a regularly scheduled coolant fluid system maintenance program.

Fluid chemistry varies greatly as do the required additives, called inhibitors, that reduce the corrosive effect of the fluids on the piping systems and components.

The chemistry of the coolant fluid used must be considered, because some sources may contain corrosive elements that reduce the effectiveness of the inhibited formulation. Sediment deposits prevent the formation of a protective oxide layer on the inside of the coolant system components and piping. The coolant fluid must be treated and circulating through the system continuously to prevent the buildup of deposits and/or growth of bacteria. Proper inhibitor maintenance must be performed to prevent corrosion of the system.

Consult fluid manufacturer for testing and maintenance of inhibitors.

Commercial grade coolant fluid is generally less corrosive to the common metals of construction than water itself. It will, however, assume the corrosivity of the coolant fluid from which it is prepared and may become increasingly corrosive with use if not properly inhibited.

Vertiv recommends installing a monitored fluid detection system that is wired to activate the automatic closure of field installed coolant fluid supply and return shutoff valves to reduce the amount of coolant fluid leakage and consequential equipment and building damage. The shutoff valves must be sized to close off against the maximum coolant fluid system pressure in case of a catastrophic fluid leak.

NOTICE

Risk of no flow condition. Can cause equipment damage. Do not leave the water/coolant fluid supply circuit in a no flow condition. Idle fluid allows the collection of sediment that prevents the formation of a protective oxide layer on the inside of tubes. Keep unit switched on and water/coolant fluid supply circuit system operating continuously.

NOTICE

Risk of clogged or leaking drain lines and leaking water supply lines. Can cause equipment and building damage.

This unit requires a water drain connection. Drain lines must be inspected at start-up and periodically, and maintenance must be performed to ensure that drain water runs freely through the drain system and that lines are clear and free of obstructions and in good condition with no visible sign of damage or leaks. This unit may also require an external water supply to operate.

Improper installation, application, and service practices can result in water leakage from the unit. Water leakage can result in catastrophic and expensive building and equipment damage and loss of critical data center equipment.

Do not locate unit directly above any equipment that could sustain water damage.

We recommend installing a monitored fluid detection system to immediately discover and report coolant fluid system leaks.

NOTICE

Risk of leaking chilled water lines. Can cause equipment and building damage.

Lines and joints must be inspected regularly. Improper installation, application and service practices can result in water leakage from the unit. Water leakage can result in severe property damage and loss of critical data center equipment. Do not locate unit directly above any equipment that could sustain water damage.

NOTICE

Risk of a catastrophic water circuit rupture. Can cause expensive building and equipment damage.

NOTICE

Risk of passageway interference. Can cause unit and/or structure damage. The unit may be too large to fit through a passageway while on or off the skid. Measure the unit and passageway dimensions, and refer to the installation plans prior to moving the unit to verify clearances.

NOTICE

Risk of improper storage. Can cause unit damage.

Please follow recommended storage guidelines in [Storage](#) on page 10 .

NOTICE

Risk of a leaking coil due to freezing and/or corrosion. Can cause equipment and serious building damage.

Cooling and heat rejection coils, heat exchangers and piping systems that are connected to open cooling towers or other open water/glycol systems are at high risk for freezing and premature corrosion. Fluids in these systems must contain the proper antifreeze and inhibitors to prevent freezing and premature coil corrosion. The water or water/glycol solution must be analyzed by a competent water treatment specialist before start-up to establish the inhibitor requirement. The water or water/glycol solution must be analyzed every six months to determine the pattern of inhibitor depletion. The complexity of water-caused problems and their correction makes it important to obtain the advice of a water treatment specialist and follow a regularly scheduled maintenance program.

NOTICE

Risk of piping system corrosion and freezing fluids. Can cause leaks resulting in equipment and very expensive building damage. Cooling coils and piping systems are at high risk of freezing and premature corrosion. Fluids in these systems must contain the proper antifreeze and inhibitors to prevent freezing and premature coil and piping corrosion. The water or water/glycol solution must be analyzed by a competent local water treatment specialist before start up to establish the inhibitor and antifreeze solution requirement and at regularly scheduled intervals throughout the life of the system to determine the pattern of inhibitor depletion.

The complexity of water/glycol solution condition problems and the variations of required treatment programs make it extremely important to obtain the advice of a competent and experienced water treatment specialist and follow a regularly scheduled coolant fluid system maintenance program.

Water chemistry varies greatly by location, as do the required additives, called inhibitors, that reduce the corrosive effect of the fluids on the piping systems and components. The chemistry of the water used must be considered, because water from some sources may contain corrosive elements that reduce the effectiveness of the inhibited formulation. Sediment deposits prevent the formation of a protective oxide layer on the inside of the coolant system components and piping. The water/coolant fluid must be treated and circulating through the system continuously to prevent the buildup of sediment deposits and or growth of sulfate reducing bacteria. Proper inhibitor maintenance must be performed in order to prevent corrosion of the system. Consult glycol manufacturer for testing and maintenance of inhibitors.

Commercial ethylene glycol, when pure, is generally less corrosive to the common metals of construction than water itself. It will, however, assume the corrosivity of the water from which it is prepared and may become increasingly corrosive with use if not properly inhibited.

We recommend installing a monitored fluid detection system that is wired to activate the automatic-closure of field installed coolant fluid supply and return shut off valves to reduce the amount of coolant fluid leakage and consequential equipment and building damage. The shut off valves must be sized to close off against the maximum coolant-fluid system pressure in case of a catastrophic fluid leak.

NOTICE

This equipment is required to be installed only in locations not accessible to the general public. Installation, service, and maintenance work must be performed only by properly trained and qualified personnel and in accordance with applicable regulations and manufacturers' specifications.

NOTICE

This appliance is not intended for use by persons (including children) with reduced physical, sensory or mental capabilities, or lack of experience and knowledge, unless they have been given supervision or instruction concerning use of the appliance by a person responsible for their safety.

Children should be supervised to ensure that they do not play with the appliance.

**1.1 General Instructions**

Intended Readers	This user manual is intended for transport, installation, and maintenance personnel. The end user can only switch the unit ON and OFF (see Electric Box and Main Switch on page 50).
Authorized Personnel	The operations described in this manual must be made by technical staff, expressly authorized in compliance with the regulations in force at the installation site.
Read this manual.	Carefully read the manual before performing any operation on the unit.
Keep this manual.	Keep the manual during the complete life-span of the unit. Keep the diagrams provided with the unit (wiring, refrigerating circuit, etc.). They are a part of the instructions for use. If you move or sell the unit, transfer the manual and the diagrams together with the unit. This manual may be subject to modification. For complete and up-to-date information always consult the manual supplied with the unit.
Intended Use	Exclusively employ the unit for the purpose for which it has been designed (see Intended Use on the next page). The improper use of the unit exonerates the manufacturer of any responsibility.
Do not modify the unit.	Do not modify the unit in any way, including the control system and the software. Any modification to the unit exonerates the manufacturer of any responsibility.
Warning Labels	Pay attention to the warning labels on the unit.

1.2 Electric System



WARNING! Unit contains potentially lethal voltage in some circuits.

Risk of arc flash and electric shock. Can cause injury or death.

- Open all local and remote unit electric power disconnect switches, verify with a voltmeter that power is OFF and wear protective equipment per local standard before working within the electric control enclosure.
- The panel key supplied with the unit must be kept by the person responsible for maintenance.



WARNING! The electric and control enclosures can retain a stored high-voltage electrical charge for up to 10 minutes. Risk of electric shock. Can cause serious injury or death.

Before working within the unit electric and control enclosures proceed as follows:

- Open all local and remote unit electric power disconnect switches.
- Wait 10 minutes.
- Verify with a voltmeter that power is OFF.

Only properly trained and qualified personnel may perform repair, maintenance and cleaning.

1.3 Personal Protective Equipment

As a general rule, always wear the following PPE (Personal Protective Equipment):



CAUTION: Components at high temperature (discharge line and compressor at about 194°F [90°C]). Always wear temperature resistant gloves when operating on the unit.

Ensure that all required safety measures are followed such as: wearing protective clothing (gloves, safety glasses, and shoes), using appropriate tools, employing qualified and skilled technicians (electricians, refrigeration engineers) trained in the use of flammable refrigerants and following local regulations.

1.4 Intended Use

The Vertiv™ Liebert® AFC units have been designed and manufactured for production of chilled water. They are made of two refrigerating circuits, each include a screw compressor, air cooled condenser, and a shell and tube evaporator.

The tube evaporators of both of the circuits are coupled in the same heat exchanger where the water is chilled.

The Liebert® AFC chillers are factory assembled, functionally tested and pre-charged with refrigerant prior to shipment. All the internal wiring is completed, installed, and functionally tested at the factory prior to shipment. Only electrical and water connections must be made at the installation site.

See [Product Description](#) on page 17 for details about the unit's structure, versions, and optional components.

1.4.1 Functional Limits

Refrigerant

Vertiv™ Liebert® AFC chillers are designed for use with refrigerants including: R-134a, R-513A, R-1234ze, and R-515B.

According to ASHRAE 34, R134a, and R513A are classified in safety group A1, while R1234ze(E) is classified in safety group A2L: lower flammability.

According to ASTM E681-04, @ 69.8°F (21°C) R1234ze is not flammable, so the safety data sheet for this refrigerant says that it is not flammable with no issue stocking or transporting the refrigerant cylinders; see [Refrigerating System](#) on page 19 .

One of the characteristics of this refrigerant (R1234ze) is the absence of flammable mixture with air under 69.8°F (21°C) of ambient and controlled humidity conditions; however when humidity or temperature goes up, this refrigerant can become flammable and can represent a potential danger if flammability risks are not properly mitigated.



WARNING! Risk of components failure or breakage. Do not use other refrigerants. Contact the manufacturer.

Electrical System Requirements

Voltage: 460 V/3 phase/60 Hz



WARNING! Risk of components failure or breakage. Do not use different voltage. Contact the manufacturer.

1.4.2 Operating Environment

Vertiv™ Liebert® AFC chillers are designed for outdoor installation under the following conditions:

Minimum supply fluid temperature is ~ 54°F (12.2°C)

Maximum supply fluid temperature is ~ 77°F (25°C)

Outdoors; [Installation](#) on page 33 for A2L restrictions.

Max Altitude

< 6,560 ft. (2000 m) slm

Storage Conditions

Temperature 14°F - 113°F (-10°C - +45°C)

Humidity: 5 - 80% non-condensing

See [Storage](#) on the next page for A2L restrictions.

1.4.3 Operating Limits

The below chart indicates the general operating range and limits of the Vertiv™ Liebert® AFC chiller range. This is to be utilized as a guide and reference only as the operating range can vary by model, refrigerant, unit size, and any ETO (Engineered to Order) options. Any applications above 113°F ambient air temperature should be reviewed by a Vertiv representative to ensure proper unit selection and performance.

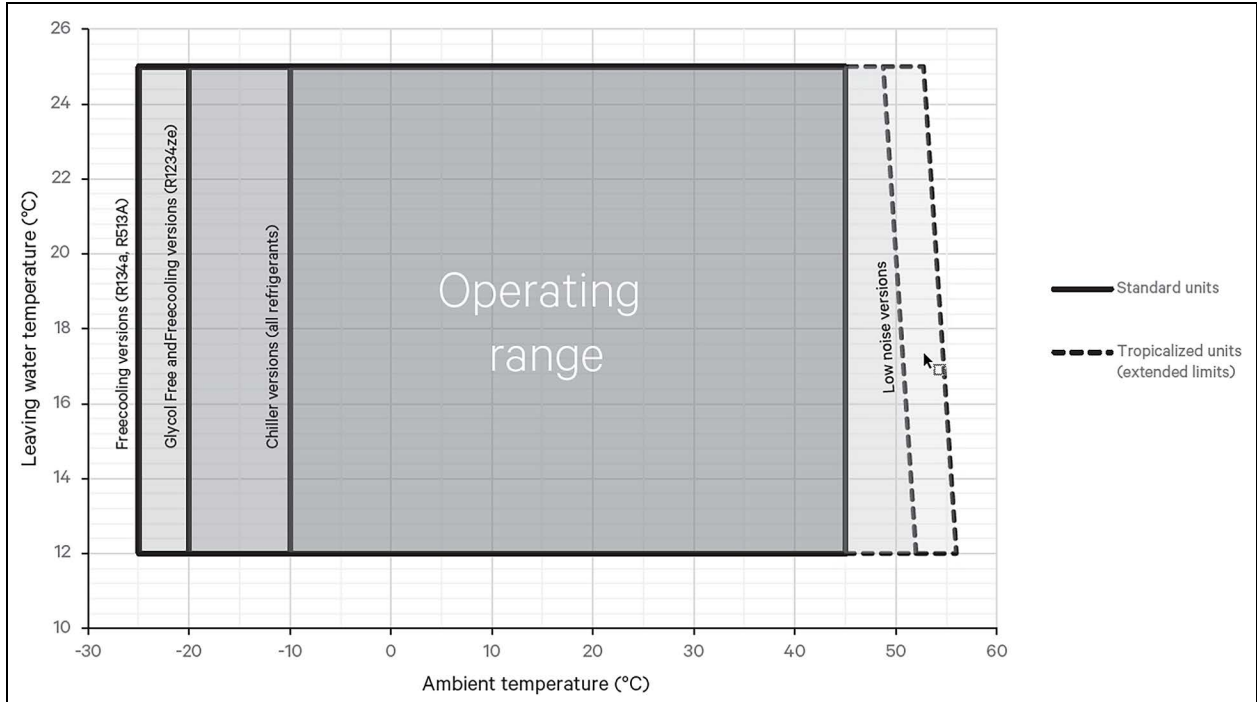

This is intended as a physical limit referring to rejection capacity of the condenser at the HP switch threshold, not considering intermediate protection functions normally active in the standard Vertiv controller.

Storage

Unit should be stored within the following ambient conditions:

Table 1.1 Ambient Conditions

Item	Requirement
Storage Conditions	Temperature 14°F - 113°F (-10°C - +45°C) Humidity: 5 - 80% non-condensing
Ambient Temperature	-20°F - 113°F (-28.9°C - 45°C) [Min and Max air temperatures can vary by model and chiller design.] NOTE: The ambient temperature must not go below -4°F (-20°C), because in this condition R1234ze pressure is below the ambient ones.
Ambient Humidity	< 80% non-condensing
Storage Time	The total storage time should not exceed one month; for storage with high RH ambient or near the sea storage should not exceed two weeks. If storage is longer than six months, check the functionality of the sensors and other electronic devices before putting the unit into operation.

Warnings for units equipped with A2L gas:



WARNING! Storage must only take place outdoors and away from any opening or downward compartment (for a list of examples see [Installation](#) on page 33) and from electrical or mechanical devices (such as forklifts, trucks, etc.) that can generate ignition sources.



WARNING! It is absolutely forbidden to exceed the indicated thermal limits - both maximum and minimum - to avoid any leakage from the safety valves and to avoid depression inside the refrigeration circuit that could cause oxygen to enter.



WARNING! If it is impossible to observe these requirements, it is mandatory to remove the gas contained in the unit by a qualified technician; contact Vertiv or its representative.

This page intentionally left blank

2 Nomenclature and Components

This section describes the model number for Vertiv™ Liebert® Air Cooled Chiller and Vertiv™ Liebert® Free Cooling Chiller units and components.

2.1 Air Cooled Chiller and Free Cooling Chiller Model Number Nomenclature

Table 22 below describes each digit of the model number.

Table 2.1 Model Number Digits

Model Number Digits 1-20																			
1	2	3	4	5	6	7	8	9	10	11	12	13	14	15	16	17	18	19	20
F	H	3	1	7	5	H	G	A	E	0	0	0	B	2	0	1	2	0	0

Model Number Digits 21-40																			
21	22	23	24	25	26	27	28	29	30	31	32	33	34	35	36	37	38	39	40
0	0	0	0	0	0	0	0	0	0	0	0	0	0	0	A	X	X	X	X

Table 2.2 Air Cooled Chiller and Free Cooling Chiller Model Number Nomenclature

Digit	Description
Digit 1 = Type	
	C = Chiller
	F = Chiller with direct free cooling
	N = Chiller with indirect free cooling (glycol free)
Digit 2 = Compressor	
	H = Dual fixed
	I = Fixed + inverter
	2 = Dual inverter
Digit 3 = Refrigerant	
	Z = R1234ze
	3 = R-513A
	B = R-515B
	4 = R134a
Digit 4-6 = Capacity	
	XXX = MW capacity x 1000

Table 2.2 Air Cooled Chiller and Free Cooling Chiller Model Number Nomenclature (continued)

Digit	Description	
Digit 7 = Water Delta		
	H = Data center (18°F)	
Digit 8 = Efficiency		
	G = High efficiency	
Digit 9 = Voltage		
	A = 460V/3PH/60Hz UL/CSA	
Digit 10 = Fans & Acoustic		
	E = EC high efficiency	
	L = EC low noise	
	Q = EC ultra quiet	
Digit 11 = Hydraulic Package		
	0 = No pump or hydraulic kit	
	1 = Standard head pump	Fixed flow hydraulic kit
	2 = High head pump	
	3 = Standard head pump with SB	
	4 = High head pump with SB	
	5 = Inverter pump	
	6 = Inverter pump with SB	
	7 = Fixed flow hydraulic kit only	
	A = Inverter pump	Variable flow hydraulic kit
	B = Inverter pump with SB	
	C = Variable flow hydraulic kit only	
Digit 12 = Adiabatic		
	0 = None	
Digit 13 = Coil Coating (C/F/N)		
	0/D/A = No coating	
	1/E/B = Base coating (+1,000 hr) ASTM B117	
	2/F/C = Premium coating/corrosive (+15,000 hr) ASTM B117	
Digit 14 = Controls		
	B = Liebert® iCOM™3 with 10 in. graphical touch display	

Table 2.2 Air Cooled Chiller and Free Cooling Chiller Model Number Nomenclature (continued)

Digit		Description	
Digit 15 = DX Options			
1 = Suction valve + single relief valve			
2 = Suction valve + dual relief valves			
Digit 16 = Ambient			
0 = Standard ambient			
A = Low ambient freeze protection (customer supplied power to heat tracing)			
B = High ambient			
Digit 17 = Power Supply			
	Power Supply Line	Control	Buffer Module
0	Single	None	No
1	Single	None	Yes
2	Single	120V UPS	No
3	Single	120V UPS	Yes
A	ATS switched	None	No
B	ATS switched	None	Yes
C	ATS switched	120V UPS	No
D	ATS switched	120V UPS	Yes
Digit 18 = Filters and Protection			
0 = None			
1 = Condenser filters			
2 = Protection grid			
3 = Condenser filters + protection grid			
4 = Aesthetic lateral panels			
Digit 19 = Packaging			
0 = Shrink wrap			
1 = Crating + skid for flat rack			
2 = Crating			
Digit 20 = Flow Meter			
0 = None			
1 = Flow meter			
Digit 21 = Connection Type			
0 = Grooved			
1 = ANSI flanged			

Table 2.2 Air Cooled Chiller and Free Cooling Chiller Model Number Nomenclature (continued)

Digit	Description
Digit 22 = Harmonic Filtration	
0 = None	
Digit 23-35 = Open	
0 = Open	
Digit 36 = ETO	
A = No ETOs, (Any alpha letter except S)	
S = ETO requested	
Digits 37-40 = Factory Configuration Code	
<p>NOTE: Not all models covered by the nomenclature are certified models.</p>	

3 Product Description

Vertiv™ Liebert® AFC air cooled chillers have been designed for the production of chilled water.

There are three main versions available:

- Air Cooled Chiller
- Air Cooled Direct Free Cooling Chiller
- Air Cooled Indirect Free Cooling Chiller (glycol free)

The Liebert® AFC chiller is designed with industry leading technology and standards culminating decades of data center experience in a robust, efficient, and reliable chiller design and is complete with all the elements necessary for automatic and efficient operation. Each unit is delivered factory assembled, functionally tested and pre-charged with refrigerant prior to shipment.

All units are equipped with two independent refrigerant circuits, each consisting of: an air cooled condenser, semi-hermetic screw compressor (with or without inverter), shell and tube evaporator, on-board controls, and other critical components. Other refrigeration system components include: valves, a filter drier, shut-off valves, and an electronic expansion valve.

The hydraulic circuit consists of grooved piping with victaulic fittings, a flow switch, and other safety devices and two-way valves to manage the transition of water flow in different operating modes.

The indirect free cooling (glycol free) chiller versions include an intermediate plate heat exchanger to separate the internal free cooling loop (typically with a glycol/water mixture) from the process side loop (utilizing 100% water). An inverter driven pump recirculates the glycol/water mixture through the free cooling coils and plate heat exchanger. The evaporator and the hydraulic piping in which water flows are protected from freezing with electrical heating elements.

The semi-hermetic screw compressors included in every AFC chiller include the following protection/safety devices: an oil heater, an internal safety valve, an oil level (optional), an electronic motor winding temperature safety, an oil temperature, and screw rotation.

The Liebert® AFC chillers configured with screw compressors with an integrated inverter, the operating stability and operating efficiency greatly improve due to compressor speed modulation and optimized management of the volume ratio (suction volume divided by discharge volume). The on-board AFC Vertiv™ Liebert® iCOM™ regulates the inverter temperature through internal cooling and continuously monitors safety functions with integrated sensors such as high pressure, low pressure, motor temperature, and oil level (optional) and temperature alarms.

Units with an inverter duty compressor include a line reactor; this device is essential and reduces the harmonics transmitted by the inverter to the power supply network.

Liebert® AFC units are controlled by the Liebert® iCOM™ controller which manages all the operational functions and unit control. The user can set and/or modify the operating parameters using the HMI display keyboard installed on the electrical panel.

The electrical control panel is equipped with all the necessary safety and operating devices to ensure reliable operation and safety.

3.1 Component Overview

3.1.1 General Chiller Components

Figure 3.1 Typical Vertiv™ Liebert® AFC Component Overview

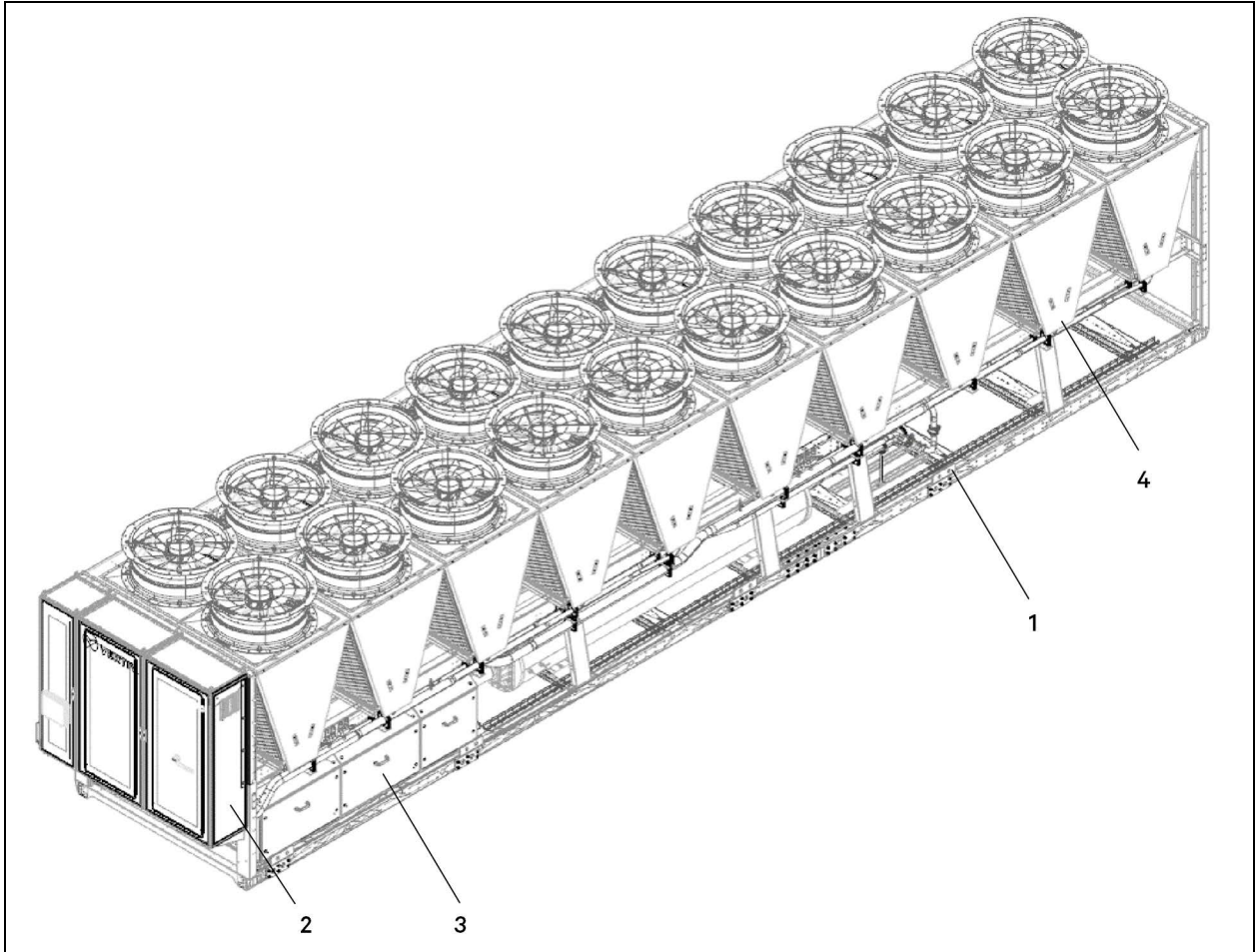

Item	Description
1	Supporting structure
2	Electric panel
3	Compressors box
4	Coils/fans V block

Figure 3.2 Typical Chiller Connections (without Pump)

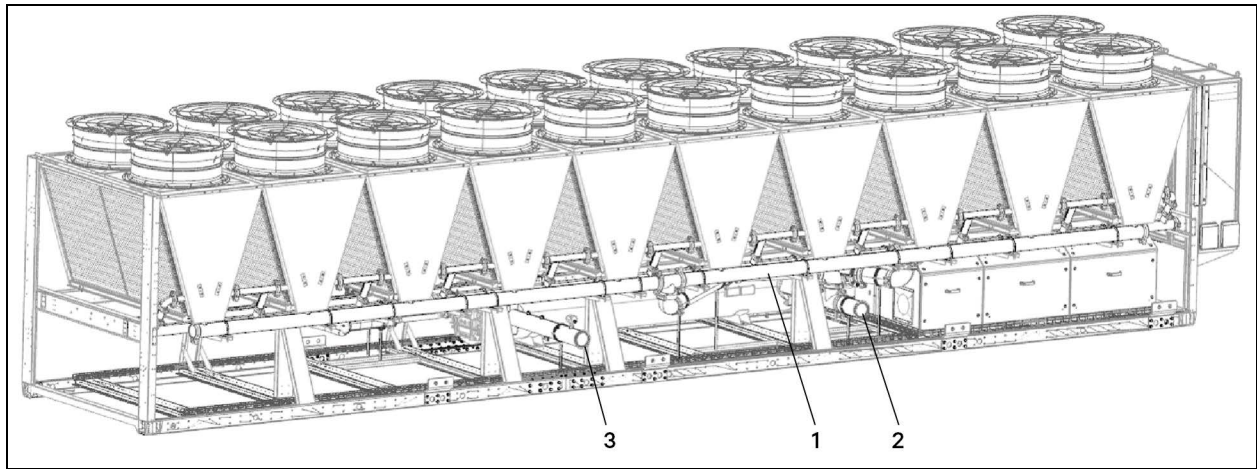

Item	Description
1	Evaporator
2	Fluid inlet connection
3	Fluid outlet connection

NOTE: Unit shown is a chiller only variant. Connection locations may vary depending on configured model.

3.2 Refrigerating System

3.2.1 Main Components

The unit is equipped with two independent refrigerating circuits, composed of an air cooled condenser, a semi-hermetic screw compressor, and shell-tube evaporator. The evaporator tubes of both circuits are coupled in the same shell heat exchanger. The chilled water flows through the shell side with the refrigerant flowing through the tube side. A shut-off valve is installed on the discharge of each compressor. The components of the liquid line include, but are not limited to:

- Charging valves
- Filter driers
- Moisture indicator
- Electronic expansion valve

Figure 3.3 Typical AFC Component Overview

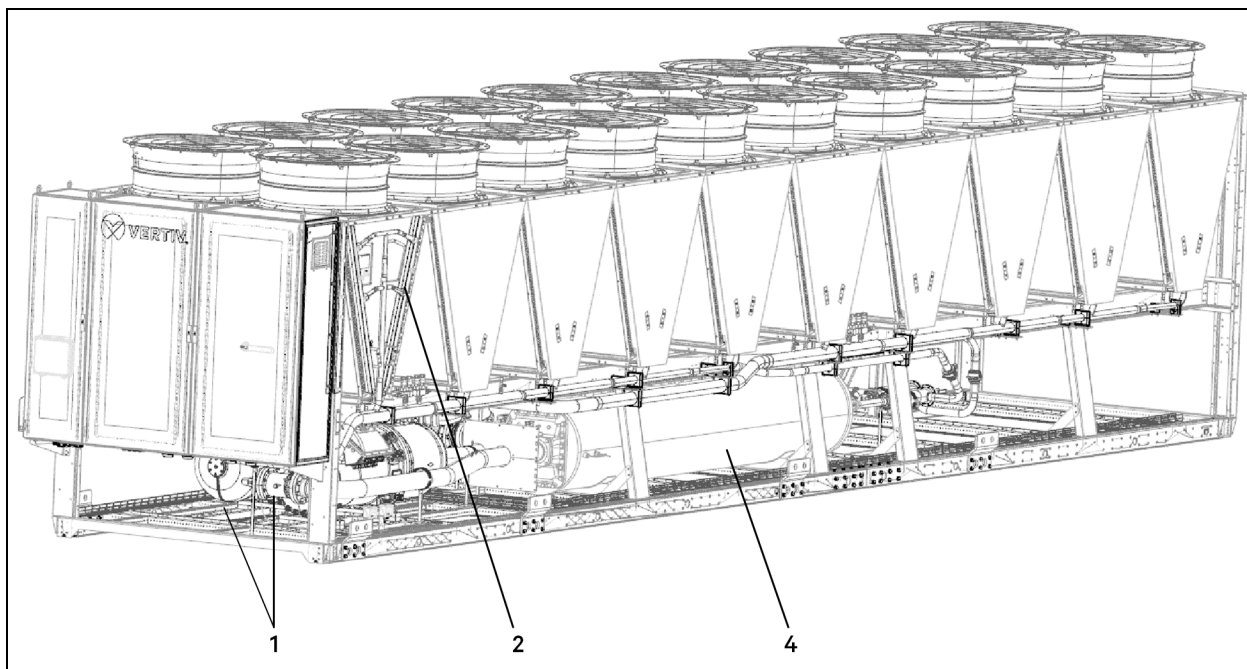

Item	Description
1	Semi-hermetic screw compressors
2	Microchannel condensers
3	Fans
4	Shell tube evaporator

Figure 3.4 Expansion Valve Circuits and Filter Drier Circuits

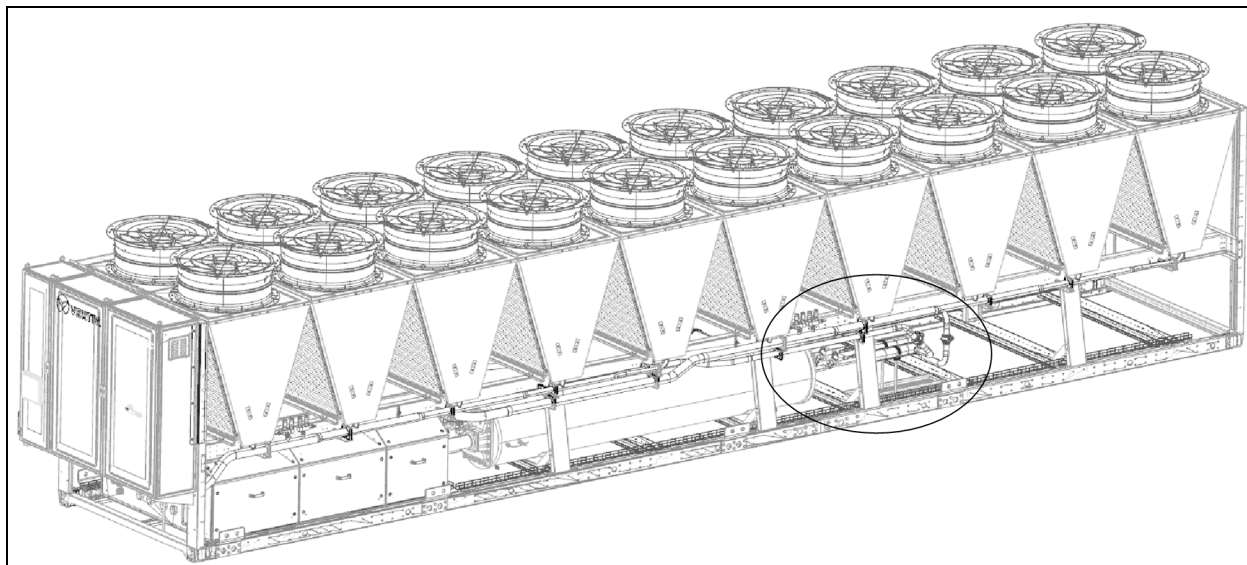

Item	Description
1	Expansion valve circuit 1
2	Expansion valve circuit 2
3	Filter drier circuit 1
4	Filter drier circuit 2

3.2.2 Safety Devices

Each refrigeration circuit is provided with the following safety devices:

Figure 3.5 Safety Valve Locations

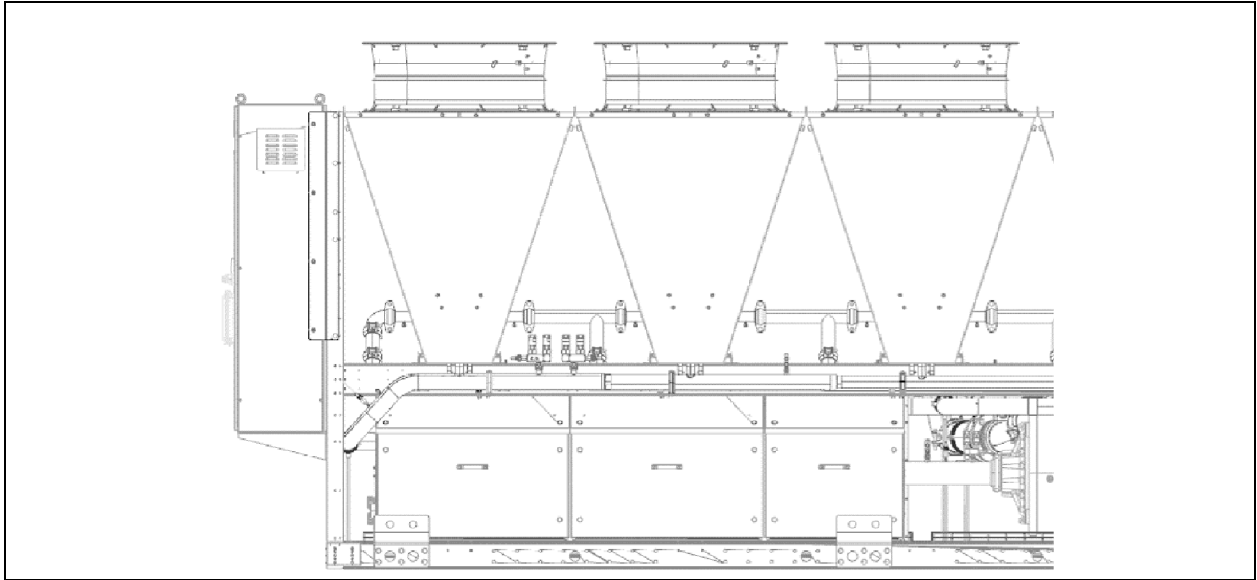

Item	Description
1	High pressure safety valve(s) circuit #1
2	High pressure safety valve(s) circuit #2
3	Low pressure safety valve(s) circuit #1
4	Low pressure safety valve(s) circuit #2

Consult local building and plumbing codes for installation requirements of additional pressure relief devices when isolation valves are field installed. Do not isolate any refrigerant circuits from over pressurization protection.

See also [Calibrations](#) on page 1.



WARNING! Make sure that the safety valves are always free to discharge. Do not cover the safety valves. For units with A2L refrigerant, please follow the safety valve connection guide.

NOTICE

The operation, servicing, and maintenance of pressure equipment and pressure assemblies should be performed by a certified technician.

The shut-off valves, installed between vessel and safety valve, allow removing the valve for periodic checking or replacement without blowing off all the refrigerant from a section of the system.

The safety valves are installed in the open position and the ball spindle is protected by means of a cap screwed to the body and sealed with lead.

Figure 3.6 High Pressure Switch Locations

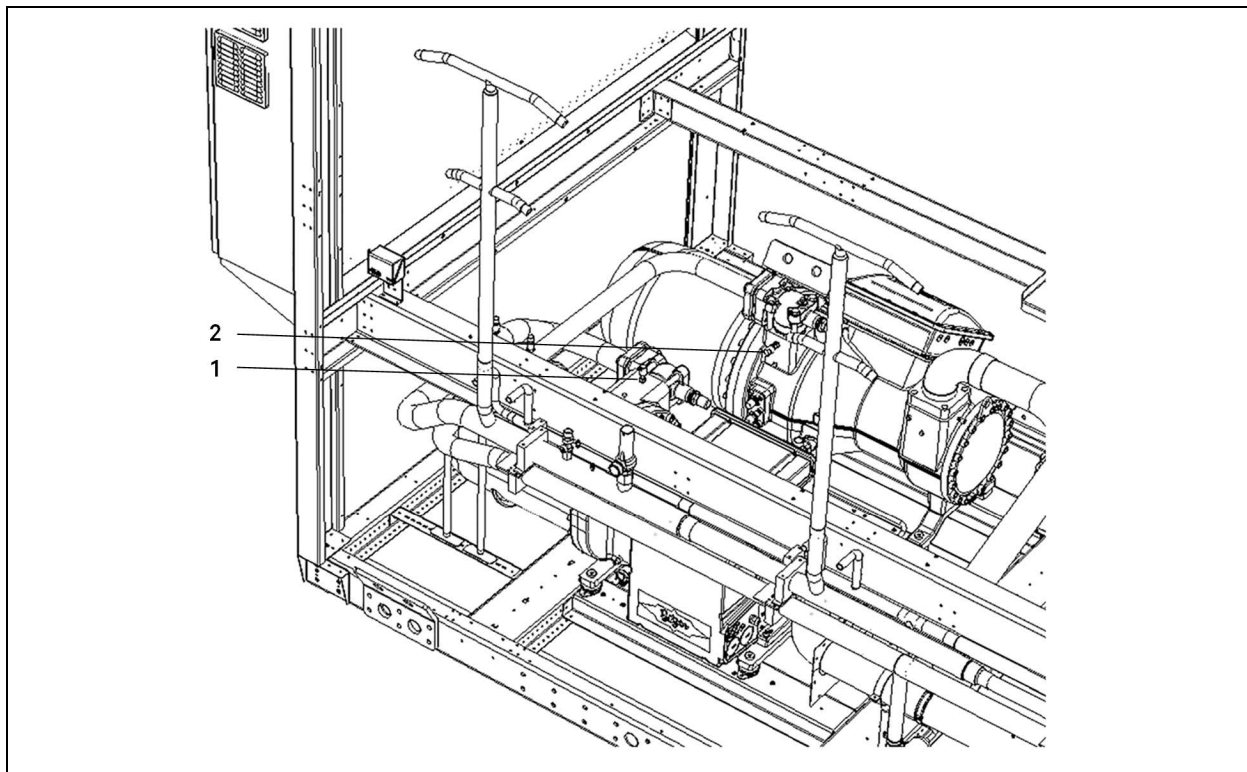

Item	Description
1	High pressure switch circuit #1
2	High pressure switch circuit #2

3.2.3 Sensors and Instruments (Refrigeration Circuit)

Each refrigeration circuit is provided with the following sensors and instruments:

Figure 3.7 Typical Sensor Locations

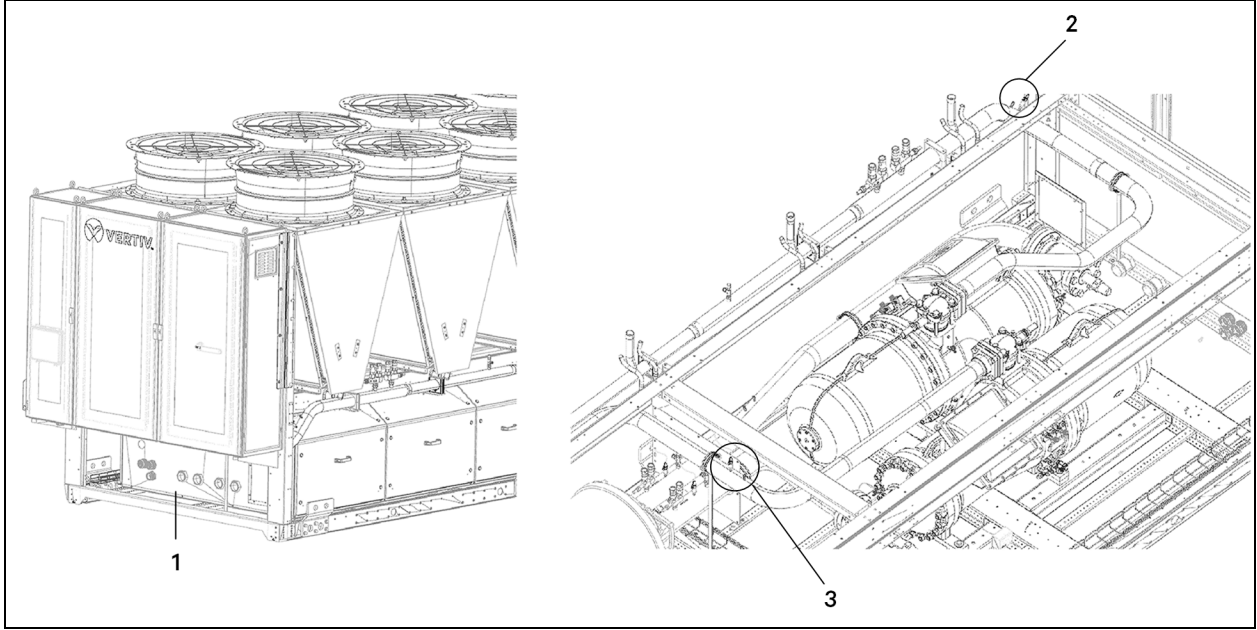

Item	Description
1	Semi-hermetic screw compressors box
2	Pressure transducer high pressure circuit 1
3	Pressure transducer high pressure circuit 2

Figure 3.8 Typical Sensor Locations

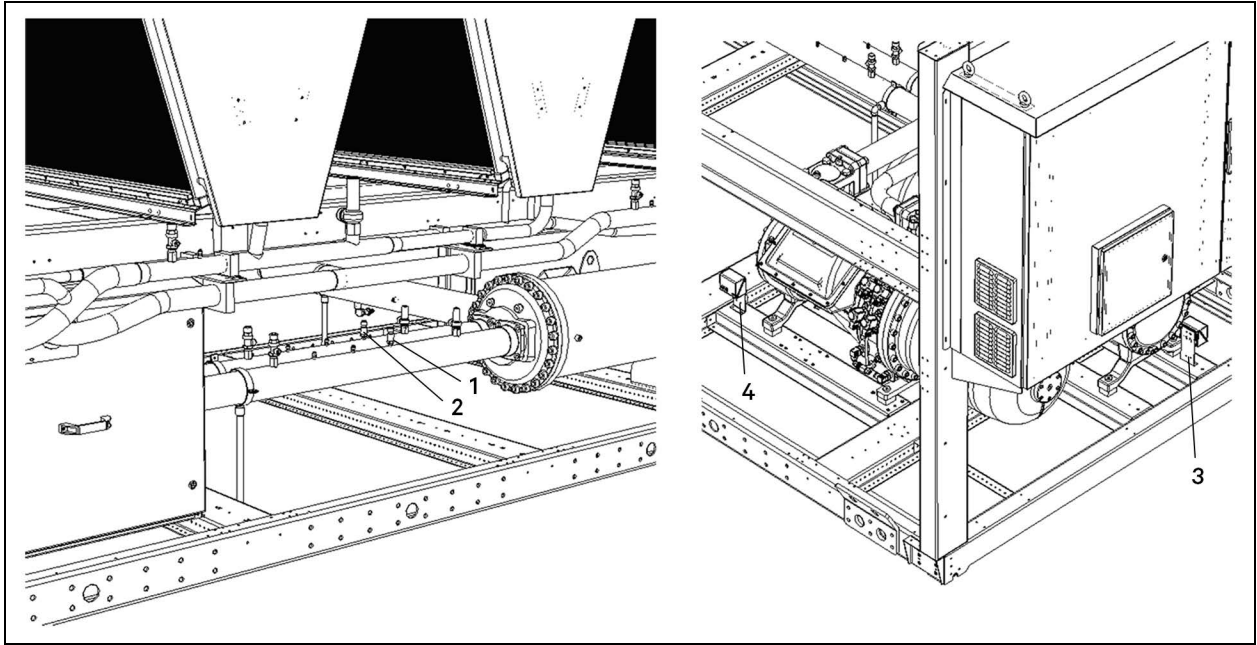

Item	Description
1	Pressure transducer low pressure circuit 1
2	Pressure transducer low pressure circuit 2
3	Low pressure switch circuit 1
4	Low pressure switch circuit 2

Figure 3.9 Typical Sensor Locations

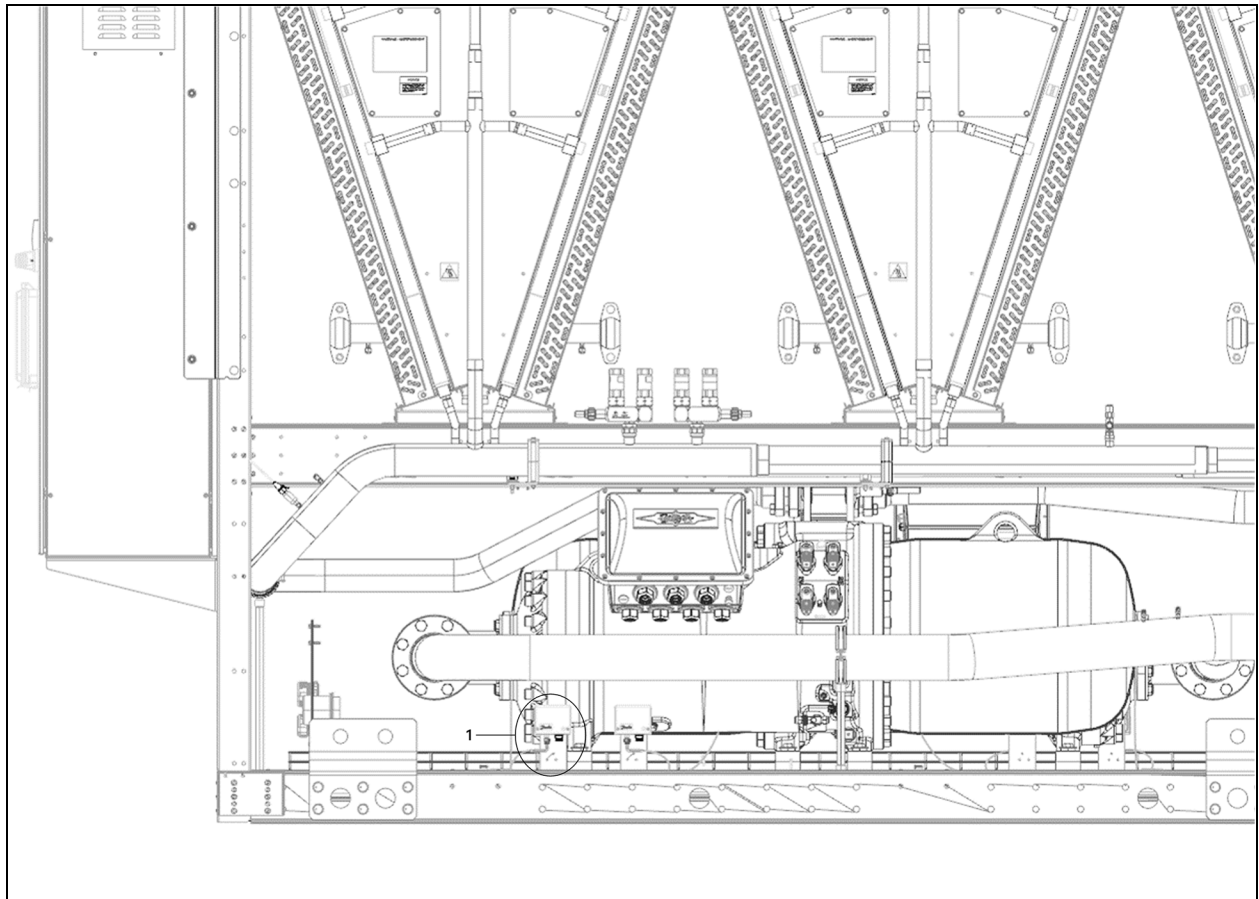
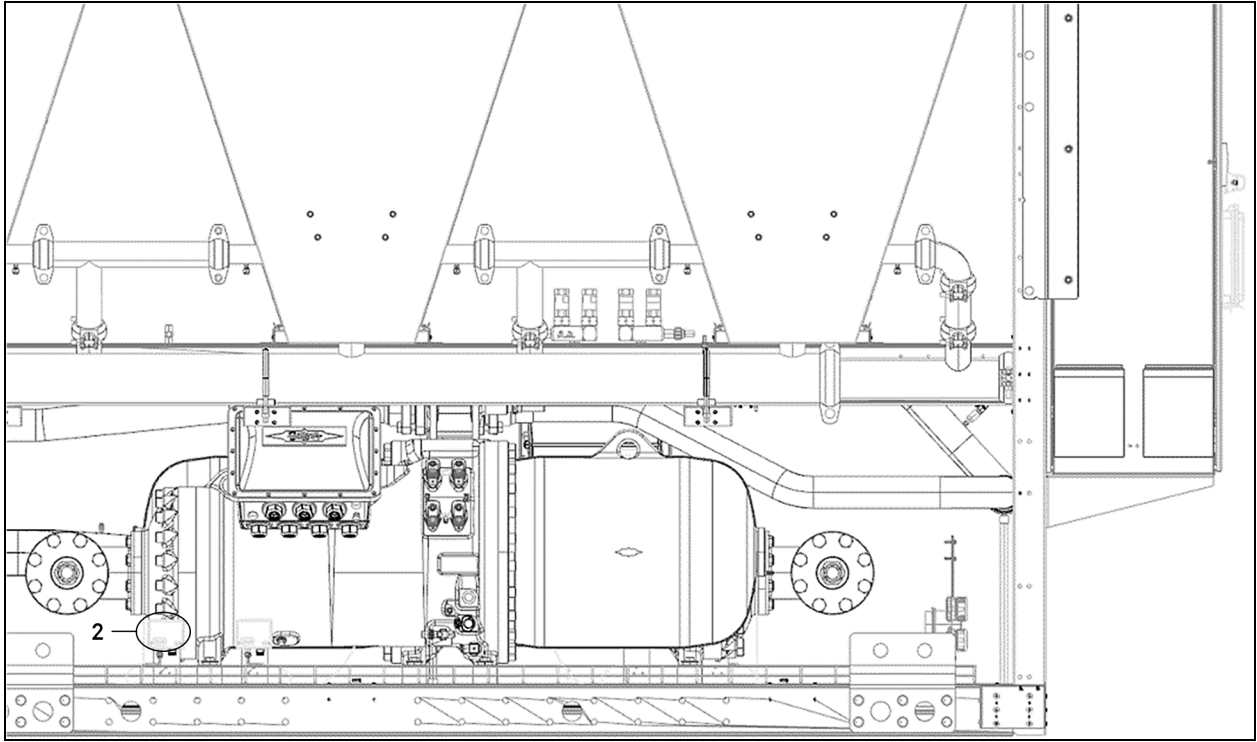
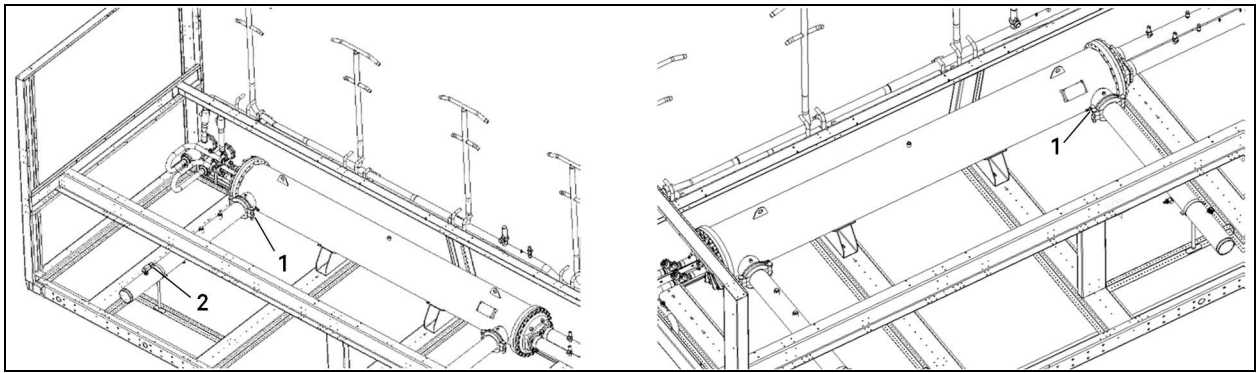

Figure 3.10 Typical Sensor Locations



Item	Description
1	Low pressure switch circuit 1 (only for R1234ze model)
2	Low pressure switch circuit 2 (only for R1234ze model)

Figure 3.11 Typical Sensor Locations



Item	Description
1	Temperature sensors (NTC)
2	Flow switch

Figure 3.12 Typical Sensor Locations

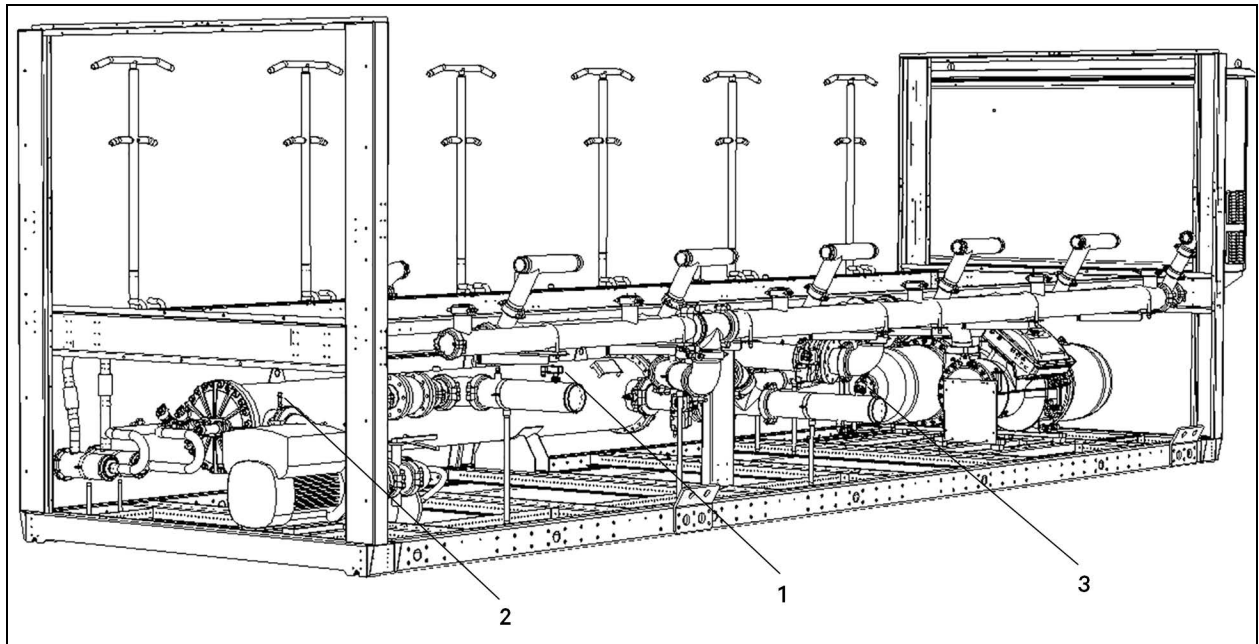

Item	Description
1	Flow switch
2	Anti-vacuum pressure transducer (only with user pump)
3	Flow meter (optional)

Figure 3.13 Typical Sensor Locations

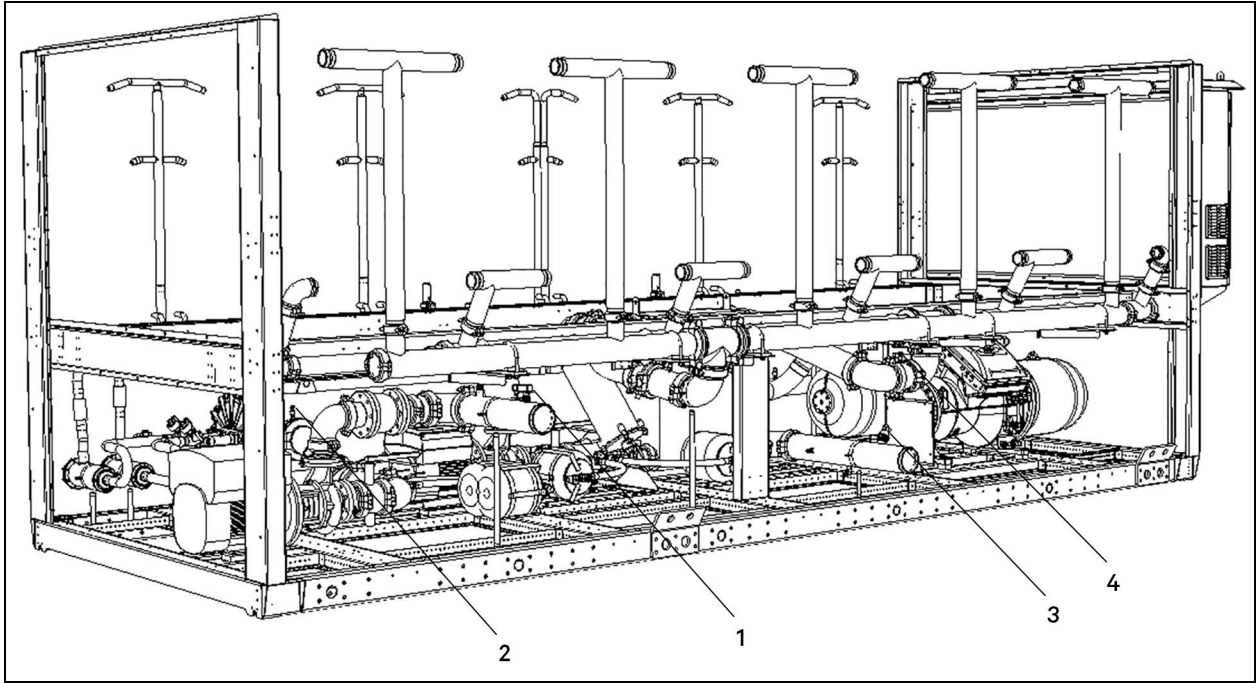

Item	Description
1	Flow switch
2	Anti-vacuum pressure transducer (only with user pump)
3	Flow meter (optional)
4	Pressure transducers (only with microchannel FC coils)

3.3 Control System

3.3.1 Vertiv™ Liebert® iCOM™

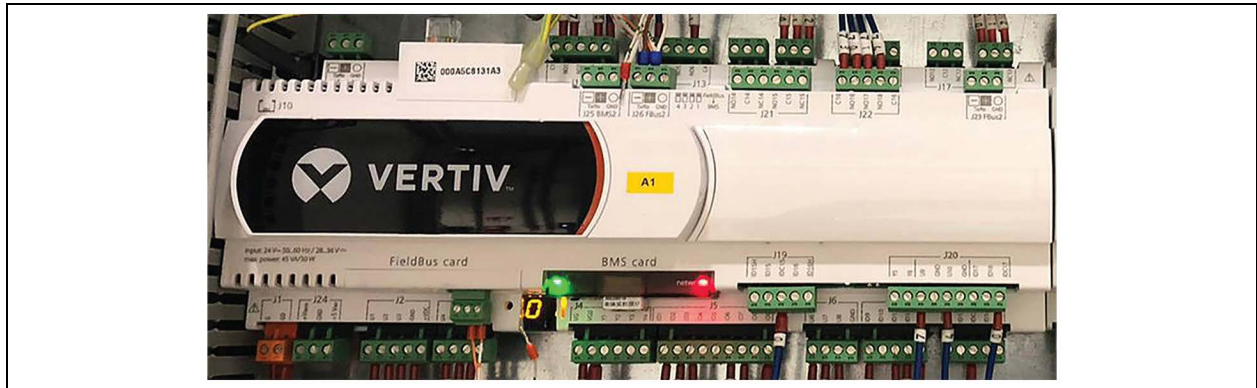

The Vertiv™ Liebert® AFC water chillers are controlled by the Liebert® iCOM™ controller, managing all operational functions and control. The user can change and/or modify the operating parameters through the HMI display keyboard installed on the electrical panel. See the Liebert® AFC iCOM™ V1C Control Application User Guide for details.

NOTE: The Liebert® AFCs are equipped with their own control for the water temperature adjustment. There is a digital input designated for remote ON/OFF control that can be used should the user requires it.

3.4 Capacity and Efficiency Monitoring (Optional)

Vertiv™ Liebert® AFC can be equipped with the following options:

- Energy meter which provides the reading of the instantaneous consumption of electricity (including the consumption of the pump if this is integrated in the unit).
- Flow meter that provides the flow rate of the chilled water (m/s).

If the water flow meter is included, the control unit is able to process and provide the following information:

- Total capacity (kW)
- Mechanical capacity (kW)
- Free-cooling cooling capacity (kW)

If the water flow meter and energy meter are both included, the unit is able to process and provide the following information:

- EER (including the pump consumption if it is integrated in the unit)
- PPUE (including the pump consumption if it is integrated in the unit)

The estimated capacity depends on the instantaneous measured value of the fluid flow and fluid properties (i.e., water vs. glycol/water).

- EER is the ratio between the instantaneous value of the reading of the total cooling capacity and the total consumption of electricity (in the same time period)
- $pPUE = [1 + (1 / EER)]$

All data and data outputs are calculated as estimates, and are dependent on many factors including but not limited to installation location, ambient conditions, operating conditions, etc. These values should be considered as general approximations of unit performance.

3.5 Integral Pumping (Optional)

All models of the Vertiv™ Liebert® AFC series can be equipped with integral water circulation pumps for a variety of different pumping configurations. The unit can be controlled with constant flow or variable flow depending on the type of pump selected.

The inverter pump can also be regulated according to the variable flow logic managed according to particular algorithms determined by plant requirements; the pump regulates to keep the flow with minimum and maximum limits, ensuring a proper and safe operation of the unit.

The pumps are suitable for operation with ethylene glycol-water mixture up to 35/40% by weight and fluid temperatures down to 40°F (4.5°C). The pumps are centrifugal type, with two-pole electric motor with IP54 protection, Class F insulation and at least IE3 efficiency class.

3.6 Integral Hydraulic Kit (Optional)

All models of the Vertiv™ Liebert® AFC series can be equipped with an integral hydraulic kit which includes an expansion tank, valving, and other necessary closed loop components.

It is recommended to always confirm the total capacity of the expansion tank is adequate based on the percentage of glycol in the mixture, the expected maximum temperature variation of the mixture and the total hydraulic volume resulting from the sum of the internal volume of the unit with the volume of the user circuit.

4 Pre-installation Preparation and Guidelines

4.1 Installation



WARNING! Only authorized personnel are allowed to perform installation operations.

All work on internal piping or components of the refrigeration circuit must be exclusively performed by qualified staff.

The authorized personnel must be properly trained and qualified, wear appropriate personal protective equipment and use adequate tools.



WARNING! Unit contains potentially lethal voltage in some circuits. Risk of arc flash and electric shock. Can cause injury or death.

Open all local and remote unit electric power disconnect switches, verify with a voltmeter that power is OFF and wear protective equipment per local standards before working within the electric control enclosure.

It is forbidden to operate on the electrical components without using insulating platforms, or in the presence of water and humidity.



WARNING! The electric enclosures and some components can retain a stored high-voltage electrical charge for up to 10 minutes.

Risk of electric shock. Can cause serious injury or death.

Before working on any electrical systems, proceed as follows:

Open all local and remote unit electric power disconnect switches.

Wait 10 minutes.

Verify with a voltmeter that power is OFF.



WARNING! Only properly trained and qualified personnel may perform repair, maintenance, and cleaning.



WARNING! Before any intervention on the electrical system or accessing the inner components:

Lock the disconnection devices by a padlock or similar tool.

Ensure power is disconnected and apply safety or high voltage warning plate on disconnect switch.



CAUTION: After installation, always close the unit by refitting the relevant panels, if present, fastened by screws.



CAUTION: Sharp edges, splinters, and exposed fasteners. Wear protective gloves before operating on the unit.

NOTICE

Improper handling can cause product damage.

The refrigerant R1234ze falls into refrigerant safety group A2L in accordance to ASHRAE 34.

The Vertiv™ Liebert® AFC liquid chillers are classified as “indirect vented closed system” according ASHRAE 15 and are designated to be installed in a location class III (open air) with occupancy access category Class C (as per ASHRAE 15) where only authorized personnel have access; with these limits for both A1 and A2L refrigerant gas there aren’t any charge restrictions. This limitation must be managed by the customer.

Please refer to the above mentioned standards for further details.

The A2L chiller(s) should be installed away from medium-high voltage power lines in accordance with local safety regulations.

The A2L chiller(s) should be at least 16.4 ft. (5 m) from drains and manholes and should be in an area with free airflow.

During installation, the risk that any gas leaks, being heavier than air, will create pockets in compartments, rooms, chambers, tunnels or other spaces below the level of the machine must be taken into consideration.

To prevent the risk of a thermal event, safety distances must be maintained from any opening in which gas may enter as a result of a leak from the various points of the machine.

4.2 Site Preparation

NOTICE

Vertiv takes no responsibility for systems not compliant with the specifications given in this manual. Lack of compliance to the specifications given by Vertiv voids the warranty.

The customer is responsible for the following operations.

Operation	See
Prepare the area	Location on page 36 and Space Requirements on page 37
Prepare the water system	Water System Specifications on page 53
Prepare the electric system	Electric System Specifications on page 46

Prepare the site for installation prior to arrival and unloading of the unit.

- If installing the unit on a concrete slab or housekeeping pad, sweep the concrete clean and mark the final position of the unit(s) on the slab.
- Verify that all required clearances as specified by Vertiv are met.
- Mark the direction of the final unit placement to avoid accidental reversal of the unit.
- Protect stub outs for electric conduit and any other projections against damage and clearly mark their locations.
- Locate and mark the high point on the slab. This step is critical for the placement of multiple, joined units. See **Figure 4.1** on the facing page .
- If installing on a structural steel support structure, verify suitability of the supports beneath the unit(s).

Figure 4.1 Unit and High Point Marking on Concrete Slab

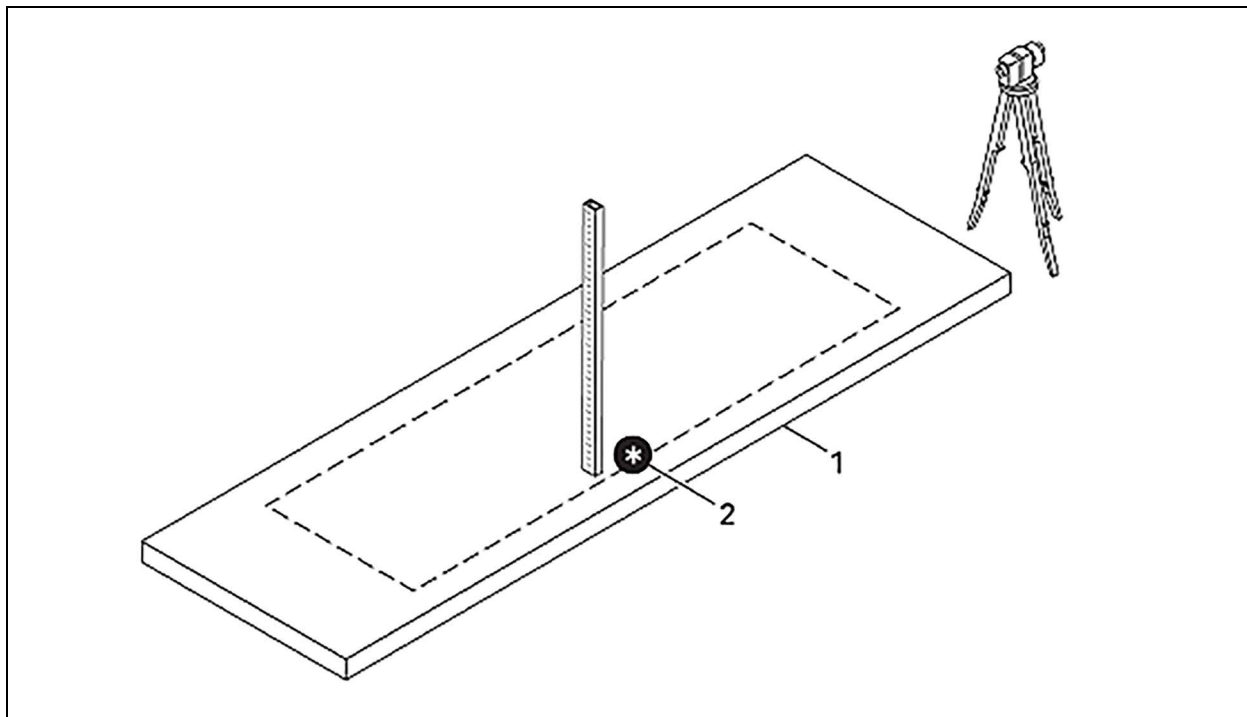

Item	Description
1	Concrete slab
2	High point

4.2.1 Foundations and Positioning

- The unit must be placed on a level surface which supports its weight.
- If necessary, place the unit on suitable type anti-vibration mounts.



CAUTION: Place the anti-vibration mounts on the ground, lower the unit onto them and fix the anti-vibration mounts to the unit itself.

4.2.2 Unit Preparation

The unit is delivered fully assembled at the factory.

Before shipment each unit is tested under standard operating conditions and charged with the right quantity of refrigerant and oil. Operational or environmental conditions on field that differ significantly from standard ones may require charge adjustment. The heat exchangers (evaporator and water coils) are supplied dry, with open drain plugs and exhaust valves, to avoid possible problems due to the frost in the storage period.

The following operations must be done on the Vertiv™ Liebert® AFC unit at the installation site:

Operation	See
1. Position the unit at the final location and fix it on the floor or the supporting structure.	Foundations and Positioning on the previous page
2. Connect the water system to the unit.	Field Piping Connections on page 57
3. Connect the electric power supply.	Connections on page 48 Electrical Power Supply on page 48
4. Connect the electric equipment to the electric box (optional connections).	Connections on page 48 Ethernet Cable Connection on page 49
5. Connect the discharge of the safety valves.	Connections on page 48
6. Fill the water system.	Filling the Chilled Water System on page 56
7. Check the system.	Checklist for Completed Installation on page 59
8. Start the unit for the first time.	Operation on page 61
9. Check or set up the operating parameters of the control system.	Vertiv™ Liebert® AFC iCOM™ V1C Control Application User Guide

4.2.3 Location

- The Vertiv™ Liebert® AFC units must be installed outdoors.
- Prepare a level surface suitable to support the weight of the Liebert® AFC unit.
- The unit produces heat. The installation site must have a good air flow, to guarantee heat dispersion even in the most demanding operating conditions.
- Install the unit in an area with clean air, away from loose dirt and foreign matter.

4.2.4 Space Requirements

- To allow the free passage of air flow and adequate space for maintenance, it is necessary to leave a minimum area around the chiller free of obstructions.
- The hot air expelled by the fans must not be obstructed for a height of at least 8.5 ft. (2.5 m).
- Avoid hot air recirculation phenomena between air suction (sides of unit) and air discharge (through top of unit), as this may result in a reduction in unit performance or potentially lead unit failure.

Figure 4.2 Unit Dimensions

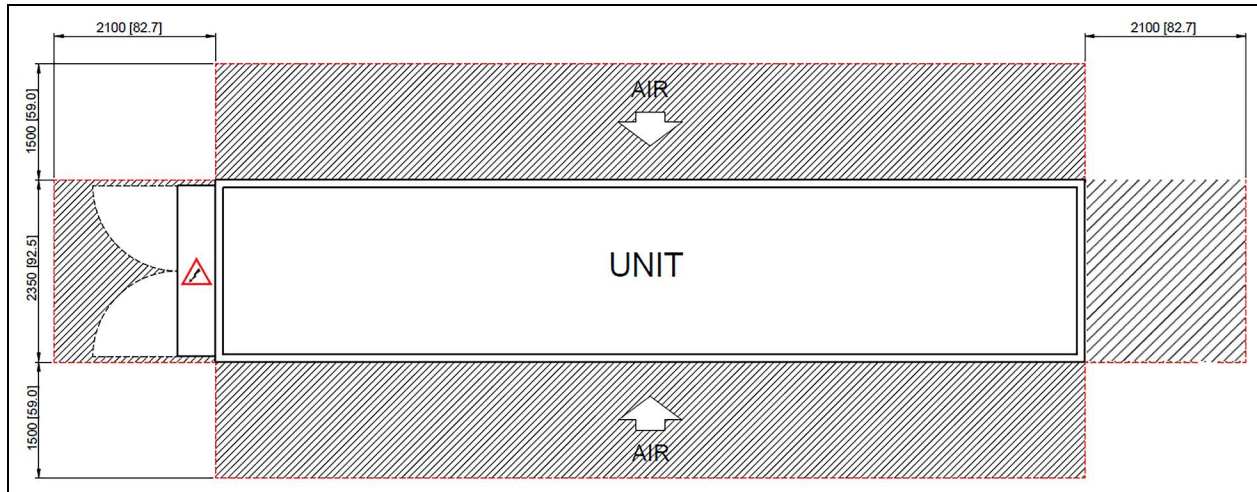

- See [Dimensions and Weights](#) on the next page for the unit dimensions.
- Keep free space between the unit and any obstacle as shown in **Figure 4.2** above.
- Avoid hot air recirculation phenomena between suction and delivery, under penalty of loss of unit performance or even interruption of normal operation.
- The installation location must permit easy access for maintenance operations.

NOTICE

The floor level in the maintenance area on the electrical panel side must be aligned with the surface where the unit is placed, ensuring easy and safe access to the electrical panel, complying with applicable safety regulations.

4.3 Dimensions and Weights

Table 4.1 FH3 Weights

FH3	090	105	120	135	145	160	175
Fans	12	14	16	16	18	18	20
Shipping Weight	19,600	22,400	25,200	25,200	28,900	29,000	30,750
NOTE: Consult the factory for Unit Operation weight.							

Table 4.2 CH3 Weights

CH3	090	105	120	135	145	160	175
Fans	12	14	16	16	18	18	20
Shipping Weight			21,250	21,250	23,500	23,500	25,750
NOTE: Consult the factory for Unit Operation weight.							



CAUTION: The operation weights refer to the base version of the unit; the weight of unit options like user pump groups can be considered as equally distributed on supports and must be added to the total unit weight.

5 Equipment Inspection and Handling



WARNING! Improper handling can cause injury or death. Only authorized personnel are allowed to move, lift, remove packaging from or prepare the unit for installation. The authorized personnel must be properly trained and qualified, wear appropriate personal protective equipment, and use adequate moving equipment (cranes, forklift, etc.).



WARNING! Make sure to use transport and lifting equipment rated for the unit dimensions and weight. See [Dimensions and Weights](#) on page 38 .



WARNING! Never walk or stay below a suspended load.



WARNING! The free-cooling coil sections are supplied dry or charged with the right % of glycol to avoid possible problems due to frost during the storage period.



CAUTION: Sharp edges, splinters, and exposed fasteners. Wear protective gloves before operating on the unit.

NOTICE

Improper handling can cause product damage.

5.1 Inspection

- After receiving the product, check the accessories against the packing list.
- If any parts are found missing or damaged, please report to the carrier immediately.
- If you find any damage, please report to the carrier and to the local distributor.
- Unpacking: dispose of the packaging products by transferring them to specialized collection or recycling centers (follow the local regulations in force).



WARNING! In the case of closed trucks, the compartment containing the unit must be opened without possible ignition sources nearby and ensuring adequate subsequent ventilation before any further operation.

Upon receipt of the unit, a leak detector with a sensitivity of not less than 3 g/year must be used to check the most critical areas of the refrigeration circuit that may have suffered damage during transport or handling (in particular the area inside the compressor box): this operation must be done in a well-ventilated environment and free from potential sources of ignition.

Special boxes for marine transport have dedicated indications for unpacking and disposal; when unpacking there is a residual risk of releasing a flammable air mixture: this operation must be done in a well-ventilated environment and free from potential sources of ignition.

5.2 Removing the Unit Using a Crane

Figure 5.1 Lifting Instructions with Four Brackets (12 fans)

LIFTING WITH BELT SLINGS

LIFTING SPREADER BAR (NOT SUPPLIED)
BELT SLING (NOT SUPPLIED)

"A"
"B"
E

LIFTING WITH ROPE SLINGS

ROPE SLING (NOT SUPPLIED)

"C"
E

USE POSITION HOLE LIFTING ON BRACKET MARKED ON BASE

BELT OR ROPE SLING (NOT SUPPLIED)

STRAIGHT SHACKLE (NOT SUPPLIED)

LIFTING BRACKET ON BASE UNIT

PART. E

RIGID STRUTS POSSIBLY STEEL (NOT SUPPLIED)

PROTECTION PLANK (NOT SUPPLIED)

ROPE SLING (NOT SUPPLIED)

PART. F

Models	Fans n.	A	B	C
		in (mm)	in (mm)	in (mm)
FV/NV/CI FH/NH/CH	12	~110 [2800]	~197 [5000]	~394 [10000]

The lifting capacity of lifting devices must be adequate to the load.
Check the weight of the units, the capacity of the spreader bar and ropes, the condition and suitability of the aforementioned equipments.
Lift the unit with a speed suitable for the load to be moved, in order to not damage the unit structure.
After lifting and positioning, remove lifting accessories (ropes, belts, chains, hooks, brackets).
Lifting tools as hooks, spreader bar, ropes, straps, rigid struts, protection plank are not provided with the unit.

1. Insert a sling in each of the iron beams.
2. Use a crane to move the unit.

NOTICE

Do not use a forklift to move the unit. The structure does not support heavy loads and would be damaged.

NOTICE

Lift the unit with a speed suitable for the load to be moved, so as not to damage the structure.

- If the unit is shipped with a container, for extraction, follow the instructions on the front panel.
- Move the unit by lifting it from above with a crane.
- The holes for lifting are positioned on special yellow brackets fixed to the base frame (when lifting, use spreader bars to protect the side).

The lifting capacity of the lifting parts must be adequate for the load to be lifted. Check the weight of the units, the capacity of the sling bar and the ropes, the validity and the conditions of the aforementioned equipment. Do not tilt the unit more than 15°. No force or effort must be applied to pressurized parts, especially via pipes connected to the condensers or to the evaporator.

Figure 5.2 Lifting Baricentric Axis with Four Brackets

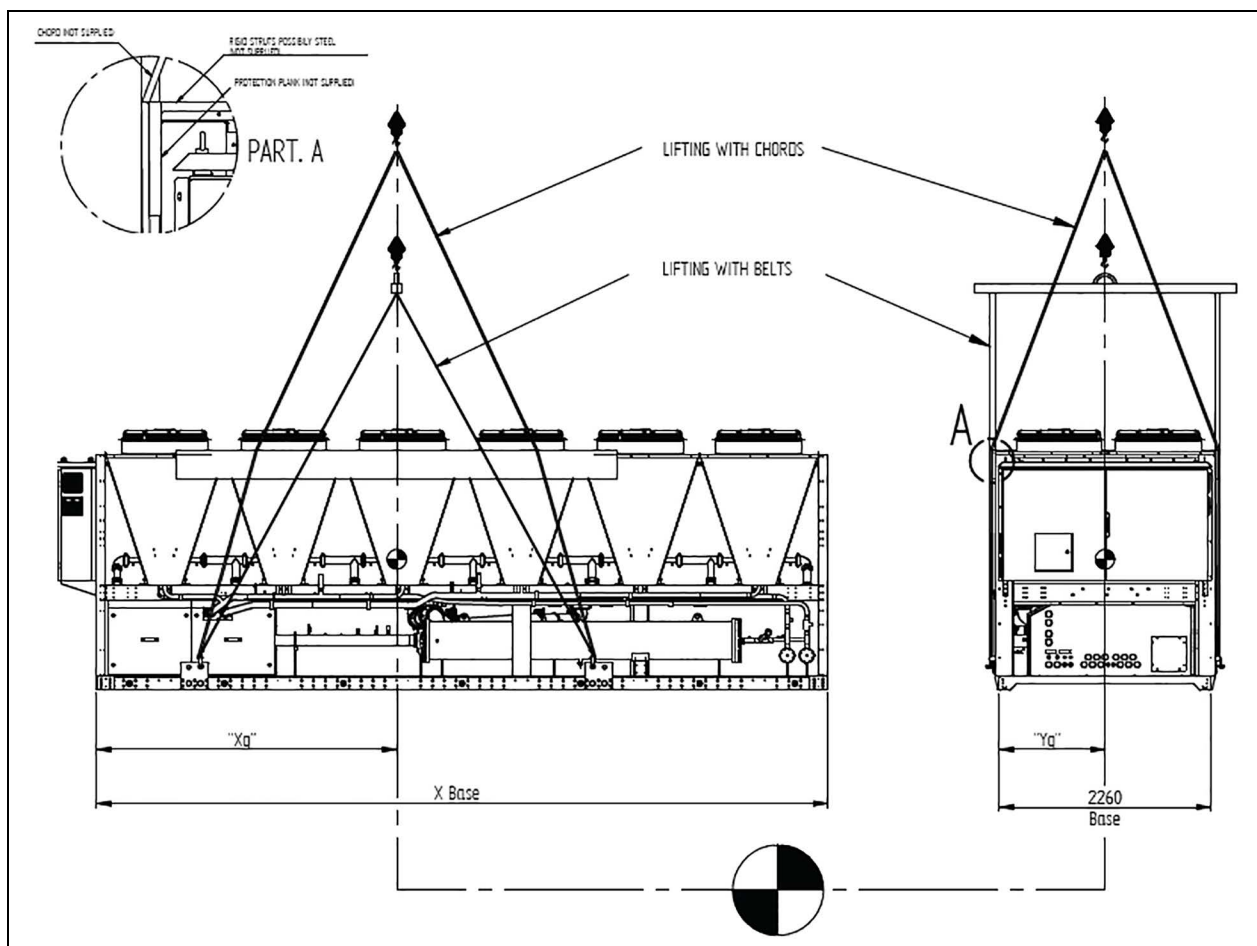

N.B: The lifting point has to be on the vertical baricentric axis, which is individualized by symbols indicated on the base.

Do not tilt the unit more than 15°.

No force must be applied to pressurized parts, especially pipes.

! WARNING! The lifting point must be aligned with the gravity center.

- Refer to [Dimensions and Weights](#) on page 38 for dimensions, weight, and gravity center position.
- If the unit is still packaged, pay attention to the gravity center and warning labels placed on the unit.

Figure 5.3 Lifting Instructions with Eight Brackets (14-20 fans)

LIFTING WITH BELTS

LIFTING SLING BAR NOT SUPPLIED
BELT NOT SUPPLIED

LIFTING WITH CHORDS

CHORD NOT SUPPLIED

USE POSITION HOLE LIFTING ON BRACKET MARKED ON BASE

BELT OR CHORD NOT SUPPLIED

STRAIGHT SHACKLE NOT SUPPLIED

BRACKET LIFTING ON BASE UNIT

PROTECTION PLANK NOT SUPPLIED

RIGID STRUTS POSSIBLY STEEL NOT SUPPLIED

CHORD NOT SUPPLIED

PART. E

PART. F

The capacity of the lifting gear must be adequate to lift the load in question.
Check the weight of the units, the capacity of the lifting gear and ropes and the condition and suitability of the aforementioned equipment.
Lift the unit with a speed suitable for the load to be moved, so as not to damage the structure unit.
After lifting and positioning the unit, remove lifting accessories (ropes, slings, chains, hooks, brackets).
Lifting tools as hooks, lifting gear, ropes, chords, belts, rigid struts, protection plank are not provided with the unit.

Models	Fans n.	A	B	C
		in [mm]	in [mm]	in [mm]
FH/NI/CI FH/NH/CH	14-20	~110 [2800]	~197 [5000]	~394 [10000]

1. Insert a sling in each of the iron beams.
2. Use a crane to move the unit.

NOTICE

Do not use a forklift to move the unit. The structure does not support heavy loads and would be damaged.

NOTICE

Lift the unit with a speed suitable for the load to be moved, so as not to damage the structure.

- If the unit is shipped with a container, for extraction, follow the instructions on the front panel.
- Move the unit by lifting it from above with a crane.
- The holes for lifting are positioned on special yellow brackets fixed to the base frame (when lifting, use spreader bars to protect the side).

The lifting capacity of the lifting parts must be adequate for the load to be lifted. Check the weight of the units, the capacity of the sling bar and the ropes, the validity and the conditions of the aforementioned equipment.

Do not tilt the unit more than 15°.

No force or effort must be applied to pressurized parts, especially via pipes connected to the condensers or to the evaporator.

Figure 5.4 Lifting Baricentric Axis with Eight Brackets

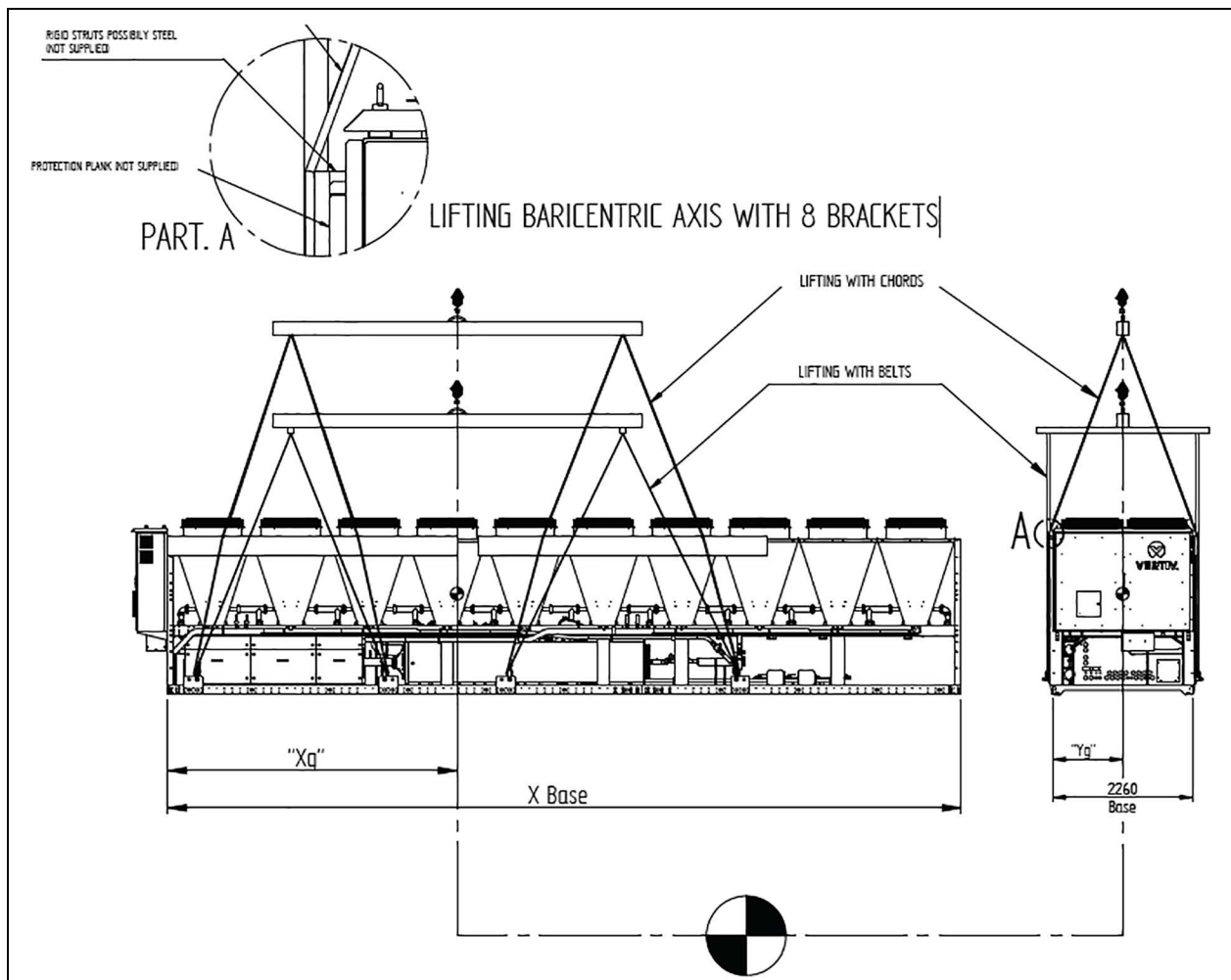

N.B: The lifting point has to be on the vertical baricentric axis, which is individualized by symbols indicated on the base.

Do not tilt the unit more than 15°.

No force must be applied to pressurized parts, especially pipes connected to the condensers or to evaporator.



WARNING! The lifting point must be aligned with the gravity center.

- Make reference to [Dimensions and Weights](#) on page 38 for dimensions and weight.
- If the unit is still packaged, pay attention to the gravity center and warning labels placed on the unit.

6 Electrical Connections



WARNING! Arc flash and electric shock hazard. Can cause serious injury or death. Building and equipment damage may also result. Disconnect all local and remote electric power supplies and wear appropriate, OSHA-approved personal protective equipment (PPE) per NFPA 70E before working within the electric control enclosure. Customer must provide earth ground to unit, per NEC, CEC, and local codes, as applicable.

Verify with a voltmeter that power is Off. The Vertiv™ Liebert® iCOM™ controller does not isolate power from the unit, even in the “Unit Off” mode. Some internal components still require and receive power even during the “Unit Off” mode of the Liebert® iCOM™ controller. The factory-supplied, optional disconnect switch is inside the unit. The line side of this switch contains live high voltage. The only way to ensure that there is NO voltage inside the unit is to install and open a remote disconnect switch. Refer to unit electrical schematic.

Before proceeding with installation, read all instructions, verify that all the parts are included and check the nameplate to be sure the voltage matches available utility power. Follow all local codes.



WARNING! Risk of electric shock. Can cause serious injury or death. Building and equipment damage may also result. Open all local and remote electric power supply disconnect switches and verify that power is off with a voltmeter before working within any electric connection enclosures. The Liebert® iCOM™ controller does not isolate power from the unit, even in the "Unit Off" mode. Some internal components require and receive power even during the "unit off" mode of the Liebert® iCOM™ controller.

Installation, service, and maintenance work must be performed only by properly trained and qualified personnel and in accordance with applicable regulations and manufacturers' specifications. Opening or removing the covers to any equipment may expose personnel to lethal voltages within the unit even when it is apparently not operating and the input wiring is disconnected from the electrical source.



WARNING! Risk of short circuits and electric shock. Can cause serious injury or death. Building and equipment damage can result from cut insulation or damaged wires. Can cause overheated wiring, smoke, fire, activation of fire suppression systems and EMS personnel, and loss of power to fans. Verify that all wiring connections are tight and that all wiring is contained within the junction box prior to closing and securing the cover.

Insert CSA certified or UL listed bushings into holes and/or knockouts used to route wiring through metal panels to protect the wire insulation from contact with sheet metal edges.



WARNING! Risk of improper wire sizing/rating and loose electrical connections causing overheated wire and electrical connection terminals resulting in smoke or fire. Can cause serious injury or death. Building and equipment damage may also result. Use correctly sized copper wire only and verify that all electrical connections are tight before turning power On. Check all electrical connections periodically and tighten as necessary.

Figure 6.1 Wiring Connections

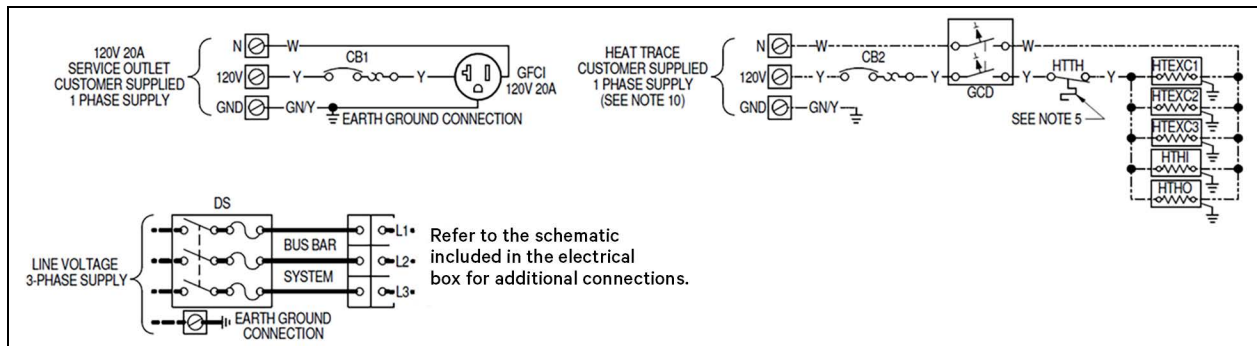

6.1 Electric System Specifications

6.1.1 Power Supply

- Check the electrical data on the label applied on the unit.
- Check that the available power supply is consistent with unit power requirements.
- Refer to the electrical schematic supplied with the unit when making line voltage supply, low voltage main unit interlock, and any low voltage alarm connections.

6.1.2 Local Codes

- Electrical service must conform to national and local electrical codes.
- All wiring must be done in accordance with all applicable local, state, and national electrical codes.

6.1.3 Power Supply Variability

- Check the phase imbalance.
- Make sure to comply with the following data:
 - Electrical voltage supply between 0.9 and 1.1 nominal voltage
 - Frequency between 0.99 and 1.01 the nominal frequency
 - Variability of supply voltage less than 2%

6.1.4 Power Supply Connection

- A 3-phase, 460 V power supply to the unit electrical enclosure.
- A separate 120 V power feed to the utility box (for convenience outlet)
- An optional, separate 120 V power feed for heat trace (low ambient option) controls.

The electrical connections are described in the submittal documents included in the [Submittal Drawings](#) on page 79 . The low voltage connections are further detailed in **Figure 6.2** on the facing page .

The following table lists the relevant documents by number and title.

Table 6.1 Electrical Field Connection Drawings

Document Number	Title
DPN005148	Electrical Field Connections

Figure 6.2 BMS Communication Connection and Network Connection

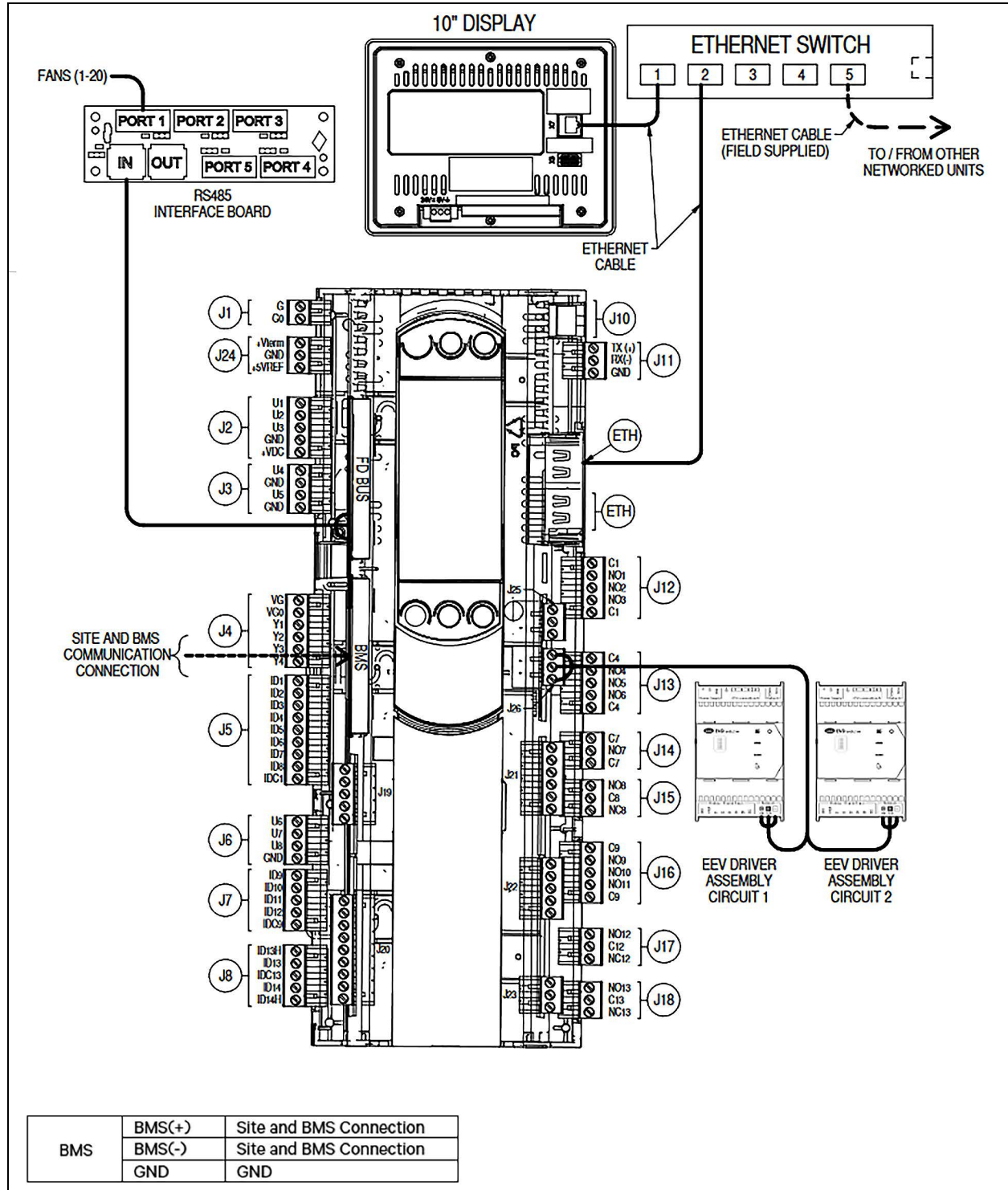

6.2 Connections

6.2.1 Electrical Power Supply

Refer to the Electrical Connection drawing listed in [Submittal Drawings](#) on page 79 .

Figure 6.3 Electrical Power Supply

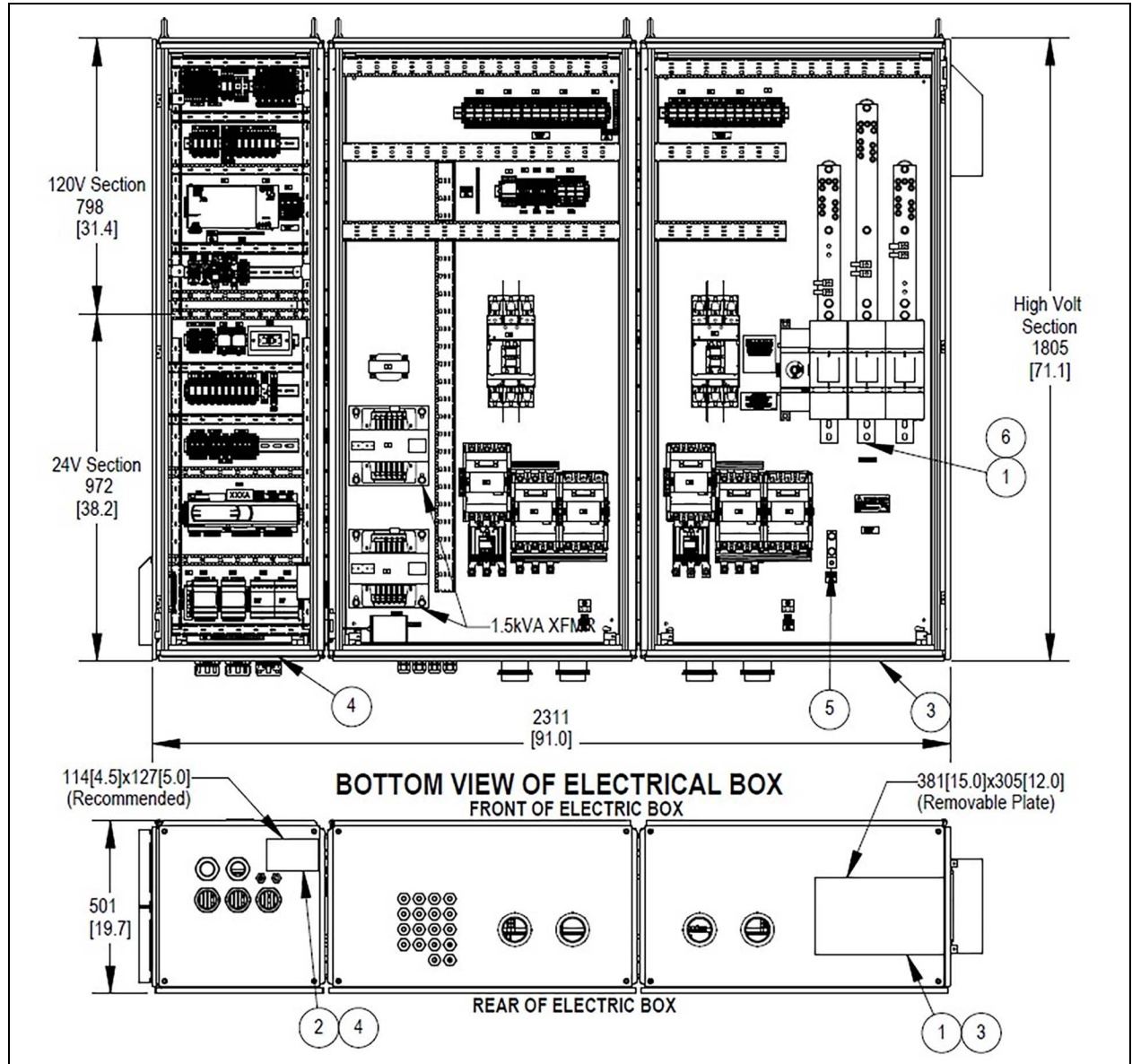

Item	Description
1	Power supply
2	Low voltage connection for the control system
3	Passage for cables
4	Protective earth connection

6.2.2 Ethernet Cable Connection

Refer to DPN005148 included in [Submittal Drawings](#) on page 79 .

- Fasten the cable to the clamp-holding plates and make it pass through the first free hole on the panel bottom (arrange a cable clamp).
- After opening the pre-cut knockout in the control panel opposite the supply line inlet, restore the original protection degree with suitable accessories for the wiring and junction boxes.

The cable must be protected by a sheath.

6.3 Electric Box and Main Switch

Figure 6.4 Electric Box



Item	Description
1	Main switch secondary power supply (control and auxiliary systems)
2	Main switch - This is a disconnecting switch and cuts off the electric power supply to the whole unit.
3	Touch screen panel See the Vertiv™ Liebert® iCOM™ 3 User Manual for details.

6.4 Electrical Service Entrances

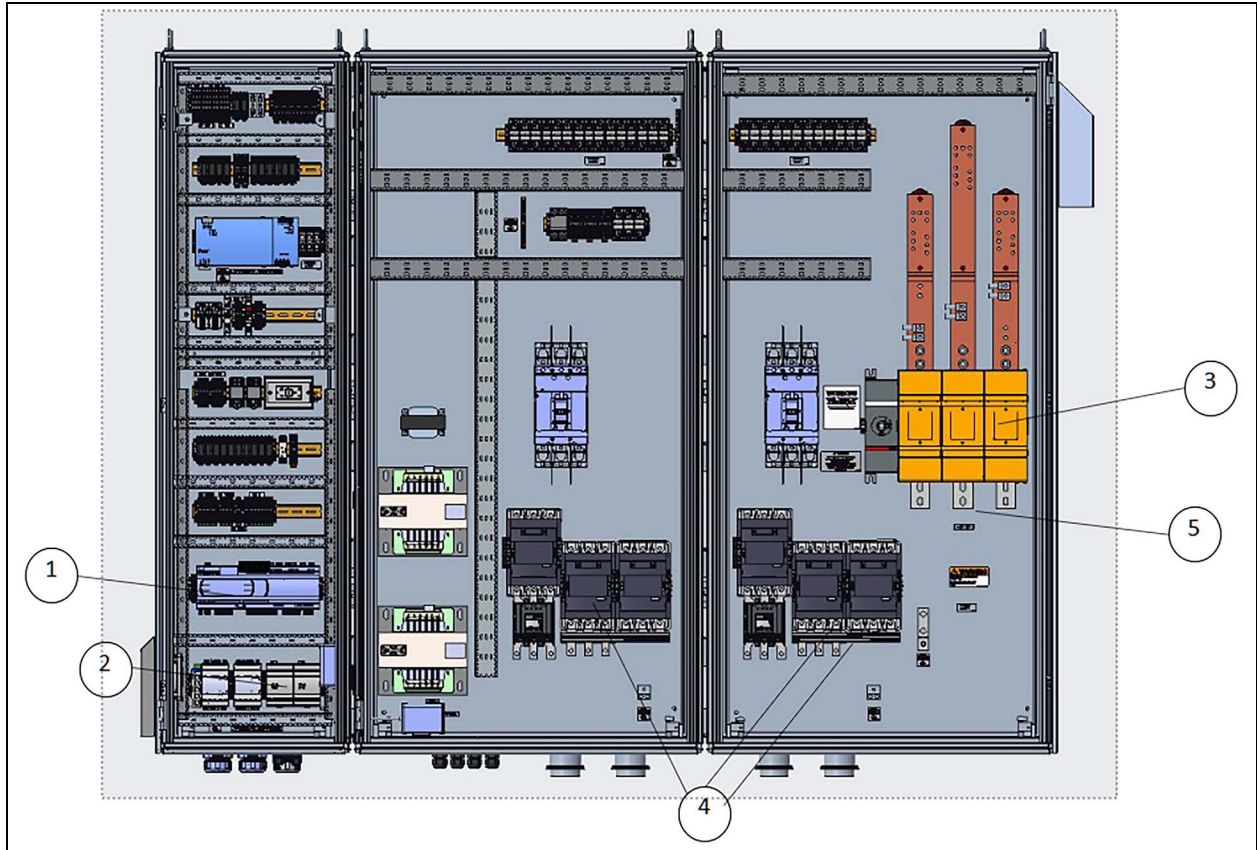

Item	Description
1	Control board
2	Buffer Module (Ultra-capacitor)
3	Fuse holder for compressors
4	Compressor contactors
5	Three-phase electrical connection

This page intentionally left blank

7 Piping Requirements



WARNING! Risk of improper wiring, piping, moving, lifting and handling. Can cause serious injury or death. Building and equipment damage may also result. Installation and service of this equipment should be done only by qualified personnel who have been specially-trained in the installation of air-conditioning equipment and who are wearing appropriate, OSHA-approved PPE.

Field-installed piping must be installed in accordance with local codes and must be properly assembled, supported, isolated and insulated. Avoid piping runs through noise-sensitive areas, such as office walls and conference rooms.

7.1 Refrigerant Charge Requirements

Table 7.1 Refrigerant System - Models CH3 and FH3 (Fixed Speed Compressors with R513A)

Model	*H3 090	*H3 105	*H3 120	*H3 135	*H3 145	*H3 160	*H3 175
Number of refrigerant circuits	2	2	2	2	2	2	2
Refrigerant charge R513A (C1/C2) lbs [kg]	130/117 [59/53]	148/137 [67/62]	183/159 [83/72]	196/137 [89/62]	196/176 [89/80]	196/176 [89/80]	216/196 [98/89]
Oil charge (C1/C2) fl oz [dm ³]	634/634 [18.7/18.7]	634/634 [18.7/18.7]	1021/1021 [30.2/30.2]	1021/1021 [30.2/30.2]	1021/1021 [30.2/30.2]	1021/1021 [30.2/30.2]	1021/1021 [30.2/30.2]
For proper oil level, each compressor has an oil sight glass, use this sight glass as reference for proper oil charge.							

7.2 Water System Specifications

7.2.1 System Protection

Flow Switch

Normal operation:

1. The water pumps start.
2. There is water flow in the system.
3. The compressors start.
4. The compressors operate only if there is enough water flow in the system.

In case of pump failure:

- The compressors will not start if there is no water flow in the system.
- The Vertiv™ Liebert® AFC has factory mounted protections (flow switch) in case of lack of water flow in the evaporator.
- The Liebert® AFC has a protection in case of lack of sufficient water pressure if pump(s) group is installed on board: this is to avoid pump's cavitation and or depressurization of the chiller hydraulic circuit.
- The Liebert® AFC has a protection for variable flow systems: it's monitored and controlled the min e max flow and its gradient (< 10% by minute).

Max. Hydraulic Operating Pressure

The maximum hydraulic operating pressure of the Liebert® AFC is 150 psi (10 bar).

- Check the maximum pump static head (Pp) (indicated on pump’s nameplate).
- Check the static head of the water circuit (Pw).
- Make sure that it is always: $Pp + Pw < 150 \text{ psi (10 bar)}$.

7.2.2 Chilled Water Treatment

Water Analysis and Treatment

It is the user’s responsibility to establish the quality of the water and make sure that this is compatible with the materials used in the exchangers. The quality of water may significantly affect the operation and the life of the exchangers. The first step in planning the treatment of water is chemical analysis, which must be performed by qualified personnel from specialist organizations.

Corrosion Prevention

The oxygen dissolved in water increases the rate of corrosion. The main factors causing corrosion are sulfur and carbon dioxide acids (see the Langelier and Ryznar indices).

A combined effect of fouling due to dust and organic material provides a support for bacteria, fungi and algae; the growth of organisms may produce an oxygen gradient and this results in rather severe pitting of the metallic surface.

The phenomenon of corrosion is obviously related to the material used on the liquid side of the heat exchanger.

Table 7.2 below shows the reference values for corrosion on copper, these values must be considered as guidelines to avoid corrosion.

Table 7.2 Reference Values for Copper Corrosion

pH	---	7.5 - 9.0
SO42-	ppm	< 100
HCO3/SO42-	---	> 10
Total hardness	dH	4.0 - 8.5
Cl-	ppm	< 50
PO43-	ppm	< 2.0
NH3	ppm	< 0.5
Free Chlorine	ppm	< 0.5
Fe3+	ppm	< 0.5
Mn2+	ppm	< 0.05
CO2	ppm	< 10
H2S	ppb	< 50
Oxygen content	ppm	< 0.1
Suspended solids	mg/l	< 1500
Electric conductivity	μS/cm	< 800

7.3 Freeze Protection

7.3.1 Glycol Solutions

In winter, if the system is stopped, the water inside the exchangers can freeze damaging the system irreparably.

Thus, it is recommended to use glycol mixtures.

After filling the hydraulic circuit, check the concentration and add glycol if necessary.

Water-glycol mixtures are used as the thermal carrier fluid in very cold climates or with temperatures below 32°F (0°C).

Determine the percentage of ethylene glycol which must be added to the water, using the following table:

Table 7.3 Ethylene Glycol to be Added to Water (% in weight of total mixture)

Ethylene glycol (% in weight)	0	10	20	30	40
Freezing temperature, °F (°C)	32 (0)	24.1 (-4.4)	14.2 (-9.9)	2.2 (-16.6)	-13.4 (-25.3)
Mixture density at 68°F (20°C) [lb/ft ³]	62.3	63.5	64.5	65.5	66.4
*Values are for Clariant Antifrogen N. For different brands, check manufacturer's data.					

Table 7.4 Propylene Glycol to be Added to Water (% in weight of total mixture)

Propylene glycol (% in weight)	0	10	20	30	40
Freezing Temperature °F (°C)	32 (0)	26.1 (-3.3)	19.2 (-7.1)	9.2 (-12.7)	-6.0 (-21.1)
Mixture density @ 68°F (20°C) [lb/ft ³]	62.3	63	63.7	64.2	64.7
*Values are for Dowfrost heat transfer fluid. Check manufacturer data for other glycol types.					

For the water charges in the Vertiv™ Liebert® AFC circuit refer to [Water System Specifications](#) on page 53.

- To avoid stratification, run the circulation pump for at least 30 minutes after each addition of glycol. If the pumps are installed on board the chiller, they must all be operated simultaneously.
- Flush all parts of the chiller hydraulic circuit including the free cooling coils and the by-pass sections; to do this, manually move the 2-way valves to both positions, making the circuit flush for the necessary time.
- After adding water to the circuit, it is mandatory to disconnect the system from the sanitary water network; this will avoid the danger of the return of glycol water in the same network.

Always load the hydraulic circuit with the correct percentage of glycol required for the minimum ambient temperature of the installation site to prevent a void of warranty.

7.4 Filling the Chilled Water System

Figure 7.1 Filling the Water System

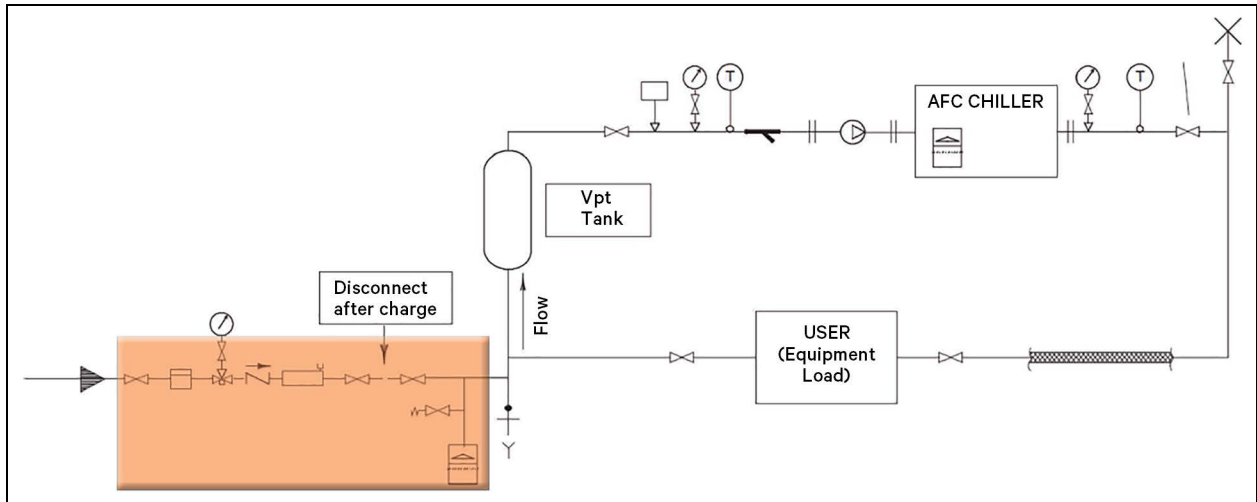

- Supply water through the fill group.

See [Water System Specifications](#) on page 53 for the amount of water to charge.

- In case of low ambient temperature, add glycol. See [Freeze Protection](#) on the previous page .
- To avoid stratification, run the circulation pump for at least 30 minutes after adding any glycol.
- At the end of the filling operation, disconnect the water supply tube.
- After filling, check the concentration of glycol if necessary.

NOTICE

Always charge the hydraulic circuit with the required glycol percentage necessary for the minimum ambient temperature of the installation site. Failing to comply with this instruction shall invalidate the unit warranty.

NOTICE

Do not exceed the nominal operating pressure of the circuit's component.

7.5 Draining

To drain the system completely, use the shut-off valves arranged in the hydraulic circuit and use compressed air to purge any remaining water.

NOTICE

For longer term draining or storage it is recommended to flush the circuit with non-nitrogen anhydrous (N₂) in order to dry it as much as possible after this operation, close the circuit, vents, and drains to make sure that no air returns into it.

7.6 Field Piping Connections

Connect grooved lines with the Victaulic-type joints of the unit, taking care to suitably grease the joint gaskets. Flanged connections are available as an optional feature.

Figure 7.2 Joints

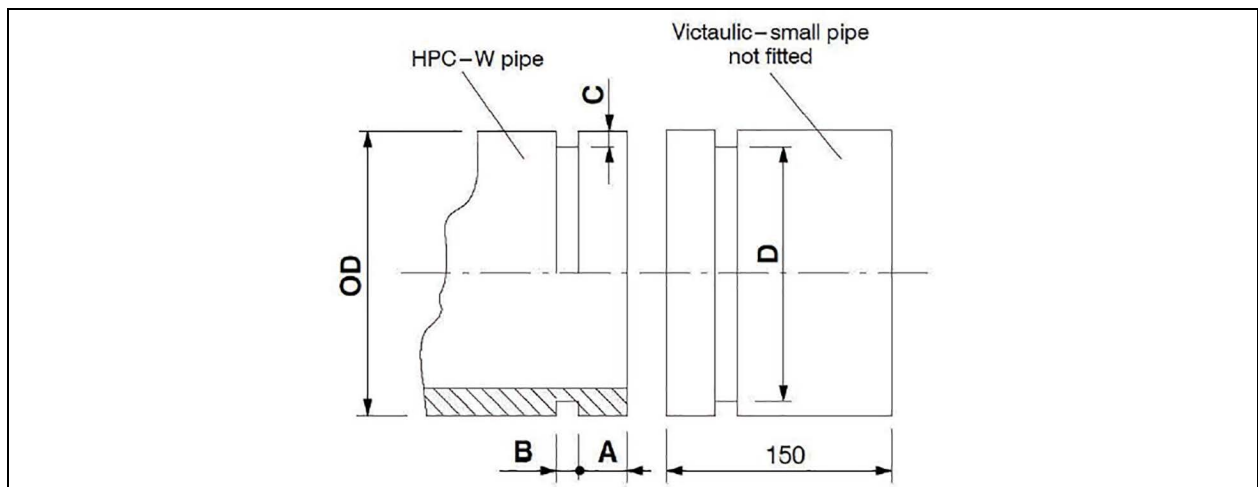

7.6.1 Vibration Damping

Connect the water system piping to the Vertiv™ Liebert® AFC by flexible joints to avoid transmitting vibrations and to balance the thermal expansion.

Use flexible joints also for the pump assembly outside the Liebert® AFC.

Isolate piping from the building using vibration isolating supports.

This page intentionally left blank

8 Checklist for Completed Installation

8.1 Electrical System



WARNING! Disconnect the power supply before doing the following checks on the electric system as explained in [Important Safety Instructions](#) on page 1 .

1. Check all of the cable connections particularly the main power connections on the power fuses and contactors.
2. Check that all of the thermal protections are calibrated according the electrical data tables reported on the wiring diagram.

8.2 Refrigeration System

1. Open the discharge valve (and the suction valve, if installed) of the compressor and the shut-off valve on the liquid line.
2. Open the valves of the refrigerating circuit that had been closed before the initial check.

8.3 Water System

1. Check all water connections.
2. Open all isolating valves and/or water ball valve.
3. In case of climates with temperatures below 32°F (0°C), make sure the chilled water circuit is filled with the correct concentration of water/glycol, see [Freeze Protection](#) on page 55 .
4. Bleed all air out of the chilled water circuit.
5. Verify the water flow rate and its direction.
6. Ensure that the thermal load is sufficient and stable for start-up.
7. Start the pumps, check that they rotate in the correct direction.

8.4 Covers and Seals

1. Make sure that all of the protective covers and seals have been mounted again.

8.5 Flow Switch

Check the flow switch operation.

1. Close the shut-off valve downstream of the evaporator till the flow switch intervenes.
2. Check if, without flow, the flow switch signal changes from CLOSED to OPEN in the Service Control page in the display.
3. Open the shut-off valve downstream of the evaporator.

8.6 Alarms

Make sure that all of the alarms have been reset (see the Vertiv™ Liebert® AFC iCOM™ V1C Control Application User Guide).

8.7 Water Temperature

1. Check the outlet temperature of the chilled water.
2. Check if the setpoint set on the control is reached.

NOTE: Don't exceed inlet temperature of 90°F (32.2°C).

8.8 Compressor

1. Check the compressor oil level. See [Oil Charge](#) on page 73 if you need to top-up the oil.
2. With the compressor at full load, check there are no bubbles visible in the flow indicator. If there are any, charge the unit according to [Refrigerant Charge](#) on page 72.

9 Operation



WARNING! The authorized personnel must be properly trained and qualified, wear appropriate personal protective equipment, and use adequate tools.

NOTICE

The power supply should never be disconnected during normal operation, except when performing maintenance (see [Maintenance](#) on page 69).

9.1 Power Up

1. Close the disconnection device upstream of the Vertiv™ Liebert® AFC.
2. Close the main switch.
3. Set the general knife switch to the position “I”.
 - Check that the Vertiv™ Liebert® iCOM™ display switches ON.
 - Check phase imbalance.

9.2 Unit Start-up

NOTE: Follow these instructions at first start-up and also in case of restart after a long stop.

9.2.1 Compressor Pre-heating and Check

When you set the general knife switch to the position “I”, the compressor oil heaters are automatically powered ON. See [9.1](#) above.

NOTICE

- Remember to power up the unit well in advance before starting the normal operation.
- Make sure the auxiliary circuit has been powered and check the operation.

Pre-heating:

- Check that all the valves for the refrigerating circuit are open.
- Check that the compressor intake pressure is higher than 94.3 psi (6.5 bar) for R513A or higher than 65.3 psi (4.5 bar) for R1234ze.

If this is not the case, prolong the pre-heating of the compressor and check that the refrigerant EEV valve is properly closed.

9.2.2 Water System

- Check the hydraulic system connections and valve positions.
- Start the evaporator pumps.

9.3 Start

To turn the unit to On, press the On/Off button located at the top right side of the Vertiv™ Liebert® iCOM™ interface. The power button will only be enabled if at least one user is logged in. See **Figure 9.2** on the facing page. After a confirmation message the icon will change to green and the UNIT ON status displays.

Figure 9.1 Liebert® iCOM™ HMI Touch Display



Figure 9.2 Liebert® iCOM™ Power Button



Item	Description
1	Power button

9.4 Stop

- To turn off the unit, press the On/Off button located at the top of the Vertiv™ Liebert® iCOM™ interface. See **Figure 9.2** above. The power button will only be enabled if at least one user is logged in.

In case of a short stop:

- Maintain the general knife switch to the position “1” to maintain the supply to the crankcase heater.

In case of a long stop (seasonal shutdown):

- Set the general knife switch to the position “0”.

This will disconnect the compressor crankcase heaters.

- Close the main switch to the position “0”.
- Close the disconnection device upstream of the Vertiv™ Liebert® AFC.

9.5 Restart Sequence

After a short stop	On the Vertiv™ Liebert® iCOM™ control panel set the switch to ON (see Start on page 62).
After a long stop	Complete the procedure as described in Power Up on page 61 , Unit Start-up on page 61 , and Start on page 62 .
Restart sequence in the event of a Power Failure (for units with refrigerant R513A).	<p>If the power failure is shorter than a certain time, the Vertiv™ Liebert® AFC restarts automatically. The time limits (to be managed by customer) are:</p> <ul style="list-style-type: none"> • Up to four hours without Fast Start Ramp Option • Up to one hour with Fast Start Ramp Option
Restart sequence for units with refrigerant R1234ze.	<p>If the power failure is less than five minutes, the Liebert® AFC restarts automatically.</p> <p>If the power failure is longer than five minutes, the Liebert® AFC needs a manual restart:</p> <ul style="list-style-type: none"> • On the Liebert® iCOM™, clear the alarm message due to the power fault. • Repeat the procedure of the previous point after a long stop.

9.6 Free Cooling

Direct free cooling is the process of rejecting heat using ambient air to pre-cool the process return fluid stream. The condenser fans on the chiller draw relatively cooler air through fluid-to-air heat exchangers (condenser coils) and extract heat from the return fluid stream. If the external (ambient) air temperature is lower than incoming return fluid, heat can be rejected from the process which can reduce the use of mechanical refrigeration. If the external temperature is low enough to dissipate the entire thermal load, mechanical refrigeration is no longer required, allowing the full heat rejection to be controlled and provided by modulating the condenser fans. If the temperature is too high, the compressors will run, requiring mechanical refrigeration to provide the heat rejection.

The conditions for which free cooling can be utilized are continuously monitored and managed by the on board chiller controls. The Vertiv™ Liebert® iCOM™ control system modulates a pair of electronically actuated control valves to direct the flow of water to provide the most efficient means for heat rejection based on ambient conditions.

10 Preventive Maintenance Checklist

The maintenance program below must be carried out by a qualified technician. Vertiv manufacturer trained technicians are certified to complete maintenance on the Vertiv™ Liebert® AFC product line. A minimum of two maintenance visits are recommended per year with four visits being optimal.

Fans

1. Check that the fan motor rotates freely and without abnormal noises. Make sure that the bearings do not heat up excessively.
2. Check and record current at 100% speed.
3. Confirm all electrical panels, doors and boxes are properly closed. Also confirm that all panel seals have been checked and the cable glands are tightened correctly to avoid altering the original IP protection rating of the same.

Condenser and Air Filters

1. Check the condition of the filters protecting the air exchangers. Clean them if necessary.
2. Check the condition of the electrical panel ventilation filters or electrical accessory compartments, if necessary replace them.
3. Check the condensing and free cooling coils (if applicable) and clean them if necessary (see coil cleaning procedures).

Control

1. Check that the control equipment, LEDs, and display are operating correctly.
2. Check and record the supply voltage.
3. Check the condition of the of the contactors (compressors, pumps, etc.).
4. Check the operation of the evaporator hydraulic circuit and fluid pressure drop.
5. Check the operation of the electrical panel fan and the heating elements (if present).
6. Ensure that all electrical connections are tight.
7. Check the correct calibration of the safety and control devices as well as their proper intervention.

Refrigeration Circuit

1. Check and record suction, discharge, and liquid pressures. Take and record sub-cooling of super heat. Record ambient temperature at time of check.
2. Check and record the compressor current, the supply temperature, and possible unusual noises.
3. Check the operation of the compressor's oil heaters.
4. Check the correct operation of the compressors' partialization solenoid valves, (if applicable).
5. Check the refrigerant charge by mean of the sight glass. Record any fluctuations of refrigerant in the site glass.
6. Check that the safety device operates correctly.
7. Check the correct operation of the EEV valve.
8. Check that the oil level indicated by the compressor sight glass is higher than the min value and record the oil level.

9. Check the sealing of the ON-OFF component (solenoid valves, shut-off valves, etc.).
10. Check and record compressor discharge temperature.
11. Take oil sample at product commissioning and annually on each compressor.

Water Circuit

1. Ensure that there are no water leaks.
2. Bleed any air out of the hydraulic circuit using the bleed valve.
3. Verify the correct water flow inlet.
4. Check and record the inlet and outlet water temperatures and pressures.
5. Check the correct operation of the two-way valves.
6. Check with the refractometer and record if the system is charged with the specified glycol percentage and that no ice has formed in the hydraulic circuit.
7. Check the evaporator cleanliness.
8. Check and record the electric pump current.
9. Check the noise of the electric pump.
10. Check the periodic lubrication of the electric pump.
11. Check the operation of the evaporator hydraulic circuit and fluid pressure drop. Record all pressure drops and pump speed.

Phase Correction Capacitors

1. Check once per year the Cr [μ F] is as indicated on component label (accepted $-5\%/+10\%$)
2. Check once per year the state of aluminum can and overpressure disconnecter.
3. For installations in hot climates or poor quality power supply, check and replace capacitors every two years according to working conditions.
4. For typical installations, check and replace capacitors every four years.

A2L Refrigerant Safety Sensor

1. Semiconductor gas sensor element: check calibration six months after commissioning and every 12 months thereafter.
2. Replace gas sensor element every two years.

Compressors Box Fans

1. Check fan functionality every 12 months.
2. Fan manufacturer specifies a life expectancy of 30-40k operating hours for bearing replacement and between 50 and 60k operating hours for motor winding.
3. Check for any leakage on joints, flange, connections, and sealings of refrigerant circuit. Necessary to have a leakage detector with sensitivity < 3 gr/year.

NOTE: The unit must never be left shut down with the liquid line valve closed, as liquid refrigerant can be trapped between this valve and the expansion device and lead to the risk of a pressure increase. This valve is situated on the liquid line before the filter drier box.



WARNING! RISK OF EXPLOSION: Never use air or a gas containing oxygen during leak tests to purge lines or to pressurize the unit. Pressurized air mixtures or gases containing oxygen can be the cause of an explosion.

Please consult leakage sensor control for respond time (normally less than 20 minutes), settings of lower and alarm threshold (150 – 500 ppm) taking care that full scale is at 1,000 ppm.

- The sensor should include internal self-checking diagnostics.
- The sensor should be set with lowest value from FCL (Flammable Concentration Limit) or 50% of PL (Practical Limit).
- For R1234ze(E), the different limits are defined as follows:
 - LFL - Lower Flammability Limit = 65,000 ppm
 - FCL - Flammable Concentration Limit equal 25% of the LFL = 16,000 ppm
- The ventilation system, refrigerant sensor, and alarm system should be routinely inspected as part of the maintenance program of the chiller.

During Commissioning:

- Check calibration.
- Check LEDs for proper operation.
- Check for proper buzzer and relay operation.
- Check signal transmission to the controller if connected.



WARNING! Semiconductor sensitive elements should be checked after exposure to significant concentrations of gas, which can shorten the sensor lifetime and/or reduce its sensitivity.

This page intentionally left blank

11 Maintenance

NOTICE

Check the unit regularly and solve problems as they occur. Lack of maintenance could reduce performance or damage the unit.



WARNING! Only authorized personnel are allowed to do maintenance operations. All work on pipes or components of the refrigerating circuit under pressure must be exclusively made by qualified staff competent in such work. The authorized personnel must be properly trained and qualified, wear appropriate personal protective equipment and use adequate tools.



WARNING! Unit contains potentially lethal voltage in some circuits. Risk of arc flash and electric shock. Can cause injury or death.

Open all local and remote unit electric power disconnect switches, verify with a voltmeter that power is OFF and wear protective equipment per local standard before working within the electric control enclosure.

It is forbidden to operate on the electrical components without using insulating platforms, or in the presence of water and humidity.



WARNING! The electric connection enclosures and some components can retain a stored high-voltage electrical charge for up to 10 minutes. Risk of electric shock. Can cause serious injury or death.

Before working within the unit electric connection enclosures proceed as follows:

Open all local and remote unit electric power disconnect switches.

Wait 10 minutes.

Verify with a voltmeter that power is OFF.

Only properly trained and qualified personnel may perform repair, maintenance, and cleaning.



WARNING! Before any intervention on the electrical system or accessing the inner components:

Lock the disconnection devices by a padlock or similar tool.

Apply on the general knife switch a suitable warning plate for no operation.



CAUTION: The front part of the compressor and the delivery pipe and the condenser are very hot.

Be careful when operating nearby.

Always wear temperature resistant gloves when operating on the unit.



CAUTION: After the maintenance interventions, always close the unit by refitting the relevant panels, if present, fastened by the fixing screws.



CAUTION: Sharp edges, splinters, and exposed fasteners. Wear protective gloves before operating on the unit.

11.1 Cleaning the Condenser and Free Cooling Coils

The operating environment of the units can have a certain impact on the life of the microchannel coils.

Any obstructions due to dust, pollution, etc. may accumulate between the fins and can typically be cleaned utilizing pressurized water. This should be done periodically.

Do not use chemicals to wash the microchannel condenser coils.

Before cleaning:

1. Disconnect the unit from the power supply.
2. Wait for the fans to stop completely.
3. Make sure that the fan blades cannot move for any reason (for example, wind). Lock them mechanically to avoid accidental contact with the rotating blades.
4. If present, remove the air filters and the "V" shaped panels.
5. Remove the narrow and long panel between the microchannel battery and free cooling.

Figure 11.1 Removing the Panel

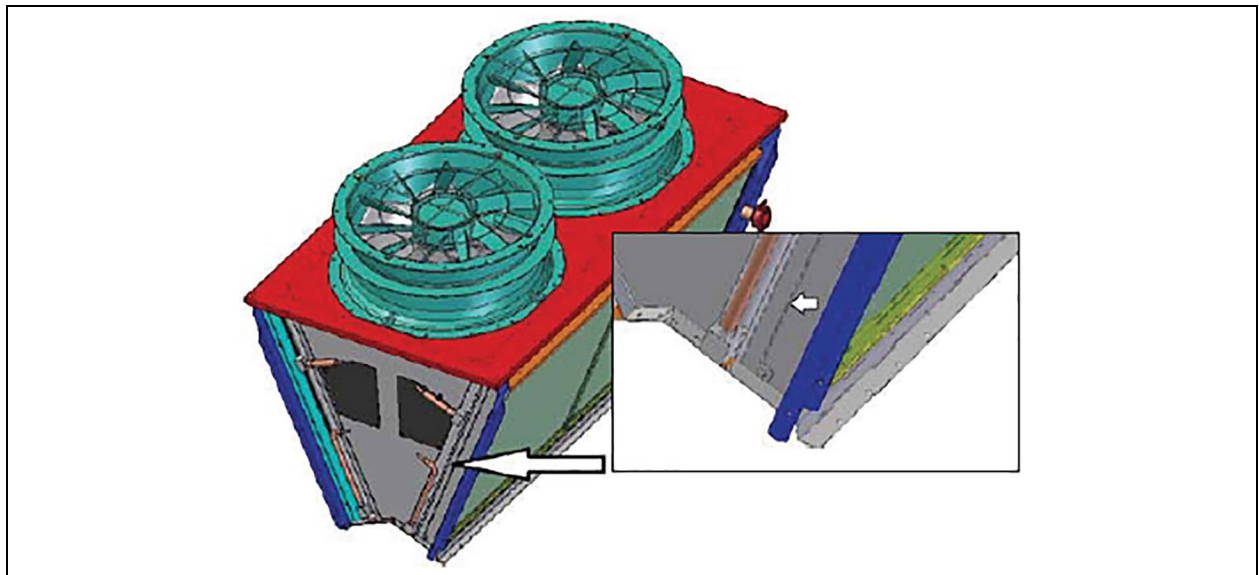

6. Insert the bulkhead between the microchannel and the free cooling coil so that the lower channel is facing the free cooling coil.

Figure 11.2 Inserting the Bulkhead

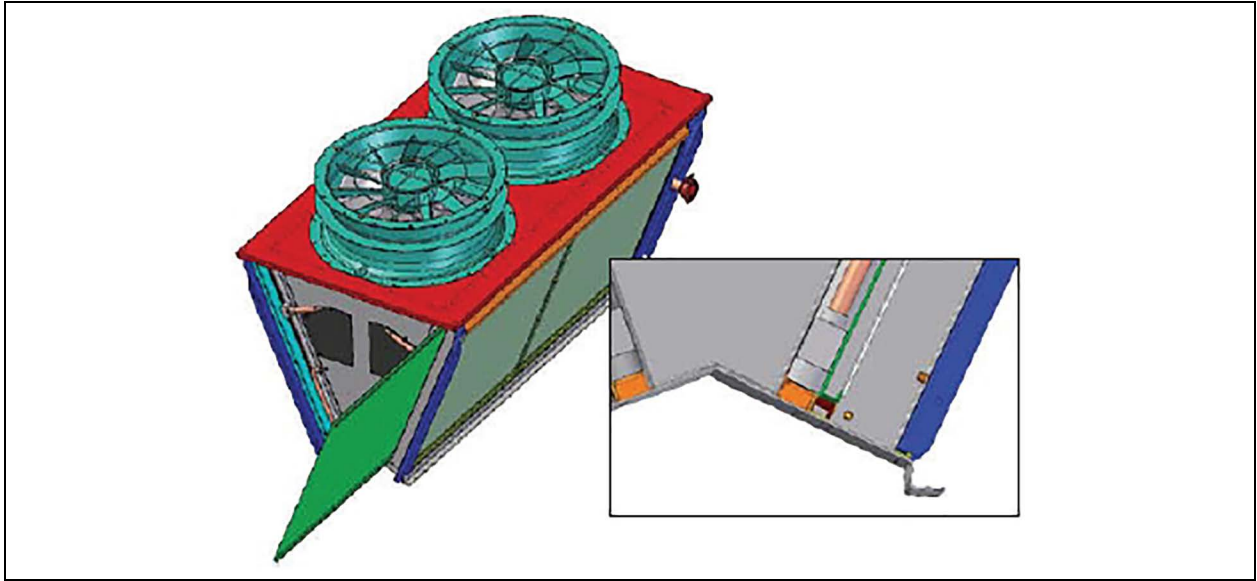

7. Wash the free cooling coils with water at a distance of about 8 inches (20 cm) from the coil surface.



CAUTION: Higher pressures and/or the use of pressurized water with a distance of less than 8 inches (20 cm) from the coil surface could damage the fins.

8. Remove and rotate the bulkhead in such a way that the lower channel is facing the microchannel condenser coil.

Figure 11.3 Remove and Rotate the Bulkhead

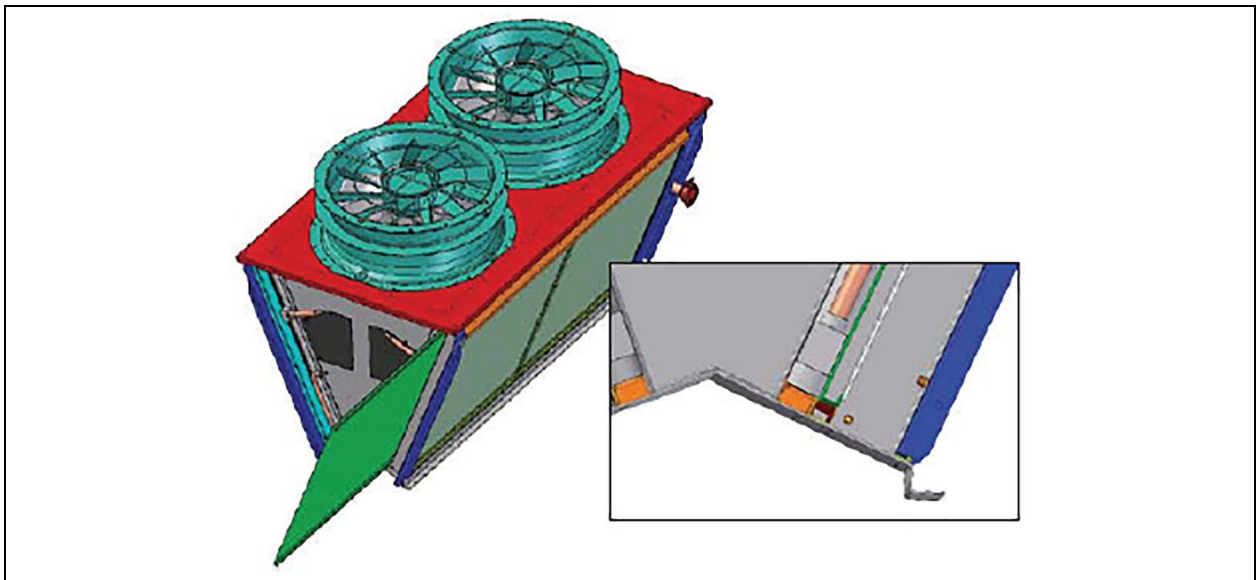

9. In order to use the windows on the "V" shaped partition, it is necessary to have a nozzle with right angle flow. If you do not have this type of nozzle, you must remove the fans and introduce the nozzle into the internal space of the unit.

10. Wash the microchannel coil with water at a distance of about 8 inches (20 cm.).



CAUTION: Higher pressures and/or the use of pressurized water with a distance of less than 2 inches (5 cm) from the coil surface could damage the fins.

11.2 Lubrication of Pumps

The bearings of motors with power up to 11 kW are greased for life and therefore do not require lubrication.

The bearings of motors with power equal to or greater than 11 kW must be lubricated in accordance with the indications on the motor nameplate, in particular observing the required intervals.

11.3 Refrigeration System

11.3.1 Refrigerant Charge

Before shipment each unit is charged with the proper amount of refrigerant and oil.

If the refrigerant circuit is intervened at site, the circuit might lose a small portion of refrigerant and a refrigerant charge may be needed.

NOTICE

It is important to carry out charging correctly. An excess of refrigerant causes an increase in sub-cooling and consequent operating difficulties in the hot season. A shortage of charge generates an increase in superheating and possible compressor stoppages.

NOTICE

In case of extraordinary maintenance on inverter units, to vacuum the refrigerant circuit without applying main voltage, it is first necessary to activate "Evacuation mode" of the CSV to keep the compressor internal valves open. Then, before re-charging the system it is important to power-up the frequency inverter and deactivate the "Evacuation mode" so that the valves close.

11.3.2 Oil Charge

Before shipment each unit is charged with the proper amount of refrigerant and oil. If there has been any loss of oil, then this must be replaced.

NOTICE

Pay attention on the type of synthetic polyester oil as indicated on stickers attached on compressor's frame; on R1234ze units there are two different type of oil between each circuit (BSE170 for fixed screw, BSE170 L on inverter screw).

NOTICE

Contact Vertiv Technical Support for the oil specifications to be used for topping up.

Refilling up to 20-30% of the total amount of oil contained in the compressor crankcase are permitted; for larger percentages contact the technical support department.

11.3.3 Compressor Maintenance Schedule - Checks and Tests

Compressor Reverse Direction	To protect against reverse rotation when stopped, a check valve is included under the compressor's delivery valve. If the compressor runs in reverse direction for more than five seconds after switch-off, the valve may be damaged and should be replaced.
Periodic Check	Check the correct functioning every 5,000 compressor working hours.
Bearings	<p>Screw compressors are equipped with fatigue resistant bearings, therefore replacement is not necessary provided that the refrigerant circuits are operated under standard conditions within the operating limits and respecting the indicated maintenance schedule.</p> <p>Bearing wear detection is to be carried out by sound analysis.</p> <p>The recommended inspection interval is every 10,000 compressor working hours.</p> <p>Please contact our Service department for replacing bearings if necessary; . Only authorized service centers are authorized to open the screw compressor.</p>
Motor	It is important to check the motor wear by measuring the resistance of the insulation of its windings. The recommended inspection interval is every 10,000 compressor working hours.

11.3.4 Filter Drier

Replace the Cartridges

Vertiv™ Liebert® AFC is equipped with a shut-off valve on the liquid line upstream of the refrigerant filter.

1. Close the shut-off valve.
2. Replace the cartridges.
3. Open the shut-off valve.

NOTICE

The used cartridges are hazardous waste and must be disposed according with the local regulations.

11.4 Decommissioning and Winterizing the Water System

11.4.1 Glycol

In winter, if the system is stopped, the water inside the exchangers can freeze damaging the system irreparably.

See [Freeze Protection](#) on page 55.

NOTICE

Always charge the hydraulic circuit with the required glycol percentage necessary for the minimum ambient temperature of the installation site. Failing to comply with this instruction shall invalidate the unit warranty.

11.4.2 Draining

Drain the system completely, using the shut-off valves arranged in the exchangers and in the circuit, and purge any remaining water by blowing dehydrated nitrogen in the lines.

For units that include a water glycol mixture please refer to local regulatory standards for handling and disposal.

12 Troubleshooting

Symptom	Possible Cause	Check or Remedy
The unit does not start.	No power supply to the unit.	Check voltage at input terminal block.
	The circuit breaker or fuse for low-voltage transformer in unit is tripped.	Locate the problem in unit electrical panel and repair.
Low evaporating pressure	Low refrigerant charge	Check refrigerant charge.
	EEV problem	Check EEV configuration.
	High pressure drop on the liquid line	Check shut-off valve, filter drier.
High condensing pressure	High refrigerant charge	Check refrigerant charge.
	Problem with condensing control fans	Check condensing control fans.
The compressor does not run or does not run properly.	Flow switch not responding.	Check the flow switch.
	The connection is loose or disconnected.	Check the connection to verify that is connected securely.
	The compressor doesn't modulate capacity properly.	Check the solenoid valves.
	The high pressure switch has shut off the unit.	Check the high pressure switch.
High vibration on the unit	The compressor is not properly fixed.	Check the compressor dampers.
	The discharge and suction piping are not properly fixed.	Check the piping.
	The unit damper (if installed) is not properly fixed.	Check the unit damper.
	The unit is not properly connected to the hydraulic circuit.	Check the joint connection.

This page intentionally left blank

Appendices

Appendix A: Technical Support and Contacts

A.1 Technical Support/Service in the United States

Vertiv Group Corporation

24x7 dispatch of technicians for all products.

1-800-543-2378

Liebert® Thermal Management Products

1-800-543-2378

Liebert® Channel Products

1-800-222-5877

Liebert® AC and DC Power Products

1-800-543-2378

A.2 Locations

United States

Vertiv Headquarters

505 N. Cleveland Ave.

Westerville, OH 43082, USA

Europe

Via Leonardo Da Vinci 16/18 Zona Industriale Tognana

35028 Piove Di Sacco (PD) Italy

Asia

7/F, Dah Sing Financial Centre

3108 Gloucester Road

Wanchai, Hong Kong

This page intentionally left blank

Appendix B: Submittal Drawings

Table B.1 Submittal Drawings Contents

Document Number	Title
Foot Print, Clearances, and Cabinet Dimensions	
20000109	Cabinet - Chiller, Direct and Indirect Freecooling (C,F,N - 12-20 Fans)
Electrical Field Connections	
DPN005148	Electrical Field Connections
Lifting Instructions	
DPN005265	Lifting Instructions with 8 Brackets (14-16-18-20 Fans Unit)
Refrigerant Circuit	
DPN005267	Refrigerant Circuit Diagram
Piping Schematic	
DPN005268	Piping Schematic Hydraulic - Chiller (12-20 Fans)
DPN005269	Piping Schematic Hydraulic - Direct Free Cooling (12-20 Fans)

This page intentionally left blank

LIEBERT® AFC CHILLER

OVERALL DIMENSIONS AND CLEARANCES FH3 / CH3 SERIES

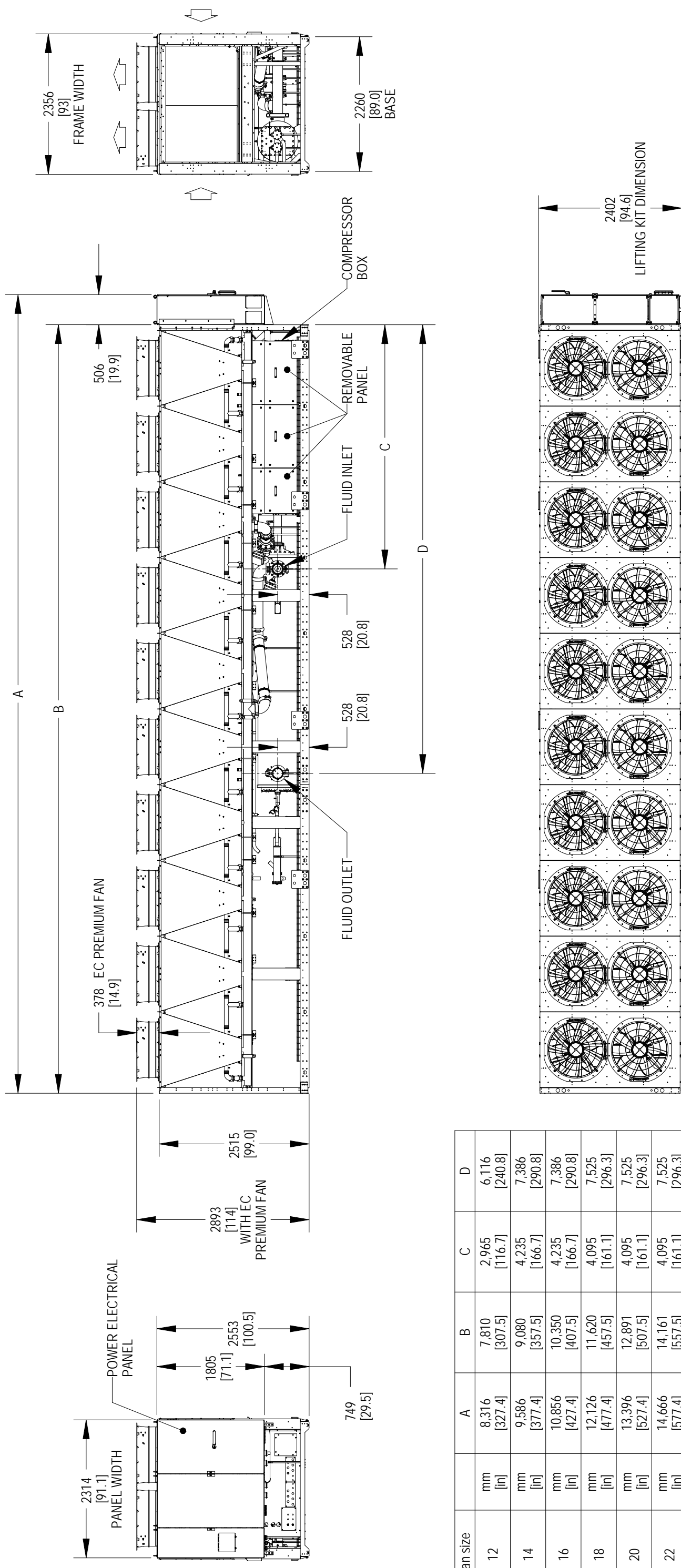

NOTES	
	AIR FLOW
CONNECTIONS	
INLET	OUTLET
GROOVED 6" OPTION: FLANGED	GROOVED 6" OPTION: FLANGED

LIEBERT® AFC CHILLER

OVERALL DIMENSIONS AND CLEARANCES FH3 / CH3 SERIES

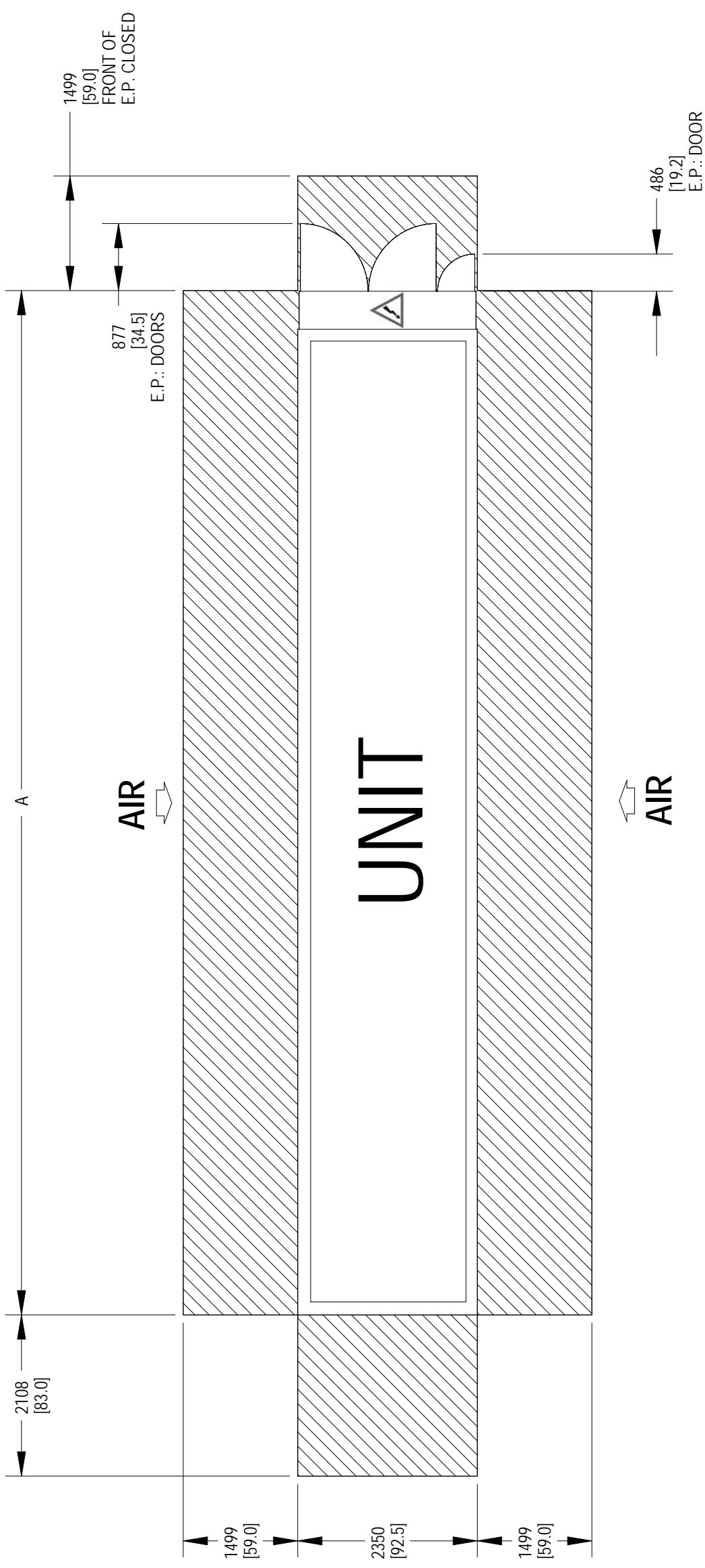

THE FLOOR LEVEL IN THE MAINTENANCE AREA ON THE ELECTRICAL PANEL SIDE MUST BE ALIGNED WITH THE SURFACE WHERE THE UNIT IS PLACED, ENSURING EASY AND SAFE ACCESS TO THE ELECTRICAL PANEL, COMPLYING WITH APPLICABLE SAFETY REGULATIONS.

NOTE: REFER TO PAGE 1 FOR "A" DIMENSIONS.



LIEBERT® AFC CHILLER

ELECTRICAL FIELD CONNECTIONS

STANDARD ELECTRICAL CONNECTIONS

- 1) **High Voltage Entrance** - Located on bottom right of Electric Box, removable sealed plate. Enclosure is provided with provisions for a field installed power entry kit to be completed by installer in the field. Power entry kits are not provided with holes or knockouts, which must be done by the installer in the field. The fittings used must have the proper environmental rating per code.
- 2) **Low Voltage Entrance** - Located on bottom left of Electric Box, recommended location. Enclosure is not provided with holes or knockouts, which must be done by the installer in the field. The fittings used must have the proper environmental rating per code.
- 3) **3-Phase Electrical Service** - Terminals are on bottom of disconnect switch. See serial tag for electrical values. 3-Phase service not provided by Vertiv.
- 4) **1-Phase Electrical Service** - Terminals for GFCI (standard) and Low Ambient Heat Tracing (optional) are behind deadfront. See circuit breaker for max amperage, 120VAC. 1-Phase service not provided by Vertiv.
- 5) **Earth ground** - Terminal for field supplied earth grounding wire. Earth grounding required for Vertiv units.
- 6) **Unit Factory Installed Disconnect Switch and Main Fuses** - Access to the high voltage electrical box door can be obtained only with the switch in the "off" position. A fused disconnect is provided with a defeater button that allows access to the electrical box when power is on.

STANDARD 24V AND 120V CONNECTIONS

- 7) **Customer Connection Terminals** - Use field supplied Class 1 wiring.
- 8) **Remote Shutdown Device** - Terminals for field supplied, 24VAC signal, minimum 100mA, between terminals 37 & 38.
- 9) **Common Alarm** - On any alarm, normally open dry contact is closed across terminals 75 & 76 for remote indication. 1 AMP, 24VAC max load.
- 10) **General Alarm** - On alarm, normally open to common, across terminals 52 & 53, and 94 & 95 and normally closed to common dry contact across terminals 53 & 54, and 95 & 96, 1 AMP, 24VAC max load.
- 11) **User Input** - Terminals for field supplied, 24VAC signal, minimum 100mA, between terminals 50 & 51.
- 12) **Programmable Events** - On programmed alarm, normally open dry contact is closed across terminals 55 & 56 for remote indication. 1 AMP, 24VAC max load.
- 13) **Dedicated 120VAC Circuit for Service Outlet** - In 120VAC section.
- 14) **Dedicated 120VAC Circuit for Low Ambient Heat Tracing (Optional)** - In 120VAC section.

OPTIONAL COMMUNICATION CONNECTIONS

- 15) **Unit-To-Unit Communication** - On network switch, Port 5 is reserved for U2U connections. Use an eight pin RJ45 for cat 5 cable.
- 16) **Site and BMS Communication** - On the controller, BMS single port is reserved for Site and BMS connections. Use an eight pin RJ45 cable.



LIEBERT® AFC CHILLER

ELECTRICAL FIELD CONNECTIONS

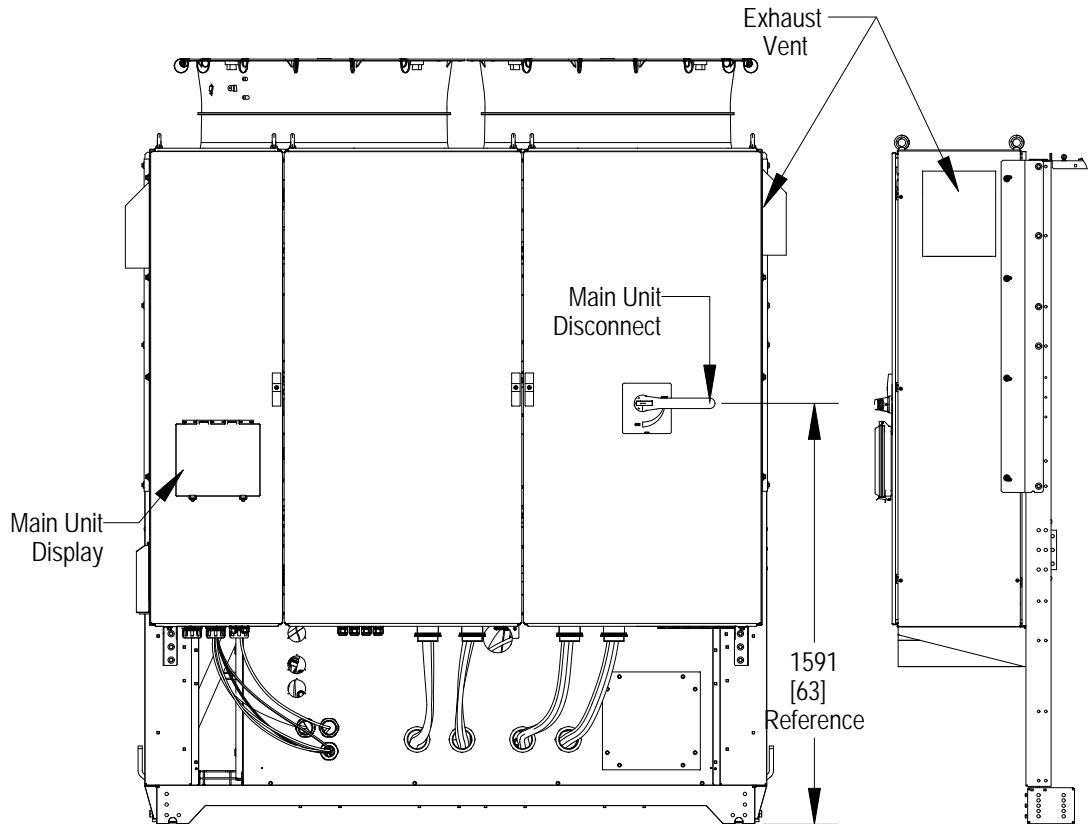

FRONT OF ELECTRICAL BOX
(DOORS CLOSED)

Notes:

- 1.Primary Unit of Measure mm
- 2.Secondary Unit of Measure inch



LIEBERT® AFC CHILLER

ELECTRICAL FIELD CONNECTIONS

FRONT OF ELECTRICAL BOX
(DOORS REMOVED FOR CLARITY)

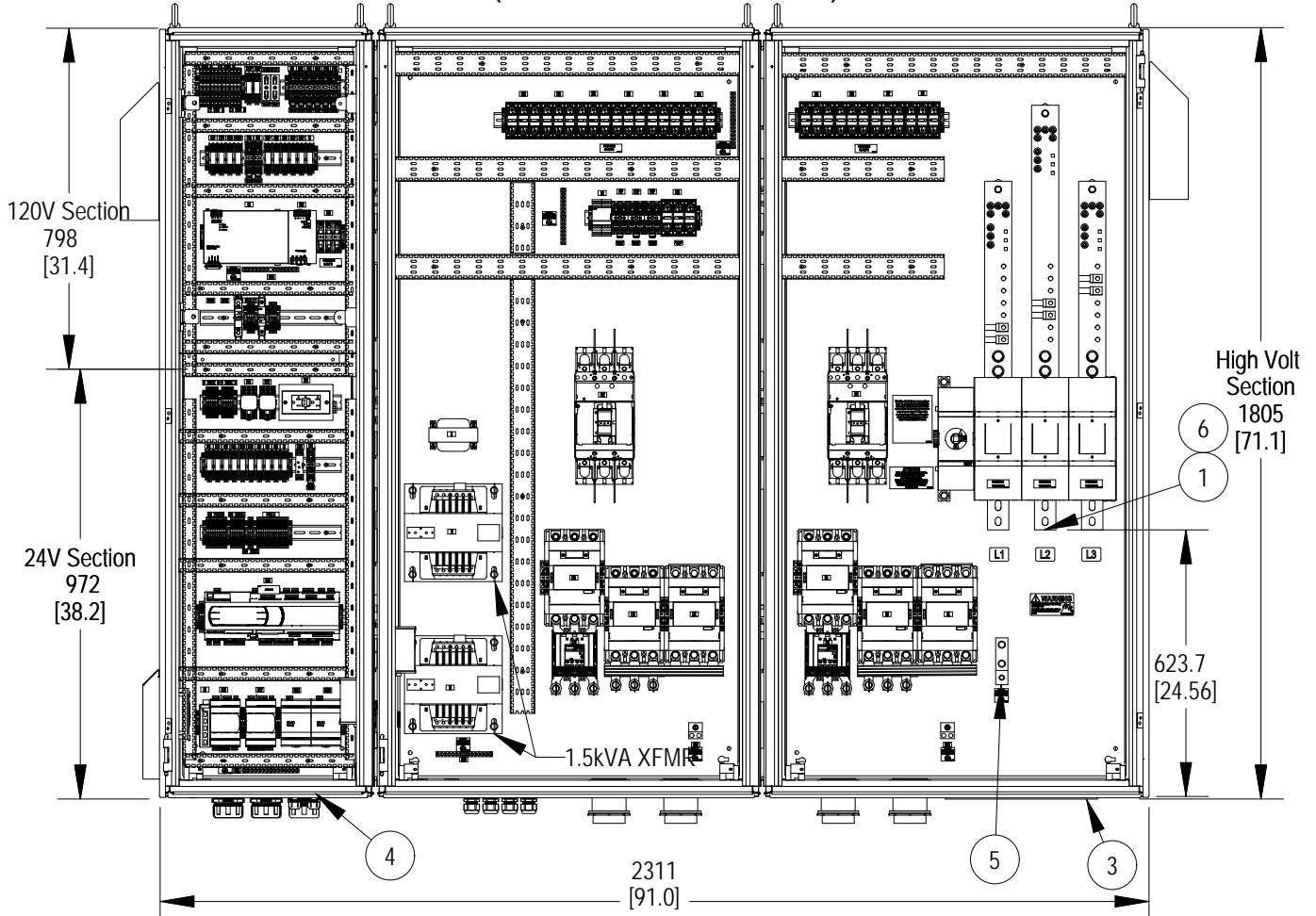

BOTTOM VIEW OF ELECTRICAL BOX FRONT OF ELECTRIC BOX

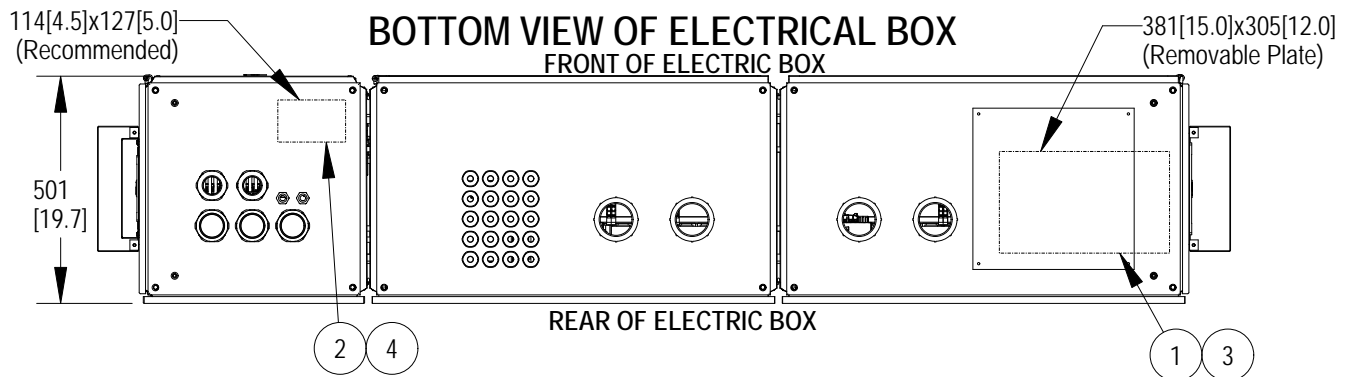

STANDARD ELECTRICAL CONNECTIONS (from Page 1)

- 1) High Voltage entrance - Recommended location
- 2) Low Voltage entrance - Recommended location
- 3) 3-Phase Electrical Service
- 4) 1-Phase Electrical Service
- 5) Earth Ground - Connection for 3-Phase electrical service
- 6) Unit Factory Installed Disconnect Switch and Main Fuses

Notes:

1. Primary Unit of Measure mm
2. Secondary Unit of Measure inch
3. Deadfront and latch hidden for clarity
4. Customer to provide connection lugs to the Disconnect where the #1 and #6 balloons are.
5. HV section is a reference of Fixed Compressor layout



LIEBERT® AFC CHILLER

ELECTRICAL FIELD CONNECTIONS

24V SECTION: CUSTOMER CONNECTIONS

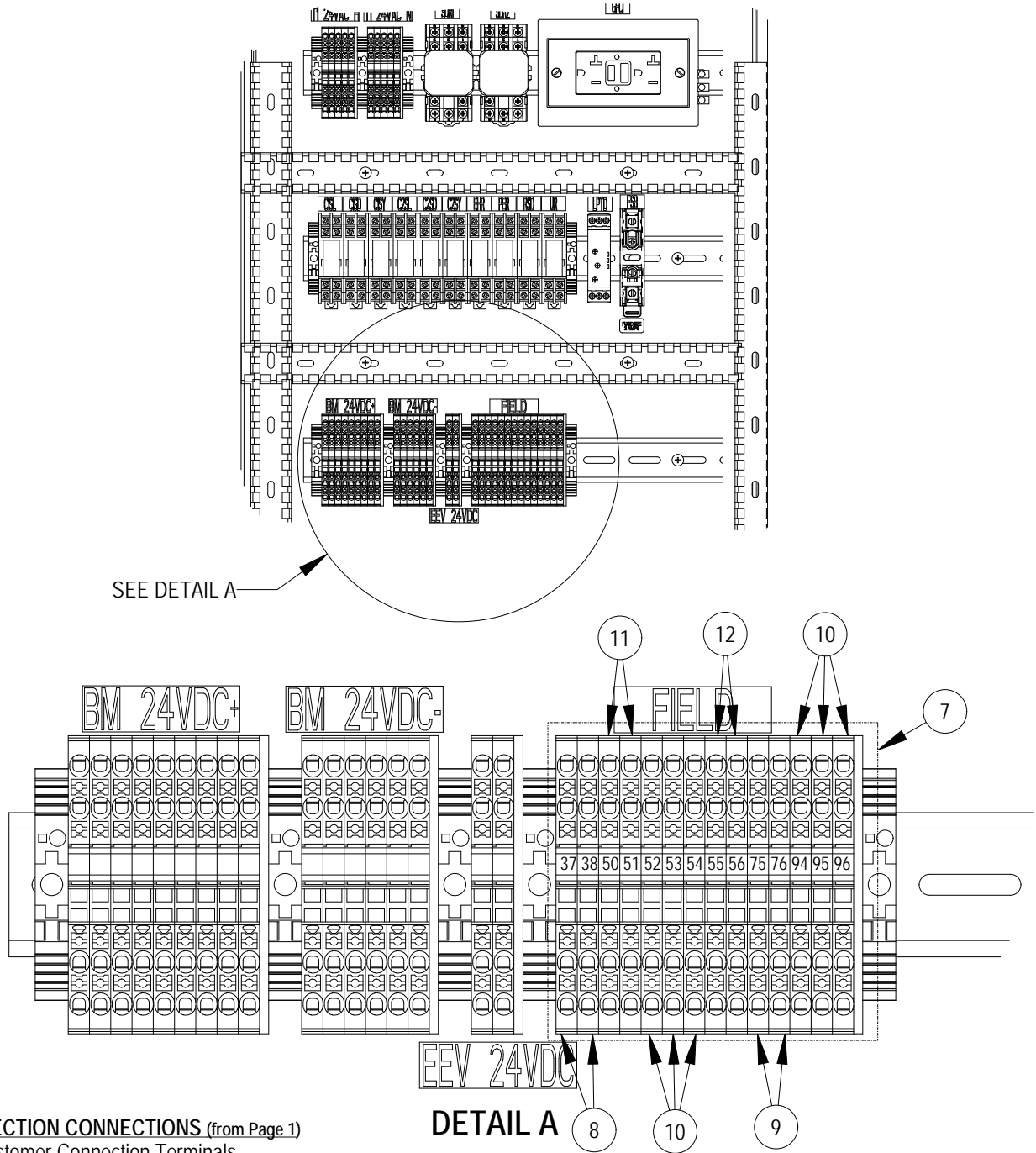

24V SECTION CONNECTIONS (from Page 1)

- 7) Customer Connection Terminals
- 8) Remote Shutdown Device
- 9) Common Alarm
- 10) General Alarm
- 11) User Input
- 12) Programmable Events



LIEBERT® AFC CHILLER

RIGGING INSTRUCTIONS CHILLER, DIRECT AND INDIRECT FREECOLING (C,F,N 14-20)

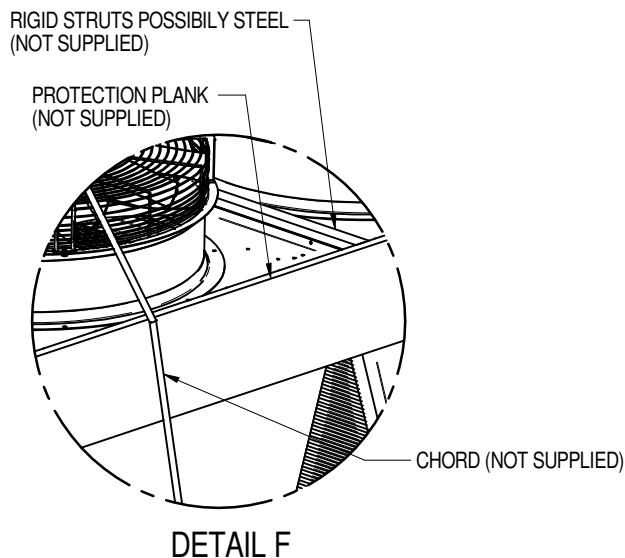
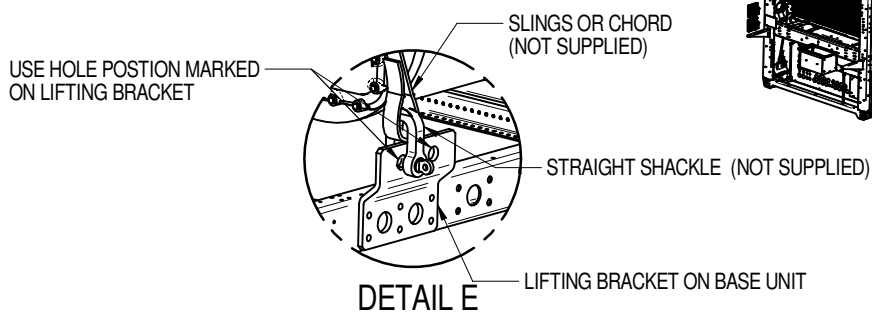
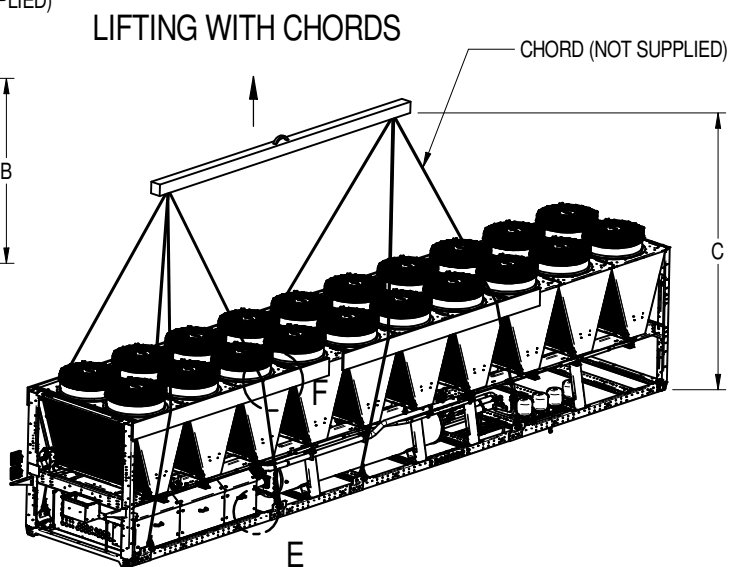
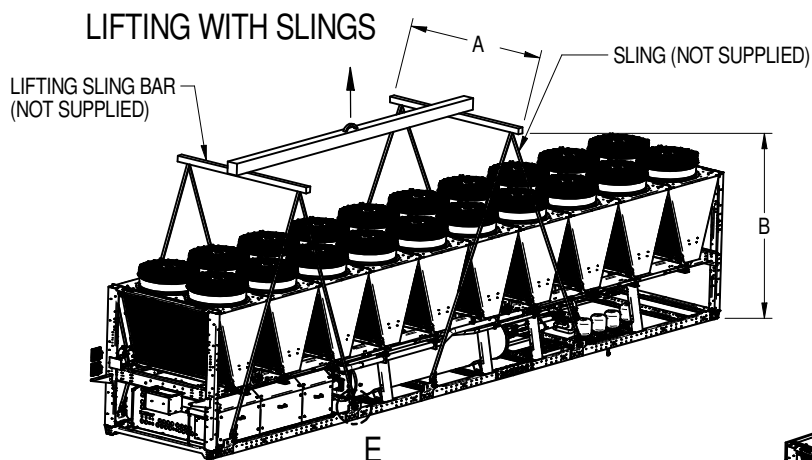

Models (* = R-513A/R-134A)	Fans n.	A (mm)	B (mm)	C (mm)
FH*/NH*/CH* 145-160	18	~2800	~5000	~10000
FF*/NF*/CF* 175	20	~2800	~5000	~10000
FH*/NH*/CH* 175				

Notes:

1. The capacity of the lifting gear must be adequate to lift the load in question.
2. Check the weight of the units, the capacity of the lifting gear and ropes and the condition and suitability of the aforementioned equipment.
3. Lift the unit with a speed suitable for the load to be moved, so as not to damage the structure unit.
4. After lifting and positioning the unit, remove lifting accessories (ropes, slings, chains, hooks, brackets).
5. Lifting tools as hooks, lifting gear, ropes, chords, slings, rigid struts, protection plank are not provided with the unit.



LIEBERT® AFC CHILLER

RIGGING INSTRUCTIONS CHILLER, DIRECT AND INDIRECT FREECOLING (C,F,N 14-20)

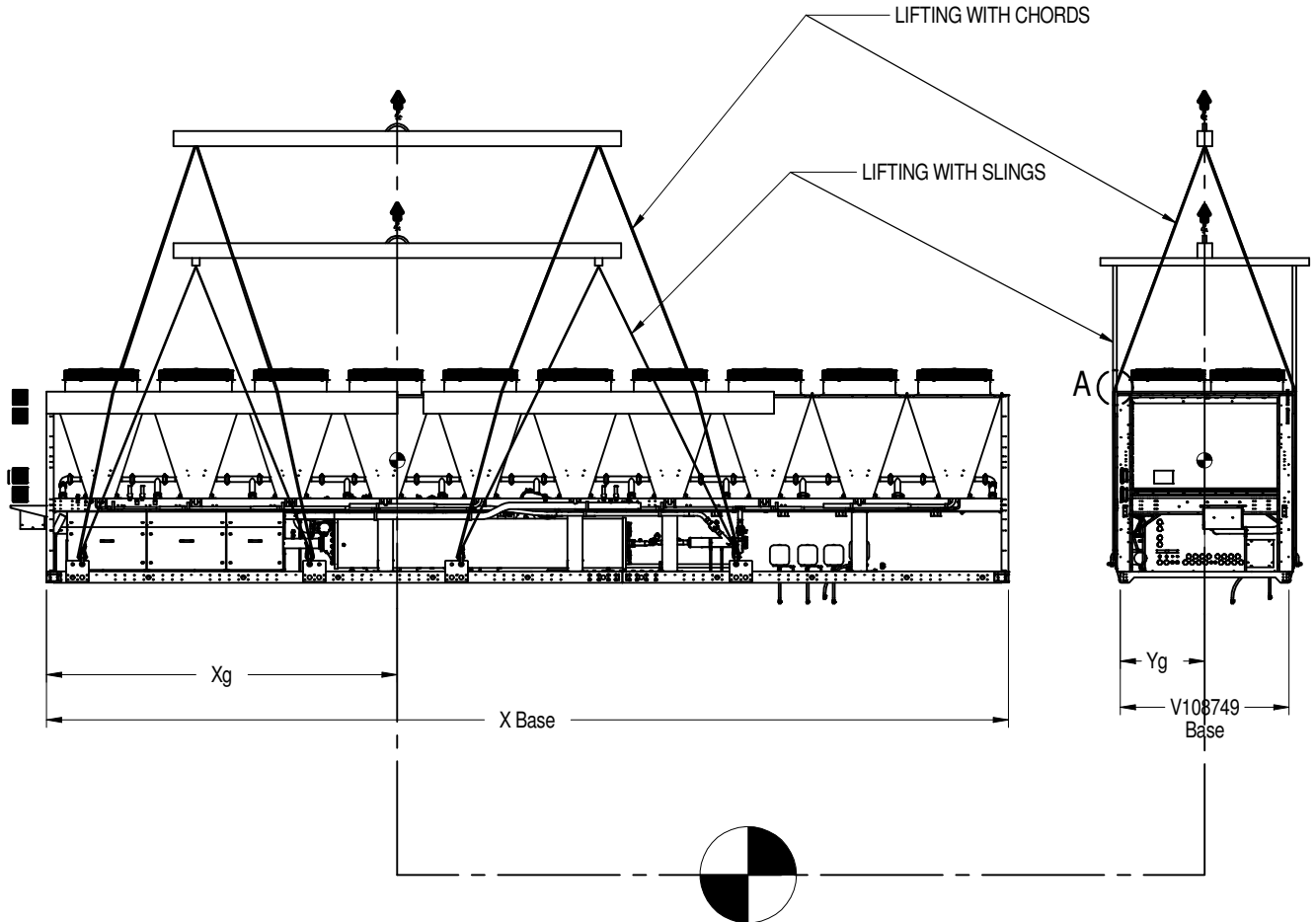

N.B.: The lifting point has to be on the vertical baricentric axis, which is individualized by symbols indicated on the base.

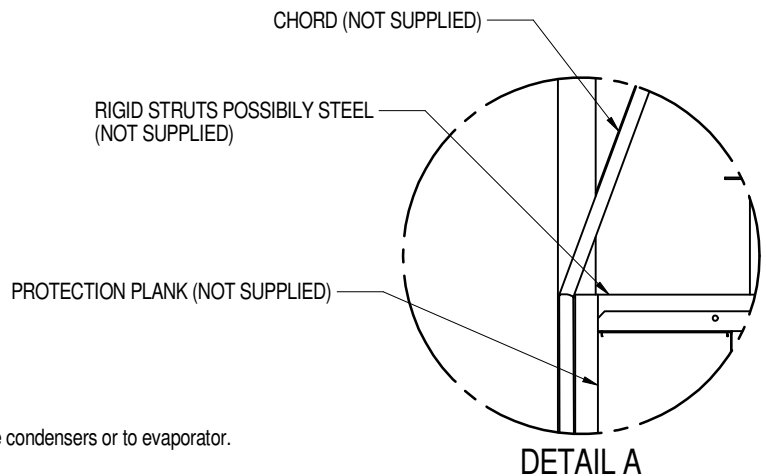

Notes:

1. Do not tilt the unit more than 15°.
2. No force must be applied to pressurized parts, especially pipes connected to the condensers or to evaporator.



LIEBERT® AFC CHILLER

RIGGING INSTRUCTIONS CHILLER, DIRECT AND INDIRECT FREECOLING (C,F,N 14-20)

Unit without pumps (* = R-513A/R-134A)					
Models	Fans	X Base (mm)	Unit without pumps		
			Xg (mm)	Yg (mm)	Weight (kg)
FH*/NH*/CH* 145-160	18	9080	4306	1139	13280
FF*/NF*/CF* 175	20	12890	4750	1267	13993
FH*/NH*/CH* 175		12890	4750	1172	14247

Unit without pumps (* = R-513A/R-134A)						
Models	Fans	Height (mm)	Width (mm)	Lenght (mm)	Static Weight (kg)	Operating Weight (kg)
FH*/NH*/CH* 145-160	18	9080	4306	1139	13280	15171
FF*/NF*/CF* 175	20	12890	4750	1267	13993	16112
FH*/NH*/CH* 175		12890	4750	1172	14247	16191



LIEBERT® AFC CHILLER

REFRIGERANT CIRCUIT PIPING SCHEMATIC AFC DOUBLE FIXED SPEED SCREW COMPRESSOR

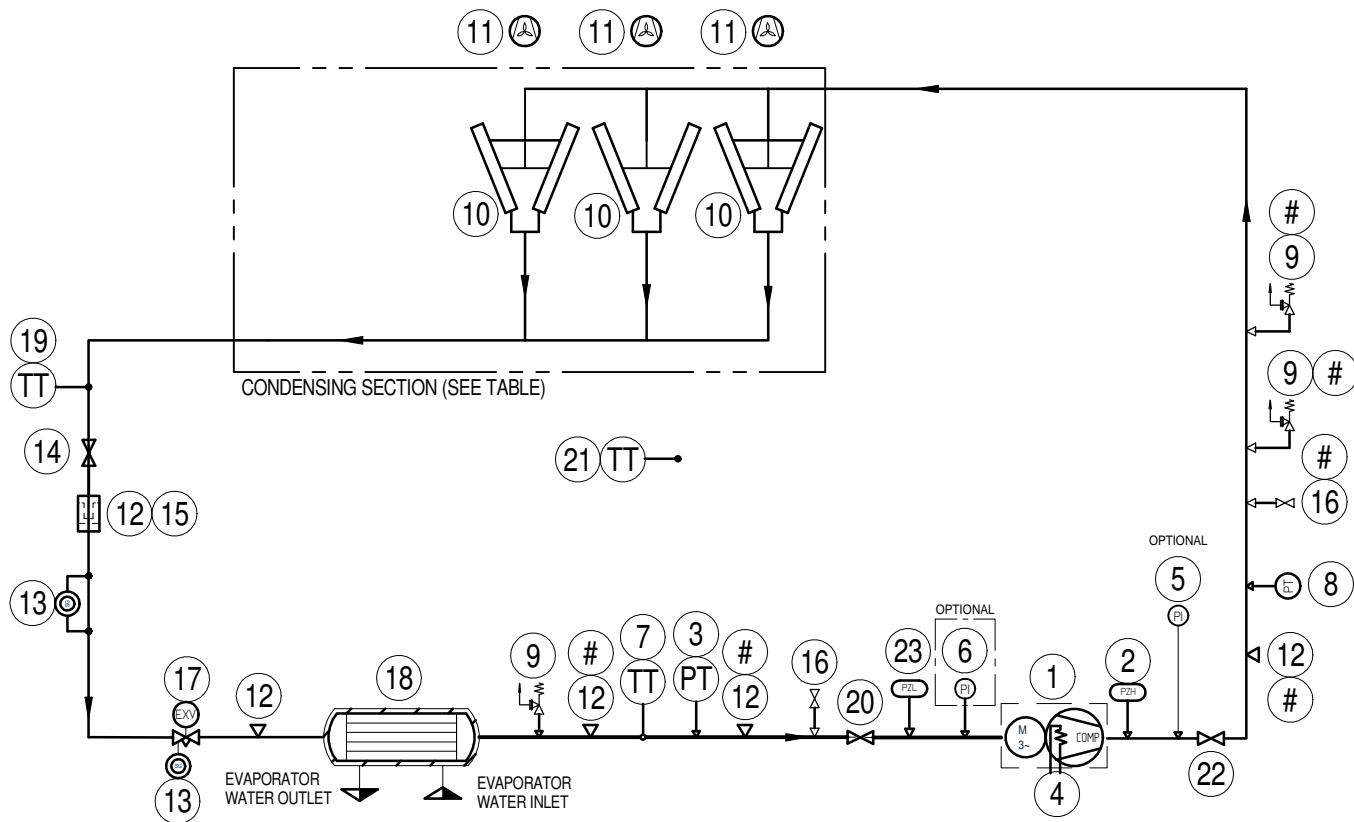

STANDARD DEVICES	
1 COMPRESSOR	13 SIGHT GLASS
2 HIGH PRESSURE SWITCH	14 SHUT-OFF VALVE
3 LOW PRESSURE TRANSDUCER	15 FILTER DRYER
4 CRANKCASE HEATER	16 CHARGE/PURGE VALVE
5 HIGH PRESSURE MANOMETER	17 ELECTRONIC EXPANSION VALVE
6 LOW PRESSURE MANOMETER	18 EVAPORATOR
7 SUCTION TEMPERATURE SENSOR	19 LIQUID TEMPERATURE SENSOR
8 HIGH PRESSURE TRANSDUCER	20 COMPRESSOR SUCTION VALVE
9 SAFETY VALVE	21 EXTERNAL AIR TEMPERATURE SENSOR
10 CONDENSER	22 COMPRESSOR DISCHARGE VALVE
11 CONDENSER FANS	23 LOW PRESSURE SWITCH
12 SERVICE CONNECTION	

— INSULATED PIPE

— NOT INSULATED PIPE

THE POSITION IS INDICATIVE AND CAN CHANGE ON DISCHARGE / LIQUID MANIFOLD OR SUCTION PIPE

OPTIONAL SAFETY VALVES

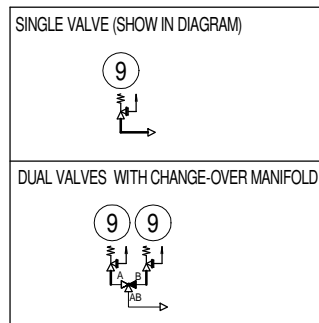

UNIT MODEL	FAN QUANTITY	NUMBER OF CIRCUITS	CIRCUIT 1 CONDENSERS QTY	CIRCUIT 2 CONDENSERS QTY
CH3/FH3/NH3 090	12	2	6	6
CH3/FH3/NH3 105	14	2	7	7
CH3/FH3/NH3 120	16	2	8	8
CH3/FH3/NH3 130	16	2	8	8
CH3/FH3/NH3 145	18	2	9	9
CH3/FH3/NH3 160	18	2	9	9
CH3/FH3/NH3 175	20	2	10	10

Notes:

- Two refrigeration circuits provided. Single refrigeration circuit shown for clarity.
- Evaporator has (2) independent refrigeration circuits with shared evaporator water side circuit.
- Schematic representation shown. Do not use for specific connection locations.



LIEBERT® AFC CHILLER

HYDRAULIC PIPING SCHEMATIC CHILLER (12-20 FANS)

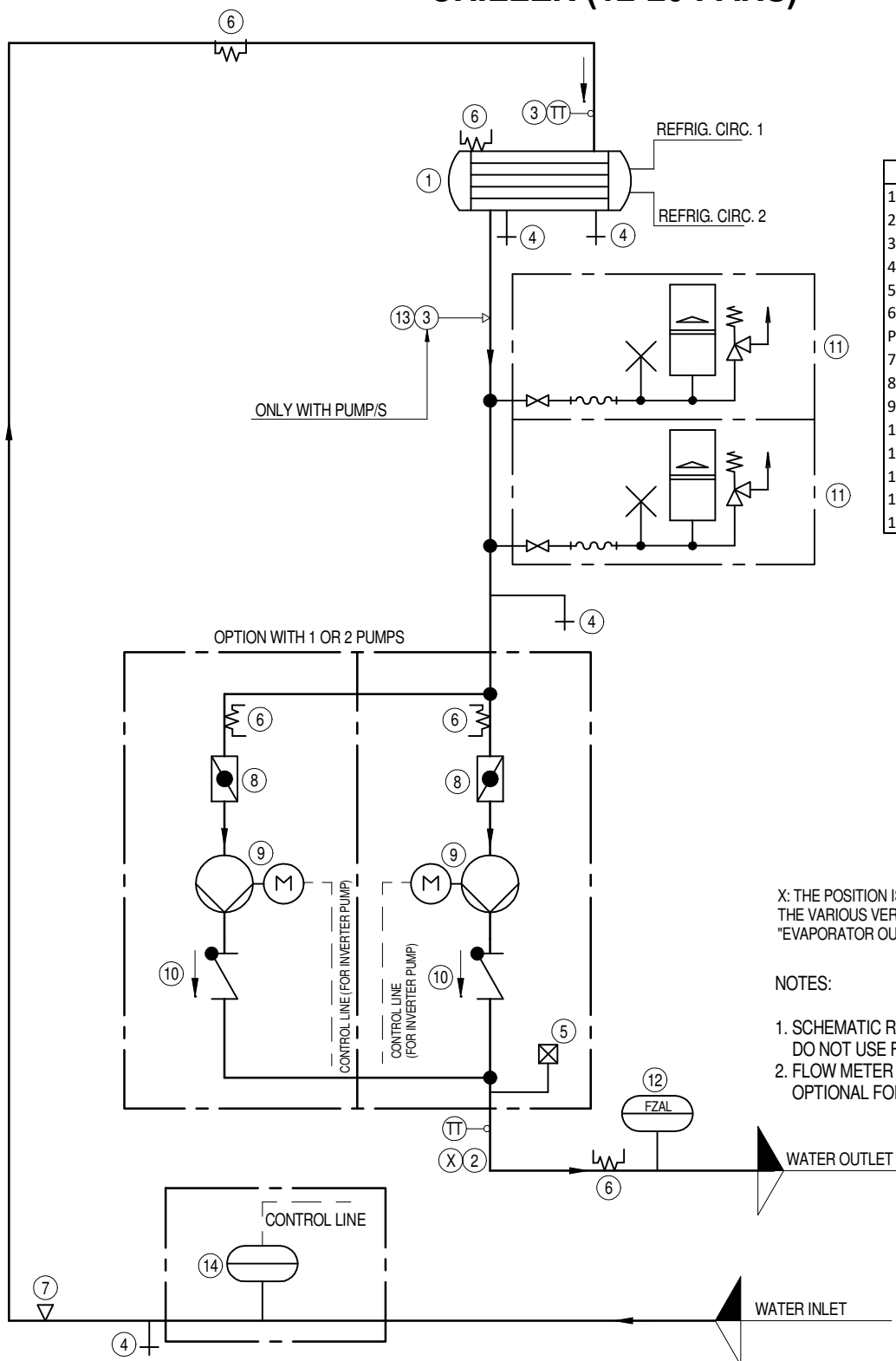

STANDARD DEVICES	
1	EVAPORATOR
2	EVAPORATOR WATER OUTLET SENSOR
3	EVAPORATOR WATER INLET SENSOR
4	DRAIN VALVE
5	AIR VENT VALVE
6	ELECTRICAL HEATERS FOR EXCHANGER / PIPE (OPTIONAL)
7	SERVICE CONNECTION
8	BUTTERFLY VALVE
9	PUMP
10	CHECK VALVE
11	VARIABLE FLOW HYDRAULIC KIT
12	FLOW SWITCH
13	PRESSURE TRASDUCER
14	FLOW METER

X: THE POSITION IS INDICATIVE AND CAN CHANGE IN THE VARIOUS VERSIONS ALONG THE LINE "EVAPORATOR OUTPUT-CUSTOMER UNIT CONNECTION"

NOTES:

1. SCHEMATIC REPRESENTATION SHOWN. DO NOT USE FOR SPECIFIC CONNECTION LOCATIONS.
2. FLOW METER IS STANDARD WITH ELECTRONICS PUMP/S, OPTIONAL FOR OTHERS.



LIEBERT® AFC CHILLER

HYDRAULIC PIPING SCHEMATIC DIRECT FREE COOLING (12-20 FANS)

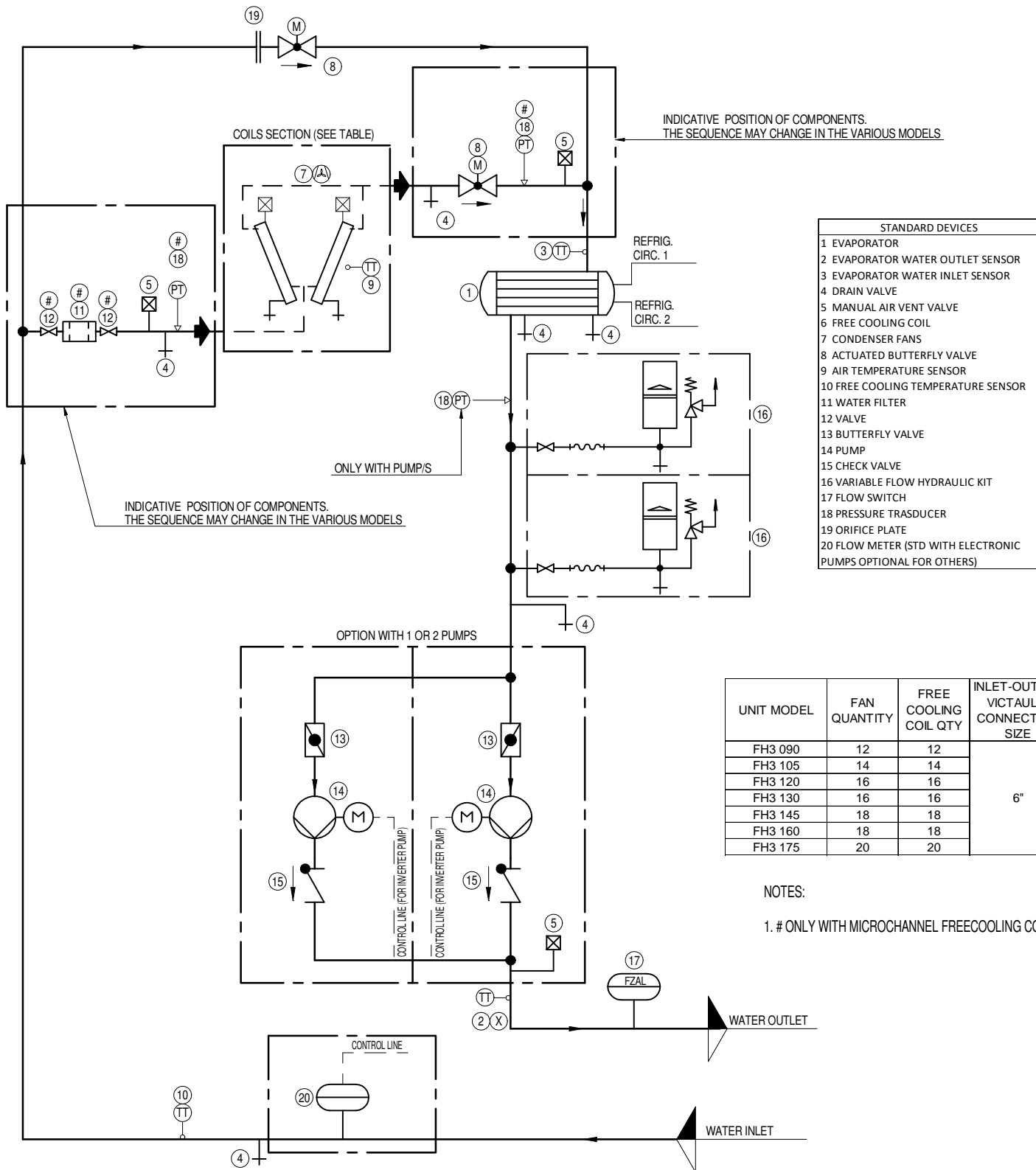

Connect with Vertiv on Social Media



<https://www.facebook.com/vertiv/>



<https://www.instagram.com/vertiv/>



<https://www.linkedin.com/company/vertiv/>



<https://www.x.com/Vertiv/>



Vertiv.com | Vertiv Headquarters, 505 N. Cleveland Ave., Westerville, OH 43082, USA

© 2024 Vertiv Group Corp. All rights reserved. Vertiv™ and the Vertiv logo are trademarks or registered trademarks of Vertiv Group Corp. All other names and logos referred to are trade names, trademarks or registered trademarks of their respective owners. While every precaution has been taken to ensure accuracy and completeness here, Vertiv Group Corp. assumes no responsibility, and disclaims all liability, for damages resulting from use of this information or for any errors or omissions.

SL-70790_RevA_12-24