

# KVM Switch - Rack Mount for Dell



## Quick Installation Guide

### Dell® ReadyRails™ Rack Mounting Configurations

The ReadyRails system can be installed using the 1U tool-less method or one of three possible 1U tooled methods (two-post flush mount, two-post center mount or four-post threaded mount).

#### 1U Tool-less Rail Install

The following steps describe the process for installing the ReadyRail system on a 1U rack using no tools.

##### 1. Positioning the rail between the vertical posts

With the ReadyRails flange ears facing outward, place one rail between the left and right vertical posts.

##### 2. Positioning the rear flange rail pegs

Align and seat the rear flange rail pegs in the rear vertical post flange. The top illustration shows how the pegs appear in both the square and unthreaded round holes.

##### 3. Positioning the front flange pegs

Align and seat the front flange pegs in the holes on the front side of the vertical post. Repeat this procedure for the second rail.

##### 4. Removing the rails

To remove each rail, pull on the latch release button on each flange ear and unseat each rail.

#### 1U Two-post Flush Mount

**NOTE:** For this configuration, the ReadyRails flange ear castings must be removed from the front side of each ReadyRails assembly.

##### 1. Removing the castings

Use a Torx™ driver to remove the two screws from each front flange ear (on the device side of the rail) and remove each casting.

**NOTE:** Retain the castings for future rack requirements. The rear castings do not need to be removed.

#### 1U Rail Install (Tool-less)

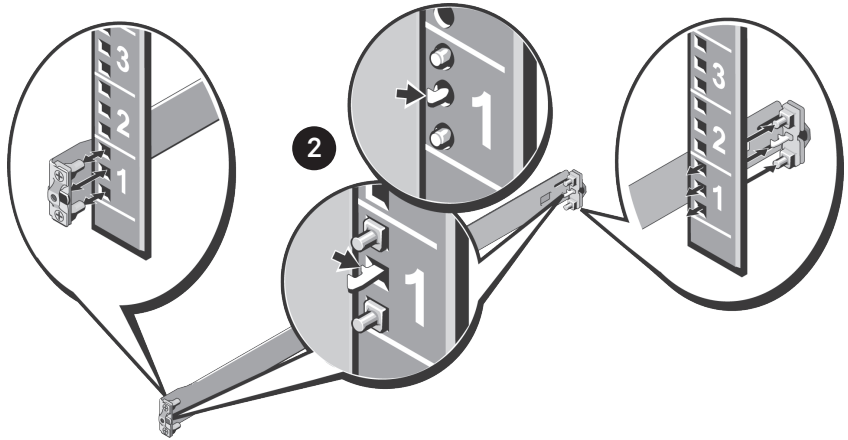

#### 1U Two-post Flush Mount (Tooled)

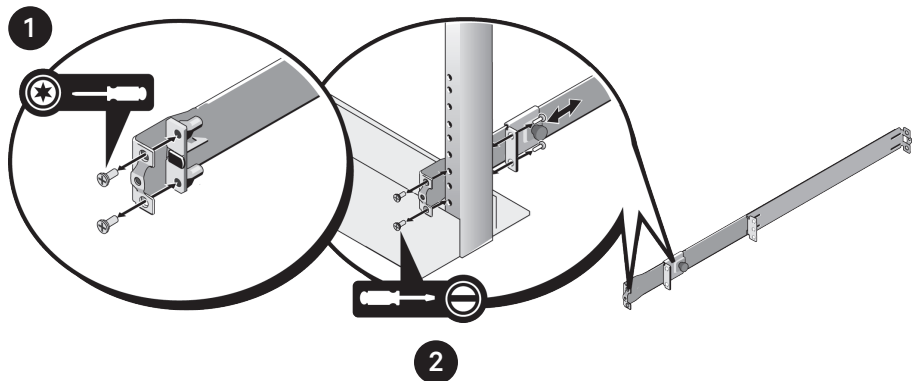

#### 1U Two-post Center Mount (Tooled)

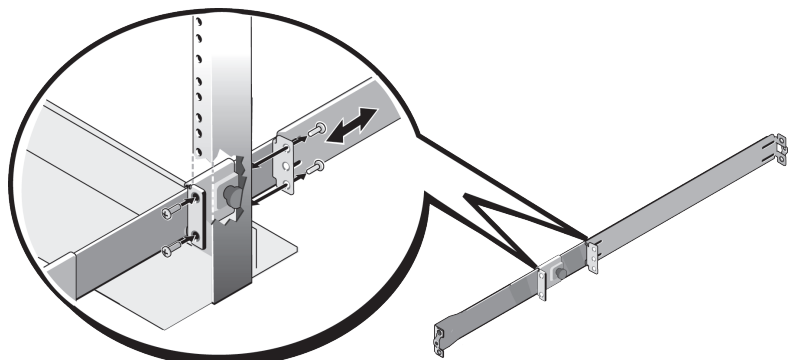

## 2. Attaching the rails

Attach one rail to the front post flange with two user-supplied screws. Slide the plunger bracket forward against the vertical post and secure the plunger bracket to the post flange with two user-supplied screws.

**NOTE:** Repeat this procedure for the second rail.

### 1U Two-post Center Mount

The following steps describe the process for installing the ReadyRail system on a 1U rack with a two-post center-mount.

#### 1. Securing the plunger bracket

Slide the plunger bracket rearward until it clicks into place and secure the bracket to the front post flange with two user-supplied screws.

#### 2. Securing the back bracket

Slide the back bracket towards the post and secure it to the post flange with two user-supplied screws.

**NOTE:** Repeat this procedure for the second rail.

### 1U Four-post Threaded Mount

**NOTE:** For this configuration, the ReadyRails flange ear castings must be removed from each end of the ReadyRails assemblies.

#### 1. Removing the castings

Use a Torx™ driver to remove the two screws from each flange ear and remove each casting. Retain the castings for future rack requirements.

#### 2. Attaching the rails

For each rail, attach the front and rear flanges to the post flanges with two user-supplied screws at each end.

### Switch Installation

The switch may be mounted in the 1U rear-rack, 1U front-rack and 0U configurations.

**NOTE:** Additional switch mount configurations include 1U two-post

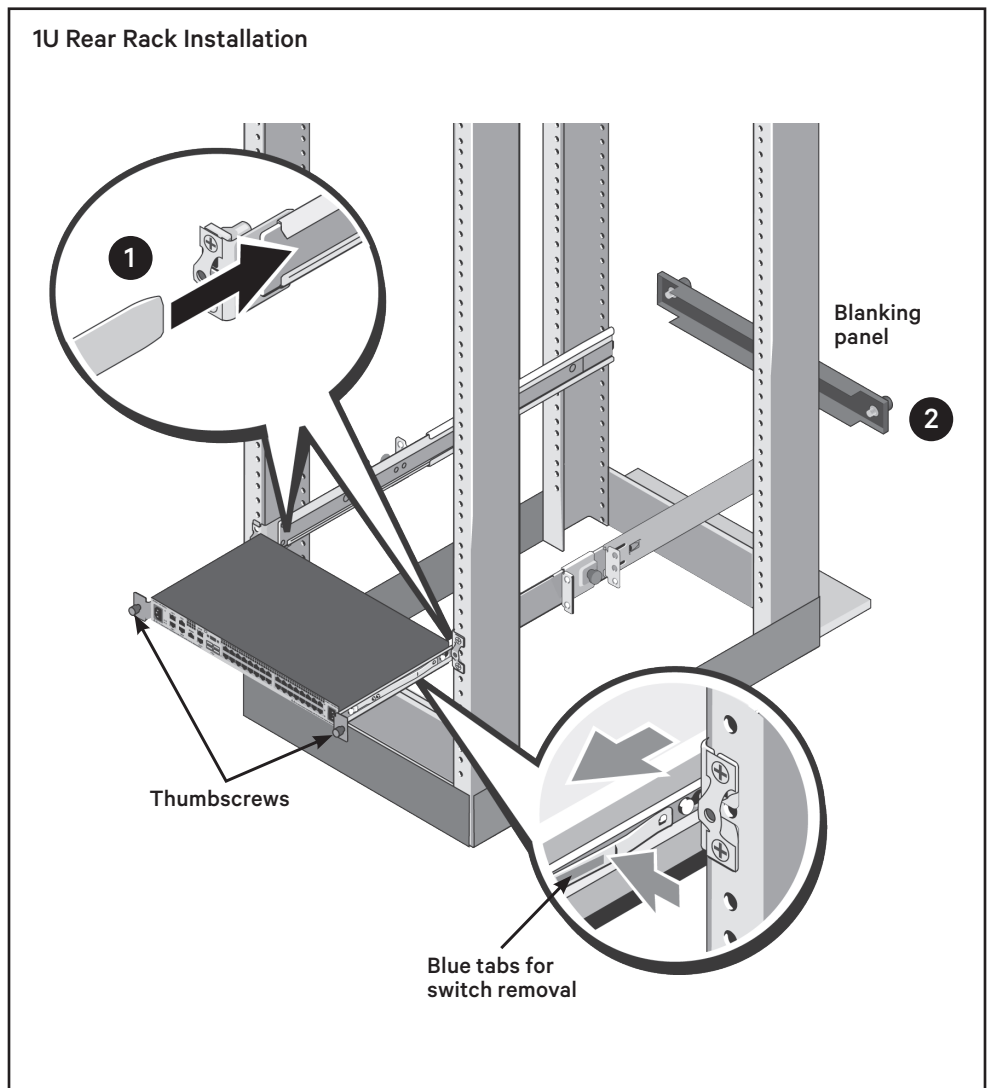
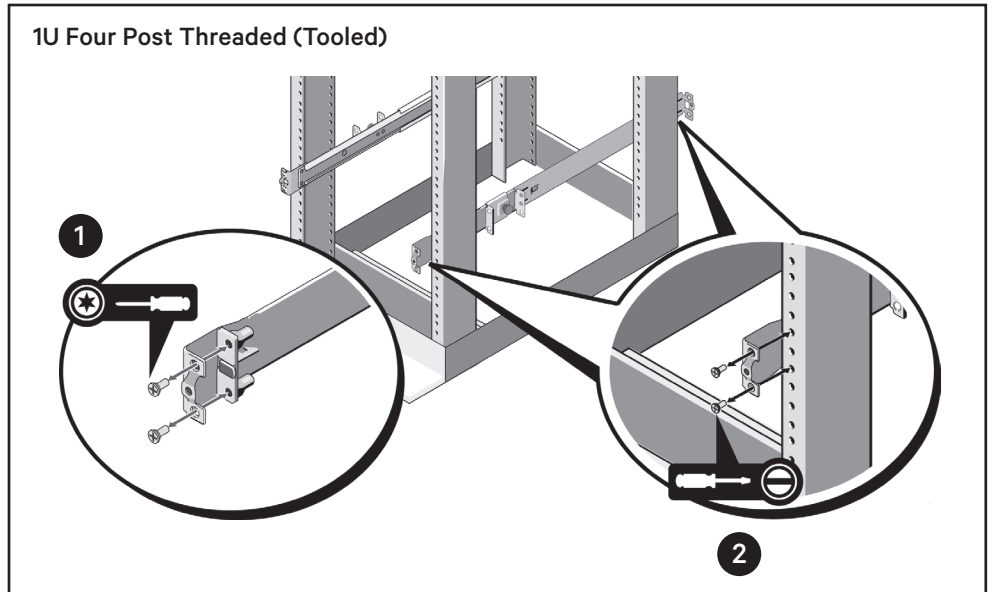

flush and 1U two-post center which are not shown in this quick installation guide.

### 1U Rear Rack Installation

#### 1. Positioning the switch in the rack

Insert the ends of the two rails that are attached to the switch into the ReadyRails assembly and push the switch into the rack.

#### 2. Securing the switch in the rack

Secure each switch rail with the thumbscrew. Assemble the optional blanking panel to the rails on the front side of the rack and tighten the thumbscrews.

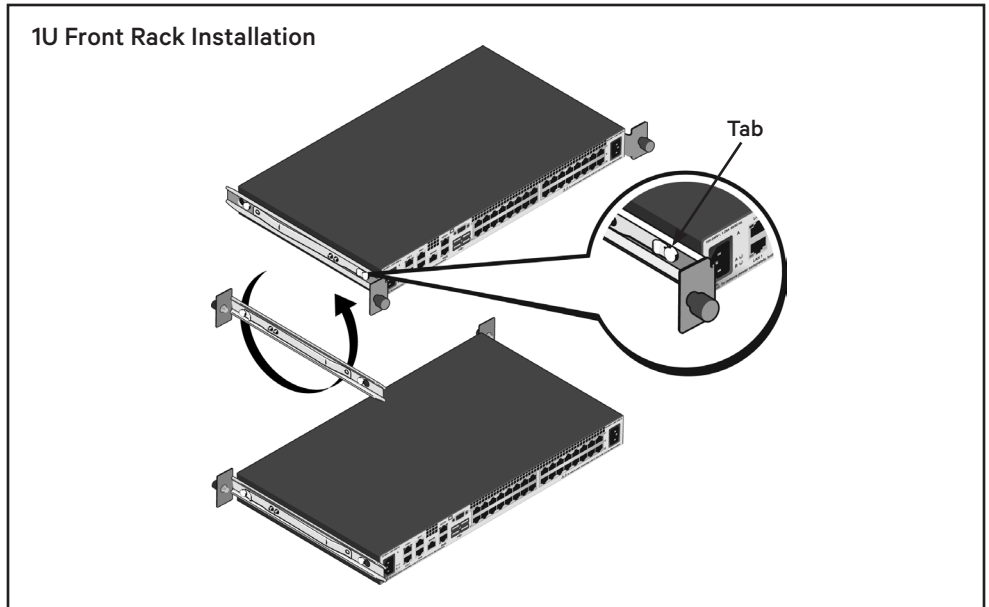

### 1U Rear Rack Removal

#### 1. Releasing the thumbscrews

Unscrew the thumbscrews and pull the switch assembly out of the rack until the travel stops are reached.

**NOTE:** The travel stop position is intended to provide the opportunity to reposition the rail grip; it is not intended for service.

#### 2. Removing the switch from the ReadyRails

Locate the blue tabs on the sides of the switch rails. Push the tabs inward and continue pulling the switch assembly until the switch rails are clear of the ReadyRails assemblies.

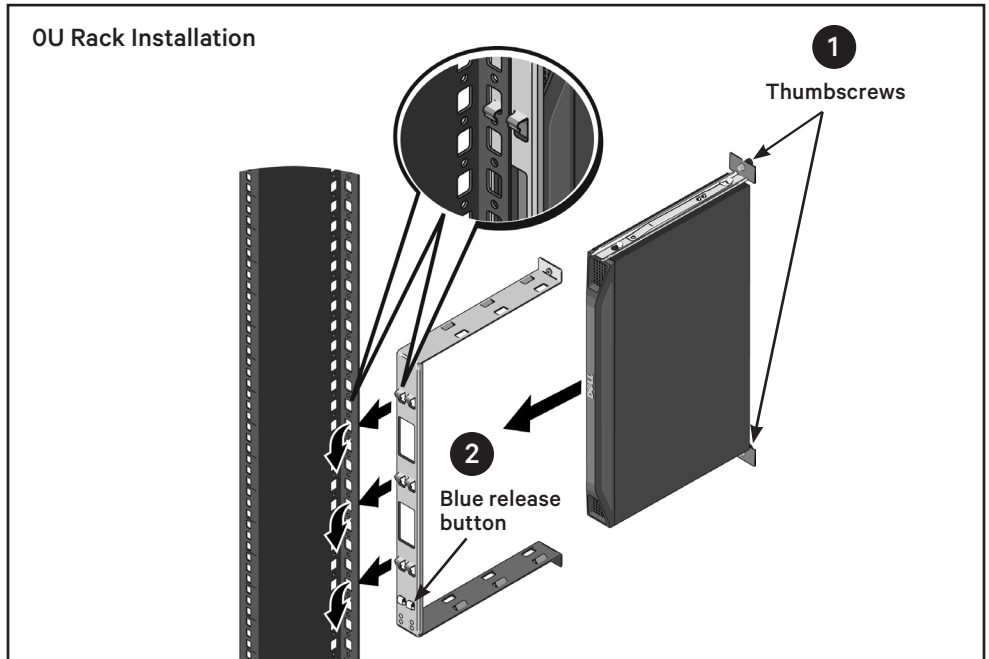

### 1U Front Rack Installation

On each switch rail, lift the tab under the front standoff and slide the rail forward as you lift the rail from the switch. Rotate each rail 180° and reassemble each rail to the switch.

**NOTE:** Refer to 1U Rear Rack Installation to insert and remove the switch assembly from the ReadyRails system.

**NOTE:** No blanking panel is required for this configuration.

### OU Rack Installation

#### 1. Positioning the bracket

Align and assemble the OU mounting bracket to the switch rails. Tighten the thumbscrews to secure the switch to the OU mounting bracket.

until the blue button pops out and locks the bracket into place.

#### OU Rack Removal

To remove the switch assembly, press the blue button to unseat the bracket and then lift the assembly from the posts.

#### 2. Securing the brackets

Insert the mounting bracket hooks into the rack holes and push down



**To contact Vertiv Technical Support: visit [www.Vertiv.com](http://www.Vertiv.com)**

© 2024 Vertiv Group Corp. All rights reserved. Vertiv™ and the Vertiv logo are trademarks or registered trademarks of Vertiv Group Corp. All other names and logos referred to are trade names, trademarks or registered trademarks of their respective owners. While every precaution has been taken to ensure accuracy and completeness here, Vertiv Group Corp. assumes no responsibility, and disclaims all liability, for damages resulting from use of this information or for any errors or omissions.

