

# KMMLED185 Console Tray Rack Mount



## Quick Installation Guide

Before installing the rack mount LCD console tray, stabilize the rack in a permanent location. Using the supplied 1U rack mount kit, rack mount your equipment starting at the bottom, then work to the top. Avoid uneven loading or overloading of racks.

**CAUTION:** Do not rack mount the equipment in a way that creates a hazardous condition due to uneven mechanical loading.

### 1. Installing the slide rails

#### Tool-less Install

Orient each slide rail so that its two flanged ends point outward from the center of the rack. Position the front flange over the holes of the desired U space on the rack post. Engage the two positioning pins and latch, inserting them into the post holes until the latch clicks in place. Repeat for the back slide rail flange.

#### Tooled Install

Using a Torx-head screwdriver and a flat-tipped screwdriver, remove the positioning pin/latch assembly from the front and back slide rail flanges. Position the slide rail in the desired U rack space and using the newly revealed flange holes, attach the slide rail flanges to the front and back rack posts using the two pairs of screws.

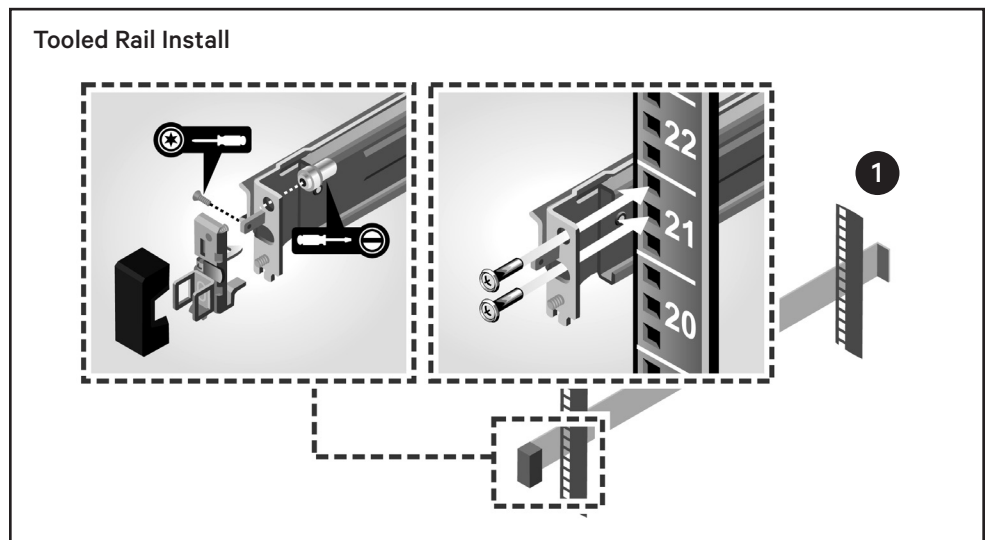
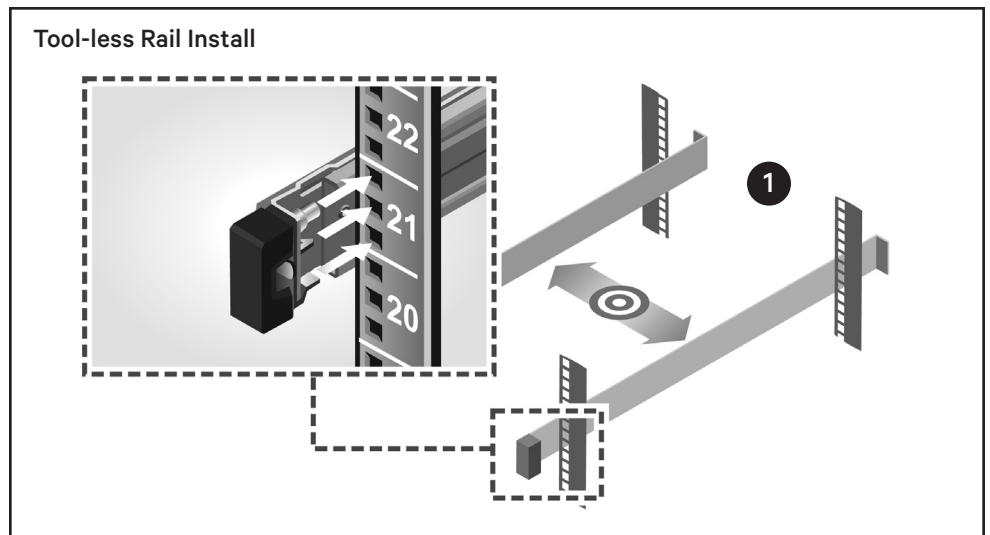

### 2. Installing the rack mount LCD console tray

**NOTE:** Ensure the system is properly supported until the chassis rail members are inserted into the slide rails on both sides.

Pull the slide rails out of the rack until they are fully extended. Confirm the ball-bearing races are at their forward-most position. Align and insert the ends of the inner rail members into the ends of the rails. Push the system inward until the inner rail members are fully inserted. Pull and push the LCD console tray in and out of the rack until it slides smoothly within the rack.

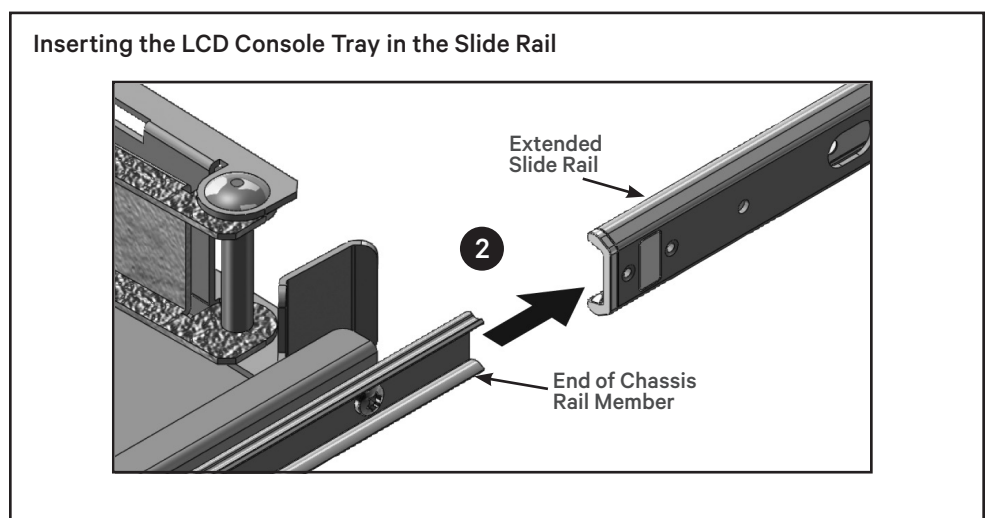

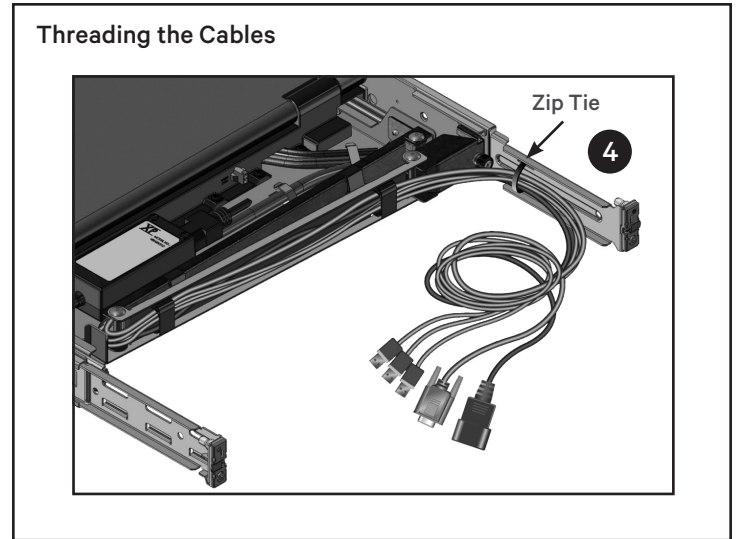
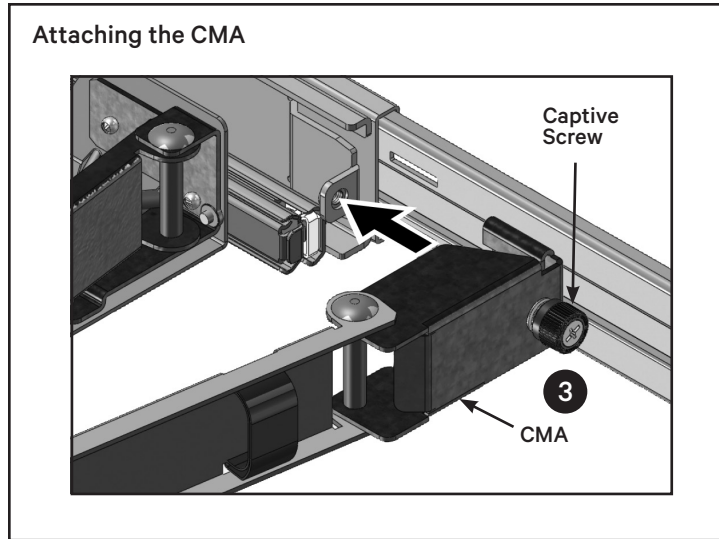

### 3. Attaching the Cable Management Arm (CMA)

From the back of the rack, cut the zip tie that secures the CMA to the back of the LCD console tray. Swing the free end of the CMA out to the bracket on the end of the left outer rail and attach the arm to the bracket with the captive screw on the end of the arm.

### 4. Threading the cables to the back of the rack

Gently thread the cables through the cable channel on the CMA, then secure the cables to the rear bracket, ensuring they aren't pulled too tight.

### Additional information

A translated version of this information is available in the Vertiv™ Rack Mount 18.5" LCD Console Tray for Dell Installer/ User Guide located at <https://www.vertiv.com/en-us/support/avocent-support-dell/>.

Ein übersetztes Installations-/ Benutzerhandbuch für das Vertiv™ 18,5-Zoll-LCD-Konsolen-Tray für Dell zur Befestigung im Rack finden Sie unter <https://www.vertiv.com/en-us/support/avocent-support-dell/>.

Hay una versión traducida de esta información en la guía de uso e instalación de la bandeja de consola LCD con montaje en rack de 18,5 pulg. Vertiv™ para Dell, disponible en <https://www.vertiv.com/en-us/support/avocent-support-dell/>.

Une version traduite de ces informations est disponible dans le Guide d'installation et d'utilisation du plateau de consola LCD 18,5" à montage en rack Vertiv™ pour Dell situé à l'adresse <https://www.vertiv.com/en-us/support/avocent-support-dell/>.

この情報の翻訳バージョンは、「Vertiv™ ラックマウント 18.5 インチ LCD コンソールトレイ (Dell 用) インストール/ユーザーガイド」を参照してください (<https://www.vertiv.com/en-us/support/avocent-support-dell/>)。

有关本信息的翻译版本，请参阅《适用于 Dell 的 Vertiv™ 机架式 18.5" LCD 控制台托盘安装人员/用户指南》，详见 <https://www.vertiv.com/en-us/support/avocent-support-dell/>。

有關本資訊的翻譯版本，請參閱《適用於 Dell 的 Vertiv™ 機架式 18.5" LCD 主控台托盤安裝/使用指南》，詳見 <https://www.vertiv.com/en-us/support/avocent-support-dell/>。

이 정보에 대한 번역본은 <https://www.vertiv.com/en-us/support/avocent-support-dell/>에 있는 Vertiv™ Rack Mount 18.5" LCD Dell 용 콘솔 트레이 설치자/사용자 설명서에 있습니다.

Перевод данной информации доступен в руководстве по установке ЖК-консоли для монтажа в стойку Vertiv™ Rack Mount 18.5" для устройств Dell по ссылке: <https://www.vertiv.com/en-us/support/avocent-support-dell/>.

Versi terjemahan informasi ini tersedia dalam Panduan Pengguna/Installer Baki Konsol LCD Rack Mount 18,5" untuk Dell Vertiv™ yang ada di <https://www.vertiv.com/en-us/support/avocent-support-dell/>.

To contact Vertiv Technical Support: visit [www.Vertiv.com](http://www.Vertiv.com)

© 2021 Vertiv Group Corp. All rights reserved. Vertiv™ and the Vertiv logo are trademarks or registered trademarks of Vertiv Group Corp. All other names and logos referred to are trade names, trademarks or registered trademarks of their respective owners. While every precaution has been taken to ensure accuracy and completeness here, Vertiv Group Corp. assumes no responsibility, and disclaims all liability, for damages resulting from use of this information or for any errors or omissions. Specifications, rebates and other promotional offers are subject to change at Vertiv's sole discretion upon notice.

